



State of West Virginia
 Department of Administration
 Purchasing Division
 2019 Washington Street East
 Post Office Box 50130
 Charleston, WV 25305-0130

Request for Quotation

RFQ NUMBER
GSD096452

PAGE
1

ADDRESS CORRESPONDENCE TO ATTENTION OF
**KRISTA FERRELL
 304-558-2596**

VENDOR

RFQ COPY
 TYPE NAME/ADDRESS HERE

**BROWN ELECTRIC CO. INC.
 1100 CHARLES AVENUE
 DUNBAR, WV 25004**

SHIP TO

DEPARTMENT OF ADMINISTRATION
 GENERAL SERVICES DIVISION
 BUILDING 11 CHILLER PLANT
 218 CALIFORNIA AVENUE
 CHARLESTON, WV
 25305 304-558-2317

DATE PRINTED	TERMS OF SALE	SHIP VIA	FOB	FREIGHT TERMS
06/25/2009				

BID OPENING DATE: **08/04/2009** BID OPENING TIME **01:30PM**

LINE	QUANTITY	UOP	CAT NO	ITEM NUMBER	UNIT PRICE	AMOUNT
0001	1	LS		968-42		M 112,800.00
<p>SECONDARY POWER FEED PROJECT, BLDG#11</p> <p>REQUEST FOR QUOTATION (RFQ)</p> <p>THE WEST VIRGINIA STATE PURCHASING DIVISION FOR THE AGENCY, THE WEST VIRGINIA DIVISION OF GENERAL SERVICES, IS SOLICITING BIDS TO PROVIDE THE AGENCY WITH ALL LABOR AND MATERIALS FOR ELECTRICAL HARDWARE REPLACEMENT AND UPGRADE FOR BUILDING # 11 (CHILLER PLANT) LOCATED ON THE WEST VIRGINIA STATE CAPITOL COMPLEX IN CHARLESTON, WEST VIRGINIA PER THE ATTACHED DRAWINGS AND SPECIFICATIONS.</p> <p>A MANDATORY PRE-BID MEETING WILL BE HELD ON THURSDAY, JULY 9, 2009 AT 1:00 PM IN THE SECOND FLOOR CONFERENCE ROOM IN BUILDING #11 LOCATED AT THE CORNER OF CALIFORNIA AVENUE AND PIEDMONT DRIVE IN CHARLESTON, WEST VIRGINIA. ALL PRIME/GENERAL CONTRACTORS WISHING BID ON THIS PROJECT MUST ATTEND THIS MEETING. SUBCONTRACTORS AND MATERIAL SUPPLIERS ARE WELCOME TO ATTEND; HOWEVER, ATTENDANCE IS NOT MANDATORY. ANY PRIME/GENERAL CONTRACTOR FAILING TO ATTEND THIS MEETING WILL BE DISQUALIFIED FROM BIDDING ON THIS PROJECT. NO ONE PERSON MAY REPRESENT MORE THAN ONE BIDDER.</p> <p>TECHNICAL QUESTIONS CONCERNING THIS PROJECT MUST BE</p>						

RECEIVED
 2009 AUG 11 PM 1:15
 WV PURCHASING DIVISION

SEE REVERSE SIDE FOR TERMS AND CONDITIONS			
SIGNATURE <i>[Signature]</i>	TELEPHONE 304-768-0407	DATE 8/4/2009	
TITLE COO	FEIN 55-028030	ADDRESS CHANGES TO BE NOTED ABOVE	

WHEN RESPONDING TO RFQ, INSERT NAME AND ADDRESS IN SPACE ABOVE LABELED 'VENDOR'

**GENERAL TERMS & CONDITIONS
REQUEST FOR QUOTATION (RFQ) AND REQUEST FOR PROPOSAL (RFP)**

1. Awards will be made in the best interest of the State of West Virginia.
2. The State may accept or reject in part, or in whole, any bid.
3. All quotations are governed by the *West Virginia Code* and the *Legislative Rules* of the Purchasing Division.
4. Prior to any award, the apparent successful vendor must be properly registered with the Purchasing Division and have paid the required \$125 fee
5. All services performed or goods delivered under State Purchase Order/Contracts are to be continued for the term of the Purchase Order/Contracts, contingent upon funds being appropriated by the Legislature or otherwise being made available. In the event funds are not appropriated or otherwise available for these services or goods, this Purchase Order/Contract becomes void and of no effect after June 30
6. Payment may only be made after the delivery and acceptance of goods or services.
7. Interest may be paid for late payment in accordance with the *West Virginia Code*
8. Vendor preference will be granted upon written request in accordance with the *West Virginia Code*
9. The State of West Virginia is exempt from federal and state taxes and will not pay or reimburse such taxes.
10. The Director of Purchasing may cancel any Purchase Order/Contract upon 30 days written notice to the seller.
11. The laws of the State of West Virginia and the *Legislative Rules* of the Purchasing Division shall govern all rights and duties under the Contract, including without limitation the validity of this Purchase Order/Contract
12. Any reference to automatic renewal is hereby deleted. The Contract may be renewed only upon mutual written agreement of the parties.
13. **BANKRUPTCY:** In the event the vendor/contractor files for bankruptcy protection, the State may deem this contract null and void, and terminate such contract without further order.
14. **HIPAA BUSINESS ASSOCIATE ADDENDUM:** The West Virginia State Government HIPAA Business Associate Addendum (BAA), approved by the Attorney General, and available online at the Purchasing Division's web site (<http://www.state.wv.us/admin/purchase/vrc/hipaa.htm>) is hereby made part of the agreement. Provided that, the Agency meets the definition of a Cover Entity (45 CFR §160.103) and will be disclosing Protected Health Information (45 CFR §160.103) to the vendor.
15. **WEST VIRGINIA ALCOHOL & DRUG-FREE WORKPLACE ACT:** If this Contract constitutes a public improvement construction contract as set forth in Article 1D, Chapter 21 of the West Virginia Code ("The West Virginia Alcohol and Drug-Free Workplace Act"), then the following language shall hereby become part of this Contract: "The contractor and its subcontractors shall implement and maintain a written drug-free workplace policy in compliance with the West Virginia Alcohol and Drug-Free Workplace Act, as set forth in Article 1D, Chapter 21 of the West Virginia Code. The contractor and its subcontractors shall provide a sworn statement in writing, under the penalties of perjury, that they maintain a valid drug-free work place policy in compliance with the West Virginia and Drug-Free Workplace Act. It is understood and agreed that this Contract shall be cancelled by the awarding authority if the Contractor: 1) Fails to implement its drug-free workplace policy; 2) Fails to provide information regarding implementation of the contractor's drug-free workplace policy at the request of the public authority; or 3) Provides to the public authority false information regarding the contractor's drug-free workplace policy."

INSTRUCTIONS TO BIDDERS

1. Use the quotation forms provided by the Purchasing Division.
2. **SPECIFICATIONS:** Items offered must be in compliance with the specifications. Any deviation from the specifications must be clearly indicated by the bidder. Alternates offered by the bidder as **EQUAL** to the specifications must be clearly defined. A bidder offering an alternate should attach complete specifications and literature to the bid. The Purchasing Division may waive minor deviations to specifications.
3. Complete all sections of the quotation form.
4. Unit prices shall prevail in case of discrepancy.
5. All quotations are considered F.O.B destination unless alternate shipping terms are clearly identified in the quotation
6. **BID SUBMISSION:** All quotations must be delivered by the bidder to the office listed below prior to the date and time of the bid opening. Failure of the bidder to deliver the quotations on time will result in bid disqualifications; Department of Administration, Purchasing Division, 2019 Washington Street East, P.O. Box 50130, Charleston, WV 25305-0130



State of West Virginia
 Department of Administration
 Purchasing Division
 2019 Washington Street East
 Post Office Box 50130
 Charleston, WV 25305-0130

Request for Quotation

RFQ NUMBER
 GSD096452

PAGE
 2

ADDRESS CORRESPONDENCE TO ATTENTION OF:
 KRISTA FERRELL
 304-558-2596

RFQ COPY
 TYPE NAME/ADDRESS HERE

PROPERTY

SHIP TO

DEPARTMENT OF ADMINISTRATION
 GENERAL SERVICES DIVISION
 BUILDING 11 CHILLER PLANT
 218 CALIFORNIA AVENUE
 CHARLESTON, WV
 25305 304-558-2317

DATE PRINTED	TERMS OF SALE	SHIP VIA	FOB	FREIGHT TERMS
06/25/2009				

BID OPENING DATE: 08/04/2009 BID OPENING TIME 01:30PM

LINE	QUANTITY	UOP	CAT NO	ITEM NUMBER	UNIT PRICE	AMOUNT
<p>SUBMITTED IN WRITING TO KRISTA FERRELL IN THE WEST VIRGINIA STATE PURCHASING DIVISION VIA FAX AT 304-558-4115 OR VIA EMAIL AT KRISTA.S.FERRELL@WV.GOV. DEADLINE FOR ALL TECHNICAL QUESTIONS IS THURSDAY JULY 16, 2009 AT THE CLOSE OF BUSINESS. ALL TECHNICAL QUESTIONS, RECEIVED, IF ANY, WILL BE ANSWERED BY ADDENDUM AFTER THE DEADLINE HAS LAPSED.</p> <p>QUESTIONS CONCERNING THE ACTUAL PROCESS BY WHICH A VENDOR MAY SUBMIT A BID TO THE STATE OF WEST VIRGINIA ARE NOT CONSIDERED TO BE TECHNICAL QUESTIONS AND MAY BE SUBMITTED AT ANY TIME PRIOR TO THE BID OPENING AND IN ANY FORMAT.</p> <p>EXHIBIT 5</p> <p>WEST VIRGINIA CODE 21-1D-5 PROVIDES THAT: ANY SOLICITATION FOR A PUBLIC IMPROVEMENT CONSTRUCTION CONTRACT REQUIRES EACH VENDOR THAT SUBMITS A BID FOR THE WORK TO SUBMIT AT THE SAME TIME AN AFFIDAVIT OF COMPLIANCE WITH THE BID. THE ENCLOSED DRUG-FREE WORKPLACE AFFIDAVIT MUST BE SIGNED AND SUBMITTED WITH THE BID AS EVIDENCE OF THE VENDOR'S COMPLIANCE WITH THE PROVISIONS OF ARTICLE 1D, CHAPTER 21 OF THE WEST VIRGINIA CODE. FAILURE TO SUBMIT THE SIGNED DRUG-FREE WORKPLACE AFFIDAVIT WITH THE BID SHALL RESULT IN DISQUALIFICATION OF SUCH BID.</p> <p>NOTICE TO PROCEED: THIS CONTRACT IS TO BE PERFORMED WITHIN 120 CALENDAR DAYS AFTER THE NOTICE TO PROCEED IS RECEIVED. UNLESS OTHERWISE SPECIFIED, THE FULLY EXECUTED PURCHASE ORDER WILL BE CONSIDERED NOTICE TO PROCEED.</p> <p>CANCELLATION: THE DIRECTOR OF PURCHASING RESERVES THE RIGHT TO CANCEL THIS CONTRACT IMMEDIATELY UPON WRITTEN NOTICE TO THE VENDOR IF THE MATERIALS OR WORKMANSHIP</p>						

SEE REVERSE SIDE FOR TERMS AND CONDITIONS

SIGNATURE	TELEPHONE	DATE
TITLE	FEIN	ADDRESS CHANGES TO BE NOTED ABOVE

WHEN RESPONDING TO RFQ, INSERT NAME AND ADDRESS IN SPACE ABOVE LABELED 'VENDOR'



State of West Virginia
 Department of Administration
 Purchasing Division
 2019 Washington Street East
 Post Office Box 50130
 Charleston, WV 25305-0130

Request for Quotation

RFQ NUMBER
 GSD096452

PAGE
 3

ADDRESS CORRESPONDENCE TO ATTENTION OF:
 KRISTA FERRELL
 304-558-2596

RFQ COPY
 TYPE NAME/ADDRESS HERE

VENDOR

SHIP TO

DEPARTMENT OF ADMINISTRATION
 GENERAL SERVICES DIVISION
 BUILDING 11 CHILLER PLANT
 218 CALIFORNIA AVENUE
 CHARLESTON, WV
 25305 304-558-2317

DATE PRINTED	TERMS OF SALE	SHIP VIA	F.O.B.	FREIGHT TERMS
06/25/2009				
BID OPENING DATE: 08/04/2009		BID OPENING TIME 01:30PM		

LINE	QUANTITY	UOP	CAT NO	ITEM NUMBER	UNIT PRICE	AMOUNT
<p>SUPPLIED ARE OF AN INFERIOR QUALITY OR DO NOT CONFORM WITH THE SPECIFICATIONS OF THE BID AND CONTRACT HERE IN.</p> <p>WAGE RATES: THE CONTRACTOR OR SUBCONTRACTOR SHALL PAY THE HIGHER OF THE U.S. DEPARTMENT OF LABOR MINIMUM WAG RATES AS ESTABLISHED FOR KANAWHA COUNTY, PURSUANT TO WEST VIRGINIA CODE 21-5A, ET, SEQ. (PREVAILING WAGE RATES APPLY TO THIS PROJECT)</p> <p>ARBITRATION: ANY REFERENCES MADE TO ARBITRATION OR INTEREST FOR PAYMENTS DUE (EXCEPT FOR ANY INTEREST REQUIRED BY STATE LAW) CONTAINED IN THIS CONTRACT OR IN ANY AMERICAN INSTITUTE OF ARCHITECTS DOCUMENTS PERTAINING TO THIS CONTRACT ARE HEREBY DELETED.</p> <p>WORKERS' COMPENSATION: VENDOR IS REQUIRED TO PROVIDE A CERTIFICATE FROM WORKERS' COMPENSATION, IF SUCCESSFUL, FOR THE LIFE OF THE CONTRACT.</p> <p>ALL OF THE ITEMS CHECKED BELOW WILL BE A REQUIREMENT OF THIS CONTRACT:</p> <p>(XX) INSURANCE: SUCCESSFUL VENDOR SHALL FURNISH PROOF OF COMMERCIAL GENERAL LIABILITY INSURANCE PRIOR TO ISSUANCE OF CONTRACT. UNLESS OTHERWISE SPECIFIED IN THE BID DOCUMENTS, THE MINIMUM AMOUNT OF INSURANCE COVERAGE REQUIRED IS \$1,000,000.00.</p> <p>() BUILDERS RISK INSURANCE: SUCCESSFUL VENDOR SHALL FURNISH PROOF OF BUILDERS RISK - ALL RISK INSURANCE IN AN AMOUNT EQUAL TO 100% OF THE AMOUNT OF THE CONTRACT.</p> <p>(XX) BONDS: FIVE PERCENT (5%) OF THE TOTAL AMOUNT OF THE BID PAYABLE TO THE STATE OF WEST VIRGINIA, SHALL BE SUBMITTED WITH EACH BID AS A BID BOND. THE SUCCESSFUL</p>						

SEE REVERSE SIDE FOR TERMS AND CONDITIONS

SIGNATURE	TELEPHONE	DATE
TITLE	FEIN	ADDRESS CHANGES TO BE NOTED ABOVE

WHEN RESPONDING TO RFQ, INSERT NAME AND ADDRESS IN SPACE ABOVE LABELED 'VENDOR'



State of West Virginia
 Department of Administration
 Purchasing Division
 2019 Washington Street East
 Post Office Box 50130
 Charleston, WV 25305-0130

Request for Quotation

RFQ NUMBER
 GSD096452

PAGE
 4

ADDRESS CORRESPONDENCE TO ATTENTION OF
 KRISTA FERRELL
 304-558-2596

RFQ COPY
 TYPE NAME/ADDRESS HERE

V
E
N
D
O
R

S
H
I
P
T
O

DEPARTMENT OF ADMINISTRATION
 GENERAL SERVICES DIVISION
 BUILDING 11 CHILLER PLANT
 218 CALIFORNIA AVENUE
 CHARLESTON, WV
 25305 304-558-2317

DATE PRINTED	TERMS OF SALE	SHIP VIA	FOB	FREIGHT TERMS
06/25/2009				

BID OPENING DATE: 08/04/2009 BID OPENING TIME 01:30PM

LINE	QUANTITY	UOP	CAT NO	ITEM NUMBER	UNIT PRICE	AMOUNT
<p>BIDDER SHALL ALSO FURNISH A PERFORMANCE BOND AND LABOR/MATERIAL BOND FOR 100% OF THE AMOUNT OF THE CONTRACT. BONDS MAY BE PROVIDED IN THE FORM OF A CERTIFIED CHECK, IRREVOCABLE LETTER OF CREDIT, OR BOND FURNISHED BY A SOLVENT SURETY COMPANY AUTHORIZED TO DO BUSINESS IN THE STATE OF WEST VIRGINIA. A LETTER OF CREDIT SUBMITTED IN LIEU OF A BOND WILL ONLY BE ALLOWED FOR PROJECTS UNDER \$100,000. PERSONAL OR BUSINESS CHECKS ARE NOT ACCEPCTABLE IN LIEU OF THE 5% BID BOND, PERFORMANCE BOND, OR LABOR AND MATERIAL BOND.</p> <p>() MAINTENANCE BOND: A TWO (2) YEAR MAINTENANCE BON COVERING THE ROOFING SYSTEM WILL BE A REQUIREMENT OF THE SUCCESSFUL VENDOR.</p> <p>REV. 11/00</p> <p>EXHIBIT 7</p> <p>DOMESTIC ALUMINUM, GLASS & STEEL IN PUBLIC WORKS PROJECTS</p> <p>IN ACCORDANCE WITH WEST VIRGINIA CODE 5-19-1 ET., SEQ., EVERY CONTRACT FOR CONSTRUCTION, RECONSTRUCTION, ALTERATION, REPAIR, IMPROVEMENT OR MAINTENANCE OF PUBLIC WORKS, WHERE THE COST IS MORE THAN \$50,000 AND, IN THE CASE OF STEEL ONLY, WHERE THE COST OF STEEL IS MORE THAN \$50,000 OR WHERE MORE THAN 10,000 POUNDS OF STEEL ARE REQUIRED, THE STATE WILL ACCEPT ONLY ALUMINU GLASS, OR STEEL PRODUCTS PRODUCED IN THE UNITED STATES. IN ADDITION, ITEMS OF MACHINERY OR EQUIPMENT PURCHASED FOR USE AT THE SITE OF PUBLIC WORKS SHALL BE MADE OF DOMESTIC ALUMINUM, GLASS OR STEEL, UNLESS THE COST OF THE PRODUCT IS LESS THAN \$50,000 OR LESS THAN 10,000 POUNDS OF STEEL ARE USED IN PUBLIC WORKS PROJECTS.</p>						

SEE REVERSE SIDE FOR TERMS AND CONDITIONS

SIGNATURE	TELEPHONE	DATE
-----------	-----------	------

TITLE	FEIN	ADDRESS CHANGES TO BE NOTED ABOVE
-------	------	-----------------------------------

WHEN RESPONDING TO RFQ, INSERT NAME AND ADDRESS IN SPACE ABOVE LABELED 'VENDOR'



State of West Virginia
 Department of Administration
 Purchasing Division
 2019 Washington Street East
 Post Office Box 50130
 Charleston, WV 25305-0130

Request for Quotation

RFQ NUMBER
 GSD096452

PAGE
 5

ADDRESS CORRESPONDENCE TO ATTENTION OF
 KRISTA FERRELL
 304-558-2596

RFQ COPY
 TYPE NAME/ADDRESS HERE

VENDOR

DEPARTMENT

DEPARTMENT OF ADMINISTRATION
 GENERAL SERVICES DIVISION
 BUILDING 11 CHILLER PLANT
 218 CALIFORNIA AVENUE
 CHARLESTON, WV
 25305 304-558-2317

DATE PRINTED 06/25/2009	TERMS OF SALE	SHIP VIA	FOB	FREIGHT TERMS
----------------------------	---------------	----------	-----	---------------

BID OPENING DATE: 08/04/2009 BID OPENING TIME 01:30PM

LINE	QUANTITY	UOP	CAT NO	ITEM NUMBER	UNIT PRICE	AMOUNT
<p>FOREIGN MADE ALUMINUM, GLASS OR STEEL PRODUCTS MAY BE ACCEPTED ONLY IF THE COST OF DOMESTIC PRODUCTS IS FOUND TO BE UNREASONABLE. SUCH COST IS UNREASONABLE IF IT IS 20% OR MORE HIGHER THAN THE BID PRICE FOR FOREIGN MADE PRODUCTS. IF THE DOMESTIC ALUMINUM, GLASS OR STEEL PRODUCTS TO BE SUPPLIED OR PRODUCED IN A "SUBSTANTIAL LABOR SURPLUS AREA", AS DEFINED BY THE UNITED STATES DEPARTMENT OF LABOR, FOREIGN PRODUCTS MAY BE SUPPLIED ONLY IF DOMESTIC PRODUCTS ARE 30% OR MORE HIGHER IN PRICE THAN THE FOREIGN MADE PRODUCTS.</p> <p>IF, PRIOR TO THE AWARD OF A CONTRACT UNDER THE ABOVE PROVISIONS, THE SPENDING OFFICER OF THE SPENDING UNIT DETERMINES THAT THERE EXISTS A BID FOR LIKE FOREIGN ALUMINUM, GLASS OR STEEL THAT IS REASONABLE AND LOWER THAN THE LOWEST BID DOMESTIC PRODUCTS, THE SPENDING OFFICE MAY REQUEST, IN WRITING, A REEVALUATION AND REDUCTION IN THE LOWEST BID FOR SUCH DOMESTIC PRODUCTS. ALL VENDORS MUST INDICATE IN THEIR BID IF THEY ARE SUPPLYING FOREIGN ALUMINUM, GLASS OR STEEL.</p> <p>REV. 3/88</p> <p>EXHIBIT 9</p> <p>NOTICE FOR ISSUANCE & ACKNOWLEDGEMENT OF CONSTRUCTION PROJECT ADDENDA</p> <p>THE ARCHITECT/ENGINEER AND/OR AGENCY SHALL BE REQUIRED TO ABIDE BY THE FOLLOWING SCHEDULE IN ISSUING CONSTRUCTION PROJECT ADDENDA FOR STATE AGENCIES:</p> <p>(1) THE ARCHITECT/ENGINEER SHALL PREPARE THE ADDENDUM AND A LIST OF ALL PARTIES THAT HAVE PROCURED DRAWINGS</p>						

SEE REVERSE SIDE FOR TERMS AND CONDITIONS

SIGNATURE	TELEPHONE	DATE
-----------	-----------	------

TITLE	FEIN	ADDRESS CHANGES TO BE NOTED ABOVE
-------	------	-----------------------------------

WHEN RESPONDING TO RFQ, INSERT NAME AND ADDRESS IN SPACE ABOVE LABELED 'VENDOR'



State of West Virginia
 Department of Administration
 Purchasing Division
 2019 Washington Street East
 Post Office Box 50130
 Charleston, WV 25305-0130

Request for Quotation

RFQ NUMBER
 GSD096452

PAGE
 6

ADDRESS CORRESPONDENCE TO ATTENTION OF
 KRISTA FERRELL
 304-558-2596

VENDOR

RFQ COPY
 TYPE NAME/ADDRESS HERE

SHIP TO

DEPARTMENT OF ADMINISTRATION
 GENERAL SERVICES DIVISION
 BUILDING 11 CHILLER PLANT
 218 CALIFORNIA AVENUE
 CHARLESTON, WV
 25305 304-558-2317

DATE PRINTED	TERMS OF SALE	SHIP VIA	F.O.B.	FREIGHT TERMS
06/25/2009				

BID OPENING DATE: 08/04/2009 BID OPENING TIME 01:30PM

LINE	QUANTITY	UOP	CAT NO	ITEM NUMBER	UNIT PRICE	AMOUNT
<p>AND SPECIFICATIONS FOR THE PROJECT. THE ADDENDUM AND LIST SHALL BE FORWARDED TO THE BUYER IN THE STATE PURCHASING DIVISION. THE ARCHITECT/ENGINEER SHALL ALSO SEND A COPY OF THE ADDENDUM TO THE STATE AGENCY FOR WHICH THE CONTRACT IS ISSUED.</p> <p>(2) THE BUYER SHALL SEND THE ADDENDUM TO ALL INTERESTED PARTIES AND, IF NECESSARY, EXTEND THE BID OPENING DATE. ANY ADDENDUM SHOULD BE RECEIVED BY THE BUYER WITHIN FOURTEEN (14) DAYS PRIOR TO THE BID OPENING DATE.</p> <p>(3) ALL ADDENDA SHOULD BE FORMALLY ACKNOWLEDGED BY ALL BIDDERS AND SUBMITTED TO THE STATE PURCHASING DIVISION. THE SAME RULES AND REGULATIONS THAT APPLY TO THE ORIGINAL BIDDING DOCUMENT SHALL ALSO APPLY TO AN ADDENDUM DOCUMENT. THE ONLY EXCEPTION MAY BE FOR AN ADDENDUM THAT IS ISSUED FOR THE SOLE PURPOSE OF CHANGING A BID OPENING TIME AND/OR DATE.</p> <p>REV. 11/96</p> <p>EXHIBIT 10</p> <p>ADDENDUM ACKNOWLEDGEMENT</p> <p>I HEREBY ACKNOWLEDGE RECEIPT OF THE FOLLOWING CHECKED ADDENDUM(S) AND HAVE MADE THE NECESSARY REVISIONS TO MY PROPOSAL, PLANS AND/OR SPECIFICATION, ETC.</p> <p>ADDENDUM NOS : NO. 1 .. 8/14/2009</p>						

SEE REVERSE SIDE FOR TERMS AND CONDITIONS

SIGNATURE	TELEPHONE	DATE
TITLE	FEIN	ADDRESS CHANGES TO BE NOTED ABOVE

WHEN RESPONDING TO RFQ, INSERT NAME AND ADDRESS IN SPACE ABOVE LABELED 'VENDOR'



State of West Virginia
 Department of Administration
 Purchasing Division
 2019 Washington Street East
 Post Office Box 50130
 Charleston, WV 25305-0130

Request for Quotation

REQ NUMBER
 GSD096452

PAGE
 7

ADDRESS CORRESPONDENCE TO ATTENTION OF
 KRISTA FERRELL
 304-558-2596

VENDOR

RFQ COPY
 TYPE NAME/ADDRESS HERE

SHIP TO

DEPARTMENT OF ADMINISTRATION
 GENERAL SERVICES DIVISION
 BUILDING 11 CHILLER PLANT
 218 CALIFORNIA AVENUE
 CHARLESTON, WV
 25305 304-558-2317

DATE PRINTED	TERMS OF SALE	SHIP VIA	FOB	FREIGHT TERMS
06/25/2009				

BID OPENING DATE: 08/04/2009 BID OPENING TIME 01:30PM

LINE	QUANTITY	UOP	CAT NO	ITEM NUMBER	UNIT PRICE	AMOUNT
NO. 2						
NO. 3						
NO. 4						
NO. 5						

I UNDERSTAND THAT FAILURE TO CONFIRM THE RECEIPT OF THE ADDENDUM(S) MAY BE CAUSE FOR REJECTION OF THE BIDS.

VENDOR MUST CLEARLY UNDERSTAND THAT ANY VERBAL REPRESENTATION MADE OR ASSUMED TO BE MADE DURING ANY ORAL DISCUSSION HELD BETWEEN VENDOR'S REPRESENTATIVES AND ANY STATE PERSONNEL IS NOT BINDING. ONLY THE INFORMATION ISSUED IN WRITING AND ADDED TO THE SPECIFICATIONS BY AN OFFICIAL ADDENDUM IS BINDING.

[Signature] SIGNATURE
 BROWN RETIRE CO, INC COMPANY
 8/4/2009 DATE

REV. 11/96

CONTRACTORS LICENSE

WEST VIRGINIA STATE CODE 21-11-2 REQUIRES THAT ALL PERSONS DESIRING TO PERFORM CONTRACTING WORK IN THIS STATE MUST BE LICENSED. THE WEST VIRGINIA CONTRACTORS LICENSING BOARD IS EMPOWERED TO ISSUE THE CONTRACTORS LICENSE. APPLICATIONS FOR A CONTRACTORS LICENSE MAY BE MADE BY CONTACTING THE WEST VIRGINIA DIVISION OF LABOR

SEE REVERSE SIDE FOR TERMS AND CONDITIONS

SIGNATURE	TELEPHONE	DATE
TITLE	FEIN	ADDRESS CHANGES TO BE NOTED ABOVE

WHEN RESPONDING TO RFQ, INSERT NAME AND ADDRESS IN SPACE ABOVE LABELED 'VENDOR'



State of West Virginia
 Department of Administration
 Purchasing Division
 2019 Washington Street East
 Post Office Box 50130
 Charleston, WV 25305-0130

Request for Quotation

RFQ NUMBER
 GSD096452

PAGE
 8

ADDRESS CORRESPONDENCE TO ATTENTION OF
 KRISTA FERRELL
 304-558-2596

RFQ COPY
 TYPE NAME/ADDRESS HERE

VENDOR

SUPPLIER

DEPARTMENT OF ADMINISTRATION
 GENERAL SERVICES DIVISION
 BUILDING 11 CHILLER PLANT
 218 CALIFORNIA AVENUE
 CHARLESTON, WV
 25305 304-558-2317

DATE PRINTED	TERMS OF SALE	SHIP VIA	FOB	FREIGHT TERMS
06/25/2009				

BID OPENING DATE: 08/04/2009 BID OPENING TIME 01:30PM

LINE	QUANTITY	UOP	CAT NO	ITEM NUMBER	UNIT PRICE	AMOUNT
<p>CAPITOL COMPLEX, BUILDING 3, ROOM 319, CHARLESTON, WV 25305. TELEPHONE: (304) 558-7890.</p> <p>WEST VIRGINIA STATE CODE 21-11-11 REQUIRES ANY PROSPECTIVE BIDDER TO INCLUDE THE CONTRACTORS LICENSE NUMBER ON THEIR BID.</p> <p>BIDDER TO COMPLETE:</p> <p>CONTRACTORS NAME: <i>BROWN ELECTRIC CO., INC.</i></p> <p>CONTRACTORS LICENSE NO.: <i>WV003517</i></p> <p>THE SUCCESSFUL BIDDER WILL BE REQUIRED TO FURNISH A COPY OF THEIR CONTRACTORS LICENSE PRIOR TO ISSUANCE OF A PURCHASE ORDER/CONTRACT</p> <p>APPLICABLE LAW</p> <p>THE WEST VIRGINIA STATE CODE, PURCHASING DIVISION RULES AND REGULATIONS, AND THE INFORMATION PROVIDED IN THE "REQUEST FOR QUOTATION" ISSUED BY THE PURCHASING DIVISION IS THE SOLE AUTHORITY GOVERNING THIS PROCUREMENT.</p> <p>ANY INFORMATION PROVIDED IN SPECIFICATION MANUALS, OR ANY OTHER SOURCE, VERBAL OR WRITTEN, WHICH CONTRADICTS OR ALTERS THE INFORMATION PROVIDED FROM THE SOURCES AS DESCRIBED IN THE ABOVE PARAGRAPH IS VOID AND OF NO EFFECT.</p> <p>BANKRUPTCY: IN THE EVENT THE VENDOR/CONTRACTOR FILES FOR BANKRUPTCY PROTECTION, THE STATE MAY DEEM THE CONTRACT NULL AND VOID AND TERMINATE SUCH CONTRACT WITHOUT FURTHER ORDER.</p>						

SEE REVERSE SIDE FOR TERMS AND CONDITIONS

SIGNATURE _____ TELEPHONE _____ DATE _____

TITLE _____ FEIN _____ ADDRESS CHANGES TO BE NOTED ABOVE

WHEN RESPONDING TO RFQ, INSERT NAME AND ADDRESS IN SPACE ABOVE LABELED 'VENDOR'



State of West Virginia
 Department of Administration
 Purchasing Division
 2019 Washington Street East
 Post Office Box 50130
 Charleston, WV 25305-0130

Request for Quotation

RFQ NUMBER
GSD096452

PAGE
9

ADDRESS CORRESPONDENCE TO ATTENTION OF
KRISTA FERRELL
304-558-2596

VENDOR

RFQ COPY
 TYPE NAME/ADDRESS HERE

SHIP TO

DEPARTMENT OF ADMINISTRATION
 GENERAL SERVICES DIVISION
 BUILDING 11 CHILLER PLANT
 218 CALIFORNIA AVENUE
 CHARLESTON, WV
 25305 304-558-2317

DATE PRINTED	TERMS OF SALE	SHIP VIA	F.O.B.	FREIGHT TERMS
06/25/2009				

BID OPENING DATE: **08/04/2009** BID OPENING TIME **01:30PM**

LINE	QUANTITY	UOP	CAT NO	ITEM NUMBER	UNIT PRICE	AMOUNT
REV. 5/2009						
NOTICE						
A SIGNED BID MUST BE SUBMITTED TO:						
DEPARTMENT OF ADMINISTRATION PURCHASING DIVISION BUILDING 15 2019 WASHINGTON STREET, EAST CHARLESTON, WV 25305-0130						
THE BID SHOULD CONTAIN THIS INFORMATION ON THE FACE OF THE ENVELOPE OR THE BID MAY NOT BE CONSIDERED:						
SEALED BID						
BUYER: KRISTA FERRELL-FILE 21						
REQ. NO.: GSD096452						
BID OPENING DATE: 08/04/2009						
BID OPENING TIME: 1:30 PM						
PLEASE PROVIDE A FAX NUMBER IN CASE IT IS NECESSARY TO CONTACT YOU REGARDING YOUR BID:						
----- 304-768-1046 -----						
PLEASE PRINT OR TYPE NAME OF PERSON TO CONTACT CONCERNING THIS QUOTE:						
----- BENJAMIN MATTHEW -----						

SEE REVERSE SIDE FOR TERMS AND CONDITIONS

SIGNATURE	TELEPHONE	DATE
TITLE	FAX	ADDRESS CHANGES TO BE NOTED ABOVE

WHEN RESPONDING TO RFQ, INSERT NAME AND ADDRESS IN SPACE ABOVE LABELED 'VENDOR'

RFQ#GSD096452

GENERAL SERVICES DIVISION

Chiller Plant Secondary Power Feed Project

BID FORM

Bidder's Company Name: BROWN ELECTRIC CO., INC.Bidder's Address: 1100 CHARLES AVENUE
DUNBAR, WV 25064Remittance Address: _____
(if different)Phone Number: 304-768-0407Fax Number: 304-768-0426Email Address: B.MITCHELL@BROWNELC.COMWV Contractor's License Number: WV 003517

We, the undersigned, having examined the site and being familiar with the local conditions affecting the cost of the work and also being familiar with the general conditions to bidders, drawings, and specifications, hereby propose to furnish all materials, equipment, and labor to complete all work in a workmanlike manner, as described in the Bidding Documents.

TOTAL CONTRACT BID

ONE HUNDRED TWELVE THOUSAND EIGHT HUNDRED DOLLARS(\$ 112,800.00)

(Total to be written in words and numbers.)

PRICE UTILIZES CUTLER HAMMER GEAR THAT MEETS SPECIFICATION (SEE ATTACHED)

SHOULD GENERAL ELECTRIC GEAR BE REQUIRED PRICE INCREASES ^{\$}50,900.00

\$163,700.00

The Bidder understands that to the extent allowed by the West Virginia Code, the OWNER reserves the right to waive any informality or irregularity in any Bid, or Bids, and to reject any or all Bids in whole or in part; to reject a bid not accompanied by the required bid security or by other data required by the Bidding Documents; to reject any conditions of the bid by the Bidder that is in any way inconsistent with the requirements, terms, and conditions of the Bidding Documents; or to reject a bid that is in any way incomplete or irregular

The Bidder, if successful and awarded the contract, agrees that all work is to be complete within one hundred twenty (120) consecutive calendar days following issuance of the OWNER'S written notice to proceed. For each calendar day of delay in achieving completion, the Contractor shall be liable for, and shall pay the OWNER liquidated damages in the amount of \$250 00 per day

Any work performed or any materials contracted for prior to the receipt of the OWNER'S written notice to proceed shall be at the Bidder's risk.

Progress payments during the life of the contract will be permissible, with monthly invoices submitted in arrears for work performed from the first to the final day of the preceding month, with a 5% retainage being deducted. When the WORK under contract has been complete and its acceptance is recommended by the OWNER, the retainage shall be released and paid to the CONTRACTOR.

ADDENDUM ACKNOWLEDGEMENT

I hereby acknowledge receipt of the following checked addendum and have made the necessary revisions to my proposal.

Addendum No	Date
#1	7/14/2009
#2	8/3/2009

I understand that failure to confirm the receipt of the Addendum is cause for rejection of bids

8/4/2009

 Signature Date

RESPECTFULLY SUBMITTED:

DATE: 8/4/2009

WV VENDOR NUMBER: 823 000 941

BY: 

 (Signature in ink)

TITLE: CHIEF OPERATING OFFICER

FIRM NAME: BROWN ELECTRIC CO., INC.

ADDRESS: 1100 CHARLES AVENUE DUNBAR, WV 25004

References:

Reference Name: TOMMY YOUNG
 Position: PROJECT ENGINEER
 Address: 1116 SMITH STREET, SUITE 406, CHARLSTON, WV 25301
 Telephone Number: 304-233-0140
 Project Name: CHAPMANVILLE HIGH SCHOOL
 Project Description: NEW SCHOOL CONSTRUCTION

Reference Name: MIKE ARONWATNY
 Position: ARCHITECT
 Address: 222 LEE STREET, CHARLSTON, WV 25302-2225
 Telephone Number: 304-342-0159
 Project Name: WV SOUTHERN REGIONAL STADIUM
 Project Description: FIRE ALARM RECOMMENDATION

Reference Name: MARTIN STEWART
 Position: OWNER'S REPRESENTATIVE
 Address: 208 26TH STREET, W CHARLSTON, WV 25312
 Telephone Number: 304-541-9956
 Project Name: WASTE WATER TREATMENT PLANT
 Project Description: NEW PLANT CONSTRUCTION



State of West Virginia
DRUG FREE WORKPLACE CONFORMANCE AFFIDAVIT
West Virginia Code §21-1D-5

STATE OF WEST VIRGINIA

COUNTY OF KANAWHA, TO-WIT:

I, D. SHAWN WHEELER, after being first duly sworn, depose and state as follows:

- 1. I am an employee of BROWN ELECTRIC CO., INC.; and,
(Company Name)
- 2. I do hereby attest that BROWN ELECTRIC CO., INC.
(Company Name)

maintains a valid written drug free workplace policy and that such policy is in compliance with **West Virginia Code §21-1D-5**.

The above statements are sworn to under the penalty of perjury.

BROWN ELECTRIC CO., INC.
(Company Name)

By: [Signature]

Title: CHIEF OPERATING OFFICER

Date: APRIL 6, 2009

Taken, subscribed and sworn to before me this 6th day of April.

By Commission expires 3/22/2016

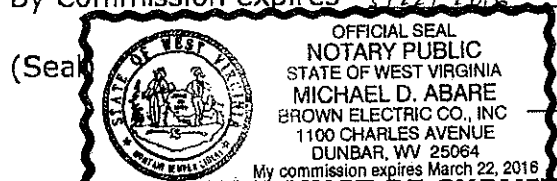

Michael D. Abare
(Notary Public)

THIS AFFIDAVIT MUST BE SUBMITTED WITH THE BID IN ORDER TO COMPLY WITH WV CODE PROVISIONS. FAILURE TO INCLUDE THE AFFIDAVIT WITH THE BID SHALL RESULT IN DISQUALIFICATION OF THE BID.

STATE OF WEST VIRGINIA
Purchasing Division

PURCHASING AFFIDAVIT

VENDOR OWING A DEBT TO THE STATE:

West Virginia Code §5A-3-10a provides that: No contract or renewal of any contract may be awarded by the state or any of its political subdivisions to any vendor or prospective vendor when the vendor or prospective vendor or a related party to the vendor or prospective vendor is a debtor and the debt owed is an amount greater than one thousand dollars in the aggregate

PUBLIC IMPROVEMENT CONTRACTS & DRUG-FREE WORKPLACE ACT:

If this is a solicitation for a public improvement construction contract, the vendor, by its signature below, affirms that it has a written plan for a drug-free workplace policy in compliance with Article 1D, Chapter 21 of the *West Virginia Code*. The vendor **must** make said affirmation with its bid submission. Further, public improvement construction contract may not be awarded to a vendor who does not have a written plan for a drug-free workplace policy in compliance with Article 1D, Chapter 21 of the *West Virginia Code* and who has not submitted that plan to the appropriate contracting authority in timely fashion. For a vendor who is a subcontractor, compliance with Section 5, Article 1D, Chapter 21 of the *West Virginia Code* may take place before their work on the public improvement is begun.

ANTITRUST:

In submitting a bid to any agency for the state of West Virginia, the bidder offers and agrees that if the bid is accepted the bidder will convey, sell, assign or transfer to the state of West Virginia all rights, title and interest in and to all causes of action it may now or hereafter acquire under the antitrust laws of the United States and the state of West Virginia for price fixing and/or unreasonable restraints of trade relating to the particular commodities or services purchased or acquired by the state of West Virginia. Such assignment shall be made and become effective at the time the purchasing agency tenders the initial payment to the bidder.

I certify that this bid is made without prior understanding, agreement, or connection with any corporation, firm, limited liability company, partnership or person or entity submitting a bid for the same materials, supplies, equipment or services and is in all respects fair and without collusion or fraud. I further certify that I am authorized to sign the certification on behalf of the bidder or this bid

LICENSING:

Vendors must be licensed and in good standing in accordance with any and all state and local laws and requirements by any state or local agency of West Virginia, including, but not limited to, the West Virginia Secretary of State's Office, the West Virginia Tax Department, West Virginia Insurance Commission, or any other state agencies or political subdivision. Furthermore, the vendor must provide all necessary releases to obtain information to enable the Director or spending unit to verify that the vendor is licensed and in good standing with the above entities.

CONFIDENTIALITY:

The vendor agrees that he or she will not disclose to anyone, directly or indirectly, any such personally identifiable information or other confidential information gained from the agency, unless the individual who is the subject of the information consents to the disclosure in writing or the disclosure is made pursuant to the agency's policies, procedures and rules. Vendor further agrees to comply with the Confidentiality Policies and Information Security Accountability Requirements, set forth in <http://www.state.wv.us/admin/purchase/privacy/noticeConfidentiality.pdf>.

Under penalty of law for false swearing (*West Virginia Code* §61-5-3), it is hereby certified that the vendor affirms and acknowledges the information in this affidavit and is in compliance with the requirements as stated

Vendor's Name: BEOWN ELECTRIC CO, INC
Authorized Signature: [Signature] Date: 8/3/2009

General Information

Revision
Ginny McManis-4

Switchgear Rating

Voltage Class: 15
System Voltage: 13.8
Symm Short Circuit: 25
BIL: 95 KV
Number of Wires: 3

Bus Specifications

Bus Material: Silver-Plated Copper
Ground Bus Material: Cu
Bus Bracing: 25
Main Bus Amps: 800
Bus Support Ins: Nylon Finned

Enclosure Info:

: Outdoor
Int Color: ANSI-61 Light Gray
Ext Color: ANSI-61 Light Gray

Structure Modifications

Modification Str. #s
Space Heaters 1,2
Therm; Non-Diff-Fix-Point 1,2
Operations Counter 1,2
Drive Rod; Glass Poly 1,2

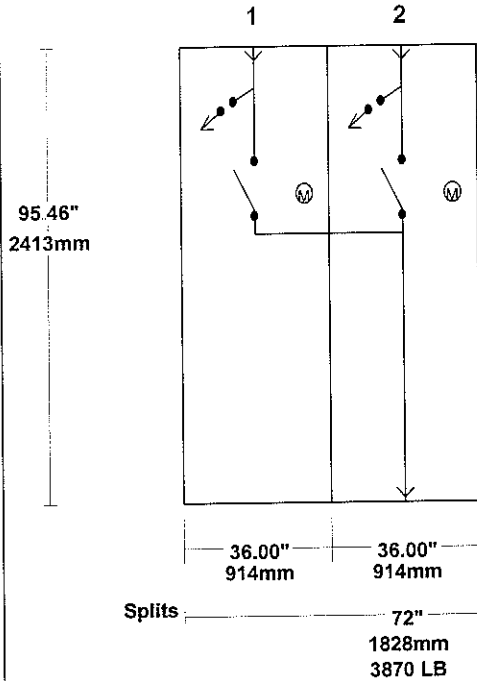

* = Special Apparatus

Structure		1	2		
Depth		55.25	55.25		
Switch Rating		600	600		
Momentary Rating		40	40		
NP Integ. Rating		25	25		
FUUSE OR VCB	Class				
	Type				
	Amps				
	Spare				
CABLE IN	Size	NEMA	NEMA		
	#/PH	2	2		
	Term Type	None	None		
CABLE OUT	Size		NEMA		
	#/PH		2		
	Term Type	None	None		
(Qty.) CT Ratio					
(Qty.) VT Ratio					
CPT Rating (KVA)		None	None		
SURGE ARREST	KV	12.0	12.0		
	TYPE	Distribution	Distribution		
KEY INTER- LOCK Inter- change(s)	QTY	2	2		
	SCHEME				
	LO				
	LD				
	LC				

The information on this document is created by Eaton Corporation. It is disclosed in confidence and it is only to be used for the purpose in which it is supplied.

PREPARED BY T148	DATE 07/14/09	Eaton Corporation		Greenwood, SC
APPROVED BY	DATE	JOB NAME BLDG 11 CHILLER ATS		
VERSION 6.8	TYPE Medium Voltage Switches	DESIGNATION	DRAWING TYPE Customer Appr.	SHEET
NEG-ALT NUMBER CR820714E903-0000	REVISION 0	DWG SIZE A	ITEM	1 OF 2

Roof Plan
Rear

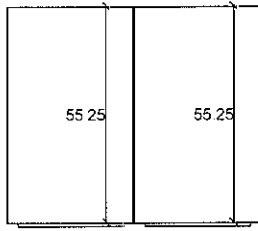

Floor Plan
Rear

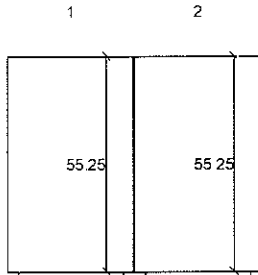

Splits
72'
1828 mm
3870 LB

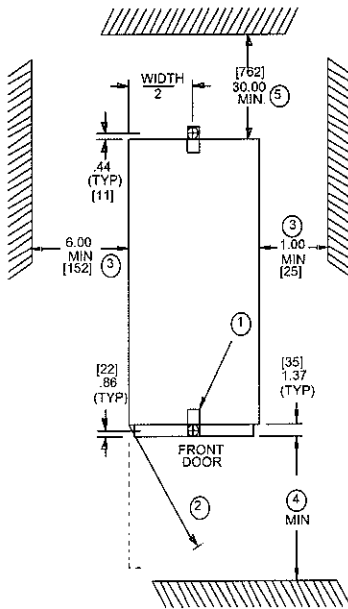

TYPICAL ANCHOR PLAN FOR UNITS

- ① LOCATIONS FOR TIE-DOWN CLIPS. PROVISIONS FOR 0.50 [13] INCH ANCHOR BOLTS
- ② DOOR SWING EQUALS UNIT WIDTH AT 90 DEGREES
- ③ MINIMUM CLEARANCES ON SIDE. LOCAL JURISDICTIONS MAY REQUIRE A LARGER CLEARANCE
- ④ MINIMUM CLEARANCES IN FRONT IS THE WIDTH OF THE WIDEST VERTICAL SECTION PLUS ONE INCH. LOCAL JURISDICTIONS MAY REQUIRE A LARGER DISTANCE.
- ⑤ MINIMUM CLEARANCES IN REAR. LOCAL JURISDICTIONS MAY REQUIRE A LARGER DISTANCE
- ⑥ FINISHED FOUNDATION'S SURFACE SHALL BE LEVEL WITHIN 0.0125 INCH (0.3175mm) IN 36 INCHES (914.4mm) LEFT-TO-RIGHT, FRONT-TO-BACK AND DIAGONALLY AS MEASURED BY A LASER LEVEL

The information on this document is created by Eaton Corporation. It is disclosed in confidence and it is only to be used for the purpose in which it is supplied

PREPARED BY
T148
APPROVED BY

DATE
07/14/09

Eaton Corporation

Greenwood, SC

JOB NAME **BLDG 11 CHILLER ATS**

DESIGNATION

VERSION
6.8

TYPE
Medium Voltage Switches

DRAWING TYPE
Customer Appr

NEG-ALT NUMBER
CR820714E903-0000

REVISION
0

DWG SIZE
A

G O

ITEM

SHEET

2 OF 2

- 1 MVS 5/15 kV Lineups
Outdoor, 15 kV Max , 13.8 kV system, kV system, 3 wires, 800A Silver-Plated Copper bus, 2 Structures,
- 2 800A Copper silver plated main bus
- 2 Copper silver plated bus
- 2 15kV Switch 600A, 40kA mom, 40kA fc
- 2 Motor Operator
- 2 2 Key Interlocks
- 2 Operations Counter
- 2 Set(s) of 12KV Distribution class surge arrester
- 2 1 Space heater per Structure
- 2 Non-Diff-Fix-Point
- 1 Auto Transfer Controls Only
- 2 Nylon Finned Insulators
- 2 Outdoor Enclosure

Comments & Exceptions

Terms and Conditions per SP 25-000.

Price - firm thru quoted shipment, fob factory, fit ppd & included.

Pricing is per the attached bill of material only Any additions or deletions to this bill of material will result in a price adjustment.

AC and DC control power source shall be provided and installed remote from the switchgear by others.

Should approval drawings be required, they will be available approximately 4-5 weeks after order entry. Shipment is approximately 6-8 weeks after release for manufacture and receipt of complete information Exact leadtime will be confirmed when the order is released for manufacture.

Cancellation Schedule:

- Factory order entry complete	15%
- Factory Drawings for approval sent	25%
- First week after approval	50%
- Factory construction drawings complete	80%
- Order released to factory floor for mfg	100%

Please note that no detailed plans and specifications were provided with this request for quotation. For ANY changes to the attached bill of materials, please contact factory for revised pricing and possibly revised footprint

Please note that no special section is required for the automatic transfer controls, therefore Eaton is only including the structures required for the switches as part of this proposal

AC control power source for motor operators and for space heaters, shall be provided and installed remote from the switchgear by others.

Designations:

All orders must be released for manufacture within 90 days of date of order entry. If approval drawings are required, drawings must be returned approved for release within 60 days of mailing. If drawings are not

BID BOND

KNOW ALL MEN BY THESE PRESENTS, That we, the undersigned Brown Electric Company, Inc.
of Dunbar WV, as Principal, and Travelers Casualty and Surety Company
of America of Hartford, CT a corporation organized and existing under the laws of the State of _____
CT with its principal office in the City of Hartford, as Surety are held and firmly bound unto the State
of West Virginia, as Obligee in the penal sum of Five Percent of Amount Bid (\$ 5%) for the payment of which,
well and truly to be made we jointly and severally bind ourselves, our heirs administrators executors successors and assigns.

The Condition of the above obligation is such that whereas the Principal has submitted to the Purchasing Section of the
Department of Administration a certain bid or proposal, attached hereto and made a part hereof, to enter into a contract in writing for
RFQ No. GSD096452 Secondary Power Feed Project Building #11 - According to Plans and Specifications

NOW THEREFORE,

- (a) If said bid shall be rejected, or
- (b) If said bid shall be accepted and the Principal shall enter into a contract in accordance with the bid or proposal attached
hereto and shall furnish any other bonds and insurance required by the bid or proposal, and shall in all other respects perform the
agreement created by the acceptance of said bid then this obligation shall be null and void, otherwise this obligation shall remain in full
force and effect It is expressly understood and agreed that the liability of the Surety for any and all claims hereunder shall, in no event,
exceed the penal amount of this obligation as herein stated

The Surety, for the value received, hereby stipulates and agrees that the obligations of said Surety and its bond shall be in no
way impaired or affected by any extension of the time within which the Obligee may accept such bid and said Surety does hereby
waive notice of any such extension

IN WITNESS WHEREOF, Principal and Surety have hereunto set their hands and seals, and such of them as are corporations
have caused their corporate seals to be affixed hereunto and these presents to be signed by their proper officers this
4th day of August, 2009

Principal Corporate Seal

Brown Electric Company, Inc.
(Name of Principal)

By: [Signature]
(Must be President or
Vice President)

D. Shawn Wheeler Vice President
(Title)

Surety Corporate Seal

Travelers Casualty and Surety Company of America
(Name of Surety)

By: [Signature]
Gregory T. Gordon WV Resident Agent Attorney-in-Fact



POWER OF ATTORNEY

Farmington Casualty Company
Fidelity and Guaranty Insurance Company
Fidelity and Guaranty Insurance Underwriters, Inc.
Seaboard Surety Company
St. Paul Fire and Marine Insurance Company

St. Paul Guardian Insurance Company
St. Paul Mercury Insurance Company
Travelers Casualty and Surety Company
Travelers Casualty and Surety Company of America
United States Fidelity and Guaranty Company

Attorney-In Fact No. 220367

Certificate No. 002993526

KNOW ALL MEN BY THESE PRESENTS: That Seaboard Surety Company is a corporation duly organized under the laws of the State of New York that St Paul Fire and Marine Insurance Company, St Paul Guardian Insurance Company and St. Paul Mercury Insurance Company are corporations duly organized under the laws of the State of Minnesota. that Farmington Casualty Company Travelers Casualty and Surety Company, and Travelers Casualty and Surety Company of America are corporations duly organized under the laws of the State of Connecticut that United States Fidelity and Guaranty Company is a corporation duly organized under the laws of the State of Maryland, that Fidelity and Guaranty Insurance Company is a corporation duly organized under the laws of the State of Iowa, and that Fidelity and Guaranty Insurance Underwriters, Inc. is a corporation duly organized under the laws of the State of Wisconsin (herein collectively called the 'Companies'), and that the Companies do hereby make, constitute and appoint

Gregory T. Gordon Patricia A Moye Larry D. Kerr, Allan L. McVey, and Kimberly J Wilkinson

of the City of Charleston State of West Virginia their true and lawful Attorney(s)-in-Fact, each in their separate capacity if more than one is named above. to sign, execute, seal and acknowledge any and all bonds recognizances conditional undertakings and other writings obligatory in the nature thereof on behalf of the Companies in their business of guaranteeing the fidelity of persons guaranteeing the performance of contracts and executing or guaranteeing bonds and undertakings required or permitted in any actions or proceedings allowed by law.

IN WITNESS WHEREOF, the Companies have caused this instrument to be signed and their corporate seals to be hereto affixed, this 8th day of May 2009

Farmington Casualty Company
Fidelity and Guaranty Insurance Company
Fidelity and Guaranty Insurance Underwriters, Inc.
Seaboard Surety Company
St. Paul Fire and Marine Insurance Company

St. Paul Guardian Insurance Company
St. Paul Mercury Insurance Company
Travelers Casualty and Surety Company
Travelers Casualty and Surety Company of America
United States Fidelity and Guaranty Company



State of Connecticut
City of Hartford ss

By: [Signature]
George W. Thompson Senior Vice President

On this the 8th day of May, 2009, before me personally appeared George W. Thompson, who acknowledged himself to be the Senior Vice President of Farmington Casualty Company, Fidelity and Guaranty Insurance Company, Fidelity and Guaranty Insurance Underwriters Inc, Seaboard Surety Company St Paul Fire and Marine Insurance Company, St Paul Guardian Insurance Company, St Paul Mercury Insurance Company, Travelers Casualty and Surety Company Travelers Casualty and Surety Company of America and United States Fidelity and Guaranty Company, and that he as such, being authorized so to do, executed the foregoing instrument for the purposes therein contained by signing on behalf of the corporations by himself as a duly authorized officer

In Witness Whereof, I hereunto set my hand and official seal
My Commission expires the 30th day of June 2011



[Signature]
Marie C. Tetreault, Notary Public