



State of West Virginia  
 Department of Administration  
 Purchasing Division  
 2019 Washington Street East  
 Post Office Box 50130  
 Charleston, WV 25305-0130

**Request for Quotation**

RFQ NUMBER  
 DNR210184

PAGE  
 1

ADDRESS CORRESPONDENCE TO ATTENTION OF  
 FRANK WHITTAKER  
 304-558-2316

RFQ COPY

VENDOR

1 Longs' Security Camera Systems  
 LLC  
 102 38th Street SE  
 Charleston, WV 25304

SHIP TO

DIVISION OF NATURAL RESOURCES  
 TWIN FALLS RESORT STATE PARK  
 ATTN: PARK SUPERINTENDENT  
 RT. 97, PO BOX 667  
 MULLENS, WV  
 25882 304-294-6000

DATE PRINTED	TERMS OF SALE	SHIP VIA	F.O.B.	FREIGHT TERMS
03/31/2010				

BID OPENING DATE: 04/27/2010 BID OPENING TIME 01:30PM

LINE	QUANTITY	UOP	CAT NO	ITEM NUMBER	UNIT PRICE	AMOUNT
0001	1	EA		045-06		
APPLIANCES, ELECTRIC (SMALL, HOUSEHOLD)  THE WEST VIRGINIA PURCHASING DIVISION, FOR THE AGENCY, THE WEST VIRGINIA DIVISION OF NATURAL RESOURCES IS SOLICITING BIDS FOR AN OPEN-END CONTRACT TO PROVIDE APPLIANCES, TELEVISIONS, AND ACCESSORIES FOR GUEST ROOMS AT TWIN FALL RESORT STATE PARK PER THE ATTACHED SPECIFICATIONS.  ALL TECHNICAL QUESTIONS MUST BE SUBMITTED IN WRITING TO FRANK WHITTAKER IN THE PURCHASING DIVISION VIA EMAIL AT FRANK.M.WHITTAKER@WV.GOV OR VIA FAX AT 304-558-4115. DEADLINE FOR TECHNICAL QUESTIONS IS CLOSE OF BUSINESS 04/12/2010. ALL TECHNICAL QUESTIONS WILL BE ADDRESSED BY ADDENDUM AFTER THE DEADLINE.  EXHIBIT 3  LIFE OF CONTRACT: THIS CONTRACT BECOMES EFFECTIVE ON ..... AND EXTENDS FOR A PERIOD OF ONE (1) YEAR OR UNTIL SUCH "REASONABLE TIME" THEREAFTER AS IS NECESSARY TO OBTAIN A NEW CONTRACT OR RENEW THE ORIGINAL CONTRACT. THE "REASONABLE TIME" PERIOD SHALL NOT EXCEED TWELVE (12) MONTHS. DURING THIS "REASONABLE TIME" THE VENDOR MAY TERMINATE THIS CONTRACT FOR ANY REASON UPON GIVING THE DIRECTOR OF PURCHASING 30 DAYS WRITTEN NOTICE.  UNLESS SPECIFIC PROVISIONS ARE STIPULATED ELSEWHERE IN THIS CONTRACT DOCUMENT, THE TERMS, CONDITIONS AND PRICING SET HEREIN ARE FIRM FOR THE LIFE OF THE						

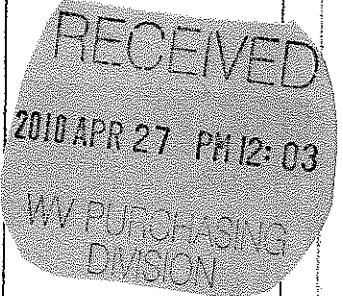

SEE REVERSE SIDE FOR TERMS AND CONDITIONS

SIGNATURE *Alan C Long* TELEPHONE 304-925-0338 DATE 4/27/2010  
 TITLE Owner FEIN 20-3881880 ADDRESS CHANGES TO BE NOTED ABOVE

WHEN RESPONDING TO RFQ, INSERT NAME AND ADDRESS IN SPACE ABOVE LABELED 'VENDOR'



State of West Virginia  
 Department of Administration  
 Purchasing Division  
 2019 Washington Street East  
 Post Office Box 50130  
 Charleston, WV 25305-0130

# Request for Quotation

RFQ NUMBER  
**DNR210184**

PAGE  
**2**

ADDRESS CORRESPONDENCE TO ATTENTION OF  
**FRANK WHITTAKER**  
**304-558-2316**

RFQ COPY

TYPE NAME/ADDRESS HERE

SHIP TO

DIVISION OF NATURAL RESOURCES  
 TWIN FALLS RESORT STATE PARK  
 ATTN: PARK SUPERINTENDENT  
 RT. 97, PO BOX 667  
 MULLENS, WV  
 25882 304-294-6000

DATE PRINTED	TERMS OF SALE	SHIP VIA	F.O.B.	FREIGHT TERMS
03/31/2010				

BID OPENING DATE: **04/27/2010** BID OPENING TIME **01:30PM**

LINE	QUANTITY	UOP	CAT NO	ITEM NUMBER	UNIT PRICE	AMOUNT
<p>CONTRACT.</p> <p>RENEWAL: THIS CONTRACT MAY BE RENEWED UPON THE MUTUAL WRITTEN CONSENT OF THE SPENDING UNIT AND VENDOR, SUBMITTED TO THE DIRECTOR OF PURCHASING THIRTY (30) DAYS PRIOR TO THE EXPIRATION DATE. SUCH RENEWAL SHALL BE IN ACCORDANCE WITH THE TERMS AND CONDITIONS OF THE ORIGINAL CONTRACT AND SHALL BE LIMITED TO TWO (2) ONE (1) YEAR PERIODS.</p> <p>CANCELLATION: THE DIRECTOR OF PURCHASING RESERVES THE RIGHT TO CANCEL THIS CONTRACT IMMEDIATELY UPON WRITTEN NOTICE TO THE VENDOR IF THE COMMODITIES AND/OR SERVICES SUPPLIED ARE OF AN INFERIOR QUALITY OR DO NOT CONFORM TO THE SPECIFICATIONS OF THE BID AND CONTRACT HEREIN.</p> <p>OPEN MARKET CLAUSE: THE DIRECTOR OF PURCHASING MAY AUTHORIZE A SPENDING UNIT TO PURCHASE ON THE OPEN MARKET, WITHOUT THE FILING OF A REQUISITION OR COST ESTIMATE, ITEMS SPECIFIED ON THIS CONTRACT FOR IMMEDIATE DELIVERY IN EMERGENCIES DUE TO UNFORESEEN CAUSES (INCLUDING BUT NOT LIMITED TO DELAYS IN TRANSPORTATION OR AN UNANTICIPATED INCREASE IN THE VOLUME OF WORK.)</p> <p>QUANTITIES: QUANTITIES LISTED IN THE REQUISITION ARE APPROXIMATIONS ONLY, BASED ON ESTIMATES SUPPLIED BY THE STATE SPENDING UNIT. IT IS UNDERSTOOD AND AGREED THAT THE CONTRACT SHALL COVER THE QUANTITIES ACTUALLY ORDERED FOR DELIVERY DURING THE TERM OF THE CONTRACT, WHETHER MORE OR LESS THAN THE QUANTITIES SHOWN.</p> <p>ORDERING PROCEDURE: SPENDING UNIT(S) SHALL ISSUE A WRITTEN STATE CONTRACT ORDER (FORM NUMBER WV-39) TO THE VENDOR FOR COMMODITIES COVERED BY THIS CONTRACT. THE ORIGINAL COPY OF THE WV-39 SHALL BE MAILED TO THE</p>						

SEE REVERSE SIDE FOR TERMS AND CONDITIONS

SIGNATURE <i>Alan E. [Signature]</i>	TELEPHONE <b>304-925-0330</b>	DATE <b>4/27/2010</b>
TITLE <b>Owner</b>	FEN <b>20-3801880</b>	ADDRESS CHANGES TO BE NOTED ABOVE

WHEN RESPONDING TO RFQ, INSERT NAME AND ADDRESS IN SPACE ABOVE LABELED 'VENDOR'



State of West Virginia  
 Department of Administration  
 Purchasing Division  
 2019 Washington Street East  
 Post Office Box 50130  
 Charleston, WV 25305-0130

# Request for Quotation

RFQ NUMBER  
 DNR210184

PAGE  
 3

ADDRESS CORRESPONDENCE TO ATTENTION OF  
 FRANK WHITTAKER  
 304-558-2316

VENDOR

RFQ COPY  
 TYPE NAME/ADDRESS HERE

SHIP TO

DIVISION OF NATURAL RESOURCES  
 TWIN FALLS RESORT STATE PARK  
 ATTN: PARK SUPERINTENDENT  
 RT. 97, PO BOX 667  
 MULLENS, WV 25882  
 304-294-6000

DATE PRINTED	TERMS OF SALE	SHIP VIA	F.O.B.	FREIGHT TERMS
03/31/2010				

BID OPENING DATE: 04/27/2010 BID OPENING TIME 01:30PM

LINE	QUANTITY	UOP	CAT NO	ITEM NUMBER	UNIT PRICE	AMOUNT
<p>VENDOR AS AUTHORIZATION FOR SHIPMENT, A SECOND COPY MAILED TO THE PURCHASING DIVISION, AND A THIRD COPY RETAINED BY THE SPENDING UNIT.</p> <p>BANKRUPTCY: IN THE EVENT THE VENDOR/CONTRACTOR FILES FOR BANKRUPTCY PROTECTION, THE STATE MAY DEEM THE CONTRACT NULL AND VOID, AND TERMINATE SUCH CONTRACT WITHOUT FURTHER ORDER.</p> <p>THE TERMS AND CONDITIONS CONTAINED IN THIS CONTRACT SHALL SUPERSEDE ANY AND ALL SUBSEQUENT TERMS AND CONDITIONS WHICH MAY APPEAR ON ANY ATTACHED PRINTED DOCUMENTS SUCH AS PRICE LISTS, ORDER FORMS, SALES AGREEMENTS OR MAINTENANCE AGREEMENTS, INCLUDING ANY ELECTRONIC MEDIUM SUCH AS CD-ROM.</p> <p>REV. 05/26/2009 EXHIBIT 4</p> <p>LOCAL GOVERNMENT BODIES: UNLESS THE VENDOR INDICATES IN THE BID HIS REFUSAL TO EXTEND THE PRICES, TERMS, AND CONDITIONS OF THE BID TO COUNTY, SCHOOL, MUNICIPAL AND OTHER LOCAL GOVERNMENT BODIES, THE BID SHALL EXTEND TO POLITICAL SUBDIVISIONS OF THE STATE OF WEST VIRGINIA. IF THE VENDOR DOES NOT WISH TO EXTEND THE PRICES, TERMS, AND CONDITIONS OF THE BID TO ALL POLITICAL SUBDIVISIONS OF THE STATE, THE VENDOR MUST CLEARLY INDICATE SUCH REFUSAL IN HIS BID. SUCH REFUSAL SHALL NOT PREJUDICE THE AWARD OF THIS CONTRACT IN ANY MANNER.</p> <p>REV. 3/88</p> <p style="text-align: center;">NOTICE</p> <p>A SIGNED BID MUST BE SUBMITTED TO:</p>						

SEE REVERSE SIDE FOR TERMS AND CONDITIONS

SIGNATURE <i>Frank Whittaker</i>	TELEPHONE 304-925-0338	DATE 4-27-2010
TITLE Owner	FEIN 20-3881880	ADDRESS CHANGES TO BE NOTED ABOVE

WHEN RESPONDING TO RFQ, INSERT NAME AND ADDRESS IN SPACE ABOVE LABELED 'VENDOR'



State of West Virginia  
 Department of Administration  
 Purchasing Division  
 2019 Washington Street East  
 Post Office Box 50130  
 Charleston, WV 25305-0130

# Request for Quotation

RFQ NUMBER  
 DNR210184

PAGE  
 4

ADDRESS CORRESPONDENCE TO ATTENTION OF  
 FRANK WHITTAKER  
 304-558-2316

PURCHASING DIVISION

RFQ COPY  
 TYPE NAME/ADDRESS HERE

SHIP TO

DIVISION OF NATURAL RESOURCES  
 TWIN FALLS RESORT STATE PARK  
 ATTN: PARK SUPERINTENDENT  
 RT. 97, PO BOX 667  
 MULLENS, WV  
 25882 304-294-6000

DATE PRINTED	TERMS OF SALE	SHIP VIA	F.O.B.	FREIGHT TERMS
03/31/2010				

BID OPENING DATE: 04/27/2010 BID OPENING TIME 01:30PM

LINE	QUANTITY	UOP	CAT NO	ITEM NUMBER	UNIT PRICE	AMOUNT
DEPARTMENT OF ADMINISTRATION PURCHASING DIVISION BUILDING 15 2019 WASHINGTON STREET, EAST CHARLESTON, WV 25305-0130						
THE BID SHOULD CONTAIN THIS INFORMATION ON THE FACE OF THE ENVELOPE OR THE BID MAY NOT BE CONSIDERED:						
SEALED BID						
BUYER:				44		
RFQ. NO.:				DNR210184		
BID OPENING DATE:				04/27/2010		
BID OPENING TIME:				1:30		
PLEASE PROVIDE A FAX NUMBER IN CASE IT IS NECESSARY TO CONTACT YOU REGARDING YOUR BID:						
304-925-0338						
CONTACT PERSON (PLEASE PRINT CLEARLY):						
ALAN E. LONG						

SEE REVERSE SIDE FOR TERMS AND CONDITIONS

SIGNATURE <i>Alan E Long</i>	TELEPHONE 304-925-0338	DATE 4-27-2010
TITLE Owner	FEIN 20-3881880	ADDRESS CHANGES TO BE NOTED ABOVE

WHEN RESPONDING TO RFQ, INSERT NAME AND ADDRESS IN SPACE ABOVE LABELED 'VENDOR'

Purchase, Assembly, and Set Up of Guest Room Appliances, Televisions, and Accessories  
 Open End Contract  
**MANUFACTURER'S LIST**

Please complete the below information concerning the brand(s) of equipment being bid in relation to this project. If bidding in or equal inch brands, please attach manufacturer's literature documenting that it meets the mandatory requirements stated in the specifications. Vendors should note the areas of the provided manufacturer's literature that adheres to the mandatory requirements outlined in the Request For Quotation.

Item	Description	Manufacturer	Item No.
1	Sanyo 800W, 0.7 cubic feet compact microwave, or equal.	Sanyo	EM-S2588B
2	Sanyo 3.6 cubic feet refrigerator/freezer, Model #SR-3620K, or equal.	Sanyo	SR-3620K
3	Samsung 32" LCD HD TV, or equal.	LG	32LH250H
4	Pivot wall mount, Peerless Model #SP740P, or equal.	VideoSecu	ML520B
5	Universal tilt wall mount, Peerless Model #ST640, or equal.	Cheetah Mounts	APTMM2B

Life of Contract : Please note that market conditions may affect the availability of the listed products. LSCS reserves the right to substitute the list products for market available products with products that meet or exceed current specifications.

DNR210184  
Twin Falls Resort State Park  
Guest Room Appliances, Televisions, and Accessories  
Purchase, Assembly and Set-Up  
Open End Contract  
**PRICING SHEET**

Item No.	Estimated Quantity	Description	Unit Price	Amount
1	27	Sanyo 800W, 0.7 cubic feet compact microwave, or equal.	\$ 81.00	\$2,187.00
2	27	Sanyo 3.6 cubic feet refrigerator/freezer, Model #SR-3620K, or equal.	\$ 214.00	\$ 5,778.00
3	27	Samsung 32" LCD HD TV, or equal.	\$ 890	\$ 24,030.00
4	3	Peerless Model #SP740P, Pivot wall mount, or equal.	\$ 80.00	\$ 240.00
5	27	Peerless Model #ST640, Universal tilt wall mount, ,or equal.	\$ 50.00	\$ 1,350.00
<b>TOTALS</b>				\$ 33,585

The quantities listed above are for bid evaluation purposes only.  
Actual quantities may differ.

*Includes all labor, materials and disposal of debris to install the appliances.*

# VENDOR PREFERENCE CERTIFICATE

Certification and application\* is hereby made for Preference in accordance with *West Virginia Code*, §5A-3-37. (Does not apply to construction contracts) *West Virginia Code*, §5A-3-37, provides an opportunity for qualifying vendors to request (at the time of bid) preference for their residency status. Such preference is an evaluation method only and will be applied only to the cost bid in accordance with the *West Virginia Code*. This certificate for application is to be used to request such preference. The Purchasing Division will make the determination of the Resident Vendor Preference, if applicable.

- 1.  Application is made for 2.5% resident vendor preference for the reason checked:  
 Bidder is an individual resident vendor and has resided continuously in West Virginia for four (4) years immediately preceding the date of this certification; or,  
 Bidder is a partnership, association or corporation resident vendor and has maintained its headquarters or principal place of business continuously in West Virginia for four (4) years immediately preceding the date of this certification; or 80% of the ownership interest of Bidder is held by another individual, partnership, association or corporation resident vendor who has maintained its headquarters or principal place of business continuously in West Virginia for four (4) years immediately preceding the date of this certification; or,  
 Bidder is a nonresident vendor which has an affiliate or subsidiary which employs a minimum of one hundred state residents and which has maintained its headquarters or principal place of business within West Virginia continuously for the four (4) years immediately preceding the date of this certification; or;
- 2.  Application is made for 2.5% resident vendor preference for the reason checked:  
 Bidder is a resident vendor who certifies that, during the life of the contract, on average at least 75% of the employees working on the project being bid are residents of West Virginia who have resided in the state continuously for the two years immediately preceding submission of this bid; or;
- 3.  Application is made for 2.5% resident vendor preference for the reason checked:  
 Bidder is a nonresident vendor employing a minimum of one hundred state residents or is a nonresident vendor with an affiliate or subsidiary which maintains its headquarters or principal place of business within West Virginia employing a minimum of one hundred state residents who certifies that, during the life of the contract, on average at least 75% of the employees or Bidder's affiliate's or subsidiary's employees are residents of West Virginia who have resided in the state continuously for the two years immediately preceding submission of this bid; or;
- 4.  Application is made for 5% resident vendor preference for the reason checked:  
 Bidder meets either the requirement of both subdivisions (1) and (2) or subdivision (1) and (3) as stated above; or;
- 5.  Application is made for 3.5% resident vendor preference who is a veteran for the reason checked:  
 Bidder is an individual resident vendor who is a veteran of the United States armed forces, the reserves or the National Guard and has resided in West Virginia continuously for the four years immediately preceding the date on which the bid is submitted; or;
- 6.  Application is made for 3.5% resident vendor preference who is a veteran for the reason checked:  
 Bidder is a resident vendor who is a veteran of the United States armed forces, the reserves or the National Guard, if, for purposes of producing or distributing the commodities or completing the project which is the subject of the vendor's bid and continuously over the entire term of the project, on average at least seventy-five percent of the vendor's employees are residents of West Virginia who have resided in the state continuously for the two immediately preceding years

Bidder understands if the Secretary of Revenue determines that a Bidder receiving preference has failed to continue to meet the requirements for such preference, the Secretary may order the Director of Purchasing to: (a) reject the bid; or (b) assess a penalty against such Bidder in an amount not to exceed 5% of the bid amount and that such penalty will be paid to the contracting agency or deducted from any unpaid balance on the contract or purchase order

By submission of this certificate, Bidder agrees to disclose any reasonably requested information to the Purchasing Division and authorizes the Department of Revenue to disclose to the Director of Purchasing appropriate information verifying that Bidder has paid the required business taxes, provided that such information does not contain the amounts of taxes paid nor any other information deemed by the Tax Commissioner to be confidential.

Under penalty of law for false swearing (*West Virginia Code*, §61-5-3), Bidder hereby certifies that this certificate is true and accurate in all respects; and that if a contract is issued to Bidder and if anything contained within this certificate changes during the term of the contract, Bidder will notify the Purchasing Division in writing immediately.

Bidder: Long's Security Camera Systems LLC      Signed: Alan E. Ohry  
Date: 4-27-10      Title: Owner

\*Check any combination of preference consideration(s) indicated above, which you are entitled to receive

32" CLASS (31.5" DIAGONAL)

32LH255H

MATTE BLACK

32LH250H

HI GLOSS BLACK

LCD TV

## LCD Commercial Widescreen Integrated HDTV with HD-PPV Capability

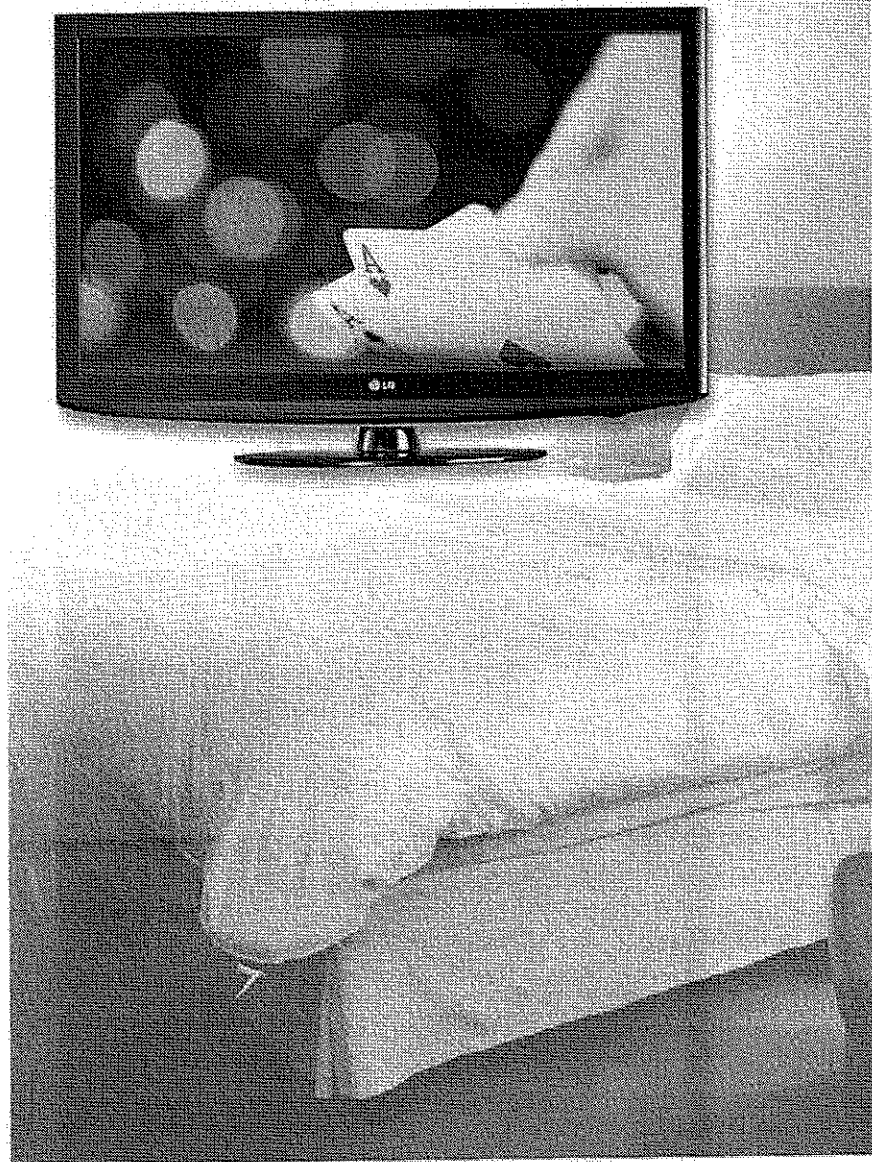

### NEW! BUILT-IN e-LAN

Includes full support of:  
LodgeNet's HD Video on Demand (VOD)  
LodgeNet's HD Free-To-Guest (FTG)  
Supports many other FTG system providers  
(see sales rep)  
Compatible with FMA-100

 EcoSmart™  
Dynamic Power Savings  
Static Power Savings

 ENERGY STAR® 3.0 AND RoHS COMPLIANT

HD VOD PPV ENCRYPTION  
Integrated Pro:Idiom®

MPEG-2/MPEG-4 H.264 DECODING

DYNAMIC CONTRAST RATIO  
20,000:1

NATIVE DISPLAY RESOLUTION  
1366 x 768

BUILT-IN ATSC/NTSC/QAM CLEAR TUNER

INVISIBLE SPEAKER SYSTEM  
Hidden speaker grilles

180° DETACHABLE SWIVEL STAND

LG'S EXCLUSIVE XD ENGINE®

USB 2.0 MEDIA HOST FOR PHOTOS AND MUSIC

USB CLONING

CLEAR VOICE II

REAL CINEMA™

2 HDMI™ INPUTS WITH HDCP  
V.1.3 with deep color

AUTO SENSING REMOTE JACK PACK (RJP) COMPATIBLE\*

2 YEAR LIMITED WARRANTY  
(parts and labor)

\*NOTE: Contact your LG Sales representative on the RJPs that are compatible with the LH250H/LH255H series.

[www.LGcommercial.com](http://www.LGcommercial.com)

 **LG**  
Life's Good





green LIFE'S GOOD...

# WHEN IT'S GREEN.

LG is committed to improving product development, manufacturing and usage to meet the demand for environmentally friendlier products. Our LH250H/LH255H series televisions have technologies to reduce power consumption and in return increase **cost savings** per room. We've also placed limits in the amounts of harmful materials used in these televisions.

### EcoSmart

**Dynamic Power Savings** - Using built-in algorithms, TV will automatically reduce the power consumption based on incoming video, while maximizing picture performance.

**Static Power Savings** - Picture brightness level can be set at the preferred power consumption level to reduce power and increase energy savings.

### ENERGY STAR 3.0 Compliant

Meets current reduction requirements of energy consumption.

### RoHS Compliant

Meets directive on restriction of hazardous substances.

## LG'S FREE-TO-GUEST COST EFFECTIVE SOLUTION

For Free-To-Guest hotel installations, when using LG's LMT7Z7 Free-To-Guest built-in technology plus LG's Free-to-Guest Management Appliance (FMA), virtual channel mapping and other adjustments can be made from the centralized head-end FMA system. This is an added value of time savings and therefore cost savings in labor charges by not having to go room to room for a change of settings.

## HOTEL COSTS FOR FREE-TO-GUEST CHANNEL MANAGEMENT (OVER 5 YEARS)

	Labor Costs	*FMA MAP price	Total	Savings over other brand
Other brand	\$20 (est.) x 2 times per year (to update channels) x 100 rooms x 5 years		\$20,000	
LG ProLidion TV (LH250H/LH255H) with LMT7Z7 technology built-in, plus FMA		\$1,999	\$1,999	\$18,001

\* FMA MAP price subject to change.

## ENERGY SAVING LEVELS

By selecting lower levels of backlight settings, a reduction in power consumption is achieved resulting in energy savings and lower costs.

## TESTING CONDITION IN VIVID/STATIC MODE

Applied Model	Backlight Setting Value	Brightness/Static [cd/m²]	Power Consumption [Watts]	Energy savings [%]
32LH255H 32LH250H	Level 100	314.0	111.6	0.0%
	90	283.0	102.0	8.6%
	80	248.0	93.0	16.7%
	70	222.0	86.4	22.6%
	60	198.0	79.4	28.9%
	50	176.5	72.9	34.7%
	40	149.0	66.0	40.9%
	30	116.0	58.2	47.8%
	20	81.0	51.0	54.3%
	10	58.5	42.8	61.6%
	1	30.0	37.2	66.7%

Note: Power consumption was measured with video signal: IEC62087 dynamic broadcast. Energy Saving percentages listed are based on Energy Saving percentages are based off of level 100.

## FREE-TO-GUEST MANAGEMENT APPLIANCE

### FMA HEAD-END SYSTEM



Manages channel line-up changes, channel label changes, designates a startup channel, and can set the time/date, and broadcast that information to all the terminals on a regular basis. Also, enables ProLidion tuning for ProLidion encrypted content. Works in conjunction with installed LMT7Z7 FTG card and sets with built-in LMT7Z7 technology.

## FREE-TO-GUEST LMT7Z7 TECHNOLOGY BUILT-IN

### LMT7Z7 FREE-TO-GUEST TECHNOLOGY

Will allow viewing of HD secured ProLidion encrypted content from ProLidion licensed Cable or Satellite providers. Compatible with FMA-100 system. Pay-Per-View ready.

## USB 2.0 MEDIA HOST

USB 2.0 will support JPG and MP3 files from a USB storage device.

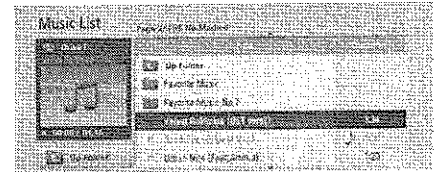
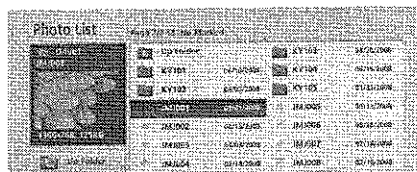

# XD ENGINE

SHARPER  
BRIGHTER  
CLEARER

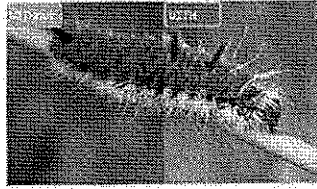

Dramatization



Dramatization

Six distinct processes contribute to picture improvement. LG's XD Engine takes the low resolution of analog signals to near HD levels by improving brightness, contrast, detail and enhancing color as well as reducing signal noise.

## invisible SPEAKER

### SOUND IS HEARD, NOT SEEN

Enjoy a combination of smart technology and stylish design with the invisible speaker system custom-tuned by audio expert Mr. Mark Levinson. This unique system provides a clean, polished look and an enhanced auditory experience by increasing the sweet spot and providing a wider sound field.

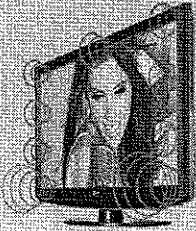

### USB CLONING

USB cloning will allow for easy transfer of Public Display Settings from the "Master TV" to an unlimited number of same type televisions.

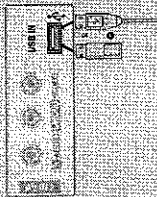

### MOUNTING HOLES ON STAND ATTACHING THE TV TO A DESK

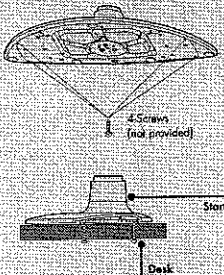

# DIMENSIONS

32LH255H  
32LH250H

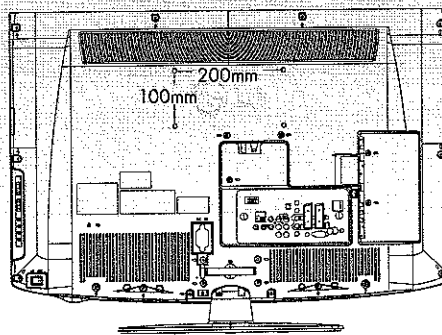
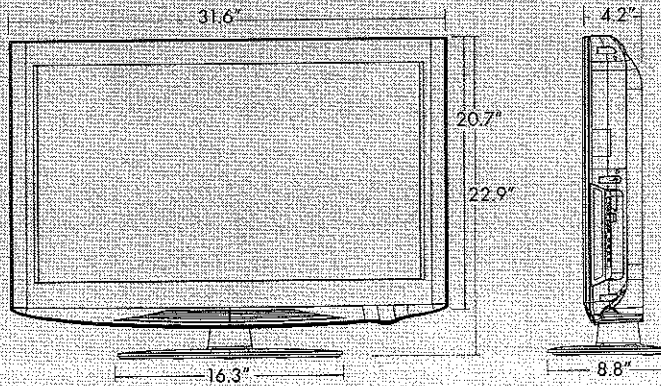

### MPI SLOT REAR JACK PANEL

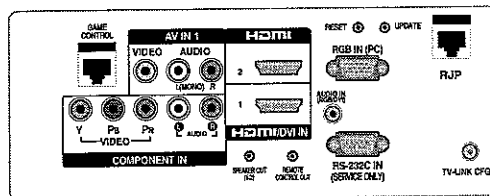
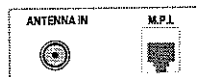

### SIDE JACK PANEL





32LH255H  
MATTE BLACK  
32LH250H  
HI GLOSS BLACK

32" CLASS (31.5" DIAGONAL)

SPECIFICATIONS

**LCD SPECIFICATION**

Screen Size (Class)	32" class (31.5" diagonal)
Native Display Resolution	1366 x 768
Brightness	500 cd/m <sup>2</sup>
Dynamic Contrast Ratio	20,000:1
Viewing Angle	178°/178°
Color Reproduction	8 Bit
Response Time	5ms
Life Span (Typical)	50,000 hrs

**BROADCASTING SYSTEM**

Analog	Yes
ATSC/NTSC/Clear QAM	Yes
b-LAN (RF Modem)	Yes

**VIDEO**

XD Engine	Yes
Video Codec	MPEG-2/4
Aspect Ratio	16:9
Aspect Ratio Correction	5 Modes
Just Scan 0% over scan	Yes
HDMI/Component	HD/DTV
Enhanced Noise Reduction (Video Noise Filter)	Yes, 3D NR/MPEG NR
Digital Comb Filter	Yes (3D)
Color Temperature Control	3 Modes (Medium, Warm, Cool)
Black Stretcher	Yes
24p Real Cinema	Yes
Cinema 3:2/2:2 Mode	Yes
Picture Reset	Yes
EZ Picture/PSM	Yes (6 mode)
xvYCC (richer color)	Yes
DTV Signal Strength Indicator	Yes
Video Reset/Initializing	Yes

**AUDIO**

Mono/Stereo/Dual (MTS/SAP)	Yes
Audio Output Power	10W x 2
Invisible Speaker System Details	1 Way 2 Speaker
Dolby Digital 5.1 Decoder	Yes
Surround System Type	SRS TruSurround XT
Bass/Treble/Balance Controls	Yes
Clear Voice II	Yes
Auto Volume Leveler	Yes
EZ Sound Mode/SSM	5 Modes

**SPECIAL FEATURES**

Integrated Pro:Idiom	Yes
Auto-Sensing RIP compatible	Yes (with select RIP versions, non-PIP)
Backlight Control	Yes
USB Cloning	Yes
1080p Source Input	Yes
HDMI Component	60f/30f/24f 60f/30f/29f
Auto Screen Adjust	Yes
Fresh White	Yes
Flashback (Previous Channel)	Yes
Quick Setup Guide	Yes
Parental Control w/V-Chip	Yes
Key Lock/Child Lock	Yes
Customizable Closed Caption/Subtitle	Yes

**CONVENIENCE FEATURES**

Language	English/Spanish/French
Alvin UI	Yes
Commercial Function Menu	Yes
Auto Tuning/Programming	Yes
Channel Add/Delete	Yes
Channel Labeling	Yes
Favorite Channel Programming	Yes
Auto/Manual Clock	Yes
On/Off Timer	Yes
Sleep Timer	Yes
Auto Off/Auto Sleep (When no video is present)	Yes

**AUDIO/VIDEO INPUTS/OUTPUTS**

RF In (Antenna/Cable)	1
L/R Audio/Composite Video In	1 (rear), 1 (side)
HD Component Video In (Y, Pb, Pr) + L/R Audio	1
Speaker Out	1 (1W mono)
HDMI/HDCP Input (V1.3 with Deep Color)	2 (1 port PC mode)
RGB In (D-Sub 15pin) - PC	1 (up to WXGA)
PC Audio Input	1
RS-232c In (Service Only)	1
USB 2.0 Input	1 (Side) Media Host (jpeg, mp3), Cloning, Service

Remote Control Port out	1
RJ45 (for RIP interface, non PIP)	1
MPI Jack (RJ-12)	1 on MPI Card Slot
Game Port (RJ-12)	1 for LodgeNet game controller
TV-LINK CFG (b-LAN phone MPI jack)	1

**CABINET/ACCESSORIES**

Cabinet Color	Glossy Black, Hi Gloss Black (LH250H), Matte Black (LH255H)
Swivel Stand (degrees)	+90°/-90°
Fire Retardant Cabinet Material	Yes
Kensington Security System Slot	Yes
Security Screws (TORX)	Yes (optional use)
VESA® Compliant (WxH)	200mm x 100mm, M4 screw
Remote Control	Yes
Cloning Capable	USB input, opt. LT2002, or opt. TL-1100A

**POWER**

Voltage, Hz	100V - 240V, 50/60 Hz
Stand-by Mode	Less than 1W
Dynamic/Static Power Savings	Yes
Power Consumption (with Power Saving Modes disabled)	Max 150W Typical 120W
ENERGY STAR 3.0 Compliant	Yes
RoHS Compliant	Yes

**DIMENSIONS & WEIGHT**

TV without stand (WxHxD)	31.6" x 20.7" x 4.2"
TV with stand (WxHxD)	31.6" x 22.9" x 8.8"
Shipping Dimensions (WxHxD)	38.7" x 24.6" x 7.4"
TV without stand weight	25.1 lbs
TV with stand weight	27.7 lbs
Shipping Weight	29.1 lbs

**SERVICE/LIMITED WARRANTY**

UPC CODE	
32LH255H	7 19192 17616 4
32LH250H	7 19192 17615 7

www.lgcommercial.com

LG Electronics U.S.A., Inc.  
Business Solutions Division  
2000 Millbrook Drive  
Lincolnshire, IL 60069

Customer Service: 888.865.3026

Contact your LG Regional Sales Representative  
Hospitality: 800.228.1236  
Enterprise: 800.897.8788  
Channel: 800.897.8871  
E-mail: lgcommercial@lge.com

SPEC\_LH250\_55H\_011021\_PR



All screen images are simulated. Dimensions and weights are approximate. Design, features and specifications subject to change without notice.

© Copyright 2010 LG Electronics USA, Inc. All Rights Reserved. "LG Life's Good" is a registered trademark of LG Corp. XD Engine is a registered trademark of LG Electronics, Inc. EcoSmart is a trademark of LG Corp. Pro:Idiom is a registered trademark of Zenith Electronics Corp. SRS and the SRS symbol and TruSurround XT are trademarks or registered trademarks of SRS Labs, Inc. VESA is a trademark of Video Electronics Standards Association. ENERGY STAR is a registered trademark of the U.S. Environmental Protection Agency. All other product and brand names are trademarks or registered trademarks of their respective companies.

Printed in the USA. January 2010



Hi, longscctv. Not longscctv? [Click here.](#)

[Track Your Order](#) | [My Account](#) | [Wishlist](#) | [Help](#)

Buy.com

[Advanced](#)

[Products](#) [Deals](#) [BuyTV](#) [News and Reviews](#)

0 item(s): \$0.00 [View Cart](#)

[Computers](#) > [Shop by Brand](#) | [Rebate Center](#) | [Find Amazing Deals from Dell](#)

[Go Green with Buy.com! Learn More >>](#)

### LG 32LH250H LCD TV

32" - ATSC - NTSC - 178° / 178° - 16:9 - 1366 x 768 - Surround - HDTV - 1080p

Other products by: [LG Electronics](#)

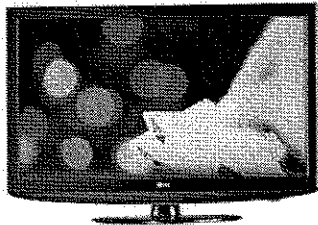

List Price: [See Details](#) **\$2,199.00**  
Price: **\$674.14**  
Shipping: **\$29.61**

**Total Price: \$703.75**

Ships from and sold by [BeachAudio](#)  
[What's this?](#)

**In Stock: Usually ships in 1 to 2 business days.**

[Seller Return Policy](#)

[Write a Review](#)

See more in [HDTV](#)

Share this Product [more](#)

**SQUARE** **5 Day** **3 Year Warranty \$150**  
guarantee

### Marketplace Buying Choices

[ElectronicaDirect](#)

Price: **\$685.09**  
+ \$30.01 shipping  
**In Stock**

See all 3 New from \$674.14 + \$29.61 shipping  
[What's this?](#)

advertisement



#### 5% CASH BACK

Get 5% cash back in popular rotating categories and a full 1% cash back everywhere else. Plus save with a 0% Intro APR and no annual fee.

### Sponsored Links



**Computer on Sale**  
Find and Compare prices on computer on sale at Smarter.com.  
[www.smarter.com](#)



**HP Laptops**  
Select Models Start at \$529.99. Get Free Shipping. Order Online Now.  
[www.hpshopping.com](#)

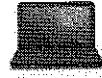

**HP Computers**  
HP is the Top Computer Provider in The U.S. Find Out Why at HP.com!  
[www.hp.com](#)



**PC Advice from Windows**  
Our Online Guide Will Teach You PC Basics & Recommend A PC For You.  
[Microsoft.com/PC-Scout](#)

[more](#)

### Product Summary

Manufacturer: [LG Electronics](#)

Mfg Part#: 32LH250H

UPC: 00719192176157

Buy.com Sku: 212324957

Item#:

Buy.com Sales Rank: 90977

See more in [HDTV](#)

#### Need Help?

Order by Phone **1-800-800-0800**

### Features

- \* RMS Output Power: 20 W
- \* Speakers: Yes
- \* Sound System: Surround
- \* Number of HDMI: 2
- \* VGA: Yes

advertisement







* HDMI	Yes
* Composite Video	Yes
* USB	Yes
* Component Video	Yes
* Manufacturer	LG Electronics
* Manufacturer Website Address	www.lge.com
* Product Model	32LH250H
* Product Type	LCD TV
* Product Name	32LH250H LCD TV
* Manufacturer Part Number	32LH250H
* Green Compliance Certificate/Authority	RoHS
* Package Contents	<ul style="list-style-type: none"> <li>• 32LH250H LCD TV</li> <li>• Remote Control</li> <li>• Security Screws</li> </ul>
* Green Compliance	Yes
* Color	Glossy Black Cabinet
* Dimensions	20.70" Height x 31.60" Width x 4.20" Depth
* Weight	25 lb
* Vertical Viewing Angle	178°
* Screen Size	32"
* Maximum Response Time	5 ms
* Aspect Ratio	16:9
* Horizontal Viewing Angle	178°
* Features	Closed Caption Auto Program Channel Labeling Favorite Channel Selection Auto-off Flashback
* Maximum Resolution	1366 x 768
* Digital Tuner	ATSC
* Video Signal Standard	HD TV 1080p
* Comb Filter	3D Y/C
* Analog Tuner	NTSC
* Brightness	500 Nit
* Standard Warranty	2 Year Limited

**Tech Specs**

* Speakers	Yes
* Sound System	Surround
* RMS Output Power	20 W
* Composite Video	Yes
* USB	Yes
* Component Video	Yes
* Number of HDMI	2
* VGA	Yes
* HDMI	Yes
* Product Model	32LH250H
* Product Type	LCD TV
* Product Name	32LH250H LCD TV
* Manufacturer Part Number	32LH250H
* Brand Name	LG
* Manufacturer	LG Electronics
* Manufacturer Website Address	www.lge.com
* Green Compliance Certificate/Authority	RoHS
* Package Contents	<ul style="list-style-type: none"> <li>• 32LH250H LCD TV</li> <li>• Remote Control</li> <li>• Security Screws</li> </ul>
* Green Compliance	Yes
* Weight	25 lb
* Color	Glossy Black
* Maximum Response Time	5 ms
* Aspect Ratio	16:9
* Horizontal Viewing Angle	178°
* Features	Closed Caption Auto Program Channel Labeling Favorite Channel Selection Auto-off Flashback
* Vertical Viewing Angle	178°
* Screen Size	32"
* Maximum Resolution	1366 x 768

- Digital Tuner ATSC
- Video Signal Standard HD TV 1080p
- Comb Filter 3D Y/C
- Analog Tuner NTSC
- Brightness 500 Nit
- Standard Warranty 2 Year Limited

**Related Videos**

-  [CyberPower Systems CP1000...](#)
-  [HP DM3 Series Laptop](#)
-  [Samsung N150 Netbook](#)
-  [Kingston DataTraveler 500...](#)
-  [Kingston DataTraveler Vau...](#)



**BillMeLater**  
**Buy Now, No Payments for 6 Months!**  
On orders over \$250. Subject to Credit Approval. [Details](#)

**Product Q&A:**

(0 Questions • 0 Answers)

[Q&A HOME](#) | [Browse Q&A](#) | [Search Q&A](#)

Be the first user to ask a question.





[Ask a New Question](#)

[Policies & Guidelines](#)

advertisement

**Add a line \$5** for as low as **\$5**/mo.  
 T-Mobile® Family Talk plans with 2 lines starting at \$49.99/mo. [Learn more](#)

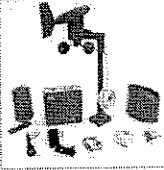
**Your Recently Viewed Items:**

-  [ROXY Shake It Up Womens Romper](#)
-  [SOG B31 Paratool \(Black\)](#)
-  [Thermor IN951 NG TV Home Weather Station](#)
-  [Kensington Mini Battery Pack and Charger for iPhone and iPod](#)

[Clear your recently viewed items](#)

[Back to top](#)

**T-Mobile® Family Talk Plans with 2 lines** starting at \$49.99/mo. **Add a line \$5** for as low as **\$5**/mo. [Learn more](#)

**Top Searched Keywords**

[15.4 laptop](#) [19 lcd monitors](#) [22 LCD Monitor](#) [22 LCD Monitor](#) [LCD Monitor](#) [NAS hard drive](#)

[all in one computers](#) [cable modem](#) [cd dvd drive](#) [dell smb](#) [dell smb laptop](#)  
[desktop computers](#) [desktop memory](#) [firewire external hard drive](#) [flash mp3](#)  
[hard drive enclosure](#) [inkjet multifunction](#) [keyboards](#) [laptop+memory](#) [mice](#) [microsd](#)  
[mouse keyboard combos](#) [netbook](#) [network hard drive](#) [nvidia geforce video cards](#)  
[portable external hard drive](#) [refurbished](#) [refurbished computers](#) [shredder](#)  
[solid state drive](#) [speaker system](#) [speakers](#) [ultra portable computers](#) [usb hard drive](#) [webcams](#)

### Suggestion Box

Every voice counts, so stand up and be heard! Your opinion is important to us. If you have spotted a typo, discovered an incorrect price, or encountered a technical issue on this page, we want to hear about it. Thanks again for your feedback, and happy shopping! **Please note:** we are unable to reply directly to suggestions.

[Submit](#) For additional information, [click here](#) to visit our Help Center.

#### Quick Help

[Forgot Password?](#)  
[Redeem or Buy Gift Certificate](#)  
[Low Price Guarantee](#)  
[Help Center](#)  
[Company Info](#)  
[Customer Service](#)

#### My Account

[Return a Product](#)  
[Login/Register](#)  
[My Cart](#)  
[Order Status](#)  
[Wishlist](#)  
[Track your Order](#)

#### What are you looking for?

[BuyTV](#)  
[Careers@Buy.com](#)  
[Advertising](#)  
[Become an Affiliate](#)  



#### Country

 [Buy.com Canada](#)  
 [Buy.com France](#)  
 [Buy.com Germany](#)  
 [Buy.com Italy](#)  
 [Buy.com Spain](#)  
 [Buy.com United Kingdom](#)

[Terms of Use](#) [Copyright 1997-2010 Buy.com Inc., All rights reserved.](#) [Buy.com Privacy Policy](#)

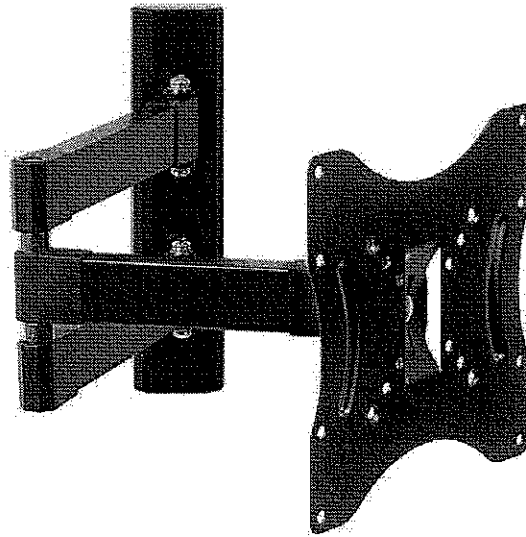

# VideoSecu ML 520B



Specialized in high-quality, well-designed mounting solutions, VideoSecu supplies easy-installed mount at cost-effective prices. The black ML520B wall mount bracket fits 23 26 27 32 37 inch LCD LED flat panel screen TV which has VESA200x200 or 200x100 pattern. Of classic black finish, this mount is compatible with most ambience, sitting rooms, conference rooms, merchandising displays, hotels or anywhere else. It features heavy duty steel structure together with lightness and easy installation. Multi-directional adjustable tilting, swivel, swing, and extending for optimal viewing make it absolutely the best choice for you. This product is black finish.

## Features

- Adjustable tilt of 15 degrees up or down and up to 180 degrees of swivel
- Black Finish
- Fits most 23 26 27 32 37 inch and some up to 42 inch (check VESA and weight) LCD LED flat panel screen TVs
- Fits screens VESA 50x50/75x75/100x100/200x200/200x100mm (2 inx2 in/3 inx3 in/4 inx4 in/8 inx8 in/8 inx4 in) compliant
- Load capacity up to 66 lbs
- Long extension up to 20 in from wall
- Maximum flexibility for installing and viewing LCD LED TV displays
- Multi-directional adjustment tilts, swivels, swings, and extends
- Nesting arm design allows display to be folded parallel to the wall
- Single stud mounting
- Solid Heavy-gauge steel construction



## APTMMB Tilt Wall Mount

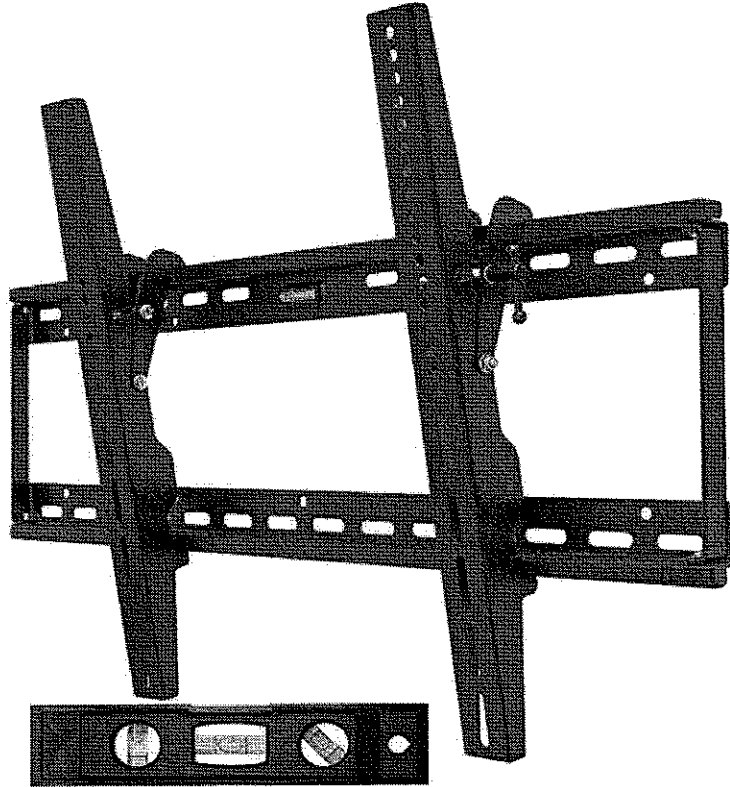

The Cheetah Mounts APTMMB Tilt Wall Mount offers a 0-15 degrees of tilt while maintaining a slim 1.9" profile in the flat position. Weight Capacity 160lbs Supports hole patterns up to 28" (711mm) wide by 19" (483mm) tall. The universal design fits virtually any 32-55" Plasma or LCD TV, including all of the top brands such as Sony, Panasonic, Pioneer, Samsung, etc. A 6" magnetic bubble level is included as a free accessory. Additionally, the wall plate includes a built in bubble level. Mounting hardware is included.

### Features

- Universal Design Fits Virtually Any 32-55" Display
- 0-15 Degree Tilt Adjustment,
- 1.9" Profile
- Free 6" Magnetic Bubble Level
- Included
- Professional Black Powder Coat Finish
- Second Built-in Bubble Level in Wall Plate

RFQ No. DNNR 210184

STATE OF WEST VIRGINIA  
Purchasing Division

**PURCHASING AFFIDAVIT**

**West Virginia Code §5A-3-10a states:** No contract or renewal of any contract may be awarded by the state or any of its political subdivisions to any vendor or prospective vendor when the vendor or prospective vendor or a related party to the vendor or prospective vendor is a debtor and the debt owed is an amount greater than one thousand dollars in the aggregate.

**DEFINITIONS:**

"Debt" means any assessment, premium, penalty, fine, tax or other amount of money owed to the state or any of its political subdivisions because of a judgment, fine, permit violation, license assessment, defaulted workers' compensation premium, penalty or other assessment presently delinquent or due and required to be paid to the state or any of its political subdivisions, including any interest or additional penalties accrued thereon

"Debtor" means any individual, corporation, partnership, association, limited liability company or any other form or business association owing a debt to the state or any of its political subdivisions. "Political subdivision" means any county commission; municipality; county board of education; any instrumentality established by a county or municipality; any separate corporation or instrumentality established by one or more counties or municipalities, as permitted by law; or any public body charged by law with the performance of a government function or whose jurisdiction is coextensive with one or more counties or municipalities "Related party" means a party, whether an individual, corporation, partnership, association, limited liability company or any other form or business association or other entity whatsoever, related to any vendor by blood, marriage, ownership or contract through which the party has a relationship of ownership or other interest with the vendor so that the party will actually or by effect receive or control a portion of the benefit, profit or other consideration from performance of a vendor contract with the party receiving an amount that meets or exceed five percent of the total contract amount.

**EXCEPTION:** The prohibition of this section does not apply where a vendor has contested any tax administered pursuant to chapter eleven of this code, workers' compensation premium, permit fee or environmental fee or assessment and the matter has not become final or where the vendor has entered into a payment plan or agreement and the vendor is not in default of any of the provisions of such plan or agreement.

Under penalty of law for false swearing (*West Virginia Code §61-5-3*), it is hereby certified that the vendor affirms and acknowledges the information in this affidavit and is in compliance with the requirements as stated

**WITNESS THE FOLLOWING SIGNATURE**

Vendor's Name: Long's Security Camera System LLC

Authorized Signature: *Alan E. Long* Date: 4-27-10

State of West Virginia

County of Marshall, to-wit:

Taken, subscribed, and sworn to before me this 27<sup>th</sup> day of April, 2010

My Commission expires 01/03, 2011

AFFIX SEAL HERE

NOTARY PUBLIC

*Carolyn L. Cole*

