



State of West Virginia
 Department of Administration
 Purchasing Division
 2019 Washington Street East
 Post Office Box 50130
 Charleston, WV 25305-0130

Request for Quotation

RFQ NUMBER
DNR210080

PAGE
1

ADDRESS CORRESPONDENCE TO ATTENTION OF
FRANK WHITTAKER 804-558-2316

RFQ COPY
 TYPE NAME/ADDRESS HERE

VENDOR

A.J. SMITH, INC.
 DBA CAPITAL BUILDERS
 4008 5TH STREET ROAD
 HUNTINGTON WV 25701

SHIP TO

DIVISION OF NATURAL RESOURCES
 PARKS & RECREATION SECTION
 324 4TH AVENUE
 SOUTH CHARLESTON, WV
 25303-1228 304-558-3397

DATE PRINTED	TERMS OF SALE	SHIP VIA	F.O.B.	FREIGHT TERMS
12/17/2009				

BID OPENING DATE: 01/14/2010 BID OPENING TIME 01:30PM

LINE	QUANTITY	UOP	CAT NO	ITEM NUMBER	UNIT PRICE	AMOUNT
0001	1	LS		990-22	69,500. ⁰⁰	69,500. ⁰⁰
CCTV, SECURITY, AND ACCESS CONTROL SYSTEM THE WEST VIRGINIA PURCHASING DIVISION, FOR THE AGENCY, THE WEST VIRGINIA DIVISION OF NATURAL RESOURCES IS SOLICITATION BIDS TO FURNISH AND INSTALL A CLOSED CIRCUIT TELEVISION (CCTV) SYSTEM, ACCESS CONTROL, AND INTRUSION DETECTION FOR THE CHEIF LOGAN RECREATION CENTER, LOGAN WV. MANDATORY PRE-BID A MANDATORY PRE-BID WILL BE HELD ON 12/29/09 @ 1:30 PM AT THE CHEIF LOGAN RECREATION CENTER, LOGAN, WV. ALL INTERESTED PARTIES ARE REQUIRED TO ATTEND THIS MEETING. FAILURE TO ATTEND THE MANDATORY PRE-BID SHALL RESULT I DISQUALIFICATION OF THE BID. NO ONE PERSON MAY REPRESENT MORE THAN ONE BIDDER. AN ATTENDANCE SHEET WILL BE MADE AVAILABLE FOR ALL POTENTIAL BIDDERS TO COMPLETE. THIS WILL SERVE AS THE OFFICIAL DOCUMENT VERIFYING ATTENDANCE AT THE MANDATOR PRE-BID. FAILURE TO PROVIDE YOUR COMPANY AND REPRESENTATIVE NAME ON THE ATTENDANCE SHEET WILL RESULT IN DISQUALIFICATION OF THE BID. THE STATE WILL NOT ACCEPT ANY OTHER DOCUMENTATION TO VERIFY ATTENDANCE. THE BIDDER IS RESPONSIBLE FOR ENSURING THEY HAVE COMPLETED THE INFORMATION REQUIRED ON THE ATTENDANCE SHEET. THE PURCHASING DIVISION AND THE STATE AGENCY WILL NOT ASSUME ANY RESPONSIBILITY FOR A BIDDER-S FAILURE TO COMPLETE THE PRE-BID ATTENDANCE SHEET. IN ADDITION, WE REQUEST THAT ALL POTENTIAL BIDDERS INCLUDE THEIR E-MAIL ADDRESS AND FAX NUMBER.						

RECEIVED

2010 JAN 14 PM 1:05

WV PURCHASING DIVISION

SEE REVERSE SIDE FOR TERMS AND CONDITIONS

SIGNATURE <i>B. J. Burgess</i>	TELEPHONE (304) 697-5002	DATE 1/14/2010
TITLE President	FEIN 55-0735961	ADDRESS CHANGES TO BE NOTED ABOVE

WHEN RESPONDING TO RFQ, INSERT NAME AND ADDRESS IN SPACE ABOVE LABELED 'VENDOR'



State of West Virginia
 Department of Administration
 Purchasing Division
 2019 Washington Street East
 Post Office Box 50130
 Charleston, WV 25305-0130

Request for Quotation

RFQ NUMBER
DNR210080

PAGE
2

ADDRESS CORRESPONDENCE TO ATTENTION OF
FRANK WHITTAKER 304-558-2316

VENDOR

RFQ COPY
 TYPE NAME/ADDRESS HERE

A.J. SMITH, INC.
 DBA CAPITAL BUILDERS
 4008 5TH STREET ROAD
 HUNTINGTON, WV 25701

SHIP TO

DIVISION OF NATURAL RESOURCES
 PARKS & RECREATION SECTION
 324 4TH AVENUE
 SOUTH CHARLESTON, WV
 25303-1228 304-558-3397

DATE PRINTED	TERMS OF SALE	SHIP VIA	F.O.B.	FREIGHT TERMS
12/17/2009				

BID OPENING DATE: 01/14/2010 BID OPENING TIME 01:30PM

LINE	QUANTITY	UOP	CAT NO.	ITEM NUMBER	UNIT PRICE	AMOUNT
<p>ALL POTENTIAL BIDDERS ARE REQUESTED TO ARRIVE PRIOR TO THE STARTING TIME FOR THE PRE-BID. BIDDERS WHO ARRIVE LATE, BUT PRIOR TO THE DISMISSAL OF THE TECHNICAL PORTION OF THE PRE-BID WILL BE PERMITTED TO SIGN IN. BIDDERS WHO ARRIVE AFTER CONCLUSION OF THE TECHNICAL PORTION OF THE PRE-BID, BUT DURING ANY SUBSEQUENT PART OF THE PRE-BID WILL NOT BE PERMITTED TO SIGN THE ATTENDANCE SHEET.</p> <p>ALL TECHNICAL QUESTIONS MUST BE SUBMITTED IN WRITING TO FRANK WHITTAKER IN THE PURCHASING DIVISION VIA EMAIL AT FRANK.M.WHITTAKER@WV.GOV OR VIA FAX AT 304-558-4115 DEADLINE FOR TECHNICAL QUESTIONS IS 01/05/2010 @ 4:00 PM ALL TECHNICAL QUESTIONS WILL BE ADDRESSED BY ADDENDUM AFTER THE DEADLINE.</p> <p>EXHIBIT 5</p> <p>WEST VIRGINIA CODE 21-1D-5 PROVIDES THAT: ANY SOLICITATION FOR A PUBLIC IMPROVEMENT CONSTRUCTION CONTRACT REQUIRES EACH VENDOR THAT SUBMITS A BID FOR THE WORK TO SUBMIT AT THE SAME TIME AN AFFIDAVIT OF COMPLIANCE WITH THE BID. THE ENCLOSED DRUG-FREE WORKPLACE AFFIDAVIT MUST BE SIGNED AND SUBMITTED WITH THE BID AS EVIDENCE OF THE VENDOR'S COMPLIANCE WITH THE PROVISIONS OF ARTICLE 1D, CHAPTER 21 OF THE WEST VIRGINIA CODE. FAILURE TO SUBMIT THE SIGNED DRUG-FREE WORKPLACE AFFIDAVIT WITH THE BID SHALL RESULT IN DISQUALIFICATION OF SUCH BID.</p> <p>NOTICE TO PROCEED: THIS CONTRACT IS TO BE PERFORMED WITHIN 30 CALENDAR DAYS AFTER THE NOTICE TO PROCEED IS RECEIVED. UNLESS OTHERWISE SPECIFIED, THE FULLY EXECUTED PURCHASE ORDER WILL BE CONSIDERED NOTICE TO PROCEED.</p> <p>CANCELLATION: THE DIRECTOR OF PURCHASING RESERVES THE</p>						

SEE REVERSE SIDE FOR TERMS AND CONDITIONS

SIGNATURE <i>B. J. Dwyer</i>	TELEPHONE (304) 697-5002	DATE 1/14/2010
TITLE President	FEIN 55-0735961	ADDRESS CHANGES TO BE NOTED ABOVE

WHEN RESPONDING TO RFQ, INSERT NAME AND ADDRESS IN SPACE ABOVE LABELED 'VENDOR'



State of West Virginia
 Department of Administration
 Purchasing Division
 2019 Washington Street East
 Post Office Box 50130
 Charleston, WV 25305-0130

Request for Quotation

RFQ NUMBER
 DNR210080

PAGE
 3

ADDRESS CORRESPONDENCE TO ATTENTION OF:
 FRANK WHITTAKER
 304-558-2316

RFQ COPY
 TYPE NAME/ADDRESS HERE

A.J. SMITH, INC.
 DBA CAPITAL BUILDERS
 4008 5TH STREET ROAD
 HUNTINGTON WV 25701

DIVISION OF NATURAL RESOURCES
 PARKS & RECREATION SECTION

324 4TH AVENUE
 SOUTH CHARLESTON, WV
 25303-1228 304-558-3397

DATE PRINTED 12/17/2009	TERMS OF SALE	SHIP VIA	F.O.B.	FREIGHT TERMS
----------------------------	---------------	----------	--------	---------------

BID OPENING DATE: 01/14/2010 BID OPENING TIME 01:30PM

LINE	QUANTITY	UOP	CAT. NO.	ITEM NUMBER	UNIT PRICE	AMOUNT
<p>RIGHT TO CANCEL THIS CONTRACT IMMEDIATELY UPON WRITTEN NOTICE TO THE VENDOR IF THE MATERIALS OR WORKMANSHIP SUPPLIED ARE OF AN INFERIOR QUALITY OR DO NOT CONFORM WITH THE SPECIFICATIONS OF THE BID AND CONTRACT HERE IN.</p> <p>WAGE RATES: THE CONTRACTOR OR SUBCONTRACTOR SHALL PAY THE HIGHER OF THE U.S. DEPARTMENT OF LABOR MINIMUM WAGE RATES AS ESTABLISHED FOR LOGAN COUNTY, PURSUANT TO WEST VIRGINIA CODE 21-5A, ET, SEQ. (PREVAILING WAGE RATES APPLY TO THIS PROJECT)</p> <p>ARBITRATION: ANY REFERENCES MADE TO ARBITRATION OR INTEREST FOR PAYMENTS DUE (EXCEPT FOR ANY INTEREST REQUIRED BY STATE LAW) CONTAINED IN THIS CONTRACT OR IN ANY AMERICAN INSTITUTE OF ARCHITECTS DOCUMENTS PERTAINING TO THIS CONTRACT ARE HEREBY DELETED.</p> <p>WORKERS' COMPENSATION: VENDOR IS REQUIRED TO PROVIDE A CERTIFICATE FROM WORKERS' COMPENSATION IF SUCCESSFUL.</p> <p>ALL OF THE ITEMS CHECKED BELOW WILL BE A REQUIREMENT OF THIS CONTRACT:</p> <p>(XX) INSURANCE: SUCCESSFUL VENDOR SHALL FURNISH PROOF OF COMMERCIAL GENERAL LIABILITY INSURANCE PRIOR TO ISSUANCE OF CONTRACT. UNLESS OTHERWISE SPECIFIED IN THE BID DOCUMENTS, THE MINIMUM AMOUNT OF INSURANCE COVERAGE REQUIRED IS \$250,000.</p> <p>() BUILDERS RISK INSURANCE: SUCCESSFUL VENDOR SHALL FURNISH PROOF OF BUILDERS RISK - ALL RISK INSURANCE IN AN AMOUNT EQUAL TO 100% OF THE AMOUNT OF THE CONTRACT.</p> <p>(XX) BONDS: FIVE PERCENT (5%) OF THE TOTAL AMOUNT OF THE BID PAYABLE TO THE STATE OF WEST VIRGINIA, SHALL B</p>						

SIGNATURE <i>B. J. Burgess</i>		TELEPHONE (304) 697-5002	DATE 1/14/2010
TITLE President	FEIN 55-0735961	ADDRESS CHANGES TO BE NOTED ABOVE	

WHEN RESPONDING TO RFQ, INSERT NAME AND ADDRESS IN SPACE ABOVE LABELED 'VENDOR'



State of West Virginia
 Department of Administration
 Purchasing Division
 2019 Washington Street East
 Post Office Box 50130
 Charleston, WV 25305-0130

Request for Quotation

RFQ NUMBER
 DNR210080

PAGE
 4

ADDRESS CORRESPONDENCE TO ATTENTION OF
 FRANK WHITTAKER
 304-558-2316

RFQ COPY
 TYPE NAME/ADDRESS HERE
 A.J. SMITH, INC.
 DBA CAPITAL BUILDERS
 4008 5TH STREET ROAD
 HUNTINGTON WV 25701

DIVISION OF NATURAL RESOURCES
 PARKS & RECREATION SECTION
 324 4TH AVENUE
 SOUTH CHARLESTON, WV
 25303-1228 304-558-3397

DATE PRINTED	TERMS OF SALE	SHIP VIA	F.O.B.	FREIGHT TERMS
12/17/2009				

BID OPENING DATE: 01/14/2010 BID OPENING TIME 01:30PM

LINE	QUANTITY	UOP	CAT NO.	ITEM NUMBER	UNIT PRICE	AMOUNT
<p>SUBMITTED WITH EACH BID AS A BID BOND. THE SUCCESSFUL BIDDER SHALL ALSO FURNISH A PERFORMANCE BOND AND LABOR/MATERIAL BOND FOR 100% OF THE AMOUNT OF THE CONTRACT. BONDS MAY BE PROVIDED IN THE FORM OF A CERTIFIED CHECK, IRREVOCABLE LETTER OF CREDIT, OR BOND FURNISHED BY A SOLVENT SURETY COMPANY AUTHORIZED TO DO BUSINESS IN THE STATE OF WEST VIRGINIA. A LETTER OF CREDIT SUBMITTED IN LIEU OF A BOND WILL ONLY BE ALLOWED FOR PROJECTS UNDER \$100,000. PERSONAL OR BUSINESS CHECKS ARE NOT ACCEPTABLE IN LIEU OF THE 5% BID BOND, PERFORMANCE BOND, OR LABOR AND MATERIAL BOND.</p> <p>() MAINTENANCE BOND: A TWO (2) YEAR MAINTENANCE BOND COVERING THE ROOFING SYSTEM WILL BE A REQUIREMENT OF THE SUCCESSFUL VENDOR.</p> <p>REV. 11/00</p> <p>EXHIBIT 7</p> <p>DOMESTIC ALUMINUM, GLASS & STEEL IN PUBLIC WORKS PROJECTS</p> <p>IN ACCORDANCE WITH WEST VIRGINIA CODE 5-19-1 ET., SEQ., EVERY CONTRACT FOR CONSTRUCTION, RECONSTRUCTION, ALTERATION, REPAIR, IMPROVEMENT OR MAINTENANCE OF PUBLIC WORKS, WHERE THE COST IS MORE THAN \$50,000 AND, IN THE CASE OF STEEL ONLY, WHERE THE COST OF STEEL IS MORE THAN \$50,000 OR WHERE MORE THAN 10,000 POUNDS OF STEEL ARE REQUIRED, THE STATE WILL ACCEPT ONLY ALUMINUM GLASS, OR STEEL PRODUCTS PRODUCED IN THE UNITED STATES. IN ADDITION, ITEMS OF MACHINERY OR EQUIPMENT PURCHASED FOR USE AT THE SITE OF PUBLIC WORKS SHALL BE MADE OF DOMESTIC ALUMINUM, GLASS OR STEEL, UNLESS THE COST OF THE PRODUCT IS LESS THAN \$50,000 OR LESS THAN 10,000</p>						

SEE REVERSE SIDE FOR TERMS AND CONDITIONS

SIGNATURE <i>B. J. Buyess</i>	TELEPHONE (304) 697-5002	DATE 1/14/2010
TITLE President	FEIN 55-0735961	ADDRESS CHANGES TO BE NOTED ABOVE

WHEN RESPONDING TO RFQ, INSERT NAME AND ADDRESS IN SPACE ABOVE LABELED 'VENDOR'



State of West Virginia
 Department of Administration
 Purchasing Division
 2019 Washington Street East
 Post Office Box 50130
 Charleston, WV 25305-0130

Request for Quotation

RFQ NUMBER
 DNR210080

PAGE
 5

ADDRESS CORRESPONDENCE TO ATTENTION OF
 FRANK WHITTAKER
 304-558-2316

RFQ COPY
 TYPE NAME/ADDRESS HERE
 A.J. SMITH, INC.
 DBA CAPITAL BUILDERS
 4008 5TH STREET ROAD
 HUNTINGTON WV 25701

DIVISION OF NATURAL RESOURCES
 PARKS & RECREATION SECTION
 324 4TH AVENUE
 SOUTH CHARLESTON, WV
 25303-1228 304-558-3397

DATE PRINTED	TERMS OF SALE	SHIP VIA	F.O.B.	FREIGHT TERMS
12/17/2009				

BID OPENING DATE: 01/14/2010 BID OPENING TIME 01:30PM

LINE	QUANTITY	UOP	CAT. NO.	ITEM NUMBER	UNIT PRICE	AMOUNT
<p>POUNDS OF STEEL ARE USED IN PUBLIC WORKS PROJECTS.</p> <p>FOREIGN MADE ALUMINUM, GLASS OR STEEL PRODUCTS MAY BE ACCEPTED ONLY IF THE COST OF DOMESTIC PRODUCTS IS FOUND TO BE UNREASONABLE. SUCH COST IS UNREASONABLE IF IT IS 20% OR MORE HIGHER THAN THE BID PRICE FOR FOREIGN MADE PRODUCTS. IF THE DOMESTIC ALUMINUM, GLASS OR STEEL PRODUCTS TO BE SUPPLIED OR PRODUCED IN A "SUBSTANTIAL LABOR SURPLUS AREA", AS DEFINED BY THE UNITED STATES DEPARTMENT OF LABOR, FOREIGN PRODUCTS MAY BE SUPPLIED ONLY IF DOMESTIC PRODUCTS ARE 30% OR MORE HIGHER IN PRICE THAN THE FOREIGN MADE PRODUCTS.</p> <p>IF, PRIOR TO THE AWARD OF A CONTRACT UNDER THE ABOVE PROVISIONS, THE SPENDING OFFICER OF THE SPENDING UNIT DETERMINES THAT THERE EXISTS A BID FOR LIKE FOREIGN ALUMINUM, GLASS OR STEEL THAT IS REASONABLE AND LOWER THAN THE LOWEST BID DOMESTIC PRODUCTS, THE SPENDING OFFICE MAY REQUEST, IN WRITING, A REEVALUATION AND REDUCTION IN THE LOWEST BID FOR SUCH DOMESTIC PRODUCTS. ALL VENDORS MUST INDICATE IN THEIR BID IF THEY ARE SUPPLYING FOREIGN ALUMINUM, GLASS OR STEEL.</p> <p>REV. 3/88</p> <p>EXHIBIT 9</p> <p>NOTICE FOR ISSUANCE & ACKNOWLEDGEMENT OF CONSTRUCTION PROJECT ADDENDA</p> <p>THE ARCHITECT/ENGINEER AND/OR AGENCY SHALL BE REQUIRED TO ABIDE BY THE FOLLOWING SCHEDULE IN ISSUING CONSTRUCTION PROJECT ADDENDA FOR STATE AGENCIES:</p> <p>(1) THE ARCHITECT/ENGINEER SHALL PREPARE THE ADDENDUM</p>						

SEE REVERSE SIDE FOR TERMS AND CONDITIONS

SIGNATURE <i>B. J. Burgess</i>	TELEPHONE (304) 697-5002	DATE 01/14/2010
TITLE PRESIDENT	FEIN 55-0735961	ADDRESS CHANGES TO BE NOTED ABOVE

WHEN RESPONDING TO RFQ, INSERT NAME AND ADDRESS IN SPACE ABOVE LABELED 'VENDOR'



State of West Virginia
 Department of Administration
 Purchasing Division
 2019 Washington Street East
 Post Office Box 50130
 Charleston, WV 25305-0130

Request for Quotation

RFQ NUMBER
DNR210080

PAGE
6

ADDRESS CORRESPONDENCE TO ATTENTION OF:
FRANK WHITTAKER 304-558-2316

VENDOR

RFQ COPY
 TYPE NAME/ADDRESS HERE

A.J. SMITH, INC.
 DBA CAPITAL BUILDERS
 4008 5TH STREET ROAD
 HUNTINGTON WV 25701

SHIP TO

DIVISION OF NATURAL RESOURCES
 PARKS & RECREATION SECTION

324 4TH AVENUE
 SOUTH CHARLESTON, WV
 25303-1228 304-558-3397

DATE PRINTED	TERMS OF SALE	SHIP VIA	F.O.B.	FREIGHT TERMS
12/17/2009				

BID OPENING DATE: 01/14/2010 BID OPENING TIME 01:30PM

LINE	QUANTITY	UOP	CAT. NO.	ITEM NUMBER	UNIT PRICE	AMOUNT
<p>AND A LIST OF ALL PARTIES THAT HAVE PROCURED DRAWINGS AND SPECIFICATIONS FOR THE PROJECT. THE ADDENDUM AND LIST SHALL BE FORWARDED TO THE BUYER IN THE STATE PURCHASING DIVISION. THE ARCHITECT/ENGINEER SHALL ALSO SEND A COPY OF THE ADDENDUM TO THE STATE AGENCY FOR WHICH THE CONTRACT IS ISSUED.</p> <p>(2) THE BUYER SHALL SEND THE ADDENDUM TO ALL INTERESTED PARTIES AND, IF NECESSARY, EXTEND THE BID OPENING DATE. ANY ADDENDUM SHOULD BE RECEIVED BY THE BUYER WITHIN FOURTEEN (14) DAYS PRIOR TO THE BID OPENING DATE.</p> <p>(3) ALL ADDENDA SHOULD BE FORMALLY ACKNOWLEDGED BY ALL BIDDERS AND SUBMITTED TO THE STATE PURCHASING DIVISION. THE SAME RULES AND REGULATIONS THAT APPLY TO THE ORIGINAL BIDDING DOCUMENT SHALL ALSO APPLY TO AN ADDENDUM DOCUMENT. THE ONLY EXCEPTION MAY BE FOR AN ADDENDUM THAT IS ISSUED FOR THE SOLE PURPOSE OF CHANGING A BID OPENING TIME AND/OR DATE.</p> <p>REV. 11/96</p> <p>EXHIBIT 10</p> <p>ADDENDUM ACKNOWLEDGEMENT</p> <p>I HEREBY ACKNOWLEDGE RECEIPT OF THE FOLLOWING CHECKED ADDENDUM(S) AND HAVE MADE THE NECESSARY REVISIONS TO MY PROPOSAL, PLANS AND/OR SPECIFICATION, ETC.</p> <p>ADDENDUM NOS. :</p> <p>NO. 1 X date printed 01/06/2010</p>						

SEE REVERSE SIDE FOR TERMS AND CONDITIONS

SIGNATURE <i>B. J. Burgess</i>	TELEPHONE (304) 697-5002	DATE 1/14/2010
TITLE President	FEIN 55-0735961	ADDRESS CHANGES TO BE NOTED ABOVE

WHEN RESPONDING TO RFQ, INSERT NAME AND ADDRESS IN SPACE ABOVE LABELED 'VENDOR'



State of West Virginia
 Department of Administration
 Purchasing Division
 2019 Washington Street East
 Post Office Box 50130
 Charleston, WV 25305-0130

Request for Quotation

RFQ NUMBER
DNR210080

PAGE
7

ADDRESS CORRESPONDENCE TO ATTENTION OF:
FRANK WHITTAKER 304-558-2316

VENDOR

RFQ COPY
 TYPE NAME/ADDRESS HERE

A.J. SMITH, INC.
 DBA CAPITAL BUILDERS
 4008 5TH STREET ROAD
 HUNTINGTON WV 25701

SHIP TO

DIVISION OF NATURAL RESOURCES
 PARKS & RECREATION SECTION

 324 4TH AVENUE
 SOUTH CHARLESTON, WV
 25303-1228 304-558-3397

DATE PRINTED	TERMS OF SALE	SHIP VIA	F.O.B.	FREIGHT TERMS
12/17/2009				

BID OPENING DATE: 01/14/2010 BID OPENING TIME 01:30PM

LINE	QUANTITY	UOP	CAT NO.	ITEM NUMBER	UNIT PRICE	AMOUNT
NO. 2						
NO. 3						
NO. 4						
NO. 5						
<p>I UNDERSTAND THAT FAILURE TO CONFIRM THE RECEIPT OF THE ADDENDUM(S) MAY BE CAUSE FOR REJECTION OF THE BIDS.</p> <p>VENDOR MUST CLEARLY UNDERSTAND THAT ANY VERBAL REPRESENTATION MADE OR ASSUMED TO BE MADE DURING ANY ORAL DISCUSSION HELD BETWEEN VENDOR'S REPRESENTATIVES AND ANY STATE PERSONNEL IS NOT BINDING. ONLY THE INFORMATION ISSUED IN WRITING AND ADDED TO THE SPECIFICATIONS BY AN OFFICIAL ADDENDUM IS BINDING.</p> <p><i>S. J. Burgess</i> SIGNATURE</p> <p>A.J. SMITH, INC. DBA CAPITAL BUILDERS..... COMPANY</p> <p>JANUARY, 14, 2010 DATE</p> <p>REV. 11/96</p> <p>CONTRACTORS LICENSE</p> <p>WEST VIRGINIA STATE CODE 21-11-2 REQUIRES THAT ALL PERSONS DESIRING TO PERFORM CONTRACTING WORK IN THIS STATE MUST BE LICENSED. THE WEST VIRGINIA CONTRACTORS LICENSING BOARD IS EMPOWERED TO ISSUE THE CONTRACTORS LICENSE. APPLICATIONS FOR A CONTRACTORS LICENSE MAY B</p>						

SEE REVERSE SIDE FOR TERMS AND CONDITIONS

SIGNATURE <i>S. J. Burgess</i>	TELEPHONE (304) 697-5002	DATE 01/14/2010
TITLE President	FEIN 55-0735961	ADDRESS CHANGES TO BE NOTED ABOVE

WHEN RESPONDING TO RFQ, INSERT NAME AND ADDRESS IN SPACE ABOVE LABELED 'VENDOR'



State of West Virginia
 Department of Administration
 Purchasing Division
 2019 Washington Street East
 Post Office Box 50130
 Charleston, WV 25305-0130

Request for Quotation

RFQ NUMBER
 DNR210080

PAGE
 8

ADDRESS CORRESPONDENCE TO ATTENTION OF
 FRANK WHITTAKER
 304-558-2316

RFQ COPY
 TYPE NAME/ADDRESS HERE

A.J. SMITH, INC.
 DBA CAPITAL BUILDERS
 4008 5TH STREET ROAD
 HUNTINGTON WV 25701

DIVISION OF NATURAL RESOURCES
 PARKS & RECREATION SECTION

324 4TH AVENUE
 SOUTH CHARLESTON, WV
 25303-1228 304-558-3397

DATE PRINTED	TERMS OF SALE	SHIP VIA	F.O.B.	FREIGHT TERMS
12/17/2009				

BID OPENING DATE: 01/14/2010 BID OPENING TIME 01:30PM

LINE	QUANTITY	UOP	CAT. NO.	ITEM NUMBER	UNIT PRICE	AMOUNT
<p>MADE BY CONTACTING THE WEST VIRGINIA DIVISION OF LABOR CAPITOL COMPLEX, BUILDING 3, ROOM 319, CHARLESTON, WV 25305. TELEPHONE: (304) 558-7890.</p> <p>WEST VIRGINIA STATE CODE 21-11-11 REQUIRES ANY PROSPECTIVE BIDDER TO INCLUDE THE CONTRACTORS LICENSE NUMBER ON THEIR BID.</p> <p>BIDDER TO COMPLETE:</p> <p>CONTRACTORS NAME: A.J. SMITH, INC., DBA CAPITAL BUILDERS.....</p> <p>CONTRACTORS LICENSE NO.: WV032728.....</p> <p>THE SUCCESSFUL BIDDER WILL BE REQUIRED TO FURNISH A COPY OF THEIR CONTRACTORS LICENSE PRIOR TO ISSUANCE OF A PURCHASE ORDER/CONTRACT</p> <p>APPLICABLE LAW</p> <p>THE WEST VIRGINIA STATE CODE, PURCHASING DIVISION RULES AND REGULATIONS, AND THE INFORMATION PROVIDED IN THE "REQUEST FOR QUOTATION" ISSUED BY THE PURCHASING DIVISION IS THE SOLE AUTHORITY GOVERNING THIS PROCUREMENT.</p> <p>ANY INFORMATION PROVIDED IN SPECIFICATION MANUALS, OR ANY OTHER SOURCE, VERBAL OR WRITTEN, WHICH CONTRADICTS OR ALTERS THE INFORMATION PROVIDED FROM THE SOURCES AS DESCRIBED IN THE ABOVE PARAGRAPH IS VOID AND OF NO EFFECT.</p> <p>BANKRUPTCY: IN THE EVENT THE VENDOR/CONTRACTOR FILES FOR BANKRUPTCY PROTECTION, THE STATE MAY DEEM THE CONTRACT NULL AND VOID, AND TERMINATE SUCH CONTRACT WITHOUT FURTHER ORDER.</p>						

SEE REVERSE SIDE FOR TERMS AND CONDITIONS

SIGNATURE <i>B. J. Burgess</i>	TELEPHONE (304) 697-5002	DATE 01/14/2010
TITLE President	FEIN 55-0735961	ADDRESS CHANGES TO BE NOTED ABOVE

WHEN RESPONDING TO RFQ, INSERT NAME AND ADDRESS IN SPACE ABOVE LABELED 'VENDOR'



State of West Virginia
 Department of Administration
 Purchasing Division
 2019 Washington Street East
 Post Office Box 50130
 Charleston, WV 25305-0130

Request for Quotation

RFQ NUMBER
DNR210080

PAGE
9

ADDRESS CORRESPONDENCE TO ATTENTION OF
FRANK WHITTAKER 304-558-2316

VENDOR

RFQ COPY
 TYPE NAME/ADDRESS HERE

A.J. SMITH, INC.
 DBA CAPITAL BUILDERS
 4008 5TH STREET ROAD
 HUNTINGTON WV 25701

SHIP TO

DIVISION OF NATURAL RESOURCES
 PARKS & RECREATION SECTION
 324 4TH AVENUE
 SOUTH CHARLESTON, WV
 25303-1228 304-558-3397

DATE PRINTED	TERMS OF SALE	SHIP VIA	F.O.B.	FREIGHT TERMS
12/17/2009				

BID OPENING DATE: 01/14/2010 BID OPENING TIME 01:30PM

LINE	QUANTITY	UOP	CAT. NO	ITEM NUMBER	UNIT PRICE	AMOUNT
REV. 5/2009 NOTICE A SIGNED BID MUST BE SUBMITTED TO: DEPARTMENT OF ADMINISTRATION PURCHASING DIVISION BUILDING 15 2019 WASHINGTON STREET, EAST CHARLESTON, WV 25305-0130 THE BID SHOULD CONTAIN THIS INFORMATION ON THE FACE OF THE ENVELOPE OR THE BID MAY NOT BE CONSIDERED: SEALED BID BUYER: 44 REQ. NO.: DNR210080 BID OPENING DATE: 01/14/2010 BID OPENING TIME: 1:30 PM PLEASE PROVIDE A FAX NUMBER IN CASE IT IS NECESSARY TO CONTACT YOU REGARDING YOUR BID: (304) 697-5004 PLEASE PRINT OR TYPE NAME OF PERSON TO CONTACT CONCERNING THIS QUOTE:						

SEE REVERSE SIDE FOR TERMS AND CONDITIONS

SIGNATURE	TELEPHONE	DATE
<i>B. J. Guyess</i>	(304) 697-5002	01/14/2010
TITLE	FERN	ADDRESS CHANGES TO BE NOTED ABOVE
President	55-0735961	

WHEN RESPONDING TO RFQ, INSERT NAME AND ADDRESS IN SPACE ABOVE LABELED 'VENDOR'



State of West Virginia
 Department of Administration
 Purchasing Division
 2019 Washington Street East
 Post Office Box 50130
 Charleston, WV 25305-0130

Request for Quotation

RFQ NUMBER
 DNR210080

PAGE
 10

ADDRESS CORRESPONDENCE TO ATTENTION OF:
 FRANK WHITTAKER
 304-558-2316

RFQ COPY
 TYPE NAME/ADDRESS HERE

A.J. SMITH, INC.
 DBA CAPITAL BUILDERS
 4008 5TH STREET ROAD
 HUNTINGTON WV 25701

DIVISION OF NATURAL RESOURCES
 PARKS & RECREATION SECTION

324 4TH AVENUE
 SOUTH CHARLESTON, WV
 25303-1228 304-558-3397

DATE PRINTED 12/17/2009	TERMS OF SALE	SHIP VIA	F.O.B.	FREIGHT TERMS
----------------------------	---------------	----------	--------	---------------

BID OPENING DATE: 01/14/2010 BID OPENING TIME 01:30PM

LINE	QUANTITY	UOP	CAT NO.	ITEM NUMBER	UNIT PRICE	AMOUNT
B. L. BLOWER						
***** THIS IS THE END OF RFQ DNR210080 ***** TOTAL:						<u>69,500.⁰⁰</u>

SEE REVERSE SIDE FOR TERMS AND CONDITIONS

SIGNATURE <i>B. J. Burgess</i>	TELEPHONE (304) 697-5002	DATE 01/14/2010
TITLE President	FEIN 55-0735961	ADDRESS CHANGES TO BE NOTED ABOVE

WHEN RESPONDING TO RFQ, INSERT NAME AND ADDRESS IN SPACE ABOVE LABELED 'VENDOR'

Chief Logan Recreation Center	INVITATION TO BID
CCTV, Security, and Access Control System	Page 1
Logan County, West Virginia	

The Division of Natural Resources, Parks and Recreation, requests bids to furnish and install Closed Circuit Television (CCTV) system, access control, and intrusion detection for the Chief Logan Recreation Center, Logan County, WV.

Sealed bids will be received until 1:30 p.m. on 01/14/2010 at the WV State Purchasing Division, 2019 Washington Street, East, Capitol Complex, Charleston, WV.

A mandatory Pre-Bid Conference will be held on December 29, 2009 at 1:30 pm at the Site.

No bids will be considered from other than those present at the Pre-Bid Conference.

The bidding documents consist of the Request for Quotations, plans and specifications.

Request for quotations may be obtained by contacting:

Frank Whittaker, Senior Buyer
 Finance and Administration, Purchasing Division
 2019 Washington Street, East
 Charleston, WV 25305
 Telephone: 304-558-2316 Ext. 218

Plans and specifications may be obtained by contacting:

Sherri Goff
 WVDNR, Parks and Recreation Section
 Capitol Complex, Building 3, Room 719
 Charleston, WV 25305
 Telephone: 304-558-2764 Ext. 251

No fee is required for bidding documents.

The bidder understands that to the extent allowed by the West Virginia Code, the Owner reserves the right to waive any informality or irregularity in any Bid, or Bids, and to reject any or all Bids in whole or in part; to reject a bid not accompanied by the required bid security or by other data required by the Bidding Documents; to reject any condition of the bid by the Bidder that is in any way inconsistent with the requirements, terms and conditions of the Bidding Documents; or to reject a bid that is in any way incomplete or irregular.

The Bidder, if successful and awarded the contract, agrees that all work is to be complete within thirty (30) consecutive calendar days following receipt of the Owner's written Notice to Proceed. For each calendar day of delay in achieving completion, the Vendor shall be liable for, and shall pay the Owner liquidated damages in the amount of \$100 per day.

Any work performed or any materials contracted for prior to the receipt of the Owner's written Notice to Proceed, shall be at the Bidder's risk.

INFORMATION FOR BIDDERS

1. Examination of Contract Documents and Site

Each bidder must inform themselves fully of the conditions relating to the construction of the project and the employment of labor thereon. Failure to do so will not relieve a successful bidder of their obligation to furnish all material and labor necessary to carry out the provisions of his contract. The bidder is required to examine carefully the Contract Documents and the site of the work contemplated. The submission of a bid shall be considered prima facie evidence that the bidder has made such examination and has judged for and satisfied themselves as to the character, quality, and quantity of work to be performed and material required to be furnished under the Contract.

2. Vendor's Personnel Requirements

The official title of person signing the bid should be shown.

If a firm is a partnership, the full partnership name should be shown, and the bid should be signed by a partner. If a firm is a single proprietorship, the full name should be shown and the bid should be signed by the sole OWNER. If the bid of a partnership or single proprietorship is signed by a person other than the partners and OWNERS, there should be attached a written, duly acknowledged power of attorney clearly giving and showing that the signer has power sufficient to bind the partners and OWNERS of the firm to the bid.

If the firm is a corporation, and the person signing the bid is neither the president nor vice president of the corporation, there should be attached a written, duly acknowledged power of attorney or corporate resolution giving and showing that the signer has sufficient power to bind the corporation to the bid.

Sufficient evidence that the person signing the bid has the power to bind the offering company should be received by the Purchasing Division prior to the issuance of a contract.

WV DNR, Parks and Recreation is requesting bids to furnish and install Closed Circuit Television (CCTV) system, access control, and intrusion detection for the Chief Logan Recreation Center.

All work must be provided in accordance with the Specifications included herein.

Project Specifications:

Scope of work:

Vendor must furnish and install all material necessary to provide a working Closed Circuit Television (CCTV) system, access control, and intrusion detection, installed per all applicable codes and customer requirements. Vendor must integrate the CCTV digital recorder with the intrusion detection to access control software and associate the necessary alarm points with the respective cameras for "pop up" on alarm. Owner will provide 120volt circuits as needed to support new equipment.

Due to life safety and security concerns and the Chief Logan Recreation Center physical property security guidelines, these specifications herein represent the minimum acceptable system equipment characteristics. Vendors must provide "Base Bid" using this style equipment.

Project must be completed with thirty (30) days of purchase order award.

Installation Specifications

All systems must be turn-key and complete, with all pieces and parts necessary for a fully functioning system. Cable installed outside of facility must utilize EMT conduit and grounding as required by applicable code requirements. All cable must be secured above ceiling when possible using "J Hooks" or other suspension material as needed to meet applicable code requirements. Vendor must remove all unused equipment and supporting material and turn over to Owner. Vendor must install system in accordance with applicable code requirements. Vendor must furnish equipment and installation as needed to provide camera field of view as directed by the Owner for each camera, and locate monitor(s) at the location identified by the Owner. All systems including access control, intrusion, cameras, video recorders and monitors must be tested for proper functionality with documentation provided to Owner prior to project completion. Vendor must provide onsite training services to end user. All work must be completed in a neat and orderly fashion to the satisfaction of Owner.

Access Control:

SUMMARY

The access control system must integrate with existing EZFACILITY 4.0 management software, CCTV and intrusion system for video call up on alarms. Integration will include:

- Automatic database population of the access control system from EZFACILITY POS/Management software
- Camera “pop up” and play back on alarm in access control software
- Notification on forced or propped door alarm in ACS
- ID Card Printer (Provided by others)

ACS (access control system)

SYSTEM DESCRIPTION

Section includes a description of Web-hosted software services, access control devices, intrusion detection devices, security access devices, relay control, alarm monitoring controllers, credential creation and credential holder database and management.

System architecture requirements:

Software-as-a-Service Provider (SaaS Provider):

SaaS providers must offer software and system functionality on a centralized, hosted basis, rather than as an installed application that resides at a customer site. The ACS service shall be provided under this SaaS model and display all of the characteristics listed below:

- Company’s information security policies, hosting facility, applications, and staff procedures must have a current, favorable SAS-70 audit opinion.
- The SaaS Provider must host the ACS applications in a secure data facility.
- The secure data facility must have 24x7x365 staffing, including security and operational personnel.
- The Network Operations Center (NOC) must have redundant main AC power supplies, including diesel generator backup.
- The SaaS Provider must perform all system and application maintenance on behalf of the customer.
- The SaaS facility must provide secure archival data storage, including monthly offline tape backups.
- The SaaS Provider must provide automatic software upgrades. When changes are made to the central server software, those updates must be available to the customer upon the next login to the system.
- The SaaS Provider must provide on-call customer support services for the application and all associated control panels.

Web Hosted:

- The ACS application must be hosted on Web servers which are accessible via the Internet.
- The ACS application must be interoperable with common firewall and proxy server settings.

Internet Browser Accessible:

- The ACS application must be accessible via a standard Web browser over the Internet. Bioscrypt™ or equal fingerprint registration and Digital Video Recorder functionalities
- The ACS application must not follow a client/server framework, and therefore must not require any special “client” hardware or software other than a standard Web browser.
- All customer control over the application must be possible via a standard Web browser.
- The ACS application must not require the customer to install any server software whatsoever.

Encryption & Authentication:

- Sessions between the customer’s browser and the Web-based ACS application must be encrypted using 128-bit Secure Sockets Layer (SSL) encryption.
- Communications between the control panel and the ACS application servers must be encrypted using 128-bit Secure Sockets Layer (SSL) encryption.
- The SaaS Provider’s servers must validate the identity of any control panel attempting to communicate with the servers through the exchange of X509 digital certificates.
- Control panel must validate the identity of the SaaS Provider’s servers via the use of X509 digital certificates when attempting to communicate with the SaaS Provider.

Wide Area Network:

- Control panels must communicate with the central ACS application servers via either the Internet or a wide area wireless network, including wireless cellular systems.
- The wide area network (WAN) connectivity must be provided by the SaaS Provider as integral to the ACS service.
- In the case of wide area wireless connectivity, the ACS system should not require the customer to install any serial communications or network wiring to connect to the customer’s LAN/WAN infrastructure.
- In the case of Internet connectivity, the ACS system must provide an integral RJ45 connector for Category 5 Ethernet cabling to connect to the customer’s LAN/WAN infrastructure.

Central Data Storage:

- All customer and system data must be centrally stored at the SaaS Provider’s hosting facility.
- All data stored at the SaaS Provider’s facility must be backed up to a secondary (Disaster Recovery) site or to off-site storage.

Redundancy:

- All servers that are essential to providing the ACS service must be redundant.
- All communications channels between the SaaS Provider and the WAN must be redundant.
- The SaaS Provider must have a secondary set of servers located at a Disaster Recovery Facility that can provide the ACS in the event of a catastrophic disruption at the primary facility. The Disaster Recovery Facility must be at least 500 miles from the primary facility.

Web Service Application Functions:

- Data must be stored in a centrally hosted database, maintained by the SaaS Provider.
- Must provide a means for the SaaS Provider to backup and restore archival data.
- Must provide time stamps all access and system events.
- Must allow individual account administrators to set personal time zone preferences.
- Must provide customer with ability to make ACS configuration changes necessary for ensuring data integrity and facility security.
- Must provide wide range of communications protocol to control panels so that all commands and updates to the panels are verified and will be retried if communications fail.

Accounts:

Manage Company Information:

- Master administrator and all senior administrators can edit company information at any time.

Manage Passwords:

- Assignable for administrators.

Control Panels:

Create Control Panels:

- Master and all senior administrators have permission to manage control panel-related data.

Manage Control Panels:

- Assign names to panels
- Link panel to control boards and elevators

Manage control boards:

Sites:

Must enable account administrators to define and manage sites as well as all access points with the following options:

- Define and manage control panels for the account
- Define and manage control boards
- Create and manage sites
- Add doors to a site and associate them with control panels
- Enable/disable the Door Ajar feature, and control the Door Ajar Threshold
- Define and edit an Invalid PINs Threshold and define an associated Shutdown period
- Define and edit a Pass-through Period
- Manage Request-to-Exit motion sensors
- Enable and disable In/Out tracking, which logs when individual users enter and/or exit specific doors
- Enable and disable Alarm Shunts and define Alarm Shunt Delay time
- Delete doors from a site
- Add devices to a site and associate them with control panels
- Define each device as a Switch, Timer, Valid Credential, or Event Track.
- Manage a device's output behavior
- Determine if and how a device should be tracked in the Activity Report
- Delete devices from a site
- Add elevators and associate them with control panels
- Associate each elevator with one or more sites
- Associate each elevator with a card reader
- Delete elevators
- Add floors to a site
- Define and edit an Unlock Schedule for each floor
- Delete floors

Schedules and Holidays:

Must provide the ability for customer to define custom schedules for the purpose of managing facility access and operating auxiliary devices with the following options:

- Must create and edit a schedule
- Must associate a schedule with groups, floors, doors, and/or devices
- Must provide a view a list of all groups, floors, doors and devices associated with a schedule
- Must terminate a schedule's associations with one or more groups, floors, doors or devices
- Must delete a schedule
- Must create and edit a Holiday
- Must associate a holiday with one or more schedules
- Must associate a holiday with one or more doors
- Must edit a Holiday's start and end date and time
- Must delete a Holiday

Doors and Devices:

- A site must have one or more doors associated with it
- Master administrator and all senior administrators must have permission to manage doors, including permission to create the door, edit its name, and manage its security settings
- Application must provide a "View Door Relationships" page, which displays an overview of the type of access individual user groups have for a specific door
- Must be able to generate a report at any time to show all of the current relationships for a given door.

Devices:

- A device must have logical or physical inputs and outputs.
- A logical input must be a schedule input to a timer.
- A physical input must be any input point on a board.
- A site can must have one or more devices associated with it.
- Master administrator and all senior administrators must have permission to manage devices, including permission to create the device, edit its name, and manage its security settings.
- Must provide definable group permissions for Valid Credential devices.
- Must be able to generate a list of valid credential relationships.

Elevators and Floors:

- Administrator and all senior administrators must have permission to manage elevators and floors which must include creating the elevator or floor, editing its name, and managing its settings

Credentials: Credential Database, Cards, and Badges:

Credential Database:

- The Web Service application must maintain a database of all credentials associated with the account and the user to whom each is assigned.

Operations to be performed by the ACS application must include:

- Validation of card numbers that are unique, alpha-numeric, and no greater than 16 characters long
- Must allow multiple credentials per user
- Must support the creation of unique PIN credentials, four (4) to eight (8) digits long, and either randomly generated by the system or selected by the user
- Must automatically send updated credential information to the appropriate access control panels with no other user intervention
- Must provide at least fifty (50) customized fields for data storage pertaining to individual credential holders (users) registered in the system.

Cards:

- Must be assigned, revoked or deleted.
- The master administrator and all senior administrators must be able to see all cards associated with an account.
- Assistant administrators must be able to see only those cards assigned to users affiliated with groups for which they have editing permissions, and currently unassigned cards.
- Cards must be listed in numeric order on the Card Bank.
- The Web Service application must provide a page that displays the card format and the name of the user to whom the card is currently assigned if applicable.
- Must allow for deleted cards to be recreated.

Badges:

- ACS Web Service must enable administrators to create customized badges that can be used for identification as well as access control purposes.
- Master and senior administrators must be able to create, define and edit the static fields of the badges, such as company name and address.
- Master and senior administrators must be able to create and edit layouts of badges.

Administrators:

- Supports Tiered Administration, must enable an account to have one Master administrator and multiple senior and/or assistant administrators with the following options:
- Master Administrator must be able to operate on all account data, as well as view, create, edit and delete Senior and Assistant Administrators, and can control all aspects of an account.
- Multiple Senior Administrators, with permissions granted by Master Administrator. Senior Administrators must be able to operate on all account data, but cannot manage other Administrators.
- Multiple Assistant Administrators, with permissions are granted by the Master Administrator. Assistant Administrators must have access to only a subset of the account data. Depending on their permissions, they must be able to view and/or manage some site and group data, but they cannot view or manage other Administrators.

For all Administrators, the following data must be maintained:

- First Name
- Last Name
- E-mail Address
- Phone
- Time Zone
- Status
- Administrator ID
- Password
- Secret Question

Secret Answer

Must validate administrators' access to the application and track all actions, including the following aspects:

- Application must require users to supply a login ID and a password in order to gain access to an account and its associated control panels and databases.
- Must supports multiple administrators per account, each with a unique login ID and password.
- Must generate and display a non-editable, printable journal of all administrative actions performed on the account for the purpose of maintaining an unalterable audit trail.

Users and Groups:

Must manages users who have access to the sites associated with an account, and assign those users to groups that define access privileges, such as the following privileges:

- Must define a user group
- Must edit access privileges for a group of users
- Must be able to grant and revoke Keypad Unlock-Hold Privileges
- Must be able to delete a user group
- Must be able to create a new user
- Must be assign a unique four (4) to eight (8) digit PIN to a user
- Must be able to change a user's PIN
- Must be able to delete a user's PIN
- Must be able to assign a unique card number to a user
- Must be able to change user's card number
- Must be able to revoke a user's card number
- Must be able to define a user's Start Date
- Must be able to define a user's Termination Date
- Must be able to change a user's Termination Date
- Must be able to delete a user's Termination Date
- Must be able to associate and disassociate a set of fingerprints with a user's credentials using Bioscrypt™ Biometrics or equal. Software must work with the installed base.
- Must assign a user to one or more groups
- Must be able to remove a user from one or more groups
- Must be able to delete a user

Biometrics:

- Must provide an integrated, Web-based biometric support such that users can be registered to the system at the same time their biometric data is captured.
- Bioscrypt™ or equal must incorporate as an integrated solution that makes biometric security easy to implement and manage using on-line fingerprint enrollment.

Lockdown:

- Must Provide lockdown functionality that enables administrators to temporarily but instantly revoke access privileges for one or more user groups in an emergency situation.

E-Mail Notifications:

- Must dispatch e-mail notifications to select administrators when predetermined events occur, and send daily summary reports of the following events to select recipients:
 - Door Ajar/Door Ajar Cleared:
 - Door Forced Open
 - Too Many Invalid PINs
 - Unlock Schedule Restored/Door Locked by keypad
 - Unlock Schedule Overridden by Keypad/Door Unlocked by Keypad
 - Door Locked by Timer
 - Door Unlocked by Timer
 - Failed Access by Unknown Person
 - Failed Access by Known Person
 - Failed access by a user within a group
 - Successful access by a user within a group
 - Successful access by a specific user
 - Device Engaged/Disengaged
 - Control Panel/Control Board Unit Opened/Closed
 - AC Power Loss/ Restoration and Battery Status
 - Control Panel Communication Failure
- Account administrators must have the ability to manage e-mail notifications and daily summaries according to functionality listed below:
 - Create and edit notification rules specifying which administrators should receive e-mail notification of which system events
 - Associate a schedule with each notification rule
 - Specify the language to be used in notification e-mails
 - Delete notification rules
 - Create and edit a list of administrators to receive daily e-mail summaries of system events, sorted by site, user and time of occurrence

Reports:

- Must maintain an Activity Report that tracks all attempts to access the sites associated with an account, including both successful and failed attempts, with the following options:
 - Display the Activity Report unfiltered, so that all activities are listed
 - Display the Activity Report filtered by user, so that only those actions performed by a specific user are displayed
 - Display the Activity Report filtered by site, so that only those actions performed at a specific site are listed
 - Display the Activity Report filtered by door or device, so that only those actions performed on a specific door or device are listed

- Allow administrators to view the Activity Report by 20, 30 or 40 events per page
- Allow administrators to search the Activity Report for exception events, user events, control panel events and device events, searching by absolute date or relative days
- Allow administrators to search the Activity Report for events related to a specific door or device at a specific site
- Allow administrators to search the Activity Report for actions performed by a specific user on a specific door at a specific site.

Digital Video Recorders (DVRs):

- Integrates DVR, along with related Closed Circuit Television (CCTV) cameras.
- Provides the ability for an administrator to retrieve a video segment related to a
- specific event, as well as the following options:
- Add a DVR and cameras to the account at any time because no physical connection is required between the control panel and the video equipment
- Use the Activity Report as the primary point of integration between your DVR and the ACS application
- Retrieve a video segment related to a specific event
- Use the time stamp of each event to query the DVR from the Activity Report
- Stream video images directly from the browser

Controller Panels:

Power Requirements:

- The control panel must be powered from a standard 120VAC, 60Hz outlet.
- The control panel must be supplied with internal battery backup for at least four hours, and include the following functionality related to power source:
 - The control panel must indicate whether it is on main or battery backup power.
 - The control panel must send an alarm to the central ACS application when it switches between main and battery power.
 - The control panel must provide a notification to the central ACS application upon Power Up / Start-up/Reboot

Ethernet Connectivity:

- Must have one 10/100 Ethernet port for LAN connection back to SaaS Provider's NOC.
- Must have one 10/100 Ethernet Administrative Port on a physically distinct network port for privileged access to local administration functions.
- Must provide DHCP services on the Administrative Port to allow for ease of access by service personnel carrying laptops which require DHCP service to assign them and address.

Compliance:

The control panel must be listed with UL as being compliant with the UL 294 specification for access control panels.

Card Reader Technology:

- Control panels shall support multiple card reader technologies via standard Wiegand interfaces, including:
 - Wiegand effect readers
 - Proximity readers
 - Biometric readers
 - Keypads (PIN)
 - Smart Card readers supporting the following protocols: Mifare, ISOX, DESFire and iClass
 - Various biometric readers

Reader and Door Control:

Reader Communications:

- Wiegand effect readers, proximity readers, biometric readers, keypads (PINs).

Relay Outputs:

- Form C DPST Relays
- Door Lock (2)
- Alarm Shunt Relay (2)
- Auxiliary Relay (2)

Magnetic and Wiegand Formats:

Door Contact: Supervised (open/closed).

Request to Exit (REX): Monitored pushbutton or motion.

Lock Control Output:

- Output contacts rated to handle 3 amps at 24VDC

Dedicated tamper circuits.

Offline Reader Access Mode: Panel continues to function normally using existing data in the event of loss of connectivity.

Access Controlled Doors:

- Support for 30 doors per panel, no limit per system.
 - Programmable Inputs: Up to 120 per panel depending on mix of door boards and I/O boards
 - Programmable Outputs: Up to 120 per panel depending on mix of door boards and I/O boards
 - Request to Exit (REX):

Compatible with various REX devices such as push button, IR motion detector, and touch sensitive bar. ** Must be applied to meet local, state and national fire and life safety codes.

Recording:

Samsung Digital Video Recorder model 7162 or equal

Minimum Specifications:

- 3 year Warranty on parts
- 2.5TB Hard Drive

- The DVR shall be as manufactured by a reputable nationally recognized company.
- Must integrate via API to Access Control System for "Alarm call up"
- Standard MPEG-4 compression
- Network – 1 LAN port 10/100/1000 Base T
- Rec. Real-time on 16 cameras:480ips (NTSC)
- Built in Internal DVD R/W
- Simultaneous recording & transmission : dual codec function
- Net-i connected
- Support POS(I/F VSI - pro)(option)
- Web based monitoring & search
- Simultaneous BNC output & VGA / BNC output & HDMI
- Stable system operation : remote diagnosis function

DVR UPS and Surge protection:

Minimum Specifications:

Cyberpower – model OL1000RMXL2U - or equal.

- True online double conversion.
- 2U rack or vertical orientation.
- 8 x NEMA 5-15R receptacles
- EMI, RFI, surge and lightning protection.
- 3 (three) 12V/7Ah batteries (36V),
- Pure Sinewave power
- Communication including RS232, USB, or SNMP/AS400 card

Cameras:

Minimum Requirements

- All outdoor cameras must include lighting suppressors
- 3 year warranty on parts
- Indoor camera cable must be plenum; conduit as needed to protect against vandalism.

Indoor Cameras

Samsung model 5368 or equal

- 1/3" 410K/470K Pixels Super-HAD IT CCD
- High Resolution : 600 TV Lines
- Min. illumination 0.00023Lux (F1.2, 15 IRE, Sens-Up 512x)
- SCC-B5366: f=2.5~6mm, Auto Iris Lens; SCC-B5368 f=2.8~11mm,
- Auto Iris Lens
- Internal/Linelock (Phase Control) Function
- Electronic Day/Night Function, Sens-Up Function (512x)
- Motion Adaptive Digital Noise Reduction (3D+2D)
- Back Light Compensation (Area Setting)
- Extended Dynamic Range (XDR)

- Privacy Mask Function (Polygonal Mosaic)
- DIS (Digital Image Stabilization)
- CCVC (Camera Control Via Coaxial cable, Controller: SCX-RD100)
- Multi-Language OSD support
- Horizontal & Vertical Image Mirroring
- Positive / Negative Imaging
- DC12V & AC24V 60Hz(50Hz)

Pool Area Camera's

Samsung model SCC-B5399H or equal

- 1/3" 410K/470K Pixels Super-HAD PS CCD
- High Resolution : 600 TV Lines
- Min. Illumination: 0.0002Lux (F1.2, 15 IRE, Sens-Up 512x, Color), 0.00002Lux (F1.2, 15 IRE, Sens-Up 512x, B/W)
- SCC-B5399H: f=2.8~11 mm, Auto Iris Lens
- Wide Dynamic Range (WDR)
- Virtual Progressive Scan (VPS)
- Internal/Linelock (Phase Control) Function
- True Day/Night Function (ICR), Sens-Up Function (512x)
- Motion Adaptive Digital Noise Reduction (3D+2D)
- Back Light Compensation (Area Setting)
- Extended Dynamic Range (XDR)
- Privacy Mask Function (Polygonal Mosaic)
- DIS (Digital Image Stabilization)
- CCVC (Camera Control Via Coaxial cable, Controller : SCX-RD100)
- Multi-Language OSD support
- Horizontal & Vertical Image Mirroring
- Positive / Negative Imaging
- Extreme Weather Resistant, Anti Vandal type, IP-66, Surface type
- DC12V & AC24V 60Hz(50Hz)

For Parking Lot Area Brick Cameras

(Camera must be in weather proof housing, IP66 Rates, with Heater/Blower)

- 1/3" 410K/470K Pixels Super-HAD PS CCD
- High Resolution : 600 TV Lines
- Min. illumination 0.0002Lux (F1.2, 15 IRE, Sens-Up 512x), 0.00002Lux (F1.2, 15IRE Sens-Up 512x, B/W)
- Internal/Linelock (Phase Control) Function
- ALC (Video/DC) / ELC
- Wide Dynamic Range (WDR)
- Virtual Progressive Scan (VPS)
- Day/Night (ICR), Sens-Up Function (512x)
- Motion Adaptive Digital Noise Reduction (3D+2D)
- Back Light Compensation (Area Setting)

- Extended Dynamic Range (XDR)
- Privacy Mask Function (Polygonal Mosaic)
- High Shutter Speed Control by External Trigger
- DIS (Digital Image Stabilization)
- CCVC (Camera Control Via Coaxial cable, Controller: SCX-RD100)
- RS-485 (Half) Control (Multi-Protocol Support)
- Multi-Language OSD support
- Intelligent Video (Moved / Fixed / Fence [Area and Line Mode] / Area / Tracking)
- Horizontal & Vertical Image Mirroring
- Positive / Negative Imaging
- C/CS Lens Mount Compatible
- DC12V & AC24V 60Hz(50Hz)

Display:

Samsung model SMT-4222 or equal

Club Manager's office - 40 inch display located in will sequence all cameras from PC driven software. Owner will provide PC with 256meg AGP video card to support display requirements and power at mounting locations.

Samsung model SMT-3222 or equal

Front desk - Dual 32 inch monitors will display all cameras on a full time basis. Owner will provide power at mounting locations.

Minimum Specifications:

- 3 year Warranty on parts
- Anti Image Burn/Pixel Cleansing
- Extended Video Wall Format
- Picture in Picture(PIP) and Picture by Picture(PBP)
- 178 degree horizontal and vertical viewing angle
- 8ms Response Time
- 24/7 Operation with Built in Power Supply
- Video, BNC, HDMI
- Anti-image retention
- Matrix Video Wall (2x2, 3x3, 4x4,1x5, 5x1, 5x5)
- Analog RGB, DVI-D, Composite S-Video, Component Video
- Contrast 4000:1
- Resolution 1366x768, 500 lines

Intrusion Alarm System:

GE Security model Networx NX-8 or equal

Product Specifications:

Basic Control Hardware

- Meets UL standards (UL609, UL 985, UL 1023, UL1610, UL 1637)

- Meets FCC standards (Part 68 and Part 15)
- Complies with EN directives (EN50081-1, EN50130-4, EN55022, EN60950, EN61000-3-2, EN61000-3-3 and EN60950 1999-4 3rd addition)
- Vertical side-in form factor PCB.
- 16.5 VAC 50/60 Hz input (25, 40, or 50 VA).
- Mains failure detection.
- Auxiliary power output (12 VDC @ 500mA with 25VA transformer or 12VDC @ 1Amp with 40VA, 50 VA).
- Built-in battery charging circuit.
- Dynamic battery test.
- Low battery detection.
- Integrated static and surge suppression on external circuits.
- Fuseless design.
- 8 on-board zones.
- 3.3K end of line zone resistor support.
- Maximum of 8 keypads per partition.
- Maximum of 24 devices per system.
- 4 on-board outputs.
- 2-wire or 4-wire smoke detector compatible.
- Separate current limited smoke detector power output.
- Built-in siren driver/voltage out. (supervised)
- Integrated POTS interface. (w/ full seizure)
- DTMF and pulse dialing.
- Voltage and current telephone line monitor.
- Box tamper input.
- Audio tap to allow low-cost listen-in and 2-way voice support.
- Maximum keypad or module distance is 2,500 feet from the panel.

Basic Control Software Features:

- Expandable to 48 zones.
- 8 customizable partitions.
- 99 users.
- 4 or 6 digit user codes.
- Optional programmable zone double feature for 16 on-board zones.
- All zones programmable as fire or burglary.
- 20 customizable pre-configured zone types.
- Up/downloadable with competitor lockout.
- Force arming by zone type.
- Automatic arming with auto retry. (In the exit mode ONLY)
- 185 event history log. (w/ date, time, event, partition number and user/zone number)
- 3 central station telephone numbers. (w/ selectable formats) (20 digits)
- 15 reporting formats. (10pps, 20pps, 40pps, (3/1, 4/1, 4/2) SIA, Contact ID, pager and custom)

- 16 reporting group selections per CS number.

Partitioning:

- Up to eight (8) true partitions.
- Unlimited number of common areas
- Assign zones to one or multiple partitions for common areas.
- Separate account code for each partition.
- User code assignment to multiple partitions:
- Separate feature selections for each partition.
- Independent entry/exit delays for each partition.

SIA False Alarm Prevention Features:

- Audible/visual exit delay countdown warning.
 - Keypad beeps slowly until the last 10 seconds of the exit delay.
 - During the last 10 seconds the keypad beeps quickly, and the exit light flashes.
- Exit error reporting.
 - A special report to the central station that indicates the exit door had not closed at the time the exit delay expired.
 - Indicates to the central station that the alarm was caused by user error.
- Recent closing reports.
 - Advises the central station that a zone alarm occurred within 5 minutes of a closing.
- Programmable abort delay.
 - Alarm can be programmed to delay reporting to central station.
 - Siren or bell will sound.
 - User can enter code and "Cancel" button to prevent signal being sent to central station
 - Visible confirmation of cancellation.
 - Can be programmed to abort with only the user code.
- Cross zoning.
 - Requires 2 trips from separate zones to cause alarm.
 - Set two or more zones as cross zones, and then set cross zone time.
 - Setting a single zone as a cross zone will cause a double trip zone, "double knock".
- Swinger shutdown by zone type.
 - Control panel will only report a fault on the zone a programmable number of times before bypassing that zone.
 - Used to limit problems caused by a single detector.
 - Programmable by zone.
 - Only affects a single arming cycle.
- Fire alarm verification.
 - Requires 2 trips of a smoke detector.
 - First trip causes panel to reset smoke power.
 - Second trip within a programmable period of time causes alarm.

- Reduces system caused false alarms.

Programmable Options:

- CS and Download phone numbers.
 - Up to 3 20-digit separate CS numbers can be programmed.
 - 1 20-digit download number for site initiated sessions.
 - DTMF or pulse dialing options.
 - Programmable end of number and 4 second delay.
- CS account codes. (by telephone number or partition)
 - Supports 3-6 digit account numbers. (w/ Hex characters)
- Selectable number of dial attempts and backup configuration.
 - 1-15 dial attempts per number.
 - Supports split, dual and backup reporting.
- Download access configuration.
 - Dial in support.
 - Two (2) forms of answering machine defeat. (Two (2) ring or tone sniff)
 - Selectable site and/or remote initiated.
 - 8 digit access code.
- Keypad duress code.
 - Separate 4 or 6 digit PIN.
- Keypad multiple key press tamper.
 - Can be enabled to detect 25-30 non-valid key presses.
 - Will lock-out further key presses for pre-determined amount if time.
- Quick arm and re-exit.
 - Single button arming with Stay and/or Exit keys.
- Emergency keys.
 - Optional keypad panic (audible)
 - Optional keypad holdup (silent)
 - Optional keypad Fire
 - Optional Keypad Medical
- Keypad LED extinguish option.
 - Turns off keypad LEDs and backlights when there is no alarm or user activity.
- Automatic Stay/Away option.
 - Option to bypass interiors if no exit is detected.
 - Option to have all exterior zones instant or delay.
- Selectable partition reports.
 - Open and close reports.
 - Bypass reports.
 - Restore reports.
 - Trouble reports.
 - Cancel reports.
 - Recent closing report.
 - Exit error report.
 - Late to open/early to close.

- Programmable entry and exit delays.
 - 2 entry delays, global or per partition. (30-255 seconds)
 - 2 exit delays, global or per partition. (45-255 seconds)
 - Additional partition feature selections.
 - Code required for zone bypass.
 - Interior bypass toggle. (while armed)
 - Sound keypad at arming when zone bypassed or AC/ battery trouble.
 - Silent arm in Stay mode.
 - Flexible zone selection.
 - Can select 1 of 20 preconfigured zone types for each zone.
 - Each zone can be disabled by removing from all partitions.
 - Each zone can be active in any valid partition.
 - Flexible zone configuration.
 - Pre configured zone configurations can be easily customized for special use.
 - Chime
 - 24 hour
 - Delay 1 or 2
 - Local (non-reporting)
 - Bypassable
 - Group shunt
 - 50 or 500ms response
 - 20 event types (see Appendix 2)
 - Follower (will be instant when not in an entry delay)
 - Sound keypad and/or siren (yelping or temporal)
 - Fully programmable pulse format codes for special events.
 - Events are pre-coded for SIA and Contact ID. (see Appendix 1)
 - Can select any 2-digit combination. (separate restore code if applicable)
 - Siren / bell triggers and options.
 - Telephone line cut. (while armed)
 - Telephone line cut. (while disarmed)
 - Short blast when armed.
 - Short blast at exit expiration.
 - Short blast at CS kiss-off.
 - Timing cross-zone.
 - Zone or box tamper.
 - Blast once for arm, twice for disarm when from wireless or key-switch zone.
 - Expander trouble (missing).
 - During manual test (*44).
 - Disable temporal for fire.
 - Voltage output (used with bell or external siren driver).
 - Keypad sounder triggers.
 - Telephone line cut. (while armed)
 - Telephone line cut. (while disarmed)
 - AC power failure.
- | | |
|-----------------|------------------------------|
| ○ Fire | ○ Cross-zone |
| ○ Keyswitch | ○ Dialer delay |
| ○ Interior | ○ Swinger shutdown |
| ○ Force armable | ○ Allow restore report |
| ○ EOL defeat | |
| ○ Entry guard | ○ Listen-in |
| ○ Double EOL | ○ Trouble (day or fire zone) |

- Low system battery.
- Timing cross-zone.
- Zone or box tamper.
- Expander trouble (missing).
- System feature selections.
- Instant zone restore.
- Enable 12-second battery missing test.
- Enable battery test at arm time (instead of disarm).
- Send manual test message to CS during *44 test.
- Enable on-board box tamper.
- Show service for lost time.
- Enable zone doubling.
- Disable on-board zones.
- 2 trips okay for cross-zone alarm.
- No bypass report for force armed zones.
- Use crystal as time base in place of 50/60 Hz.
- Enable walk-test start and end reports
- Auto LED extinguish.
- 4 or 6 digit user codes.
- Require code for site-initiated download.
- Enable auto-cancel / abort.
- Enable walk-test mode.
- System report enables.
- Box tamper AC fail Low battery
- Aux. power over current Siren supervision Telephone line
cut
- Ground fault Expander trouble Fail to
communicate
- Log full Auto-test Start/end
Programming
- End of download Sensor low battery Sensor
missing
- Swinger shutdown.
- Pertains only to zones whose configuration allows for swinger shutdown.
- Number of trips allowed for each armed cycle before zone is bypassed.
- System Timers.
- Dynamic battery test duration (0-255 minutes).
- AC failure report delay (0-255 minutes).
- Power-up delay on zones (0-60 seconds).
- Siren time (1-254 minutes).
- Telephone line cut delay (0-255, 0 disables feature).
- Cross-zone time (0-255, 0 disables feature).
- Chime time (50ms per count) (0-255, 0 follows zone, 255 latches).
- Dial delay (15-255 seconds).
- Fire alarm verification period (120-255 seconds, 0= no verification).
- Listen-in time (0-255, 0 disables feature).
- Installer code.

- Special four (4) or six (6) digit PIN for access to installer features.
- Enables for user functions.
- Enables for user partition access.
- Programmable output configuration.
- Auto-test.
 - Selectable interval (days or hours)
 - Must be able to be suppressed of other signals occurred during interval.
 - Must be able to set to send at selected time.
- Open and close windows.
 - Must be able to set the time of day and days of week for normal hours.
 - Must be able to be assigned to any/all partitions.
- Auto-arm.
 - Must be able to set to the hours and minutes for normal arming.
 - Must be able to select which partitions follow schedule on which days.

Service:

Vendor must provide 24x7x365 on call service and support. Vendor must provide on-site service to the Chief Logan Recreation Center within two (2) hours of request.

License:

Vendor must provide a copy of their West Virginia State contractor's license with the bid.

Safety:

Vendor must provide a copy of their standard safety policy manual.

DNR210080 - Chief Logan Recreation Center
 CCTV Project at Chief Logan Recreation Center, Logan, WV
 EQUIPMENT LIST

Please complete the below information concerning the brand(s) of equipment being bid in relation to this project. If bidding "equal" products, please attach manufacturer's literature (in the form of technical specification cut sheets) documenting the adherence to the mandatory requirements stated in the specifications.

Item Description	Manufacturer	Model	Literature Attached
DVR	AS SPEC'D		
Cameras for Harsh Environment (pool)	AS SPEC'D		
Bricks for the Parking Lot (outside)	AS SPEC'D		
Lenze for Brick Camera	AS SPEC'D		
Interior Dome camera	AS SPEC'D		
Brick Enclosures for Outside	AS SPEC'D		
Bracket for Domes	AS SPEC'D		
Ditek Outdoor Lightening Protection	AS SPEC'D		
Camera Power Supply	PELCO	MCS Series	YES
Cyberpower Battery Back UP	AS SPEC'D		
32" Wall Mount	AS SPEC'D		
40" Wall Mount	AS SPEC'D		
32" LCD in Offices	AS SPEC'D		
40" LDC in Manger Office	AS SPEC'D		
Vicon Ground Loop Transformer	AS SPEC'D		
Brivo Hardware for Access Control	AS SPEC'D		
Mag Lock	SECURITRON	M6Z	YES
Bracket for mag lock	SECURITRON	ZA32CL	YES
Card Reader w/J Box Grey (940)			
Pushbutton with timer	SECURITRON	EEB2	YES
Request to Exit PIR	SECURITRON	XMS	YES
HID Reader	ASUSPEC'D		
Burg Panel	AS SPEC'D		
12 7ah battery	AS SPEC'D		
16 Zone Expander Module	AS SPEC'D		
Digital Voice Dialer	USP	AD2000	YES

DNK210080 - Chief Logan Recreation Center
 CCTV Project at Chief Logan Recreation Center, Logan, WV
 EQUIPMENT LIST

Ceiling Mount PIR	AS SPEC'D	
Ceiling Plate	AS SPEC'D	
Wall Mount PIR	AS SPEC'D	
Wall Plate	AS SPEC'D	
Remote Power Supply	AS SPEC'D	

PRODUCT SPECIFICATION

MCS Series Power Supply

MULTIPLE 24 VAC POWER SUPPLY, INDOOR

Product Features

- 2, 5, 10, or 20 A Capacities
- 4, 8, or 16 Outputs
- Fuse or Circuit Breaker Protection;
Spare Fuses Included with Fused Models Only
- 120 VAC or 240 VAC Selectable Input
- 24 VAC Output or 28 VAC Output for Longer Wire Runs
- AC Power Indicator with Power On/Off Switch
- Compatible with Cameras, Domes, and Pan/Tilts
- Models with Circuit Breakers Have Class 2 Rated Outputs

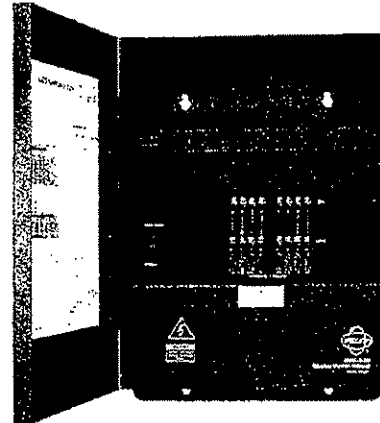

MCS16-10

Power supplies in the **MCS Series** offer a variety of configurations for powering up to 16 units from a single power source.

The power supplies provide 24 VAC output for 4, 8, or 16 units. To compensate for voltage losses over long wire runs, 28 VAC outputs also are available on most models. The power supplies have a selectable input of 120 or 240 VAC and are packaged in an easy-to-install metal enclosure that has ample room for wiring connections and conduit entries.

For integrated systems such as Spectra® and Esprit®, the higher capacity models are capable of handling pan/tilt and receiver operation in addition to camera functions. (See product capacity chart.)

Models are available with either fuses or self-resetting circuit breakers on each output. Fused models provide a greater degree of protection for the camera because they are faster acting and more precise. Circuit breakers will self-reset when the fault is corrected, eliminating the need for replacing fuses. However, the amount of current required to trip a circuit breaker can vary as much as 100 percent depending on temperature. In the fused models, the values of fuses can be changed depending upon the specific current requirements of the equipment connected.

The **MCS16-10S**, **MCS16-10SB**, **MCS16-20S**, and **MCS16-20SB** are 16-output supplies that have individual power switches and LEDs on each output. This is a popular feature in larger systems where it is frequently necessary to power down individual units.

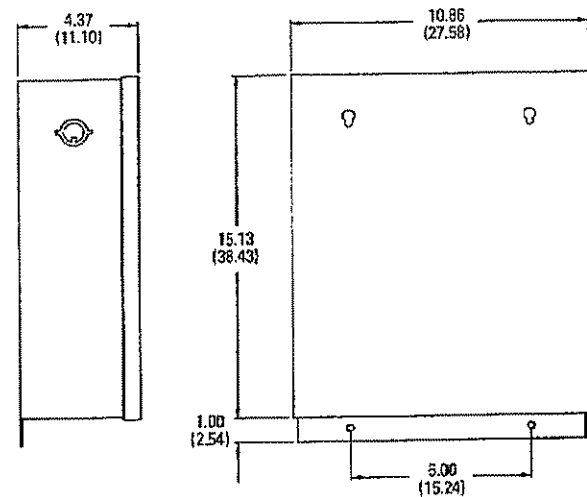

NOTE: VALUES IN PARENTHESES ARE CENTIMETERS;
ALL OTHERS ARE INCHES.



CAES / REVISED 3-07

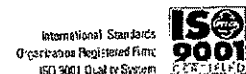

MODELS

MCS4-2	Indoor multiple power supply, 120/240 VAC input, 4 fused 24 VAC outputs, total current capacity of 2 A (48 VA).
MCS4-2B	Same as MCS4-2 except has circuit breakers.
MCSB-5	Indoor multiple power supply, 120/240 VAC input, 8 fused 24/28 VAC outputs, total current capacity of 5 A (120 VA).
MCSB-5B	Same as MCSB-5B except has circuit breakers.
MCS16-10	Indoor multiple power supply, 120/240 VAC input, 16 fused 24/28 VAC outputs, total current capacity of 10 A (240 VA).
MCS16-10B	Same as MCS16-10 except has circuit breakers.
MCS16-10S	Same as MCS16-10 except each output has a power switch and power indication LED.
MCS16-10SB	Same as MCS16-10S except has circuit breakers.
MCS16-20	Indoor multiple camera power supply, 120/240 VAC input, 16 fused 24/28 VAC outputs, total current capacity of 20A (480 VA).
MCS16-20B	Same as MCS16-20 except has circuit breakers.
MCS16-20S	Same as MCS16-20 except each output has a power switch and power indication LED.
MCS16-20SB	Same as MCS16-20S except has circuit breakers.

Output Fuse/ Circuit Breaker Ratings	
MCS4-2, MCS4-2B	1.5 A*
All other models	3 A*

Input Connectors	Wire nut
Output Connectors	Screw-type barrier strips; models with circuit breakers are suitable for Class 2 wiring
Input Wire Size	12-16 gauge solid wire
Output Wire Size	12-22 gauge solid or stranded wire
Recommended Wiring Distances	See chart below

The following are the recommended maximum distances (transformer to load) and are calculated with a 10% voltage drop. (10% is generally the maximum allowable voltage drop for AC-powered devices.) Distances are calculated in feet; values in parentheses are meters.

Recommended Wiring Distance Chart

Input Voltage	Total VA Consumed	Wire Gauge		
		20 AWG (0.5 mm ²)	18 AWG (1.0 mm ²)	16 AWG (1.5 mm ²)
24 VAC	10	283 (86)	451 (137)	716 (218)
	20	141 (42)	225 (68)	358 (109)
	30	94 (28)	150 (45)	238 (72)
	50	56 (17)	90 (27)	143 (43)
28 VAC	10	386 (117)	614 (187)	975 (297)
	20	193 (58)	307 (93)	487 (148)
	30	128 (39)	204 (62)	325 (99)
	50	77 (23)	122 (37)	195 (59)

Product Capacity Chart

A partial list of compatible products and the number of units that may be powered by each power supply are listed below. Capacity is based on the VA rating of each product to be used with the power supply.

Product	Power Supply Model			
	MCS4-2/ 4-2B (48 VA)	MCSB-5/ 8-5B (120 VA)	MCS16-10/ 16-10B (240 VA)	MCS16-20/ 16-20B (480 VA)
CCD Camera (1.2 VA)	4	8	16	16
Indoor CF5 with camera (3 VA)	4	8	16	16
Indoor DF8 with camera (12 VA)	4	8	16	16
Indoor Spectra (25 VA)	1	4	8	16
Esprit (70 VA)	—	1	3	6

MECHANICAL

Cable Entry 4 knockouts for either 1/2-inch (1.27 cm) or 3/4-inch (1.91 cm) conduit

ELECTRICAL

Input Voltage 120 or 240 VAC, 50/60 Hz
 Output Voltage
 MCS4-2 24 VAC
 All Other Models 24/28 VAC

GENERAL

Construction	Steel
Finish	Charcoal black polyester powder coat
Environment	Indoor
Operating Temperature	32° to 120°F (0° to 49°C)
Weights	Unit Shipping
MCS4-2	14.10 lb (6.40 kg) 17 lb (7.71 kg)
MCS4-2B	13.89 lb (6.30 kg) 17 lb (7.71 kg)
MCSB-5	17.05 lb (7.73 kg) 20 lb (9.07 kg)
MCSB-5B	16.85 lb (7.64 kg) 20 lb (9.07 kg)
MCS16-10	20.72 lb (9.40 kg) 24 lb (10.89 kg)
MCS16-10B	20.72 lb (9.40 kg) 24 lb (10.89 kg)
MCS16-10S	20.35 lb (9.23 kg) 23 lb (10.43 kg)
MCS16-10SB	20.48 lb (9.29 kg) 23 lb (10.43 kg)
MCS16-20	22.50 lb (10.21 kg) 26 lb (11.79 kg)
MCS16-20B	22.47 lb (10.19 kg) 26 lb (11.79 kg)
MCS16-20S	22.27 lb (10.10 kg) 25 lb (11.33 kg)
MCS16-20SB	22.28 lb (10.11 kg) 25 lb (11.33 kg)

CERTIFICATIONS/RATINGS

- CE
- UL Listed
- UL Listed to Canadian safety standards
- China Compulsory Certification
- Meets NEMA Type 1 standards

*Individual output cannot exceed this rating, and the total of all outputs cannot exceed the overall rating of the power supply (see the Models section).



Pelco, Inc. Worldwide Headquarters:
 3500 Pelco Way, Clovis, California 93312-5899 USA
 USA & Canada Tel: (800) 289-9100 • FAX: (800) 289-9150
 International Tel: +1 (559) 292-1991 • FAX: +1 (559) 348-1120
 www.pelco.com

Pelco, the Pelco logo, Spectra, and Esprit are registered trademarks of Pelco, Inc. Product specifications and availability subject to change without notice. ©Copyright 2007, Pelco, Inc. All rights reserved.

SECURITRON
ASSA ABLOY

ASSA ABLOY, the global leader
 in door opening solutions

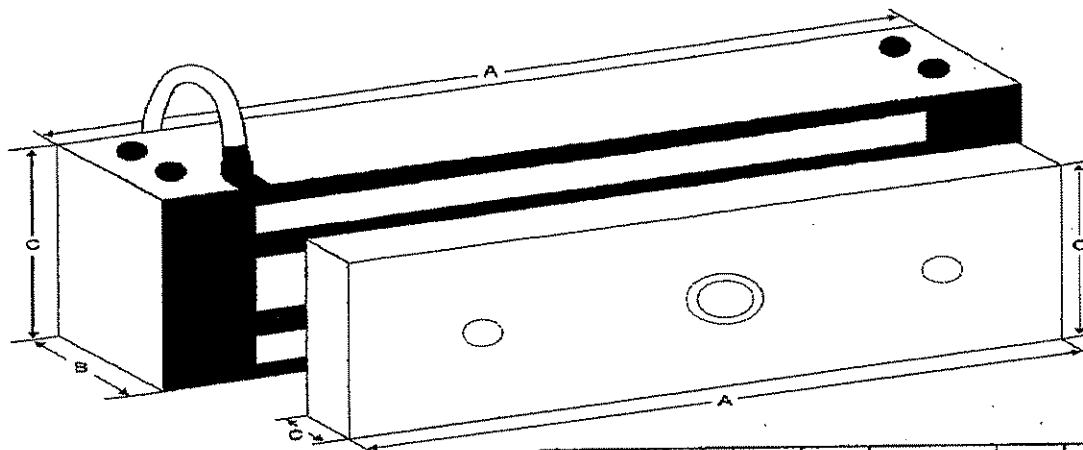

MODEL 62 MAGNET	A	B	C	MODEL 62 STRIKE	A	B	C
	8	1.75	2.9		6	2.75	.5

ELECTROMAGNETIC LOCK – Model 62

Features

- 1,200 pounds of pull-apart holding force
- Lifetime replacement warranty
- Power consumption of 250mA @ 12VDC & 150 mA @ 24VDC – 3 Watts
- Automatic dual voltage, 12 VDC or 24 VDC, no field adjustment required
- Instant release circuit, no residual magnetism
- Surface mounts using only a drill and allen wrench
- Fully sealed electronics, tamper proof & weather proof
- Mounted using steel machine screws into blind finishing nuts
- Architectural brushed stainless steel finish
- Polished brass, clear anodized, & polished stainless finish dress covers available
- Hardware accessories include brackets, housings, and dress covers as needed for every opening type
- Ten feet of jacketed stranded conductor
- Lock and strikes plated to provide corrosion resistance
- Fail Safe
- UL listed

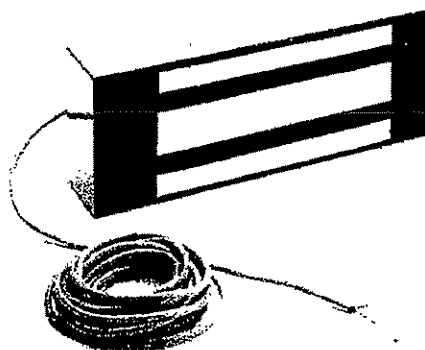

Securitron Magnalock Corporation
 550 Vista Boulevard
 Sparks, NV 89434

Tel 775.355.5625
 Fax 775.355.5636
 info@securitron.com
 www.securitron.com



Electromagnetic Lock Accessories



(ZA) Z Bracket Kits - Adjustable

- Used on inswing doors with the "F" type Magnalock 8.5" overall length
- Provides 1.25" of lateral movement to accommodate most openings and allows for precision adjustments (2-1/4" to 3-1/2" from door/header)
- Includes an oversized dress cover

- ZA-32/62CL Adjustable Z Bracket M32/M62 Clear
- ZA-32/62BK Adjustable Z Bracket M32/M62 Black
- ZA-32/62SS Adjustable Z Bracket M32/M62 Stainless Steel
- ZA-82CL Adjustable Z Bracket M82 Clear
- ZA-82BK Adjustable Z Bracket M82 Black
- ZA-82SS Adjustable Z Bracket M82 Stainless Steel

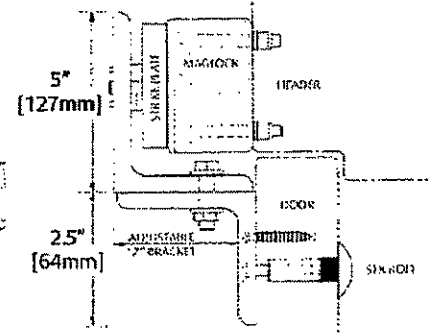

(TJ) M38/M68 Inswing Door Kit - Top Jamb

- Used to mount the M38 or M68 lock on the secure side of a door that swings into a secured area
- Includes a Z Bracket and an oversized Dress Cover

- TJ-38CL Inswing Door Kit M38 Clear
- TJ-38BK Inswing Door Kit M38 Black
- TJ-68CL Inswing Door Kit M68 Clear
- TJ-68BK Inswing Door Kit M68 Black

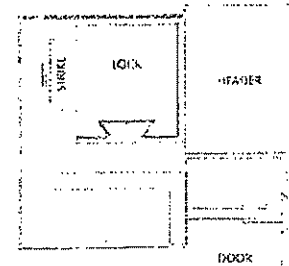
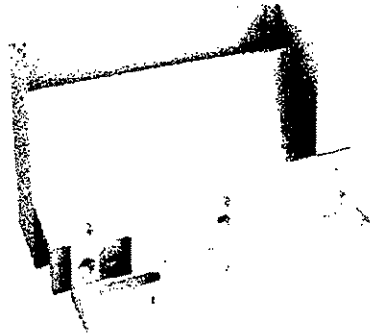

(ASB) Aluminum Spacer Bracket

- Used when a blade stop requires the Magnalock to be lowered
- Comes pre-drilled (lock specific) for the mounting bolts and wire
- Provides a blind nut for surface installation of strike

- ASB-32CL Alum Spacer Bracket M32 Clear - 8"
- ASB-32BK Alum Spacer Bracket M32 Black - 8"
- ASB-62CL Alum Spacer Bracket M62 Clear - 8"
- ASB-62BK Alum Spacer Bracket M62 Black - 8"
- ASB-82CL Alum Spacer Bracket M82 Clear - 12"
- ASB-82BK Alum Spacer Bracket M82 Black - 12"

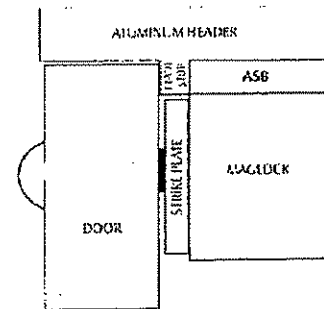

(UHB) Universal Header Bracket

- Use to extend the header from 1 to 1-1/2" inches
- Provides a concealed wiring chamber

- UHB-CL-8 Universal Header Bracket Clear - 9-1/2"
- UHB-BK-8 Universal Header Bracket Black - 9-1/2"
- UHB-CL-12 Universal Header Bracket Clear - 13-1/2"
- UHB-BK-12 Universal Header Bracket Black - 13-1/2"

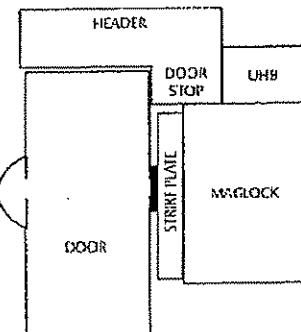
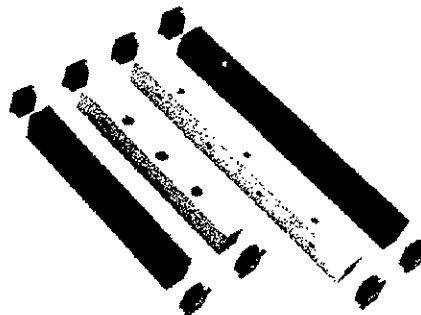



ASSA ABLOY, the global leader in door opening solutions

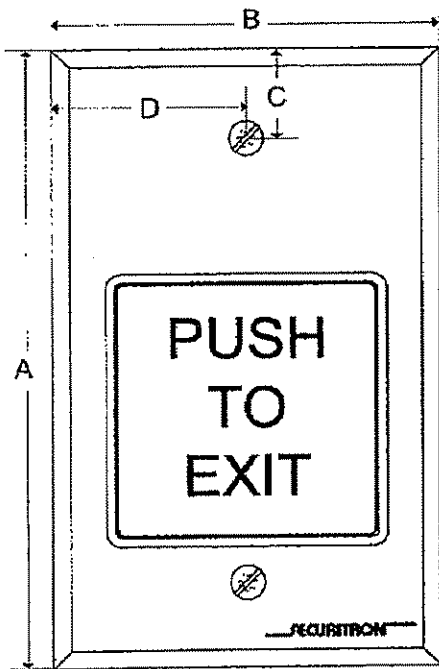

MODEL	A	B	C	D	DEPTH
EEB2	4.5	2.75	.625	1.375	3

NOTE: FASTENERS NOT SHOWN ALL DIMENSIONS IN INCHES.

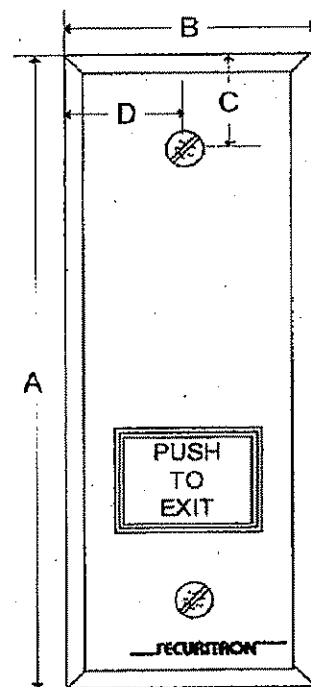

MODEL	A	B	C	D	DEPTH
EEB3N	4.5	1.75	.625	.875	3

NOTE: FASTENERS NOT SHOWN ALL DIMENSIONS IN INCHES.

PUSH BUTTON W/ INTEGRATED TIMER—EEB2 & EEB3N

Features

- Integrated retriggerable 30 second timer
- Field selectable 12 VDC or 24 VDC
- Mounted on a stainless steel single gang faceplate (narrow stile available on EEB3N)
- Internal double break wiring
- 3 amp contacts
- Meets Life Safety Code when used in conjunction with a motion sensor

Operating Temperature
0 to 43C [32 to 110F]

How to Order

Part #	Description
EEB2	Emergency Exit Button w/ timer single gang
EEB3N	Emergency Exit Button w/ timer narrow stile

Securitron Magnalock Corporation
 550 Vista Boulevard
 Sparks, NV 89434

Tel 775.355.5625
 Fax 775.355.5636
 info@securitron.com
 www.securitron.com



ASSA ABLOY, the global leader
in door opening solutions

PUSH BUTTON W/ INTEGRATED TIMER—EEB2 & EEB3N (cont'd)

Architectural Specification—Push Button w/ Integrated timer (EEB2, EEB3N)

- A. The EEB2 Push Button with Integrated Timer shall be produced by an ISO 9001 certified manufacturer
- B. The Push Button shall have a limited lifetime warranty covering malfunction and abuse.
- C. The Push Button shall be a 2" by 2" (1 x ¾ for EEB3N) industrial grade button with protective cowling.
- D. The Button shall be labeled "PUSH TO EXIT" and shall be non-illuminated.
- E. The unit shall operate on 12 or 24 VDC (field selectable).
- F. The retriggerable, 30 second code mandated timing function shall be automatically activated as shall the double break control of the magnetic lock, for additional safety. The timer shall be non-adjustable.
- G. The push button shall be mounted on a stainless steel single gang (Narrow stile for EEB3N) faceplate.

Rev 11-15-01



ASSA ABLOY, the global leader
in door opening solutions

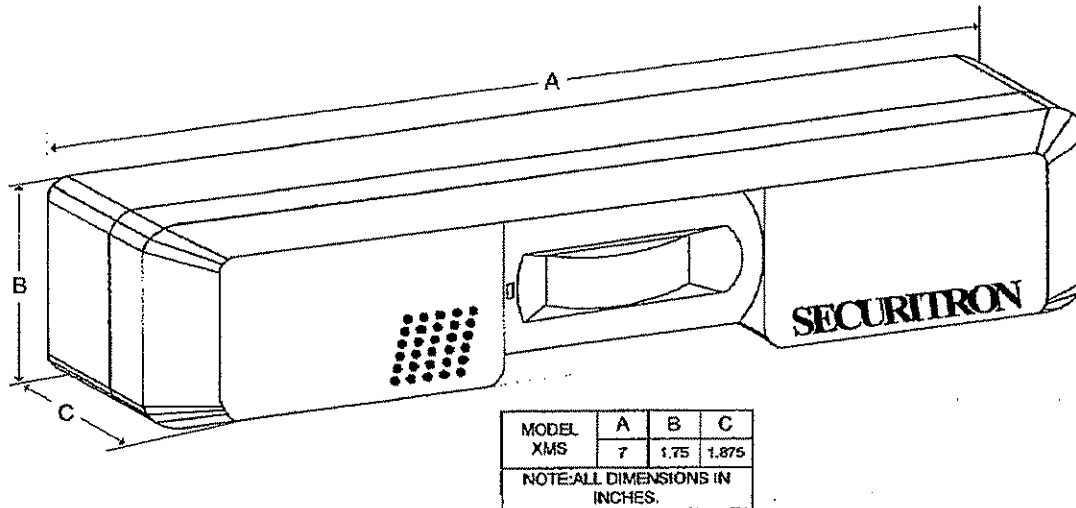

EXIT DEVICE – XMS

Features

- Passive Infrared
- 12 OR 24 VDC
- Indoor use only
- Low current draw 20-50 mA depending on switching status
- Specifically designed to reliably release magnetic locks

Operating Temperature
0 to 43C [32 to 110F]

How to Order

<u>Part #</u>	<u>Description</u>
XMS	Exit Motion Sensor

Architectural Specifications

- The Exit Motion Sensor shall be produced by an ISO 9001 certified manufacturer.
- The exit device shall employ passive infrared detection to initiate door release and shall operate on 12 or 24 volt DC.
- The device shall have an adjustable detector face to allow for precise pattern configurations, and easy pattern adjustment.
- The exit device shall have a SP/DT relay output for shunting the alarm or access control system and field effect transistor for direct control of an electromagnetic lock.
- The relay shall operate 50 milliseconds before the transistor to suppress false alarms.
- Wiring is via labeled screw terminals.

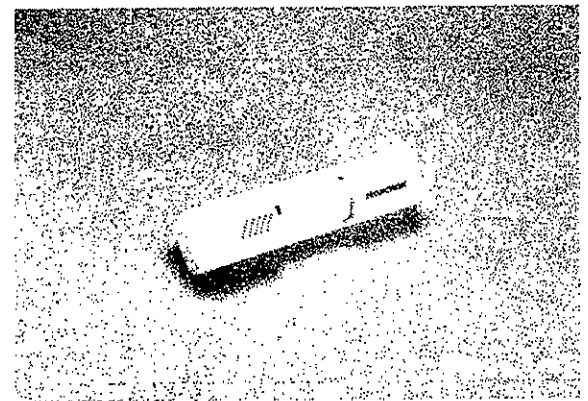

MODEL AD-2000

Automatic Voice/Pager Dialer System with Verification

Not just the next generation...it's the next millennium!

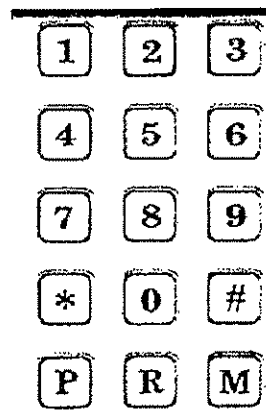
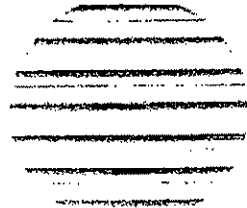

AD-2000

Automatic Voice/Pager Dialer

Versatile * Full-featured * Easy to Program

2-way Listen in Verification
Operates with all alarm systems
Ideal stand-alone dialer

Provides reliable emergency notification 24 hours a day



United Security Products, Inc.

**PLEASE READ THIS MANUAL BEFORE PROGRAMMING AND USING THE UNIT.
IMPORTANT: SAVE THESE INSTRUCTIONS**

MODEL AD-2000

Owner's Manual and Operating Instructions The Automatic Voice/Pager Dialer System *For The Next Millennium*

Congratulations!

Thank you for purchasing United Security Products, Inc.'s Model AD-2000 - the "smartest", most comprehensive automatic voice/pager security dialer available. Representing an exciting new level of achievement, the AD-2000 combines technologically advanced features, ease of programming and reliable operation in a compact, unobtrusive dialer completely compatible with any security alarm system. Installation and hookup are quick and easy, whether installed in conjunction with normally open, normally closed dry contact or voltage activation sensors. The unit can also function as a stand-alone device, by simple connection to an ordinary telephone jack. The keypad cover glides on and off for added attractiveness and security.

How It Works

The AD2000 dialer features busy-line and no-answer detection to ensure prompt transmission of up to 4 prerecorded messages delivered sequentially to as many as 8 standard telephones, cellular phones, voice and/or numeric pagers. Messages to both local and long-distance calls can be transmitted. When activated, the dialer instantly begins calling the numbers in sequence, delivering each message 1 to 3 times in a row, in accordance with the pre-selected number of dialing attempts.

The AD-2000 is extensively programmable, offering personalized customization to fulfill virtually any residential or business requirement. Plain-English prompts walk the user through the process in a timely manner.

Programming options abound, allowing the user to:

- Store up to 8 telephone/pager numbers.
- Choose 1-9 calling efforts for the numbers dialed.
- Select 1-3 message repeats.
- Record a variable combination (maximum: 7) of instructional outgoing messages (total elapsed time: 51 seconds).

Program up to 4 separate input channels with individually enable/disable, entry/exit delay and activation options (Normally Open (N.O.), Normally Closed (N.C.))

(dry contact or voltage activation) including momentary and continuous activation for each).

Further individualize each channel by selecting the delay times, telephone/pager numbers to be dialed and the specific outgoing messages to be played.

Please Familiarize Yourself With These Instructions Before Installation/Operation. This guide describes how to program and operate the dialer. We strongly recommend that you read the entire manual before attempting to use the unit.

To enhance ease of programming and operation, this guide includes:

- A Programming Sample/Quick Setup review on page 13 with a corresponding Program Planner.
- A Blank Program Planner on page 14. One copy of this Planner should be kept in a safe place by the end user. A separate copy should also be retained by the installer.

We are happy to provide a full measure of security reassurance and peace of mind with the Model AD-2000. For information about other innovative United Security Products equipment, call (800) 227-1592.

For Technical Service and Support, call: 858-413-0149 or Fax: 858-413-0124
You may also contact us via e-mail: usp@unitedsecurity.com
Technical Support is available Monday - Friday 6:30 a.m. to 4:30 P.M. PST

SPECIFICATIONS

Dimensions

Power source:	9-18VDC
Current (OPERATE mode - standby):	28mA typical.
Current (OPERATE mode - dialing):	100mA max.
Activation:	1) N.C. Activation: dialer activates when an "open" is detected 2) N.O. Activation: dialer activates when a "close" is detected 3) Voltage Activation: N.C. (applied voltage: Min. +5VDC. Max. +28VDC) N.O. (loss of continuous voltage: Min. 0VDC. Max. 0.25VDC)
Max. digits for outgoing numbers:	50
Operating temperature range:	-18 to 55 C (0 to 130 F)
Dimensions (inches):	6 x 4 x 1.5 in
Weight (ounces):	10 oz
Mounting:	Wall or Flat Surface
Case Material:	ABS
Color:	White
Warranty:	1 Year

Note: Design and specifications subject to change without notice.

DIALER ACCESSORIES

Power Source

AC-1: AC/DC Adaptor

Plugs into regular 110VAC outlet to provide the dialer with the required primary power.

AC-2: AC/DC Adaptor

12VDC/0.5A for stand alone with siren use.

PP-1: Power (Rechargeable)

Provides 24 (est.) hours of backup standby power.

AC-1P: AC/DC Adaptor For Use With PP-1

Plugs into regular 110VAC outlet to provide the dialer with the required primary power and additional input for PP-1 interface.

IR-1: Isolation Relay

Converts alarm output voltage to N.C. to provide clean input trigger to dialer.

Industrial/Residential Sensors

F20: Temperature Supervisory Switch <40 F

WLS: Water Level Sensor

RTS: Adjustable Temperature Controller, N.O., N.C.

PLS: Power Loss Sensor (110VAC)

Sensors

Magnetic Contacts - Door and Window
Glass Break Detectors
Hold Up Buttons/Emergency Switches
Pressure Mats - Sealed and Under Carpet
Motion Detectors

Siren

S-120: 2" Mini Siren, 12VDC @ 120 mA typical

Additional Options

24V Application: AD-2000/F

For this option the dialer is configured to operate at 24VDC to 32VDC max. All other specifications apply.

NOTE: CALL UNITED SECURITY PRODUCTS FOR ADDITIONAL INFORMATION AND DEVICES NOT LISTED HERE.

at you still have questions or need assistance, please contact our
Service Department between the hours of 7:30 AM and 4:00
PM, PST, Monday through Friday.

Federal Communications Commission Radio And Television Interference Statement For A Class 'B' Device

This equipment generates and uses radio frequency energy and if not installed and used properly, that is, in strict accordance

United Security Products
Issue date: 4/27/98

BID BOND

KNOW ALL MEN BY THESE PRESENTS, That we, the undersigned, A. J. Smith, Inc. dba Capital Builders, Inc.
of Huntington, WV, as Principal, and United States Surety Company
of Timonium, MD, a corporation organized and existing under the laws of the State of
MD with its principal office in the City of Timonium, as Surety, are held and firmly bound unto the State
of West Virginia, as Obligee, in the penal sum of Five Percent of Amount Bid (\$ 5%) for the payment of which,
well and truly to be made, we jointly and severally bind ourselves, our heirs, administrators, executors, successors and assigns.

The Condition of the above obligation is such that whereas the Principal has submitted to the Purchasing Section of the
Department of Administration a certain bid or proposal, attached hereto and made a part hereof, to enter into a contract in writing for
RFQ #DNR210080 - Chief Logan Recreation Center - CCTV, Security, and Access Control System - According to
Plans & Specifications

NOW THEREFORE,

(a) If said bid shall be rejected, or
(b) If said bid shall be accepted and the Principal shall enter into a contract in accordance with the bid or proposal attached
hereto and shall furnish any other bonds and insurance required by the bid or proposal, and shall in all other respects perform the
agreement created by the acceptance of said bid, then this obligation shall be null and void, otherwise this obligation shall remain in full
force and effect. It is expressly understood and agreed that the liability of the Surety for any and all claims hereunder shall, in no event,
exceed the penal amount of this obligation as herein stated.

The Surety, for the value received, hereby stipulates and agrees that the obligations of said Surety and its bond shall be in no
way impaired or affected by any extension of the time within which the Obligee may accept such bid, and said Surety does hereby
waive notice of any such extension.

IN WITNESS WHEREOF, Principal and Surety have hereunto set their hands and seals, and such of them as are corporations
have caused their corporate seals to be affixed hereunto and these presents to be signed by their proper officers, this
14th day of January, 2010.

Principal Corporate Seal

A. J. Smith, Inc. dba Capital Builders, Inc.
(Name of Principal)

By B. J. Burgess
(Must be President or
Vice President)

B.J. Burgess President
(Title)

Surety Corporate Seal

United States Surety Company
(Name of Surety)

By: Patricia A. Moye
Patricia A. Moye, WV Resident Agent Attorney in fact

IMPORTANT – Surety executing bonds must be licensed in West Virginia to transact surety insurance. Corporate seals must be affixed,
and a power of attorney must be attached.

POWER OF ATTORNEY

AMERICAN CONTRACTORS INDEMNITY COMPANY UNITED STATES SURETY COMPANY U.S. SPECIALTY INSURANCE COMPANY

KNOW ALL MEN BY THESE PRESENTS: That American Contractors Indemnity Company, a California corporation, United States Surety Company, a Maryland corporation, and U.S. Specialty Insurance Company, a Texas corporation (collectively, the "Companies"), do by these presents make, constitute and appoint: Gregory T. Gordon, Larry D. Kerr, Allan L. McVey, Patricia A. Moye, Kimberly J. Wilkinson

its true and lawful Attorney(s)-in-fact, each in their separate capacity if more than one is named above, with full power and authority hereby conferred in its name, place and stead, to execute, acknowledge and deliver any and all bonds, recognizances, undertakings or other instruments or contracts of suretyship to include riders, amendments, and consents of surety. This Power of Attorney is granted under and by authority of the following resolutions adopted by the Boards of Directors of the Companies:

Be it Resolved, that the President, any Vice-President, any Assistant Vice-President, any Secretary or any Assistant Secretary shall be and is hereby vested with full power and authority to appoint any one or more suitable persons as Attorney(s)-in-Fact to represent and act for and on behalf of the Company subject to the following provisions:

Attorney-in-Fact may be given full power and authority for and in the name of and on behalf of the Company, to execute, acknowledge and deliver, any and all bonds, recognizances, contracts, agreements or indemnity and other conditional or obligatory undertakings and any and all notices and documents canceling or terminating the Company's liability thereunder, and any such instruments so executed by any such Attorney-in-Fact shall be binding upon the Company as if signed by the President and sealed and effected by the Corporate Secretary.

Be it Resolved, that the signature of any authorized officer and seal of the Company heretofore or hereafter affixed to any power of attorney or any certificate relating thereto by facsimile, and any power of attorney or certificate bearing facsimile signature or facsimile seal shall be valid and binding upon the Company with respect to any bond or undertaking to which it is attached.

IN WITNESS WHEREOF, the Companies have caused this instrument to be signed and their corporate seals to be hereto affixed, this 25th day of July, 2008.

AMERICAN CONTRACTORS INDEMNITY COMPANY UNITED STATES SURETY COMPANY U.S. SPECIALTY INSURANCE COMPANY Corporate Seals



By: [Signature] Peter W. Carman, Vice President

State of Maryland County of Baltimore SS:

On this 4th day of December, 2008, before me, Jean Grzymala, a notary public, personally appeared Peter W. Carman, Vice President of American Contractors Indemnity Company, United States Surety Company and U.S. Specialty Insurance Company who proved to me on the basis of satisfactory evidence to be the person whose name is subscribed to the within instrument and acknowledged to me that he executed the same in his authorized capacity, and that by his signature on the instrument the person(s), or the entity upon behalf of which the person(s) acted, executed the instrument.

I certify under PENALTY OF PERJURY under the laws of the State of Maryland that the foregoing paragraph is true and correct. WITNESS my hand and official seal.

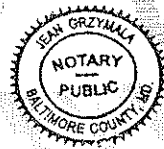

Signature [Signature] My commission expires the 15th day of December, 2012

I, Carol T. Nevin, Assistant Secretary of American Contractors Indemnity Company, United States Surety Company and U.S. Specialty Insurance Company, do hereby certify that the above and foregoing is a true and correct copy of a Power of Attorney, executed by said Companies, which is still in full force and effect; furthermore, the resolutions of the Boards of Directors, set out in the Power of Attorney are in full force and effect.

In Witness Whereof, I have hereunto set my hand and affixed the seals of said Companies at Baltimore, Maryland this 14th day of January, 2010. [Signature] Carol T. Nevin, Assistant Secretary



BID BOND PREPARATION INSTRUCTIONS

AGENCY _____ (A)
RFQ/RFP# _____ (B)

- (A) WV State Agency
(Stated on Page 1 "Spending Unit")
Request for Quotation Number (upper
right corner of page #1)
- (C) Your Company Name
- (D) City, Location of your Company
- (E) State, Location of your Company
- (F) Surety Corporate Name
- (G) City, Location of Surety
- (H) State, Location of Surety
- (I) State of Surety Incorporation
- (J) City of Surety Incorporation
- (K) Minimum amount of acceptable bid
bond is 5% of total bid. You may state
"5% of bid" or a specific amount on
this line in words.
- (L) Amount of bond in figures
- (M) Brief Description of scope of work
- (N) Day of the month
- (O) Month
- (P) Year
- (Q) Name of Corporation
- (R) Raised Corporate Seal of Principal
- (S) Signature of President or Vice
President
- (T) Title of person signing
- (U) Raised Corporate Seal of Surety
- (V) Corporate Name of Surety
- (W) Signature of Attorney in Fact of the
Surety

NOTE: Dated, Power of Attorney with Raised
Surety Seal must accompany this bid
bond.

Bid Bond

KNOW ALL MEN BY THESE PRESENTS, That we, the undersigned,
_____ (C) of _____ (D), _____ (E)
as Principal, and _____ (F) of _____ (G),
_____ (H), a corporation organized and existing under the laws
of the State of _____ (I) with its principal office in the City of
_____ (J), as Surety, are held and firmly bound unto The State
of West Virginia, as Obligee, in the penal sum of _____ (K)
(\$ _____ (L)) for the payment of which, well and truly to be made,
we jointly and severally bind ourselves, our heirs, administrators, executors,
successors and assigns.

The Condition of the above obligation is such that whereas the Principal
has submitted to the Purchasing Section of the Department of Administration
a certain bid or proposal, attached hereto and made a part hereof to enter into a
contract in writing for _____

_____ (M)

NOW THEREFORE.

(a) If said bid shall be rejected, or
(b) If said bid shall be accepted and the Principal shall enter into a
contract in accordance with the bid or proposal attached hereto and shall furnish
any other bonds and insurance required by the bid or proposal, and shall in all
other respects perform the agreement created by the acceptance of said bid then
this obligation shall be null and void, otherwise this obligation shall remain in full
force and effect. It is expressly understood and agreed that the liability of the
Surety for any and all claims hereunder shall, in no event, exceed the penal
amount of this obligation as herein stated

The Surety for value received, hereby stipulates and agrees that the
obligations of said Surety and its bond shall be in no way impaired or affected by
any extension of time within which the Obligee may accept such bid: and said
Surety does hereby waive notice of any such extension.

IN WITNESS WHEREOF, Principal and Surety have hereunto set their
hands and seals, and such of them as are corporations have caused their corporate
seals to be affixed hereto and these presents to be signed by their proper officers,
this _____ (N) day of _____ (O), 20 _____ (P).

Principal Corporate Seal

(R)

(U)
Surety Corporate Seal

_____ (Q)
(Name of Principal)
By _____ (S)
(Must be President or
Vice President)
_____ (T)
Title

(V)
(Name of Surety)

(W)
Attorney-in-Fact

IMPORTANT – Surety executing bonds must be licensed in West Virginia to
transact surety insurance. Raised Corporate Seals must be affixed and a Power of
Attorney must be attached.



State of West Virginia
DRUG FREE WORKPLACE CONFORMANCE AFFIDAVIT
West Virginia Code §21-1D-5

STATE OF WEST VIRGINIA

COUNTY OF WAYNE, TO-WIT:

I, B. J. BURGESS, after being first duly sworn, depose and state as follows:

- 1. I am an employee of A.J. SMITH, INC. DBA CAPITAL BUILDERS; and,
2. I do hereby attest that A.J. SMITH, INC. DBA CAPITAL BUILDERS

maintains a valid written drug free workplace policy and that such policy is in compliance with West Virginia Code §21-1D-5.

The above statements are sworn to under the penalty of perjury.

A.J. SMITH, INC. DBA CAPITAL BUILDERS
(Company Name)

By: B. J. Burgess
B. J. BURGESS
Title: PRESIDENT

Date: 01/14/2010

Taken, subscribed and sworn to before me this 14th day of JANUARY, 2010.

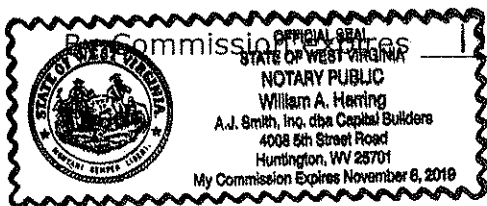

1/6/2019

Will A. Herring
(Notary Public)

THIS AFFIDAVIT MUST BE SUBMITTED WITH THE BID IN ORDER TO COMPLY WITH WV CODE PROVISIONS. FAILURE TO INCLUDE THE AFFIDAVIT WITH THE BID SHALL RESULT IN DISQUALIFICATION OF THE BID.

STATE OF WEST VIRGINIA
Purchasing Division

PURCHASING AFFIDAVIT

West Virginia Code §5A-3-10a states: No contract or renewal of any contract may be awarded by the state or any of its political subdivisions to any vendor or prospective vendor when the vendor or prospective vendor or a related party to the vendor or prospective vendor is a debtor and the debt owned is an amount greater than one thousand dollars in the aggregate

DEFINITIONS:

"Debt" means any assessment, premium, penalty, fine, tax or other amount of money owed to the state or any of its political subdivisions because of a judgment, fine, permit violation, license assessment, defaulted workers' compensation premium, penalty or other assessment presently delinquent or due and required to be paid to the state or any of its political subdivisions, including any interest or additional penalties accrued thereon.

"Debtor" means any individual, corporation, partnership, association, Limited Liability Company or any other form or business association owing a debt to the state or any of its political subdivisions. "Political subdivision" means any county commission; municipality; county board of education; any instrumentality established by a county or municipality; any separate corporation or instrumentality established by one or more counties or municipalities, as permitted by law; or any public body charged by law with the performance of a government function or whose jurisdiction is coextensive with one or more counties or municipalities. "Related party" means a party, whether an individual, corporation, partnership, association, limited liability company or any other form or business association or other entity whatsoever, related to any vendor by blood, marriage, ownership or contract through which the party has a relationship of ownership or other interest with the vendor so that the party will actually or by effect receive or control a portion of the benefit, profit or other consideration from performance of a vendor contract with the party receiving an amount that meets or exceeds five percent of the total contract amount.

EXCEPTION: The prohibition of this section does not apply where a vendor has contested any tax administered pursuant to chapter eleven of this code, workers' compensation premium, permit fee or environmental fee or assessment and the matter has not become final or where the vendor has entered into a payment plan or agreement and the vendor is not in default of any of the provisions of such plan or agreement.

Under penalty of law for false swearing (*West Virginia Code §61-5-3*), it is hereby certified that the vendor affirms and acknowledges the information in this affidavit and is in compliance with the requirements as stated.

WITNESS THE FOLLOWING SIGNATURE

Vendor's Name: A.J. Smith, Inc. dba Capital Builders

Authorized Signature: *b. j. buyers* Date: 01/14/2010

State of West Virginia

County of Wayne, to-wit:

Taken, subscribed, and sworn to before me this 14th day of January, 2010.

My Commission expires 11/06, 2019.

AFFIX SEAL HERE

NOTARY PUBLIC *Will A. Herring*

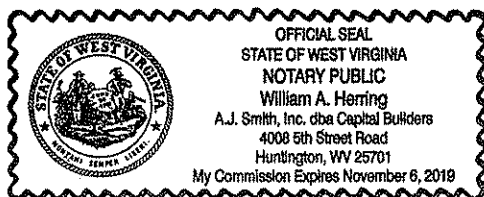

CONTRACTOR LICENSE

Authorized by the

West Virginia Contractor Licensing Board

Number: WV032728

Classification:

GENERAL BUILDING

A J SMITH INC
DBA CAPITAL BUILDERS
4008 5TH STREET RD
HUNTINGTON, WV 25701-9545

Date Issued

Expiration Date

JULY 09 2009	JULY 09 2010
--------------	--------------

Bunde R. Slawer

Authorized Company Signature

Michael A. Carl

Chair, West Virginia Contractor
Licensing Board

**WEST VIRGINIA
CONTRACTOR
LICENSING
BOARD**

This license, or a copy thereof, must be posted in a conspicuous place at every construction site where work is being performed. This license number must appear in all advertisements, on all bid submissions and on all fully executed and binding contracts. This license cannot be assigned or transferred by licensee. Issued under provisions of West Virginia Code, Chapter 21, Article 11.

ACORD CERTIFICATE OF LIABILITY INSURANCE

DATE (MM/DD/YY)
04/15/09

PRODUCER
Peoples Insurance Agency, Inc.
dba Putnam Insurance Agency
101 Fifth Ave, PO Box 2388
Huntington WV 25724-2388

Clarence C. Massey
Phone No. 304-522-6555 Fax No. 304-522-6563

INSURED

AJ Smith Inc
4008 5th Street Road
Huntington WV 25701-9545

THIS CERTIFICATE IS ISSUED AS A MATTER OF INFORMATION ONLY AND CONFERS NO RIGHTS UPON THE CERTIFICATE HOLDER. THIS CERTIFICATE DOES NOT AMEND, EXTEND OR ALTER THE COVERAGE AFFORDED BY THE POLICIES BELOW.

COMPANIES AFFORDING COVERAGE

COMPANY A Brick Street Insurance

COMPANY B

COMPANY C

COMPANY D

THIS IS TO CERTIFY THAT THE POLICIES OF INSURANCE LISTED BELOW HAVE BEEN ISSUED TO THE INSURED NAMED ABOVE FOR THE POLICY PERIOD INDICATED, NOTWITHSTANDING ANY REQUIREMENT, TERM OR CONDITION OF ANY CONTRACT OR OTHER DOCUMENT WITH RESPECT TO WHICH THIS CERTIFICATE MAY BE ISSUED OR MAY PERTAIN, THE INSURANCE AFFORDED BY THE POLICIES DESCRIBED HEREIN IS SUBJECT TO ALL THE TERMS, EXCLUSIONS AND CONDITIONS OF SUCH POLICIES. LIMITS SHOWN MAY HAVE BEEN REDUCED BY PAID CLAIMS.

CO LTR	TYPE OF INSURANCE	POLICY NUMBER	POLICY EFFECTIVE DATE (MM/DD/YY)	POLICY EXPIRATION DATE (MM/DD/YY)	LIMITS
	GENERAL LIABILITY <input type="checkbox"/> COMPREHENSIVE FORM <input type="checkbox"/> PREMISES/OPERATIONS <input type="checkbox"/> UNDERGROUND EXPLOSION & COLLAPSE HAZARD <input type="checkbox"/> PRODUCTS/COMPLETED OPER <input type="checkbox"/> CONTRACTUAL <input type="checkbox"/> INDEPENDENT CONTRACTORS <input type="checkbox"/> BROAD FORM PROPERTY DAMAGE <input type="checkbox"/> PERSONAL INJURY				BODILY INJURY OCC \$ BODILY INJURY AGG \$ PROPERTY DAMAGE OCC \$ PROPERTY DAMAGE AGG \$ BI & PD COMBINED OCC \$ BI & PD COMBINED AGG \$ PERSONAL INJURY AGG \$
	AUTOMOBILE LIABILITY <input type="checkbox"/> ANY AUTO <input type="checkbox"/> ALL OWNED AUTOS (Private Pass) <input type="checkbox"/> ALL OWNED AUTOS (Other than Private Passenger) <input type="checkbox"/> HIRED AUTOS <input type="checkbox"/> NON-OWNED AUTOS <input type="checkbox"/> GARAGE LIABILITY				BODILY INJURY (Per person) \$ BODILY INJURY (Per accident) \$ PROPERTY DAMAGE \$ BODILY INJURY & PROPERTY DAMAGE COMBINED \$
	EXCESS LIABILITY <input type="checkbox"/> UMBRELLA FORM <input type="checkbox"/> OTHER THAN UMBRELLA FORM				EACH OCCURRENCE \$ AGGREGATE \$
A	WORKERS COMPENSATION AND EMPLOYERS' LIABILITY THE PROPRIETOR/PARTNERS/EXECUTIVE OFFICERS ARE: <input type="checkbox"/> INCL <input type="checkbox"/> EXCL	WC10039658-06	04/05/09	04/05/10	<input checked="" type="checkbox"/> WC STATUTORY LIMITS <input type="checkbox"/> OTHER EL EACH ACCIDENT \$ 100,000 EL DISEASE - POLICY LIMIT \$ 500,000 EL DISEASE - EA EMPLOYEE \$ 100,000
	OTHER				

DESCRIPTION OF OPERATIONS/LOCATIONS/VEHICLES/SPECIAL ITEMS
EVIDENCE OF WEST VIRGINIA WORKERS COMPENSATION INSURANCE.

EVIDENCE OF INSURANCE

SHOULD ANY OF THE ABOVE DESCRIBED POLICIES BE CANCELLED BEFORE THE EXPIRATION DATE THEREOF, THE ISSUING COMPANY WILL ENDEAVOR TO MAIL 30 DAYS WRITTEN NOTICE TO THE CERTIFICATE HOLDER NAMED TO THE LEFT, BUT FAILURE TO MAIL SUCH NOTICE SHALL IMPOSE NO OBLIGATION OR LIABILITY OF ANY KIND UPON THE COMPANY, ITS AGENTS OR REPRESENTATIVES.

AUTHORIZED REPRESENTATIVE
Ronda Hutchinson

2009

**WEST VIRGINIA
STATE TAX DEPARTMENT**

2011

**BUSINESS REGISTRATION
CERTIFICATE**

ISSUED TO:
**A J SMITH INC
DBA CAPITAL BUILDERS
4008 5TH STREET RD
HUNTINGTON, WV 25701-9545**

BUSINESS REGISTRATION ACCOUNT NUMBER: 1043-2500

This certificate is issued for the registration period beginning: **July 1, 2009**

This certificate is valid until: **June 30, 2011**

*This business registration certificate is issued by
the West Virginia State Tax Commissioner
in accordance with Chapter 11, Article 12 of the West Virginia Code.*

*The person or organization identified on this certificate is registered
to conduct business in the State of West Virginia at the location above.*

This certificate is not transferrable and must be displayed at the location for which issued.

**ENGAGING IN BUSINESS WITHOUT CONSPICUOUSLY POSTING A WEST VIRGINIA BUSINESS
REGISTRATION CERTIFICATE IN THE PLACE OF BUSINESS IS A CRIME AND MAY SUBJECT YOU
TO FINES PER W. VA. CODE § 11-9.**

**TRAVELING/STREET VENDORS: Must carry a copy of this certificate in every vehicle operated by them.
CONTRACTORS, DRILLING OPERATORS, TIMBER/LOGGING OPERATIONS: Must have a copy of
this certificate displayed at every job site within West Virginia.**



State of West Virginia

BUREAU OF EMPLOYMENT PROGRAMS

CHARLESTON, WEST VIRGINIA APRIL 13, 2004

THIS IS TO CERTIFY THAT

A.J. SMITH, INC., DBA
CAPITAL BUILDERS, INC.

OF

HUNTINGTON, WV

HAS BEEN REGISTERED WITH THE WEST VIRGINIA BUREAU OF
EMPLOYMENT PROGRAMS AS AN EMPLOYER UNDER THE
PROVISIONS OF THE WEST VIRGINIA UNEMPLOYMENT
COMPENSATION LAW AND HAS BEEN ASSIGNED THE ACCOUNT
NUMBER 000040620-1

A handwritten signature in cursive script, reading "Luetta Muzzelle".

Acting Commissioner