



**State of West Virginia
Department of Administration
Purchasing Division**

NOTICE

Due to the size of this bid, it was impractical to scan every page for online viewing. We have made an attempt to scan and publish all pertinent bid information. However, it is important to note that some pages were necessarily omitted.

If you would like to review the bid in its entirety, please contact the buyer. Thank you.



Little Tikes Commercial Equipment
 Jim Benedict P O 1494
 1607 East Market Street
 Charlottesville, VA. 22902
 jim@vaplaygrounds.com
 434 249 2158 (cell)
 434 296 3289 (fax)



KRISTA FERRELL #21

Frank Whittaker
 Purchasing Division
 State of West Virginia.
 Department of Administration
 2019 Washington St.
 Charleston, WV 25305

RECEIVED

2009 AUG 10 P 3:34

PURCHASING DIVISION
 STATE OF WV

RE. DNR Playground RFP

To whom it may concern,

This letter and supporting bid documents represent our reply and price quote for the DNR Playground RFP for the referenced park site. We are quoting "as equal and better" to the specifications and item list indicated in this RFP. Our product is manufactured by Little Tikes Commercial factory, hereafter "LIC". This bid is offered by the factory by and thru the local WV agent. We state that we comply fully with all requirements for ASTM 1487 and CPSC 325 and ADA and IPEMA third party guidelines. We have attempted to meet the specifications and stated requirements and drawings showing play events. Plan views and 3D renderings are attached. Our actual items list has been notated to indicate our intended "as equal and better" LTC equipment in place of vendor named in specs. Our post system is 5.5 inch OD uprights. Our swing arch posts are 5 inch OD and the support beam is 3.5 inch OD. Our Attachments are direct bolt. Our posts are 5.5 inch steel, prepared and powder coated in the colors requested. Some upright posts are not aluminum, but are heavy duty OD diameter steel, and powder coated steel with extra epoxy coating. Our posts offer 100 year warranty against defects. Recent equipment industry standards recommend this heavy duty steel in order to meet the demand for strength, durability, and low maintenance over time. We ask you to please review all attachments in support of our full compliance for this RFP.

With regards,

M James Benedict, agent
 Va Playground Services and LTC

NOTE

I-SWING
 INCLUSIVE SEAT
 DURAGLOE SEAT

BY LITTLE TIKES

AS EQUAL BID

LARGE ROCK
 SMALL MEDIUM ROCK

BY DYNAMO ROCKS
 BY DYNAMO ROCKS

6 each FOSSIL IMPRINTS ON THESE BOULDERS
 GLASS FIBRE REINFORCED CONCRETE
 MATERIAL IS GFRG OVER STEEL FRAME



State of West Virginia
 Department of Administration
 Purchasing Division
 2019 Washington Street East
 Post Office Box 50130
 Charleston, WV 25305-0130

Request for Quotation

RFO NUMBER
DNR210017

PAGE
1

ADDRESS CORRESPONDENCE TO ATTENTION OF:
KRISTA FERRELL
804-558-2596

VENDOR

*A09113539 804-798-6842
 VIRGINIA PLAYGROUND SERVICES I
 14276 RIVERSIDE DR
 ASHLAND VA 23005

SHIP TO

DIVISION OF NATURAL RESOURCES
 PINNACLE ROCK STATE PARK
 ATTN: PARK SUPERINTENDENT
 POST OFFICE BOX 704
 BLUEFIELD, WV 24701 589-5307

DATE PRINTED	TERMS OF SALE	SHIP VIA	F.O.B.	FREIGHT TERMS
07/23/2009				

BID OPENING DATE: 08/11/2009 BID OPENING TIME 01:30PM

LINE	QUANTITY	UOP	CAT NO.	ITEM NUMBER	UNIT PRICE	AMOUNT
0001	1	LS		650-38		\$ 27,700.00
PLAYGROUND EQUIPMENT (NOT OTHERWISE CLASSIFIED)						
REQUEST FOR QUOTATION (RFQ)						
THE WEST VIRGINIA STATE PURCHASING DIVISION FOR THE AGENCY, THE WEST VIRGINIA DIVISION OF NATURAL RESOURCES, IS SOLICITING BIDS TO PROVIDE PLAYGROUND EQUIPMENT FOR PINNACLE ROCK STATE PARK LOCATED IN BRAMWELL, WEST VIRGINIA PER THE ATTACHED SPECIFICATIONS.						
NO INSTALLATION IS REQUIRED.						
TECHNICAL QUESTIONS CONCERNING THIS PROJECT MUST BE SUBMITTED TO FRANK WHITTAKER IN THE WEST VIRGINIA STATE PURCHASING DIVISION VIA FAX AT 304-558-4115 OR VIA EMAIL AT FRANK.M.WHITTAKER@WV.GOV. DEADLINE FOR ALL TECHNICAL QUESTIONS IS JULY 30, 2009 AT THE CLOSE OF BUSINESS. ALL TECHNICAL QUESTIONS RECEIVED, IF ANY, WILL BE ANSWERED BY ADDENDUM AFTER THE DEADLINE HAS LAPSED.						
QUESTIONS CONCERNING THE PROCESS BY WHICH A VENDOR MAY SUBMIT A BID TO THE STATE OF WEST VIRGINIA ARE NOT CONSIDERED TO BE TECHNICAL QUESTIONS AND MAY BE SUBMITTED AT ANY TIME PRIOR TO THE BID OPENING AND IN ANY FORMAT.						
THE MODEL/BRAND/SPECIFICATIONS NAMED HEREIN ESTABLISH						

SIGNATURE <i>James Bevel</i>				SEE REVERSE SIDE FOR TERMS AND CONDITIONS	
TITLE <i>AGENT</i>		FEIN <i>20-4869487</i>	TELEPHONE <i>304-2492158</i>	DATE <i>8-10-09</i>	ADDRESS CHANGES TO BE NOTED ABOVE

WHEN RESPONDING TO RFQ, INSERT NAME AND ADDRESS IN SPACE ABOVE LABELED 'VENDOR'

GENERAL TERMS & CONDITIONS
REQUEST FOR QUOTATION (RFQ) AND REQUEST FOR PROPOSAL (RFP)

1. Awards will be made in the best interest of the State of West Virginia.
2. The State may accept or reject in part, or in whole, any bid.
3. All quotations are governed by the *West Virginia Code* and the *Legislative Rules* of the Purchasing Division.
4. Prior to any award, the apparent successful vendor must be properly registered with the Purchasing Division and have paid the required \$125 fee.
5. All services performed or goods delivered under State Purchase Order/Contracts are to be continued for the term of the Purchase Order/Contracts, contingent upon funds being appropriated by the Legislature or otherwise being made available. In the event funds are not appropriated or otherwise available for these services or goods, this Purchase Order/Contract becomes void and of no effect after June 30.
6. Payment may only be made after the delivery and acceptance of goods or services.
7. Interest may be paid for late payment in accordance with the *West Virginia Code*.
8. Vendor preference will be granted upon written request in accordance with the *West Virginia Code*.
9. The State of West Virginia is exempt from federal and state taxes and will not pay or reimburse such taxes.
10. The Director of Purchasing may cancel any Purchase Order/Contract upon 30 days written notice to the seller.
11. The laws of the State of West Virginia and the *Legislative Rules* of the Purchasing Division shall govern all rights and duties under the Contract, including without limitation the validity of this Purchase Order/Contract.
12. Any reference to automatic renewal is hereby deleted. The Contract may be renewed only upon mutual written agreement of the parties.
13. **BANKRUPTCY:** In the event the vendor/contractor files for bankruptcy protection, the State may deem this contract null and void, and terminate such contract without further order.
14. **HIPAA BUSINESS ASSOCIATE ADDENDUM:** The West Virginia State Government HIPAA Business Associate Addendum (BAA), approved by the Attorney General, and available online at the Purchasing Division's web site (<http://www.state.wv.us/admin/purchase/vrc/hipaa.htm>) is hereby made part of the agreement. Provided that, the Agency meets the definition of a Cover Entity (45 CFR §160.103) and will be disclosing Protected Health Information (45 CFR §160.103) to the vendor.
15. **WEST VIRGINIA ALCOHOL & DRUG-FREE WORKPLACE ACT:** If this Contract constitutes a public improvement construction contract as set forth in Article 1D, Chapter 21 of the West Virginia Code ("The West Virginia Alcohol and Drug-Free Workplace Act"), then the following language shall hereby become part of this Contract: "The contractor and its subcontractors shall implement and maintain a written drug-free workplace policy in compliance with the West Virginia Alcohol and Drug-Free Workplace Act, as set forth in Article 1D, Chapter 21 of the West Virginia Code. The contractor and its subcontractors shall provide a sworn statement in writing, under the penalties of perjury, that they maintain a valid drug-free work place policy in compliance with the West Virginia and Drug-Free Workplace Act. It is understood and agreed that this Contract shall be cancelled by the awarding authority if the Contractor: 1) Fails to implement its drug-free workplace policy; 2) Fails to provide information regarding implementation of the contractor's drug-free workplace policy at the request of the public authority; or 3) Provides to the public authority false information regarding the contractor's drug-free workplace policy."

INSTRUCTIONS TO BIDDERS

1. Use the quotation forms provided by the Purchasing Division.
2. **SPECIFICATIONS:** Items offered must be in compliance with the specifications. Any deviation from the specifications must be clearly indicated by the bidder. Alternates offered by the bidder as **EQUAL** to the specifications must be clearly defined. A bidder offering an alternate should attach complete specifications and literature to the bid. The Purchasing Division may waive minor deviations to specifications.
3. Complete all sections of the quotation form.
4. Unit prices shall prevail in case of discrepancy.
5. All quotations are considered F.O.B. destination unless alternate shipping terms are clearly identified in the quotation.
6. **BID SUBMISSION:** All quotations must be delivered by the bidder to the office listed below prior to the date and time of the bid opening. Failure of the bidder to deliver the quotations on time will result in bid disqualifications: Department of Administration, Purchasing Division, 2019 Washington Street East, P.O. Box 50130, Charleston, WV 25305-0130.



State of West Virginia
 Department of Administration
 Purchasing Division
 2019 Washington Street East
 Post Office Box 50130
 Charleston, WV 25305-0130

Request for Quotation

RFQ NUMBER
 DNR210017

PAGE
 2

ADDRESS CORRESPONDENCE TO ATTENTION OF:
 KRISTA FERRELL
 804-558-2596

VENDOR

*A09113539 804-798-6842
 VIRGINIA PLAYGROUND SERVICES I
 14276 RIVERSIDE DR
 ASHLAND VA 23005

SHIP TO

DIVISION OF NATURAL RESOURCES
 PINNACLE ROCK STATE PARK
 ATTN: PARK SUPERINTENDENT
 POST OFFICE BOX 704
 BLUEFIELD, WV
 24701 589-5307

DATE PRINTED	TERMS OF SALE	SHIP VIA	F.O.B.	FREIGHT TERMS
07/23/2009				

BID OPENING DATE: 08/11/2009 BID OPENING TIME 01:30PM

LINE	QUANTITY	UOP	CAT NO.	ITEM NUMBER	UNIT PRICE	AMOUNT
<p>THE ACCEPTABLE LEVEL OF QUALITY ONLY AND ARE NOT INTENDED TO REFLECT A PREFERENCE OR FAVOR ANY PARTICULAR BRAND OR VENDOR. VENDORS WHO ARE BIDDING ALTERNATES SHOULD SO STATE AND INCLUDE PERTINENT LITERATURE AND SPECIFICATIONS. FAILURE TO PROVIDE INFORMATION FOR ANY ALTERNATES MAY BE GROUNDS FOR REJECTION OF THE BID. THE STATE RESERVES THE RIGHT TO WAIVE MINOR IRREGULARITIES IN BIDS OR SPECIFICATIONS IN ACCORDANCE WITH SECTION 148-1-4 (F) OF THE WEST VIRGINIA LEGISLATIVE RULES AND REGULATIONS.</p> <p>CANCELLATION: THE DIRECTOR OF PURCHASING RESERVES THE RIGHT TO CANCEL THIS CONTRACT IMMEDIATELY UPON WRITTEN NOTICE TO THE VENDOR IF THE MATERIALS OR WORKMANSHIP SUPPLIED ARE OF AN INFERIOR QUALITY OR DO NOT CONFORM WITH THE SPECIFICATIONS OF THE BID AND CONTRACT HERE IN.</p> <p>EXHIBIT 10</p> <p>ADDENDUM ACKNOWLEDGEMENT</p> <p>I HEREBY ACKNOWLEDGE RECEIPT OF THE FOLLOWING CHECKED ADDENDUM(S) AND HAVE MADE THE NECESSARY REVISIONS TO MY PROPOSAL, PLANS AND/OR SPECIFICATION, ETC.</p> <p>ADDENDUM NOS. :</p> <p>NO. 1</p> <p>NO. 2</p> <p>NO. 3</p> <p>NO. 4</p> <p>NO. 5</p>						

SEE REVERSE SIDE FOR TERMS AND CONDITIONS

SIGNATURE _____ TELEPHONE _____ DATE _____

TITLE _____ FEIN _____ ADDRESS CHANGES TO BE NOTED ABOVE

WHEN RESPONDING TO RFQ, INSERT NAME AND ADDRESS IN SPACE ABOVE LABELED 'VENDOR'



State of West Virginia
 Department of Administration
 Purchasing Division
 2019 Washington Street East
 Post Office Box 50130
 Charleston, WV 25305-0130

Request for Quotation

RFQ NUMBER
 DNR210017

PAGE
 3

ADDRESS CORRESPONDENCE TO ATTENTION OF:
 KRISTA FERRELL
 804-558-2596

VENDOR

*A09113539 804-798-6842
 VIRGINIA PLAYGROUND SERVICES I
 14276 RIVERSIDE DR
 ASHLAND VA 23005

SHIP TO

DIVISION OF NATURAL RESOURCES
 PINNACLE ROCK STATE PARK
 ATTN: PARK SUPERINTENDENT
 POST OFFICE BOX 704
 BLUEFIELD, WV 24701 589-5307

DATE PRINTED	TERMS OF SALE	SHIP VIA	F.O.B.	FREIGHT TERMS
07/23/2009				

BID OPENING DATE: 08/11/2009 BID OPENING TIME 01:30PM

LINE	QUANTITY	UOP	CAT NO.	ITEM NUMBER	UNIT PRICE	AMOUNT
<p>I UNDERSTAND THAT FAILURE TO CONFIRM THE RECEIPT OF THE ADDENDUM(S) MAY BE CAUSE FOR REJECTION OF THE BIDS.</p> <p>VENDOR MUST CLEARLY UNDERSTAND THAT ANY VERBAL REPRESENTATION MADE OR ASSUMED TO BE MADE DURING ANY ORAL DISCUSSION HELD BETWEEN VENDOR'S REPRESENTATIVES AND ANY STATE PERSONNEL IS NOT BINDING. ONLY THE INFORMATION ISSUED IN WRITING AND ADDED TO THE SPECIFICATIONS BY AN OFFICIAL ADDENDUM IS BINDING.</p> <p><i>James Benedict</i> SIGNATURE VIRGINIA PLAYGROUND SERVICE COMPANY 8-10-09 DATE</p> <p>REV. 11/96</p> <p>BANKRUPTCY: IN THE EVENT THE VENDOR/CONTRACTOR FILES FOR BANKRUPTCY PROTECTION, THIS CONTRACT IS AUTOMATICALLY NULL AND VOID, AND IS TERMINATED WITHOUT FURTHER ORDER.</p> <p>REV. 1/2005</p> <p style="text-align: center;">NOTICE</p> <p>A SIGNED BID MUST BE SUBMITTED TO:</p> <p style="text-align: center;">DEPARTMENT OF ADMINISTRATION PURCHASING DIVISION BUILDING 15 2019 WASHINGTON STREET, EAST</p>						

SEE REVERSE SIDE FOR TERMS AND CONDITIONS

SIGNATURE	TELEPHONE	DATE
TITLE	FEIN	ADDRESS CHANGES TO BE NOTED ABOVE

WHEN RESPONDING TO RFQ, INSERT NAME AND ADDRESS IN SPACE ABOVE LABELED 'VENDOR'



State of West Virginia
 Department of Administration
 Purchasing Division
 2019 Washington Street East
 Post Office Box 50130
 Charleston, WV 25305-0130

Request for Quotation

RFQ NUMBER
 DNR210017

PAGE
 4

ADDRESS CORRESPONDENCE TO ATTENTION OF:
 KRISTA FERRELL
 804-558-2596

VENDOR

*A09113539 804-798-6842
 VIRGINIA PLAYGROUND SERVICES I
 14276 RIVERSIDE DR
 ASHLAND VA 23005

SHIP TO

DIVISION OF NATURAL RESOURCES
 PINNACLE ROCK STATE PARK
 ATTN: PARK SUPERINTENDENT
 POST OFFICE BOX 704
 BLUEFIELD, WV 24701 589-5307

DATE PRINTED	TERMS OF SALE	SHIP VIA	F.O.B.	FREIGHT TERMS
07/23/2009				

BID OPENING DATE: 08/11/2009 BID OPENING TIME 01:30PM

LINE	QUANTITY	UOP	CAT NO	ITEM NUMBER	UNIT PRICE	AMOUNT
				CHARLESTON, WV 25305-0130		
THE BID SHOULD CONTAIN THIS INFORMATION ON THE FACE OF THE ENVELOPE OR THE BID MAY NOT BE CONSIDERED: SEALED BID BUYER: KRISTA FERRELL-FILE 21 REQ. NO.: DNR210017 BID OPENING DATE: 08/11/2009 BID OPENING TIME: 1:30 PM PLEASE PROVIDE A FAX NUMBER IN CASE IT IS NECESSARY TO CONTACT YOU REGARDING YOUR BID: ----- 434-2963289 PLEASE PRINT OR TYPE NAME OF PERSON TO CONTACT CONCERNING THIS QUOTE: ----- JIM BENEDICT CELL 434 2492158 ***** THIS IS THE END OF RFQ DNR210017 ***** TOTAL: <u>\$27,700⁰⁰</u>						

SEE REVERSE SIDE FOR TERMS AND CONDITIONS

SIGNATURE	TELEPHONE	DATE
TITLE	FEIN	ADDRESS CHANGES TO BE NOTED ABOVE

WHEN RESPONDING TO RFQ, INSERT NAME AND ADDRESS IN SPACE ABOVE LABELED 'VENDOR'

Pinnacle Rock State Park Playground Specifications

To supply playground equipment at Pinnacle Rock State Park, Bramwell, West Virginia to offer play activities for children ages two (2) to twelve (12) Park personnel will install all playground equipment. The award may be split if it is in the best interest of the West Virginia Division of Natural Resources. All items must be F.O.B. Destination. Freight or delivery charges must be included in the price of the goods.

The playground components will include the following items:

ASEQUAL BY DYNAMO ROCKS

Cre8Play strato rock climber, Model #STRATO1, or equal. Climber must be a minimum of 8' in height and must have 360 degrees of climbing for children ages six (6) and up. Climber must have an ADA accessible feature and a minimum of five (5) 3D relief discovery fossils. Successful vendor must be able to match the color of the Pinnacle Rock to maintain park heritage. Climber must be composed of glass fiber reinforced concrete over structural steel frame.

ASEQUAL BY DYNAMO ROCKS

Cre8Play summit rock climber, Model #SUMMIT1, or equal. Climber must be a minimum of 3' in height and must have a minimum of 360 degrees of climbing for children ages two (2) to five (5). Successful vendor must be able to match the color of the Pinnacle Rock to maintain park heritage. Climber must be composed of glass fiber reinforced concrete over structural steel frame.

GameTime T-frame swing, Item #P831, or equal. Swing frame must be composed of aluminum or galvanized steel and a minimum 3 1/2" OD.

GameTime T-frame zero-G chair, Item #8555, or equal. Swing must include all hardware required for installation.

ASEQUAL

GameTime super seat-2, Item #1479. Swing must include all hardware required for installation.

T-SWING & SEATS by LITTLE TIKES
2 ea BOULDERS by DYNAMO ROCKS

Pinnacle Rock State Park Playground Specifications

All playground equipment must meet the following requirements:

- Compliance with U.S. Consumer Product Safety Commission, Handbook for Public Playground Safety
- Compliance with ASTM Standard F 1487
- Compliance with Architectural and Transportation Barriers Compliance Board, Americans with Disabilities Act (ADA) Accessibility Guidelines for Buildings and Facilities; Play Areas

Vendors must submit the following attachments:

- Complete manufacturer's parts specifications and warranties
- Layout drawing to scale of the proposed play structure or equipment
- ASTM and CPSC Statement of Compliance

Warranties:

- All equipment must be guaranteed to be free of defects in workmanship and material for a minimum of one year from date of acceptance. However, if manufacturer warranty periods are longer than the required minimum one year warranty, those warranties shall apply.

Color scheme of equipment must be coordinated with Pinnacle Rock State Park.

Pinnacle Rock State Park

PLAYGROUND EQUIPMENT SHEET

Please complete the below information concerning the brand(s) of equipment being bid in relation to this project. If bidding "or equal" brands, please attach manufacturer's literature documenting that it meets the mandatory requirements stated in the specifications. Vendors should note the areas of the provided manufacturer's literature that adheres to the mandatory requirements outlined in the Request For Proposal.

AS EQUAL BID < SWING = LITTLE TIKES FACTORY
ROCKS = DYNAMO INDUSTRIES FACTORY

Item No.	Equipment	Manufacturer	Model
1	Cre8Play Strato Rock Climber, Model #STRATO1, or equal.	DYNAMO INDUSTRIES	DX R01275-B
2	Cre8Play Summit Rock Climber, Model #SUMMIT1, or equal.	DYNAMO INDUSTRIES	DX R03122-B
3	GameTime T-frame swing, Item #P831, or equal.	LITTLE TIKES LTC	# 2012 T. FRAME
4	GameTime T-frame zero-G chair, Item #8555, or equal.	LITTLE TIKES ADA INCLUSIVE	# 200200332
5	GameTime super seat-2, Item #1479.	LITTLE TIKES DURA GLIDE	# 100100150

Pinnacle Rock State Park Playground Equipment
PRICING SHEET

Item No.	Quantity	Description	Unit Price	Amount
1	1	Cre8Play Strato Rock Climber, Model #STRATO1, or equal.	17700-	17,700 ⁰⁰
2	1	Cre8Play Summit Rock Climber, Model #SUMMIT1, or equal.	7900-	7900 ⁰⁰
3	1	GameTime T-frame swing, Item #P831, or equal.	1250-	1250-
4	1	GameTime T-frame zero-G chair, Item #8555, or equal.	700-	700-
5	1	GameTime super seat-2, Item #1479.	150-	150-
TOTAL				\$27,700⁰⁰

TWENTY SEVEN THOUSAND SEVEN HUNDRED DOLLARS

Vendors must provide unit costs for all line items shown above. Failure to provide line item pricing will result in the disqualification of the vendor's bid.

NOTE PRICES FOR TWO ROCKS ABOVE ASSUMES BOTH ROCKS SHIP ON ONE TRUCK FROM ORIGINAL FACTORY SO BOTH ROCKS PURCHASED TOGETHER IN ONE ORDER.

WJG 8-10-09

State of West Virginia

VENDOR PREFERENCE CERTIFICATE

Certification and application* is hereby made for Preference in accordance with West Virginia Code, §5A-3-37 (Does not apply to construction contracts) West Virginia Code, §5A-3-37, provides an opportunity for qualifying vendors to request (at the time of bid) preference for their residency status. Such preference is an evaluation method only and will be applied only to the cost bid in accordance with the West Virginia Code. This certificate for application is to be used to request such preference. The Purchasing Division will make the determination of the Resident Vendor Preference, if applicable.

- 1. Application is made for 2.5% resident vendor preference for the reason checked: Bidder is an individual resident vendor and has resided continuously in West Virginia for four (4) years immediately preceding the date of this certification; or, Bidder is a partnership, association or corporation resident vendor and has maintained its headquarters or principal place of business continuously in West Virginia for four (4) years immediately preceding the date of this certification; or 80% of the ownership interest of Bidder is held by another individual, partnership, association or corporation resident vendor who has maintained its headquarters or principal place of business continuously in West Virginia for four (4) years immediately preceding the date of this certification; or, Bidder is a nonresident vendor which has an affiliate or subsidiary which employs a minimum of one hundred state residents and which has maintained its headquarters or principal place of business within West Virginia continuously for the four (4) years immediately preceding the date of this certification; or,
2. Application is made for 2.5% resident vendor preference for the reason checked: Bidder is a resident vendor who certifies that, during the life of the contract, on average at least 75% of the employees working on the project being bid are residents of West Virginia who have resided in the state continuously for the two years immediately preceding submission of this bid; or,
3. Application is made for 2.5% resident vendor preference for the reason checked: Bidder is a nonresident vendor employing a minimum of one hundred state residents or is a nonresident vendor with an affiliate or subsidiary which maintains its headquarters or principal place of business within West Virginia employing a minimum of one hundred state residents who certifies that, during the life of the contract, on average at least 75% of the employees or Bidder's affiliate's or subsidiary's employees are residents of West Virginia who have resided in the state continuously for the two years immediately preceding submission of this bid; or,
4. Application is made for 5% resident vendor preference for the reason checked: Bidder meets either the requirement of both subdivisions (1) and (2) or subdivision (1) and (3) as stated above; or,
5. Application is made for 3.5% resident vendor preference who is a veteran for the reason checked: Bidder is an individual resident vendor who is a veteran of the United States armed forces, the reserves or the National Guard and has resided in West Virginia continuously for the four years immediately preceding the date on which the bid is submitted; or,
6. Application is made for 3.5% resident vendor preference who is a veteran for the reason checked: Bidder is a resident vendor who is a veteran of the United States armed forces, the reserves or the National Guard, if, for purposes of producing or distributing the commodities or completing the project which is the subject of the vendor's bid and continuously over the entire term of the project, on average at least seventy-five percent of the vendor's employees are residents of West Virginia who have resided in the state continuously for the two immediately preceding years.

Bidder understands if the Secretary of Revenue determines that a Bidder receiving preference has failed to continue to meet the requirements for such preference, the Secretary may order the Director of Purchasing to: (a) reject the bid; or (b) assess a penalty against such Bidder in an amount not to exceed 5% of the bid amount and that such penalty will be paid to the contracting agency or deducted from any unpaid balance on the contract or purchase order.

By submission of this certificate, Bidder agrees to disclose any reasonably requested information to the Purchasing Division and authorizes the Department of Revenue to disclose to the Director of Purchasing appropriate information verifying that Bidder has paid the required business taxes, provided that such information does not contain the amounts of taxes paid nor any other information deemed by the Tax Commissioner to be confidential

Under penalty of law for false swearing (West Virginia Code, §61-5-3), Bidder hereby certifies that this certificate is true and accurate in all respects; and that if a contract is issued to Bidder and if anything contained within this certificate changes during the term of the contract, Bidder will notify the Purchasing Division in writing immediately.

Bidder: _____ Signed: [Signature]
Date: _____ Title: _____

*Check any combination of preference consideration(s) indicated above. which you are entitled to receive

STATE OF WEST VIRGINIA
Purchasing Division

PURCHASING AFFIDAVIT

VENDOR OWING A DEBT TO THE STATE:

West Virginia Code §5A-3-10a provides that: No contract or renewal of any contract may be awarded by the state or any of its political subdivisions to any vendor or prospective vendor when the vendor or prospective vendor or a related party to the vendor or prospective vendor is a debtor and the debt owed is an amount greater than one thousand dollars in the aggregate

PUBLIC IMPROVEMENT CONTRACTS & DRUG-FREE WORKPLACE ACT:

If this is a solicitation for a public improvement construction contract, the vendor, by its signature below, affirms that it has a written plan for a drug-free workplace policy in compliance with Article 1D, Chapter 21 of the **West Virginia Code**. The vendor **must** make said affirmation with its bid submission. Further, public improvement construction contract may not be awarded to a vendor who does not have a written plan for a drug-free workplace policy in compliance with Article 1D, Chapter 21 of the **West Virginia Code** and who has not submitted that plan to the appropriate contracting authority in timely fashion. For a vendor who is a subcontractor, compliance with Section 5, Article 1D, Chapter 21 of the **West Virginia Code** may take place before their work on the public improvement is begun

ANTITRUST:

In submitting a bid to any agency for the state of West Virginia, the bidder offers and agrees that if the bid is accepted the bidder will convey, sell, assign or transfer to the state of West Virginia all rights, title and interest in and to all causes of action it may now or hereafter acquire under the antitrust laws of the United States and the state of West Virginia for price fixing and/or unreasonable restraints of trade relating to the particular commodities or services purchased or acquired by the state of West Virginia. Such assignment shall be made and become effective at the time the purchasing agency tenders the initial payment to the bidder.

I certify that this bid is made without prior understanding, agreement, or connection with any corporation, firm, limited liability company, partnership or person or entity submitting a bid for the same materials, supplies, equipment or services and is in all respects fair and without collusion or fraud. I further certify that I am authorized to sign the certification on behalf of the bidder or this bid

LICENSING:

Vendors must be licensed and in good standing in accordance with any and all state and local laws and requirements by any state or local agency of West Virginia, including, but not limited to, the West Virginia Secretary of State's Office, the West Virginia Tax Department, West Virginia Insurance Commission, or any other state agencies or political subdivision. Furthermore, the vendor must provide all necessary releases to obtain information to enable the Director or spending unit to verify that the vendor is licensed and in good standing with the above entities

CONFIDENTIALITY:

The vendor agrees that he or she will not disclose to anyone, directly or indirectly, any such personally identifiable information or other confidential information gained from the agency, unless the individual who is the subject of the information consents to the disclosure in writing or the disclosure is made pursuant to the agency's policies, procedures and rules. Vendor further agrees to comply with the Confidentiality Policies and Information Security Accountability Requirements, set forth in <http://www.state.wv.us/admin/purchase/privacy/noticeConfidentiality.pdf>

Under penalty of law for false swearing (**West Virginia Code §61-5-3**), it is hereby certified that the vendor affirms and acknowledges the information in this affidavit and is in compliance with the requirements as stated

Vendor's Name: VIRGINIA PLAYGROUND SERVICES
Authorized Signature: M. James Benedict, Agent Date: 8-10-09

SEE LETTER INCLUDED

All playground equipment and engineered wood fiber must meet the following requirements:

- ✓ yes • Compliance with U.S. Consumer Product Safety Commission, Handbook for Public Playground Safety.
- ✓ yes • Compliance with ASTM Standard F 1487
- ✓ yes • Compliance with Architectural and Transportation Barriers Compliance Board, Americans with Disabilities Act (ADA) Accessibility Guidelines for Buildings and Facilities; Play Areas.

SEE ATTACHED

Vendors must submit the following attachments:

- ✓ yes • Complete manufacturer's parts specifications and warranties.
- ✓ yes • Layout drawing to scale of the proposed play structure or equipment
- ✓ yes • ASTM and CPSC Statement of Compliance

Additionally, all playground equipment should have UV protection on all rotational molded plastics and all vinyl coatings on posts, handrails, and roofs should have anti-microbial agents.

Warranties:

SEE WARRANTY PAGE ATTACHED

- All equipment and engineered wood fiber must be guaranteed to be free of defects in workmanship and material for a minimum of one year from date of acceptance. However, if manufacturer warranty periods are longer than the required minimum one year warranty, those warranties shall apply.

The award may be split if it is in the best interest of the West Virginia Division of Natural Resources.

SMALL

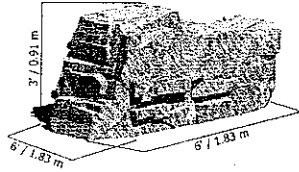

Product Name	MAJESTIC MOUNTAIN ROCK
Product Number	DX-RO3122B
Size -- Length	1.83 m / 6' 0"
Size -- Width	1.83 m / 6' 0"
Size -- Height	0.91 m / 3' 0"
Shipping Weight	860 kg / 1896 0 lb
Shipping Volume	4.1 m ³ / 144.8 ft ³
Features	1

	ASTM F-1487	CSA Z614	EN 1176
Ages	5 years - 12 years	5 years - 12 years	6 years - 12 years
Capacity	6	6	6
Use Zone -- Length	6.71 m / 22' 0"	6.71 m / 22' 0"	6.71 m / 22' 0"
Use Zone -- Width	6.71 m / 22' 0"	6.71 m / 22' 0"	6.71 m / 22' 0"
Fall Height	0.91 m / 3' 0"	0.91 m / 3' 0"	0.91 m / 3' 0"

Product Features:

ROCK CONSTRUCTION: Manufactured from colour-integrated Glass Fiber Reinforced Concrete (GFRC) over structural steel frame. Glass Fiber is Alkali-Resistant type glass formulated for concrete. GFRC shall be 1500 PSI (10.3 MPa) in tension, 5000 PSI (34.5 MPa) in compression.

ROCK COLOURING: Hardened GFRC is coloured with Alkali reactive chemical stain, which permanently changes the surface colour of the concrete. Final colouring is achieved with latex stain made for concrete.

ROCK REPAIR: GFRC is readily repairable no matter the age of the material.

COMPLIANT WITH:
CAN/CSA-Z614-07
ASTM F-1487-07a^{e1}
EN-1176
CPSC Handbook for Public Playground Safety

INSTALLATION: This should be installed only by a NPSI, CPSI or equivalent certified installer.

ROCKS! WARRANTY: Dynamo Industries (Manufacturer) warrants all Dynamo ROCKS! products (Products) to be free from defect in materials or workmanship for a period of (1) one year during normal use and installation and in accordance with our published specifications. If the purchaser discovers within this period a failure of the product to conform to specifications, or a defect in material or workmanship, the purchaser must promptly notify Manufacturer in writing within fifteen (15) days of discovering the defect. Within a reasonable time after notification, at the sole option of Manufacturer, Manufacturer shall perform a repair or correct these products if defective in manufacturing workmanship, materials or parts only, labour is excluded.



* LARGE

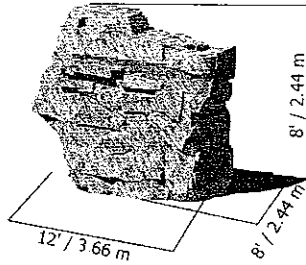

Product Name	KING PEAK ROCK
Product Number	DX-RO1275B
Size -- Length	3.66 m / 12' 0"
Size -- Width	2.44 m / 8' 0"
Size -- Height	2.44 m / 8' 0"
Shipping Weight	2180 kg / 4806 l lb
Shipping Volume	24.6 m ³ / 868.7 ft ³
Foundations	1

	ASTM F-1487	CSA Z614	EN 1176
Ages	5 years - 12 years	5 years - 12 years	6 years - 12 years
Capacity	12	12	12
Use Zone -- Length	8.54 m / 28' 0"	8.54 m / 28' 0"	8.54 m / 28' 0"
Use Zone -- Width	7.32 m / 24' 0"	7.32 m / 24' 0"	7.32 m / 24' 0"
Fall Height	2.44 m / 8' 0"	2.44 m / 8' 0"	2.44 m / 8' 0"

Product Features:

ROCK CONSTRUCTION: Manufactured from colour-integrated Glass Fiber Reinforced Concrete (GFRC) over structural steel frame. Glass Fiber is Alkali-Resistant type glass formulated for concrete. GFRC shall be 1500 PSI (10.3 MPa) in tension, 5000 PSI (34.5 MPa) in compression.

ROCK COLOURING: Hardened GFRC is coloured with Alkali reactive chemical stain, which permanently changes the surface colour of the concrete. Final colouring is achieved with latex stain made for concrete.

ROCK REPAIR: GFRC is readily repairable no matter the age of the material.

COMPLIANT WITH:
CAN/CSA-Z614-07
ASTM F-1487-07a^{e1}
EN-1176
CPSC Handbook for Public Playground Safety

INSTALLATION: This should be installed only by a NPSI, CPSI or equivalent certified installer.

ROCKS! WARRANTY: Dynamo Industries (Manufacturer) warrants all Dynamo ROCKS! products (Products) to be free from defect in materials or workmanship for a period of (1) one year during normal use and installation and in accordance with our published specifications. If the purchaser discovers within this period a failure of the product to conform to specifications or a defect in material or workmanship, the purchaser must promptly notify Manufacturer in writing within fifteen (15) days of discovering the defect. Within a reasonable time after notification, at the sole option of Manufacturer, Manufacturer shall perform a repair or correct these products if defective in manufacturing workmanship, materials or parts only, labour is excluded.



DYNAMO ROCKS!

Alpine Series Information

SPECIFICATIONS AND DESCRIPTION

Manufactured from color integrated Glass Fiber Reinforced Concrete (GFRC) over structural steel frame. Glass fiber is Alkali Resistant (AR) type glass formulated for concrete. GFRC shall be 1,500 pounds per square inch in tension, 5,000 pounds per square inch in compression. Hardened GFRC is colored with an Alkali reactive chemical stain, which permanently changes the surface color of the concrete. Final coloring is achieved with latex stain made for concrete. GFRC is readily repairable no matter the age of the material.

The estimated delivery date will be confirmed within 24 hours prior to shipping. If delivery date is changed a service charge of 10% of the shipping charge will be added to the rescheduled shipping.

It is the responsibility of the installation contractor to coordinate with the driver to insure timely offloading. The truck will remain on-site for 2 hours after the appointed delivery time. After this period there would be a fee of \$50 per hour.

INSTALLATION

Read installation instructions thoroughly before starting installation process.

1. Foundation shall be prepared in advance of delivery of the climber. Base shall be compacted stone base - 12" minimum thickness with a vibratory compactor - to be determined by local soil conditions. Density requirement is 95% compaction with final condition of stone as level and stable so as not to shift when traveled on or during surface installation process. Area shall be 8'6" x 8'6".
2. King Peak is shipped in one piece on a Flatbed Semi to site. Fork Lift pockets are built in for lifting. Placement of components shall be placed with a Lull-type Forklift, Crane or Boom Truck capable of lifting 6,000 pounds centered on the compacted stone foundation. Test overall stability and rigidity of equipment. Take care in protecting the King Peak by not to make contact with concrete surface with installation equipment.
3. Shock absorbing properties of safety surfacing materials vary. If you determine that less or more than 12" of surfacing is required, make up the difference in elevation with earth and base before applying the surfacing. A soft, resilient surface should be placed around all climbers, extending at least eight feet in all directions surrounding the climber. NEVER INSTALL PLAY EQUIPMENT ON CONCRETE OR ASPHALT. A fall on a hard surface can result in serious injury to the equipment user.

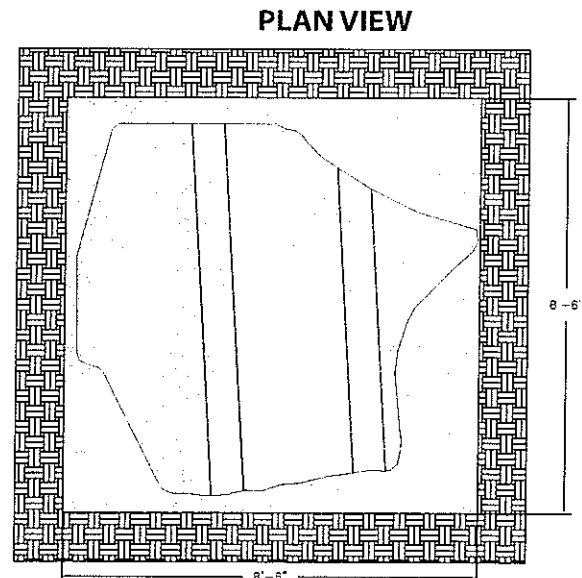
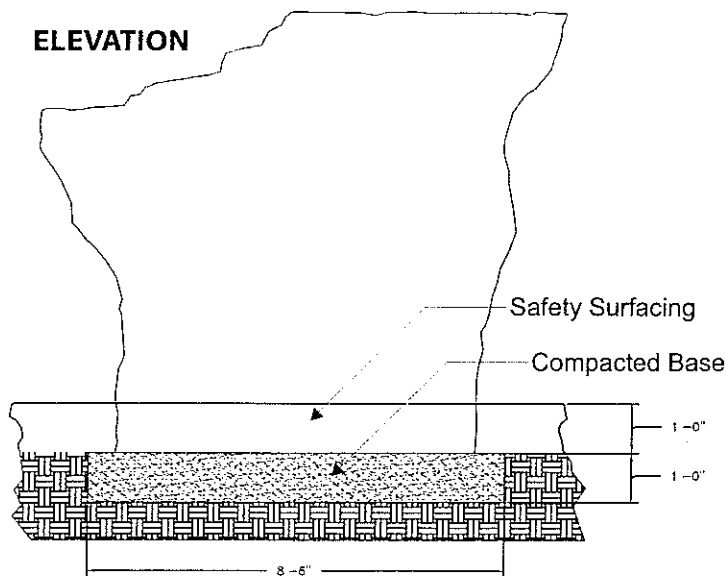

This warranty does not apply to:

- 1 Damage resulting from improper use.
- 2 Any product, component or part not supplied by Manufacturer
- 3 Defects generated by uses other than those for which it was created
- 4 Damage resulting from vandalism
- 5 Damage resulting from natural catastrophic events
- 6 Normal expected wear or weathering such as colour changes, minor scratches or normal weather-related stains
- 7 Accidents, injuries or liabilities which result from the use of Products or services
- 8 Damage caused during shipment
- 9 Damage which results from incorrect installation that does not conform to published instructions and specifications

This warranty period of 12 months begins on the date that Products are shipped. The warranty starting and ending dates do not coincide with payment dates or the completion of work done by others. Warranty is void if sand or pea gravel safety surfacing is used as a resilient surface under products. NOTE: All concrete has naturally occurring hairline cracks and these are not product defects.

These warranties cover either replacement or repair, at the Manufacturer's discretion, of any Products according to the above descriptions. Transportation and installation-on-site costs are not covered by these warranties, except where specific arrangements are made with written consent from the Manufacturer.

To make claim under the terms of the Warranty, the Buyer's written statement of claim, along with a copy of the original invoice, maintenance records, and supporting photographs, must be sent to the below listed address.

OPTIONS:

Optional Equipment Includes:

- ROCKSLIDE™ FOR KING PEAK (Max Qty: 1) #DX-RO1275S
- ASCENT CLIMBER™ (Max Qty: 1) #DX-RO9250N



DYNAMO ROCKS!

Alpine Series Information



Start with a base of compacted aggregate

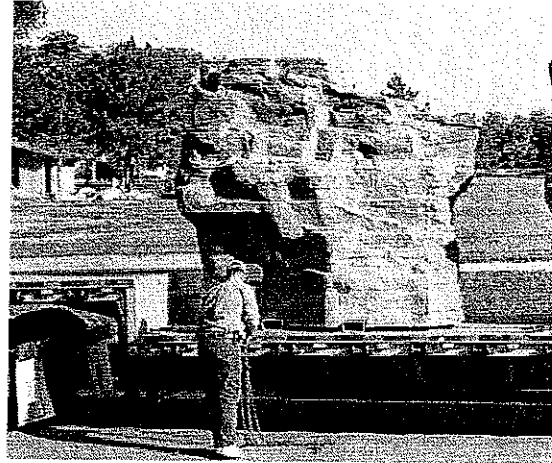

King Peak is shipped in one piece on a Flatbed Semi

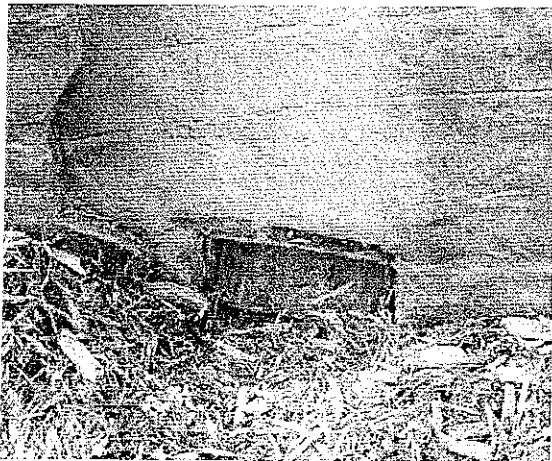

Forklift pockets built in for Lifting



Lower the King Peak into place with a Lull-type Forklift, Crane or Boom

WARNING

INSTALLATION OVER
A HARD SURFACE
SUCH AS CONCRETE,
ASPHALT, OR PACKED
EARTH MAY RESULT
IN SERIOUS INJURY
OR DEATH
FROM FALLS.

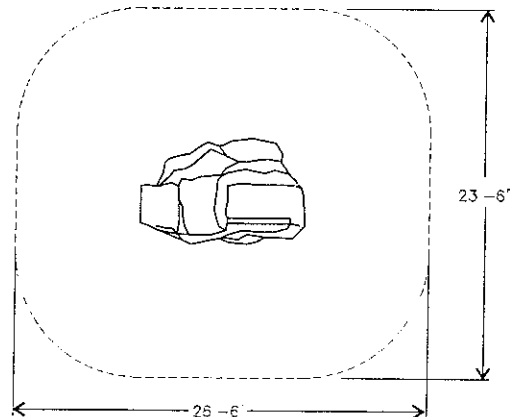

INDEPENDENT SWING SPECIFICATIONS

 **Kid Builders™ Swings** beam shall be fabricated from 60 mm (2 3/8") O.D. 5 gauge pre-galvanized steel tube. Uprights shall be fabricated from 127 mm (5") O.D. 11 gauge pre-galvanized steel. Both shall have a baked-on electrostatically applied polyester dry powder coating. The components are freed of excess weld spatter and shall be cleaned in a multiple bath system, which shall include a rust-inhibitive iron phosphate wash prior to painting.

 **Kid Builders™ 8' (2.4 m) Arch Swings** beam shall be fabricated from 60 mm 5 gauge pre-galvanized steel tube bent into an arch. Uprights shall be ~~4~~5 inch O.D. The beam and uprights shall have a baked-on electrostatically applied polyester dry powder coating. Anti Wrap-over swing bearings (U.S. Patent 6,123,480) shall be fabricated from sand cast bronze with injection molded nylon plastic. Swing chains shall be 4/0 straight link galvanized steel. OR Stainless steel when specified. The components are freed of excess weld spatter and shall be cleaned in a multiple bath system, which shall include a rust-inhibitive iron phosphate wash prior to painting. All other connecting hardware shall be stainless steel.

Standard Belt Swing Seats shall be rubber with a tempered steel insert molded inside, rendering them slashproof. Swing chains shall be 4/0 straight link galvanized steel OR stainless steel when specified.

Tot Swing Seats shall be heavy duty construction, fabricated from black rubber with a tempered steel insert molded inside, rendering them slashproof. Tot seat shall be fully enclosed to prevent slipping out and provide lower back support. Two sizes of leg cutouts make this seat versatile enough to accommodate larger children with special needs also. Swing chains shall be 4/0 straight link galvanized steel. OR stainless steel when specified,

Hardware: Bolts, Nuts, Screws, Threaded Spacers, Washers and Other Hardware used in the assembly of components shall be Stainless Steel and be tamper resistant. All necessary hardware shall be provided

galvanized steel. Standard Belt Swing Seats shall be heavy duty construction, fabricated from 70 durometer EPDM rubber with a tempered steel insert molded inside, rendering them slash proof.

HEAVY DUTY SWING (All Seats) beam shall be fabricated from 60 mm (2.375") O.D. 5 gauge pre-galvanized steel tube. Swing legs shall be fabricated from 60 mm (2.375") O.D. 10 gauge pre-galvanized steel pipe. Swing yokes shall be fabricated from 73 mm (2.875") O.D. 6 gauge pre-galvanized steel. The beam and uprights shall painted per PPLT PAINT Specification. Anti Wrap-over swing bearings (U.S. Patent 6,123,480) shall be fabricated from 415D sand cast Aluminum Bronze with injection molded nylatron plastic sleeve. Swing chains shall be 4/0 straight link galvanized steel. All seats shall have ultraviolet (UV) light stabilizers, anti-static guard and black color molded in. Swings seats shall be flame retardant and also provide excellent chemical resistance.

Standard Belt Swing Seats shall be heavy duty construction, fabricated from 70 durometer EPDM rubber with a tempered steel insert molded inside, rendering them slash proof.

Tot Swing Seats shall be heavy duty construction, fabricated from black EPDM rubber with a tempered steel insert molded inside, rendering them slash proof. Tot seat shall be fully enclosed to prevent slipping out and provide lower back support. Two sizes of leg cutouts make this seat versatile enough to accommodate larger children with special needs also.

~~Duraglide Standard Swing Seat shall be molded using water-blown integral skin Polyurethane foam. This material yields excellent physical properties while providing a soft comfortable feel. The internal reinforcing plate shall be 2.3 mm (.09") thick steel. Attachment loops shall be formed from 8 mm (.311") diameter 304 stainless steel rod with a tensile strength of 586mpa (85,000psi).~~

~~The Inclusive Swing Seat shall be rotationally molded per PPLT ROTO Specification with molded in graphics. The assembly contains 9.5mm (3/8") steel zinc-dichromate plate and 33 mm (1.315") O.D. pre-galvanized steel tubing painted per PPLT PAINT Specification. Chains for Inclusive Seat shall be coated per PPLT PVC Specification.~~

Destructible vinyl sticker

swings

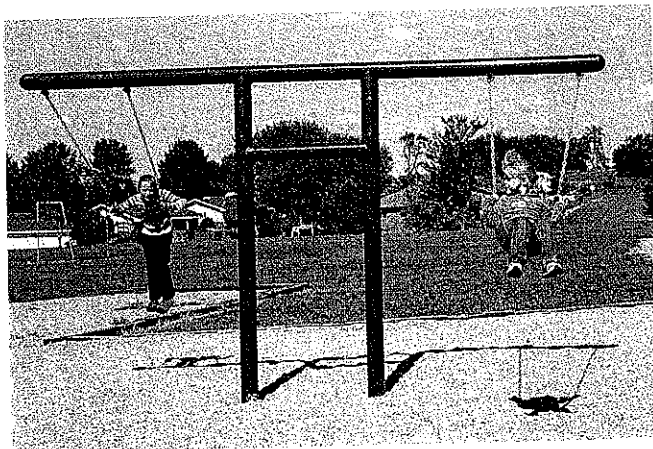

2012S TWINGS WITH 2 BELT SEATS \$1,257

- 5" O D Posts and Top Rail

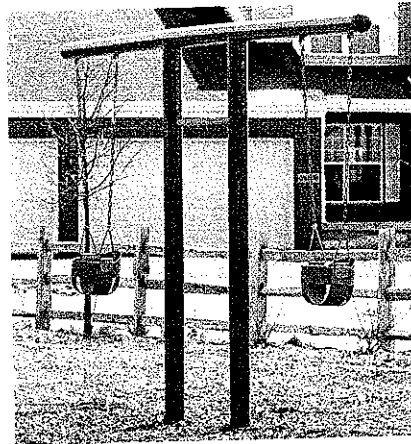

2012T TWINGS WITH 2 TOT SEATS \$1,349

- 5" O D Posts and Top Rail

Frame Only	With Belt Seats	With 360° Tot Seats**	# of Seats	Top Rail Height	Ground Space & Protective Area**
5" OD SINGLE POST SWINGS WITH PAINTED FRAME AND 2-3/8" OD TOP RAIL					
714-735-2* 165 lbs (75 kg) \$809	714-735-2S 185 lbs (84 kg) \$978	714-735-2T 200 lbs (91 kg) \$1,069	2	8'	GS: 1' x 12' (3m x 3.7m) PA: 32' x 24' (7.3m x 7.3m)
714-735-4 270 lbs (120 kg) \$1,378	714-735-4S 310 lbs (141 kg) \$1,714	714-735-4T 330 lbs (150 kg) \$1,897	4	8'	GS: 1' x 23' (3m x 7m) PA: 32' x 35' (9.8m x 10.7m)
714-735-6 375 lbs (170 kg) \$1,955	714-735-6S 440 lbs (200 kg) \$2,458	714-735-6T 470 lbs (213 kg) \$2,735	6	8'	GS: 1' x 34' (3m x 10.4m) PA: 32' x 46' (9.8m x 14m)
714-735-8 480 lbs (218 kg) \$2,527	714-735-8S 560 lbs (254 kg) \$3,199	714-735-8T 600 lbs (272 kg) \$3,567	8	8'	GS: 1' x 45' (3m x 13.7m) PA: 32' x 57' (9.8m x 17.4m)
5" OD TWINGS (T-SWINGS) WITH PAINTED FRAME					
2012 255 lbs. (116 kg) \$1,089	2012S 275 lbs. (125 kg) \$1,257	2012T 285 lbs (129 kg) \$1,349	2	8'	GS: 1' x 13.6' (3m x 4.1m) PA: 32' x 25.6' (9.8m x 7.7m)

*Special Frames Available for Therapeutic Seat(s)

**The protective area for the to/fro direction for Tot Seat Swings is 28'