



State of West Virginia
 Department of Administration
 Purchasing Division
 2019 Washington Street East
 Post Office Box 50130
 Charleston, WV 25305-0130

Request for Quotation

RFQ NUMBER
 DNR210017

PAGE
 1

ADDRESS CORRESPONDENCE TO ATTENTION OF
 KRISTA FERRELL
 304-558-2596

PROPERTY

RFQ COPY
 TYPE NAME/ADDRESS HERE

PLAYGROUND SPECIALISTS, INC.
 17352 N. SETON AVE.
 EMMITSBURG, MD 21727

SHIP TO

DIVISION OF NATURAL RESOURCES
 PINNACLE ROCK STATE PARK
 ATTN: PARK SUPERINTENDENT
 POST OFFICE BOX 704
 BLUEFIELD, WV
 24701 589-5307

DATE PRINTED	TERMS OF SALE	SHIP VIA	F.O.B.	FREIGHT TERMS
07/23/2009				

BID OPENING DATE: 08/11/2009 BID OPENING TIME 01:30PM

LINE	QUANTITY	UOP	CAT NO.	ITEM NUMBER	UNIT PRICE	AMOUNT
0001	1	LS		650-38		
<p>PLAYGROUND EQUIPMENT (NOT OTHERWISE CLASSIFIED)</p> <p>REQUEST FOR QUOTATION (RFQ)</p> <p>THE WEST VIRGINIA STATE PURCHASING DIVISION FOR THE AGENCY, THE WEST VIRGINIA DIVISION OF NATURAL RESOURCES, IS SOLICITING BIDS TO PROVIDE PLAYGROUND EQUIPMENT FOR PINNACLE ROCK STATE PARK LOCATED IN BRAMWELL, WEST VIRGINIA PER THE ATTACHED SPECIFICATIONS.</p> <p>NO INSTALLATION IS REQUIRED.</p> <p>TECHNICAL QUESTIONS CONCERNING THIS PROJECT MUST BE SUBMITTED TO FRANK WHITTAKER IN THE WEST VIRGINIA STATE PURCHASING DIVISION VIA FAX AT 304-558-4115 OR VIA EMAIL AT FRANK.M.WHITTAKER@WV.GOV. DEADLINE FOR ALL TECHNICAL QUESTIONS IS JULY 30, 2009 AT THE CLOSE OF BUSINESS. ALL TECHNICAL QUESTIONS RECEIVED, IF ANY, WILL BE ANSWERED BY ADDENDUM AFTER THE DEADLINE HAS LAPSED.</p> <p>QUESTIONS CONCERNING THE PROCESS BY WHICH A VENDOR MAY SUBMIT A BID TO THE STATE OF WEST VIRGINIA ARE NOT CONSIDERED TO BE TECHNICAL QUESTIONS AND MAY BE SUBMITTED AT ANY TIME PRIOR TO THE BID OPENING AND IN ANY FORMAT.</p> <p>THE MODEL/BRAND/SPECIFICATIONS NAMED HEREIN ESTABLISH</p>						

RECEIVED
 2009 AUG -5 AM 11:54
 WV PURCHASING DIVISION

SEE REVERSE SIDE FOR TERMS AND CONDITIONS

SIGNATURE <i>SE Self</i>	TELEPHONE 800/385-0075	DATE 8/5/09
TITLE SALES MANAGER	FEIN 52-2132 887	ADDRESS CHANGES TO BE NOTED ABOVE

WHEN RESPONDING TO RFQ, INSERT NAME AND ADDRESS IN SPACE ABOVE LABELED 'VENDOR'

**GENERAL TERMS & CONDITIONS
REQUEST FOR QUOTATION (RFQ) AND REQUEST FOR PROPOSAL (RFP)**

1. Awards will be made in the best interest of the State of West Virginia.
2. The State may accept or reject in part, or in whole, any bid.
3. All quotations are governed by the *West Virginia Code* and the *Legislative Rules* of the Purchasing Division
4. Prior to any award, the apparent successful vendor must be properly registered with the Purchasing Division and have paid the required \$125 fee.
5. All services performed or goods delivered under State Purchase Order/Contracts are to be continued for the term of the Purchase Order/Contracts, contingent upon funds being appropriated by the Legislature or otherwise being made available. In the event funds are not appropriated or otherwise available for these services or goods, this Purchase Order/Contract becomes void and of no effect after June 30.
6. Payment may only be made after the delivery and acceptance of goods or services.
7. Interest may be paid for late payment in accordance with the *West Virginia Code*.
8. Vendor preference will be granted upon written request in accordance with the *West Virginia Code*
9. The State of West Virginia is exempt from federal and state taxes and will not pay or reimburse such taxes
10. The Director of Purchasing may cancel any Purchase Order/Contract upon 30 days written notice to the seller.
11. The laws of the State of West Virginia and the *Legislative Rules* of the Purchasing Division shall govern all rights and duties under the Contract, including without limitation the validity of this Purchase Order/Contract.
12. Any reference to automatic renewal is hereby deleted. The Contract may be renewed only upon mutual written agreement of the parties.
13. **BANKRUPTCY:** In the event the vendor/contractor files for bankruptcy protection, the State may deem this contract null and void, and terminate such contract without further order.
14. **HIPAA BUSINESS ASSOCIATE ADDENDUM:** The West Virginia State Government HIPAA Business Associate Addendum (BAA), approved by the Attorney General, and available online at the Purchasing Division's web site (<http://www.state.wv.us/admin/purchase/vrc/hipaa.htm>) is hereby made part of the agreement. Provided that, the Agency meets the definition of a Cover Entity (45 CFR §160.103) and will be disclosing Protected Health Information (45 CFR §160.103) to the vendor.
15. **WEST VIRGINIA ALCOHOL & DRUG-FREE WORKPLACE ACT:** If this Contract constitutes a public improvement construction contract as set forth in Article 1D, Chapter 21 of the West Virginia Code ("The West Virginia Alcohol and Drug-Free Workplace Act"), then the following language shall hereby become part of this Contract: "The contractor and its subcontractors shall implement and maintain a written drug-free workplace policy in compliance with the West Virginia Alcohol and Drug-Free Workplace Act, as set forth in Article 1D, Chapter 21 of the West Virginia Code. The contractor and its subcontractors shall provide a sworn statement in writing, under the penalties of perjury, that they maintain a valid drug-free work place policy in compliance with the West Virginia and Drug-Free Workplace Act. It is understood and agreed that this Contract shall be cancelled by the awarding authority if the Contractor: 1) Fails to implement its drug-free workplace policy; 2) Fails to provide information regarding implementation of the contractor's drug-free workplace policy at the request of the public authority; or 3) Provides to the public authority false information regarding the contractor's drug-free workplace policy."

INSTRUCTIONS TO BIDDERS

1. Use the quotation forms provided by the Purchasing Division.
2. **SPECIFICATIONS:** Items offered must be in compliance with the specifications. Any deviation from the specifications must be clearly indicated by the bidder. Alternates offered by the bidder as **EQUAL** to the specifications must be clearly defined. A bidder offering an alternate should attach complete specifications and literature to the bid. The Purchasing Division may waive minor deviations to specifications.
3. Complete all sections of the quotation form
4. Unit prices shall prevail in case of discrepancy.
5. All quotations are considered F.O.B. destination unless alternate shipping terms are clearly identified in the quotation.
6. **BID SUBMISSION:** All quotations must be delivered by the bidder to the office listed below prior to the date and time of the bid opening. Failure of the bidder to deliver the quotations on time will result in bid disqualifications: Department of Administration, Purchasing Division, 2019 Washington Street East, P.O. Box 50130, Charleston, WV 25305-0130



State of West Virginia
 Department of Administration
 Purchasing Division
 2019 Washington Street East
 Post Office Box 50130
 Charleston, WV 25305-0130

Request for Quotation

RFQ NUMBER
 DNR210017

PAGE
 2

ADDRESS CORRESPONDENCE TO ATTENTION OF
 KRISTA FERRELL
 804-558-2596

VENDOR

RFQ COPY
 TYPE NAME/ADDRESS HERE

SHIP TO

DIVISION OF NATURAL RESOURCES
 PINNACLE ROCK STATE PARK
 ATTN: PARK SUPERINTENDENT
 POST OFFICE BOX 704
 BLUEFIELD, WV
 24701 589-5307

DATE PRINTED 07/23/2009	TERMS OF SALE	SHIP VIA	F.O.B.	FREIGHT TERMS
----------------------------	---------------	----------	--------	---------------

BID OPENING DATE: 08/11/2009 BID OPENING TIME 01:30PM

LINE	QUANTITY	UOP	CAT NO	ITEM NUMBER	UNIT PRICE	AMOUNT
<p>THE ACCEPTABLE LEVEL OF QUALITY ONLY AND ARE NOT INTENDED TO REFLECT A PREFERENCE OR FAVOR ANY PARTICULAR BRAND OR VENDOR. VENDORS WHO ARE BIDDING ALTERNATES SHOULD SO STATE AND INCLUDE PERTINENT LITERATURE AND SPECIFICATIONS. FAILURE TO PROVIDE INFORMATION FOR ANY ALTERNATES MAY BE GROUNDS FOR REJECTION OF THE BID. THE STATE RESERVES THE RIGHT TO WAIVE MINOR IRREGULARITIES IN BIDS OR SPECIFICATIONS IN ACCORDANCE WITH SECTION 148-1-4 (F) OF THE WEST VIRGINIA LEGISLATIVE RULES AND REGULATIONS.</p> <p>CANCELLATION: THE DIRECTOR OF PURCHASING RESERVES THE RIGHT TO CANCEL THIS CONTRACT IMMEDIATELY UPON WRITTEN NOTICE TO THE VENDOR IF THE MATERIALS OR WORKMANSHIP SUPPLIED ARE OF AN INFERIOR QUALITY OR DO NOT CONFORM WITH THE SPECIFICATIONS OF THE BID AND CONTRACT HERE IN.</p> <p>EXHIBIT 10</p> <p>ADDENDUM ACKNOWLEDGEMENT</p> <p>I HEREBY ACKNOWLEDGE RECEIPT OF THE FOLLOWING CHECKED ADDENDUM(S) AND HAVE MADE THE NECESSARY REVISIONS TO MY PROPOSAL, PLANS AND/OR SPECIFICATION, ETC.</p> <p>ADDENDUM NOS. :</p> <p>NO. 1</p> <p>NO. 2</p> <p>NO. 3</p> <p>NO. 4</p> <p>NO. 5</p>						

SEE REVERSE SIDE FOR TERMS AND CONDITIONS

SIGNATURE <i>[Signature]</i>	TELEPHONE 800/385-0675	DATE 8/5/09
TITLE SALES MANAGER	FERN 52-2132 887	ADDRESS CHANGES TO BE NOTED ABOVE

WHEN RESPONDING TO RFQ, INSERT NAME AND ADDRESS IN SPACE ABOVE LABELED 'VENDOR'



State of West Virginia
 Department of Administration
 Purchasing Division
 2019 Washington Street East
 Post Office Box 50130
 Charleston, WV 25305-0130

Request for Quotation

RFQ NUMBER
 DNR210017

PAGE
 3

ADDRESS CORRESPONDENCE TO ATTENTION OF
 KRISTA FERRELL
 304-558-2596

RFQ COPY
 TYPE NAME/ADDRESS HERE

DIVISION OF NATURAL RESOURCES
 PINNACLE ROCK STATE PARK
 ATTN: PARK SUPERINTENDENT
 POST OFFICE BOX 704
 BLUEFIELD, WV
 24701 589-5307

DATE PRINTED	TERMS OF SALE	SHIP VIA	F.O.B.	FREIGHT TERMS
07/23/2009				

BID OPENING DATE: 08/11/2009 BID OPENING TIME 01:30PM

LINE	QUANTITY	UOP	CAT NO	ITEM NUMBER	UNIT PRICE	AMOUNT
<p>I UNDERSTAND THAT FAILURE TO CONFIRM THE RECEIPT OF THE ADDENDUM(S) MAY BE CAUSE FOR REJECTION OF THE BIDS.</p> <p>VENDOR MUST CLEARLY UNDERSTAND THAT ANY VERBAL REPRESENTATION MADE OR ASSUMED TO BE MADE DURING ANY ORAL DISCUSSION HELD BETWEEN VENDOR'S REPRESENTATIVES AND ANY STATE PERSONNEL IS NOT BINDING. ONLY THE INFORMATION ISSUED IN WRITING AND ADDED TO THE SPECIFICATIONS BY AN OFFICIAL ADDENDUM IS BINDING.</p> <p>..... SIGNATURE</p> <p>PLAYGROUND SPECIALISTS INC COMPANY</p> <p>..... DATE</p> <p>REV. 11/96</p> <p>BANKRUPTCY: IN THE EVENT THE VENDOR/CONTRACTOR FILES FOR BANKRUPTCY PROTECTION, THIS CONTRACT IS AUTOMATICALLY NULL AND VOID, AND IS TERMINATED WITHOUT FURTHER ORDER.</p> <p>REV. 1/2005</p> <p>NOTICE</p> <p>A SIGNED BID MUST BE SUBMITTED TO:</p> <p>DEPARTMENT OF ADMINISTRATION PURCHASING DIVISION BUILDING 15 2019 WASHINGTON STREET, EAST</p>						

SEE REVERSE SIDE FOR TERMS AND CONDITIONS

SIGNATURE	TELEPHONE	DATE
<i>ST Self</i>	803/385-0075	8/5/09
TITLE	FEIN	ADDRESS CHANGES TO BE NOTED ABOVE
SALES MANAGER	52-2132887	

WHEN RESPONDING TO RFQ, INSERT NAME AND ADDRESS IN SPACE ABOVE LABELED 'VENDOR'



State of West Virginia
 Department of Administration
 Purchasing Division
 2019 Washington Street East
 Post Office Box 50130
 Charleston, WV 25305-0130

Request for Quotation

RFQ NUMBER
 DNR210017

PAGE
 4

ADDRESS CORRESPONDENCE TO ATTENTION OF
 KRISTA FERRELL
 804-558-2596

RFQ COPY
 TYPE NAME/ADDRESS HERE

DIVISION OF NATURAL RESOURCES
 PINNACLE ROCK STATE PARK
 ATTN: PARK SUPERINTENDENT
 POST OFFICE BOX 704
 BLUEFIELD, WV
 24701 589-5307

DATE PRINTED 07/23/2009	TERMS OF SALE	SHIP VIA	F.O.B.	FREIGHT TERMS
----------------------------	---------------	----------	--------	---------------

BID OPENING DATE: 08/11/2009 BID OPENING TIME 01:30PM

LINE	QUANTITY	UQP	CAT NO	ITEM NUMBER	UNIT PRICE	AMOUNT
				CHARLESTON, WV 25305-0130		
<p>THE BID SHOULD CONTAIN THIS INFORMATION ON THE FACE OF THE ENVELOPE OR THE BID MAY NOT BE CONSIDERED:</p> <p>SEALED BID</p> <p>BUYER: KRISTA FERRELL-FILE 21</p> <p>REQ. NO.: DNR210017</p> <p>BID OPENING DATE: 08/11/2009</p> <p>BID OPENING TIME: 1:30 PM</p> <p>PLEASE PROVIDE A FAX NUMBER IN CASE IT IS NECESSARY TO CONTACT YOU REGARDING YOUR BID: ----- 301/271-9239</p> <p>PLEASE PRINT OR TYPE NAME OF PERSON TO CONTACT CONCERNING THIS QUOTE: ----- STEVEN SUFER</p> <p>***** THIS IS THE END OF RFQ DNR210017 ***** TOTAL: <u>18975⁰⁰</u></p>						

SEE REVERSE SIDE FOR TERMS AND CONDITIONS

SIGNATURE *St Sufer* TELEPHONE 800/385-0075 DATE 8/5/09
 TITLE SALES MANAGER FEIN 52-2132 887 ADDRESS CHANGES TO BE NOTED ABOVE

WHEN RESPONDING TO RFQ, INSERT NAME AND ADDRESS IN SPACE ABOVE LABELED 'VENDOR'

WVDNR210017
Pinnacle Rock State Park
PLAYGROUND EQUIPMENT SHEET

Please complete the below information concerning the brand(s) of equipment being bid in relation to this project. If bidding "or equal" brands, please attach manufacturer's literature documenting that it meets the mandatory requirements stated in the specifications. Vendors should note the areas of the provided manufacturer's literature that adheres to the mandatory requirements outlined in the Request For Proposal.

Item No.	Equipment	Manufacturer	Model
1	Cre8Play Strato Rock Climber, Model #STRATO1, or equal.	PLAYWORLD SYSTEMS	BD 0016 CASTLE BOULDER
2	Cre8Play Summit Rock Climber, Model #SUMMIT1, or equal.	PLAYWORLD SYSTEMS	BD 0013 PICNIC BOULDER
3	GameTime T-frame swing, Item #P831, or equal.	PLAYWORLD SYSTEMS	#0295 SINGLE POST SWING
4	GameTime T-frame zero-G chair, Item #8555, or equal.	PLAYWORLD SYSTEMS	#0224 ACCESSIBLE SEAT
5	GameTime super seat-2, Item #1479.	SEE	SRK-12A LARGE FLAT SEAT

Pinnacle Rock State Park Playground Equipment
PRICING SHEET

Item No.	Quantity	Description	Unit Price	Amount
1	1	Cre8Play Strato Rock Climber, Model #STRATO1, or equal.	12,975 ⁰⁰	12,975 ⁰⁰
2	1	Cre8Play Summit Rock Climber, Model #SUMMIT1, or equal.	4,750 ⁰⁰	4,750 ⁰⁰
3	1	GameTime T-frame swing, Item #P831, or equal.	785 ⁰⁰	785 ⁰⁰
4	1	GameTime T-frame zero-G chair, Item #8555, or equal.	385 ⁰⁰	385 ⁰⁰
5	1	GameTime super seat-2, Item #1479.	80 ⁰⁰	80 ⁰⁰
		TOTAL		18,975 ⁰⁰

Vendors must provide unit costs for all line items shown above. Failure to provide line item pricing will result in the disqualification of the vendor's bid.

State of West Virginia VENDOR PREFERENCE CERTIFICATE

Certification and application* is hereby made for Preference in accordance with **West Virginia Code**, §5A-3-37 (Does not apply to construction contracts) **West Virginia Code**, §5A-3-37, provides an opportunity for qualifying vendors to request (at the time of bid) preference for their residency status. Such preference is an evaluation method only and will be applied only to the cost bid in accordance with the **West Virginia Code**. This certificate for application is to be used to request such preference. The Purchasing Division will make the determination of the Resident Vendor Preference, if applicable.

- 1. **Application is made for 2.5% resident vendor preference for the reason checked:**
 Bidder is an individual resident vendor and has resided continuously in West Virginia for four (4) years immediately preceding the date of this certification; or,
 Bidder is a partnership, association or corporation resident vendor and has maintained its headquarters or principal place of business continuously in West Virginia for four (4) years immediately preceding the date of this certification; or 80% of the ownership interest of Bidder is held by another individual, partnership, association or corporation resident vendor who has maintained its headquarters or principal place of business continuously in West Virginia for four (4) years immediately preceding the date of this certification; or,
 Bidder is a nonresident vendor which has an affiliate or subsidiary which employs a minimum of one hundred state residents and which has maintained its headquarters or principal place of business within West Virginia continuously for the four (4) years immediately preceding the date of this certification; or,
- 2. **Application is made for 2.5% resident vendor preference for the reason checked:**
 Bidder is a resident vendor who certifies that, during the life of the contract, on average at least 75% of the employees working on the project being bid are residents of West Virginia who have resided in the state continuously for the two years immediately preceding submission of this bid; or,
- 3. **Application is made for 2.5% resident vendor preference for the reason checked:**
 Bidder is a nonresident vendor employing a minimum of one hundred state residents or is a nonresident vendor with an affiliate or subsidiary which maintains its headquarters or principal place of business within West Virginia employing a minimum of one hundred state residents who certifies that, during the life of the contract, on average at least 75% of the employees or Bidder's affiliate's or subsidiary's employees are residents of West Virginia who have resided in the state continuously for the two years immediately preceding submission of this bid; or,
- 4. **Application is made for 5% resident vendor preference for the reason checked:**
 Bidder meets either the requirement of both subdivisions (1) and (2) or subdivision (1) and (3) as stated above; or,
- 5. **Application is made for 3.5% resident vendor preference who is a veteran for the reason checked:**
 Bidder is an individual resident vendor who is a veteran of the United States armed forces, the reserves or the National Guard and has resided in West Virginia continuously for the four years immediately preceding the date on which the bid is submitted; or,
- 6. **Application is made for 3.5% resident vendor preference who is a veteran for the reason checked:**
 Bidder is a resident vendor who is a veteran of the United States armed forces, the reserves or the National Guard, if, for purposes of producing or distributing the commodities or completing the project which is the subject of the vendor's bid and continuously over the entire term of the project, on average at least seventy-five percent of the vendor's employees are residents of West Virginia who have resided in the state continuously for the two immediately preceding years.

Bidder understands if the Secretary of Revenue determines that a Bidder receiving preference has failed to continue to meet the requirements for such preference, the Secretary may order the Director of Purchasing to: (a) reject the bid; or (b) assess a penalty against such Bidder in an amount not to exceed 5% of the bid amount and that such penalty will be paid to the contracting agency or deducted from any unpaid balance on the contract or purchase order.

By submission of this certificate, Bidder agrees to disclose any reasonably requested information to the Purchasing Division and authorizes the Department of Revenue to disclose to the Director of Purchasing appropriate information verifying that Bidder has paid the required business taxes, provided that such information does not contain the amounts of taxes paid nor any other information deemed by the Tax Commissioner to be confidential.

Under penalty of law for false swearing (West Virginia Code, §61-5-3), Bidder hereby certifies that this certificate is true and accurate in all respects; and that if a contract is issued to Bidder and if anything contained within this certificate changes during the term of the contract, Bidder will notify the Purchasing Division in writing immediately.

Bidder: PLAYGROUND SPECIALISTS INC Signed: [Signature]
 Date: 8/5/09 Title: SALES MANAGER

*Check any combination of preference consideration(s) indicated above, which you are entitled to receive.

RFQ No DNR2/0017STATE OF WEST VIRGINIA
Purchasing Division**PURCHASING AFFIDAVIT****VENDOR OWING A DEBT TO THE STATE:**

West Virginia Code §5A-3-10a provides that: No contract or renewal of any contract may be awarded by the state or any of its political subdivisions to any vendor or prospective vendor when the vendor or prospective vendor or a related party to the vendor or prospective vendor is a debtor and the debt owed is an amount greater than one thousand dollars in the aggregate.

PUBLIC IMPROVEMENT CONTRACTS & DRUG-FREE WORKPLACE ACT:

If this is a solicitation for a public improvement construction contract, the vendor, by its signature below, affirms that it has a written plan for a drug-free workplace policy in compliance with Article 1D, Chapter 21 of the **West Virginia Code**. The vendor **must** make said affirmation with its bid submission. Further, public improvement construction contract may not be awarded to a vendor who does not have a written plan for a drug-free workplace policy in compliance with Article 1D, Chapter 21 of the **West Virginia Code** and who has not submitted that plan to the appropriate contracting authority in timely fashion. For a vendor who is a subcontractor, compliance with Section 5, Article 1D, Chapter 21 of the **West Virginia Code** may take place before their work on the public improvement is begun.

ANTITRUST:

In submitting a bid to any agency for the state of West Virginia, the bidder offers and agrees that if the bid is accepted the bidder will convey, sell, assign or transfer to the state of West Virginia all rights, title and interest in and to all causes of action it may now or hereafter acquire under the antitrust laws of the United States and the state of West Virginia for price fixing and/or unreasonable restraints of trade relating to the particular commodities or services purchased or acquired by the state of West Virginia. Such assignment shall be made and become effective at the time the purchasing agency tenders the initial payment to the bidder.

I certify that this bid is made without prior understanding, agreement, or connection with any corporation, firm, limited liability company, partnership or person or entity submitting a bid for the same materials, supplies, equipment or services and is in all respects fair and without collusion or fraud. I further certify that I am authorized to sign the certification on behalf of the bidder or this bid.

LICENSING:

Vendors must be licensed and in good standing in accordance with any and all state and local laws and requirements by any state or local agency of West Virginia, including, but not limited to, the West Virginia Secretary of State's Office, the West Virginia Tax Department, West Virginia Insurance Commission, or any other state agencies or political subdivision. Furthermore, the vendor must provide all necessary releases to obtain information to enable the Director or spending unit to verify that the vendor is licensed and in good standing with the above entities.

CONFIDENTIALITY:

The vendor agrees that he or she will not disclose to anyone, directly or indirectly, any such personally identifiable information or other confidential information gained from the agency, unless the individual who is the subject of the information consents to the disclosure in writing or the disclosure is made pursuant to the agency's policies, procedures and rules. Vendor further agrees to comply with the Confidentiality Policies and Information Security Accountability Requirements, set forth in <http://www.state.wv.us/admin/purchase/privacy/noticeConfidentiality.pdf>

Under penalty of law for false swearing (**West Virginia Code §61-5-3**), it is hereby certified that the vendor affirms and acknowledges the information in this affidavit and is in compliance with the requirements as stated

Vendor's Name: PLAYGROUND SPECIALISTS INC
 Authorized Signature: [Signature] Date: 8/5/09



Product Specifications

©Playworld Systems, Inc Tuesday, July 28, 2009

CASTLE BOULDER

Fiberglass - Sign

Sign is a solid one-piece panel with all copy and graphics embedded in the panel. Panel is manufactured out of fiberglass-reinforced plastic or equivalent with a non-yellowing, R-70 clear resin (or UV stabilized, acrylic-modified polyester resin) reinforced with high solubility, chopped strand fiberglass mat so that the index of refraction ensures total clarity of color, copy and graphics. Glass fibers will not be readily discernible on face. Material will have a glass content of no less than 28% of the total weight. Material will have an ambient temperature range of -65 to 350 degrees F. Material will have a min. barcol hardness of 50, tensile strength of 12,000 PSI, compressive strength of 20,000 PSI, and a flexural strength of 18,000 PSI. Minimum impact of the material is 6 ft. LBS. / in. Notch with a fire resistance of 500 degrees F. Material will not be permanently defaced by steam, acids, aromatics, scratching, inks, or paints and will be readily wiped clean with paint remover and solvents without affecting the appearance or legibility of the sign finish or graphics. Material will be opaque or translucent with a semi-gloss or matte finish. Panel edges will not be crazed or cracked, and the edge finish will be smooth, clean, and neat. Panel will be absolutely flat. Material will be warranted for a period of 10 years against chipping, delaminating, and fading.

Boulder

Boulder shall be manufactured with a min of 2000 psi polyfibercrete. It shall have 90lbs/cubic feet average density. The use surface is sandblasted to achieve desired texture. The texture and shape will mimic natural rock formations. Different features and variations in the surface will provide the climbing routes.

ZZBD0016

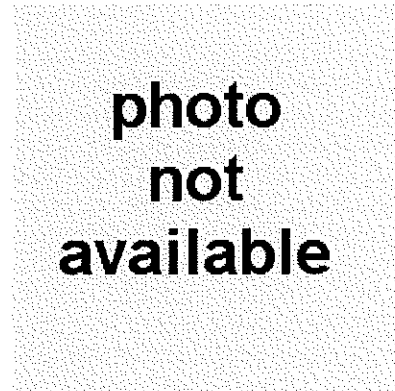

* See Note

Component Number:	ZZBD0016
Specification Rev:	PA1178
Component Weight:	13,920.00 Lbs.
Number of Users:	5
Amount of Concrete:	2.47 Yds.
Pre-Consumer Recycle:	0.00 Lbs.
Post-Consumer Recycle:	0.00 Lbs.
CO2e Footprint:	13,105.62 Kgs.

* The photos shown are for product representation only The actual products may vary in size and color depending upon application.



Product Specifications

©Playworld Systems, Inc Tuesday, July 28, 2009

PICNIC BOULDER

Fiberglass - Sign

Sign is a solid one-piece panel with all copy and graphics embedded in the panel. Panel is manufactured out of fiberglass-reinforced plastic or equivalent with a non-yellowing, R-70 clear resin (or UV stabilized, acrylic-modified polyester resin) reinforced with high solubility, chopped strand fiberglass mat so that the index of refraction ensures total clarity of color, copy and graphics. Glass fibers will not be readily discernible on face. Material will have a glass content of no less than 28% of the total weight. Material will have an ambient temperature range of -65 to 350 degrees F. Material will have a min. barcol hardness of 50, tensile strength of 12,000 PSI, compressive strength of 20,000 PSI, and a flexural strength of 18,000 PSI. Minimum impact of the material is 6 ft. LBS. / in. Notch with a fire resistance of 500 degrees F. Material will not be permanently defaced by steam, acids, aromatics, scratching, inks, or paints and will be readily wiped clean with paint remover and solvents without affecting the appearance or legibility of the sign finish or graphics. Material will be opaque or translucent with a semi-gloss or matte finish. Panel edges will not be crazed or cracked, and the edge finish will be smooth, clean, and neat. Panel will be absolutely flat. Material will be warranted for a period of 10 years against chipping, delaminating, and fading.

Boulder

Boulder shall be manufactured with a min of 2000 psi polyfibercrete. It shall have 90lbs/cubic feet average density. The use surface is sandblasted to achieve desired texture. The texture and shape will mimic natural rock formations. Different features and variations in the surface will provide the climbing routes.

ZZBD0013

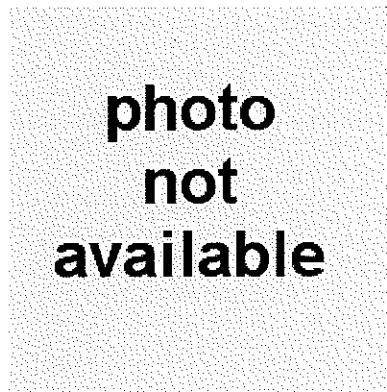

* See Note

Component Number:	ZZBD0013
Specification Rev:	PA1178
Component Weight:	4,690.00 Lbs.
Number of Users:	5
Pre-Consumer Recycle:	0.00 Lbs.
Post-Consumer Recycle:	0.00 Lbs.
CO2e Footprint:	3,627.63 Kgs.

* The photos shown are for product representation only. The actual products may vary in size and color depending upon application.

Use Zone

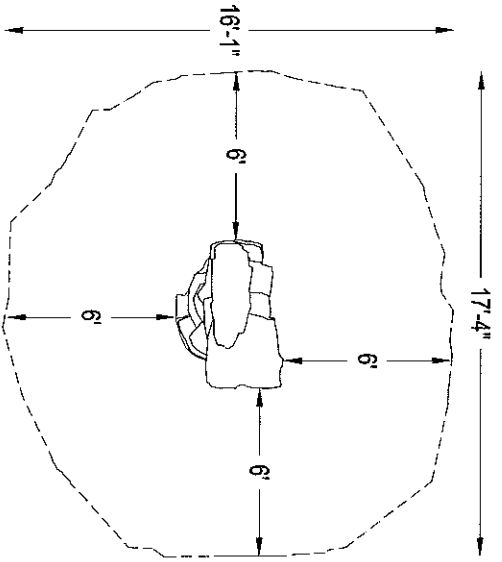

Tower Boulder
ZZBD0014

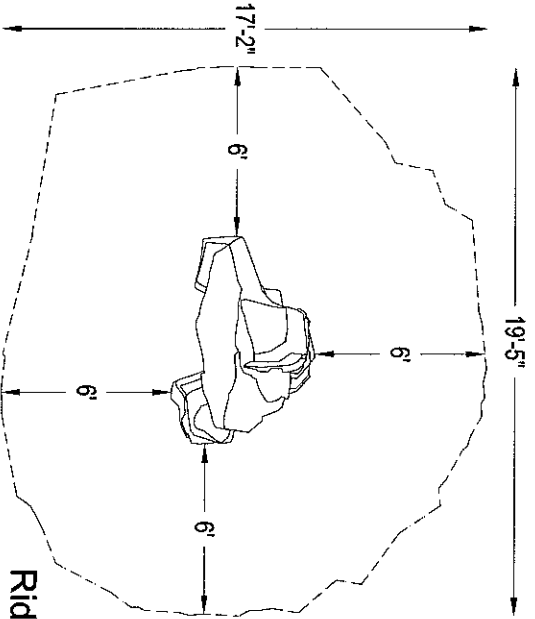

Ridge Boulder
ZZBD0015

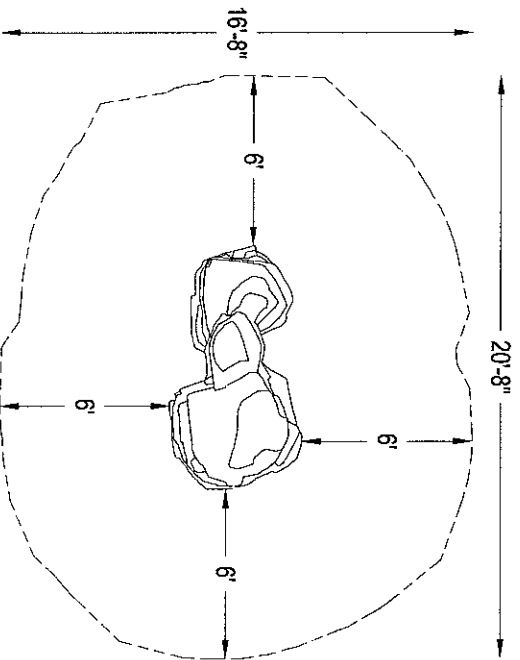

Castle Boulder
ZZBD0016

Use Zone

PLACEMENT OF CLIMBING BOULDERS:

Select the desired site location and position the climbing boulders. Measure for all use zones using the master layout drawing. Site should be level.

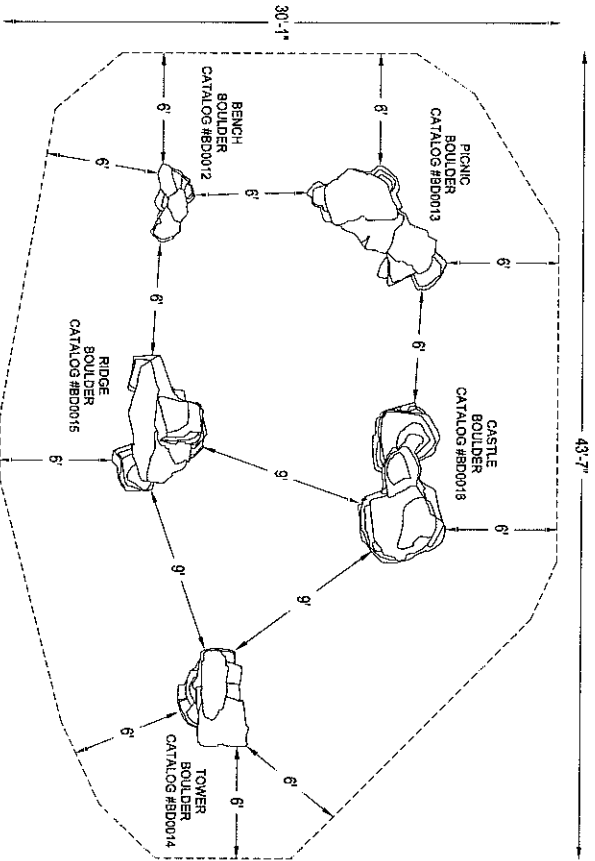

Note: The Diagram shown above is provided as an example only. The quantity, layout and placement of your climbing boulders may be different and you need to refer to your specific site plan for your particular configuration.

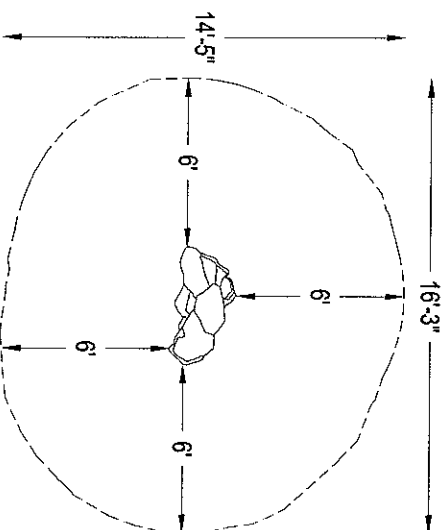

Bench Boulder
ZZBD0012

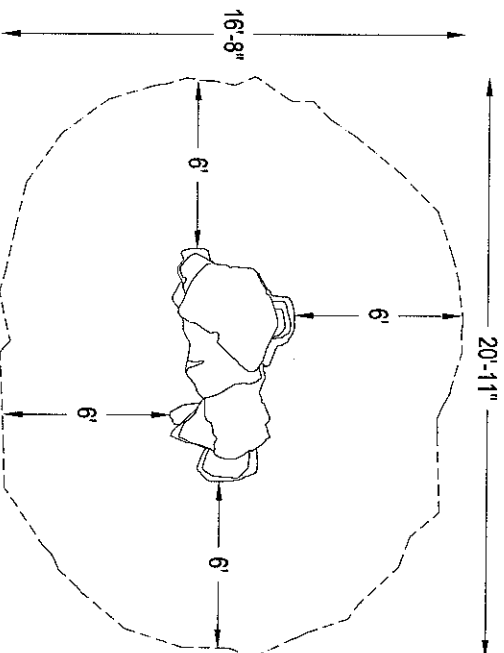

Picnic Boulder
ZZBD0013

Footing Dimensions

FOOTING OF CLIMBING BOULDERS:

A concrete pad is recommended for installation of the climbing boulders. Excavate hole according to the pad dimension below. Allow 72 hours for concrete to completely cure.

Important Note: Each concrete pad should have gravel fill 6 in below the local frost line

Concrete Pad Dimension Recommendation:

Boulder Model	Concrete Pad Dimension	Concrete Required
ZZBD0012	will sit directly on gravel fill	N/A
ZZBD0013	will sit directly on gravel fill	N/A
	Dim A	Dim B
ZZBD0014	8 ft. (2438 mm)	8 ft. (2438 mm)
ZZBD0015	9 ft. (2743 mm)	6 ft. (1829 mm)
ZZBD0016	10 ft. (2438 mm)	8 ft. (2438 mm)

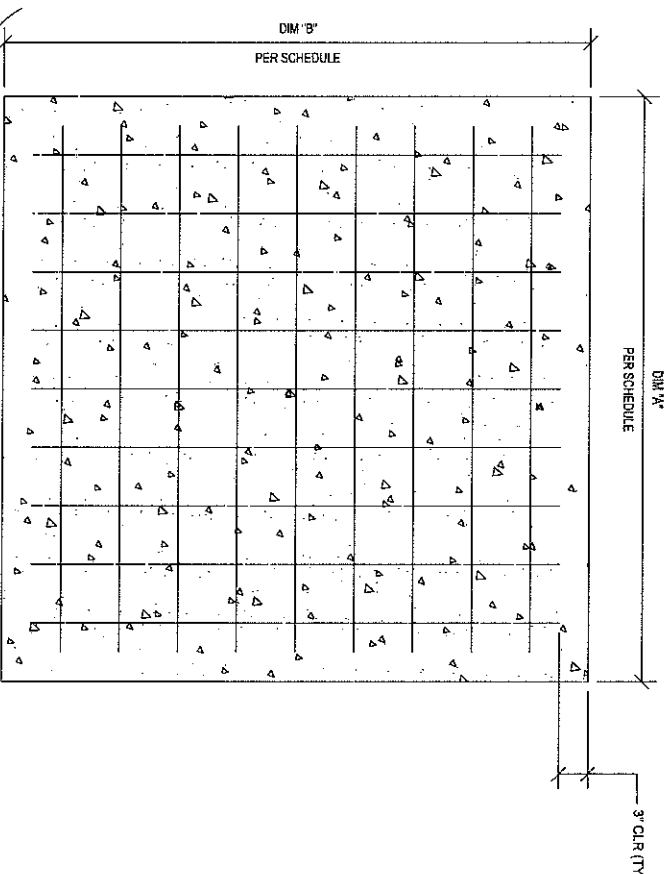

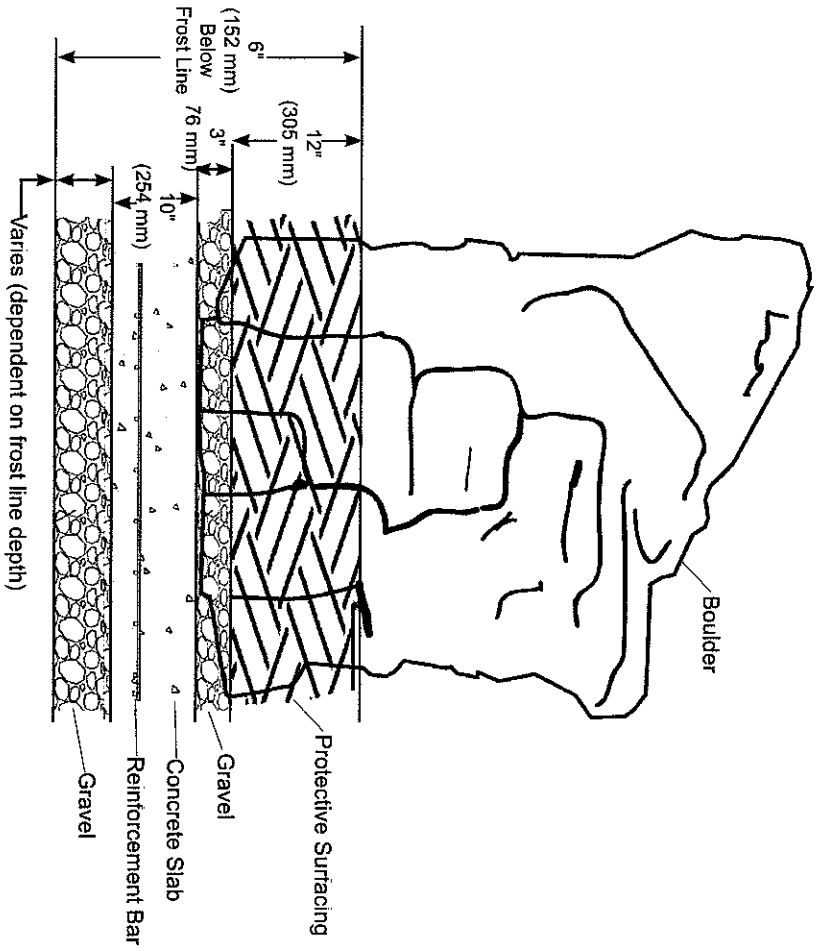

Footing Detail

FOOTING NOTES

- The area below the footing shall be excavated to a depth of 6" (152 mm) below the local frost line and filled with gravel or crushed rock compacted to 95%.
- If questioning local site conditions exist, site to be examined by a licensed engineer.
- Allowable soil bearing value of 1,500 PSF assumed (soil type V per I.B.C. table 1804.2).
- Concrete strength is 2,500 PSI minimum.
- Reinforcement is ASTM A615 Grade 60.
- Applicable Codes:
2006 I.B.C. / 2005 A.S.C.E.7
2005 A.C.I. 316
- Design Criteria:
Importance Factor = 1.00
Basic Wind Speed = 120 mph
Exposure Category = B
Seismic Response Coefficient: Cs = 0.40 (max)
Seismic soil class = D

Rigging Guidelines

RIGGING GUIDELINES

While these boulders are very strong and resistant to damage, improper rigging techniques can damage the product and more importantly can create a serious hazard to persons or property in the vicinity of the boulder movement. The following comments are guidelines that are not intended to replace sound practices for proper rigging. Rather they are provided as a supplement to proper rigging techniques.

Due to their size and weight, it is recommended that a crane be used for lifting and moving the boulders from the top with the supplied eyebolts. Refer to the crane operators expertise to apply safe rigging and lifting practices. Please refer to the weight charts below.

Boulder Model	Weight
ZZBD0012	1160 lbs. (527,3 kg)
ZZBD0013	4690 lbs. (2131,8 kg)
ZZBD0014	4640 lbs. (2109,1 kg)
ZZBD0015	7830 lbs. (3559,1 kg)
ZZBD0016	13920 lbs. (6327,3 kg)

Rope Model	Weight
ZZBD0018	9,9 lbs. (4,5 kg)
ZZBD0019	9,4 lbs. (4,3 kg)
ZZBD0020	76,7 lbs. (34,9 kg)
ZZBD0021	67,4 lbs. (30,6 kg)

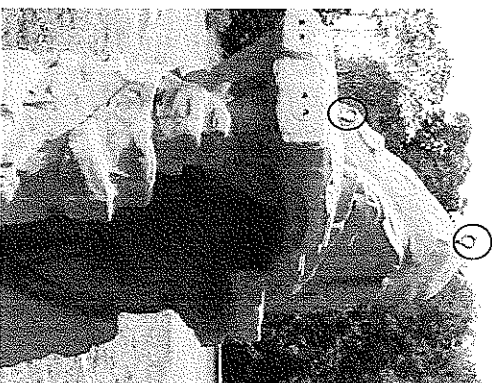

EYE BOLTS

Eye bolts are provided with each boulder, except the bench boulder, to aid in the rigging and lifting practices. When the boulders are in their desired location, the eye bolts should be removed. Refer to the patch and repair process on page 18 to remove the eye bolts and cover the holes after use.

Boulder Installation

Carefully read and understand these installation instructions before you begin.

Step 1: Before attempting to assemble your equipment, please review all installation information carefully. Should you experience any difficulty during the installation process, please call us at the phone number shown on the last page of these instructions.

Step 2: Separate and identify all components and hardware.

Step 3: Excavate footings as indicated on page 4 and page 5 of this document. Clearly mark the footings locations for easy installation.

Step 4: Attach the rigging equipment to the boulder using the eye bolts. Make sure they are securely attached before lifting.

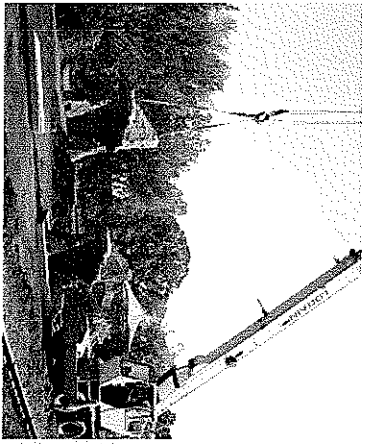
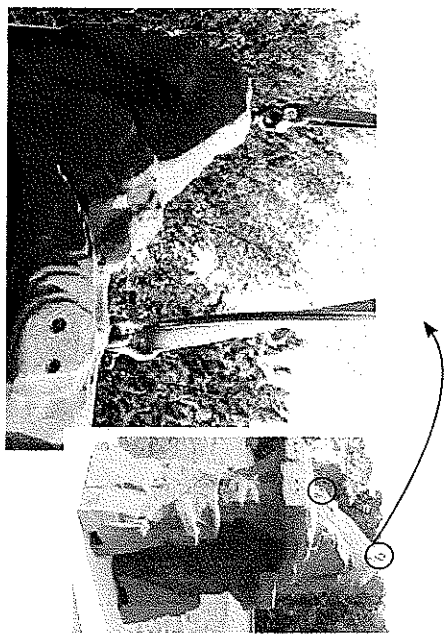

Step 5: Place boulder on the concrete slab according to your layout plan. Before detaching the crane connection, measure for accuracy.

Note: For ease in positioning, cut a 2" x 4" board to the length of space needed between boulders. While lowering the boulders into place, place the board between boulders to ensure proper distancing.



Product Specifications

©Playworld Systems, Inc. Wednesday, July 29, 2009

8ft SINGLE POST SWING ASSEMBLY

Swing Clevis - cast iron/ plated

Shall be manufactured of superior grade cast ductile iron and zinc plated for optimal surface protection. Shall have an integrated bronze bearing pressed in after powdercoating. Shall be finished with a baked on polyester powder coat. (See Superdurable Polyester Powder Coat Finish)

5 in. Support Post w/ Welded Ring & End Cap

Shall be an all-welded assembly fabricated of 5 in. outside diameter, 11 gauge galvanized steel tubing, .188 in. hot rolled pickled and oiled flat steel and a factory-installed cap. Shall be finished with a baked-on polyester powder coating or PrismCoat. (See PrismCoat / Polyester Powder Coat Finish)

Steel Tubing - 5 in. OD, 11 ga.

Tensile strength shall be 55,000 psi. Yield strength shall be 50,000 psi.

ZZXX0295



* See Note

Component Number:	ZZXX0295
Specification Rev:	ECN1034
Component Weight:	264.58 Lbs.
Amount of Concrete:	0.26 Yds.
Pre-Consumer Recycle:	0.26 Lbs.
Post-Consumer Recycle:	73.24 Lbs.
CO2e Footprint:	674.91 Kgs.

* The photos shown are for product representation only. The actual products may vary in size and color depending upon application.



Product Specifications

©Playworld Systems, Inc. Wednesday, July 29, 2009

ACCESSIBLE SWING SEAT W/ GALV CHAIN TO 8FT TOP RAIL

Chain - 4/0 - galvanized

Shall be 4/0 hot dipped galvanized welded link chain. The chain links are low carbon 1008 steel. The Rockwell would be on the B scale @ 90. The working load limit for this chain is 670 lbs.

Swing Seat - Accessible (Santoprene latch)

Shall be rotationally molded from linear low density polyethylene. (See Rotationally Molded Plastic Parts) Dry-blended or molded-in color resins are not acceptable. Threaded inserts may be molded into the plastic to provide attachment points. Shall have a factory installed latching mechanism fabricated from santoprene. Santoprene is thermoplastic elastomer (TPE); hardness grade from 35 shore to 50 shore; environmental aging resistance, electrical properties, and liquid resistance. Shall contain an injection molding of ABS Plastic with a density of .0376 lb/cu inch, tensile strength 6500psi, and yield strength 7250 psi. Shall contain a 3/8" stainless steel rod.

ZZXX0224

photo
not
available

* See Note

Component Number:	ZZXX0224
Specification Rev:	PA1173
Component Weight:	25.78 Lbs.
Number of Users:	1
Pre-Consumer Recycle:	4.53 Lbs.
Post-Consumer Recycle:	2.71 Lbs.
CO2e Footprint:	0.00 Kgs.

* The photos shown are for product representation only. The actual products may vary in size and color depending upon application.

Swings - Cont.

A. Flat Seat

At 6-1/4" x 17" this is our traditional flat seat. It is extremely comfortable and withstands years of abuse. Lightweight aluminum insert provides extra strength.

- Seat only
- Seat with eyebolt

~~SRE-24
SRI-24~~

Available Color:

black

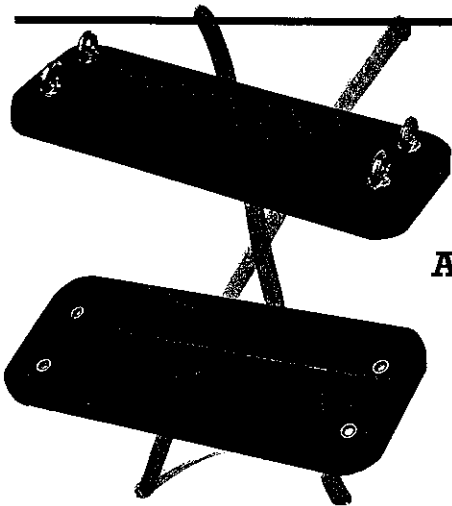

A.

B. Large Flat Seat

At 8-3/4" x 17" this is our all-age flat seat.

- Seat with A-brackets

~~SRE-12A~~

Available Color:

black

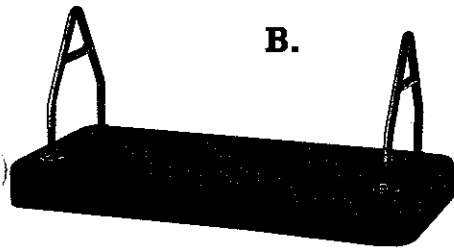

B.

C. Mega Flat Seat

At 9-1/2" x 20" this is the largest flat seat in the line.

- Seat only
- Seat with A-brackets

~~SRE-18
SRE-18A~~

Available Color:

black

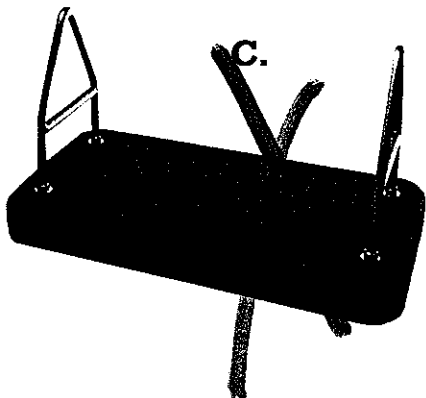

C.

**Sutcliffe
Leisure**

*Child Works® is your exclusive U.S. distributor
for the United Kingdom's Sutcliffe Leisure!*

*Vulcanized black rubber seats feature a unique cellular
construction, which dramatically absorbs impact.*