



State of West Virginia
 Department of Administration
 Purchasing Division
 2019 Washington Street East
 Post Office Box 50130
 Charleston, WV 25305-0130

Request for Quotation

RFQ NUMBER
DEP14908

PAGE
1

ADDRESS CORRESPONDENCE TO ATTENTION OF
CHUCK BOWMAN 304-558-2157

PROPERTY OF STATE

RFQ COPY

TYPE NAME/ADDRESS HERE

RBS Inc
 PO Box 490
 White Sulphur Springs WV
 24986

SHIP TO

ENVIRONMENTAL PROTECTION
 DEPT. OF
 OFFICE OF SPECIAL RECLAMATION
 105 S. RAILROAD STREET
 PHILIPPI, WV
 26416-9998 304-457-3219

DATE PRINTED	TERMS OF SALE	SHIP VIA	F.O.B.	FREIGHT TERMS
02/17/2010				

BID OPENING DATE: 04/20/2010 BID OPENING TIME 01:30PM

LINE	QUANTITY	UOP	CAT NO	ITEM NUMBER	UNIT PRICE	AMOUNT
0001	1	JB		962-73		382,140 ⁰⁰
<p>RECLAMATION: RESTORATION OF LAND</p> <p>THE WEST VIRGINIA PURCHASING DIVISION, FOR THE AGENCY, THE WEST VIRGINIA DEPARTMENT OF ENVIRONMENTAL PROTECTION, IS SOLICITING BIDS FROM QUALIFIED CONTRACTORS FOR A CONTRACT TO PROVIDE ALL LABOR AND MATERIALS TO PERFORM RECLAMATION ON THE MINING OPERATION OF TYGART VALLEY MINING, INC., NOW UNDER REVOKED PERMIT NUMBER(S) U-2002-95, ON A SITE CONSISTING OF APPROXIMATELY 17 ACRES LOCATED NEAR GALLOWAY, WV, (BARBOUR CO.).</p> <p>THE RECLAMATION SHALL BE PERFORMED UNDER THE GUIDANCE AND GENERAL SUPERVISION OF THE AGENT ASSIGNED TO THE PROJECT FOR THE STATE OF WEST VIRGINIA, DEPARTMENT OF ENVIRONMENTAL PROTECTION.</p> <p>A MANDATORY ON-SITE PREBID CONFERENCE SHALL BE HELD ON 03/23/2010 @ 10:00 AM. ALL INTERESTED PARTIES ARE REQUIRED TO ATTEND THIS MEETING. FAILURE TO ATTEND THE MANDATORY PRE-BID SHALL RESULT IN DISQUALIFICATION OF THE BID. NO ONE PERSON MAY REPRESENT MORE THAN ONE BIDDER.</p> <p>AN ATTENDANCE SHEET WILL BE MADE AVAILABLE FOR ALL POTENTIAL BIDDERS TO COMPLETE. THIS WILL SERVE AS THE OFFICIAL DOCUMENT VERIFYING ATTENDANCE AT THE MANDATORY PRE-BID. FAILURE TO PROVIDE YOUR COMPANY AND REPRESENTATIVE NAME ON THE ATTENDANCE SHEET WILL RESULT IN DISQUALIFICATION OF THE BID. THE STATE WILL NOT ACCEPT ANY OTHER DOCUMENTATION TO VERIFY ATTENDANCE. THE BIDDER IS RESPONSIBLE FOR ENSURING THEY HAVE COMPLETED THE INFOR</p>						

RECEIVED
 2010 APR 20 AM 11:53
 WV PURCHASING DIVISION

SEE REVERSE SIDE FOR TERMS AND CONDITIONS		
SIGNATURE 	TELEPHONE (304) 645-2277	DATE 16 April 10
TITLE VP, RBS Inc	FEIN 55 0477166	ADDRESS CHANGES TO BE NOTED ABOVE

WHEN RESPONDING TO RFQ, INSERT NAME AND ADDRESS IN SPACE ABOVE LABELED 'VENDOR'

**GENERAL TERMS & CONDITIONS
REQUEST FOR QUOTATION (RFQ) AND REQUEST FOR PROPOSAL (RFP)**

1. Awards will be made in the best interest of the State of West Virginia.
2. The State may accept or reject in part, or in whole, any bid.
3. Prior to any award, the apparent successful vendor must be properly registered with the Purchasing Division and have paid the required \$125 fee.
4. All services performed or goods delivered under State Purchase Order/Contracts are to be continued for the term of the Purchase Order/Contracts, contingent upon funds being appropriated by the Legislature or otherwise being made available. In the event funds are not appropriated or otherwise available for these services or goods this Purchase Order/Contract becomes void and of no effect after June 30.
5. Payment may only be made after the delivery and acceptance of goods or services.
6. Interest may be paid for late payment in accordance with the *West Virginia Code*.
7. Vendor preference will be granted upon written request in accordance with the *West Virginia Code*.
8. The State of West Virginia is exempt from federal and state taxes and will not pay or reimburse such taxes.
9. The Director of Purchasing may cancel any Purchase Order/Contract upon 30 days written notice to the seller.
10. The laws of the State of West Virginia and the *Legislative Rules* of the Purchasing Division shall govern the purchasing process.
11. Any reference to automatic renewal is hereby deleted. The Contract may be renewed only upon mutual written agreement of the parties.
12. **BANKRUPTCY:** In the event the vendor/contractor files for bankruptcy protection, the State may deem this contract null and void, and terminate such contract without further order.
13. **HIPAA BUSINESS ASSOCIATE ADDENDUM:** The West Virginia State Government HIPAA Business Associate Addendum (BAA), approved by the Attorney General, is available online at www.state.wv.us/admin/purchase/vrc/hipaa.htm and is hereby made part of the agreement. Provided that the Agency meets the definition of a Cover Entity (45 CFR §160.103) and will be disclosing Protected Health Information (45 CFR §160.103) to the vendor.
14. **CONFIDENTIALITY:** The vendor agrees that he or she will not disclose to anyone, directly or indirectly, any such personally identifiable information or other confidential information gained from the agency, unless the individual who is the subject of the information consents to the disclosure in writing or the disclosure is made pursuant to the agency's policies, procedures, and rules. Vendor further agrees to comply with the Confidentiality Policies and Information Security Accountability Requirements, set forth in <http://www.state.wv.us/admin/purchase/privacy/noticeConfidentiality.pdf>.
15. **LICENSING:** Vendors must be licensed and in good standing in accordance with any and all state and local laws and requirements by any state or local agency of West Virginia, including, but not limited to, the West Virginia Secretary of State's Office, the West Virginia Tax Department, and the West Virginia Insurance Commission. The vendor must provide all necessary releases to obtain information to enable the director or spending unit to verify that the vendor is licensed and in good standing with the above entities.
16. **ANTITRUST:** In submitting a bid to any agency for the State of West Virginia, the bidder offers and agrees that if the bid is accepted the bidder will convey, sell, assign or transfer to the State of West Virginia all rights, title and interest in and to all causes of action it may now or hereafter acquire under the antitrust laws of the United States and the State of West Virginia for price fixing and/or unreasonable restraints of trade relating to the particular commodities or services purchased or acquired by the State of West Virginia. Such assignment shall be made and become effective at the time the purchasing agency tenders the initial payment to the bidder.

I certify that this bid is made without prior understanding, agreement, or connection with any corporation, firm, limited liability company, partnership, or person or entity submitting a bid for the same material, supplies, equipment or services and is in all respects fair and without collusion or fraud. I further certify that I am authorized to sign the certification on behalf of the bidder or this bid.

INSTRUCTIONS TO BIDDERS

1. Use the quotation forms provided by the Purchasing Division. Complete all sections of the quotation form.
2. Items offered must be in compliance with the specifications. Any deviation from the specifications must be clearly indicated by the bidder. Alternates offered by the bidder as **EQUAL** to the specifications must be clearly defined. A bidder offering an alternate should attach complete specifications and literature to the bid. The Purchasing Division may waive minor deviations to specifications.
3. Unit prices shall prevail in case of discrepancy. All quotations are considered F.O.B. destination unless alternate shipping terms are clearly identified in the quotation.
4. All quotations must be delivered by the bidder to the office listed below prior to the date and time of the bid opening. Failure of the bidder to deliver the quotations on time will result in bid disqualifications: Department of Administration, Purchasing Division, 2019 Washington Street East, P.O. Box 50130, Charleston, WV 25305-0130
5. Communication during the solicitation, bid, evaluation or award periods, except through the Purchasing Division, is strictly prohibited (W.Va. C.S.R. §148-1-6.6).



State of West Virginia
 Department of Administration
 Purchasing Division
 2019 Washington Street East
 Post Office Box 50130
 Charleston, WV 25305-0130

**Request for
 Quotation**

RFQ NUMBER
DEP14908

PAGE
2

ADDRESS CORRESPONDENCE TO ATTENTION OF
CHUCK BOWMAN 304-558-2157

PROPERTY

RFQ COPY
 TYPE NAME/ADDRESS HERE

RBS Inc
 Po Box 490
 White Sulphur Springs WV
 24986

SHIP TO

ENVIRONMENTAL PROTECTION
 DEPT. OF
 OFFICE OF SPECIAL RECLAMATION
 105 S. RAILROAD STREET
 PHILIPPI, WV
 26416-9998 304-457-3219

DATE PRINTED	TERMS OF SALE	SHIP VIA	FOB	FREIGHT TERMS
02/17/2010				

BID OPENING DATE

04/20/2010

BID OPENING TIME

01:30PM

LINE	QUANTITY	UOP	CAT NO	ITEM NUMBER	UNIT PRICE	AMOUNT
<p>MATION REQUIRED ON THE ATTENDANCE SHEET. THE PURCHASING DIVISION AND THE STATE AGENCY WILL NOT ASSUME ANY RESPONSIBILITY FOR A BIDDER'S FAILURE TO COMPLETE THE PRE-BID ATTENDANCE SHEET. IN ADDITION, WE REQUEST THAT ALL POTENTIAL BIDDERS INCLUDE THEIR E-MAIL ADDRESS AND FAX NUMBER.</p> <p>ALL POTENTIAL BIDDERS ARE REQUESTED TO ARRIVE PRIOR TO THE STARTING TIME FOR THE PRE-BID. BIDDERS WHO ARRIVE LATE, BUT PRIOR TO THE DISMISSAL OF THE TECHNICAL PORTION OF THE PRE-BID WILL BE PERMITTED TO SIGN IN. BIDDERS WHO ARRIVE AFTER CONCLUSION OF THE TECHNICAL PORTION OF THE PRE-BID, BUT DURING ANY SUBSEQUENT PART OF THE PRE-BID WILL NOT BE PERMITTED TO SIGN THE ATTENDANCE SHEET.</p> <p>DIRECTIONS TO PRE-BID: IN BARBOUR COUNTY, FROM THE INTERSECTION OF SR 76 AND US ROUTE 119/250, TURN ONTO SR 76 AND GO 1.8 MILES. TURN LEFT ONTO CR 18 (PATSEY'S STORE ROAD) AND TRAVEL 0.9 MILE TO THE HAULROAD ON THE RIGHT.</p> <p>ALL WORK MUST BE COMPLETED IN ACCORDANCE WITH THE PLANS AND SPECIFICATIONS PREPARED BY THE DEPARTMENT OF ENVIRONMENTAL PROTECTION AND PURCHASE ORDER ISSUED BY THE DEPARTMENT OF ADMINISTRATION, DIVISION OF PURCHASING.</p> <p>EXHIBIT 5</p> <p>WEST VIRGINIA CODE 21-1D-5 PROVIDES THAT: ANY SOLICITATION FOR A PUBLIC IMPROVEMENT CONSTRUCTION CONTRACT REQUIRES EACH VENDOR THAT SUBMITS A BID FOR THE WORK TO SUBMIT AT THE SAME TIME AN AFFIDAVIT OF COMPLIANCE WITH THE BID. THE ENCLOSED PURCHASING AFFIDAVIT MUST BE SIGNED AND SUBMITTED WITH THE BID AS EVIDENCE OF THE VENDOR'S COMPLIANCE WITH THE PROVISIONS OF ARTICLE 1D,</p>						

SEE REVERSE SIDE FOR TERMS AND CONDITIONS

SIGNATURE	TELEPHONE	DATE
	(304) 645-2277	

TITLE	FEIN	ADDRESS CHANGES TO BE NOTED ABOVE

WHEN RESPONDING TO RFQ, INSERT NAME AND ADDRESS IN SPACE ABOVE LABELED 'VENDOR'



State of West Virginia
 Department of Administration
 Purchasing Division
 2019 Washington Street East
 Post Office Box 50130
 Charleston, WV 25305-0130

Request for Quotation

RFQ NUMBER
DEP14908

PAGE
3

ADDRESS CORRESPONDENCE TO ATTENTION OF
CHUCK BOWMAN 304-558-2157

VENDOR

RFQ COPY
 TYPE NAME/ADDRESS HERE
 RBS Inc
 PO Box 490
 White Sulphur Springs WV
 24986

SHIP TO

ENVIRONMENTAL PROTECTION
 DEPT. OF
 OFFICE OF SPECIAL RECLAMATION
 105 S. RAILROAD STREET
 PHILIPPI, WV
 26416-9998 304-457-3219

DATE PRINTED	TERMS OF SALE	SHIP VIA	FOB	FREIGHT TERMS
02/17/2010				

BID OPENING DATE: 04/20/2010 BID OPENING TIME 01:30PM

LINE	QUANTITY	UOP	CAT NO	ITEM NUMBER	UNIT PRICE	AMOUNT
<p>CHAPTER 21 OF THE WEST VIRGINIA CODE. FAILURE TO SUBMIT THE SIGNED PURCHASING AFFIDAVIT WITH THE BID SHALL RESULT IN DISQUALIFICATION OF SUCH BID.</p> <p>NOTICE TO PROCEED: THIS CONTRACT IS TO BE PERFORMED WITH 365 CALENDAR DAYS AFTER THE NOTICE TO PROCEED IS RECEIVED. UNLESS OTHERWISE SPECIFIED, THE FULLY EXECUTED PURCHASE ORDER WILL BE CONSIDERED NOTICE TO PROCEED.</p> <p>CANCELLATION: THE DIRECTOR OF PURCHASING RESERVES THE RIGHT TO CANCEL THIS CONTRACT IMMEDIATELY UPON WRITTEN NOTICE TO THE VENDOR IF THE MATERIALS OR WORKMANSHIP SUPPLIED ARE OF AN INFERIOR QUALITY OR DO NOT CONFORM WITH THE SPECIFICATIONS OF THE THE BID AND CONTRACT HERE IN.</p> <p>WAGE RATES: THE CONTRACTOR OR SUBCONTRACTOR SHALL PAY THE HIGHER OF THE U.S. DEPARTMENT OF LABOR MINIMUM WAGE RATES AS ESTABLISHED FOR BARBOUR COUNTY, PURSUANT TO WEST VIRGINIA CODE 21-5A, ET, SEQ. (PREVAILING WAGE RATES APPLY TO THIS PROJECT)</p> <p>ARBITRATION: ANY REFERENCES MADE TO ARBITRATION OR INTEREST FOR PAYMENTS DUE (EXCEPT FOR ANY INTEREST REQUIRED BY STATE LAW) CONTAINED IN THIS CONTRACT OR IN ANY AMERICAN INSTITUTE OF ARCHITECTS DOCUMENTS PERTAINING TO THIS CONTRACT ARE HEREBY DELETED.</p> <p>WORKERS' COMPENSATION: VENDOR IS REQUIRED TO PROVIDE A CERTIFICATE FROM WORKERS' COMPENSATION IF SUCCESSFUL.</p> <p>ALL OF THE ITEMS CHECKED BELOW WILL BE A REQUIREMENT OF THIS CONTRACT:</p> <p>(XX) INSURANCE: SUCCESSFUL VENDOR SHALL FURNISH PROOF</p>						

SIGNATURE		TELEPHONE	DATE
		(304) 645-2277	
TITLE	FEIN	ADDRESS CHANGES TO BE NOTED ABOVE	

WHEN RESPONDING TO RFQ, INSERT NAME AND ADDRESS IN SPACE ABOVE LABELED 'VENDOR'



State of West Virginia
 Department of Administration
 Purchasing Division
 2019 Washington Street East
 Post Office Box 50130
 Charleston, WV 25305-0130

Request for Quotation

RFQ NUMBER
DEP14908

PAGE
4

ADDRESS CORRESPONDENCE TO ATTENTION OF
CHUCK BOWMAN 304-558-2157

VENDOR

RFQ COPY
TYPE NAME/ADDRESS HERE

RBS Inc
PO Box 490
White Sulphur Springs WV
24986

SHIP TO

ENVIRONMENTAL PROTECTION
DEPT. OF
OFFICE OF SPECIAL RECLAMATION
105 S. RAILROAD STREET
PHILIPPI, WV
26416-9998 304-457-3219

DATE PRINTED	TERMS OF SALE	SHIP VIA	F.O.B.	FREIGHT TERMS
02/17/2010				

BID OPENING DATE: 04/20/2010 BID OPENING TIME 01:30PM

LINE	QUANTITY	UOP	CAT NO	ITEM NUMBER	UNIT PRICE	AMOUNT
<p>OF COMMERCIAL GENERAL LIABILITY INSURANCE PRIOR TO ISSUANCE OF CONTRACT. UNLESS OTHERWISE SPECIFIED IN THE BID DOCUMENTS, THE MINIMUM AMOUNT OF INSURANCE COVERAGE REQUIRED IS \$250,000.</p> <p>() BUILDERS RISK INSURANCE: SUCCESSFUL VENDOR SHALL FURNISH PROOF OF BUILDERS RISK - ALL RISK INSURANCE IN AN AMOUNT EQUAL TO 100% OF THE AMOUNT OF THE CONTRACT.</p> <p>(XX) BONDS: FIVE PERCENT (5%) OF THE TOTAL AMOUNT OF THE BID PAYABLE TO THE STATE OF WEST VIRGINIA, SHALL BE SUBMITTED WITH EACH BID AS A BID BOND. THE SUCCESSFUL BIDDER SHALL ALSO FURNISH A PERFORMANCE BOND AND LABOR/MATERIAL BOND FOR 100% OF THE AMOUNT OF THE CONTRACT. BONDS MAY BE PROVIDED IN THE FORM OF A CERTIFIED CHECK, IRREVOCABLE LETTER OF CREDIT, OR BOND FURNISHED BY A SOLVENT SURETY COMPANY AUTHORIZED TO DO BUSINESS IN THE STATE OF WEST VIRGINIA. A LETTER OF CREDIT SUBMITTED IN LIEU OF A BOND WILL ONLY BE ALLOWED FOR PROJECTS UNDER \$100,000. PERSONAL OR BUSINESS CHECKS ARE NOT ACCEPTABLE IN LIEU OF THE 5% BID BOND, PERFORMANCE BOND, OR LABOR AND MATERIAL BOND.</p> <p>() MAINTENANCE BOND: A TWO (2) YEAR MAINTENANCE BOND COVERING THE ROOFING SYSTEM WILL BE A REQUIREMENT OF THE SUCCESSFUL VENDOR.</p> <p>REV. 11/00</p> <p>CONTRACTORS LICENSE</p> <p>WEST VIRGINIA STATE CODE 21-11-2 REQUIRES THAT ALL PERSONS DESIRING TO PERFORM CONTRACTING WORK IN THIS STATE MUST BE LICENSED. THE WEST VIRGINIA CONTRACTORS LICENSING BOARD IS EMPOWERED TO ISSUE THE CONTRACTORS</p>						

SEE REVERSE SIDE FOR TERMS AND CONDITIONS

SIGNATURE	TELEPHONE (304) 645-2277	DATE
TITLE	FEIN	ADDRESS CHANGES TO BE NOTED ABOVE

WHEN RESPONDING TO RFQ, INSERT NAME AND ADDRESS IN SPACE ABOVE LABELED 'VENDOR'



State of West Virginia
 Department of Administration
 Purchasing Division
 2019 Washington Street East
 Post Office Box 50130
 Charleston, WV 25305-0130

Request for Quotation

RFQ NUMBER
 DEP14908

PAGE
 5

ADDRESS CORRESPONDENCE TO ATTENTION OF
 CHUCK BOWMAN
 304-558-2157

RFQ COPY

TYPE NAME/ADDRESS HERE

RBS Inc
 PO Box 490
 White Sulphur Springs WV
 24986

SHIP TO

ENVIRONMENTAL PROTECTION
 DEPT. OF
 OFFICE OF SPECIAL RECLAMATION
 105 S. RAILROAD STREET
 PHILIPPI, WV
 26416-9998 304-457-3219

DATE PRINTED	TERMS OF SALE	SHIP VIA	FOB	FREIGHT TERMS
02/17/2010				

BID OPENING DATE:

04/20/2010

BID OPENING TIME 01:30PM

LINE	QUANTITY	UOP	CAT NO	ITEM NUMBER	UNIT PRICE	AMOUNT
<p>LICENSE. APPLICATIONS FOR A CONTRACTORS LICENSE MAY BE MADE BY CONTACTING THE WEST VIRGINIA DIVISION OF LABOR CAPITOL COMPLEX, BUILDING 3, ROOM 319, CHARLESTON, WV 25305. TELEPHONE: (304) 558-7890.</p> <p>WEST VIRGINIA STATE CODE 21-11-11 REQUIRES ANY PROSPECTIVE BIDDER TO INCLUDE THE CONTRACTORS LICENSE NUMBER ON THEIR BID.</p> <p>BIDDER TO COMPLETE: CONTRACTORS NAME: <u>RBS INC</u> CONTRACTORS LICENSE NO.: <u>WV001531</u></p> <p>THE SUCCESSFUL BIDDER WILL BE REQUIRED TO FURNISH A COPY OF THEIR CONTRACTORS LICENSE PRIOR TO ISSUANCE OF A PURCHASE ORDER/CONTRACT.</p> <p style="text-align: center;">APPLICABLE LAW</p> <p>THE WEST VIRGINIA STATE CODE, PURCHASING DIVISION RULES AND REGULATIONS, AND THE INFORMATION PROVIDED IN THE "REQUEST FOR QUOTATION" ISSUED BY THE PURCHASING DIVISION IS THE SOLE AUTHORITY GOVERNING THIS PROCUREMENT.</p> <p>ANY INFORMATION PROVIDED IN SPECIFICATION MANUALS, OR ANY OTHER SOURCE, VERBAL OR WRITTEN, WHICH CONTRADICTS OR ALTERS THE INFORMATION PROVIDED FROM THE SOURCES AS DESCRIBED IN THE ABOVE PARAGRAPH IS VOID AND OF NO EFFECT.</p> <p>BANKRUPTCY: IN THE EVENT THE VENDOR/CONTRACTOR FILES FOR BANKRUPTCY PROTECTION, THE STATE MAY DEEM THIS CONTRACT NULL AND VOID AND TERMINATE SUCH CONTRACT WITHOUT FURTHER ORDER.</p>						

SEE REVERSE SIDE FOR TERMS AND CONDITIONS

SIGNATURE	TELEPHONE	DATE
	(304) 645-2277	
TITLE	FEIN	ADDRESS CHANGES TO BE NOTED ABOVE

WHEN RESPONDING TO RFQ, INSERT NAME AND ADDRESS IN SPACE ABOVE LABELED 'VENDOR'



State of West Virginia
 Department of Administration
 Purchasing Division
 2019 Washington Street East
 Post Office Box 50130
 Charleston, WV 25305-0130

Request for Quotation

RFQ NUMBER
DEP14908

PAGE
6

ADDRESS CORRESPONDENCE TO ATTENTION OF
CHUCK BOWMAN 304-558-2157

VENDOR

RFQ COPY
 TYPE NAME/ADDRESS HERE

RBS Inc
 PO Box 490
 White Sulphur Springs WV
 24986

SHIP TO

ENVIRONMENTAL PROTECTION
 DEPT. OF
 OFFICE OF SPECIAL RECLAMATION
 105 S. RAILROAD STREET
 PHILIPPI, WV
 26416-9998 304-457-3219

DATE PRINTED	TERMS OF SALE	SHIP VIA	F.O.B.	FREIGHT TERMS
02/17/2010				

BID OPENING DATE: 04/20/2010 BID OPENING TIME 01:30PM

LINE	QUANTITY	UOP	CAT. NO.	ITEM NUMBER	UNIT PRICE	AMOUNT
<p>PREFERENCE FOR USE OF DOMESTIC STEEL PRODUCTS</p> <p>1. EXCEPT WHEN AUTHORIZED BY THE DIRECTOR OF THE PURCHASING DIVISION PURSUANT TO SUBSECTION 2 BELOW, NO CONTRACTOR MAY USE OR SUPPLY STEEL PRODUCTS FOR A STATE CONTRACT PROJECT OTHER THAN THOSE STEEL PRODUCTS MADE IN THE UNITED STATES. AS USED IN THIS CONTRACT,</p> <p>A. "STATE CONTRACT PROJECT" MEANS ANY ERECTION OR CONSTRUCTION OF, OR ANY ADDITION TO, ALTERATIO OF OR OTHER IMPROVEMENT TO ANY BUILDING OR STRUCTURE, INCLUDING, BUT NOT LIMITED TO, ROADS OR HIGHWAYS, OR THE INSTALLATION OF ANY HEATING OR COOLING OR VENTILATING PLANTS OR OTHER EQUIPMENT, OR THE SUPPLY OF AND MATERIALS FOR SUCH PROJECTS, PURSUANT TO A CONTRACT WITH THE STATE OF WEST VIRGINIA FOR WHICH BIDS WERE SOLICITED ON OR AFTER JUNE 6, 2001.</p> <p>B. "STEEL PRODUCTS" MEANS PRODUCTS ROLLED, FORMED, SHAPED, DRAWN, EXTRUDED, FORGED, CAST, FABRICATED OR OTHERWISE SIMILARLY PROCESSED, O PROCESSED BY A COMBINATION OF TWO OR MORE OF SUCH OPERATIONS, FROM STEEL MADE BY THE OPEN HEARTH, BASIC OXYGEN, ELECTRIC FURNACE, BESSEMER OR OTHER STEEL MAKING PROCESS.</p> <p>C. "UNITED STATES" MEANS THE UNITED STATES OF AMERICA AND INCLUDES ALL TERRITORY, CONTINENTAL OR INSULAR, SUBJECT TO THE JURISDICTION OF THE UNITED STATES.</p> <p>2. THE DIRECTOR OF THE PURCHASING DIVISION MAY, IN WRITING, AUTHORIZE THE USE OF FOREIGN STEEL</p>						

SEE REVERSE SIDE FOR TERMS AND CONDITIONS

SIGNATURE	TELEPHONE	DATE
	304 645-2277	

TITLE	FEIN	ADDRESS CHANGES TO BE NOTED ABOVE

WHEN RESPONDING TO RFQ, INSERT NAME AND ADDRESS IN SPACE ABOVE LABELED 'VENDOR'



State of West Virginia
 Department of Administration
 Purchasing Division
 2019 Washington Street East
 Post Office Box 50130
 Charleston, WV 25305-0130

Request for Quotation

RFQ NUMBER
DEP14908

PAGE
7

ADDRESS CORRESPONDENCE TO ATTENTION OF
CHUCK BOWMAN 304-558-2157

VENDOR

RFQ COPY
 TYPE NAME/ADDRESS HERE
 RBS Inc
 PO Box 490
 White Sulphur Springs WV
 24986

SHIP TO

ENVIRONMENTAL PROTECTION
 DEPT. OF
 OFFICE OF SPECIAL RECLAMATION
 105 S. RAILROAD STREET
 PHILIPPI, WV
 26416-9998 304-457-3219

DATE PRINTED	TERMS OF SALE	SHIP VIA	F.O.B.	FREIGHT TERMS
02/17/2010				

BID OPENING DATE: 04/20/2010 BID OPENING TIME 01:30PM

LINE	QUANTITY	UOP	CAT NO	ITEM NUMBER	UNIT PRICE	AMOUNT
<p>PRODUCTS IF:</p> <p>A. THE COST FOR EACH CONTRACT ITEM USED DOES NOT EXCEED ONE TENTH OF ONE PERCENT (.1%) OF THE TOTAL CONTRACT COST OR TWO THOUSAND FIVE HUNDRED DOLLARS (2,500.00), WHICHEVER IS GREATER. FOR THE PURPOSES OF THIS SECTION, THE COST IS THE VALUE OF THE STEEL PRODUCT AS DELIVERED TO THE PROJECT OR,</p> <p>B. THE DIRECTOR OF THE PURCHASING DIVISION DETERMINES THAT SPECIFIED STEEL MATERIALS ARE NOT PRODUCED IN THE UNITED STATES IN SUFFICIENT QUANTITY OR OTHERWISE ARE NOT REASONABLY AVAILABLE TO MEET CONTRACT REQUIREMENTS.</p> <p>3. A CONTRACTOR WHO USES STEEL PRODUCTS IN VIOLATION OF THIS SECTION MAY BE SUBJECT TO CIVIL PENALTIES PURSUANT TO WV CODE SECTION 5A-3-56.</p> <p>REV. 10/01/01</p> <p>EXHIBIT 7</p> <p>DOMESTIC ALUMINUM, GLASS & STEEL IN PUBLIC WORKS PROJECTS</p> <p>IN ACCORDANCE WITH WEST VIRGINIA CODE 5-19-1 ET., SEQ., EVERY CONTRACT FOR CONSTRUCTION, RECONSTRUCTION, ALTERATION, REPAIR, IMPROVEMENT OR MAINTENANCE OF PUBLIC WORKS, WHERE THE COST IS MORE THAN \$50,000 AND, IN THE CASE OF STEEL ONLY, WHERE THE COST OF STEEL IS MORE THAN \$50,000 OR WHERE MORE THAN 10,000 POUNDS OF STEEL ARE REQUIRED, THE STATE WILL ACCEPT ONLY ALUMINUM, GLASS, OR STEEL PRODUCTS PRODUCED IN THE UNITED STATES</p>						

SEE REVERSE SIDE FOR TERMS AND CONDITIONS

SIGNATURE	TELEPHONE	DATE
	304 645-2277	

TITLE	FEIN	ADDRESS CHANGES TO BE NOTED ABOVE

WHEN RESPONDING TO RFQ, INSERT NAME AND ADDRESS IN SPACE ABOVE LABELED 'VENDOR'



State of West Virginia
 Department of Administration
 Purchasing Division
 2019 Washington Street East
 Post Office Box 50130
 Charleston, WV 25305-0130

Request for Quotation

RFQ NUMBER
DEP14908

PAGE
8

ADDRESS CORRESPONDENCE TO ATTENTION OF
CHUCK BOWMAN 304-558-2157

RFQ COPY

TYPE NAME/ADDRESS HERE

RBS Inc
 PO Box 490
 White Sulphur Springs WV
 24986

SHIP TO

ENVIRONMENTAL PROTECTION
 DEPT. OF
 OFFICE OF SPECIAL RECLAMATION
 105 S. RAILROAD STREET
 PHILIPPI, WV
 26416-9998 304-457-3219

DATE PRINTED	TERMS OF SALE	SHIP VIA	F.O.B.	FREIGHT TERMS
02/17/2010				

BID OPENING DATE:

04/20/2010

BID OPENING TIME

01:30PM

LINE	QUANTITY	UOP	CAT NO	ITEM NUMBER	UNIT PRICE	AMOUNT
<p>IN ADDITION, ITEMS OF MACHINERY OR EQUIPMENT PURCHASED FOR USE AT THE SITE OF PUBLIC WORKS SHALL BE MADE OF DOMESTIC ALUMINUM, GLASS OR STEEL, UNLESS THE COST OF THE PRODUCT IS LESS THAN \$50,000 OR LESS THAN 10,000 POUNDS OF STEEL ARE USED IN PUBLIC WORKS PROJECTS.</p> <p>FOREIGN MADE ALUMINUM, GLASS OR STEEL PRODUCTS MAY BE ACCEPTED ONLY IF THE COST OF DOMESTIC PRODUCTS IS FOUND TO BE UNREASONABLE. SUCH COST IS UNREASONABLE IF IT IS 20% OR MORE HIGHER THAN THE BID PRICE FOR FOREIGN MADE PRODUCTS. IF THE DOMESTIC ALUMINUM, GLASS OR STEEL PRODUCTS TO BE SUPPLIED OR PRODUCED IN A "SUBSTANTIAL LABOR SURPLUS AREA", AS DEFINED BY THE UNITED STATES DEPARTMENT OF LABOR, FOREIGN PRODUCTS MAY BE SUPPLIED ONLY IF DOMESTIC PRODUCTS ARE 30% OR MORE HIGHER IN PRICE THAN THE FOREIGN MADE PRODUCTS.</p> <p>IF, PRIOR TO THE AWARD OF A CONTRACT UNDER THE ABOVE PROVISIONS, THE SPENDING OFFICER OF THE SPENDING UNIT DETERMINES THAT THERE EXISTS A BID FOR LIKE FOREIGN ALUMINUM, GLASS OR STEEL THAT IS REASONABLE AND LOWER THAN THE LOWEST BID DOMESTIC PRODUCTS, THE SPENDING OFFICE MAY REQUEST, IN WRITING, A REEVALUATION AND REDUCTION IN THE LOWEST BID FOR SUCH DOMESTIC PRODUCTS ALL VENDORS MUST INDICATE IN THEIR BID IF THEY ARE SUPPLYING FOREIGN ALUMINUM, GLASS OR STEEL.</p> <p>REV. 3/88</p> <p>EXHIBIT 9</p> <p>NOTICE FOR ISSUANCE & ACKNOWLEDGEMENT OF CONSTRUCTION PROJECT ADDENDA</p> <p>THE ARCHITECT/ENGINEER AND/OR AGENCY SHALL BE REQUIRED TO ABIDE BY THE FOLLOWING SCHEDULE IN ISSUING</p>						

SEE REVERSE SIDE FOR TERMS AND CONDITIONS

SIGNATURE	TELEPHONE	DATE
	304 645-2277	
TITLE	FEIN	ADDRESS CHANGES TO BE NOTED ABOVE

WHEN RESPONDING TO RFQ, INSERT NAME AND ADDRESS IN SPACE ABOVE LABELED 'VENDOR'



State of West Virginia
 Department of Administration
 Purchasing Division
 2019 Washington Street East
 Post Office Box 50130
 Charleston, WV 25305-0130

Request for Quotation

RFQ NUMBER
DEP14908

PAGE
9

ADDRESS CORRESPONDENCE TO ATTENTION OF
CHUCK BOWMAN 304-558-2157

RFQ COPY
 TYPE NAME/ADDRESS HERE

VENDOR

RBS Inc
 PO Box 490
 White Sulphur Springs
 WV
 24986

SHIP TO

ENVIRONMENTAL PROTECTION
 DEPT. OF
 OFFICE OF SPECIAL RECLAMATION
 105 S. RAILROAD STREET
 PHILIPPI, WV
 26416-9998 304-457-3219

DATE PRINTED 02/17/2010	TERMS OF SALE	SHIP VIA	F.O.B.	FREIGHT TERMS
----------------------------	---------------	----------	--------	---------------

BID OPENING DATE: 04/20/2010 BID OPENING TIME 01:30PM

LINE	QUANTITY	UOP	CAT. NO.	ITEM NUMBER	UNIT PRICE	AMOUNT
<p>CONSTRUCTION PROJECT ADDENDA FOR STATE AGENCIES:</p> <p>(1) THE ARCHITECT/ENGINEER SHALL PREPARE THE ADDENDUM AND A LIST OF ALL PARTIES THAT HAVE PROCURED DRAWINGS AND SPECIFICATIONS FOR THE PROJECT. THE ADDENDUM AND LIST SHALL BE FORWARDED TO THE BUYER IN THE STATE PURCHASING DIVISION. THE ARCHITECT/ENGINEER SHALL ALSO SEND A COPY OF THE ADDENDUM TO THE STATE AGENCY FOR WHICH THE CONTRACT IS ISSUED.</p> <p>(2) THE BUYER SHALL SEND THE ADDENDUM TO ALL INTERESTED PARTIES AND, IF NECESSARY, EXTEND THE BID OPENING DATE. ANY ADDENDUM SHOULD BE RECEIVED BY THE BUYER WITHIN FOURTEEN (14) DAYS PRIOR TO THE BID OPENING DATE.</p> <p>(3) ALL ADDENDA SHOULD BE FORMALLY ACKNOWLEDGED BY ALL BIDDERS AND SUBMITTED TO THE STATE PURCHASING DIVISION. THE SAME RULES AND REGULATIONS THAT APPLY TO THE ORIGINAL BIDDING DOCUMENT SHALL ALSO APPLY TO AN ADDENDUM DOCUMENT. THE ONLY EXCEPTION MAY BE FOR AN ADDENDUM THAT IS ISSUED FOR THE SOLE PURPOSE OF CHANGING A BID OPENING TIME AND/OR DATE.</p> <p>REV. 11/96</p> <p>EXHIBIT 10</p> <p>DEP14908</p> <p>ADDENDUM ACKNOWLEDGEMENT</p> <p>I HEREBY ACKNOWLEDGE RECEIPT OF THE FOLLOWING CHECKED ADDENDUM(S) AND HAVE MADE THE NECESSARY REVISIONS TO MY PROPOSAL, PLANS AND/OR SPECIFICATION, ETC.</p>						

SEE REVERSE SIDE FOR TERMS AND CONDITIONS			
SIGNATURE	TELEPHONE (304) 605-2277	DATE	
TITLE	FEIN	ADDRESS CHANGES TO BE NOTED ABOVE	

WHEN RESPONDING TO RFQ, INSERT NAME AND ADDRESS IN SPACE ABOVE LABELED 'VENDOR'



State of West Virginia
 Department of Administration
 Purchasing Division
 2019 Washington Street East
 Post Office Box 50130
 Charleston, WV 25305-0130

**Request for
 Quotation**

RFQ NUMBER
 DEP14908

PAGE
 10

ADDRESS CORRESPONDENCE TO ATTENTION OF
 CHUCK BOWMAN
 304-558-2157

PROPERTY

RFQ COPY
 TYPE NAME/ADDRESS HERE

RBS Inc
 PO Box 490
 White Sulphur Springs
 WV 24986

SHIP TO

ENVIRONMENTAL PROTECTION
 DEPT. OF
 OFFICE OF SPECIAL RECLAMATION
 105 S. RAILROAD STREET
 PHILIPPI, WV
 26416-9998 304-457-3219

DATE PRINTED 02/17/2010	TERMS OF SALE	SHIP VIA	FOB	FREIGHT TERMS
----------------------------	---------------	----------	-----	---------------

BID OPENING DATE: 04/20/2010 BID OPENING TIME 01:30PM

LINE	QUANTITY	UOP	CAT NO	ITEM NUMBER	UNIT PRICE	AMOUNT
ADDENDUM NOS.:						
NO. 1						
NO. 2						
NO. 3						
NO. 4						
NO. 5						
<p>I UNDERSTAND THAT FAILURE TO CONFIRM THE RECEIPT OF THE ADDENDUM(S) MAY BE CAUSE FOR REJECTION OF THE BIDS.</p> <p>VENDOR MUST CLEARLY UNDERSTAND THAT ANY VERBAL REPRESENTATION MADE OR ASSUMED TO BE MADE DURING ANY ORAL DISCUSSION HELD BETWEEN VENDOR'S REPRESENTATIVES AND ANY STATE PERSONNEL IS NOT BINDING. ONLY THE INFORMATION ISSUED IN WRITING AND ADDED TO THE SPECIFICATIONS BY AN OFFICIAL ADDENDUM IS BINDING.</p> <p><i>[Signature]</i> V.P. SIGNATURE RBS Inc. COMPANY 16 April 2010 DATE</p>						
REV. 11/96						
NOTICE						
A SIGNED BID MUST BE SUBMITTED TO:						

SEE REVERSE SIDE FOR TERMS AND CONDITIONS

SIGNATURE	TELEPHONE (304) 645-2277	DATE
TITLE	FEIN	ADDRESS CHANGES TO BE NOTED ABOVE

WHEN RESPONDING TO RFQ, INSERT NAME AND ADDRESS IN SPACE ABOVE LABELED 'VENDOR'



State of West Virginia
 Department of Administration
 Purchasing Division
 2019 Washington Street East
 Post Office Box 50130
 Charleston, WV 25305-0130

Request for Quotation

RFQ NUMBER
DEP14908

PAGE
11

ADDRESS CORRESPONDENCE TO ATTENTION OF
CHUCK BOWMAN 304-558-2157

VENDOR

RFQ COPY
 TYPE NAME/ADDRESS HERE
 RBS Inc
 PO Box 490
 White Sulphur Springs WV
 24986

SHIP TO

ENVIRONMENTAL PROTECTION
 DEPT. OF
 OFFICE OF SPECIAL RECLAMATION
 105 S. RAILROAD STREET
 PHILIPPI, WV
 26416-9998 304-457-3219

DATE PRINTED	TERMS OF SALE	SHIP VIA	FOB	FREIGHT TERMS
02/17/2010				

BID OPENING DATE:

04/20/2010

BID OPENING TIME 01:30PM

LINE	QUANTITY	UOP	CAT NO	ITEM NUMBER	UNIT PRICE	AMOUNT
DEPARTMENT OF ADMINISTRATION PURCHASING DIVISION BUILDING 15 2019 WASHINGTON STREET, EAST CHARLESTON, WV 25305-0130						
THE BID SHOULD CONTAIN THIS INFORMATION ON THE FACE OF THE ENVELOPE OR THE BID MAY NOT BE CONSIDERED: SEALED BID BUYER: CB-23 REQ. NO.: DEPL4908 BID OPENING DATE: 04/20/2010 BID OPENING TIME: 1:30 P.M. PLEASE PROVIDE A FAX NUMBER IN CASE IT IS NECESSARY TO CONTACT YOU REGARDING YOUR BID: ----- 304. 645. 2277 ----- PLEASE PRINT OR TYPE NAME OF PERSON TO CONTACT CONCERNING THIS QUOTE: ----- William Snyder -----						

SEE REVERSE SIDE FOR TERMS AND CONDITIONS

SIGNATURE	TELEPHONE	DATE
	304-645-2277	
TITLE	FEIN	ADDRESS CHANGES TO BE NOTED ABOVE

WHEN RESPONDING TO RFQ, INSERT NAME AND ADDRESS IN SPACE ABOVE LABELED 'VENDOR'

Tygart Valley Mining, Inc.
Permit No. U-2002-95

CB-23 PAGE DEP 14908

LOCATION MAP

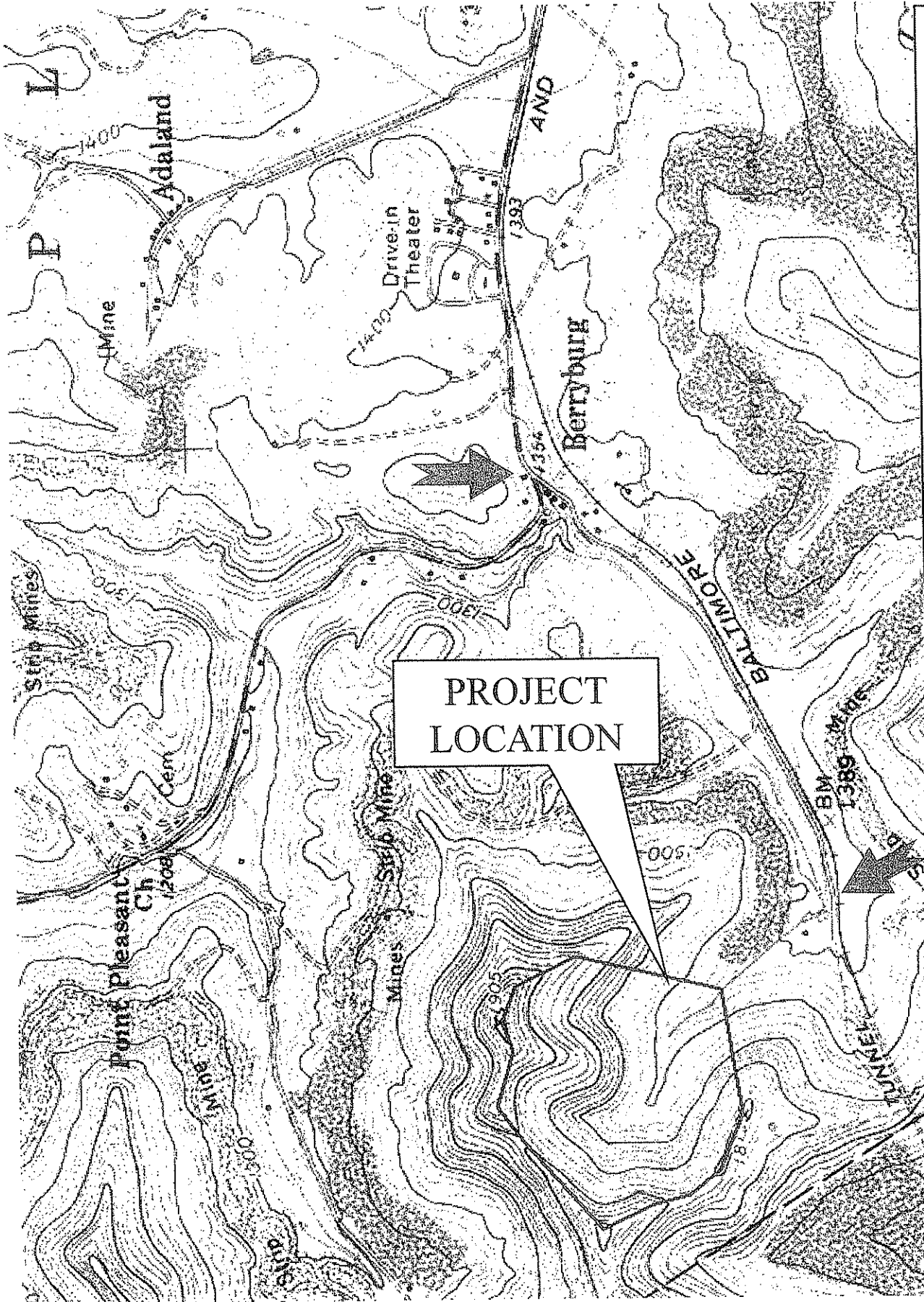

In Barbour County, from the intersection of State Route 76 and US Route 119/250, turn onto State Route 76 and go 1.8 miles. Turn left onto County Route 18 (Patsey's Store Road) and travel 0.9 miles to the haulroad on the right.

BUYER CB-23	PAGE	REQ. OR PO NO. DEP 14908
SPENDING UNIT WEST VIRGINIA DEPARTMENT OF ENVIRONMENTAL PROTECTION/SPECIAL RECLAMATION		

WV-36a STATE OF WEST VIRGINIA
REV. 5-26-09 PURCHASING CONTINUATION SHEET
VENDOR:

SCOPE OF WORK

The successful bidder shall provide appropriate equipment, materials, labor and any technical services needed for the successful partial reclamation of Tygart Valley Mining Company's, Permit U-2002-95, and any disturbance associated with such operation. The General Performance Standards (GPS) shall apply to all items in Scope of Work. Work necessary on this site will include the following items, but is not limited to these:

1. Upon mobilization to the site, which will be directed in a written Notice to Proceed, the access roads shall be developed in accordance with bid item #4.0.
2. If fuel and lubricants are to be stored on site, bid item #2.0 shall be in place before fuel is delivered. The project sign shall be obtained and installed prior to the start of any work.
3. Storm water management, as necessary, in the form as described, in the National Pollutant Discharge Elimination System, Water Pollution Control Permit Number WV1010115, existing sediment control pond and in addition bid items #6-7 shall be installed (described locations). See Water Quality Control under the General Performance Standards.
4. Check for and locate all utilities, including power lines and gas lines, within the work area to provide and maintain a safe working area in addition to preventing damage to the utility.
5. Install seep collection and drain system in mine entrance pit.
6. Remove structures and debris from site.
7. Revegetation and soil improvements are required for all non-road/ditch disturbed areas. Reclamation and backfilling is to be done according to the attached specifications, plans, and clarifying discussions at the Pre-Bid Conference.
8. Construct riprap ditches or open limestone channels.
9. Install culverts.
10. Eliminate sediment pond.
11. Any other site specific items required.

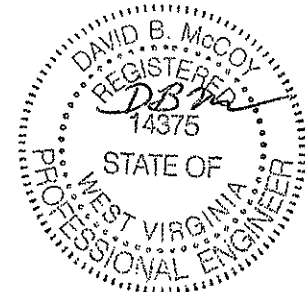

I, David B. McCoy, the undersigned, hereby certify¹ that this Reclamation Plan is correct and shows to the best of my knowledge and belief all the information required by the surface mining laws of the State of West Virginia. The source of information was the approved mining and reclamation plan contained in the forfeited surface mine permit, existing site conditions and information contained in the WV DEP, Inspection and Enforcement files.

David B. McCoy
Registered Professional Engineer WV No. 14375

Date: 1-7-2010

¹ The term "certify" as used herein is defined as follows: An engineer's certification of conditions is a declaration of professional judgment. It does not constitute a warranty or guarantee, either expressed or implied.

RBS Inc
 PO Box 490
 White Sulphur Springs WV
 24986

BUYER CB-23	PAGE	REQ. OR PO NO. DEP 14908
SPENDING UNIT WEST VIRGINIA DEPARTMENT OF ENVIRONMENTAL PROTECTION/SPECIAL RECLAMATION		

WV-36a STATE OF WEST VIRGINIA
 REV. 5-26-09 PURCHASING CONTINUATION SHEET
 VENDOR:

ITEM NO.	QUANTITY	DESCRIPTION	UNIT PRICE	AMOUNT
BID SCHEDULE				
PERMIT NAME: <u>Tygart Valley Mining Co.</u>				
PERMIT NUMBER(S): <u>U-2002-95</u>				
The DEP reserves the right to request additional information and supporting documentation regarding unit prices when the unit price appears to be unreasonable.				
1.0	LUMP SUM	<u>MOBILIZATION/DEMobilIZATION/PROJECT SIGN</u> (5% Total Bid Maximum for this permit)	LUMP SUM	\$ <u>15,000⁰⁰</u>
2.0	LUMP SUM	<u>SPILL CONTAINMENT AREA (S.C.A.)</u> (\$1,000.00 Maximum Bid for this permit)	LUMP SUM	\$ <u>500⁰⁰</u>
3.0	NO BID ITEM	<u>UTILITIES</u>	NO BID ITEM	NO BID ITEM
4.0	<u>1500 LF</u>	<u>HAULROAD/ACCESS ROAD UPGRADE</u>	\$ <u>10.⁰⁰</u> PER LF	\$ <u>15,000⁰⁰</u>
5.0	<u>600 TON</u>	<u>INCIDENTAL STONE</u>	\$ <u>25.⁰⁰</u> PER TON	\$ <u>15,000⁰⁰</u>
6.0	<u>1000 LF</u>	<u>SEDIMENT CONTROL WITH SILT FENCE AND HAYBALE DIKE</u> (Max. Bid \$5.00 Per LF)	\$ <u>2.⁰⁰</u> PER LF	\$ <u>2,000⁰⁰</u>
7.0	<u>2 EA</u>	<u>CONSTRUCTED SEDIMENT CONTROL STRUCTURES</u>	\$ <u>1,000⁰⁰</u> PER EA	\$ <u>2,000⁰⁰</u>
8.0	LUMP SUM	<u>CLEAR AND GRUB</u>	LUMP SUM	\$ <u>10,000⁰⁰</u>
9.0	<u>600 LF</u>	<u>UNDERDRAIN</u>	\$ <u>47.⁰⁰</u> PER LF	\$ <u>28,200⁰⁰</u>
10.0	<u>160 TON</u>	<u>LIMING</u>	\$ <u>25.⁰⁰</u> PER TON	\$ <u>4,000⁰⁰</u>
11.0	LUMP SUM	<u>BACKFILLING</u>	LUMP SUM	\$ <u>143,000⁰⁰</u>
12.0	LUMP SUM	<u>REGRAIDING AND TOPSOILING</u>	LUMP SUM	\$ <u>13,000⁰⁰</u>
13.0	<u>1800 LF</u>	<u>TRAPEZOIDAL DITCH - 16'</u>	\$ <u>45.⁰⁰</u> PER LF	\$ <u>81,000⁰⁰</u>
14.0	<u>1400 LF</u>	<u>V-DITCH - 4'</u>	\$ <u>14.⁰⁰</u> PER LF	\$ <u>19,600⁰⁰</u>

RBS Inc
 PO Box 490
 White Sulphur Springs WV
 24986

BUYER CB-23	PAGE	REQ. OR PO NO. DEP 14908
SPENDING UNIT WEST VIRGINIA DEPARTMENT OF ENVIRONMENTAL PROTECTION/SPECIAL RECLAMATION		

WV-36a STATE OF WEST VIRGINIA
 REV. 5-26-09 PURCHASING CONTINUATION SHEET
 VENDOR:

ITEM NO.	QUANTITY	DESCRIPTION	UNIT PRICE	AMOUNT
15.0	LUMP SUM	<u>STRUCTURE / DEBRIS REMOVAL</u>	LUMP SUM	\$ <u>2,000⁰⁰</u>
16.0	LUMP SUM	<u>SEDIMENT POND ELIMINATION</u>	LUMP SUM	\$ <u>3,000⁰⁰</u>
17.0	LUMP SUM	<u>POND EXIT CLEANING & MODIFICATION</u>	LUMP SUM	\$ <u>3,000⁰⁰</u>
18.0		<u>REVEGETATION</u>		
18.1	<u>17 AC</u>	<u>AGRICULTURAL LIME</u>	\$ <u>500⁰⁰</u> PER AC	\$ <u>8,500⁰⁰</u>
18.2	<u>17 AC</u>	<u>FERTILIZER</u>	\$ <u>350⁰⁰</u> PER AC	\$ <u>5,950⁰⁰</u>
18.3	<u>17 AC</u>	<u>MULCH</u>	\$ <u>440⁰⁰</u> PER AC	\$ <u>7,480⁰⁰</u>
18.4	<u>17 AC</u>	<u>VEGETATIVE SPECIES</u>	\$ <u>230⁰⁰</u> PER AC	\$ <u>3,910⁰⁰</u>
TOTAL FOR PERMIT <u>U-2002-95</u>				\$ <u>382,140⁰⁰</u>

BUYER CB-23	PAGE	REQ. OR PO NO. DEP 14908
SPENDING UNIT WEST VIRGINIA DEPARTMENT OF ENVIRONMENTAL PROTECTION/SPECIAL RECLAMATION		

WV-36a STATE OF WEST VIRGINIA
REV. 5-26-09 PURCHASING CONTINUATION SHEET
VENDOR:

BID ITEM TECHNICAL SPECIFICATIONS

1.0 MOBILIZATION/DEMobilIZATION/PROJECT SIGN

A project sign shall be obtained or manufactured and installed as indicated on the attached specifications and details. Payment for this sign shall be incidental to the mobilization item. No separate payment will be made.

This work shall consist of the performance of construction preparatory operations, including the movement of personnel, equipment and other facilities to the project site necessary to begin work on a substantial phase of the contract.

Prior to demobilization, an inspection shall be conducted by the Department of Environmental Protection and the contractor to insure compliance with contract performance. Once compliance is ascertained, demobilization activities can be initiated and completed. Demobilization shall be totally completed before the invoice for payment shall be processed.

The lump sum bid for this item shall not exceed 5% of the total bid for this permit. Payment shall be made in two 50% amounts, one upon completion of the mobilization and project sign items and the second payment at the completion of demobilization. No deduction shall be made nor shall any increase be made in the lump sum item amount, regardless of decreases or increases in the final total contract amount or any other reason.

2.0 SPILL CONTAINMENT AREA (S.C.A.)

Spill containment measures shall be used for fuel and lubricant storage areas. All containers, barrels, buckets, cans, etc., are to be legally disposed of off site. Used lubricants are to be disposed of according to state law to minimize pollution to the local surface and ground water supplies. Spills are the responsibility of the contractor and need immediate clean up and maintained at no expense to the State. This S.C.A. shall be constructed in accordance with the typical drawing specification. (See Attachment) Alternate containment measures will be considered for approval by the Program Manager if acceptable results can be shown. Fuel tanks manufactured with secondary containment are desirable. Minimum secondary containment is 110 percent. (Bid limited to \$1,000.00 maximum)

3.0 UTILITIES

Utilities shall be relocated at the direction of the utility company and reimbursed actual cost to the contractor. This is a "No Bid" item due to the method of reimbursement. It is the contractor's responsibility to determine the exact location of each utility in the project area where these utilities would be interrupted or damaged by performing work. Known utilities include power poles and lines to be removed, as well as a gas line crossing underneath the haulroad.

4.0 HAULROAD/ACCESS ROAD UPGRADE

The contractor shall maintain and/or construct haul-road/access road during the reclamation process to provide access on a well drained surface. The access road to and on the reclamation site shall be graded, sloped, and maintained to drain to provide a road surface free of excessive mud and standing waters at all times while work is in progress. Upon completion of all reclamation activities, a final 3 inch layer of 1 ½ crusher run limestone shall be placed on the roadway. Roads which are below the project shall be guarded against rolling rock and removal of rocks done as necessary. Dust-control measures may be necessary if hauling creates airborne material. Snow removal is to be included in this item.

Access to gas well above the pit must be maintained via the road around the north side of the site. Sections of the existing haulroad and access road will need to be cut down for access to backfilling spoil, and may need to be re-aligned. Contractor and Inspector shall decide on best final road alignment.

5.0 INCIDENTAL STONE

During construction of culvert installations, roadway ditch improvements, and reshaping of the roadway, areas may need additional base layer stone. After any necessary re-compaction and re-grading work on roadways has been performed by the contractor, a six (6) inch layer of #1 limestone (3.5" to 1.5" size) shall be placed as needed.

BUYER CB-23	PAGE	REQ. OR PO NO. DEP 14908
SPENDING UNIT WEST VIRGINIA DEPARTMENT OF ENVIRONMENTAL PROTECTION/SPECIAL RECLAMATION		

WV-36a STATE OF WEST VIRGINIA
REV. 5-26-09 PURCHASING CONTINUATION SHEET
VENDOR:

This stone shall be graded and tracked in with a dozer or other equipment to achieve a compacted base for the final top layer of 1 ½ inch crusher run limestone (separate bid item).

Payment shall be paid per ton of stone applied by weight ticket and will be made at completion of all work and acceptance by DEP.

6.0 SEDIMENT CONTROL WITH SILT FENCE AND HAYBALE DIKE

Disturbed areas which have storm water runoff and does not pass through a sediment control structure shall utilize the following Best Management Practice (BMP) methods to manage storm water runoff. For more information on BMP methods go to the WVDEP website <http://www.wvdep.org/dwvm/stormwater/BMP.htm> and click on **BMP Manual**. The WV Erosion and Sediment Control Best Management Practice Manual may be accessed or printed. This item has a Maximum Bid of \$5.00/LF of silt fence and hay bale material used on site.

1. Silt fence shall be utilized on perimeter barriers and shall be properly removed after permanent vegetation has been established. See attached drawing for further details.
2. For slope stability, place bales on the contour; at the top of cuts; and at the toe of slopes. Bales shall be placed in a row with ends tightly abutting the adjacent bales.
3. Bales shall be securely anchored in place by stakes or rebars driven through the bales. Rebar to be removed at the direction of DEP. The first stake in each bale shall be driven toward previously laid bale to force the bales together.
4. Construction of sediment control sumps before culvert inlets and/or rock check dams in ditch lines may become necessary to supplement the silt fence and hay bale dikes. These items shall be installed upon request of the DEP onsite representative. Sumps and rock check dams shall be incidental to this bid item.

7.0 CONSTRUCTED SEDIMENT CONTROL STRUCTURES

Sediment control structures shall be constructed as per attached detailed plans. Such structures shall be cleaned out when the sediment capacity reaches 60%, repaired, and maintained until demobilization. This item will be a one-time payment. Clean-out and maintenance shall be conducted by the contractor at no expense to DEP. (SEE ATTACHMENT)

8.0 CLEAR AND GRUB

All vegetative cover (trees, shrubs, bushes etc.) within the entire work area shall be removed to bare ground. It is the contractor's responsibility to obtain all necessary permits and to follow state guidelines for burning and proper disposal of vegetative materials. Disposal of the trees and shrubs on-site with a chipper is an acceptable alternative to burning. A majority of the area, where the passive treatment system will be constructed, is on private property; therefore, it is imperative that the contractor in conjunction with the on-site DEP representative cooperate with the landowner to identify construction limits and property lines. Any timber cut in the clear and grub area that the landowner wishes to retain shall be de-limbed and stockpiled.

9.0 UNDERDRAIN

Collection underdrains shall be constructed to collect all seep water for conveyance to the mine portal. The collection underdrain shall be 4 ft. X 4 ft. in cross-section. Stone for the underdrain shall be non-calcareous with a size of 3" to 6" in diameter. The drain shall be wrapped with filter fabric (Tyvar 3401 or equivalent). Filter fabric may be omitted from areas where the seepage enters the underdrain if approved by the DEP on site representative. A 12" perforated SDR-35 PVC pipe shall extend the length of the underdrain and connect to solid pipe. The solid pipe shall extend at least 40 feet into the mine portal. The solid 12 inch SDR-35 pipe shall be incidental to this bid item.

BUYER CB-23	PAGE	REQ. OR PO NO. DEP 14908
SPENDING UNIT WEST VIRGINIA DEPARTMENT OF ENVIRONMENTAL PROTECTION/SPECIAL RECLAMATION		

WV-36a STATE OF WEST VIRGINIA
REV. 5-26-09 PURCHASING CONTINUATION SHEET
VENDOR:

Provide all fittings necessary for installation. Refer to the attached drawing for further details. All materials specified above and on the attached drawing shall be incidental to this bid item. Payment for each underdrain is for complete installation and verified by DEP with photo.

10.0 LIMING

Liming of open pits is to be carried out at a rate of 40 tons/acre. All potentially toxic material shall be cleaned from the pavement prior to spreading lime uniformly over the exposed pavement. This potentially toxic material shall be placed on a pad prepared in the backfill. The top of the pad shall be a minimum of 4 ft. above the pavement, located out of any water course and away from the highwall. Lime shall be blended with the toxic material or (lime shall be spread over top of toxic material.) Coal refuse shall be treated in the same manner as the toxic material above and according to the attached specifications. Lime at a rate of 40 tons/1000 tons. (Unless exact tons are specified in the Scope of Work)

Unless otherwise specified, all lime used shall be registered with the West Virginia Department of Agriculture, have an 85% minimum calcium carbonate equivalent, and meet the fineness classification no larger than that for ground. The following fineness classifications or combinations of are acceptable:

- Pulverized - 100% passing a U.S. Standard 20 mesh sieve
- 70% passing a U.S. Standard 100 mesh sieve
- Ground - 90% passing a U.S. Standard 20 mesh sieve
- 50% passing a U.S. Standard 60 mesh sieve
- 35% passing a U.S. Standard 100 mesh sieve

Use of blends and low-grade agricultural liming materials shall require prior approval. Lime shall be spread as soon as possible after delivery to site. Lime shall be applied evenly and uniformly distributed over the treated area. Lime shall be thoroughly mixed into the soil material. Lime subjected to adverse conditions before spreading will be deemed unacceptable. Failure to complete this phase shall result in nonpayment of this bid item.

11.0 BACKFILLING

Areas of this project subject to backfilling to achieve the post-mining land-use shall: be accomplished in a continuous concurrent manner on all surface disturbances within the original permit and associated disturbed areas as existing at bid showing; be filled by mechanical methods to eliminate highwall and rock outcropping, to produce slopes of consistent lines and of the approximate original contour; be free of protruding rock and debris; be compacted in a progressive backfilling manner with mechanical equipment to ensure stability of backfill material. The maximum acceptable slope of any backfill face shall not exceed two (2) horizontal to one (1) vertical, unless otherwise stated. Backfilling shall cease during periods of adverse site conditions (for example: excessive soil moisture).

Black/grey material in coal pad area shall be mixed with lime as per the previous bid item, and isolated in the backfill such that it is off the pit floor, and above the underdrains. All possible measures should be taken to minimize the potential for this material to be exposed to water or air. Any other potentially acid-producing material found in the fill shall also be treated in this fashion.

12.0 REGRADE AND TOPSOILING

Concurrent regrading and topsoiling shall immediately follow backfilling and shall distribute topsoil or the best available material to support vegetation, as identified by the Department of Environmental Protection contact person, on the surface of the backfill in a smooth, uniform manner. This item shall include the elimination of all rills and gullies, the construction of sediment control sumps, the removal of sediment control sumps, the grading of spoil and/or fill materials. Surface shall be free of all rock exceeding six (6) inches in diameter and shall be tracked, track

BUYER CB-23	PAGE	REQ. OR PO NO. DEP 14908
SPENDING UNIT WEST VIRGINIA DEPARTMENT OF ENVIRONMENTAL PROTECTION/SPECIAL RECLAMATION		

WV-36a STATE OF WEST VIRGINIA
REV. 5-26-09 PURCHASING CONTINUATION SHEET
VENDOR:

to track. Topsoil presently stockpiled on site shall be preserved and spread on the fill surface. In the absence of stockpiled topsoil, material which can be used as a topsoil substitute shall be identified, segregated, and stockpiled for spreading on the surface. If necessary to manufacture fines, mechanical treatment to pulverize the surface layer shall be required. Regrading and topsoiling shall be conducted prior to and in preparation for the revegetation item.

13.0 TRAPEZOIDAL DITCH - 16'

Provide all materials, excavate and construct ditch or channel as indicated on the attached typical plans, cross-section, specifications, and as discussed at the Pre-Bid Showing. Channels and ditches shall be free draining upon completion of construction. Length of channel may be adjusted to meet on site conditions. (See riprap specifications) R-5 limestone riprap shall be used at a thickness of 1 ½ feet. The top width of the ditch shall be sixteen (16) feet.

14.0 V-DITCH - 4'

Provide all materials, excavate and construct ditch or channel as indicated on the attached typical plans, cross-section, specifications, and as discussed at the Pre-Bid Showing. Channels and ditches shall be free draining upon completion of construction. Length of channel may be adjusted to meet on site conditions. (See riprap specifications) R-5 limestone riprap shall be used at a thickness of 1 ½ feet. The top width of the ditch shall be four (4) feet.

15.0 STRUCTURE / DEBRIS REMOVAL

All existing man-made items particular to the site and not to be utilized in the total reclamation of this site shall be demolished (if necessary) and disposed of in a legal manner. All iron, steel, aluminum, or any other metal, plastic, or any other man made material, including but not limited to I-Beams, Angle Iron, Channel Iron, Corrugated Metal, Flat Metal, Floc Drums, Grease Drums, Pipe or Conduit is to be dismantled, removed and properly disposed of off-site and according to state, local, and federal requirements. These items include a concrete mine entrance, foot foundations on the spoil pad, and various strewn debris.

16.0 SEDIMENT POND ELIMINATION

Existing structure shall be cleaned out, drained, and eliminated as directed at the time of the pre-bid showing. This item will be a one-time payment. Water in pits or sediment structures shall be analyzed and treated before pumping and discharge to receiving waters of the state. Treat to a pH of 6 or to the pH of the receiving stream (whichever is greater).

17.0 POND EXIT CLEANING & MODIFICATION

Structure is presently partially draining through emergency exit spillway. Clean out intended exit culvert inlet area, and reinforce riprap check dam to hold pond at a normal water level 6" below emergency exit spillway.

18.0 REVEGETATION

The actual seeding date, within the work performance period, shall be at the discretion of the contractor, but a permanent vegetative cover must be established. Verification of materials used shall be required for payment. Seed bed preparation, unless otherwise approved, shall be conducted by industrial disks or tracking with heavy equipment with cleat marks across slope and parallel to the final contours. The surface shall be tracked, track to track. Seeding shall commence after seedbed preparation on a loose and uncompacted soil and with the approval of the Department of Environmental Protection. Contractor shall provide equipment as necessary to secure approval of the seedbed. Revegetation activities shall be carried out in a continuous, concurrent, timely and uniform manner. Failure to do this may result in nonpayment for portions of or the entire Revegetation item. Hydroseeding or broadcast seeding with the approved species is acceptable. The application rate may be increased but the ratio is to remain constant, but no additional monetary compensation will be awarded. Areas outside the limits of construction, disturbed by the

BUYER CB-23	PAGE	REQ. OR PO NO. DEP 14908
SPENDING UNIT WEST VIRGINIA DEPARTMENT OF ENVIRONMENTAL PROTECTION/SPECIAL RECLAMATION		

WV-36a STATE OF WEST VIRGINIA
REV. 5-26-09 PURCHASING CONTINUATION SHEET
VENDOR:

contractor, shall be revegetated by the contractor at no expense to DEP. Water utilized for hydroseeding shall be free of injurious or other toxic substances harmful to plant life. The source of water is subject to the approval of the DEP Specialist. It shall be the vendor's responsibility to repeat the procedures under REVEGETATION until a permanent vegetation is established. The acreage quantities in this contract are for bidding purposes only.

A warranty period of one (1) year shall commence upon completion and payment of the revegetation item of the contract. No payment will be made for additional seeding necessary to comply with warranty requirements. The warranty period will be extended for one (1) year from the date of the last augmented seeding done by the contractor. The performance bond and labor and materials bond shall remain in effect throughout the warranty period. The Standards for Evaluating Vegetative Cover as presented in Title 38, CSR2, Section 9 of the West Virginia Surface Mining Reclamation Regulations will apply.

Equipment for the retracking/scarification to eliminate rills and gullies shall be mobilized and utilized to produce slopes consistent with the regrading and topsoiling bid item prior to warranty reseeding. No additional payment will be made by DEP for this warranty work.

Vegetative Enhancement Area (see map, ~1 ac) is included in Revegetation acreage, and shall be treated with lime, fertilizer, mulch, and vegetative species as outlined hereafter.

18.1 AGRICULTURAL LIME

Unless otherwise specified, all lime used shall be registered with the West Virginia Department of Agriculture, have an 85% minimum calcium carbonate equivalent, and meet the fineness classification no larger than that for ground lime. The following fineness classifications or combinations of lime are acceptable:

- Pulverized - 100% passing a U.S. Standard 20 mesh sieve
 - 70% passing a U.S. Standard 100 mesh sieve
- Ground - 90% passing a U.S. Standard 20 mesh sieve
 - 50% passing a U.S. Standard 60 mesh sieve
 - 35% passing a U.S. Standard 100 mesh sieve

Use of blends and low-grade agricultural liming materials shall require prior approval. Lime shall be spread as soon as possible after delivery to site. Lime shall be applied evenly and uniformly distributed over the treated area. Lime shall be thoroughly mixed into the soil material. Lime subjected to adverse conditions before spreading will be deemed unacceptable. Failure to complete this phase shall result in nonpayment of this bid item.

Lime shall be applied at 10 ton/acre.

18.2 FERTILIZER

Fertilizer rates given for REVEGETATION are for 1,000 lbs. of 10-20-20 per acre. These rates are minimum and for bidding purposes.

Fertilizer shall be applied evenly and uniformly distributed over the treated area. Common complete fertilizers which meet the minimum standards are acceptable.

18.3 MULCH

Acceptable mulch for this project is wood fiber, hay, or straw.

Mulch: Wood Fiber @ 1.0 ton/Acre
Hay or straw mulch may be substituted at a rate of 2 tons/Acre

18.4 VEGETATIVE SPECIES

Seeding rate required is for pure live seed (pls) in pounds per acre. The use of annuals or cover crops will not be considered for vegetative success.

VEGETATIVE SPECIES ¹	RATE/ACRE ¹
Orchard Grass	@ 15 lbs/acre
Birdsfoot Trefoil ²	@ 15 lbs/acre

BUYER CB-23	PAGE	REQ. OR PO NO. DEP 14908
SPENDING UNIT WEST VIRGINIA DEPARTMENT OF ENVIRONMENTAL PROTECTION/SPECIAL RECLAMATION		

WV-36a STATE OF WEST VIRGINIA
REV. 5-26-09 PURCHASING CONTINUATION SHEET
VENDOR:

Yellow Sweet Clover @ 5 lbs/acre
Red Clover @ 10 lbs/acre
Ky 31 Fescue @ 15 lbs/acre
Foxtail Millet³ @ 12 lbs/acre
Wheat or Rye⁴ @ 50 lbs/acre

1. Seeding rate suggested is for pure live seed (pls) in pounds per acre.
2. Herbaceous legumes must be treated with the appropriate bacterium before seeding.
3. Spring mix.
4. Fall mix.

BUYER CB-23	PAGE	REQ. OR PO NO. DEP 14908
SPENDING UNIT WEST VIRGINIA DEPARTMENT OF ENVIRONMENTAL PROTECTION/SPECIAL RECLAMATION		

WV-36a STATE OF WEST VIRGINIA
REV. 5-26-09 PURCHASING CONTINUATION SHEET
VENDOR:

BID PREPARATION INFORMATION

HISTORICAL INFORMATION

Prospective bidders may review files at the West Virginia Department of Environmental Protection, Charleston, WV office, or the Regional West Virginia Department of Environmental Protection Office at 105 South Railroad St., Philippi, WV 26416. These files may contain additional information not included in the contract. Documents including, but not limited to, permit applications, permits, inspection reports, environmental documents, permit violation history, geological and geotechnical information, probable hydrologic consequences, maps, modifications, NPDES information and other related data. Copies may be obtained upon request and payment of copying fees.

EXAMINATION OF BID PACKAGE AND SITE OF WORK

The bidder is required to examine, carefully, the bid package (plans, specifications, supplemental specifications, contract forms, etc.) and the site of the work contemplated. The submission of a bid shall be considered prima facie evidence that the bidder has made such examination and has judged for and satisfied themselves as to the character, quantity, and quality of work to be performed and the materials required to be furnished under the contract.

PREBID CONFERENCE

Only the prospective bidders on the sign-in sheet in attendance for the entire Pre-Bid Conference will be eligible to submit bids for consideration of this project. Considerable foot travel over rough terrain and/or inclement weather may be required.

VIDEO

The information given at the pre-bid showing by the project contact person or the assigned person shall be documented on video tape and shall be an integral part of this contract's requirements, but will not supersede the written contract. All information on video tape that is new or provides clarification to the specifications, will be issued in writing by a formal addendum and will become part of the written contract.

INTENT OF CONTRACT

The intent of the contract is for the reclamation/restoration of forfeited mine lands as required by West Virginia Department of Environmental Protection. The contractor is to provide for the construction and completion in every detail of the work described. The Contractor shall furnish all labor, materials, equipment, tools, transportation, and supplies required to complete the work in accordance with the Plans, Specifications, and terms of the Contract.

Should any misunderstanding arise as to the intent or meaning of the Contract, or any discrepancy appear, the decision of the Director of Division of Land Restoration shall be final.

BUYER CB-23	PAGE	REQ. OR PO NO. DEP 14908
SPENDING UNIT WEST VIRGINIA DEPARTMENT OF ENVIRONMENTAL PROTECTION/SPECIAL RECLAMATION		

WV-36a STATE OF WEST VIRGINIA
REV. 5-26-09 PURCHASING CONTINUATION SHEET
VENDOR:

GENERAL PERFORMANCE STANDARDS

INTRODUCTION

The performance standards and non-compliance penalties which govern special reclamation-bond forfeiture projects are in Chapter 22A, Article 3, of the Code of West Virginia and subsequent rules and regulations. The following performance standards are of a general nature and do not represent all the performance standards applicable to a special reclamation-bond forfeiture project. However, some or all of these standards will pertain to each project.

BACKFILLING

1. Unless otherwise noted, the highwall shall be eliminated and the disturbed area graded to the approximate original contour.
2. The material used to backfill and eliminate the highwall shall be sufficiently compacted so as to insure stability of the backfill throughout the warranty period.
3. The land above the highwall shall not be disturbed unless otherwise directed.
4. The best available material to support vegetation, sufficient to establish a permanent vegetative cover and to achieve the approved post mining land use, shall be used.

BLASTING

The performance standards of the blasting regulations must be adhered to.

LIFE OF CONTRACT

The purchase order contract becomes effective on the starting date as specified in the notice to proceed as issued by the Department of Environmental Protection. This contract extends for a period of one (1) year and may be renewed until such "reasonable time" thereafter as is necessary to complete the payment therefore. A responsible Contractor's Agent shall be on the site at all working times who demonstrates a knowledge of mined land reclamation, contract requirements and responds to DEP (owner) inspections.

WORK PERFORMANCE PERIOD

The work performance period is a defined portion of the contract in which all items shall be completed. The work performance period is to be performed within 365 calendar days. Extensions may be granted based upon contractor's performance, weather conditions and site-specific site conditions.

NOTICE TO PROCEED

A notice to proceed shall be issued to the Contractor by the project contact person for the Department of Environmental Protection. Actual construction may only begin after a Notice to Proceed is given and as specified. Such notice shall specify the starting date of the Purchase Order, the work performance period, and the completion date of the work performance period.

BUYER CB-23	PAGE 1	REQ. OR PO NO. DEP 14908
SPENDING UNIT WEST VIRGINIA DEPARTMENT OF ENVIRONMENTAL PROTECTION/SPECIAL RECLAMATION		

WV-36a STATE OF WEST VIRGINIA
REV. 5-26-09 PURCHASING CONTINUATION SHEET
VENDOR:

PRE-CONSTRUCTION CONFERENCE

The Contractor in possession of the awarded purchase order shall schedule a Pre-Construction Conference on the site within ten (10) days after receiving the Notice To Proceed. The Contractor's foreman or the on-the-ground supervisor must be in attendance.

GENERAL SUPERVISION

This contract is under the general supervision of the West Virginia Department of Environmental Protection's contact person for the purpose of contract compliance inspection only. Contractor shall supervise work being conducted at all times. All services rendered by the Engineer/Contact Person consist of professional opinions and recommendations made in accordance with generally accepted engineering practice. Under no circumstances is it the intent of the Engineer/Contact Person to directly control the physical activities of the Contractor or the Contractor's workmen's accomplishment of work on this project.

CONTRACTOR RESPONSIBILITY

The contractor is responsible for compliance with all aspects of this written contract. No changes will be honored without prior approval from the Program Supervisor.

LAWS TO BE OBSERVED

The Contractor shall keep fully informed of all Federal and State laws, all local laws, ordinances, and regulations and all orders and decrees of bodies or tribunals having any jurisdiction or authority, which in any manner affect those engaged or employed on the work, or which in any way affect the conduct of the work. The Contractor shall at all times observe and comply with all such laws, ordinances, regulations, orders and decrees; and shall protect and indemnify the State and its representatives against any claim or liability arising from or based on the violation of any such laws, ordinances, regulations, orders, or decrees, whether by themselves, their subcontractors or their employees.

PERMITS, LICENSES AND TAXES

The Contractor shall procure all permits and licenses, pay all charges, fees, and taxes, and give all notices necessary and incidental to the due and lawful prosecution of the work.

CONCURRENT RECLAMATION

Reclamation of this project shall commence at a definite point as defined and shall progress from that point with total reclamation to include backfilling, grading/regrading, and revegetation. Changes may be granted based upon weather or differing site conditions with prior approval.

WATER QUALITY CONTROL

Shall commence with initial start-up of the project and remain in effect for the extent of the backfilling, regrading and revegetation activity. DEP obtains a storm water permit for each project from the Water Resources Division. (General Water Pollution Control Permit WVO115924) The Contractor is responsible for performing the best management practices. Adequate facilities shall be installed, operated and maintained using the best management practices of the U.S. Environmental Protection Agency's Non-Point Source (NPS) Program for sediment control during the active reclamation. The contractor shall take any and all steps necessary to prevent erosion or silting problems from occurring and to minimize pollution or sedimentation of the stream. If any such problems develop, the contractor shall be responsible to take immediate corrective action. No separate payment for this work will be honored. All impounded waters which require removal during reclamation, shall be pumped with appropriate measures taken to prevent erosion from the discharge. The contractor shall be responsible for treatment of said waters to meet pH standards. The water shall be discharged only when the quality meets a pH equivalent to the pH of the receiving stream but not less than 6.0.

BUYER CB-23	PAGE	REQ. OR PO NO. DEP 14908
SPENDING UNIT WEST VIRGINIA DEPARTMENT OF ENVIRONMENTAL PROTECTION/SPECIAL RECLAMATION		

WV-36a STATE OF WEST VIRGINIA
REV. 5-26-09 PURCHASING CONTINUATION SHEET
VENDOR:

DIFFERING SITE CONDITIONS

During the progress of the work, if subsurface or latent physical conditions are encountered at the site differing materially from those indicated in the contract or if unknown physical conditions of an unusual nature, differing materially from those ordinarily encountered and generally recognized as inherent in the work provided by the contract, are encountered at the site, the party discovering such conditions shall promptly notify the other party in writing of the specific differing conditions before they are disturbed and before the affected work is performed.

Upon written notification, the Engineer/Contact Person will investigate the conditions, and if determined that the conditions materially differ and cause an increase or decrease in the cost or time required for the performance of any work under the contract, an adjustment, excluding loss of anticipated profits, will be made and the contract modified in writing accordingly. The Engineer/Contact Person will notify the Contractor of DEP's determination whether or not an adjustment of the contract is warranted.

No contract adjustment which results in a benefit to the Contractor will be allowed unless the Contractor has provided the required written notice.

No contract adjustment will be allowed under this clause for any effects caused on unchanged work.

HANDLING AND STORAGE OF MATERIALS

Materials which are stored on site, before utilization, shall be stored so as to assure the preservation of their quality and fitness for the work. Stored materials, even though approved before storage, may be inspected again prior to their use in the work. Damaged or deteriorated materials shall be removed and replaced by materials meeting the original specifications.

Aggregate stockpiles shall be made on ground that is denuded of vegetation, hard, and well drained. Removal of aggregate from the stockpile shall be done in a manner which will not result in the inclusion of foreign material into the aggregate. The use of the aggregate will determine if exceptions are permitted.

All materials shall be handled in such a manner as to preserve their quality and fitness for the work.

MAINTENANCE DURING CONSTRUCTION

The contractor shall maintain the work during construction and until the project is accepted. All cost of maintenance work during construction and before the project is accepted shall be included in the unit or lump sum prices on the various pay items.

FINAL INSPECTION

A final inspection meeting by the Department of Environmental Protection's Specialist and the contractor is required for the construction phase and prior to demobilization.

ACREAGE QUANTITIES

The acreage quantities in this contract are for bidding purpose and are set (definite) number for the project area as specified at the pre-bid showing. Only surveyed acreage's through figures the Contractor and/or the State develops will be honored to alter these acreage numbers.

PAYMENT

Invoices must be submitted on prescribed Department of Environmental Protection, Special Reclamation Program forms and include verification. Certified contractor payrolls for operators directly involved in this project and a current workers compensation certificate must accompany each invoice for payment. Verification of wage rates may include employee interviews. Invoices shall be signed in blue ink so that it is easy to verify that document is an original. Vendor should submit with their bid the current remit-to address to be used for payment processing.

MOBILIZATION/DEMobilIZATION shall be invoiced at fifty percent (50%) with the first invoice and the last 50% invoiced after demobilization and acceptance of the road abandonment or final invoice. Demobilization must have written approval.

BUYER CB-23	PAGE	REQ. OR PO NO. DEP 14908
SPENDING UNIT WEST VIRGINIA DEPARTMENT OF ENVIRONMENTAL PROTECTION/SPECIAL RECLAMATION		

WV-36a STATE OF WEST VIRGINIA
REV. 5-26-09 PURCHASING CONTINUATION SHEET
VENDOR:

SPILL CONTAINMENT AREA shall not exceed \$1,000.00 and will be payable in two payments. The first fifty percent (50%) payable with the first invoice and the remainder payable when all fuel tanks, containers and etc., are removed from the site.

Lump sum items shall be percentage payments based on work completed at time of invoice and paid upon acceptance by the Department of Environmental Protection.

Unit items shall be invoiced by specified units completed and accepted by the DEP.

FAILURE TO COMPLETE ON TIME AND LIQUIDATED DAMAGES

Time is an essential element of the Contract and it is important that the work be completed within the time specified. The cost to the Department of the administration of the Contract, including engineering, inspection and supervision, will increase as the time required to complete the work is increased.

The work performance period as specified in the contract's Notice to Proceed shall be complied with or result in liquidated damages. Such damages shall be assessed at an amount of two hundred and fifty dollars (\$250.00) per day for each and every day beyond the work performance period as specified in the Notice to Proceed. The total amount of daily charges will be deducted from any moneys due the Contractor, not as a penalty but as liquidated damages.

REVEGETATION AND WARRANTY

The seeding date shall be at the discretion of the contractor once an approved seedbed has been prepared. In all cases a permanent vegetative cover capable of supporting the post-mining land use must be established. A warranty period of one (1) year shall commence upon completion and payment of the revegetation item of the contract. No payment will be made for additional seeding necessary to comply with warranty requirements. The warranty period will be extended for one (1) year from the date of the last augmented seeding done by the contractor. The performance bond and labor and materials bond shall remain in effect throughout the warranty period. The Standards for Evaluating Vegetative Cover as presented in Title 38, CSR2, Section 9 of the West Virginia Surface Mining Reclamation Regulations will apply.

Equipment for the retracking/scarification to eliminate rills and gullies shall be mobilized and utilized to produce slopes consistent with the regrading and topsoiling bid item prior to warranty reseeding. No additional payment will be made by DEP for this warranty work.

Water utilized for hydroseeding shall be free of injurious or other toxic substances harmful to plant life. The source of water is subject to the approval of the DEP contact person.

CONTRACT NON-COMPLIANCE

If in the opinion of the Department of Environmental Protection the contract is not in compliance with any line item specification, that portion of the project shall cease until a compliance schedule and understanding is demonstrated in writing and accepted by the Director of Division of Land Restoration.

CONTRACT DELETIONS

Any line item, or any portion thereof, may be deleted when determined by the project contact person that such line item, or portion thereof, is deemed unnecessary for the successful reclamation of this project. No claim for loss of anticipated profits will be considered.

BUYER CB-23	PAGE	REQ. OR PO NO. DEP 14908
SPENDING UNIT WEST VIRGINIA DEPARTMENT OF ENVIRONMENTAL PROTECTION/SPECIAL RECLAMATION		

WV-36a STATE OF WEST VIRGINIA
REV. 5-26-09 PURCHASING CONTINUATION SHEET
VENDOR:

CANCELLATION

The performance of work under contract may be terminated by the State in whole, or from time to time in part whenever the State shall determine that such termination is in the best interest of the State. Any such termination shall be effected by delivery to the Contractor of a Notice of Termination specifying the extent to which performance of work under the Contract is terminated and the date upon which such termination becomes effective.

When contracts, or any portion thereof, are terminated before completion of all items of work in the Contract, payment will be made for the actual number of units or items of work completed and accepted at the contract unit price. No claim for loss of anticipated profits will be considered. Reimbursement for organization of the work, when not otherwise included in the Contract, and moving equipment to and from the job will be considered where the volume of work completed and accepted is too small to compensate the Contractor for these expenses under the contract unit prices, the intent being that an equitable settlement will be made with the Contractor.

Termination of the Contract or a portion thereof shall not relieve the Contractor of his responsibilities for the completed work, nor shall it relieve his surety of its obligation for and concerning any just claims arising out of the work performed.

This contract may be cancelled in whole or in part in writing by the Director of Purchasing, without prejudice to any other right or remedy it may have, provided that the contractor is given not less than thirty (30) calendar days written notice, (delivered by certified mail, return receipt requested) of intent to terminate. This contract objective is to comply with the reclamation laws of this state and must be expedient to meet the time requirements for reclamation of revoked surface mine permits.

BUYER CB-23	PAGE	REQ. OR PO NO. DEP 14908
SPENDING UNIT WEST VIRGINIA DEPARTMENT OF ENVIRONMENTAL PROTECTION/SPECIAL RECLAMATION		

WV-36a STATE OF WEST VIRGINIA
REV. 5-26-09 PURCHASING CONTINUATION SHEET
VENDOR:

S

Attn:

A

Re: Notice to Proceed
Permit Name: _____
Permit No. _____
Purchase Order No.: DEP

Dear :

M

The purpose of this letter is to express our appreciation for your work in advance and to recognize a reclamation partnership project. The official starting date for the above mentioned purchase order is . The work performance period must be completed by . The contract life of one year is provided to accomplish all line items and to process all payments within that period.

P

You must schedule a pre-construction conference on site within ten (10) days after receiving this notice to proceed. It is then mandatory that construction begins within ten (10) days of the pre-construction conference and continues diligently until completion of the project. Please contact this office to schedule the pre-construction conference. The foreman, superintendent or on-the-ground supervisor must be in attendance at this conference.

Failure to comply with this notice to proceed will cause termination of the contract and forfeiture of your performance bond.

If you have any questions please feel free to contact this office.

L

Sincerely,

E

BUYER CB-23	PAGE	REQ. OR PO NO. DEP 14908
SPENDING UNIT WEST VIRGINIA DEPARTMENT OF ENVIRONMENTAL PROTECTION/SPECIAL RECLAMATION		

WV-36a STATE OF WEST VIRGINIA
REV. 5-26-09 PURCHASING CONTINUATION SHEET
VENDOR:

General Requirements

Project Construction Sign

Work Required

The work to be performed under this Section consists of providing all labor, material and equipment necessary to install a project sign as indicated on the detail included herein and as specified herein.

Materials

Paint. Paint for the project sign shall be one (1) coat Exterior-Grade Wood Primer- Sealer, and two (2) coats Exterior-Grade Enamel by Glidden or equivalent.

Wood. Sign face shall be 3/4" X 4' X 8' Marine Exterior plywood, and posts and cross braces shall be treated.

Hardware. All hardware shall be manufactured from good, commercial-quality material and be rust resistant such as galvanized coated.

Execution

Project Sign. The signboard shall be cut to the dimensions shown on the details herein. The sign shall be painted with one (1) coat of primer and two (2) coats of white enamel. All exterior cut edges shall be smooth sanded prior to painting. All edges shall be double primed. The letters, border and strips shall be painted as shown on the detail drawing.

The Contractor shall bolt the sign to posts and provide required cross bracing. The posts and sign shall be erected and posts set in gravel base, as shown on the drawings. One (1) sign is required and is to be located at the direction of WVDEP.

Payment. Payment for the work which shall include installation of the project sign shall be incidental to the lump sum bid item for "Mobilization/Demobilization"

Note: No construction work shall commence prior to the project sign being installed.

77 1/4"

17 1/4"

1 1/2"

1 1/8"

15 3/4"

27 3/4"



STATE OF WEST VIRGINIA
DEPARTMENT OF ENVIRONMENTAL PROTECTION

Division of Land Restoration
Office of Special Reclamation

Joe Manchin, III
Governor

Project Cost: \$XXXX,XXX.00
Funding provided by the Special Reclamation Coal Tax paid by WV Coal Mine Companies



Randy C. Huffman,
Cabinet Secretary



Ken Ellison,
Director

Permit Name
Permit Number

Contractor: Joe Smith Contracting

Project Start Date: 01/01/01

CB-23

PAGE

DEP 14908

18"

2 1/4"

73 7/8"

36"

36"

48"

6"

6"



Joe Manchin, III
Governor



Randy C. Huffman,
Cabinet Secretary



Ken Ellison,
Director

STATE OF WEST VIRGINIA
DEPARTMENT OF ENVIRONMENTAL PROTECTION

Division of Land Restoration
Office of Special Reclamation

Project Cost: \$XXXX,XXX.00
Funding provided by the Special Reclamation Coal Tax paid by WV Coal Mine Companies

Permit Name Permit Number	Project Start Date: 01/01/01
------------------------------	------------------------------

Contractor: Joe Smith Contracting

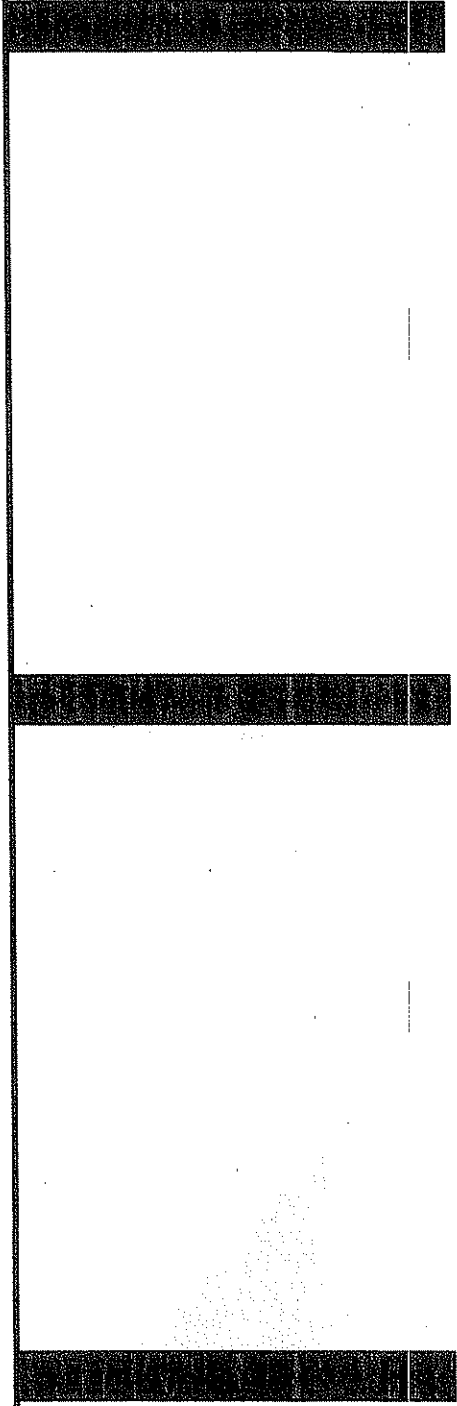

17 1/2" 6"

STATE OF WEST VIRGINIA
DEPARTMENT OF ENVIRONMENTAL PROTECTION

2 1/4"
1 1/2"
2 1/4"
3 3/4"

Division of Land Restoration
Office of Special Reclamation

2 1/4"
1 1/2"
2 1/4"
3 3/4"

Project Cost: \$XXX,XXX.00
 Funding provided by the Special Reclamation Coal Tax paid by WV Coal Mine Companies

1 1/4"
4 7/8"

Permit Name
 Permit Number

2 1/4"
1 1/4"
2 1/4"
4 7/8"
1 1/4"
3 3/4"

Contractor: Joe Smith Contracting
 Project Start Date: 01/01/01



1 1/2" 1 1/2" 1 1/2"

Joe Manchin, III
Governor



9 1/2" 1" 3/4" 1"

Randy C. Huffman,
Cabinet Secretary



8" 3 3/4" 1" 3/4" 1"

Ken Ellison,
Director

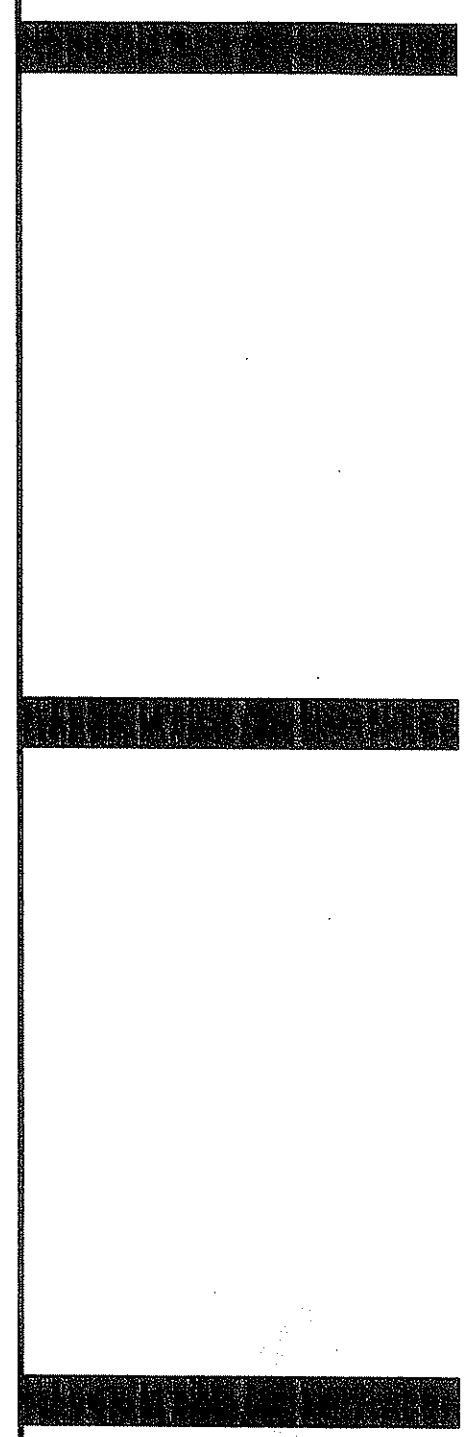

96"



STATE OF WEST VIRGINIA
DEPARTMENT OF ENVIRONMENTAL PROTECTION

Division of Land Restoration
Office of Special Reclamation

Joe Manchin, III
Governor

Project Cost: \$XXX,XXX.00
Funding provided by the Special Reclamation Coal Tax paid by WV Coal Mine Companies



Randy C. Huffman,
Cabinet Secretary



Ken Ellison,
Director

Permit Name
Permit Number
Contractor: Joe Smith Contracting
Project Start Date: 01/01/01

81 3/8"

7 7/8"

9 3/8"

5 1/4"

48"

- NOTES:**
- 1.) SIGN BOARD TO BE 3/4" x 4' x 8' MARINE PLYWOOD.
 - 2.) SIGN BOARD COLOR IS WHITE AND LETTER COLORS ARE DARK GREEN.
 - 3.) TREATED 2" x 4" CROSS BRACE LET INTO POSTS.
 - 4.) MOUNT SIGN TO POSTS USING 3/8" x 5" GALVANIZED CARRIAGE BOLTS.
 - 5.) USE 4" x 4" x 12' TREATED POSTS.
 - 6.) LOCATION DETERMINED BY WVDOT.

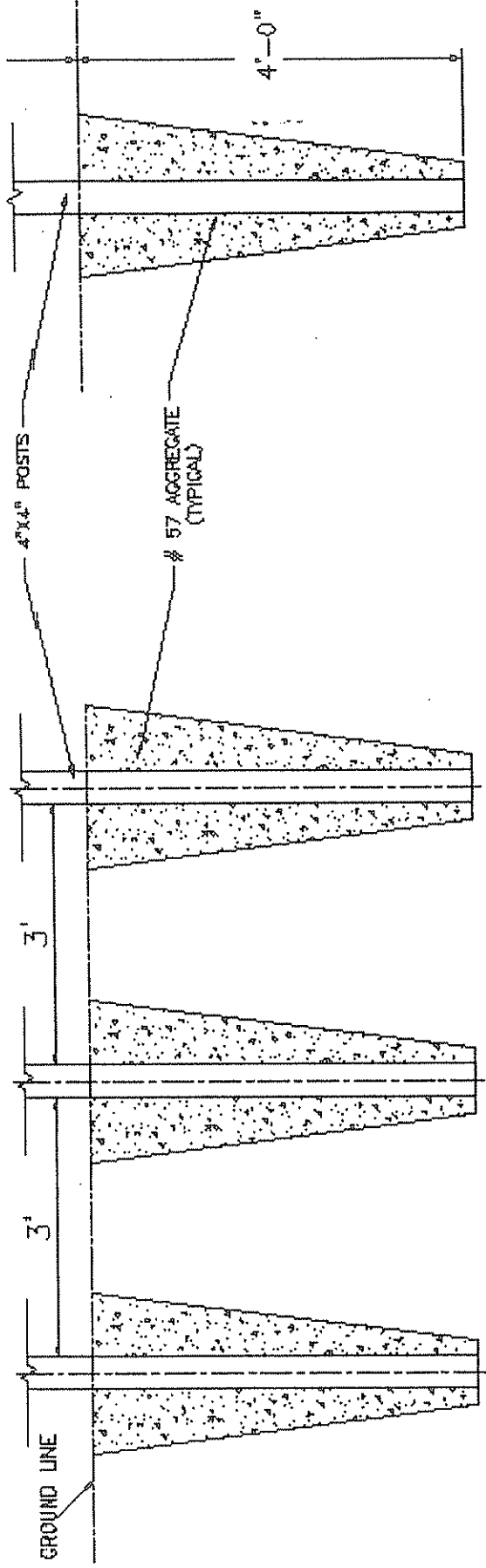
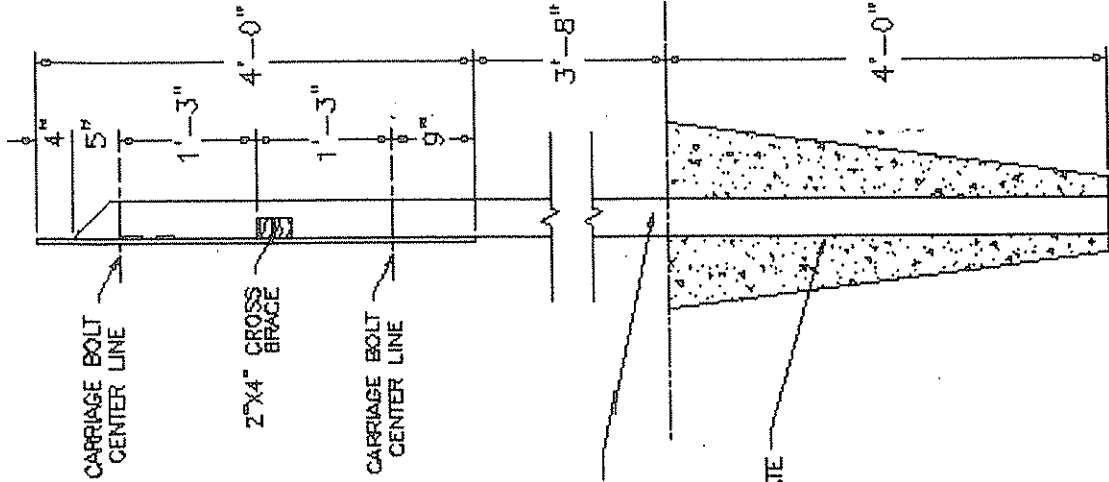

PROJECT SIGN
NOT TO SCALE

SPILL CONTAINMENT

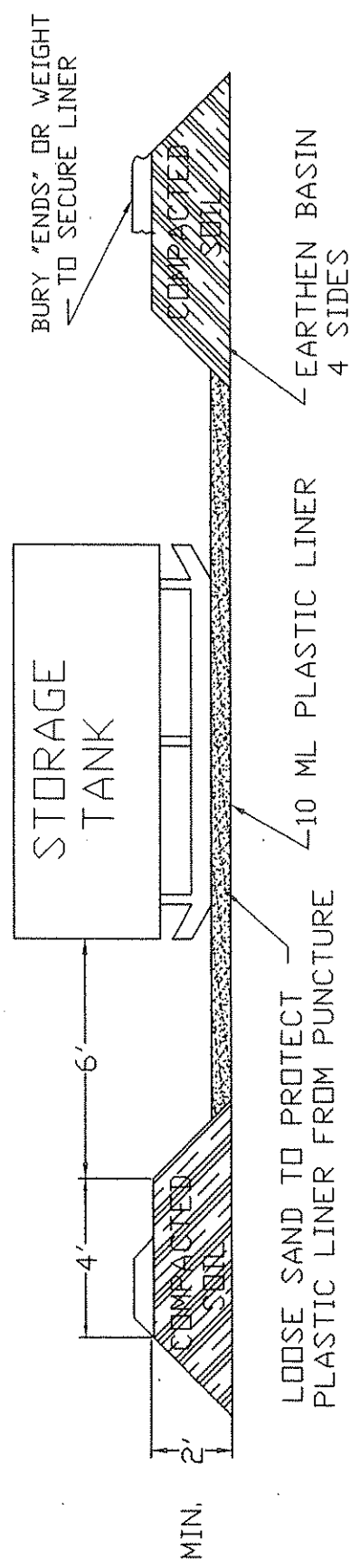

SELECTED HEIGHT OF EARTHEN BERM IS TO BE A TWO (2') FOOT MINIMUM OR ONE HUNDRED TEN PERCENT (110%) OF THE CAPACITY OF THE TANK(S) TOTAL VOLUME WITHIN THE BERM. A SIX (6") INCH FREEBOARD MUST BE INCLUDED.

NOTE: A TWO INCH (2") WATER REMOVAL DRAIN SHALL BE LOCATED AT THE LOWEST POINT IN THE BOTTOM OF THE CONTAINMENT VOLUME. IT SHALL CONNECT TO A NORMALLY CLOSED VALVE OUTSIDE THE DIKE. THE VALVE SHALL BE MANUALLY OPERATED AND PROTECTED FROM UNAUTHORIZED OPERATION. RAINWATER CONTAINED WITHIN THIS DIKE SHALL BE EXAMINED PRIOR TO RELEASE TO ENSURE THAT HARMFUL QUANTITIES OF FUELS AND LUBRICANTS ARE NOT DISCHARGED. ALTERNATE METHODS OF WATER REMOVAL WILL BE CONSIDERED FOR APPROVAL.

TANKS WITH SECONDARY CONTAINMENT MAY BE USED AS AN ALTERNATIVE.

BUYER CB-23	PAGE	REQ. or P.D. No. DEP 14908
TYGART VALLEY SITE PLAN		

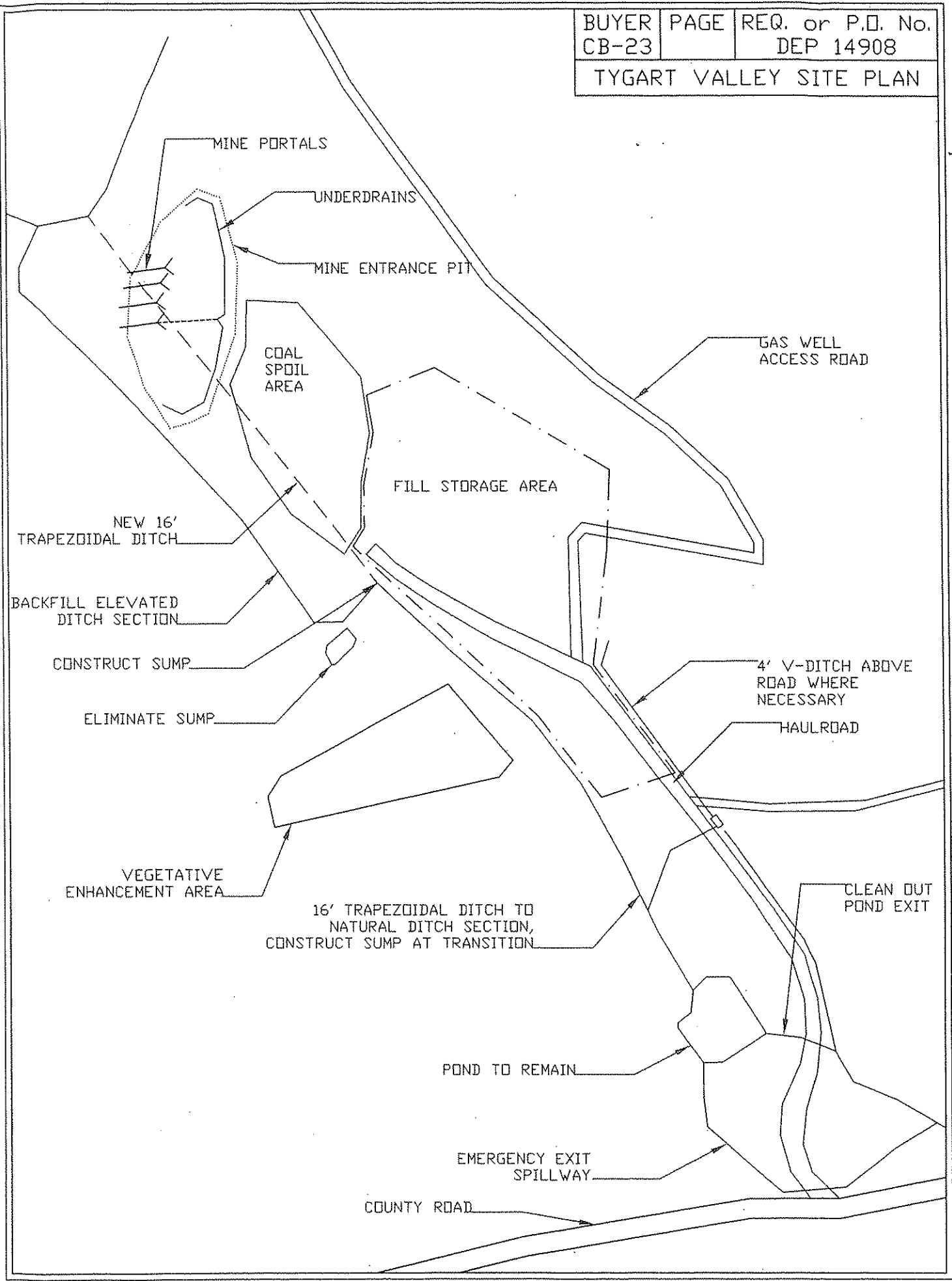

TRAPEZOIDAL - DITCH

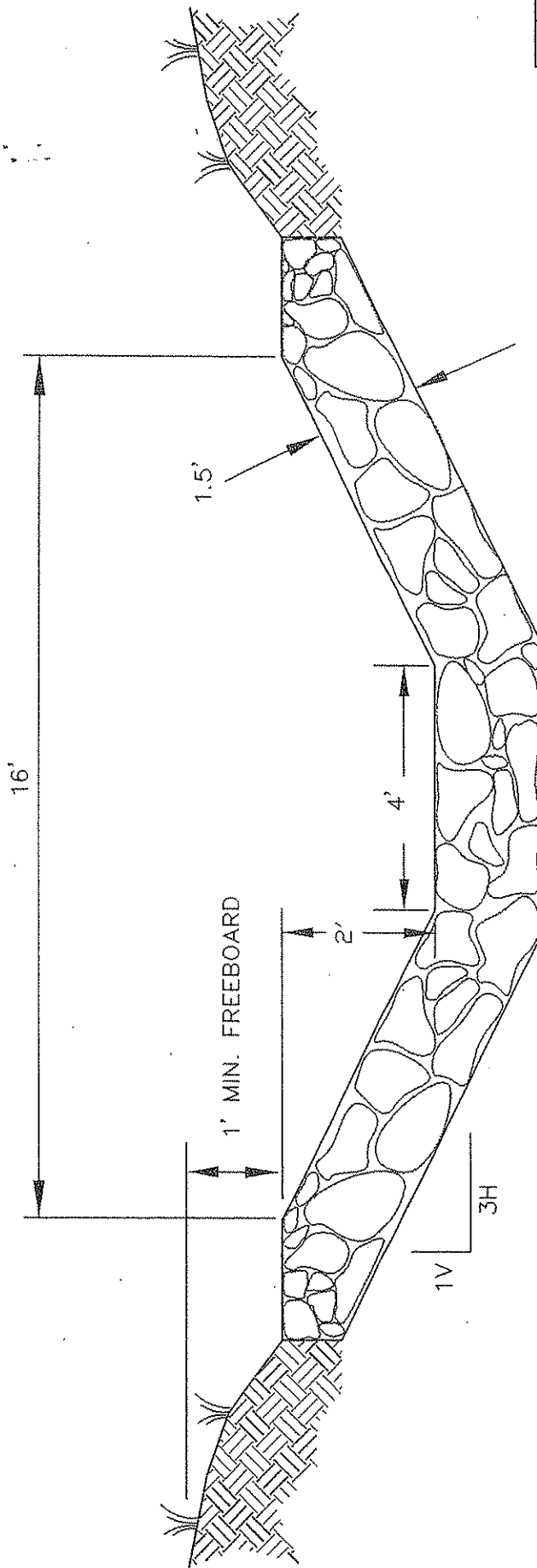

BUYER
CB-23

PAGE

REQ. or P.O. No.
DEP 14908

TRAPEZOIDAL - DITCH

NOT TO SCALE

PAYMENT SHALL BE FOR ACTUAL LENGTH OF DITCH CONSTRUCTED.

R-5 LIMESTONE RIPRAP (STANDARD) UNLESS OTHERWISE NOTED, RIPRAP SHALL BE DURABLE ROCK PLACED IN A 1.5 FOOT BLANKET. TWENTY-FIVE (25%) OF THE ROCK WILL BE OF 18 INCHES OR LARGER, THE REMAINING SEVENTY-FIVE (75%) SHALL BE WELL GRADED MATERIAL (MINIMUM 3 INCHES TO MAXIMUM 15 INCHES) OF SUFFICIENT ROCK SMALL ENOUGH TO FILL THE VOIDS BETWEEN THE LARGER ROCK. SHALE SHALL NOT BE USED FOR RIPRAP. IF RIPRAP STABILITY IS QUESTIONABLE, DURABILITY SHALL BE DETERMINED BY THE SODIUM SULPHATE TEST ASTM C 88/AASHTO T 104-77.

BUYER CB-23	PAGE	REQ. or P.O. No. DEP 14908
4' V - DITCH		

4' V - DITCH

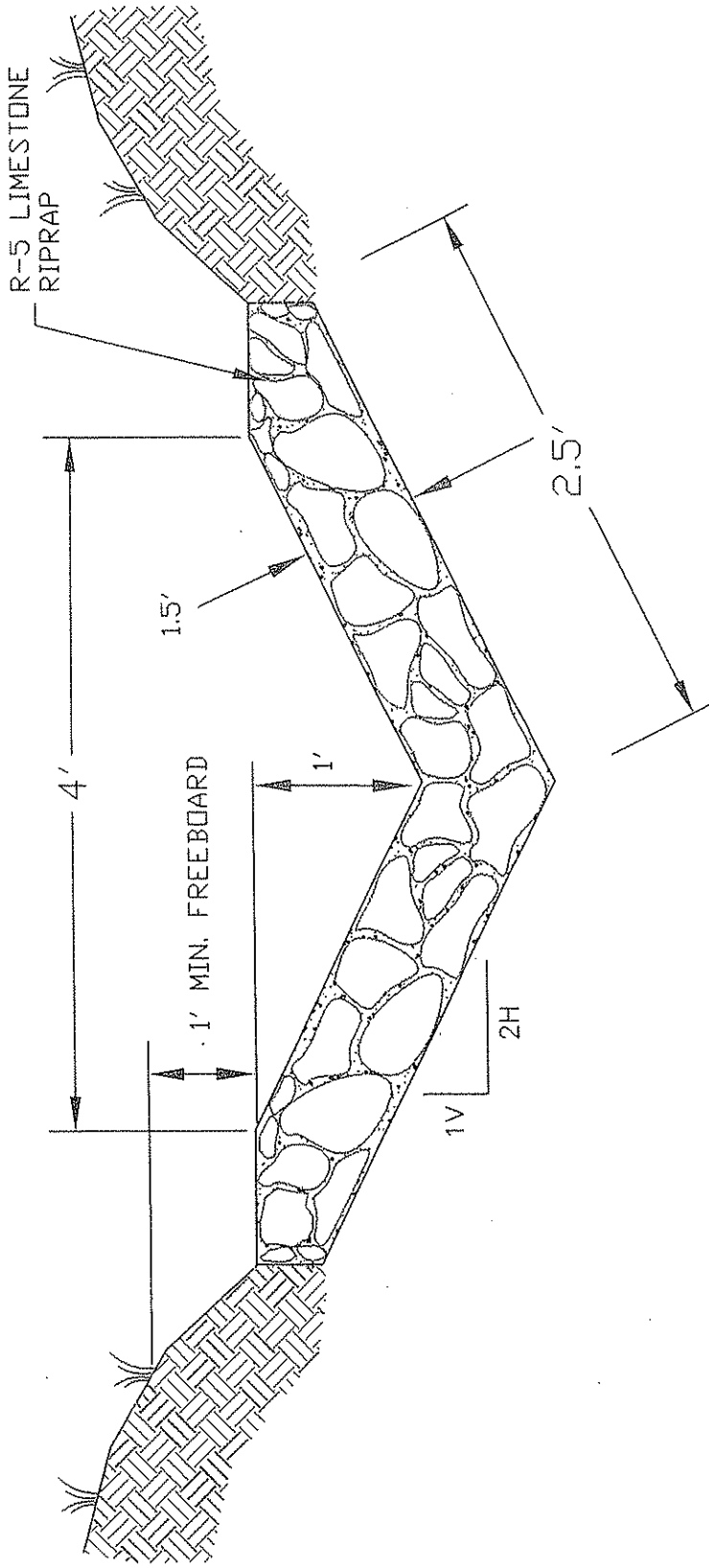

NOT TO SCALE

PAYMENT SHALL BE FOR ACTUAL LENGTH OF DITCH CONSTRUCTED.

R-5 LIMESTONE RIPRAP (STANDARD) UNLESS OTHERWISE NOTED, RIPRAP SHALL BE DURABLE ROCK PLACED IN A 1.5 FOOT BLANKET. TWENTY-FIVE (25%) OF THE ROCK WILL BE OF 18 INCHES OR LARGER, THE REMAINING SEVENTY-FIVE (75%) SHALL BE WELL GRADED MATERIAL (MINIMUM 3 INCHES TO MAXIMUM 15 INCHES) OF SUFFICIENT ROCK SMALL ENOUGH TO FILL THE VOIDS BETWEEN THE LARGER ROCK. SHALE SHALL NOT BE USED FOR RIPRAP. IF RIPRAP STABILITY IS QUESTIONABLE, DURABILITY SHALL BE DETERMINED BY THE SODIUM SULPHATE TEST ASTM C 88/AASHTO T 104-77.

SEDIMENT CONTROL SUMP

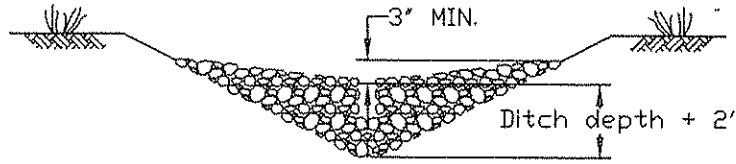

SECTION A-A

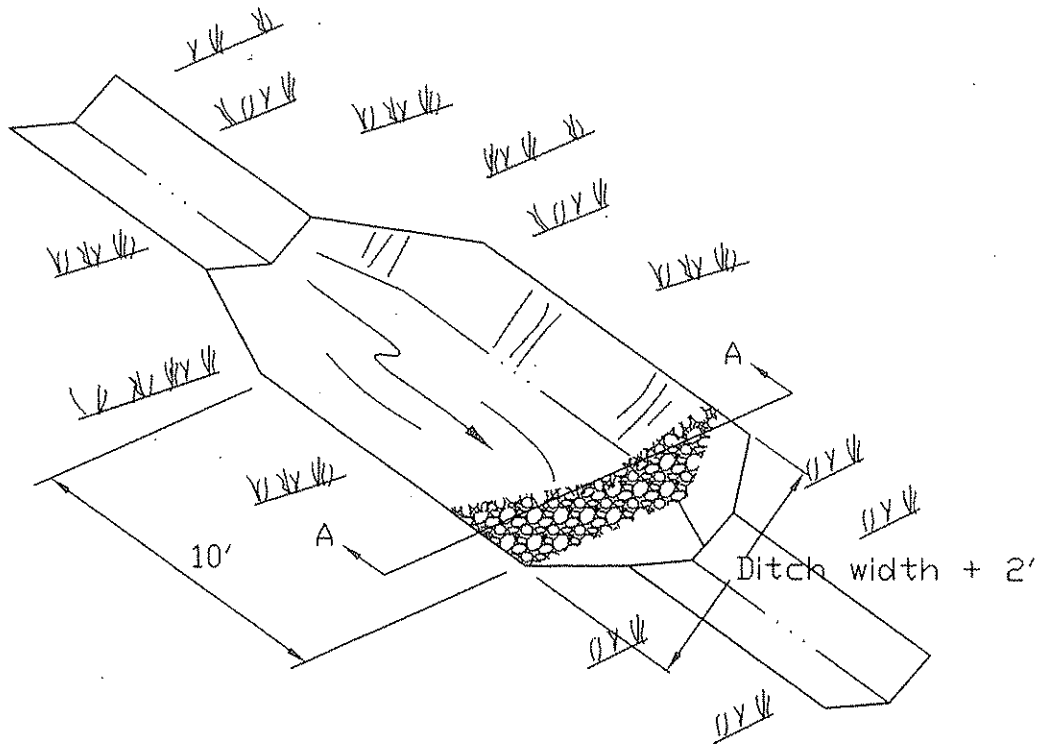

NOTE:

THE SUMP MUST BE CLEANED WHEN 60% FULL.
ROCK OR HAYBALES SHALL BE PLACED AT SUMP OUTLET.
THE MINIMUM DITCH DEPTH IS 1.0', AND THE MINIMUM SUMP DEPTH IS 4.0'.

BUYER CB-23	PAGE	REQ. or P.O. No. DEP 14908
ACCESS ROAD UPGRADE		

ACCESS ROAD UPGRADE

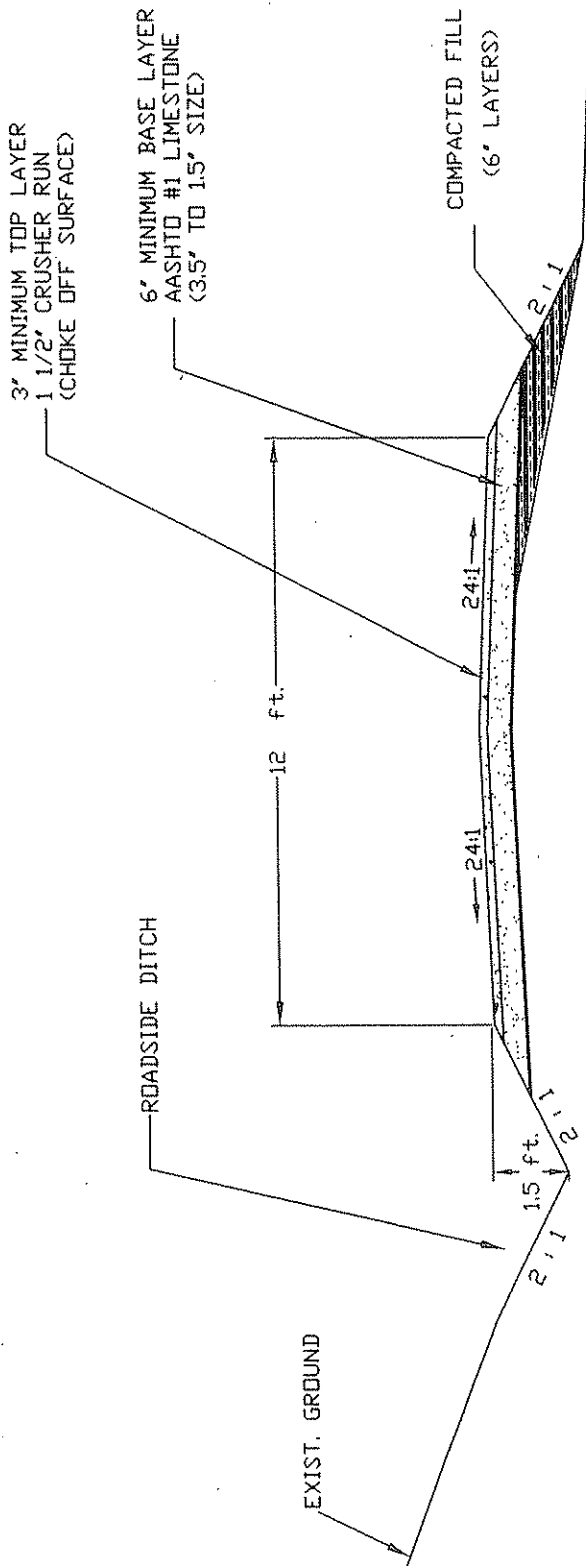

TYPICAL SECTION

NOTES: THE EXISTING ROAD SHALL BE REGRADED, SHAPED, AND ROCKED IN CERTAIN LOCATIONS AS NECESSARY TO MEET THESE SPECIFICATIONS.
 THE 6" BASE LAYER OF STONE SHALL BE USED AS NEEDED, AND SHALL BE PAID BY THE TON UNDER A SEPARATE BID ITEM.

SEEP COLLECTOR

NOT TO SCALE

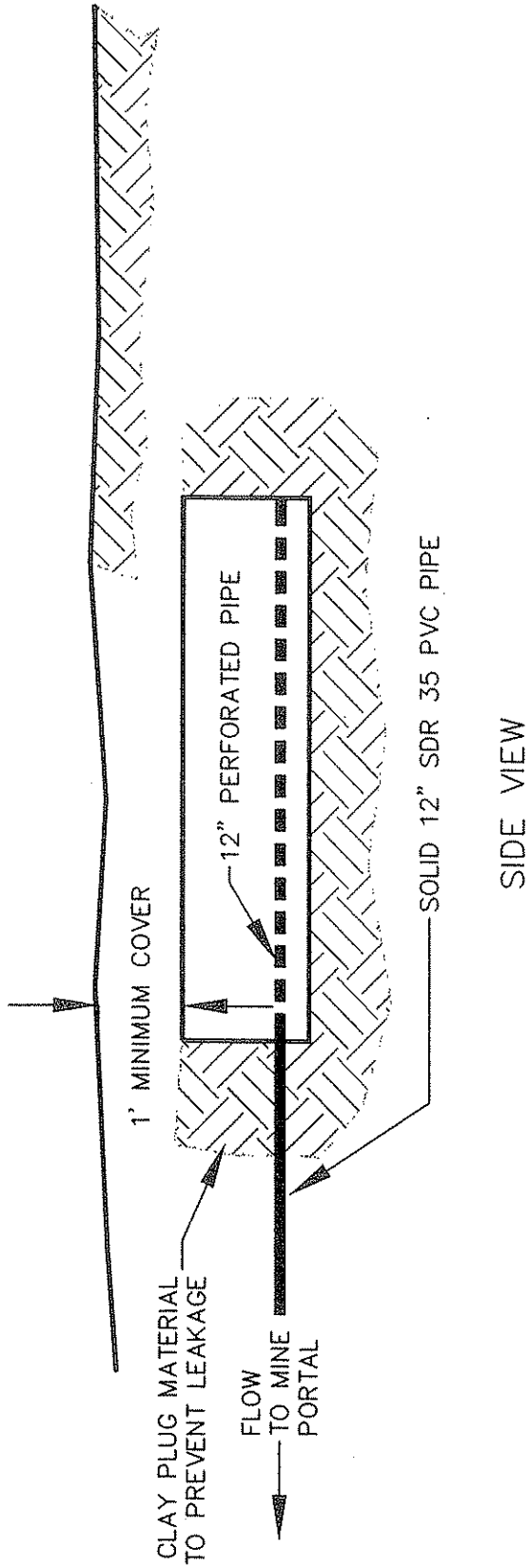

WRAP WITH FILTER FABRIC (NONWOVEN) TYPAR 3401 or EQUIVALENT

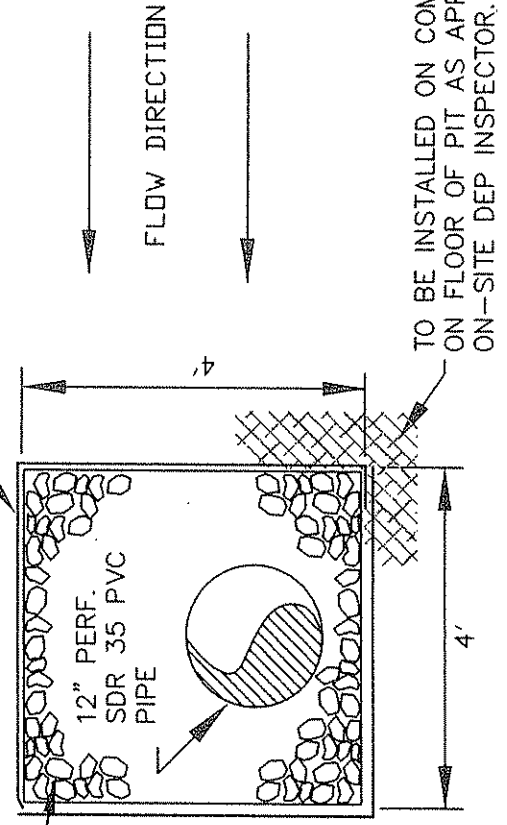

BUYER CB-23	PAGE	REQ. or P.O. No. DEP 14908
----------------	------	-------------------------------

STRAW/HAY BALE DIKE

2 REBAR, STEEL PICKETS, OR
2"x2" STAKERS PER BALE
DRIVEN 1' MIN. INTO GROUND

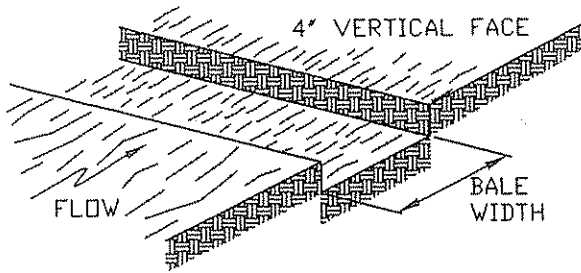

1. EXCAVATE THE TRENCH.

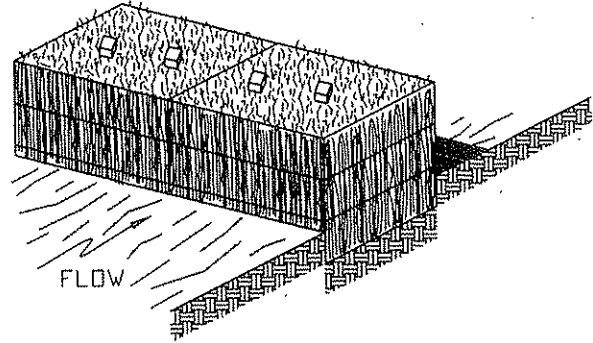

2. PLACE AND STAKE THE BALES.

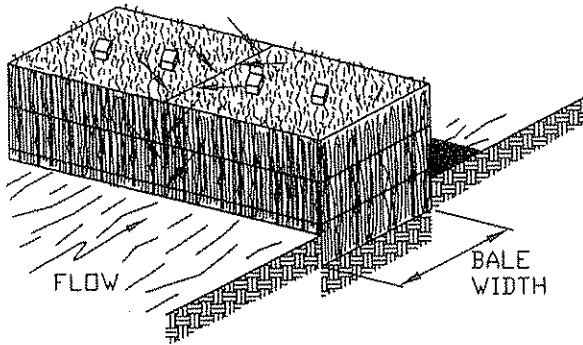

3. WEDGE LOOSE STRAW BETWEEN BALES.

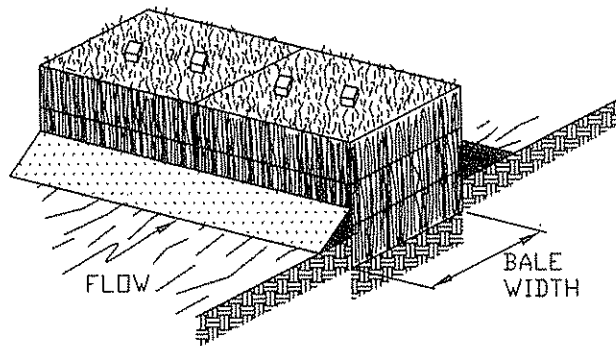

4. BACKFILL AND COMPACT THE EXCAVATED SOIL.

HAY OR STRAW BALE INSTALLATION SEQUENCE

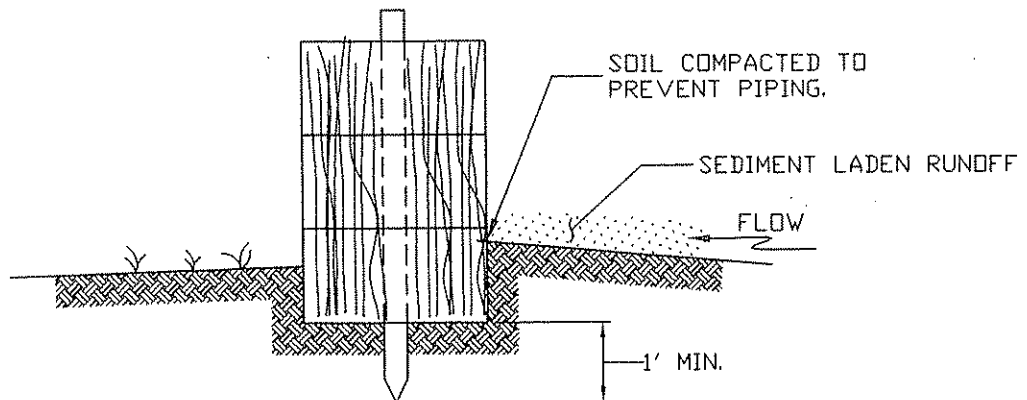

PROPERLY INSTALLED BALE

BUYER CB-23	PAGE	REQ. or P.O. No. DEP 14908
SILT FENCE INSTALLATION		

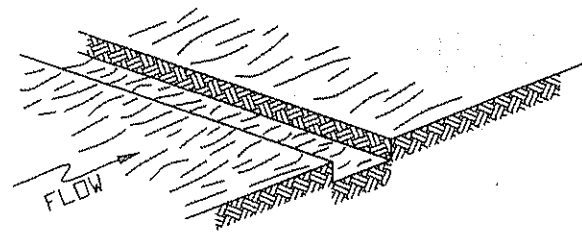

1. EXCAVATE 6" X 6" TRENCH

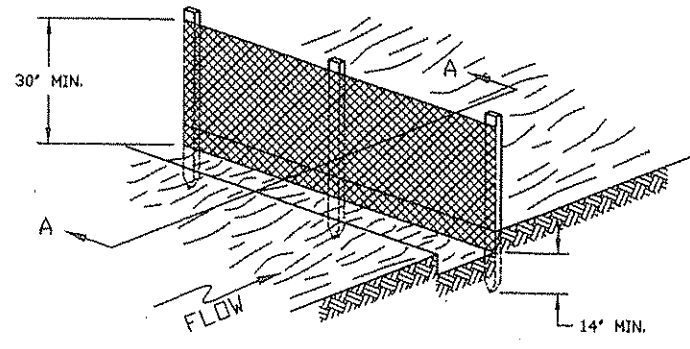

2. PLACE FENCE AT BACK EDGE OF TRENCH (FABRIC FACING DIRECTION OF FLOW)

3. DRIVE POST UNTIL FABRIC REACHES BOTTOM OF TRENCH

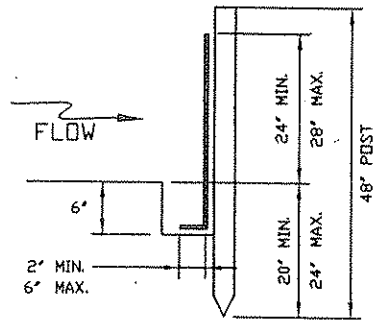

SECTION A-A

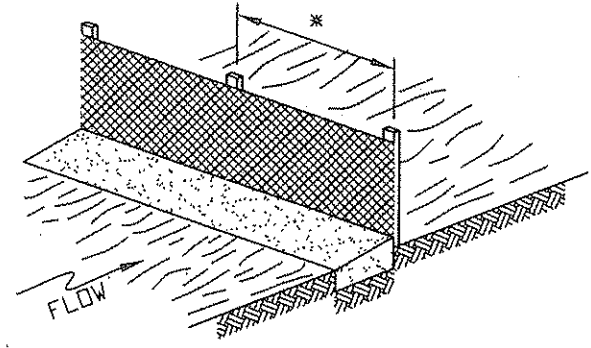

* SEE SPECIFICATIONS FOR REQUIRED POST SPACING.

4. FILL TRENCH WITH EMBANKMENT & TAMP

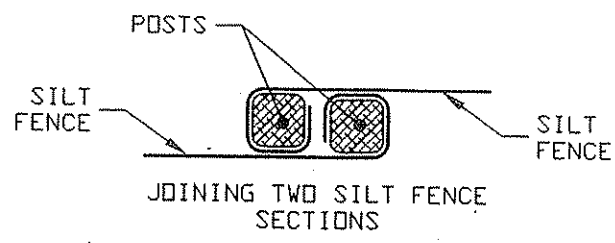

NOTE: WHEN MORE THAN ONE ROLL OF SILT FENCE IS USED, THE FENCE AT THE JUNCTION MUST BE PLACED SO THAT THE LAST POST OF THE FIRST RUN & THE FIRST POST OF THE SECOND RUN OVERLAP & ARE TIED TOGETHER.



State of West Virginia
 Department of Administration
 Purchasing Division
 2019 Washington Street East
 Post Office Box 50130
 Charleston, WV 25305-0130

Request for Quotation

RFQ NUMBER
DEP14908

PAGE
1

ADDRESS CORRESPONDENCE TO ATTENTION OF
**CHUCK BOWMAN
 304-558-2157**

PROPERTY

RFQ COPY
 TYPE NAME/ADDRESS HERE
**RBS Inc
 PO Box 490
 White Sulphur Springs WV
 24986**

SHIP TO

**ENVIRONMENTAL PROTECTION
 DEPT. OF
 OFFICE OF SPECIAL RECLAMATION
 105 S. RAILROAD STREET
 PHILIPPI, WV
 26416-9998 304-457-3219**

DATE PRINTED	TERMS OF SALE	SHIP VIA	FOB	FREIGHT TERMS
04/07/2010				

BID OPENING DATE: **04/20/2010** BID OPENING TIME **01:30PM**

LINE	QUANTITY	UQP	CAT NO	ITEM NUMBER	UNIT PRICE	AMOUNT
<p>*****ADDENDUM NO. 1*****</p> <p>ADDENDUM ISSUED FOR THE TYGART VALLEY MINING CO. PROJECT TO DISTRIBUTE THE PRE-BID SIGN-IN SHEETS AND THE Q/A RESULTING FROM THE 03/23/10 MANDATORY PRE-BID MEETING.</p> <p>BID OPENING DATE AND TIME REMAIN UNCHANGED AS 04/20/10 AT 1:30 PM.</p> <p>*****NO OTHER CHANGES*****</p>						
0001	1	JB		962-73		
RECLAMATION: RESTORATION OF LAND						
***** THIS IS THE END OF RFQ DEP14908 ***** TOTAL:						382,140⁰⁰

SEE REVERSE SIDE FOR TERMS AND CONDITIONS

SIGNATURE <i>[Signature]</i>	TELEPHONE (304) 645-2277	DATE 16 April 2010
TITLE VP	FEIN 55-0477166	ADDRESS CHANGES TO BE NOTED ABOVE

WHEN RESPONDING TO RFQ, INSERT NAME AND ADDRESS IN SPACE ABOVE LABELED 'VENDOR'

GENERAL TERMS & CONDITIONS
REQUEST FOR QUOTATION (RFQ) AND REQUEST FOR PROPOSAL (RFP)

1. Awards will be made in the best interest of the State of West Virginia.
2. The State may accept or reject in part, or in whole, any bid.
3. Prior to any award, the apparent successful vendor must be properly registered with the Purchasing Division and have paid the required \$125 fee.
4. All services performed or goods delivered under State Purchase Order/Contracts are to be continued for the term of the Purchase Order/Contracts, contingent upon funds being appropriated by the Legislature or otherwise being made available. In the event funds are not appropriated or otherwise available for these services or goods this Purchase Order/Contract becomes void and of no effect after June 30.
5. Payment may only be made after the delivery and acceptance of goods or services.
6. Interest may be paid for late payment in accordance with the *West Virginia Code*.
7. Vendor preference will be granted upon written request in accordance with the *West Virginia Code*.
8. The State of West Virginia is exempt from federal and state taxes and will not pay or reimburse such taxes.
9. The Director of Purchasing may cancel any Purchase Order/Contract upon 30 days written notice to the seller.
10. The laws of the State of West Virginia and the *Legislative Rules* of the Purchasing Division shall govern the purchasing process.
11. Any reference to automatic renewal is hereby deleted. The Contract may be renewed only upon mutual written agreement of the parties.
12. **BANKRUPTCY:** In the event the vendor/contractor files for bankruptcy protection, the State may deem this contract null and void, and terminate such contract without further order.
13. **HIPAA BUSINESS ASSOCIATE ADDENDUM:** The West Virginia State Government HIPAA Business Associate Addendum (BAA), approved by the Attorney General, is available online at www.state.wv.us/admin/purchase/vrc/hipaa.htm and is hereby made part of the agreement. Provided that the Agency meets the definition of a Cover Entity (45 CFR §160.103) and will be disclosing Protected Health Information (45 CFR §160.103) to the vendor.
14. **CONFIDENTIALITY:** The vendor agrees that he or she will not disclose to anyone, directly or indirectly, any such personally identifiable information or other confidential information gained from the agency, unless the individual who is the subject of the information consents to the disclosure in writing or the disclosure is made pursuant to the agency's policies, procedures, and rules. Vendor further agrees to comply with the Confidentiality Policies and Information Security Accountability Requirements, set forth in <http://www.state.wv.us/admin/purchase/privacy/noticeConfidentiality.pdf>.
15. **LICENSING:** Vendors must be licensed and in good standing in accordance with any and all state and local laws and requirements by any state or local agency of West Virginia, including, but not limited to, the West Virginia Secretary of State's Office, the West Virginia Tax Department, and the West Virginia Insurance Commission. The vendor must provide all necessary releases to obtain information to enable the director or spending unit to verify that the vendor is licensed and in good standing with the above entities.
16. **ANTITRUST:** In submitting a bid to any agency for the State of West Virginia, the bidder offers and agrees that if the bid is accepted the bidder will convey, sell, assign or transfer to the State of West Virginia all rights, title and interest in and to all causes of action it may now or hereafter acquire under the antitrust laws of the United States and the State of West Virginia for price fixing and/or unreasonable restraints of trade relating to the particular commodities or services purchased or acquired by the State of West Virginia. Such assignment shall be made and become effective at the time the purchasing agency tenders the initial payment to the bidder.

I certify that this bid is made without prior understanding, agreement, or connection with any corporation, firm, limited liability company, partnership, or person or entity submitting a bid for the same material, supplies, equipment or services and is in all respects fair and without collusion or fraud. I further certify that I am authorized to sign the certification on behalf of the bidder or this bid.

INSTRUCTIONS TO BIDDERS

1. Use the quotation forms provided by the Purchasing Division. Complete all sections of the quotation form.
2. Items offered must be in compliance with the specifications. Any deviation from the specifications must be clearly indicated by the bidder. Alternates offered by the bidder as **EQUAL** to the specifications must be clearly defined. A bidder offering an alternate should attach complete specifications and literature to the bid. The Purchasing Division may waive minor deviations to specifications.
3. Unit prices shall prevail in case of discrepancy. All quotations are considered F.O.B. destination unless alternate shipping terms are clearly identified in the quotation.
4. All quotations must be delivered by the bidder to the office listed below prior to the date and time of the bid opening. Failure of the bidder to deliver the quotations on time will result in bid disqualifications: Department of Administration, Purchasing Division, 2019 Washington Street East, P.O. Box 50130, Charleston, WV 25305-0130
5. Communication during the solicitation, bid, evaluation or award periods, except through the Purchasing Division, is strictly prohibited (W.Va. C.S.R. §148-1-6.6).

**Addendum #1 - Questions During Pre-Bid Conference
For DEP 14908
Tygart Valley Mining Company, Inc.
Permit # U-2002-95**

The following questions were identified at the Pre Bid Conference (PBC). The answers provided herein take precedence over verbal answers at the PBC should there be any conflicts between the two.

- 1.) Q. Are the power lines staying in?
A. No, the power lines shall be removed to the last pole by the road, and can be salvaged. The landowner would like to keep the poles, they shall be pulled and stored on site. This item will be paid with the structure and debris removal line item.
- 2.) Q. Is the power disconnected?
A. Per the landowner, the power should be off. That will be for the contractor to verify with the power company.
- 3.) Q. Does the 4' ditch start here (where the gas line crosses the road) and go up?
A. The 4' ditch goes down to where the pond exit crosses the road, and follows the uphill side of the access road all the way up to where it ties in with the gas well road.
- 4.) Q. Is that pond the pond that needs to be cleaned (referring to lower pond)?
A. The exit of the lower pond needs to be cleaned out, not the entire pond.
- 5.) Q. Your 16' channel says it ties to the natural ditch, do you have a place where that is?
A. They will tie in with a sump where excavation of spoil material under the roadbed ends, essentially anywhere there is disturbance.
- 6.) Q. How far back here are we going, where is the regrade going to start (on access road hillside)?
A. The spoil pile material is essentially where most of your material is for backfilling the pit; the regrading will go as far as you need to go to bring this road down to get the pit and highwalls back to a 2 to 1 grade.
- 7.) Q. [At the pit] Do you want the material down there to be removed?
A. Yes, that will have to be pulled out and mixed with lime, and set on a pad.
- 8.) Q. So you're going to drain the water back into the mine?
A. Yes, there are drains on the other side of the hill at the down dip end of the mine. The surface drainage shall be directed via the 16' trapezoidal ditch down to the pond. The underdrain is basically a precaution for water that seeps down into the backfill.
- 9.) Q. You're going to lay the underdrain just on the floor (of the pit)?
A. There's portions you'll have to excavate, and you'll have to pull out that black material, and you'll have to create a bench for it to drain towards a common point to go into the portal.

DEP 14908

Tygart Valley Mining Company, Inc.

Permit # U-2002-95

- 10.) Q. Are we taking out all the mess down there (in the pit)?
A. Not all of it, just the black material which shall be suspended off the floor in the backfill. [CLARIFICATION: Portal structure and any other debris shall also be removed from the pit, as well as any organic material (cattails, etc.) which should not be in the backfill.]
- 11.) Q. Does the mine get stone back in it like a regular seal, or just run the pipe back into it?
A. The pipe will need to run at least 40' into the mine, with fill pushed in around it just like a dry seal.
- 12.) Q. Does this trapezoidal ditch stay along the upper side?
A. No, it will run right down the center of the hollow and connect up in the middle of where the natural drain is.
- 13.) Q. That's going to dump into our V-ditch?
A. No, that will dump into the natural drain that's feeding the pond. Not the V-ditch on the uphill side of the road.
- 14.) Q. You're wanting to get (backfill) to the top of those highwalls?
A. Yes, to the topmost disturbance you can see, including regrading the current diversion ditch.
- 15.) Q. So the (trapezoidal) ditch is one constant grade from the start down to where it ties in?
A. Yes, it shall be a constant grade, with a sump where the 16' trapezoidal ditch ties into the existing natural drain.
- 16.) Q. Do you believe there's sufficient material out there (to backfill the pit and regrade the highwalls)?
A. Yes, we believe that between the spoil pile and where the road is benched up there is sufficient material.
- 17.) Q. Can you go above the highwall any for material?
A. No, there is a gas well, gas line, and road up there that can't be disturbed, plus we don't believe you'll need any more material than is in the spoil pile and road base. We will not be disturbing above the highwall.
- 18.) Q. Where is the soil cover?
A. We'll have to go with best available material for topsoil. We believe there's some in the spoil pile, as well as potentially just underneath this black material on the pad.
- 19.) Q. There is no designated topsoil pile here?
A. No.

DEP 14908

Tygart Valley Mining Company, Inc.

Permit # U-2002-95

- 20.) Q. For these two big piles of wood up here?
A. The big piles of wood, as well as any clearing and grubbing, can be burned. If required, burn permits shall be acquired beforehand. That will be paid under the structure and debris removal line item.
- 21.) Q. Your big ditch goes all the way to the pond, right?
A. No, that should only go as far as we need to tie into this natural stream channel. We'll take it as far as we need to disturb material under the road for backfilling the pit.
- 22.) Q. How big is the sump?
A. There's a specification for the sump in the requisition. It's just a sediment sump, 10' long and 2 feet wider (and deeper) than the ditch itself.
- 23.) Q. So are you guys saying you want a continuous slope from the natural drain to the woodline, or can it be up on a 2 to 1 slope?
A. We want a 2 to 1 slope at the steepest, it may be less than that in places.
- 24.) Q. And we're regrading out to where the grass is there now?
A. That will depend on how far down we need to go to get material to bring back into the pit. We don't want to go much past where it's already revegetated, that's been reclaimed.
- 25.) Q. What are you going to do about the ditch (gas well road)?
A. That's actually the gas well road. We want to leave one road for gas well access, and regrade and revegetate everything else.
- 26.) Q. Is there anything in the drawings for the ditch to cross the gas well access road?
A. No, the V-ditch will stay on the uphill side of the road all the way up to where we tie in to the existing gas well road, and down to where the culvert and gas line currently cross the road.
- 27.) Q. Do we leave the culvert that crosses the road?
A. Yes, that's where the gas line crosses the road, and some riprap will be used at the outlet of that culvert as it flows down to the natural drain. V-ditch will also continue along the uphill side of the road below that culvert.
- 28.) Q. Will the tank stay on the end of the pipe (culvert)?
A. Yes, that acts as a filter for the culvert, and will stay there as is.
- 29.) Q. How much of this power line has to come out?
A. It can come out to the last power pole by the road.
- 30.) Q. It can or it has to?
A. It has to. It shall come out.
- 31.) Q. Will this gate remain open if we need to come back?
A. Yes, the gate will not be locked. It will be closed but not locked.

MANDATORY PRE-BID SIGN-IN ATTENDANCE SHEET

5

RFQ # : DEP14908 Bid Date: 04/20/2010
 Project: Tygart Valley Mining Co. Pre-Bid Date: 03/23/10
U-2002-95

Name : DAVID H. BOWMAN
 Company: Green Mountain Co
 Address: 511 50th STREET
Chas WJ
25304
 Phone #: 304 925 0253
 Fax #: 925 9230
 Email : Jody.Mayer@apl.com

Name : Matt Adams
 Company: Kelli Corp
 Address: 3075 Point Marion Rd
Mohrstown WV 26505
 Phone#: 304 292 8102
 Fax #: 304 292 8608
 Email : adams.mika@comcast.net

Name : Mick Jones
 Company: Beront Const.
 Address: Box 10 Proins W
25164
 Phone #: 304 548 7004
 Fax #: 548 7133
 Email : berontconst@yahoo.com

Name : GEORGE FRESHOUR
 Company: EAGLE EXCAVATION INC
 Address: P.O. BOX 218
KENNA WV
25248
 Phone#: (304) 372-4378
 Fax #: (304) 372-4378
 Email : GEORGE

Name : Junior Stanley
 Company: Stanley Industries, Inc
 Address: 7 Maple Lake
Bridgport WV 26330
 Phone #: 304-842-8560
 Fax #: 304-842-8609
 Email : jstanley@ma.rr.com

Name : Robert L. Barnes
 Company: BARNES EXC. INC.
 Address: P.O. BOX 13384
Sissonville
WV. 25360
 Phone#: 304-984-1725
 Fax #: 304-984-0074
 Email : BARNES EXC. @ Apl.com

Name : Steve Juraska
 Company: Polino Contracting, INC.
 Address: Po Box 230
Elkins WV 26241
 Phone #: 304-636-3886
 Fax #: 304 636 5108
 Email : J.Brown@polino.com

Name : Mark A. Stout
 Company: Mark's Dozer Service
 Address: Box 267
Flemington WV. 26347
 Phone#: 304-677-1734
 Fax #:
 Email : markstout59@yahoo.com

MANDATORY PRE-BID SIGN-IN ATTENDANCE SHEET

6

RFQ # : DEP14908 Bid Date: 04/20/2010
 Project: Tygart Valley Mining Co. Pre-Bid Date: 03/23/10
U-2002-95

Name : JEFFREY S. LAURITA
 Company: SCJL Co-Leasing Corp Inc
 Address: 8 HUNTER ZANE Rd
Fairmont WV 26554

Phone #: 304-290-4608
 Fax #: 304-290-8252
 Email : JS LAURITA @ Yahoo.com

Name : Ashley Allkins
 Company: Aspen Corporation
 Address: 2400 River Drive
Denver WV 25832

Phone#: 304-763-4573
 Fax #: 304-763-4591
 Email : jallkins@aspen-golf.com

Name : STEVE SZABO
 Company: PRO CONTRACTING INC.
 Address: P.O. Box 2442
CLARKSBURG, WV 26302

Phone #: 304 622-2400
 Fax #: 622-2410
 Email : procon.555@ma.rr.com

Name : Chris M. Wolfe
 Company: COVE BAN CO., LLC
 Address: P.O. Box 104
martinsburg WV 26405

Phone#: (304) 669-1722
 Fax #: (304) 457-1662
 Email : cm.wolfe73@yahoo.com

Name : GARY LONG
 Company: McCourt & Son Const.
 Address: 2790 Centralia Rd
Sutton WV 26601

Phone #: 304 765-5288
 Fax #: 304 765-5293
 Email : _____

Name : DENNIS C. ELBOW
 Company: COUGAR LP INC
 Address: PO Box 243
SIMPSON WV 26435

Phone#: 304-739-4397
 Fax #: 304-739-4401
 Email : DCE-COUGARLP@EARTHWINK.NET

Name : MIKE FURLOW
 Company: ARC ASSOC.
 Address: 3 TERRILL AVE
BURKININGTON, WV

Phone #: 330-620-1232
 Fax #: 609-386-7951
 Email : MFURLOW@ARCASSOCIATES.COM

Name : JAMES ALLEN
 Company: JF ALLEN CO
 Address: PO Box 2019
Beckham WV 26201

Phone#: 304 472 8890
 Fax #: 304 472 8897
 Email JAMES.ALLEN@JFALLENCO.COM

MANDATORY PRE-BID SIGN-IN ATTENDANCE SHEET

7

RFQ # : DEP14908 Bid Date: 04/20/2010
 Project: Tygart Valley Mining Co. Pre-Bid Date: 03/23/10
U-2002-95 LANDOWNER

Name : Haris Mitchell
 Company: Eastern Among Co. Inc
 Address: P.O. Box 4108
Charleston WV
25364
 Phone #: 304-414-0255
 Fax #: 304-414-0256
 Email : easternava@hotmail.com

Name : Brian Wentz
 Company: land owner
 Address: Rt 1 Box 325
Bridges & WV
 Phone# : 304 457-5370
 Fax # :
 Email : NOT A BIDDER

Name : Thane Ryder
 Company: RBS Inc.
 Address: PO Box 490
White Sulphur Springs
WV 24986
 Phone #: 304-645-2277
 Fax #: 304-645-2597
 Email : for @ RBS Inc. com

Name : Phillip Hines
 Company: A.T.I. Express Transport
 Address: PO Box 909
Chapman WV 26250
 Phone# : 1
 Fax # :
 Email :

Name : Dana Vincent
 Company: Breakaway Inc.
 Address: 1075 old Turnpike rd
Sutton WV 26209
 Phone #: 765-5317
 Fax #: 765-5389
 Email :

Name : Trampus Jennings
 Company: Sand Hill LLC
 Address: 1192 Evansville Pike
Thorton WV 26440
(hydro seeding sub contractor)
 Phone# : 304 892 2901
 Fax # :
 Email :

Fertilizer
 Seed mulch
 Lime
 For grass
 Not 4PK

Name : Roger Collier Jr
 Company: Collier Building & Construction Inc.
 Address: 3408 Curry Creek Rd
Fluorndale, WV
26021
 Phone #: 304-765-3521
 Fax #: 304-765-3721
 Email : Collier Building & Construction

Name : David McCoy
 Company: WV DEP
 Address: 105 S. Railroad
Philippi, WV 26416
 Phone# : 304-457-3219
 Fax # :
 Email :

BID BOND

KNOW ALL MEN BY THESE PRESENTS, That we, the undersigned, R. B. S., Inc.
of White Sulphur Springs, West Virginia, as Principal, and Fidelity and Deposit Company of Maryland of Baltimore, Maryland, a corporation organized and existing under the laws of the State of Maryland with its principal office in the City of Baltimore, MD, as Surety, are held and firmly bound unto the State of West Virginia, as Obligee, in the penal sum of Five Percent of the Amount Bid (\$ ----- 5% -----) for the payment of which, well and truly to be made, we jointly and severally bind ourselves, our heirs, administrators, executors, successors and assigns.

The Condition of the above obligation is such that whereas the Principal has submitted to the Purchasing Section of the Department of Administration a certain bid or proposal, attached hereto and made a part hereof, to enter into a contract in writing for Reclamation: Restoration of 17 Acres near Galloway, Barbour County, WV on abandon land of Tygart Valley Mining, Inc., WVDEP # 14908.

NOW THEREFORE,

- (a) If said bid shall be rejected, or
- (b) If said bid shall be accepted and the Principal shall enter into a contract in accordance with the bid or proposal attached hereto and shall furnish any other bonds and insurance required by the bid or proposal, and shall in all other respects perform the agreement created by the acceptance of said bid, then this obligation shall be null and void, otherwise this obligation shall remain in full force and effect. It is expressly understood and agreed that the liability of the Surety for any and all claims hereunder shall, in no event, exceed the penal amount of this obligation as herein stated.

The Surety, for the value received, hereby stipulates and agrees that the obligations of said Surety and its bond shall be in no way impaired or affected by any extension of the time within which the Obligee may accept such bid, and said Surety does hereby waive notice of any such extension.

IN WITNESS WHEREOF, Principal and Surety have hereunto set their hands and seals, and such of them as are corporations have caused their corporate seals to be affixed hereunto and these presents to be signed by their proper officers, this 20th day of April, 20 10.

Principal Corporate Seal

R. B. S., Inc.
(Name of Principal)
By [Signature]
(Must be President or Vice President)
Vice President
(Title)

Surety Corporate Seal

Fidelity and Deposit Company of Maryland
(Name of Surety)
[Signature]
Attorney-in-Fact

IMPORTANT – Surety executing bonds must be licensed in West Virginia to transact surety insurance. Raised corporate seals must be affixed, a power of attorney must be attached.

Power of Attorney
FIDELITY AND DEPOSIT COMPANY OF MARYLAND

KNOW ALL MEN BY THESE PRESENTS: That the FIDELITY AND DEPOSIT COMPANY OF MARYLAND, a corporation of the State of Maryland, by M. P. HAMMOND, Vice President, and ERIC D. BARNES, Assistant Secretary, in pursuance of authority granted by Article VI, Section 2, of the By-Laws of said Company, which are set forth on the reverse side hereof and are hereby certified to be in full force and effect on the date hereof, does hereby nominate, constitute and appoint **A. L. STANCHINA, of Moneta, Virginia**, its true and lawful agent and Attorney-in-Fact, to make, execute, seal and deliver, for, and on its behalf as surety, and as its act and deed, ~~any and all bonds and undertakings~~, and the execution of such bonds or undertakings in pursuance of these presents, shall be as binding upon said Company, as fully and amply, to all intents and purposes, as if they had been duly executed and acknowledged by the regularly elected officers of the Company at its office in Baltimore, Md., in their own proper persons. This power of attorney revokes that issued on behalf of A. L. STANCHINA, dated June 14, 2004.

The said Assistant Secretary does hereby certify that the extract set forth on the reverse side hereof is a true copy of Article VI, Section 2, of the By-Laws of said Company, and is now in force.

IN WITNESS WHEREOF, the said Vice-President and Assistant Secretary have hereunto subscribed their names and affixed the Corporate Seal of the said FIDELITY AND DEPOSIT COMPANY OF MARYLAND, this 28th day of July, A.D. 2004.

ATTEST:

FIDELITY AND DEPOSIT COMPANY OF MARYLAND



Eric D. Barnes

Eric D. Barnes

By:

M. P. Hammond

M. P. Hammond

Vice President

State of Maryland } ss:
City of Baltimore }

**FOR YOUR PROTECTION,
LOOK FOR THE ZURICH WATERMARK**

On this 28th day of July, A.D. 2004, before the subscriber, a Notary Public of the State of Maryland, duly commissioned and qualified, came M. P. HAMMOND, Vice President, and ERIC D. BARNES, Assistant Secretary of the FIDELITY AND DEPOSIT COMPANY OF MARYLAND, to me personally known to be the individuals and officers described in and who executed the preceding instrument, and they each acknowledged the execution of the same, and being by me duly sworn, severally and each for himself depose and saith, that they are the said officers of the Company aforesaid, and that the seal affixed to the preceding instrument is the Corporate Seal of said Company, and that the said Corporate Seal and their signatures as such officers were duly affixed and subscribed to the said instrument by the authority and direction of the said Corporation.

IN TESTIMONY WHEREOF, I have hereunto set my hand and affixed my Official Seal the day and year first above written.



Dennis R. Hayden

Dennis R. Hayden

Notary Public

My Commission Expires: February 1, 2009

EXTRACT FROM BY-LAWS OF FIDELITY AND DEPOSIT COMPANY OF MARYLAND

"Article VI, Section 2. The Chairman of the Board, or the President, or any Executive Vice-President, or any of the Senior Vice-Presidents or Vice-Presidents specially authorized so to do by the Board of Directors or by the Executive Committee, shall have power, by and with the concurrence of the Secretary or any one of the Assistant Secretaries, to appoint Resident Vice-Presidents, Assistant Vice-Presidents and Attorneys-in-Fact as the business of the Company may require, or to authorize any person or persons to execute on behalf of the Company any bonds, undertakings, recognizances, stipulations, policies, contracts, agreements, deeds, and releases and assignments of judgements, decrees, mortgages and instruments in the nature of mortgages,...and to affix the seal of the Company thereto."

CERTIFICATE

I, the undersigned, Assistant Secretary of the FIDELITY AND DEPOSIT COMPANY OF MARYLAND, do hereby certify that the foregoing Power of Attorney is still in full force and effect on the date of this certificate; and I do further certify that the Vice-President who executed the said Power of Attorney was one of the additional Vice-Presidents specially authorized by the Board of Directors to appoint any Attorney-in-Fact as provided in Article VI, Section 2, of the By-Laws of the FIDELITY AND DEPOSIT COMPANY OF MARYLAND.

This Power of Attorney and Certificate may be signed by facsimile under and by authority of the following resolution of the Board of Directors of the FIDELITY AND DEPOSIT COMPANY OF MARYLAND at a meeting duly called and held on the 10th day of May, 1990.

RESOLVED: "That the facsimile or mechanically reproduced seal of the company and facsimile or mechanically reproduced signature of any Vice-President, Secretary, or Assistant Secretary of the Company, whether made heretofore or hereafter, wherever appearing upon a certified copy of any power of attorney issued by the Company, shall be valid and binding upon the Company with the same force and effect as though manually affixed."

IN TESTIMONY WHEREOF, I have hereunto subscribed my name and affixed the corporate seal of the said Company,

this 20th day of April, 2010.

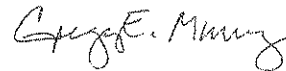

Assistant Secretary



State of West Virginia
DRUG FREE WORKPLACE CONFORMANCE AFFIDAVIT
West Virginia Code §21-1D-5

STATE OF WV

COUNTY OF Greenbrier, TO-WIT:

I, William Snyder, after being first duly sworn, depose and state as follows:

- 1. I am an employee of R.B.S. Inc.; and,
(Company Name)
- 2. I do hereby attest that R.B.S. Inc.
(Company Name)

maintains a valid written drug free workplace policy and that such policy is in compliance with **West Virginia Code §21-1D-5**.

The above statements are sworn to under the penalty of perjury.

R.B.S. Inc.
(Company Name)

By: [Signature]

Title: V.P., RBS Inc.

Date: 16 April 2010

Taken, subscribed and sworn to before me this 16th day of April, 2010.

By Commission expires April 1, 2017

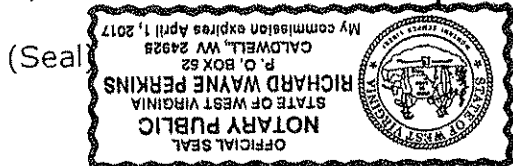

[Signature]
(Notary Public)

THIS AFFIDAVIT MUST BE SUBMITTED WITH THE BID IN ORDER TO COMPLY WITH WV CODE PROVISIONS. FAILURE TO INCLUDE THE AFFIDAVIT WITH THE BID SHALL RESULT IN DISQUALIFICATION OF THE BID.

STATE OF WEST VIRGINIA
Purchasing Division

PURCHASING AFFIDAVIT

West Virginia Code §5A-3-10a states: No contract or renewal of any contract may be awarded by the state or any of its political subdivisions to any vendor or prospective vendor when the vendor or prospective vendor or a related party to the vendor or prospective vendor is a debtor and the debt owed is an amount greater than one thousand dollars in the aggregate.

DEFINITIONS:

"Debt" means any assessment, premium, penalty, fine, tax or other amount of money owed to the state or any of its political subdivisions because of a judgment, fine, permit violation, license assessment, defaulted workers' compensation premium, penalty or other assessment presently delinquent or due and required to be paid to the state or any of its political subdivisions, including any interest or additional penalties accrued thereon.

"Debtor" means any individual, corporation, partnership, association, limited liability company or any other form or business association owing a debt to the state or any of its political subdivisions. "Political subdivision" means any county commission; municipality; county board of education; any instrumentality established by a county or municipality; any separate corporation or instrumentality established by one or more counties or municipalities, as permitted by law; or any public body charged by law with the performance of a government function or whose jurisdiction is coextensive with one or more counties or municipalities. "Related party" means a party, whether an individual, corporation, partnership, association, limited liability company or any other form or business association or other entity whatsoever, related to any vendor by blood, marriage, ownership or contract through which the party has a relationship of ownership or other interest with the vendor so that the party will actually or by effect receive or control a portion of the benefit, profit or other consideration from performance of a vendor contract with the party receiving an amount that meets or exceed five percent of the total contract amount.

EXCEPTION: The prohibition of this section does not apply where a vendor has contested any tax administered pursuant to chapter eleven of this code, workers' compensation premium, permit fee or environmental fee or assessment and the matter has not become final or where the vendor has entered into a payment plan or agreement and the vendor is not in default of any of the provisions of such plan or agreement.

Under penalty of law for false swearing (*West Virginia Code* §61-5-3), it is hereby certified that the vendor affirms and acknowledges the information in this affidavit and is in compliance with the requirements as stated.

WITNESS THE FOLLOWING SIGNATURE

Vendor's Name: R.B.S. Inc.

Authorized Signature: [Handwritten Signature] Date: 16 April 2010

State of WV

County of Greenbrier, to-wit:

Taken, subscribed, and sworn to before me this 16th day of April, 2010.

My Commission expires April 1, 2017, 20 .

AFFIX SEAL HERE

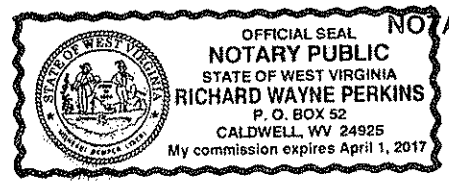

NOTARY PUBLIC Richard Wayne Perkins