



State of West Virginia  
 Department of Administration  
 Purchasing Division  
 2019 Washington Street East  
 Post Office Box 50130  
 Charleston, WV 25305-0130

# Request for Quotation

RFQ NUMBER  
 DEP14906

PAGE  
 1

ADDRESS CORRESPONDENCE TO ATTENTION OF  
 CHUCK BOWMAN  
 304-558-2157

VENDOR

\*B19160306      304-622-2400  
 PRO CONTRACTING INC  
 PO BOX 2442  
 CLARKSBURG WV 26301

SHIP TO

ENVIRONMENTAL PROTECTION  
 DEPT. OF  
 OFFICE OF SPECIAL RECLAMATION  
 105 S. RAILROAD STREET  
 PHILIPPI, WV  
 26416-9998      304-457-3219

DATE PRINTED 02/17/2010	TERMS OF SALE	SHIP VIA	F.O.B.	FREIGHT TERMS
----------------------------	---------------	----------	--------	---------------

BID OPENING DATE: 04/21/2010      BID OPENING TIME 01:30PM

LINE	QUANTITY	UOP	CAT. NO.	ITEM NUMBER	UNIT PRICE	AMOUNT
0001	1	JB		962-73		\$405,050. <sup>00</sup>
<p>RECLAMATION: RESTORATION OF LAND</p> <p>THE WEST VIRGINIA PURCHASING DIVISION, FOR THE AGENCY, THE WEST VIRGINIA DEPARTMENT OF ENVIRONMENTAL PROTECTION, IS SOLICITING BIDS FROM QUALIFIED CONTRACTORS FOR A CONTRACT TO PROVIDE ALL LABOR AND MATERIALS TO PERFORM RECLAMATION ON THE MINING OPERATION OF BUFFALO COAL COMPANY, NOW UNDER REVOKED PERMIT NUMBER(S) S-2018-88, ON A SITE CONSISTING OF APPROXIMATELY 27 ACRES LOCATED NEAR MOUNT STORM, WV, (TUCKER CO.).</p> <p>THE RECLAMATION SHALL BE PERFORMED UNDER THE GUIDANCE AND GENERAL SUPERVISION OF THE AGENT ASSIGNED TO THE PROJECT FOR THE STATE OF WEST VIRGINIA, DEPARTMENT OF ENVIRONMENTAL PROTECTION.</p> <p>A MANDATORY ON-SITE PREBID CONFERENCE SHALL BE HELD ON 03/25/2010 @ 10:00 AM. ALL INTERESTED PARTIES ARE REQUIRED TO ATTEND THIS MEETING. FAILURE TO ATTEND THE MANDATORY PRE-BID SHALL RESULT IN DISQUALIFICATION OF THE BID. NO ONE PERSON MAY REPRESENT MORE THAN ONE BIDDER.</p> <p>AN ATTENDANCE SHEET WILL BE MADE AVAILABLE FOR ALL POTENTIAL BIDDERS TO COMPLETE. THIS WILL SERVE AS THE OFFICIAL DOCUMENT VERIFYING ATTENDANCE AT THE MANDATORY PRE-BID. FAILURE TO PROVIDE YOUR COMPANY AND REPRESENTATIVE NAME ON THE ATTENDANCE SHEET WILL RESULT IN DISQUALIFICATION OF THE BID. THE STATE WILL NOT ACCEPT ANY OTHER DOCUMENTATION TO VERIFY ATTENDANCE. THE BIDDER IS RESPONSIBLE FOR ENSURING THEY HAVE COMPLETED THE INFOR</p>						

RECEIVED  
 APR 21 10:03  
 PURCHASING DIVISION  
 STATE OF WV

SEE REVERSE SIDE FOR TERMS AND CONDITIONS

SIGNATURE: *[Signature]*      TELEPHONE: 304-622-2400      DATE: 4-20-10

TITLE: Vice President      FEIN: 36-3348227      ADDRESS CHANGES TO BE NOTED ABOVE

WHEN RESPONDING TO RFQ, INSERT NAME AND ADDRESS IN SPACE ABOVE LABELED 'VENDOR'

**GENERAL TERMS & CONDITIONS  
REQUEST FOR QUOTATION (RFQ) AND REQUEST FOR PROPOSAL (RFP)**

1. Awards will be made in the best interest of the State of West Virginia.
2. The State may accept or reject in part, or in whole, any bid.
3. Prior to any award, the apparent successful vendor must be properly registered with the Purchasing Division and have paid the required \$125 fee.
4. All services performed or goods delivered under State Purchase Order/Contracts are to be continued for the term of the Purchase Order/Contracts, contingent upon funds being appropriated by the Legislature or otherwise being made available. In the event funds are not appropriated or otherwise available for these services or goods this Purchase Order/Contract becomes void and of no effect after June 30.
5. Payment may only be made after the delivery and acceptance of goods or services.
6. Interest may be paid for late payment in accordance with the *West Virginia Code*.
7. Vendor preference will be granted upon written request in accordance with the *West Virginia Code*.
8. The State of West Virginia is exempt from federal and state taxes and will not pay or reimburse such taxes.
9. The Director of Purchasing may cancel any Purchase Order/Contract upon 30 days written notice to the seller.
10. The laws of the State of West Virginia and the *Legislative Rules* of the Purchasing Division shall govern the purchasing process.
11. Any reference to automatic renewal is hereby deleted. The Contract may be renewed only upon mutual written agreement of the parties.
12. **BANKRUPTCY:** In the event the vendor/contractor files for bankruptcy protection, the State may deem this contract null and void, and terminate such contract without further order.
13. **HIPAA BUSINESS ASSOCIATE ADDENDUM:** The West Virginia State Government HIPAA Business Associate Addendum (BAA), approved by the Attorney General, is available online at [www.state.wv.us/admin/purchase/vrc/hipaa.htm](http://www.state.wv.us/admin/purchase/vrc/hipaa.htm) and is hereby made part of the agreement. Provided that the Agency meets the definition of a Cover Entity (45 CFR §160.103) and will be disclosing Protected Health Information (45 CFR §160.103) to the vendor.
14. **CONFIDENTIALITY:** The vendor agrees that he or she will not disclose to anyone, directly or indirectly, any such personally identifiable information or other confidential information gained from the agency, unless the individual who is the subject of the information consents to the disclosure in writing or the disclosure is made pursuant to the agency's policies, procedures, and rules. Vendor further agrees to comply with the Confidentiality Policies and Information Security Accountability Requirements, set forth in <http://www.state.wv.us/admin/purchase/privacy/noticeConfidentiality.pdf>.
15. **LICENSING:** Vendors must be licensed and in good standing in accordance with any and all state and local laws and requirements by any state or local agency of West Virginia, including, but not limited to, the West Virginia Secretary of State's Office, the West Virginia Tax Department, and the West Virginia Insurance Commission. The vendor must provide all necessary releases to obtain information to enable the director or spending unit to verify that the vendor is licensed and in good standing with the above entities.
16. **ANTITRUST:** In submitting a bid to any agency for the State of West Virginia, the bidder offers and agrees that if the bid is accepted the bidder will convey, sell, assign or transfer to the State of West Virginia all rights, title and interest in and to all causes of action it may now or hereafter acquire under the antitrust laws of the United States and the State of West Virginia for price fixing and/or unreasonable restraints of trade relating to the particular commodities or services purchased or acquired by the State of West Virginia. Such assignment shall be made and become effective at the time the purchasing agency tenders the initial payment to the bidder.

I certify that this bid is made without prior understanding, agreement, or connection with any corporation, firm, limited liability company, partnership, or person or entity submitting a bid for the same material, supplies, equipment or services and is in all respects fair and without collusion or Fraud. I further certify that I am authorized to sign the certification on behalf of the bidder or this bid.

---

**INSTRUCTIONS TO BIDDERS**

1. Use the quotation forms provided by the Purchasing Division. Complete all sections of the quotation form.
2. Items offered must be in compliance with the specifications. Any deviation from the specifications must be clearly indicated by the bidder. Alternates offered by the bidder as **EQUAL** to the specifications must be clearly defined. A bidder offering an alternate should attach complete specifications and literature to the bid. The Purchasing Division may waive minor deviations to specifications.
3. Unit prices shall prevail in case of discrepancy. All quotations are considered F.O.B. destination unless alternate shipping terms are clearly identified in the quotation.
4. All quotations must be delivered by the bidder to the office listed below prior to the date and time of the bid opening. Failure of the bidder to deliver the quotations on time will result in bid disqualifications: Department of Administration, Purchasing Division, 2019 Washington Street East, P.O. Box 50130, Charleston, WV 25305-0130
5. Communication during the solicitation, bid, evaluation or award periods, except through the Purchasing Division, is strictly prohibited (W.Va. C.S.R. §148-1-6.6).



State of West Virginia  
 Department of Administration  
 Purchasing Division  
 2019 Washington Street East  
 Post Office Box 50130  
 Charleston, WV 25305-0130

# Request for Quotation

RFQ NUMBER  
**DEP14906**

PAGE  
**2**

ADDRESS CORRESPONDENCE TO ATTENTION OF  
**CHUCK BOWMAN**  
**304-558-2157**

VENDOR

\*B19160306      304-622-2400  
**PRO CONTRACTING INC**  
**PO BOX 2442**  
  
**CLARKSBURG WV 26301**

SHIP TO

**ENVIRONMENTAL PROTECTION**  
**DEPT. OF**  
**OFFICE OF SPECIAL RECLAMATION**  
**105 S. RAILROAD STREET**  
**PHILIPPI, WV**  
**26416-9998      304-457-3219**

DATE PRINTED <b>02/17/2010</b>	TERMS OF SALE	SHIP VIA	F.O.B.	FREIGHT TERMS
-----------------------------------	---------------	----------	--------	---------------

BID OPENING DATE: **04/21/2010**      BID OPENING TIME **01:30PM**

LINE	QUANTITY	UOP	CAT NO	ITEM NUMBER	UNIT PRICE	AMOUNT
<p>MATION REQUIRED ON THE ATTENDANCE SHEET. THE PURCHASING DIVISION AND THE STATE AGENCY WILL NOT ASSUME ANY RESPONSIBILITY FOR A BIDDER'S FAILURE TO COMPLETE THE PRE-BID ATTENDANCE SHEET. IN ADDITION, WE REQUEST THAT ALL POTENTIAL BIDDERS INCLUDE THEIR E-MAIL ADDRESS AND FAX NUMBER.</p> <p>ALL POTENTIAL BIDDERS ARE REQUESTED TO ARRIVE PRIOR TO THE STARTING TIME FOR THE PRE-BID. BIDDERS WHO ARRIVE LATE, BUT PRIOR TO THE DISMISSAL OF THE TECHNICAL PORTION OF THE PRE-BID WILL BE PERMITTED TO SIGN IN. BIDDERS WHO ARRIVE AFTER CONCLUSION OF THE TECHNICAL PORTION OF THE PRE-BID, BUT DURING ANY SUBSEQUENT PART OF THE PRE-BID WILL NOT BE PERMITTED TO SIGN THE ATTENDANCE SHEET.</p> <p>DIRECTIONS TO PRE-BID: IN TUCKER COUNTY, FROM THE INTERSECTION OF SR 32 AND 93 NEAR DAVIS, GO 6.2 MILES EAST ON RT 93 TO THE PRIVATE HAULROAD ON THE LEFT (METTIKI E-MINE PREPARATION PLANT ENTRANCE). YOU WILL HAVE TO CHECK IN AT THE METTIKI GUARD HOUSE AND THEN PROCEED THROUGH THEIR SITE TO GET TO THE SITE.</p> <p>ALL WORK MUST BE COMPLETED IN ACCORDANCE WITH THE PLANS AND SPECIFICATIONS PREPARED BY THE DEPARTMENT OF ENVIRONMENTAL PROTECTION AND PURCHASE ORDER ISSUED BY THE DEPARTMENT OF ADMINISTRATION, DIVISION OF PURCHASING.</p> <p>EXHIBIT 5</p> <p>WEST VIRGINIA CODE 21-ID-5 PROVIDES THAT: ANY SOLICITATION FOR A PUBLIC IMPROVEMENT CONSTRUCTION CONTRACT REQUIRES EACH VENDOR THAT SUBMITS A BID FOR THE WORK TO SUBMIT AT THE SAME TIME AN AFFIDAVIT OF COMPLIANCE WITH THE BID. THE ENCLOSED PURCHASING AFFIDAVIT MUST BE SIGNED AND SUBMITTED WITH THE BID AS EVIDENCE OF THE VENDOR'S COMPLIANCE WITH THE PROVISIONS OF ARTICLE 1D,</p>						

SEE REVERSE SIDE FOR TERMS AND CONDITIONS

SIGNATURE	TELEPHONE	DATE
TITLE	FEIN	ADDRESS CHANGES TO BE NOTED ABOVE

WHEN RESPONDING TO RFQ, INSERT NAME AND ADDRESS IN SPACE ABOVE LABELED 'VENDOR'



State of West Virginia  
 Department of Administration  
 Purchasing Division  
 2019 Washington Street East  
 Post Office Box 50130  
 Charleston, WV 25305-0130

# Request for Quotation

RFQ NUMBER  
**DEP14906**

PAGE  
**3**

ADDRESS CORRESPONDENCE TO ATTENTION OF  
**CHUCK BOWMAN  
 304-558-2157**

**VENDOR**  
 \*B19160306      304-622-2400  
 PRO CONTRACTING INC  
 PO BOX 2442  
 CLARKSBURG WV 26301

**SHIP TO**  
 ENVIRONMENTAL PROTECTION  
 DEPT. OF  
 OFFICE OF SPECIAL RECLAMATION  
 105 S. RAILROAD STREET  
 PHILIPPI, WV  
 26416-9998      304-457-3219

DATE PRINTED	TERMS OF SALE	SHIP VIA	F.O.B.	FREIGHT TERMS
02/17/2010				

BID OPENING DATE: **04/21/2010**      BID OPENING TIME **01:30PM**

LINE	QUANTITY	UOP	CAT NO	ITEM NUMBER	UNIT PRICE	AMOUNT
<p>CHAPTER 21 OF THE WEST VIRGINIA CODE. FAILURE TO SUBMIT THE SIGNED PURCHASING AFFIDAVIT WITH THE BID SHALL RESULT IN DISQUALIFICATION OF SUCH BID.</p> <p>NOTICE TO PROCEED: THIS CONTRACT IS TO BE PERFORMED WITH 365 CALENDAR DAYS AFTER THE NOTICE TO PROCEED IS RECEIVED. UNLESS OTHERWISE SPECIFIED, THE FULLY EXECUTED PURCHASE ORDER WILL BE CONSIDERED NOTICE TO PROCEED.</p> <p>CANCELLATION: THE DIRECTOR OF PURCHASING RESERVES THE RIGHT TO CANCEL THIS CONTRACT IMMEDIATELY UPON WRITTEN NOTICE TO THE VENDOR IF THE MATERIALS OR WORKMANSHIP SUPPLIED ARE OF AN INFERIOR QUALITY OR DO NOT CONFORM WITH THE SPECIFICATIONS OF THE THE BID AND CONTRACT HERE IN.</p> <p>WAGE RATES: THE CONTRACTOR OR SUBCONTRACTOR SHALL PAY THE HIGHER OF THE U.S. DEPARTMENT OF LABOR MINIMUM WAGE RATES AS ESTABLISHED FOR TUCKER COUNTY, PURSUANT TO WEST VIRGINIA CODE 21-5A, ET, SEQ. (PREVAILING WAGE RATES APPLY TO THIS PROJECT)</p> <p>ARBITRATION: ANY REFERENCES MADE TO ARBITRATION OR INTEREST FOR PAYMENTS DUE (EXCEPT FOR ANY INTEREST REQUIRED BY STATE LAW) CONTAINED IN THIS CONTRACT OR IN ANY AMERICAN INSTITUTE OF ARCHITECTS DOCUMENTS PERTAINING TO THIS CONTRACT ARE HEREBY DELETED.</p> <p>WORKERS' COMPENSATION: VENDOR IS REQUIRED TO PROVIDE A CERTIFICATE FROM WORKERS' COMPENSATION IF SUCCESSFUL.</p> <p>ALL OF THE ITEMS CHECKED BELOW WILL BE A REQUIREMENT OF THIS CONTRACT:</p> <p>(XX) INSURANCE: SUCCESSFUL VENDOR SHALL FURNISH PROOF</p>						

SEE REVERSE SIDE FOR TERMS AND CONDITIONS

SIGNATURE	TELEPHONE	DATE
TITLE	FEIN	ADDRESS CHANGES TO BE NOTED ABOVE

WHEN RESPONDING TO RFQ, INSERT NAME AND ADDRESS IN SPACE ABOVE LABELED 'VENDOR'





State of West Virginia  
 Department of Administration  
 Purchasing Division  
 2019 Washington Street East  
 Post Office Box 50130  
 Charleston, WV 25305-0130

# Request for Quotation

RFQ NUMBER  
 DEP14906

PAGE  
 5

ADDRESS CORRESPONDENCE TO ATTENTION OF  
 CHUCK BOWMAN  
 304-558-2157

**VENDOR**  
 \*B19160306 304-622-2400  
 PRO CONTRACTING INC  
 PO BOX 2442  
 CLARKSBURG WV 26301

**SHIP TO**  
 ENVIRONMENTAL PROTECTION  
 DEPT. OF  
 OFFICE OF SPECIAL RECLAMATION  
 105 S. RAILROAD STREET  
 PHILIPPI, WV  
 26416-9998 304-457-3219

DATE PRINTED 02/17/2010	TERMS OF SALE	SHIP VIA	FOB	FREIGHT TERMS
BID OPENING DATE: 04/21/2010		BID OPENING TIME 01:30PM		

LINE	QUANTITY	UOP	CAT NO	ITEM NUMBER	UNIT PRICE	AMOUNT
<p>LICENSE. APPLICATIONS FOR A CONTRACTORS LICENSE MAY BE MADE BY CONTACTING THE WEST VIRGINIA DIVISION OF LABOR CAPITOL COMPLEX, BUILDING 3, ROOM 319, CHARLESTON, WV 25305. TELEPHONE: (304) 558-7890.</p> <p>WEST VIRGINIA STATE CODE 21-11-11 REQUIRES ANY PROSPECTIVE BIDDER TO INCLUDE THE CONTRACTORS LICENSE NUMBER ON THEIR BID.</p> <p>BIDDER TO COMPLETE:            CONTRACTORS NAME: .... <i>Pro Contracting, Inc...</i>            CONTRACTORS LICENSE NO.: <i>WV.0446.70</i>.....</p> <p>THE SUCCESSFUL BIDDER WILL BE REQUIRED TO FURNISH A COPY OF THEIR CONTRACTORS LICENSE PRIOR TO ISSUANCE OF A PURCHASE ORDER/CONTRACT.</p> <p>APPLICABLE LAW</p> <p>THE WEST VIRGINIA STATE CODE, PURCHASING DIVISION RULES AND REGULATIONS, AND THE INFORMATION PROVIDED IN THE "REQUEST FOR QUOTATION" ISSUED BY THE PURCHASING DIVISION IS THE SOLE AUTHORITY GOVERNING THIS PROCUREMENT.</p> <p>ANY INFORMATION PROVIDED IN SPECIFICATION MANUALS, OR ANY OTHER SOURCE, VERBAL OR WRITTEN, WHICH CONTRADICTS OR ALTERS THE INFORMATION PROVIDED FROM THE SOURCES AS DESCRIBED IN THE ABOVE PARAGRAPH IS VOID AND OF NO EFFECT.</p> <p>BANKRUPTCY: IN THE EVENT THE VENDOR/CONTRACTOR FILES FOR BANKRUPTCY PROTECTION, THE STATE MAY DEEM THIS CONTRACT NULL AND VOID AND TERMINATE SUCH CONTRACT WITHOUT FURTHER ORDER.</p>						

SEE REVERSE SIDE FOR TERMS AND CONDITIONS

SIGNATURE <i>[Signature]</i>	TELEPHONE 304-622-2400	DATE 4-20-10
TITLE Vice President	FEN 26-3348227	ADDRESS CHANGES TO BE NOTED ABOVE

WHEN RESPONDING TO RFQ, INSERT NAME AND ADDRESS IN SPACE ABOVE LABELED 'VENDOR'



State of West Virginia  
 Department of Administration  
 Purchasing Division  
 2019 Washington Street East  
 Post Office Box 50130  
 Charleston, WV 25305-0130

# Request for Quotation

RFQ NUMBER  
 DEP14906

PAGE  
 6

ADDRESS CORRESPONDENCE TO ATTENTION OF  
 CHUCK BOWMAN  
 304-558-2157

VENDOR

\*B19160306      304-622-2400  
 PRO CONTRACTING INC  
 PO BOX 2442  
  
 CLARKSBURG WV 26301

SHIP TO

ENVIRONMENTAL PROTECTION  
 DEPT. OF  
 OFFICE OF SPECIAL RECLAMATION  
 105 S. RAILROAD STREET  
 PHILIPPI, WV  
 26416-9998      304-457-3219

DATE PRINTED	TERMS OF SALE	SHIP VIA	F.O.B	FREIGHT TERMS
02/17/2010				

BID OPENING DATE: **04/21/2010**      BID OPENING TIME **01:30PM**

LINE	QUANTITY	UOP	CAT NO	ITEM NUMBER	UNIT PRICE	AMOUNT
<p>PREFERENCE FOR USE OF DOMESTIC STEEL PRODUCTS</p> <p>1. EXCEPT WHEN AUTHORIZED BY THE DIRECTOR OF THE PURCHASING DIVISION PURSUANT TO SUBSECTION 2 BELOW, NO CONTRACTOR MAY USE OR SUPPLY STEEL PRODUCTS FOR A STATE CONTRACT PROJECT OTHER THAN THOSE STEEL PRODUCTS MADE IN THE UNITED STATES. AS USED IN THIS CONTRACT,</p> <p>A. "STATE CONTRACT PROJECT" MEANS ANY ERECTION OR CONSTRUCTION OF, OR ANY ADDITION TO, ALTERATION OF OR OTHER IMPROVEMENT TO ANY BUILDING OR STRUCTURE, INCLUDING, BUT NOT LIMITED TO, ROADS OR HIGHWAYS, OR THE INSTALLATION OF ANY HEATING OR COOLING OR VENTILATING PLANTS OR OTHER EQUIPMENT, OR THE SUPPLY OF AND MATERIALS FOR SUCH PROJECTS, PURSUANT TO A CONTRACT WITH THE STATE OF WEST VIRGINIA FOR WHICH BIDS WERE SOLICITED ON OR AFTER JUNE 6, 2001.</p> <p>B. "STEEL PRODUCTS" MEANS PRODUCTS ROLLED, FORMED, SHAPED, DRAWN, EXTRUDED, FORGED, CAST, FABRICATED OR OTHERWISE SIMILARLY PROCESSED, OR PROCESSED BY A COMBINATION OF TWO OR MORE OF SUCH OPERATIONS, FROM STEEL MADE BY THE OPEN HEARTH, BASIC OXYGEN, ELECTRIC FURNACE, BESSEMER OR OTHER STEEL MAKING PROCESS.</p> <p>C. "UNITED STATES" MEANS THE UNITED STATES OF AMERICA AND INCLUDES ALL TERRITORY, CONTINENTAL OR INSULAR, SUBJECT TO THE JURISDICTION OF THE UNITED STATES.</p> <p>2. THE DIRECTOR OF THE PURCHASING DIVISION MAY, IN WRITING, AUTHORIZE THE USE OF FOREIGN STEEL</p>						

SEE REVERSE SIDE FOR TERMS AND CONDITIONS

SIGNATURE	TELEPHONE	DATE
TITLE	FEIN	ADDRESS CHANGES TO BE NOTED ABOVE

WHEN RESPONDING TO RFQ, INSERT NAME AND ADDRESS IN SPACE ABOVE LABELED 'VENDOR'



State of West Virginia  
 Department of Administration  
 Purchasing Division  
 2019 Washington Street East  
 Post Office Box 50130  
 Charleston, WV 25305-0130

# Request for Quotation

RFQ NUMBER  
**DEP14906**

PAGE  
**7**

ADDRESS CORRESPONDENCE TO ATTENTION OF  
**CHUCK BOWMAN**  
**304-558-2157**

VENDOR

\*B19160306      304-622-2400  
 PRO CONTRACTING INC  
 PO BOX 2442  
 CLARKSBURG WV 26301

SHIP TO

ENVIRONMENTAL PROTECTION  
 DEPT. OF  
 OFFICE OF SPECIAL RECLAMATION  
 105 S. RAILROAD STREET  
 PHILIPPI, WV  
 26416-9998      304-457-3219

DATE PRINTED <b>02/17/2010</b>	TERMS OF SALE	SHIP VIA	F.O.B.	FREIGHT TERMS
-----------------------------------	---------------	----------	--------	---------------

BID OPENING DATE: **04/21/2010**      BID OPENING TIME **01:30PM**

LINE	QUANTITY	UOP	CAT NO.	ITEM NUMBER	UNIT PRICE	AMOUNT
<p>PRODUCTS IF:</p> <p>A. THE COST FOR EACH CONTRACT ITEM USED DOES NOT EXCEED ONE TENTH OF ONE PERCENT (.1%) OF THE TOTAL CONTRACT COST OR TWO THOUSAND FIVE HUNDRED DOLLARS (2,500.00), WHICHEVER IS GREATER. FOR THE PURPOSES OF THIS SECTION, THE COST IS THE VALUE OF THE STEEL PRODUCT AS DELIVERED TO THE PROJECT OR,</p> <p>B. THE DIRECTOR OF THE PURCHASING DIVISION DETERMINES THAT SPECIFIED STEEL MATERIALS ARE NOT PRODUCED IN THE UNITED STATES IN SUFFICIENT QUANTITY OR OTHERWISE ARE NOT REASONABLY AVAILABLE TO MEET CONTRACT REQUIREMENTS.</p> <p>3. A CONTRACTOR WHO USES STEEL PRODUCTS IN VIOLATION OF THIS SECTION MAY BE SUBJECT TO CIVIL PENALTIES PURSUANT TO WV CODE SECTION 5A-3-56.</p> <p>REV. 10/01/01</p> <p>EXHIBIT 7</p> <p>DOMESTIC ALUMINUM, GLASS &amp; STEEL IN PUBLIC WORKS PROJECTS</p> <p>IN ACCORDANCE WITH WEST VIRGINIA CODE 5-19-1 ET., SEQ., EVERY CONTRACT FOR CONSTRUCTION, RECONSTRUCTION, ALTERATION, REPAIR, IMPROVEMENT OR MAINTENANCE OF PUBLIC WORKS, WHERE THE COST IS MORE THAN \$50,000 AND, IN THE CASE OF STEEL ONLY, WHERE THE COST OF STEEL IS MORE THAN \$50,000 OR WHERE MORE THAN 10,000 POUNDS OF STEEL ARE REQUIRED, THE STATE WILL ACCEPT ONLY ALUMINUM GLASS, OR STEEL PRODUCTS PRODUCED IN THE UNITED STATES</p>						

SEE REVERSE SIDE FOR TERMS AND CONDITIONS

SIGNATURE	TELEPHONE	DATE
TITLE	FEIN	ADDRESS CHANGES TO BE NOTED ABOVE

WHEN RESPONDING TO RFQ, INSERT NAME AND ADDRESS IN SPACE ABOVE LABELED 'VENDOR'





State of West Virginia  
 Department of Administration  
 Purchasing Division  
 2019 Washington Street East  
 Post Office Box 50130  
 Charleston, WV 25305-0130

# Request for Quotation

RFQ NUMBER  
 DEP14906

PAGE  
 8

ADDRESS CORRESPONDENCE TO ATTENTION OF  
 CHUCK BOWMAN  
 304-558-2157

PROPERTY

\*B19160306      304-622-2400  
 PRO CONTRACTING INC  
 PO BOX 2442  
 CLARKSBURG WV 26301

SHIP TO

ENVIRONMENTAL PROTECTION  
 DEPT. OF  
 OFFICE OF SPECIAL RECLAMATION  
 105 S. RAILROAD STREET  
 PHILIPPI, WV  
 26416-9998      304-457-3219

DATE PRINTED	TERMS OF SALE	SHIP VIA	FOB	FREIGHT TERMS
02/17/2010				

BID OPENING DATE: 04/21/2010      BID OPENING TIME 01:30PM

LINE	QUANTITY	UOP	CAT NO	ITEM NUMBER	UNIT PRICE	AMOUNT
<p>IN ADDITION, ITEMS OF MACHINERY OR EQUIPMENT PURCHASED FOR USE AT THE SITE OF PUBLIC WORKS SHALL BE MADE OF DOMESTIC ALUMINUM, GLASS OR STEEL, UNLESS THE COST OF THE PRODUCT IS LESS THAN \$50,000 OR LESS THAN 10,000 POUNDS OF STEEL ARE USED IN PUBLIC WORKS PROJECTS.</p> <p>FOREIGN MADE ALUMINUM, GLASS OR STEEL PRODUCTS MAY BE ACCEPTED ONLY IF THE COST OF DOMESTIC PRODUCTS IS FOUND TO BE UNREASONABLE. SUCH COST IS UNREASONABLE IF IT IS 20% OR MORE HIGHER THAN THE BID PRICE FOR FOREIGN MADE PRODUCTS. IF THE DOMESTIC ALUMINUM, GLASS OR STEEL PRODUCTS TO BE SUPPLIED OR PRODUCED IN A "SUBSTANTIAL LABOR SURPLUS AREA", AS DEFINED BY THE UNITED STATES DEPARTMENT OF LABOR, FOREIGN PRODUCTS MAY BE SUPPLIED ONLY IF DOMESTIC PRODUCTS ARE 30% OR MORE HIGHER IN PRICE THAN THE FOREIGN MADE PRODUCTS.</p> <p>IF, PRIOR TO THE AWARD OF A CONTRACT UNDER THE ABOVE PROVISIONS, THE SPENDING OFFICER OF THE SPENDING UNIT DETERMINES THAT THERE EXISTS A BID FOR LIKE FOREIGN ALUMINUM, GLASS OR STEEL THAT IS REASONABLE AND LOWER THAN THE LOWEST BID DOMESTIC PRODUCTS, THE SPENDING OFFICE MAY REQUEST, IN WRITING, A REEVALUATION AND REDUCTION IN THE LOWEST BID FOR SUCH DOMESTIC PRODUCTS ALL VENDORS MUST INDICATE IN THEIR BID IF THEY ARE SUPPLYING FOREIGN ALUMINUM, GLASS OR STEEL.</p> <p>REV. 3/88</p> <p>EXHIBIT 9</p> <p>NOTICE FOR ISSUANCE &amp; ACKNOWLEDGEMENT OF CONSTRUCTION PROJECT ADDENDA</p> <p>THE ARCHITECT/ENGINEER AND/OR AGENCY SHALL BE REQUIRED TO ABIDE BY THE FOLLOWING SCHEDULE IN ISSUING</p>						

SEE REVERSE SIDE FOR TERMS AND CONDITIONS

SIGNATURE	TELEPHONE	DATE
-----------	-----------	------

TITLE	FEIN	ADDRESS CHANGES TO BE NOTED ABOVE
-------	------	-----------------------------------

WHEN RESPONDING TO RFQ, INSERT NAME AND ADDRESS IN SPACE ABOVE LABELED 'VENDOR'



State of West Virginia  
 Department of Administration  
 Purchasing Division  
 2019 Washington Street East  
 Post Office Box 50130  
 Charleston, WV 25305-0130

# Request for Quotation

RFQ NUMBER  
 DEP14906

PAGE  
 9

ADDRESS CORRESPONDENCE TO ATTENTION OF  
 CHUCK BOWMAN  
 304-558-2157

VENDOR

\*B19160306 304-622-2400  
 PRO CONTRACTING INC  
 PO BOX 2442  
 CLARKSBURG WV 26301

SHIP TO

ENVIRONMENTAL PROTECTION  
 DEPT. OF  
 OFFICE OF SPECIAL RECLAMATION  
 105 S. RAILROAD STREET  
 PHILIPPI, WV  
 26416-9998 304-457-3219

DATE PRINTED	TERMS OF SALE	SHIP VIA	F.O.B.	FREIGHT TERMS
02/17/2010				

BID OPENING DATE: 04/21/2010 BID OPENING TIME 01:30PM

LINE	QUANTITY	UOP	CAT NO	ITEM NUMBER	UNIT PRICE	AMOUNT
<p>CONSTRUCTION PROJECT ADDENDA FOR STATE AGENCIES:</p> <p>(1) THE ARCHITECT/ENGINEER SHALL PREPARE THE ADDENDUM AND A LIST OF ALL PARTIES THAT HAVE PROCURED DRAWINGS AND SPECIFICATIONS FOR THE PROJECT. THE ADDENDUM AND LIST SHALL BE FORWARDED TO THE BUYER IN THE STATE PURCHASING DIVISION. THE ARCHITECT/ENGINEER SHALL ALSO SEND A COPY OF THE ADDENDUM TO THE STATE AGENCY FOR WHICH THE CONTRACT IS ISSUED.</p> <p>(2) THE BUYER SHALL SEND THE ADDENDUM TO ALL INTERESTED PARTIES AND, IF NECESSARY, EXTEND THE BID OPENING DATE. ANY ADDENDUM SHOULD BE RECEIVED BY THE BUYER WITHIN FOURTEEN (14) DAYS PRIOR TO THE BID OPENING DATE.</p> <p>(3) ALL ADDENDA SHOULD BE FORMALLY ACKNOWLEDGED BY ALL BIDDERS AND SUBMITTED TO THE STATE PURCHASING DIVISION. THE SAME RULES AND REGULATIONS THAT APPLY TO THE ORIGINAL BIDDING DOCUMENT SHALL ALSO APPLY TO AN ADDENDUM DOCUMENT. THE ONLY EXCEPTION MAY BE FOR AN ADDENDUM THAT IS ISSUED FOR THE SOLE PURPOSE OF CHANGING A BID OPENING TIME AND/OR DATE.</p> <p>REV. 11/96</p> <p>EXHIBIT 10</p> <p>DEP14906</p> <p>ADDENDUM ACKNOWLEDGEMENT</p> <p>I HEREBY ACKNOWLEDGE RECEIPT OF THE FOLLOWING CHECKED ADDENDUM(S) AND HAVE MADE THE NECESSARY REVISIONS TO MY PROPOSAL, PLANS AND/OR SPECIFICATION, ETC.</p>						

SEE REVERSE SIDE FOR TERMS AND CONDITIONS

SIGNATURE	TELEPHONE	DATE
TITLE	FEIN	ADDRESS CHANGES TO BE NOTED ABOVE

WHEN RESPONDING TO RFQ, INSERT NAME AND ADDRESS IN SPACE ABOVE LABELED 'VENDOR'



State of West Virginia  
 Department of Administration  
 Purchasing Division  
 2019 Washington Street East  
 Post Office Box 50130  
 Charleston, WV 25305-0130

# Request for Quotation

RFQ NUMBER  
**DEP14906**

PAGE  
**10**

ADDRESS CORRESPONDENCE TO ATTENTION OF  
**CHUCK BOWMAN**  
**304-558-2157**

**VENDOR**  
 \*B19160306      304-622-2400  
**PRO CONTRACTING INC**  
**PO BOX 2442**  
  
**CLARKSBURG WV 26301**

**SHIP TO**  
**ENVIRONMENTAL PROTECTION**  
**DEPT. OF**  
**OFFICE OF SPECIAL RECLAMATION**  
**105 S. RAILROAD STREET**  
**PHILIPPI, WV**  
**26416-9998      304-457-3219**

DATE PRINTED	TERMS OF SALE	SHIP VIA	F.O.B.	FREIGHT TERMS
02/17/2010				

BID OPENING DATE: **04/21/2010**      BID OPENING TIME **01:30PM**

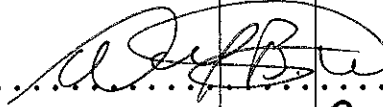
LINE	QUANTITY	UOP	CAT NO	ITEM NUMBER	UNIT PRICE	AMOUNT
ADDENDUM NOS.:						
NO. 1		✓		4-7-10		
NO. 2						
NO. 3						
NO. 4						
NO. 5						
I UNDERSTAND THAT FAILURE TO CONFIRM THE RECEIPT OF THE ADDENDUM(S) MAY BE CAUSE FOR REJECTION OF THE BIDS.						
VENDOR MUST CLEARLY UNDERSTAND THAT ANY VERBAL REPRESENTATION MADE OR ASSUMED TO BE MADE DURING ANY ORAL DISCUSSION HELD BETWEEN VENDOR'S REPRESENTATIVES AND ANY STATE PERSONNEL IS NOT BINDING. ONLY THE INFORMATION ISSUED IN WRITING AND ADDED TO THE SPECIFICATIONS BY AN OFFICIAL ADDENDUM IS BINDING.						
 .....SIGNATURE Pro Contracting, Inc. COMPANY .....DATE 4-20-10						
REV. 11/96						
NOTICE						
A SIGNED BID MUST BE SUBMITTED TO:						

SEE REVERSE SIDE FOR TERMS AND CONDITIONS		
SIGNATURE 	TELEPHONE 304-622-2400	DATE 4-20-10
TITLE Vice President	FEIN 26-3348227	ADDRESS CHANGES TO BE NOTED ABOVE

WHEN RESPONDING TO RFQ. INSERT NAME AND ADDRESS IN SPACE ABOVE LABELED 'VENDOR'



State of West Virginia  
 Department of Administration  
 Purchasing Division  
 2019 Washington Street East  
 Post Office Box 50130  
 Charleston, WV 25305-0130

# Request for Quotation

RFQ NUMBER  
**DEP14906**

PAGE  
**11**

ADDRESS CORRESPONDENCE TO ATTENTION OF  
**CHUCK BOWMAN**  
**304-558-2157**

**\*B19160306 304-622-2400**  
**PRO CONTRACTING INC**  
**PO BOX 2442**  
  
**CLARKSBURG WV 26301**

**ENVIRONMENTAL PROTECTION**  
**DEPT. OF**  
**OFFICE OF SPECIAL RECLAMATION**  
**105 S. RAILROAD STREET**  
**PHILIPPI, WV**  
**26416-9998 304-457-3219**

DATE PRINTED <b>02/17/2010</b>	TERMS OF SALE	SHIP VIA	F.O.B.	FREIGHT TERMS
-----------------------------------	---------------	----------	--------	---------------

BID OPENING DATE: **04/21/2010** BID OPENING TIME **01:30PM**

LINE	QUANTITY	UOP	CAT NO	ITEM NUMBER	UNIT PRICE	AMOUNT
<p>DEPARTMENT OF ADMINISTRATION            PURCHASING DIVISION            BUILDING 15            2019 WASHINGTON STREET, EAST            CHARLESTON, WV 25305-0130</p> <p>THE BID SHOULD CONTAIN THIS INFORMATION ON THE FACE OF THE ENVELOPE OR THE BID MAY NOT BE CONSIDERED:</p> <p>SEALED BID</p> <p>BUYER: CB-23</p> <p>REQ. NO.: DEP14906</p> <p>BID OPENING DATE: 04/21/2010</p> <p>BID OPENING TIME: 1:30 P.M.</p> <p>PLEASE PROVIDE A FAX NUMBER IN CASE IT IS NECESSARY TO CONTACT YOU REGARDING YOUR BID:            ----- <b>304 622-2410</b> -----</p> <p>PLEASE PRINT OR TYPE NAME OF PERSON TO CONTACT CONCERNING THIS QUOTE:            ----- <b>Steve Szabo</b> -----</p>						

SEE REVERSE SIDE FOR TERMS AND CONDITIONS

SIGNATURE <i>[Signature]</i>	TELEPHONE <b>304-622-2400</b>	DATE <b>4-20-10</b>
TITLE <b>Vice President</b>	FEIN <b>26-3348227</b>	ADDRESS CHANGES TO BE NOTED ABOVE

WHEN RESPONDING TO RFQ, INSERT NAME AND ADDRESS IN SPACE ABOVE LABELED 'VENDOR'

BUYER CB-23	PAGE	REQ. OR PO NO DEP 14906
SPENDING UNIT WEST VIRGINIA DEPARTMENT OF ENVIRONMENTAL PROTECTION/SPECIAL RECLAMATION		

WV-36a STATE OF WEST VIRGINIA  
REV. 5-26-09 PURCHASING CONTINUATION SHEET  
VENDOR:

### SCOPE OF WORK

The successful bidder shall provide appropriate equipment, materials, labor and any technical services needed for the successful reclamation of BUFFALO COAL COMPANY Permit S-2018-88, and any disturbance associated with such operation. The General Performance Standards (GPS) shall apply to all items in Scope of Work.

Work necessary on this site will include the following items, but is not limited to these:

1. Upon mobilization to the site, which will be directed in a written Notice to Proceed, the access roads shall be developed in accordance with bid item # 3.0. If, fuel and lubricants are to be stored on site, bid item # 2.0 shall be in place before fuel is delivered. Project sign is to be obtained and installed.
2. Storm water management in the form as described in bid item # 6.0 shall be installed (described locations)
3. Concurrent and continuous reclamation shall begin at point A as shown on the site plan and shall end at point B. Backfill is required for area OPEN PIT, per bid item 4.0. Regrading and topsoiling is required for all areas per bid item 5.0. Revegetation and soil improvements are required for ALL AREAS per bid item 7.0. Reclamation is to be according to the attached specifications, plans, and clarifying discussions at the Pre-Bid Conference
4. Construction stakeout as necessary to carry out work (no separate bid item)
5. Eliminate the open pit at the North end of the permit. The open pit will be eliminated by pumping, in an approved manner, all standing water. All water discharged from the open pit will meet technical based effluent limitations. Any fly ash found in the pit area will be spread on the exposed pit floor. Material to fill pit will be obtained from the spoil stockpile located above the permit and from already blasted material found on the right side of the open pit. The fill material will be graded to blend in with the existing contours on the right and left side of the pit. The cost of pumping, fly ash placement, spoil replacement, and regrading will be inclusive to the cost of open pit elimination (see attached specifications and/or plans).
6. Eliminate existing pond number five (#5) as shown on the attached plans. The pond will be eliminated by pumping, in an approved manner, all standing water. The water discharged from the pumping of the pond will meet technical based effluent limitations. The outer dike wall will be pulled in and the area regraded to fill the void left by the pond. The cost of the pumping, and regrading will be inclusive to the cost of the pond five elimination (see attached specifications and/or plans).
7. Clean and maintain pond number six (6) as a sediment control structure during the reclamation process. When 70% vegetative cover has been established on the reclaimed areas pond 6 will be eliminated. The pond will be eliminated by pumping, in an approved manner, all standing water. The water discharged from the pumping of the pond will meet technical based effluent limitations. The outer dike wall will be pulled in and the area regraded to fill the void left by the pond. The cost of the pumping, and regrading will be inclusive to the cost of the pond six elimination (see attached specifications and/or plans).
8. Install approximately fifteen hundred linear feet (1500LF) of haybale dike. The haybale dikes will be installed in three (3) five hundred linear foot (500LF) rows across the regraded open pit fill area as erosion controls. The cost of the haybale dikes will be inclusive to the cost of sediment control with haybale dikes (see attached plans and/or specifications).

BUYER CB-23	PAGE	REQ. OR PO NO DEP 14906
SPENDING UNIT WEST VIRGINIA DEPARTMENT OF ENVIRONMENTAL PROTECTION/SPECIAL RECLAMATION		

WV-36a STATE OF WEST VIRGINIA  
REV 5-26-09 PURCHASING CONTINUATION SHEET  
VENDOR:

9. Revegetate approximately ten (10) acres using the standard seed and fertilizer mixture. Apply agricultural lime at a rate of 3 tons per acre and incorporate into the soil prior to application of the seed fertilizer mixture. The cost of the lime seed, and fertilizer will be inclusive to the cost of revegetation (see attached plans and/or specifications).
10. Remove all structures and debris from site and dispose of properly. Receipts will be provided to the on-site DEP representative as proof of proper disposal.
11. Perform vegetative enhancement as needed on previously regraded and revegetated areas. All work for seed bed preparation will be inclusive to the cost of vegetative enhancement (see attached plans and/or specifications)

I, Stephen R. Nestor, the undersigned, hereby certify<sup>1</sup> that this Reclamation Plan is correct and shows to the best of my knowledge and belief all the information required by the surface mining laws of the State of West Virginia. The source of information was the approved mining and reclamation plan contained in the forfeited surface mine permit, existing site conditions and information contained in the WV DEP, Inspection and Enforcement files.

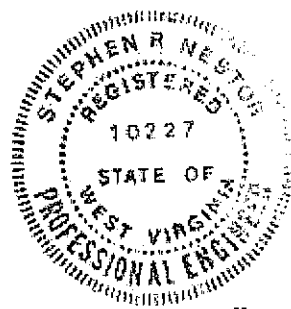

*Stephen R. Nestor*

Date: 12/23/09

Registered Professional Engineer WV No. 10227

<sup>1</sup> The term "certify" as used herein is defined as follows: An engineer's certification of conditions is a declaration of professional judgment. It does not constitute a warranty or guarantee, either expressed or implied.

PRO CONTRACTING, INC  
P.O. BOX 2442 / ARMORY RD.  
CLARKSBURG, WV 26302

BUYER CB-23	PAGE	REQ. OR PO NO DEP 14906
SPENDING UNIT WEST VIRGINIA DEPARTMENT OF ENVIRONMENTAL PROTECTION/SPECIAL RECLAMATION		

WV-36a STATE OF WEST VIRGINIA  
REV. 5-26-09 PURCHASING CONTINUATION SHEET  
VENDOR: -- --

ITEM NO.	QUANTITY	DESCRIPTION	UNIT PRICE	AMOUNT
		<b>BID SCHEDULE</b>		
		<b>PERMIT NAME: BUFFALO COAL COMPANY</b>		
		<b>PERMIT NUMBER: S-2018-88</b>		
The DEP reserves the right to request additional information and supporting documentation regarding unit prices when the unit price appears to be unreasonable.				
1 0	LUMP SUM	<b>MOBILIZATION/DEMobilIZATION/PROJECT SIGN</b> (5% of Total Bid maximum for this permit)	LUMP SUM	\$ 19,000. <sup>00</sup>
2 0	LUMP SUM	<b>SPILL CONTAINMENT AREA (S.C.A.)</b> (\$1,000 00 Maximum Bid for this permit)	LUMP SUM	\$ 1,000. <sup>00</sup>
3 0	2.800 LF	<b>HAULROAD/ACCESS ROAD UPGRADE</b>	\$ 7. <sup>00</sup> PER LF	\$ 19,600. <sup>00</sup>
4 0		<b><u>BACKFILLING</u></b>		
4 1	LUMP SUM	<b>OPEN PIT ELIMINATION</b>	LUMP SUM	\$ 247,500. <sup>00</sup>
4 2	LUMP SUM	<b>POND 5 ELIMINATION</b>	LUMP SUM	\$ 3,000. <sup>00</sup>
4 3	LUMP SUM	<b>POND 6 ELIMINATION</b>	LUMP SUM	\$ 8,000. <sup>00</sup>
5 0	LUMP SUM	<b>REGRADING AND TOPSOILING</b>	LUMP SUM	\$ 40,000. <sup>00</sup>
6 0	3.500 LF	<b>SEDIMENT CONTROL WITH SILT FENCE AND HAYBALE DIKE</b>	\$ 4. <sup>00</sup> PER LF	\$ 14,000. <sup>00</sup>
7 0		<b><u>REVEGETATION</u></b>		
7 1	10.0 AC	<b>AGRICULTURAL LIME</b>	\$ 500. <sup>00</sup> PER ACRE	\$ 5,000. <sup>00</sup>
7 2	10.0 AC	<b>FERTILIZER</b>	\$ 450. <sup>00</sup> PER ACRE	\$ 4,500. <sup>00</sup>
7 3	10.0 AC	<b>MULCH</b>	\$ 400. <sup>00</sup> PER ACRE	\$ 4,000. <sup>00</sup>

PRO CONTRACTING, INC  
P O. BOX 2442 / ARMORY RD.  
CLARKSBURG, WV 26302

BUYER CB-23	PAGE	REQ. OR PO NO. DEP 14906
SPENDING UNIT WEST VIRGINIA DEPARTMENT OF ENVIRONMENTAL PROTECTION/SPECIAL RECLAMATION		

WV-36a STATE OF WEST VIRGINIA  
REV. 5-26-09 PURCHASING CONTINUATION SHEET  
VENDOR:

ITEM NO.	QUANTITY	DESCRIPTION	UNIT PRICE	AMOUNT
74	10.0 AC	<u>VEGETATIVE SPECIES</u>	\$ 650. <sup>00</sup> PER ACRE	\$ 6,500. <sup>00</sup>
80	LUMP SUM	<u>STRUCTURE AND/OR DEBRIS REMOVAL</u>	LUMP SUM	\$ 10,000. <sup>00</sup>
90		<u>VEGETATIVE ENHANCEMENT</u>		
91	17.0 AC	<u>AGRICULTURAL LIME</u>	\$ 500. <sup>00</sup> PER ACRE	\$ 8,500. <sup>00</sup>
92	17.0 AC	<u>FERTILIZER</u>	\$ 450. <sup>00</sup> PER ACRE	\$ 7,650. <sup>00</sup>
93	17.0 AC	<u>VEGETATIVE SPECIES</u>	\$ 400. <sup>00</sup> PER ACRE	\$ 6,800. <sup>00</sup>
		<b>TOTAL PERMIT</b>		<b>\$ 405,050.<sup>00</sup></b>



BUYER CB-23	PAGE	REQ OR PO NO DEP 14906
SPENDING UNIT WEST VIRGINIA DEPARTMENT OF ENVIRONMENTAL PROTECTION/SPECIAL RECLAMATION		

WV-36a STATE OF WEST VIRGINIA  
REV. 5-26-09 PURCHASING CONTINUATION SHEET  
VENDOR:

## **BID ITEM TECHNICAL SPECIFICATIONS**

### **1.0 MOBILIZATION/DEMOBILIZATION/PROJECT SIGN**

#### **PROJECT SIGN**

A project sign shall be obtained or manufactured and installed as indicated on the attached specifications and details. Sign shall be installed prior to commencement of construction work. Payment for this sign shall be incidental to the mobilization item. No separate payment will be made.

#### **MOBILIZATION**

This work shall consist of the performance of construction preparatory operations, including the movement of personnel, equipment and other facilities to the project site, including the construction of all temporary access roads, necessary to begin work on a substantial phase of the Contract. The location of Contractor's office and operational areas shall be approved by Department of Environmental Protection (WVDEP).

This item shall also include the proper layout of the work by the Contractor, including furnishing, placing, and maintaining construction layout stakes necessary for the proper performance of the work under this contract, including borrow areas.

#### **DEMOBILIZATION**

Prior to demobilization, an inspection shall be conducted by the WVDEP and the Contractor to insure compliance with contract performance. Once compliance is ascertained, demobilization activities can be initiated and completed. Demobilization consists of the removal from the site of all equipment, supplies and personnel after completion of the work including cleanup of all rubbish and waste materials generated during the construction of this project and restoration of any damage to existing site improvements resulting from the Contractor's activities at the site. Project sign shall be left on-site after project completion. Demobilization shall be totally completed before the invoice for payment shall be processed.

#### **PAYMENT**

The lump sum bid for this item shall not exceed 5% of the total bid for this permit. Payment shall be made in two 50% amounts, one upon completion of the mobilization and project sign items and the second payment at the completion of demobilization. No deduction shall be made nor shall any increase be made in the lump sum item amount, regardless of decreases or increases in the final total Contract amount or any other reason.

### **2.0 SPILL CONTAINMENT AREA (S.C.A.)**

Spill containment measures shall be used for fuel and lubricant storage areas. All containers, barrels, buckets, cans, etc., are to be legally disposed of off-site at the expense of the Contractor. Used lubricants are to be disposed of according to state law to minimize pollution to the local surface and ground water supplies. Spills are the responsibility of the contractor and need immediate clean up and maintained at no expense to the State. This S.C.A. shall be constructed in accordance with the typical drawing specification (see attachment). Alternate containment measures will be considered for approval by the WVDEP designated onsite representative if acceptable results can be shown. Fuel tanks manufactured with secondary containment are desirable. Minimum secondary containment is 110 percent. (Bid limited to \$1,000.00 maximum)

BUYER CB-23	PAGE	REQ OR PO NO. DEP 14906
SPENDING UNIT WEST VIRGINIA DEPARTMENT OF ENVIRONMENTAL PROTECTION/SPECIAL RECLAMATION		

WV-36a STATE OF WEST VIRGINIA  
REV 5-26-09 PURCHASING CONTINUATION SHEET  
VENDOR:

### 3.0 HAULROAD/ACCESS ROAD UPGRADE

The contractor shall maintain and/or construct haulroad/access road(s) during the reclamation process to provide access on a well drained and stable surface. Plan to upgrade the existing access road to the specifications and details as indicated in the Upgrade Access Road drawing. The access road on the reclamation site shall be graded, sloped, and maintained to drain to provide a stable road surface free of excessive mud and standing waters at all times while work is in progress. Upon completion of all reclamation activities, a final three inch (3") layer of one and one-half inch (1½") crusher run limestone shall be placed on the roadway. Roads which are below the project shall be guarded against rolling rock and removal of rocks done as necessary. Dust control measures may be necessary if hauling creates airborne material. Snow and ice removal is to be included in this item.

### 4.0 BACKFILLING

Not a bid item, see items 4.1, 4.2, and 4.3.

#### 4.1 OPEN PIT ELIMINATION

Areas of this project subject to backfilling to achieve the post-mining land-use configuration shall be:

- a) Accomplished in a continuous concurrent manner on all surface disturbances within the original permit and associated disturbed areas as existing at bid showing;
- b) Utilize the best available non-toxic, non-acid producing spoil materials, as designated at bid showing;
- c) Be filled by mechanical methods to eliminate highwall and rock outcropping, to produce slopes of consistent lines and of the approximate original contour;
- d) Be free of protruding rock and debris; and,
- e) Be compacted in a progressive backfilling manner with mechanical equipment to ensure stability of backfill material.

The maximum acceptable slope ratio of any backfill face shall not exceed two (2) horizontal to one (1) vertical, unless otherwise stated. Backfilling and compaction activities shall cease during periods of adverse site conditions. (For example: excessive soil moisture.)

#### 4.2, 4.3 PONDS 5 AND 6 ELIMINATION

In addition to the requirements for eliminating the open pit area, elimination of all impounding structures shall also include:

- a) Dewatering of the impoundment by pumping to a location designated at bid showing;
- b) Removal of sediments to a designated drying/re-handling area on the permit area and within sediment control established for this project; and,
- c) Eliminating the pond structure by regrading the embankment and any added spoil materials to return the site to approximate original contour and/or generally conform the regraded area to the surrounding terrain.

### 5.0 REGRADEING AND TOPSOILING

Concurrent regrading and topsoiling shall immediately follow backfilling and shall distribute topsoil or the best available material to support vegetation, as identified by the WVDEP designated on-site representative, on the surface of the backfill in a smooth, uniform manner. This item shall include the elimination of all rills and gullies,

BUYER CB-23	PAGE	REQ OR PO NO DEP 14906
SPENDING UNIT WEST VIRGINIA DEPARTMENT OF ENVIRONMENTAL PROTECTION/SPECIAL RECLAMATION		

WV-36a STATE OF WEST VIRGINIA  
REV 5-26-09 PURCHASING CONTINUATION SHEET  
VENDOR:

the construction of sediment control sumps, the removal of sediment control sumps and the grading of spoil and/or fill materials and borrow areas

Final surface materials shall be free of all rock exceeding six (6) inches in diameter and shall be tracked, track to track. Topsoil presently stockpiled on site shall be preserved and spread on the final fill surface. In the absence of stockpiled topsoil, material which can be used as a topsoil substitute shall be identified, segregated, and stockpiled for spreading on the surface. If necessary to manufacture fines, mechanical treatment to pulverize the surface layer shall be required. Regrading and topsoiling shall be conducted prior to and in preparation for the Revegetation item.

### 6.0 SEDIMENT CONTROL WITH SILT FENCE AND HAYBALE DIKE

Disturbed areas which have storm water runoff and do not pass through a sediment control structure shall utilize the following Best Management Practice (BMP) methods to manage storm water runoff. For more information on BMP methods go to the WVDEP website <http://www.wvdep.org/dwwm/stormwater/BMP.htm> and click on **BMP Manual**. The WV Erosion and Sediment Control Best Management Practice Manual may be accessed or printed. This item has a Maximum Bid of \$5.00/LF of silt fence and hay bale material used on site.

1. Silt fence shall be utilized on perimeter barriers and shall be properly removed after permanent vegetation has been established, as directed by the WVDEP designated on-site representative. See attached drawing for further details.
2. For slope stability, place bales on the contour; at the top of cuts; and at the toe of slopes. Bales shall be placed in a row with ends tightly abutting the adjacent bales.
3. Bales shall be securely anchored in place by stakes or rebars driven through the bales. Rebar to be removed after permanent vegetation has been established, as directed by the WVDEP designated on-site representative. The first stake in each bale shall be driven toward previously laid bale to force the bales together. See attached drawing for further details.
4. Construction of sediment control sumps before culvert inlets and/or rock check dams in ditch lines may become necessary to supplement the silt fence and hay bale dikes. These items shall be installed upon request of the WVDEP designated onsite representative. Sumps and rock check dams shall be incidental to this bid item.

### 7.0 REVEGETATION

The actual seeding date, within the work performance period, shall be at the discretion of the Contractor, but a permanent vegetative cover must be established. Verification of materials used shall be required for payment. Seed bed preparation, unless otherwise approved, shall be conducted by industrial disks or tracking with heavy equipment with cleat marks across slope and parallel to the final contours. The surface shall be tracked, track to track. Seeding shall commence after seedbed preparation on a loose and uncompacted soil and with the approval of the WVDEP designated on-site representative. Contractor shall provide equipment as necessary to secure approval of the seedbed. Revegetation activities shall be carried out in a continuous, concurrent, timely and uniform manner. Failure to do this may result in nonpayment for portions of or the entire Revegetation item. Hydroseeding or broadcast seeding with the approved species is acceptable. The application rate may be increased but the ratio is to remain constant, however, no additional monetary compensation will be awarded. Areas outside the limits of

BUYER CB-23	PAGE	REQ OR PO NO DEP 14906
SPENDING UNIT WEST VIRGINIA DEPARTMENT OF ENVIRONMENTAL PROTECTION/SPECIAL RECLAMATION		

WV-36a STATE OF WEST VIRGINIA  
REV 5-26-09 PURCHASING CONTINUATION SHEET  
VENDOR:

construction, disturbed by the Contractor, shall be revegetated by the Contractor at no expense to WVDEP. Water utilized for hydroseeding shall be free of injurious or other toxic substances harmful to plant life. The source of water is subject to the approval of the WVDEP designated onsite representative. It shall be the Contractor's responsibility to repeat the procedures under REVEGETATION until a permanent vegetation cover is established. The acreage quantities in this contract are provided for bidding purposes only.

A Warranty Period of one (1) year shall commence upon completion and payment of the revegetation item of the Contract. No payment will be made for additional seeding necessary to comply with warranty requirements. The Warranty Period will be extended for one (1) year from the date of the last augmented seeding done by the Contractor. The performance bond and labor and materials bond shall remain in effect throughout the Warranty Period. The Standards for Evaluating Vegetative Cover as presented in Title 38, CSR2, Section 9 of the most current edition of the West Virginia Surface Mining Reclamation Regulations will apply.

Equipment for the retracking/scarification to eliminate rills and gullies shall be mobilized and utilized to produce slopes consistent with the regrading and topsoiling bid item prior to warranty reseeding. No additional payment will be made by WVDEP for this warranty work.

**MATERIALS REQUIRED:**

**7.1 AGRICULTURAL LIME**

Unless otherwise specified, all lime used for REVEGETATION shall be registered with the West Virginia Department of Agriculture, have an 85% minimum calcium carbonate equivalent, and meet the fineness classification no larger than that for ground lime. The following fineness classifications or combinations of lime are acceptable:

- Pulverized - 100% passing a U.S. Standard 20 mesh sieve
- 70% passing a U.S. Standard 100 mesh sieve
- Ground - 90% passing a U.S. Standard 20 mesh sieve
- 50% passing a U.S. Standard 60 mesh sieve
- 35% passing a U.S. Standard 100 mesh sieve

Use of blends and low-grade agricultural liming materials shall require prior approval. Lime shall be spread as soon as possible after delivery to site. Lime shall be applied evenly and uniformly distributed over the treated area. Lime shall be thoroughly mixed into the soil material. Lime subjected to adverse conditions before spreading will be deemed unacceptable. Failure to complete this phase shall result in nonpayment of this bid item.

Lime shall be applied at 3 tons/acre.

**7.2 FERTILIZER**

Fertilizer rates given for REVEGETATION are for 1,000 lbs. of 10-20-20 per acre. These rates are minimum and for bidding purposes.

Fertilizer shall be applied evenly and uniformly distributed over the treated area. Common complete fertilizers which meet the minimum standards are acceptable.

BUYER CB-23	PAGE	REQ OR PO NO. DEP 14906
SPENDING UNIT WEST VIRGINIA DEPARTMENT OF ENVIRONMENTAL PROTECTION/SPECIAL RECLAMATION		

WV-36a STATE OF WEST VIRGINIA  
REV. 5-26-09 PURCHASING CONTINUATION SHEET  
VENDOR:

### 7.3 MULCH

Acceptable mulch for this project is wood fiber, hay, or straw.

Mulch: Wood Fiber @ 1.0 ton/acre  
Hay or Straw: may be substituted at a rate of 2 tons/acre

### 7.4 VEGETATIVE SPECIES

Seeding rate required is for pure live seed (pls) in pounds per acre. The use of annuals or cover crops will not be considered for vegetative success.

#### SOUTH MIX

VEGETATIVE SPECIES <sup>1</sup>	RATE/ACRE <sup>1</sup>
Orchard Grass	@ 30 lbs/acre
Birdsfoot Trefoil <sup>2</sup>	@ 15 lbs/acre
Red Top	@ 10 lbs/acre
KY 31 Fescue	@ 10 lbs/acre
Perennial Ryegrass	@ 10 lbs/acre
Alsike Clover <sup>2</sup>	@ 5 lbs/acre
Black Locust <sup>3</sup>	@ 1 lbs/acre
Bicolor Lespedeza <sup>4</sup>	@ ¼ lbs/acre

- 1 Seeding rate required is for pure live seed in pounds (lbs) per acre
- 2 Herbaceous legumes must be treated with the appropriate bacterium before seeding
- 3 This species to be utilized only for 'Forestland' post-mining land-use.
- 4 This species to be utilized only for wildlife post-mining land projects

#### NORTH MIX

VEGETATIVE SPECIES <sup>1</sup>	RATE/ACRE <sup>1</sup>
Orchard Grass	@ 15 lbs/acre
Birdsfoot Trefoil <sup>2</sup>	@ 15 lbs/acre
Yellow Sweet Clover	@ 5 lbs/acre
Red Clover	@ 10 lbs/acre
Ky 31 Fescue	@ 15 lbs/acre
Foxtail Millet <sup>3</sup>	@ 12 lbs/acre
Wheat or Rye <sup>4</sup>	@ 50 lbs/acre
Black Locust <sup>5</sup>	@ 3 lbs/acre

- 1 Seeding rate suggested is for pure live seed (pls) in pounds (lbs) per acre
- 2 Herbaceous legumes must be treated with the appropriate bacterium before seeding.
- 3 Spring mix.
- 4 Fall mix.

BUYER CB-23	PAGE	REQ OR PO NO DEP 14906
SPENDING UNIT WEST VIRGINIA DEPARTMENT OF ENVIRONMENTAL PROTECTION/SPECIAL RECLAMATION		

WV-36a STATE OF WEST VIRGINIA  
REV. 5-26-09 PURCHASING CONTINUATION SHEET  
VENDOR:

<sup>5</sup> Black locust to be used only for 'Forestland' land use.

**80 STRUCTURE AND/OR DEBRIS REMOVAL**

All existing man-made items particular to the site and not to be utilized in the total reclamation of this site shall be demolished (if necessary) and disposed of in a legal manner. All iron, steel, aluminum, or any other metal, plastic, or any other man made material, including but not limited to I-Beams, Angle Iron, Channel Iron, Corrugated Metal, Flat Metal, Floc Drums, Grease Drums, Pipe or Conduit and all other debris is to be dismantled, removed and properly disposed of off-site and according to state, local, and federal requirements.

**90 VEGETATIVE ENHANCEMENT**

Areas which have been revegetated prior to this project, which are of a substandard vegetative stand, shall be enhanced during the active concurrent reclamation phase. Fertilization during the fall shall be accomplished prior to September 15 to ensure vegetation realizes the full benefit of the nutrients being applied before the advent of the dormant winter season. Seed shall be applied during spring and fall seeding periods only.

MATERIALS REQUIRED:

**91 AGRICULTURAL LIME**

Agricultural Lime - 3 tons/acre

**92 FERTILIZER**

Fertilizer 18-46-0 @ 300 lbs/acre

**93 VEGETATIVE SPECIES**

VEGETATIVE SPECIES <sup>1</sup>	RATE/ACRE
KY 31 Fescue	@ 5 lbs/acre
Birdsfoot Trefoil <sup>2</sup>	@ 5 lbs/acre
Red Clover <sup>2</sup>	@ 5 lbs/acre

<sup>1</sup> Seeding rate required is for pure live seed in pounds (lbs) per acre.

<sup>2</sup> Herbaceous legumes must be treated with the appropriate bacterium before seeding.

<sup>3</sup> Areas with poor vegetation will require scarification of the soil surface prior to top dressing with seed.

BUYER CB-23	PAGE	REQ OR PO NO DEP 14906
SPENDING UNIT WEST VIRGINIA DEPARTMENT OF ENVIRONMENTAL PROTECTION/SPECIAL RECLAMATION		

WV-36a STATE OF WEST VIRGINIA  
REV. 5-26-09 PURCHASING CONTINUATION SHEET  
VENDOR:

## **BID PREPARATION INFORMATION**

### **HISTORICAL INFORMATION**

Prospective bidders may review files at the West Virginia Department of Environmental Protection, 601 57<sup>th</sup> Street SE, Charleston, WV or the Regional West Virginia Department of Environmental Protection Office at 105 South Railroad St, Philippi, WV 26416. These files may contain additional information not included in the contract. Documents including, but not limited to, permit applications, permits, inspection reports, environmental documents, permit violation history, geological and geotechnical information, probable hydrologic consequences, maps, modifications, NPDES information and other related data. Copies may be obtained upon request and payment of copying fees.

### **EXAMINATION OF BID PACKAGE AND SITE OF WORK**

The bidder is required to examine, carefully, the bid package (plans, specifications, supplemental specifications, contract forms, etc) and the site of the work contemplated. The submission of a bid shall be considered prima facie evidence that the bidder has made such examination and has judged for and satisfied themselves as to the character, quantity, and quality of work to be performed and the materials required to be furnished under the Contract.

### **PREBID CONFERENCE**

Only the prospective bidders on the sign-in sheet in attendance for the entire Pre-Bid Conference will be eligible to submit bids for consideration of this project. Considerable foot travel over rough terrain and/or inclement weather may be required.

### **VIDEO**

The information given at the pre-bid showing by the project contact person or the assigned person shall be documented on video tape and shall be an integral part of this Contract's requirements, but will not supersede the written Contract. All information on video tape that is new or provides clarification to the Specifications, will be issued in writing by a formal addendum and will become part of the written Contract.

### **INTENT OF CONTRACT**

The intent of the Contract is for the reclamation/restoration of forfeited mine lands as required by West Virginia Department of Environmental Protection. The Contractor is to provide for the construction and completion in every detail of the work described. The Contractor shall furnish all labor, materials, equipment, tools, transportation, and supplies required to complete the work in accordance with the Plans, Specifications, and terms of the Contract.

Should any misunderstanding arise as to the intent or meaning of the Contract, or any discrepancy appear, the decision of the Director of Division of Land Restoration shall be final.

BUYER CB-23	PAGE	REQ. OR PO NO DEP 14906
SPENDING UNIT WEST VIRGINIA DEPARTMENT OF ENVIRONMENTAL PROTECTION/SPECIAL RECLAMATION		

WV-36a            STATE OF WEST VIRGINIA  
REV. 5-26-09    PURCHASING CONTINUATION SHEET  
VENDOR:

## GENERAL PERFORMANCE STANDARDS

### INTRODUCTION

The performance standards and non-compliance penalties which govern special reclamation-bond forfeiture projects are in Chapter 22A, Article 3, of the Code of West Virginia and subsequent rules and regulations. The following performance standards are of a general nature and do not represent all the performance standards applicable to a special reclamation-bond forfeiture project. However, some or all of these standards will pertain to each project

### BACKFILLING

- 1 Unless otherwise noted, the highwall shall be eliminated and the disturbed area graded to the approximate original contour
2. The material used to backfill and eliminate the highwall shall be sufficiently compacted so as to insure stability of the backfill throughout the warranty period.
- 3 The land above the highwall shall not be disturbed unless otherwise directed.
- 4 The best available material to support vegetation, sufficient to establish a permanent vegetative cover and to achieve the approved post mining land use, shall be used.

### BLASTING

The performance standards of the blasting regulations must be adhered to

### LIFE OF CONTRACT

The purchase order Contract becomes effective on the starting date as specified in the Notice to Proceed as issued by the Department of Environmental Protection (DEP). This Contract extends for a period of one (1) year and may be renewed until such "reasonable time" thereafter as is necessary to complete the payment therefore. A responsible Contractor's Agent shall be on the site at all working times who demonstrates a knowledge of mined land reclamation, contract requirements and responds to DEP (Owner) inspections.

### WORK PERFORMANCE PERIOD

The Work Performance Period is a defined portion of the Contract in which all items shall be completed. The Work Performance Period is to be performed within 365 calendar days of the Notice To Proceed. Extensions may be granted based upon Contractor's performance, weather conditions and site-specific site conditions.

### NOTICE TO PROCEED

A Notice to Proceed shall be issued to the Contractor by the project contact person for the Department of Environmental Protection. Actual construction may only begin after a Notice to Proceed is given and as specified. Such notice shall specify the starting date of the Purchase Order, the Work Performance Period, and the completion date of the Work Performance Period.



BUYER CB-23	PAGE	REQ OR PO NO DEP 14906
SPENDING UNIT WEST VIRGINIA DEPARTMENT OF ENVIRONMENTAL PROTECTION/SPECIAL RECLAMATION		

WV-36a STATE OF WEST VIRGINIA  
REV 5-26-09 PURCHASING CONTINUATION SHEET  
VENDOR: \_\_\_\_\_

---

### PRE-CONSTRUCTION CONFERENCE

The Contractor in possession of the awarded Purchase Order shall schedule a Pre-Construction Conference on the site within ten (10) days after receiving the Notice To Proceed. The Contractor's Agent (foreman or the on-the-ground supervisor) must be in attendance.

### GENERAL SUPERVISION

This Contract is under the general supervision of the West Virginia Department of Environmental Protection's contact person for the purpose of Contract compliance inspection only. Contractor shall supervise work being conducted at all times. All services rendered by the Engineer/Contact Person consist of professional opinions and recommendations made in accordance with generally accepted engineering practice. Under no circumstances is it the intent of the Engineer/Contact Person to directly control the physical activities of the Contractor or the Contractor's workmen's accomplishment of work on this project.

### CONTRACTOR RESPONSIBILITY

The Contractor is responsible for compliance with all aspects of this written Contract. No changes will be honored without prior approval from the Program Supervisor.

### LAWS TO BE OBSERVED

The Contractor shall keep fully informed of all Federal and State laws, all local laws, ordinances, and regulations and all orders and decrees of bodies or tribunals having any jurisdiction or authority, which in any manner affect those engaged or employed on the work, or which in any way affect the conduct of the work. The Contractor shall at all times observe and comply with all such laws, ordinances, regulations, orders and decrees; and shall protect and indemnify the State and its representatives against any claim or liability arising from or based on the violation of any such laws, ordinances, regulations, orders, or decrees, whether by themselves, their subcontractors or their employees.

### PERMITS, LICENSES AND TAXES

The Contractor shall procure all permits and licenses, pay all charges, fees, and taxes, and give all notices necessary and incidental to the due and lawful prosecution of the work.

### CONCURRENT RECLAMATION

Reclamation of this project shall commence at a definite point as defined and shall progress from that point with total reclamation to include backfilling, grading/regrading, and revegetation. Changes may be granted based upon weather or differing site conditions with prior approval.

### WATER QUALITY CONTROL

Water quality control shall commence with initial start-up of the project and remain in effect for the extent of the backfilling, regrading and revegetation activity. DEP obtains a storm water permit for each project from the Water Resources Division (General Water Pollution Control Permit WVO115924). The Contractor is responsible

BUYER CB-23	PAGE	REQ OR PO NO. DEP 14906
SPENDING UNIT WEST VIRGINIA DEPARTMENT OF ENVIRONMENTAL PROTECTION/SPECIAL RECLAMATION		

WV-36a STATE OF WEST VIRGINIA  
REV 5-26-09 PURCHASING CONTINUATION SHEET  
VENDOR:

for performing the best management practices Adequate facilities shall be installed, operated and maintained using the best management practices of the U S. Environmental Protection Agency's Non-Point Source (NPS) Program for sediment control during the active reclamation. The Contractor shall take any and all steps necessary to prevent erosion or silting problems from occurring and to minimize pollution or sedimentation of the stream. If any such problems develop, the contractor shall be responsible to take immediate corrective action. No separate payment for this work will be honored. All impounded waters which require removal during reclamation shall be pumped with appropriate measures taken to prevent erosion from the discharge. The Contractor shall be responsible for treatment of said waters to meet pH standards. The water shall be discharged only when the quality meets a pH equivalent to the pH of the receiving stream but not less than 6.0.

### **DIFFERING SITE CONDITIONS**

During the progress of the work, if subsurface or latent physical conditions are encountered at the site differing materially from those indicated in the contract or if unknown physical conditions of an unusual nature, differing materially from those ordinarily encountered and generally recognized as inherent in the work provided by the Contract, are encountered at the site, the party discovering such conditions shall promptly notify the other party in writing of the specific differing conditions before they are disturbed and before the affected work is performed

Upon written notification, the Engineer/Contact Person will investigate the conditions, and if determined that the conditions materially differ and cause an increase or decrease in the cost or time required for the performance of any work under the contract, an adjustment, excluding loss of anticipated profits, will be made and the Contract modified in writing accordingly. The Engineer/Contact Person will notify the Contractor of DEP's determination whether or not an adjustment of the Contract is warranted.

No Contract adjustment which results in a benefit to the Contractor will be allowed unless the Contractor has provided the required written notice.

No Contract adjustment will be allowed under this clause for any effects caused on unchanged work.

### **HANDLING AND STORAGE OF MATERIALS**

Materials which are stored on site, before utilization, shall be stored so as to assure the preservation of their quality and fitness for the work. Stored materials, even though approved before storage, may be inspected again prior to their use in the work. Damaged or deteriorated materials shall be removed and replaced by materials meeting the original specifications.

Aggregate stockpiles shall be made on ground that is denuded of vegetation, hard, and well drained. Addition and removal of aggregate from the stockpile shall be done in a manner which will not result in the inclusion of foreign material into the aggregate or result in the separation of sizes. The use of the aggregate will determine if exceptions are permitted.

All materials shall be handled in such a manner as to preserve their quality and fitness for the work.

### **MAINTENANCE DURING CONSTRUCTION**

The Contractor shall maintain the work during construction and until the project is accepted. All cost of maintenance work during construction and before the project is accepted shall be included in the unit or lump sum prices on the various pay items.

### **FINAL INSPECTION**

A final inspection meeting by the Department of Environmental Protection's Specialist and the Contractor

BUYER CB-23	PAGE	REQ OR PO NO DEP 14906
SPENDING UNIT WEST VIRGINIA DEPARTMENT OF ENVIRONMENTAL PROTECTION/SPECIAL RECLAMATION		

WV-36a STATE OF WEST VIRGINIA  
REV. 5-26-09 PURCHASING CONTINUATION SHEET  
VENDOR:

is required for the construction phase and prior to Demobilization.

### ACREAGE QUANTITIES

The acreage quantities in this Contract are for bidding purposes only and are a set (definite) number for the project area as specified at the pre-bid showing. Only surveyed acreage's through figures the Contractor and/or the State develops will be honored to alter these acreage numbers. No separate payment will be made for surveying.

### PAYMENT

Invoices must be submitted on prescribed Department of Environmental Protection, Special Reclamation Program forms and include verification. Certified contractor payrolls for operators directly involved in this project and a current workers compensation certificate must accompany each invoice for payment. Verification of wage rates may include employee interviews. Invoices shall be signed in blue ink so that it is easy to verify that document is an original. Vendor should submit with their bid the current remit-to address to be used for payment processing.

MOBILIZATION/DEMOBILIZATION shall be invoiced at fifty percent (50%) with the first invoice and the last 50% invoiced after Demobilization and acceptance of the road abandonment or final invoice. Demobilization must have written approval.

SPILL CONTAINMENT AREA shall not exceed \$1,000.00 and will be payable in two payments. The first fifty percent (50%) payable with the first invoice and the remainder payable when all fuel tanks, containers, etc., including any spillage, are removed from the site.

Lump sum items shall be percentage payments based on work completed at time of invoice and paid upon acceptance by the Department of Environmental Protection.

Unit items shall be invoiced by specified units completed and accepted by the DEP.

ROAD ABANDONMENT shall be included in the final construction invoice.

### FAILURE TO COMPLETE ON TIME AND LIQUIDATED DAMAGES

Time is an essential element of the Contract and it is important that the work be completed within the time specified. The cost to the Department of the administration of the Contract, including engineering, inspection and supervision, will increase as the time required to complete the work is increased.

The Work Performance Period as specified in the Contract's Notice to Proceed shall be complied with or result in liquidated damages. Such damages shall be assessed at an amount of two hundred and fifty dollars (\$250.00) per day for each and every day beyond the Work Performance Period as specified in the Notice to Proceed. The total amount of daily charges will be deducted from any moneys due the Contractor, not as a penalty but as liquidated damages.

### REVEGETATION AND WARRANTY

The seeding date shall be at the discretion of the Contractor once an approved seedbed has been prepared. In all cases a permanent vegetative cover capable of supporting the post-mining land use must be established. A Warranty Period of one (1) year shall commence upon completion and payment of the Revegetation item of the Contract. No payment will be made for additional seeding necessary to comply with warranty requirements. The Warranty Period will be extended for one (1) year from the date of the last augmented seeding done by the

BUYER CB-23	PAGE	REQ OR PO NO. DEP 14906
SPENDING UNIT WEST VIRGINIA DEPARTMENT OF ENVIRONMENTAL PROTECTION/SPECIAL RECLAMATION		

WV-36a STATE OF WEST VIRGINIA  
REV. 5-26-09 PURCHASING CONTINUATION SHEET  
VENDOR:

Contractor: The performance bond and labor and materials bond shall remain in effect throughout the Warranty Period. The Standards for Evaluating Vegetative Cover as presented in Title 38, CSR2, Section 9 of the West Virginia Surface Mining Reclamation Regulations will apply.

Equipment for the retracking/scarification to eliminate rills and gullies shall be mobilized and utilized to produce slopes consistent with the regrading and topsoiling bid item prior to warranty reseeding. No additional payment will be made by DEP for this warranty work.

Water utilized for hydroseeding shall be free of injurious or other toxic substances harmful to plant life. The source of water is subject to the approval of the DEP contact person.

### CONTRACT NON-COMPLIANCE

If in the opinion of the Department of Environmental Protection the Contract is not in compliance with any line item specification, that portion of the project shall cease until a compliance schedule and understanding is demonstrated in writing and accepted by the Director of Division of Land Restoration.

### CONTRACT DELETIONS

Any line item, or any portion thereof, may be deleted when determined by the DEP project contact person that such line item, or portion thereof, is deemed unnecessary for the successful reclamation of this project. No claim for loss of anticipated profits will be considered.

### CANCELLATION

The performance of work under Contract may be terminated by the DEP in whole, or from time to time in part whenever the State shall determine that such termination is in the best interest of the State. Any such termination shall be effected by delivery to the Contractor of a Notice of Termination specifying the extent to which performance of work under the Contract is terminated and the date upon which such termination becomes effective.

When contracts, or any portion thereof, are terminated before completion of all items of work in the Contract, payment will be made for the actual number of units or items of work completed and accepted at the Contract unit price. No claim for loss of anticipated profits will be considered. Reimbursement for organization of the work, when not otherwise included in the Contract, and moving equipment to and from the job will be considered where the volume of work completed and accepted is too small to compensate the Contractor for these expenses under the Contract unit prices, the intent being that an equitable settlement will be made with the Contractor.

Termination of the Contract or a portion thereof shall not relieve the Contractor of his responsibilities for the completed work, nor shall it relieve his surety of its obligation for and concerning any just claims arising out of the work performed.

This Contract may be cancelled in whole or in part in writing by the Director of Purchasing, without prejudice to any other right or remedy it may have, provided that the Contractor is given not less than thirty (30) calendar days written notice, (delivered by certified mail, return receipt requested) of intent to terminate. This Contract objective is to comply with the reclamation laws of this state and must be expedient to meet the time requirements for reclamation of revoked surface mine permits.

BUYER CB-23	PAGE	REQ OR PO NO. DEP 14906
SPENDING UNIT WEST VIRGINIA DEPARTMENT OF ENVIRONMENTAL PROTECTION/SPECIAL RECLAMATION		

WV-36a STATE OF WEST VIRGINIA  
 REV. 5-26-09 PURCHASING CONTINUATION SHEET  
 VENDOR:

S

Attn:

A

Re: Notice to Proceed  
 Permit Name: \_\_\_\_\_  
 Permit No: \_\_\_\_\_  
 Purchase Order No : DEP

Dear :

M

The purpose of this letter is to express our appreciation for your work in advance and to recognize a reclamation partnership project. The official starting date for the above mentioned purchase order is . The work performance period must be completed by . The contract life of one year is provided to accomplish all line items and to process all payments within that period.

You must schedule a pre-construction conference on site within ten (10) days after receiving this Notice to Proceed. It is then mandatory that construction begins within ten (10) days of the pre-construction conference and continues diligently until completion of the project. Please contact this office to schedule the pre-construction conference. The foreman, superintendent, or on-the-ground supervisor must be in attendance at this conference.

P

Failure to comply with this Notice to Proceed will cause termination of the Contract and forfeiture of your performance bond.

If you have any questions please feel free to contact this office

L

Sincerely,

E

BUYER CB-23	PAGE	REQ. OR PO NO. DEP 14906
SPENDING UNIT WEST VIRGINIA DEPARTMENT OF ENVIRONMENTAL PROTECTION/SPECIAL RECLAMATION		

WV-36a STATE OF WEST VIRGINIA  
REV. 5-26-09 PURCHASING CONTINUATION SHEET  
VENDOR:

## PROJECT CONSTRUCTION SIGN

### WORK REQUIRED

The work to be performed under this Section consists of providing all labor, material and equipment necessary to install a project sign as indicated on the detail included herein and as specified herein

### MATERIALS

Paint. Paint for the project sign shall be one (1) coat Exterior-Grade Wood Primer- Sealer, and two (2) coats Exterior-Grade Enamel by Glidden or equivalent.

Wood. Sign face shall be 3/4" X 4' X 8' Marine Exterior plywood, and posts and cross braces shall be treated

Hardware. All hardware shall be manufactured from good, commercial-quality material and be rust resistant such as galvanized coated

### EXECUTION

#### PROJECT SIGN

The signboard shall be cut to the dimensions shown on the details herein. The sign shall be painted with one (1) coat of primer and two (2) coats of white enamel. All exterior cut edges shall be smooth sanded prior to painting. All edges shall be double primed. The letters, border and strips shall be painted as shown on the detail drawing.

The Contractor shall bolt the sign to posts and provide required cross bracing. The posts and sign shall be erected and posts set in gravel base, as shown on the drawings. One (1) sign is required and is to be located at the direction of WVDEP.

#### PAYMENT

Payment for the work which shall include installation of the project sign shall be incidental to the lump sum bid item for "Mobilization/Demobilization"

#### NOTE

No construction work shall commence prior to the project sign being installed

BUYER CB-23	PAGE	REQ. OR PO NO. DEP 14906
SPENDING UNIT WEST VIRGINIA DEPARTMENT OF ENVIRONMENTAL PROTECTION/OFFICE OF SPECIAL RECLAMATION		



**Joe Manchin, III,**  
Governor



Randy C Huffman,  
Cabinet Secretary



Ken Ellison,  
Director

**STATE OF WEST VIRGINIA  
DEPARTMENT OF ENVIRONMENTAL PROTECTION**

**Division of Land Restoration  
Office of Special Reclamation**

Project Cost: \$XXX,XXX.00  
Funding provided by the Special Reclamation Coal Tax paid by WV Coal Mine Companies

Permit Name Permit Number	Project Start Date: 01/01/01
------------------------------	------------------------------

Contractor: Joe Smith Contracting

BUYER CB-23	PAGE	REQ. OR FO NO. DEP 14906
SPENDING UNIT		
WEST VIRGINIA DEPARTMENT OF ENVIRONMENTAL PROTECTION/OFFICE OF SPECIAL RECLAMATION		

77 1/4"

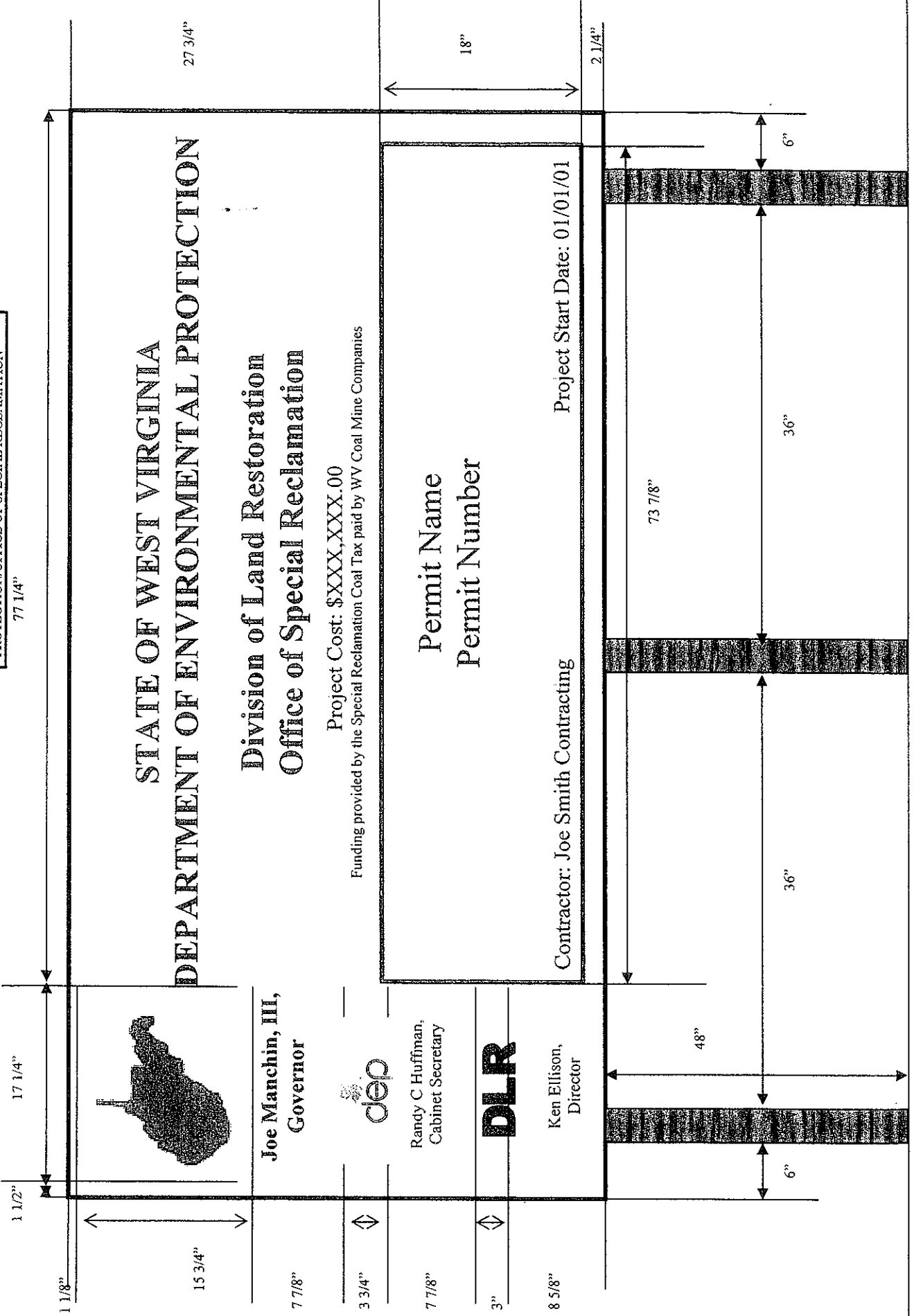

**STATE OF WEST VIRGINIA**  
**DEPARTMENT OF ENVIRONMENTAL PROTECTION**

**Division of Land Restoration**  
**Office of Special Reclamation**

Project Cost: \$XXX,XXX.00  
Funding provided by the Special Reclamation Coal Tax paid by WV Coal Mine Companies

Permit Name  
Permit Number

Contractor: Joe Smith Contracting  
Project Start Date: 01/01/01



**Joe Manchin, III,**  
Governor

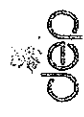

Randy C Huffman,  
Cabinet Secretary



Ken Ellison,  
Director



BUYER CB-23	PAGE	REQ. OR FO NO. DEP14906
SPENDING UNIT WEST VIRGINIA DEPARTMENT OF ENVIRONMENTAL PROTECTION/OFFICE OF SPECIAL RECLAMATION		

96



Joe Manchin, III,  
Governor

48"

# STATE OF WEST VIRGINIA DEPARTMENT OF ENVIRONMENTAL PROTECTION

## Division of Land Restoration Office of Special Reclamation

Project Cost: \$XXX,XXX.00

Funding provided by the Special Reclamation Coal Tax paid by WV Coal Mine Companies



Randy C Huffman,  
Cabinet Secretary



Ken Ellison,  
Director

Permit Name	Project Start Date: 01/01/01
Permit Number	
Contractor: Joe Smith Contracting	

7 7/8"

9 3/8"

81 3/8"

5 1/4"

BUYER CB-23	PAGE	REQ. OR PO NO. DEP14906
SPENDING UNIT WEST VIRGINIA DEPARTMENT OF ENVIRONMENTAL PROTECTION/OFFICE OF SPECIAL RECLAMATION		



**Joe Manchin, III,**  
Governor

**dep**

**Randy C. Huffman,**  
Cabinet Secretary

**DLR**  
Ken Ellison,  
Director

**STATE OF WEST VIRGINIA**

**DEPARTMENT OF ENVIRONMENTAL PROTECTION**

**Division of Land Restoration**

**Office of Special Reclamation**

Project Cost: \$XXX,XXX.00

Funding provided by the Special Reclamation Coal Tax paid by WV Coal Mine Companies

Permit Name

Permit Number

Contractor: Joe Smith Contracting      Project Start Date: 01/01/01

17 1/2"

1 1/2"

3/4"

1 1/4"

9 1/4"

1"

3/4"

1"

8"

1"

3/4"

1"

3 3/4"

6"

2 1/4"

1 1/4"

2 1/4"

3 3/4"

2 1/4"

1 1/4"

2 1/4"

3 3/4"

1 1/4"

4 7/8"

2 1/4"

1 1/4"

2 1/4"

4 7/8"

1 1/4"

3 3/4"

BUYER CB-23	PAGE	REQ. OR PO NO. DEP 14906
SPENDING UNIT WEST VIRGINIA DEPARTMENT OF ENVIRONMENTAL PROTECTION/OFFICE OF SPECIAL RECLAMATION		

Notes:

1. Sign Board to be 3/4" by 4' X 8' Marine Plywood
2. Sign Board Color is to be White and Letter Colors are to be Dark Green
3. 2" X 4" Treated Cross Brace Let into Posts
4. Mount sign to Posts using 3/8" X 5" Galvanized Carriage Bolts
5. Posts are to be Treated 4" X 4" X 12'
6. Location determined WVDEP

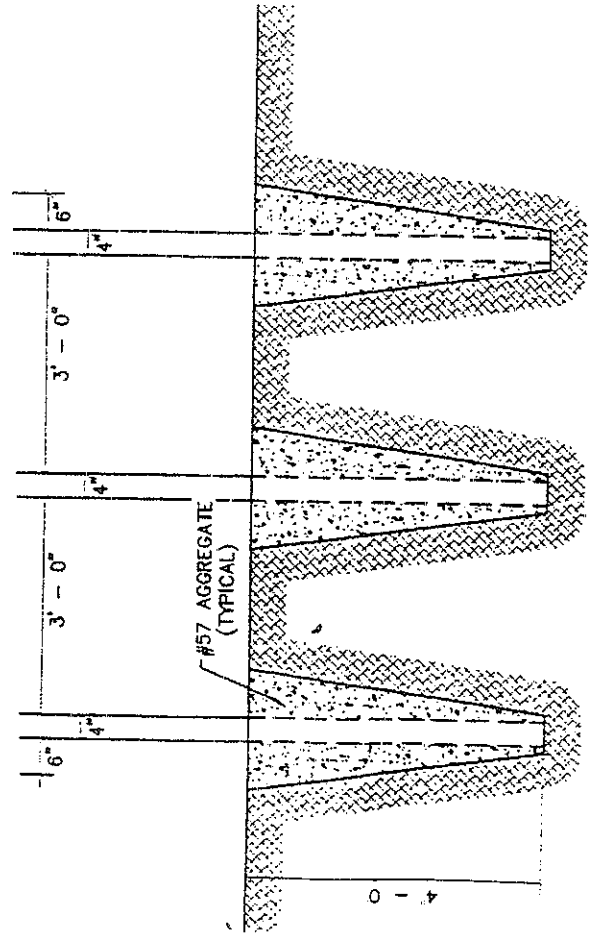
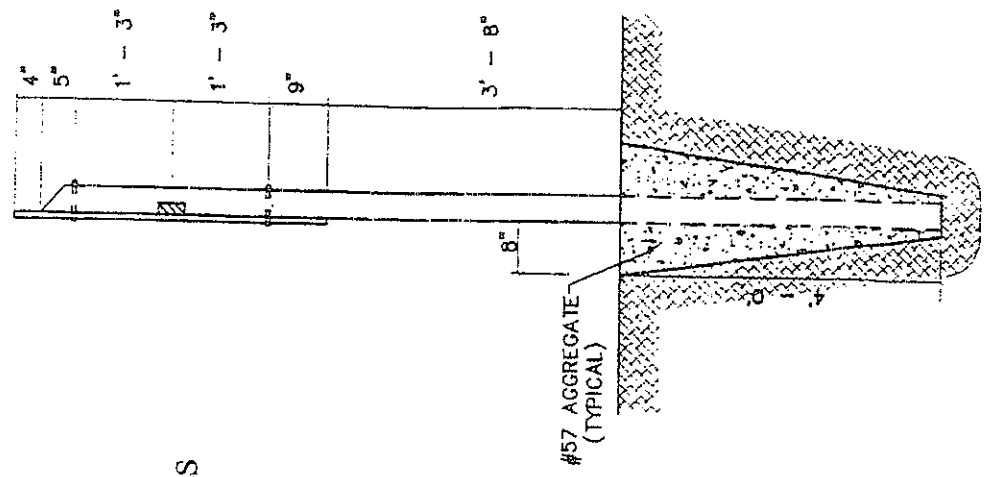

BUYER CB-23	PAGE	REQ OR PD NO DEP 14906
SPENDING UNIT WEST VIRGINIA DEPARTMENT OF ENVIRONMENTAL PROTECTION/OFFICE OF SPECIAL RECLAMATION		

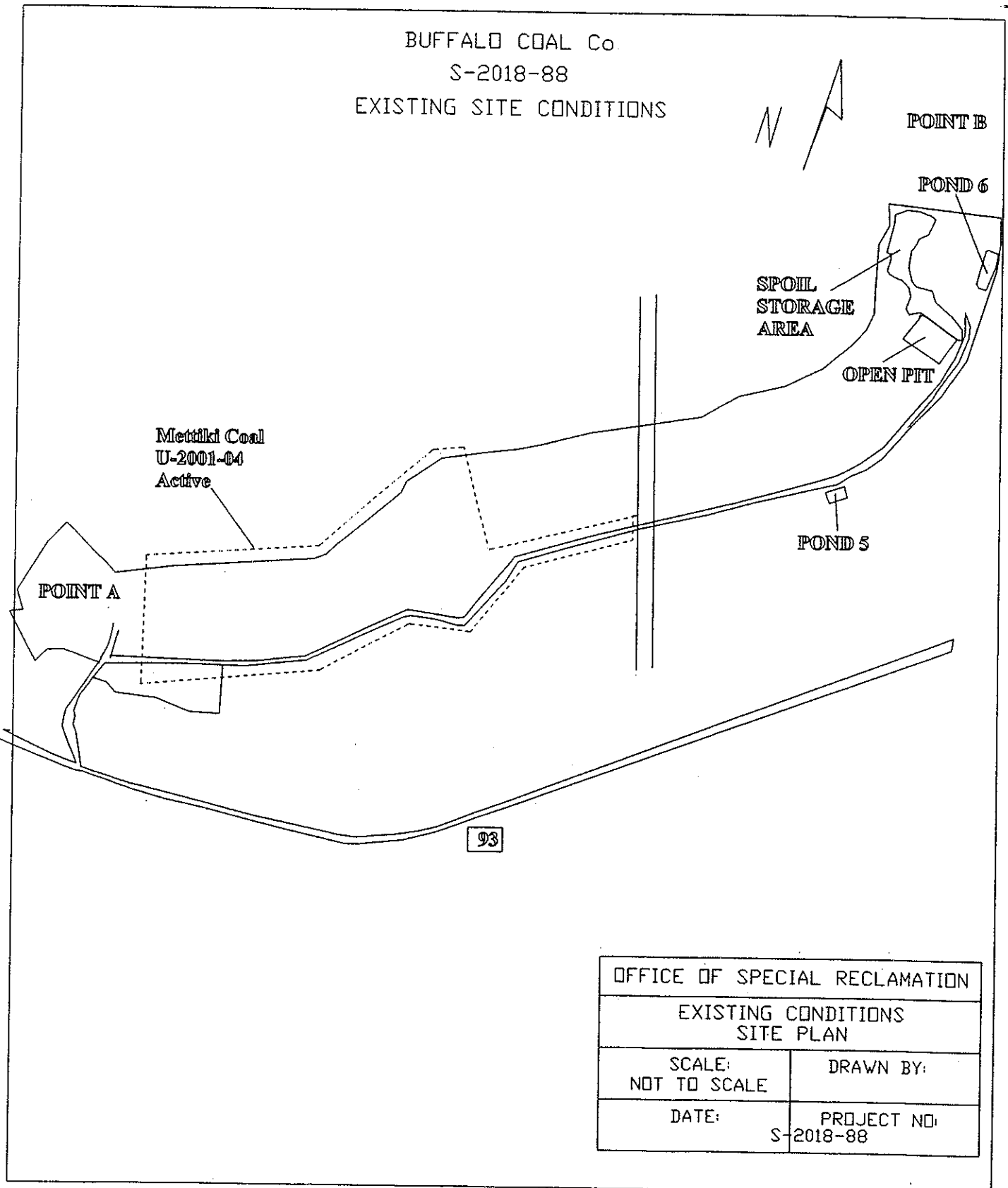

OFFICE OF SPECIAL RECLAMATION	
EXISTING CONDITIONS SITE PLAN	
SCALE: NOT TO SCALE	DRAWN BY:
DATE:	PROJECT NO: S-2018-88

WV-36a STATE OF WEST VIRGINIA  
REV. 1/29/02 PURCHASING CONTINUATION SHEET  
VENDOR:

BUYER CB-23	PAGE	REQ_OR_PD_NO DEP 14906
SPENDING UNIT WEST VIRGINIA DEPARTMENT OF ENVIRONMENTAL PROTECTION/OFFICE OF SPECIAL RECLAMATION		

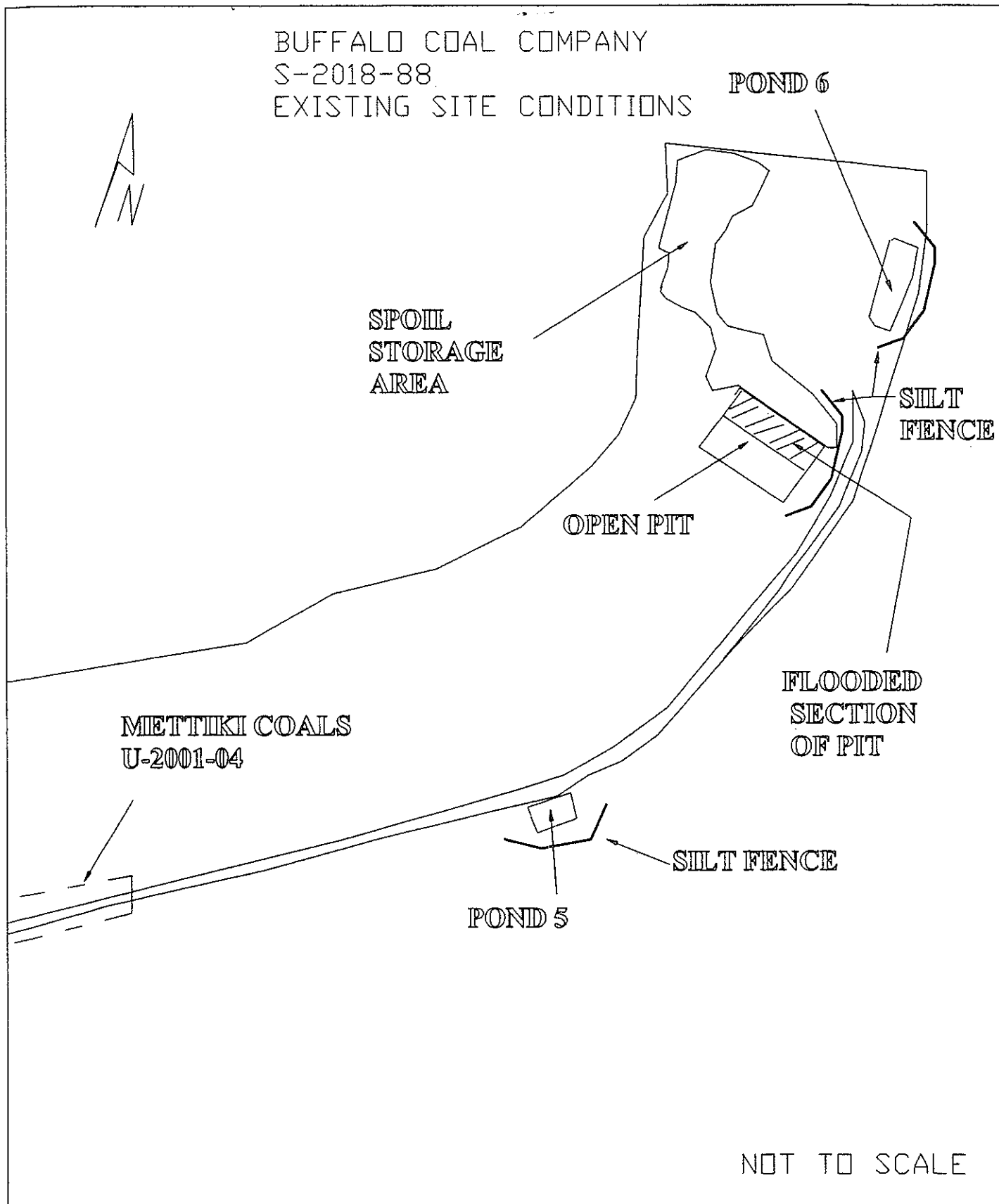

SPILL CONTAINMENT

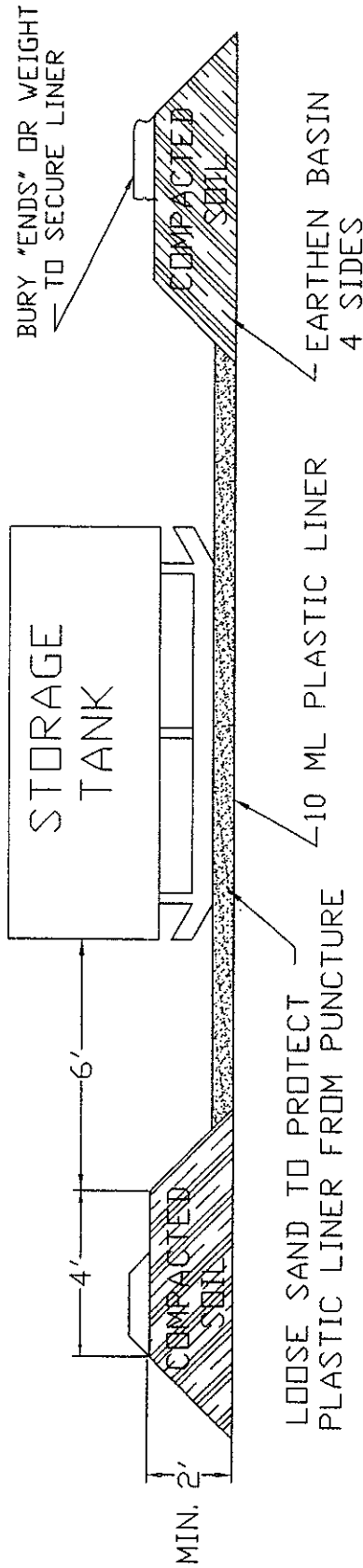

SELECTED HEIGHT OF EARTHEN BERM IS TO BE A TWO (2') FOOT MINIMUM OR ONE HUNDRED TEN PERCENT (110%) OF THE CAPACITY OF THE TANK(S) TOTAL VOLUME WITHIN THE BERM. A SIX INCH (6") FREEBOARD MUST BE INCLUDED.

NOTE: A TWO INCH (2") WATER REMOVAL DRAIN SHALL BE LOCATED AT THE LOWEST POINT IN THE BOTTOM OF THE CONTAINMENT VOLUME. IT SHALL CONNECT TO A NORMALLY CLOSED VALVE OUTSIDE THE DIKE. THE VALVE SHALL BE MANUALLY OPERATED AND PROTECTED FROM UNAUTHORIZED OPERATION. RAINWATER CONTAINED WITHIN THIS DIKE SHALL BE EXAMINED PRIOR TO RELEASE TO ENSURE THAT HARMFUL QUANTITIES OF FUELS AND LUBRICANTS ARE NOT DISCHARGED. ALTERNATE METHODS OF WATER REMOVAL WILL BE CONSIDERED FOR APPROVAL.

TANKS WITH SECONDARY CONTAINMENT MAY BE USED AS AN ALTERNATIVE.

# ACCESS ROAD UPGRADE BUFFALO COALS S-2018-88

BUYER CB-23	PAGE	REQ. or P.O. No. DEP 14906
ACCESS ROAD UPGRADE		

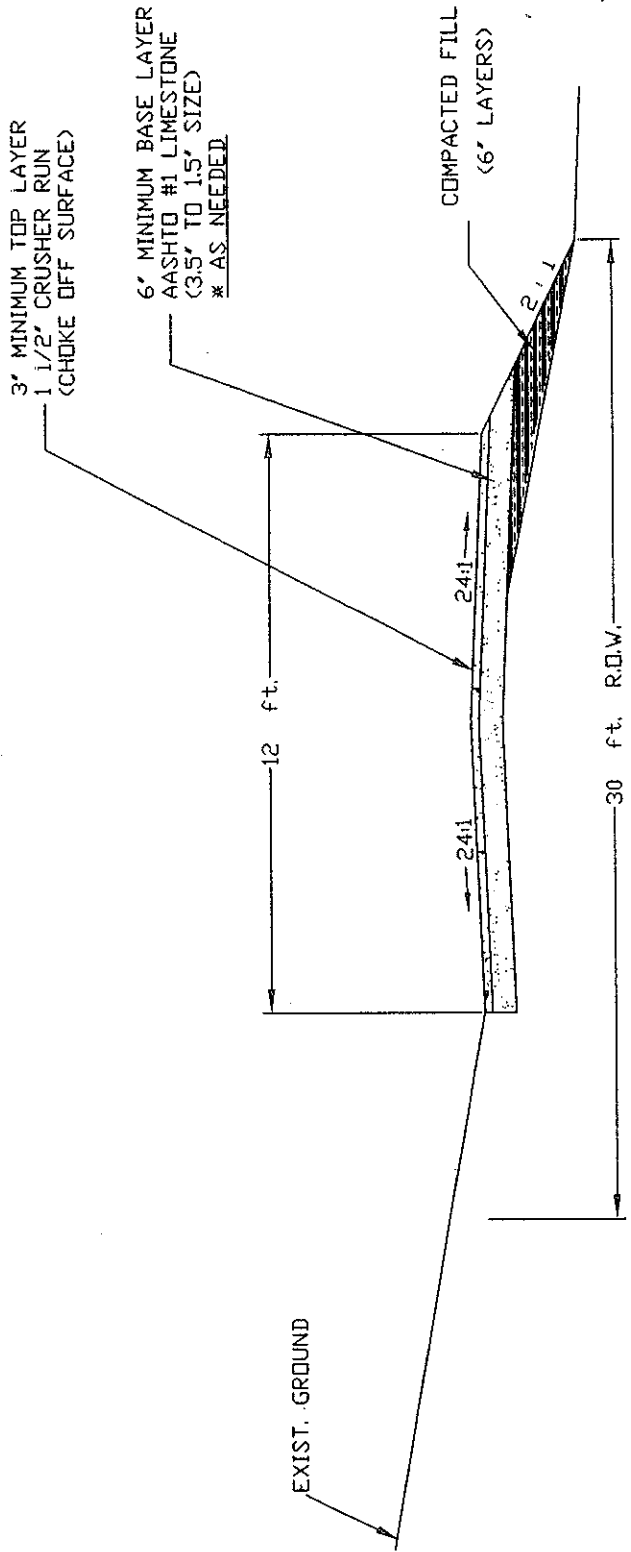

## TYPICAL SECTION

- NOTES:** THE EXISTING ROAD SHALL BE REGRADED, SHAPED, AND ROCKED AS NECESSARY TO MEET THESE SPECIFICATIONS.
- ANY TREES OR BRUSH WITHIN THE 30 FEET R.O.W. OF THE ROAD SHALL BE REMOVED.
- ANY OVERHANGING TREE LIMBS IN THE R.O.W. AT A HEIGHT OF 15 FEET OR LESS SHALL BE REMOVED.

BUYER CB-23	PAGE 1	REQ DR PG NO DEP 14906
SPENDING UNIT WEST VIRGINIA DEPARTMENT OF ENVIRONMENTAL PROTECTION OFFICE OF SPECIAL RECLAMATION		

BUFFALO COAL Co.  
 S-2018-88  
 POND 5 ELIMINATION TYPICAL

POND 5 CROSS SECTION PRIOR to ELIMINATION

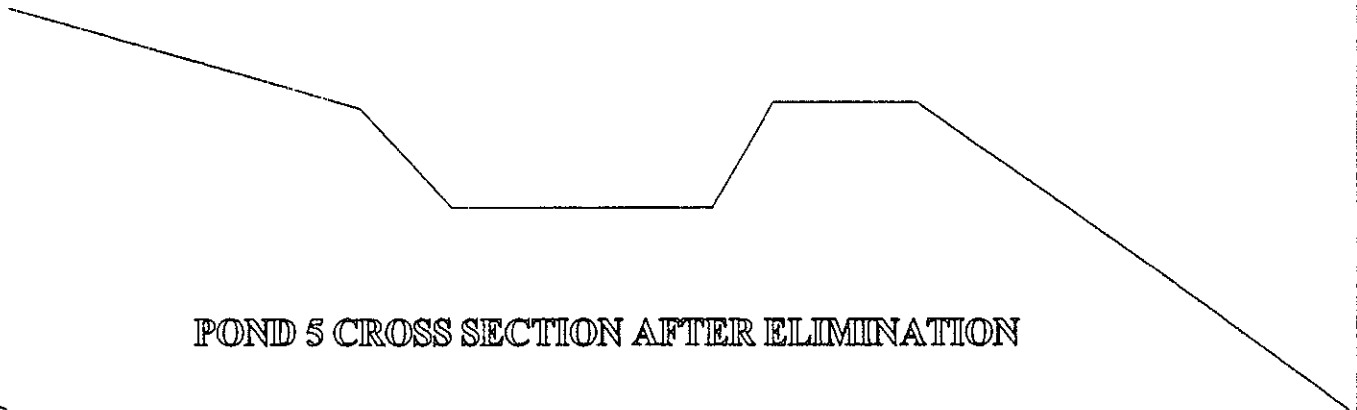

POND 5 CROSS SECTION AFTER ELIMINATION

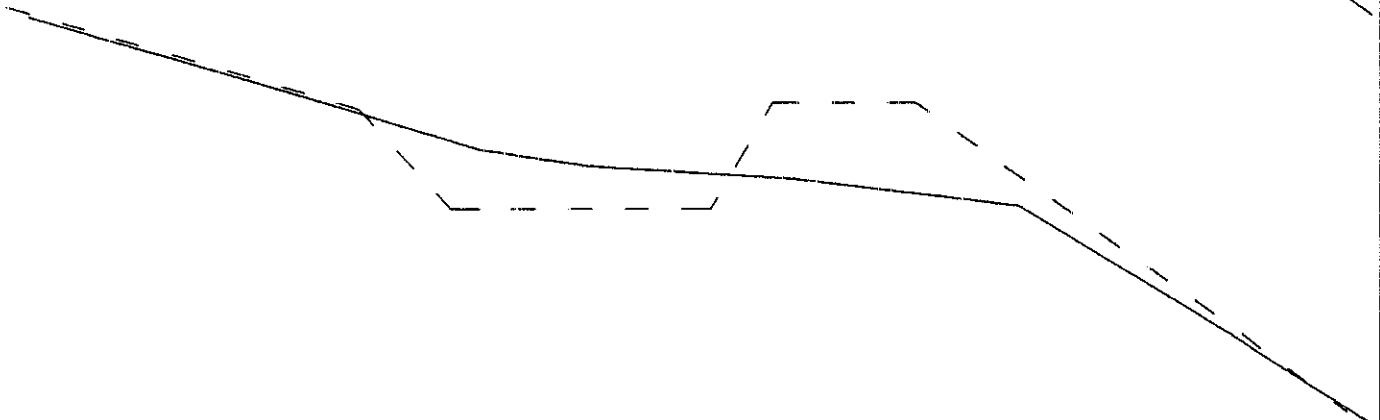

OFFICE OF SPECIAL RECLAMATION	
POND 5 ELIMINATION TYPICAL	
SCALE: NOT TO SCALE	DRAWN BY:
DATE:	PROJECT NO: S-2018-88



WV-36a STATE OF WEST VIRGINIA  
 REV. 1/29/02 PURCHASING CONTINUATION SHEET  
 VENDOR:

BUYER CB-23	PAGE 1	REQ OR PD NO DEP 14906
SPENDING UNIT WEST VIRGINIA DEPARTMENT OF ENVIRONMENTAL PROTECTION/OFFICE OF SPECIAL RECLAMATION		

BUFFALO COAL Co  
 S-2018-88  
 EXISTING PIT CROSS SECTION

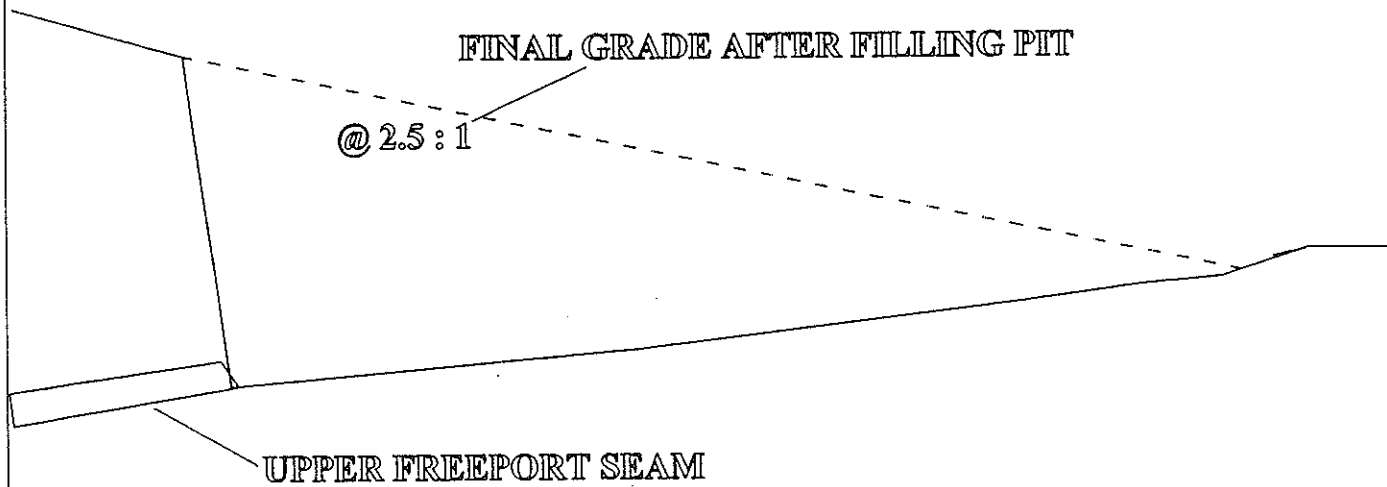

NOTE: CROSS SECTION of the NORTH END  
 of the OPEN PIT. When BACK FILL  
 is COMPLETED the SLOPE will be  
 ESTIMATED 2.5' : 1'

OFFICE OF SPECIAL RECLAMATION	
EXISTING PIT CONDITIONS PIT X-SECTION NORTH END	
SCALE: NOT TO SCALE	DRAWN BY:
DATE:	PROJECT NO: S-2018-88

BUYER CB-23	PAGE	REQ OR PD NO DEP 14906
SPENDING UNIT WEST VIRGINIA DEPARTMENT OF ENVIRONMENTAL PROTECTION/OFFICE OF SPECIAL RECLAMATION		

BUFFALO COAL Co  
 S-2018-88  
 EXISTING PIT CROSS SECTION

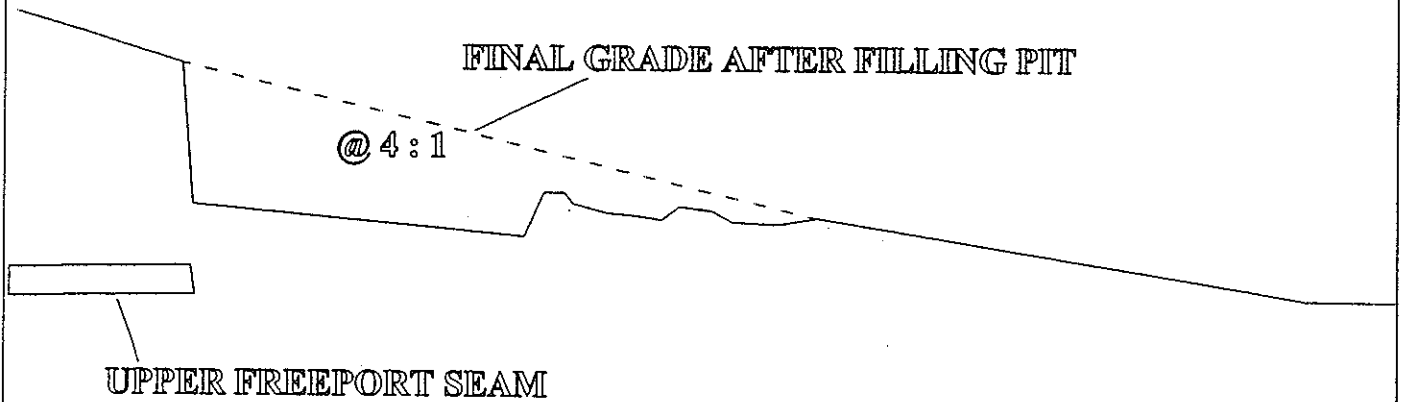

NOTE: CROSS SECTION of the SOUTH END  
 of the OPEN PIT. When BACK FILL  
 is COMPLETED the SLOPE will be  
 APPROX. 4' : 1'

OFFICE OF SPECIAL RECLAMATION	
EXISTING PIT CONDITIONS PIT X-SECTION SOUTH END	
SCALE: NOT TO SCALE	DRAWN BY:
DATE:	PROJECT NO: S-2018-88

WV-36a STATE OF WEST VIRGINIA  
 REV. 1/29/02 PURCHASING CONTINUATION SHEET  
 VENDOR:

BUYER CB-23	PAGE	REQ OR PD NO DEP 14906
SPENDING UNIT WEST VIRGINIA DEPARTMENT OF ENVIRONMENTAL PROTECTION/OFFICE OF SPECIAL RECLAMATION		

BUFFALO COAL Co  
 S-2018-88  
 HAY BALE DIKE PLACEMENT

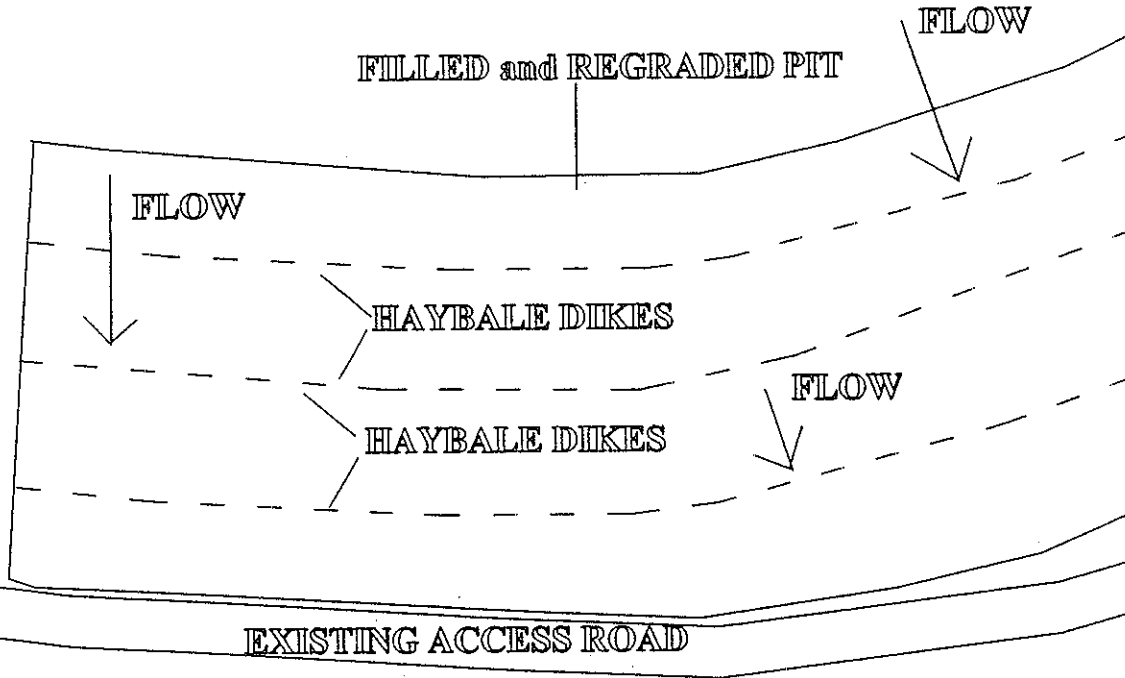

**NOTE: 3 ROWS of HAYBALE DIKES  
 WILL BE EVENLY SPACED DOWN  
 the FACE of the FILLED and GRADED  
 PIT for EROSION PROTECTION.**

OFFICE OF SPECIAL RECLAMATION	
HAY BALE DIKE PLACEMENT FILLED and REGRADED PIT	
SCALE: NOT TO SCALE	DRAWN BY:
DATE:	PROJECT NO: S-2018-88

STRAW/HAY BALE DIKE

2 REBAR, STEEL PICKETS, OR  
2"X2" STAKERS PER BALE  
DRIVEN 1' MIN INTO GROUND

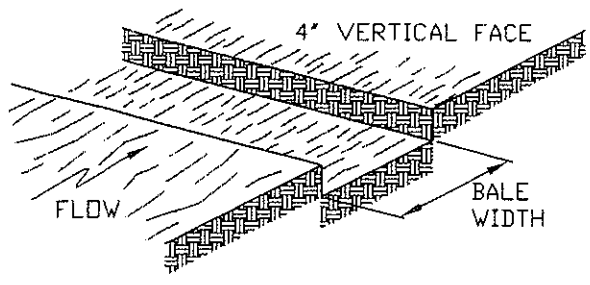

1 EXCAVATE THE TRENCH.

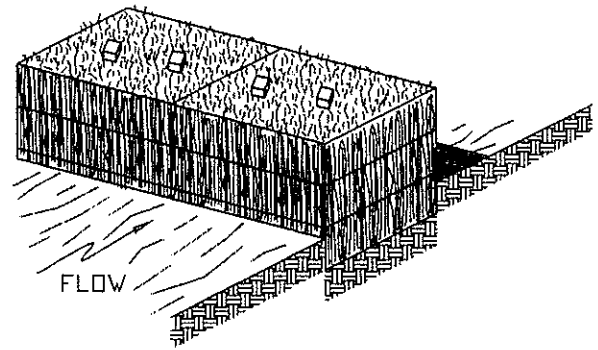

2. PLACE AND STAKE THE BALES

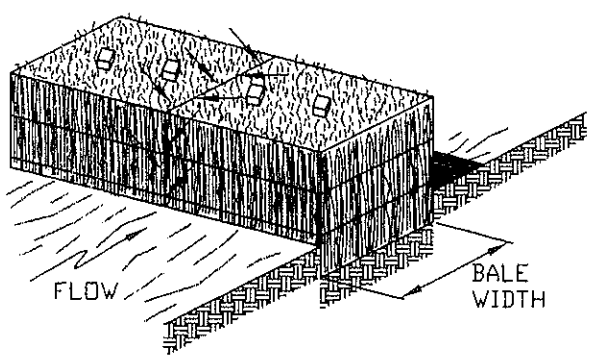

3 WEDGE LOOSE STRAW BETWEEN BALES

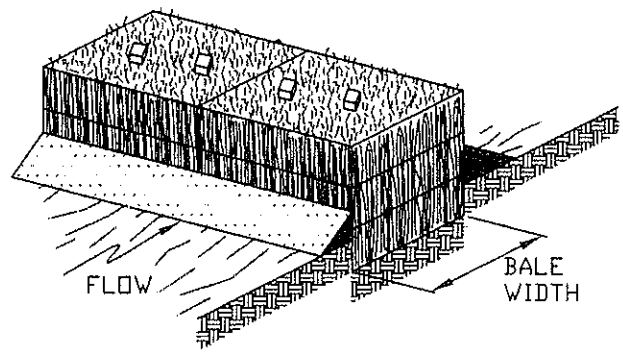

4 BACKFILL AND COMPACT THE EXCAVATED SOIL

HAY OR STRAW BALE INSTALLATION SEQUENCE

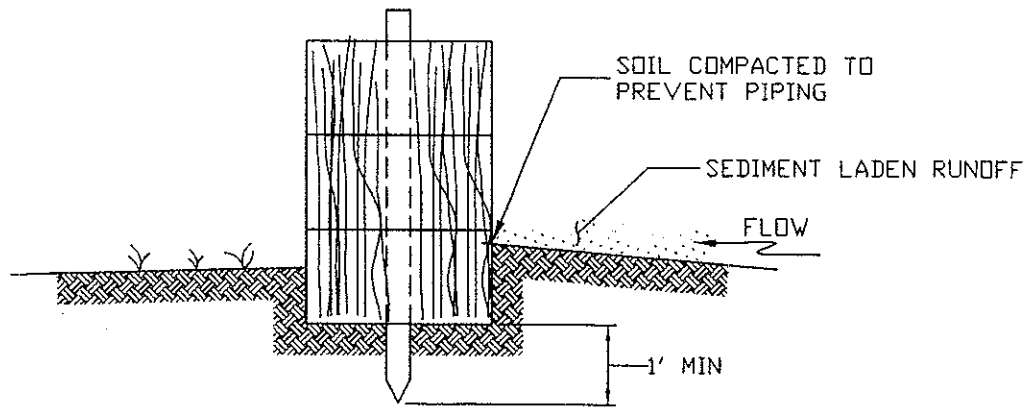

PROPERLY INSTALLED BALE

BUFFALO COAL  
S-2018-88

BUYER CB-23	PAGE	REQ or P.O. No. DEP 14906
----------------	------	------------------------------

SILT FENCE INSTALLATION

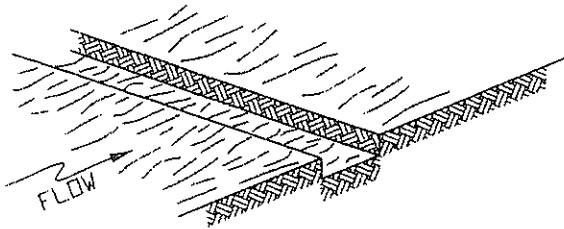

1 EXCAVATE 6' X 6' TRENCH

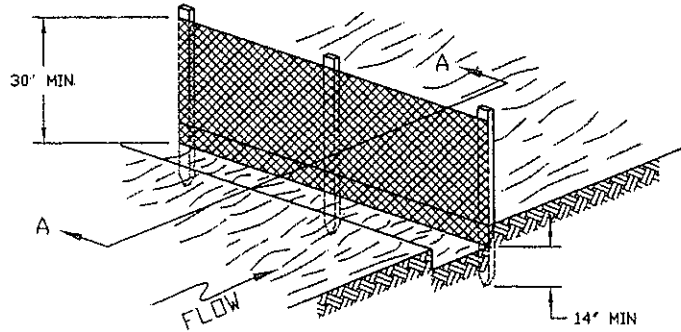

2. PLACE FENCE AT BACK EDGE OF TRENCH (FABRIC FACING DIRECTION OF FLOW)

3 DRIVE POST UNTIL FABRIC REACHES BOTTOM OF TRENCH

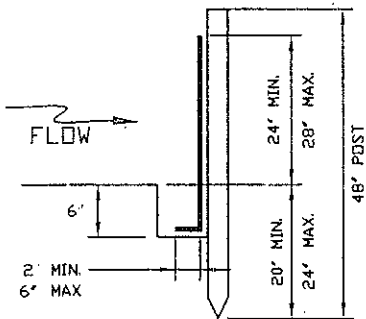

SECTION A-A

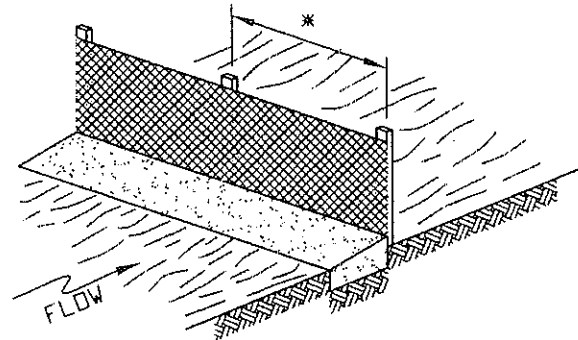

\* SEE SPECIFICATIONS FOR REQUIRED POST SPACING

4 FILL TRENCH WITH EMBANKMENT & TAMP

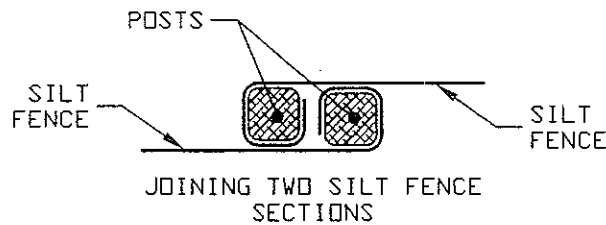

NOTE: WHEN MORE THAN ONE ROLL OF SILT FENCE IS USED, THE FENCE AT THE JUNCTION MUST BE PLACED SO THAT THE LAST POST OF THE FIRST RUN & THE FIRST POST OF THE SECOND RUN OVERLAP & ARE TIED TOGETHER

BUYER CB-23	PAGE 1	REQ. OR PD NO DEP 14906
SPENDING UNIT WEST VIRGINIA DEPARTMENT OF ENVIRONMENTAL PROTECTION/OFFICE OF SPECIAL RECLAMATION		

BUFFALO COAL Co  
S-2018-88  
POND 6 ELIMINATION TYPICAL

POND 6 CROSS SECTION PRIOR to ELIMINATION

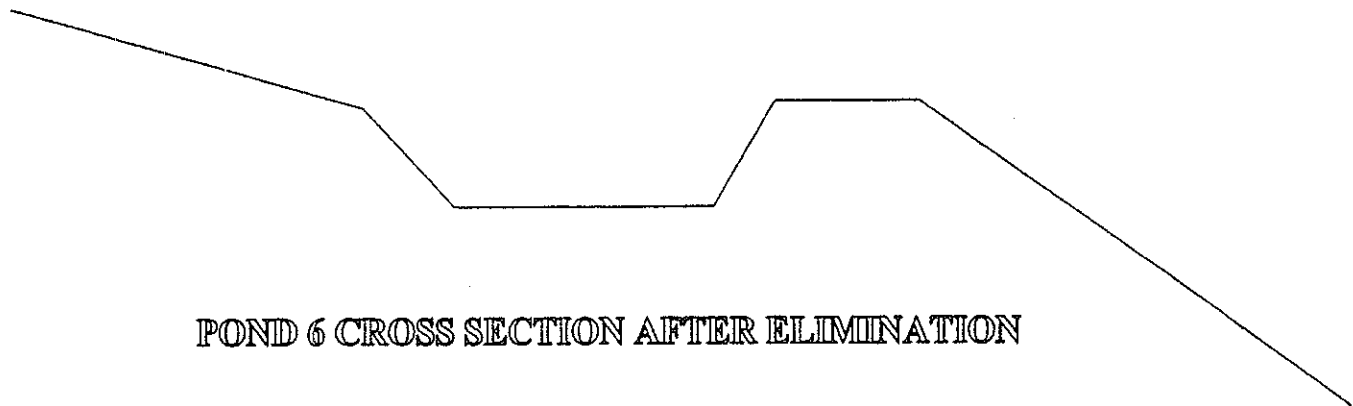

POND 6 CROSS SECTION AFTER ELIMINATION

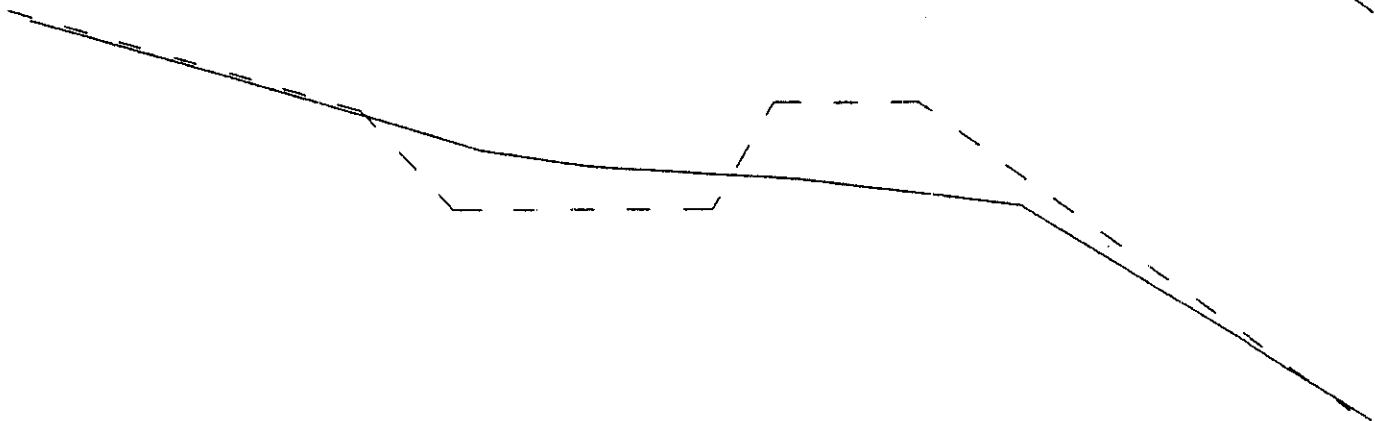

OFFICE OF SPECIAL RECLAMATION	
POND 6 ELIMINATION TYPICAL	
SCALE: NOT TO SCALE	DRAWN BY:
DATE:	PROJECT NO: S-2018-88

Buffalo Coal Permit No. S-2018-88

CB-23

PAGE

DEP 14906

LOCATION MAP

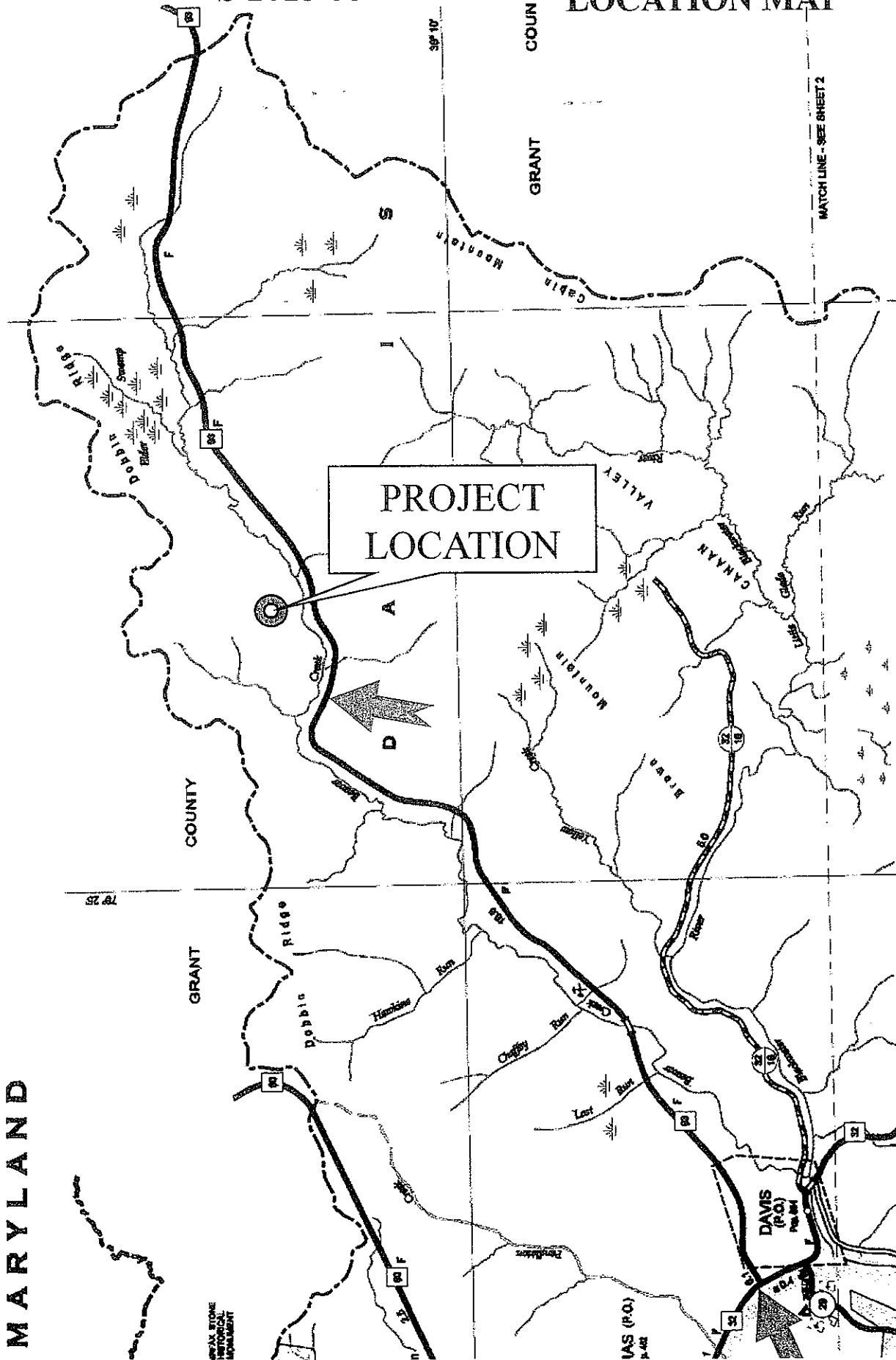

In Tucker County, from the intersection of State Route 32 and 93 near Davis, go 6.2 miles East on Rt 93 to the private haulroad on the left (Mettiki E-Mine Preparation Plant entrance). You will have to check in at the Mettiki guard house and then proceed through their site to get to the bond forfeiture site.

MARYLAND



## AVS OFT Report - 1/5/2010 8:28:04 AM

All OFT's where the selected entity is listed as an entity or related entity

### Entity Selected (248140) Pro Contracting Inc

Parent Entity	Description	Related Entity	% Ownership	Begin Date	End Date
(248140) Pro Contracting Inc	Shareholder	(151167) Matthew Evans	20%	9/18/2008	
(248140) Pro Contracting Inc	Secretary	(151167) Matthew Evans		9/18/2008	
(248140) Pro Contracting Inc	Shareholder	(099850) David B Lang	40%	12/29/2009	
(248140) Pro Contracting Inc	Vice President	(099850) David B Lang		12/29/2009	
(248140) Pro Contracting Inc	Shareholder	(145524) Bryan W Reger	40%	12/29/2009	
(248140) Pro Contracting Inc	President	(145524) Bryan W Reger		9/18/2008	
(248140) Pro Contracting Inc	Shareholder	(145524) Bryan W Reger	80%	9/18/2008	12/29/2009





State of West Virginia  
 Department of Administration  
 Purchasing Division  
 2019 Washington Street East  
 Post Office Box 50130  
 Charleston, WV 25305-0130

# Request for Quotation

RFQ NUMBER  
**DEP14906**

PAGE  
**1**

ADDRESS CORRESPONDENCE TO ATTENTION OF  
**CHUCK BOWMAN**  
**304-558-2157**

**VENDOR**  
 \*B19160306 304-622-2400  
 PRO CONTRACTING INC  
 PO BOX 2442  
 CLARKSBURG WV 26301

**SHIP TO**  
 ENVIRONMENTAL PROTECTION  
 DEPT. OF  
 OFFICE OF SPECIAL RECLAMATION  
 105 S. RAILROAD STREET  
 PHILIPPI, WV  
 26416-9998 304-457-3219

DATE PRINTED	TERMS OF SALE	SHIP VIA	F.O.B.	FREIGHT TERMS
04/07/2010				

BID OPENING DATE: **04/21/2010** BID OPENING TIME **01:30PM**

LINE	QUANTITY	UOP	CAT NO.	ITEM NUMBER	UNIT PRICE	AMOUNT
	*****	*****		ADDENDUM NO. 1	*****	
	ADDENDUM ISSUED FOR THE BUFFALO COAL CO. PROJECT TO DISTRIBUTE THE PRE-BID SIGN-IN SHEETS AND THE Q/A RESULTING FROM THE MANDATORY PRE-BID OF 03/25/10.					
	BID OPENING DATE AND TIME REMAIN UNCHANGED AS 04/21/10 AT 1:30 PM.					
	*****	*****		NO OTHER CHANGES	*****	
0001	1	JB		962-73		
	RECLAMATION: RESTORATION OF LAND					
	***** THIS IS THE END OF RFQ DEP14906 *****					TOTAL: \$ <u>405,050.<sup>00</sup></u>

SEE REVERSE SIDE FOR TERMS AND CONDITIONS

SIGNATURE *[Signature]* TELEPHONE **304-622-2400** DATE **4-20-10**  
 TITLE **Vice President** FEIN **26-3348007** ADDRESS CHANGES TO BE NOTED ABOVE

WHEN RESPONDING TO RFQ, INSERT NAME AND ADDRESS IN SPACE ABOVE LABELED 'VENDOR'

# CONTRACTOR LICENSE

Authorized by the

**West Virginia Contractor Licensing Board**

**Number:**

WV044670

**Classification:**

GENERAL ENGINEERING

PRO CONTRACTING INC  
DBA PRO CONTRACTING INC  
PO BOX 2442  
CLARKSBURG, WV 26301

**Date Issued**

OCTOBER 06, 2009

**Expiration Date**

OCTOBER 06, 2010



Authorized Company Signature



Chair, West Virginia Contractor  
Licensing Board



**WEST VIRGINIA  
CONTRACTOR  
LICENSING  
BOARD**

This license, or a copy thereof, must be posted in a conspicuous place at every construction site where work is being performed. This license number must appear in all advertisements, on all bid submissions and on all fully executed and binding contracts. This license cannot be assigned or transferred by licensee. Issued under provisions of West Virginia Code, Chapter 21, Article 11.

# ACORD CERTIFICATE OF LIABILITY INSURANCE

OP ID, SB  
PROCO-1

DATE (MM/DD/YYYY)  
10/26/09

<b>PRODUCER</b>  United Security Agency 139 West Main Street Bridgeport WV 26330 Phone: 304-842-3314 Fax: 304-842-7321	THIS CERTIFICATE IS ISSUED AS A MATTER OF INFORMATION ONLY AND CONFERS NO RIGHTS UPON THE CERTIFICATE HOLDER. THIS CERTIFICATE DOES NOT AMEND, EXTEND OR ALTER THE COVERAGE AFFORDED BY THE POLICIES BELOW.	
	<b>INSURERS AFFORDING COVERAGE</b>	<b>NAIC #</b>
<b>INSURED</b>  PRO CONTRACTING INC DAVE LANG P O BOX 2442 CLARKSBURG WV 26302-2442	INSURER A: <b>BRICKSTREET INSURANCE</b>	12372
	INSURER B:	
	INSURER C:	
	INSURER D:	
	INSURER E:	

**COVERAGES**

THE POLICIES OF INSURANCE LISTED BELOW HAVE BEEN ISSUED TO THE INSURED NAMED ABOVE FOR THE POLICY PERIOD INDICATED. NOTWITHSTANDING ANY REQUIREMENT, TERM OR CONDITION OF ANY CONTRACT OR OTHER DOCUMENT WITH RESPECT TO WHICH THIS CERTIFICATE MAY BE ISSUED OR MAY PERTAIN, THE INSURANCE AFFORDED BY THE POLICIES DESCRIBED HEREIN IS SUBJECT TO ALL THE TERMS, EXCLUSIONS AND CONDITIONS OF SUCH POLICIES. AGGREGATE LIMITS SHOWN MAY HAVE BEEN REDUCED BY PAID CLAIMS.

INSR ADD'L LTR INSR	TYPE OF INSURANCE	POLICY NUMBER	POLICY EFFECTIVE DATE (MM/DD/YY)	POLICY EXPIRATION DATE (MM/DD/YY)	LIMITS
	<b>GENERAL LIABILITY</b> <input type="checkbox"/> COMMERCIAL GENERAL LIABILITY <input type="checkbox"/> CLAIMS MADE <input type="checkbox"/> OCCUR  GEN'L AGGREGATE LIMIT APPLIES PER: <input type="checkbox"/> POLICY <input type="checkbox"/> PRO-JECT <input type="checkbox"/> LOC				EACH OCCURRENCE \$ DAMAGE TO RENTED PREMISES (Ea occurrence) \$ MED EXP (Any one person) \$ PERSONAL & ADV INJURY \$ GENERAL AGGREGATE \$ PRODUCTS - COMP/OP AGG \$
	<b>AUTOMOBILE LIABILITY</b> <input type="checkbox"/> ANY AUTO <input type="checkbox"/> ALL OWNED AUTOS <input type="checkbox"/> SCHEDULED AUTOS <input type="checkbox"/> HIRED AUTOS <input type="checkbox"/> NON-OWNED AUTOS				COMBINED SINGLE LIMIT (Ea accident) \$ BODILY INJURY (Per person) \$ BODILY INJURY (Per accident) \$ PROPERTY DAMAGE (Per accident) \$
	<b>GARAGE LIABILITY</b> <input type="checkbox"/> ANY AUTO				AUTO ONLY - EA ACCIDENT \$ OTHER THAN AUTO ONLY: EA ACC \$ AGG \$
	<b>EXCESS/UMBRELLA LIABILITY</b> <input type="checkbox"/> OCCUR <input type="checkbox"/> CLAIMS MADE  <input type="checkbox"/> DEDUCTIBLE RETENTION \$				EACH OCCURRENCE \$ AGGREGATE \$ \$ \$
A	<b>WORKERS COMPENSATION AND EMPLOYERS' LIABILITY</b> ANY PROPRIETOR/PARTNER/EXECUTIVE OFFICER/MEMBER EXCLUDED? If yes, describe under SPECIAL PROVISIONS below	WC10211754-02	10/01/09	10/01/10	<input checked="" type="checkbox"/> WC STATUTORY LIMITS <input type="checkbox"/> OTHER E.L. EACH ACCIDENT \$ 100000 E.L. DISEASE - EA EMPLOYEE \$ 100000 E.L. DISEASE - POLICY LIMIT \$ 500000
	OTHER				

DESCRIPTION OF OPERATIONS / LOCATIONS / VEHICLES / EXCLUSIONS ADDED BY ENDORSEMENT / SPECIAL PROVISIONS

**CERTIFICATE HOLDER**

**CANCELLATION**

PROCON2  PRO CONTRACTING, INC P.O. BOX 2442 CLARKSBURG WV 25302	SHOULD ANY OF THE ABOVE DESCRIBED POLICIES BE CANCELLED BEFORE THE EXPIRATION DATE THEREOF, THE ISSUING INSURER WILL ENDEAVOR TO MAIL _____ DAYS WRITTEN NOTICE TO THE CERTIFICATE HOLDER NAMED TO THE LEFT. BUT FAILURE TO DO SO SHALL IMPOSE NO OBLIGATION OR LIABILITY OF ANY KIND UPON THE INSURER, ITS AGENTS OR REPRESENTATIVES.  AUTHORIZED REPRESENTATIVE Sharon Boyles <i>Sharon Boyles</i>
---	---

**BID BOND**

KNOW ALL MEN BY THESE PRESENTS, That we, the undersigned, Pro Contracting, Inc.  
of P. O. Box 2442, Clarksburg, WV 26302, as Principal, and Travelers Casualty and Surety Company  
of America of 1 Tower Sq., 5PB, Hartford, CT, a corporation organized and existing under the laws of the State of Connecticut  
with its principal office in the City of Hartford, as Surety, are held and firmly bound unto the State  
of West Virginia, as Oblige, in the penal sum of Five Percent of the total amount bid (\$ 5%) for the payment of which,  
well and truly to be made, we jointly and severally bind ourselves, our heirs, administrators, executors, successors and assigns.

The Condition of the above obligation is such that whereas the Principal has submitted to the Purchasing Section of the  
Department of Administration a certain bid or proposal, attached hereto and made a part hereof, to enter into a contract in writing for  
**DEP 14906: Buffalo Coal Company**  
**Tucker County, WV**

**NOW THEREFORE,**

- (a) If said bid shall be rejected, or
- (b) If said bid shall be accepted and the Principal shall enter into a contract in accordance with the bid or proposal attached hereto and shall furnish any other bonds and insurance required by the bid or proposal, and shall in all other respects perform the agreement created by the acceptance of said bid, then this obligation shall be null and void, otherwise this obligation shall remain in full force and effect. It is expressly understood and agreed that the liability of the Surety for any and all claims hereunder shall, in no event, exceed the penal amount of this obligation as herein stated.

The Surety, for the value received, hereby stipulates and agrees that the obligations of said Surety and its bond shall be in no way impaired or affected by any extension of the time within which the Oblige may accept such bid, and said Surety does hereby waive notice of any such extension.

IN WITNESS WHEREOF, Principal and Surety have hereunto set their hands and seals, and such of them as are corporations have caused their corporate seals to be affixed hereunto and these presents to be signed by their proper officers, this  
21st day of April, 2010

Principal Corporate Seal

Pro Contracting, Inc.

(Name of Principal)

By AWK

(Must be President or Vice President)

President

(Title)

Surety Corporate Seal

Travelers Casualty and Surety Company of America

(Name of Surety)

[Signature]  
Attorney-in-Fact

**IMPORTANT -- Surety executing bonds must be licensed in West Virginia to transact surety insurance. Raised corporate seals must be affixed, a power of attorney must be attached.**



POWER OF ATTORNEY

Farmington Casualty Company
Fidelity and Guaranty Insurance Company
Fidelity and Guaranty Insurance Underwriters, Inc.
St. Paul Fire and Marine Insurance Company
St. Paul Guardian Insurance Company

St. Paul Mercury Insurance Company
Travelers Casualty and Surety Company
Travelers Casualty and Surety Company of America
United States Fidelity and Guaranty Company

Attorney-In Fact No. 218346

Certificate No. 003280009

KNOW ALL MEN BY THESE PRESENTS: That St Paul Fire and Marine Insurance Company St. Paul Guardian Insurance Company and St Paul Mercury Insurance Company are corporations duly organized under the laws of the State of Minnesota that Farmington Casualty Company, Travelers Casualty and Surety Company, and Travelers Casualty and Surety Company of America are corporations duly organized under the laws of the State of Connecticut, that United States Fidelity and Guaranty Company is a corporation duly organized under the laws of the State of Maryland, that Fidelity and Guaranty Insurance Company is a corporation duly organized under the laws of the State of Iowa, and that Fidelity and Guaranty Insurance Underwriters, Inc, is a corporation duly organized under the laws of the State of Wisconsin (herein collectively called the "Companies"), and that the Companies do hereby make, constitute and appoint

C. David Thomas Richard L. Higginbotham, Bunnie Marie Perrine, Jeffery O'Dell, and Robin Hubbard-Sherrod

of the City of Charleston State of West Virginia, their true and lawful Attorney(s)-in-Fact, each in their separate capacity if more than one is named above, to sign, execute, seal and acknowledge any and all bonds, recognizances, conditional undertakings and other writings obligatory in the nature thereof on behalf of the Companies in their business of guaranteeing the fidelity of persons guaranteeing the performance of contracts and executing or guaranteeing bonds and undertakings required or permitted in any actions or proceedings allowed by law.

IN WITNESS WHEREOF the Companies have caused this instrument to be signed and their corporate seals to be hereto affixed, this 5th day of October, 2009

Farmington Casualty Company
Fidelity and Guaranty Insurance Company
Fidelity and Guaranty Insurance Underwriters, Inc
St. Paul Fire and Marine Insurance Company
St. Paul Guardian Insurance Company

St. Paul Mercury Insurance Company
Travelers Casualty and Surety Company
Travelers Casualty and Surety Company of America
United States Fidelity and Guaranty Company



State of Connecticut
City of Hartford ss

By: George W. Thompson Senior Vice President

On this the 5th day of October, 2009, before me personally appeared George W. Thompson, who acknowledged himself to be the Senior Vice President of Farmington Casualty Company, Fidelity and Guaranty Insurance Company, Fidelity and Guaranty Insurance Underwriters, Inc., St. Paul Fire and Marine Insurance Company, St. Paul Guardian Insurance Company, St. Paul Mercury Insurance Company, Travelers Casualty and Surety Company, Travelers Casualty and Surety Company of America and United States Fidelity and Guaranty Company and that he as such being authorized so to do, executed the foregoing instrument for the purposes therein contained by signing on behalf of the corporations by himself as a duly authorized officer

In Witness Whereof, I hereunto set my hand and official seal
My Commission expires the 30th day of June 2011



Marie C. Tetreault
Marie C Tetreault Notary Public

This Power of Attorney is granted under and by the authority of the following resolutions adopted by the Boards of Directors of Farmington Casualty Company Fidelity and Guaranty Insurance Company, Fidelity and Guaranty Insurance Underwriters, Inc., St. Paul Fire and Marine Insurance Company St. Paul Guardian Insurance Company, St. Paul Mercury Insurance Company Travelers Casualty and Surety Company, Travelers Casualty and Surety Company of America and United States Fidelity and Guaranty Company which resolutions are now in full force and effect, reading as follows:

**RESOLVED**, that the Chairman the President any Vice Chairman any Executive Vice President, any Senior Vice President, any Vice President, any Second Vice President, the Treasurer, any Assistant Treasurer, the Corporate Secretary or any Assistant Secretary may appoint Attorneys-in-Fact and Agents to act for and on behalf of the Company and may give such appointee such authority as his or her certificate of authority may prescribe to sign with the Company's name and seal with the Company's seal bonds, recognizances, contracts of indemnity and other writings obligatory in the nature of a bond recognizance, or conditional undertaking and any of said officers or the Board of Directors at any time may remove any such appointee and revoke the power given him or her; and it is

**FURIHER RESOLVED** that the Chairman, the President any Vice Chairman, any Executive Vice President any Senior Vice President or any Vice President may delegate all or any part of the foregoing authority to one or more officers or employees of this Company, provided that each such delegation is in writing and a copy thereof is filed in the office of the Secretary; and it is

**FURIHER RESOLVED**, that any bond recognizance, contract of indemnity, or writing obligatory in the nature of a bond, recognizance, or conditional undertaking shall be valid and binding upon the Company when (a) signed by the President, any Vice Chairman any Executive Vice President, any Senior Vice President or any Vice President, any Second Vice President, the Treasurer, any Assistant Treasurer, the Corporate Secretary or any Assistant Secretary and duly attested and sealed with the Company's seal by a Secretary or Assistant Secretary; or (b) duly executed (under seal, if required) by one or more Attorneys-in-Fact and Agents pursuant to the power prescribed in his or her certificate or their certificates of authority or by one or more Company officers pursuant to a written delegation of authority; and it is

**FURIHER RESOLVED**, that the signature of each of the following officers: President, any Executive Vice President, any Senior Vice President, any Vice President, any Assistant Vice President, any Secretary any Assistant Secretary, and the seal of the Company may be affixed by facsimile to any Power of Attorney or to any certificate relating thereto appointing Resident Vice Presidents, Resident Assistant Secretaries or Attorneys-in-Fact for purposes only of executing and attesting bonds and undertakings and other writings obligatory in the nature thereof, and any such Power of Attorney or certificate bearing such facsimile signature or facsimile seal shall be valid and binding upon the Company and any such power so executed and certified by such facsimile signature and facsimile seal shall be valid and binding on the Company in the future with respect to any bond or understanding to which it is attached

I, Kori M Johanson, the undersigned, Assistant Secretary, of Farmington Casualty Company Fidelity and Guaranty Insurance Company, Fidelity and Guaranty Insurance Underwriters, Inc., St. Paul Fire and Marine Insurance Company, St. Paul Guardian Insurance Company St. Paul Mercury Insurance Company, Travelers Casualty and Surety Company, Travelers Casualty and Surety Company of America, and United States Fidelity and Guaranty Company do hereby certify that the above and foregoing is a true and correct copy of the Power of Attorney executed by said Companies, which is in full force and effect and has not been revoked

IN TESTIMONY WHEREOF I have hereunto set my hand and affixed the seals of said Companies this 21st day of April 2010

  
Kori M Johanson, Assistant Secretary

WARNING: THIS POWER OF ATTORNEY IS INVALID WITHOUT THE RED BORDER



To verify the authenticity of this Power of Attorney call 1-800-421-3880 or contact us at www.travelersbond.com Please refer to the Attorney-In-Fact number the above-named individuals and the details of the bond to which the power is attached



State of West Virginia  
DRUG FREE WORKPLACE CONFORMANCE AFFIDAVIT  
West Virginia Code §21-1D-5

STATE OF West Virginia

COUNTY OF Harrison, TO-WIT:

I, Bryan W. Reger, after being first duly sworn, depose and state as follows:

- 1. I am an employee of Pro Contracting, Inc.; and,  
(Company Name)
- 2. I do hereby attest that Pro Contracting, Inc.  
(Company Name)

maintains a valid written drug free workplace policy and that such policy is in compliance with **West Virginia Code §21-1D-5**.

The above statements are sworn to under the penalty of perjury.

Pro Contracting, Inc.  
(Company Name)

By: BWR

Title: President

Date: 4-20-10

Taken, subscribed and sworn to before me this 20<sup>th</sup> day of April, 2010

By Commission expires 1-28-19

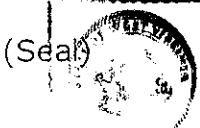

OFFICIAL SEAL  
NOTARY PUBLIC  
State of West Virginia  
DAVID B. LANG  
270 Buchanan Ave.  
Martinsburg, WV 26301  
January 28, 2010

[Signature]  
(Notary Public)

**THIS AFFIDAVIT MUST BE SUBMITTED WITH THE BID IN ORDER TO COMPLY WITH WV CODE PROVISIONS. FAILURE TO INCLUDE THE AFFIDAVIT WITH THE BID SHALL RESULT IN DISQUALIFICATION OF THE BID.**

RFQ No. DEP14906

STATE OF WEST VIRGINIA  
Purchasing Division

**PURCHASING AFFIDAVIT**

**West Virginia Code §5A-3-10a states:** No contract or renewal of any contract may be awarded by the state or any of its political subdivisions to any vendor or prospective vendor when the vendor or prospective vendor or a related party to the vendor or prospective vendor is a debtor and the debt owed is an amount greater than one thousand dollars in the aggregate.

**DEFINITIONS:**

"Debt" means any assessment, premium, penalty, fine, tax or other amount of money owed to the state or any of its political subdivisions because of a judgment, fine, permit violation, license assessment, defaulted workers' compensation premium, penalty or other assessment presently delinquent or due and required to be paid to the state or any of its political subdivisions, including any interest or additional penalties accrued thereon

"Debtor" means any individual, corporation, partnership, association, limited liability company or any other form or business association owing a debt to the state or any of its political subdivisions. "Political subdivision" means any county commission; municipality; county board of education; any instrumentality established by a county or municipality; any separate corporation or instrumentality established by one or more counties or municipalities, as permitted by law; or any public body charged by law with the performance of a government function or whose jurisdiction is coextensive with one or more counties or municipalities. "Related party" means a party, whether an individual, corporation, partnership, association, limited liability company or any other form or business association or other entity whatsoever, related to any vendor by blood, marriage, ownership or contract through which the party has a relationship of ownership or other interest with the vendor so that the party will actually or by effect receive or control a portion of the benefit, profit or other consideration from performance of a vendor contract with the party receiving an amount that meets or exceed five percent of the total contract amount

**EXCEPTION:** The prohibition of this section does not apply where a vendor has contested any tax administered pursuant to chapter eleven of this code, workers' compensation premium, permit fee or environmental fee or assessment and the matter has not become final or where the vendor has entered into a payment plan or agreement and the vendor is not in default of any of the provisions of such plan or agreement

Under penalty of law for false swearing (*West Virginia Code §61-5-3*), it is hereby certified that the vendor affirms and acknowledges the information in this affidavit and is in compliance with the requirements as stated

**WITNESS THE FOLLOWING SIGNATURE**

Vendor's Name: Pro Contracting, Inc.

Authorized Signature: *B. W. L.* Date: 4-20-10

State of West Virginia

County of Harrison, to-wit:

Taken, subscribed, and sworn to before me this 20<sup>th</sup> day of April, 2010

My Commission expires 1-28, 2019.

AFFIX SEAL HERE

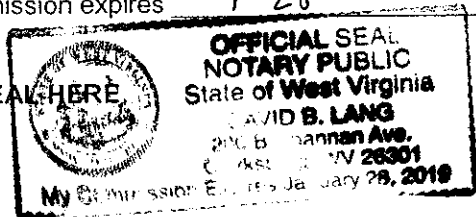

NOTARY PUBLIC

*[Signature]*