



State of West Virginia
 Department of Administration
 Purchasing Division
 2019 Washington Street East
 Post Office Box 50130
 Charleston, WV 25305-0130

Request for Quotation

RFQ NUMBER
AGR1001

PAGE
1

ADDRESS CORRESPONDENCE TO ATTENTION OF
RON PRICE 304-558-0492

VENDOR

*709043751 304-366-4690
 MIDDLETOWN TRACTOR SALES
 2345 WHITEHALL BLVD

 FAIRMONT WV 26554

SHIP TO

DEPARTMENT OF AGRICULTURE
 LAND DIVISION
 HUTTONSVILLE STATE FARM
 ROUTE 250 SOUTH
 HUTTONSVILLE, WV
 26273 304-558-2222

DATE PRINTED 07/19/2009	TERMS OF SALE NET 30	SHIP VIA OUR TRUCK	F.O.B. DEST.	FREIGHT TERMS PREPAID
BID OPENING DATE: 08/11/2009		BID OPENING TIME 01:30PM		

LINE	QUANTITY	UOP	CAT. NO.	ITEM NUMBER	UNIT PRICE	AMOUNT
0001	1	EA		020-89	\$51,699.65	\$51,699.65
<p>4 WD FARM TRACTOR WITH BUSH HOG LOADER AND CAB * We are bidding a J.D. 5095M 9563 loader, per the attached specs. MCCORMICK CX90 (T3) 4WD FARM TRACTOR WITH MODEL 5045 BUSH HOG LOADER & CAB (OR EQUAL). TRACTOR MUST BE 2009 MODEL OR NEWER, ENGINE: 83 HP MIN., PTO CAPACITY: 66 HP MIN., FUEL TANK: 40 GAL MIN. ADDITIONAL SPECIFICATIONS ARE ATTACHED THE MODEL/BRAND/SPECIFICATIONS NAMED HEREIN ESTABLISH THE ACCEPTABLE LEVEL OF QUALITY ONLY AND ARE NOT INTENDED TO REFLECT A PREFERENCE OR FAVOR ANY PARTICULAR BRAND OR VENDOR. VENDORS WHO ARE BIDDING ALTERNATES SHOULD SO STATE AND INCLUDE PERTINENT LITERATURE AND SPECIFICATIONS. FAILURE TO PROVIDE INFORMATION FOR ANY ALTERNATES MAY BE GROUNDS FOR REJECTION OF THE BID. THE STATE RESERVES THE RIGHT TO WAIVE MINOR IRREGULARITIES IN BIDS OR SPECIFICATIONS IN ACCORDANCE WITH SECTION 148-1-4(F) OF THE WEST VIRGINIA LEGISLATIVE RULES AND REGULATIONS.</p> <p style="text-align: center;">NOTICE</p> <p>A SIGNED BID MUST BE SUBMITTED TO: DEPARTMENT OF ADMINISTRATION PURCHASING DIVISION BUILDING 15 2019 WASHINGTON STREET, EAST CHARLESTON, WV 25305-0130</p>						

RECEIVED
 2009 AUG 11 A 10:36
 PURCHASING DIVISION
 STATE OF WV

SEE REVERSE SIDE FOR TERMS AND CONDITIONS			
SIGNATURE <i>J.A. Boyer</i>	TELEPHONE 304-366-4690	DATE 8-7-09	
TITLE VP	FEIN 550547175	ADDRESS CHANGES TO BE NOTED ABOVE	

WHEN RESPONDING TO RFQ, INSERT NAME AND ADDRESS IN SPACE ABOVE Labeled 'VENDOR'



State of West Virginia
 Department of Administration
 Purchasing Division
 2019 Washington Street East
 Post Office Box 50130
 Charleston, WV 25305-0130

Request for Quotation

RFQ NUMBER
AGR1001

PAGE
2

ADDRESS CORRESPONDENCE TO ATTENTION OF:
RON PRICE
304-558-0492

VENDOR

*709043751 304-366-4690
 MIDDLETOWN TRACTOR SALES
 2345 WHITEHALL BLVD
 FAIRMONT WV 26554

SHIP TO

DEPARTMENT OF AGRICULTURE
 LAND DIVISION
 HUTTONSVILLE STATE FARM
 ROUTE 250 SOUTH
 HUTTONSVILLE, WV
 26273 304-558-2222

DATE PRINTED	TERMS OF SALE	SHIP VIA	F.O.B.	FREIGHT TERMS
07/19/2009				

BID OPENING DATE: **08/11/2009** BID OPENING TIME: **01:30PM**

LINE	QUANTITY	UOP	CAT. NO.	ITEM NUMBER	UNIT PRICE	AMOUNT
<p>THE BID SHOULD CONTAIN THIS INFORMATION ON THE FACE OF THE ENVELOPE OR THE BID MAY NOT BE CONSIDERED:</p> <p>SEALED BID</p> <p>BUYER: RP-41</p> <p>RFQ. NO.: AGR1001</p> <p>BID OPENING DATE: 08/11/09</p> <p>BID OPENING TIME: 1:30PM</p> <p>PLEASE PROVIDE A FAX NUMBER IN CASE IT IS NECESSARY TO CONTACT YOU REGARDING YOUR BID: 304-366-4698</p> <p>CONTACT PERSON (PLEASE PRINT CLEARLY): STEVE CROWIN</p>						

SEE REVERSE SIDE FOR TERMS AND CONDITIONS

SIGNATURE <i>J.A. Boyer</i>	TELEPHONE	DATE
TITLE	FEIN	ADDRESS CHANGES TO BE NOTED ABOVE

WHEN RESPONDING TO RFQ, INSERT NAME AND ADDRESS IN SPACE ABOVE LABELED 'VENDOR'

Addn. Specifications- Tractor with Bush Hog Loader

Engine: Diesel 4 cylinder turbocharged, Cold Start Package,
 Min. Displacement 268 cubic inches
 Transmission: 24x24 xtrashift, power shuttle, Left Hand Reverser,
 Power Take Off-Wet Multi-disc 540/1000
 Front 4WD- Electro-hydraulic Engagement,
 Hydraulics: Power Steering Pump: 7.9 GPM (Min.)
 Pump Flow: 15.7GPM (Min.)
 Total: 23.6 GPM (Min.)

Wet Clutch

Electro Hydraulic Differential Lock

Maximum Steering Angle: 55 degrees\

Wet brakes- with auto engagement 4WD with braking

Hydraulic Lift: 4,347 lbs. (Min)

Cat II Hitch

Tires: Front 320/85R24, 420/85R34 Rear

Dimensions & Weight Specifications:

Length: 166" (Min.)

Wheelbase: 92.7" (Min.)

Width: 92.3" (Min.)

Weight: 8465 lbs. (Min.)

Ground Clearance: 16.5' (Min.)

Tool box and Front Hood/ Grill Guard

Mid-Mount Setup on Hydraulics

W/ 2 SCV Ports independently operated on rear

Deluxe Cab with Air Conditioning

Model 5045 Bush Hog Loader with Quick Attach Bale Spear
 And 84" Commercial Materials Bucket

(Specifications)

Lift Capacity at full height: 3500 lbs. (min.)

Breakout force: 5,000 lbs. (min.).

Lift Height: 126" (min.)

Rollback force: 5,100 lbs. (min)

Dump Angle: 45 degrees (min.), Lift Capacity @ 59": 4,100 lbs. (min)

Digging Depth: 3.5" (min.)

Loader Specs.- Continued

Loader must be fully assembled and attached to tractor at delivery.
Tractor must be fully assembled, with tires set out full width.
Min Warranty: 2 years. Delivered and demonstrated at the Huttonsville Farm.

Warranty must include transportation costs to and from the farm to vendor's shop if needed during warranty period of 2 years..

Direct any questions to: Dwayne O'Dell, Assistant Director,
Marketing & Development Division, 304 558-2210 (o)
or 304 541-5460 (cell).

Tractor w/loader is to be delivered, assembled, and demonstrated to the Huttonsville Farm by November 1, 2009 or sooner.

Met or Exceed Spec.

MANUFACTURER	John Deere
MODEL	5095M
Official Test	
Nebraska Test Number	Factory observed
Engine	
Manufacturer	John Deere PowerTech M 4045
Aspiration	Turbocharged
Cylinders/Displacement, cu. in. (liters)	4/276 (4.5)
Cylinder Liners	Wet Sleeved
Fuel Tank Cap., US Gal. (L) (Open; Cab)	---
Standard	29 (110); 38 (144)
Optional	---
Underhood muffler	Yes
Performance	
Advertised PTO HP (kW) @ Rated RPM	80 (59.6) @ 2100 per SAE
Official PTO HP (kW) @ Rated RPM	---
@ Standard PTO @ Eng RPM	---
Maximum @ Eng RPM	---
Advertised Engine HP (kW) @ Rated Speed	95 (70.8) @ 2200 per 97/68/EC
Max Unballast Drwbr HP (kW) @ Eng RPM	---
Maximum Torque (PTO) @ RPM, lb-ft (Nm)	372 @ 1600
Max Torque Rise (80% Rtd Spd) @ Eng RPM	---
Maximum Torque Rise % (PTO) @ Eng RPM	26 @ 1600
Fuel Use, U.S. gal./hr. & HP hr./gal. at:	
PTO @ Rated Eng RPM	---
Standard PTO Speed @ Eng Speed	---
Maximum PTO Power @ Eng RPM	---
Maximum Engine Power @ Eng RPM	---
Max Unballasted Drawbar Power @ Eng RPM	---
75% Load, Full Engine RPM (Unballasted)	---
75% Load @ Reduced RPM (Unballasted)	---
Transmission	
Std. Transmission; Forward/Reverse	16F/16R SyncReverser 12F/4R SyncShuttle Plus,
Opt. Transmission; Forward/Reverse	16F/16R PowrReverser, 32F/16R PowrReverser Plus
Reverser	Left Hand, Mechanical
On-the-Go Shifting (Yes/No/Partial)	Partial
Clutch; Wet/Dry	Wet
Creeper	12F/4R SyncShuttle Plus, 16F/16R PowrReverser, 32F/16R PowrReverser Plus
Power Take-Off (PTO)	
Standard	Independent 540/540 Economy
Optional	540/540E/1000
PTO Speeds @ Engine RPM	540 @ 2100; 540E @ 1645
PTO Actuation	Electrohydraulic
Hydraulics	
Type	Open Center
Pump Rated Output, GPM (L/min.)	---
Standard	24.7 (93.6)
Optional	---
Rated Flow @ One SCV, GPM (L/min.)	18.4 (69.9)
Max Output @ SCV Couplers, GPM (L/min.)	---
Maximum Operating Pressure, PSI (kPa)	2900 (20000)
Maximum Hydraulic Power, HP (kW)	31.1 (23.2)
Hitch Draft Control Load Sense Type	Mechanical or Electrohydraulic
Remote Control Valves Available	0 (opt. 3)

Hitch Category (SAE Designation)	2; convertible to 1
Hitch Lift Cap. lb. (kg) @24"Bhnd Lift Pt.	---
OECD	---
Standard	3595 (1631)
Optional	4498 (2041)
Hitch Lift Cap. lb. (kg) @24"Bhnd Lift Pt. (SAE)	---
Standard	---
Optional	---
Hitch Lift Cap. lb. (kg) @24"Bhnd Lift Pt. (ASAE)	---
Standard	---
Optional	---
Sensing Type	Lower Link
Joystick SCV Control	Optional
Final Drive	
Type	Inboard Planetary
Differential Controls	Electrohydraulic
Availability	---
Front	No
Front & Rear	No
Engage On-the-Go Rear Differential Lock	Yes
Axle Type	Flanged
Brakes, Type and Control	Hydraulic Wet Disc
Operator Station	
Rollover Protective Structure, OOS	---
Rigid - Foldable - Telescopic	Foldable, 2-Post
Platform - Flat/Straddle	Flat
Gearshift Location - Console/Floor	Floor
Cab	---
Doors	2
Platform - Flat/Straddle	Flat
dB(A) Rating	80
Seat Suspension System	Mechanical (opt. Air Ride)
2WD Dimensions	
Wheelbase, in. (mm)	85.6 (2175)
Front Tread Range, in. (mm)	57.6 - 82.6 (1463 - 2098)
Rear Tread Range, in. (mm)	53.1 - 80.9 (1348-2054)
Minimum Rear Tread Setting, in. (mm)	53.1 (1348)
Front Axle Clearance, in. (mm)	18.8 (477.5)
Turning Radius w/Brakes, ft. (m)	11.2 (3.51)
Turning Radius w/o Brakes, ft. (m)	12.8 (3.90)
Unballasted Operating Weight, lb. (kg)	---
Approx. Ship Wgt, lb. (kg) Open; Cab	6500 (2948); 7700 (3515)
MFWD Dimensions	
Wheelbase, in. (mm)	85.6 (2175)
Front Tread Range, in. (mm)	52.8 - 75.0 (1340 - 1904)
Front Axle Clearance, in. (mm)	17.9 (454)
Turning Radius w/Brakes, ft. (m)	11.6 (3.5)
Turning Radius w/o Brakes, ft. (m)	12.8 (3.9)
Limited Slip Differential	Yes
Unballasted Operating Weight, lb. (kg)	---
Approx. Ship Wgt, lb. (kg) Open; Cab	7000 (3175); 8150 (3697)
4WD Dimensions	
Wheelbase, in. (mm)	---
Wheel Tread, Min. to Max. in. (mm)	---
Turning Radius w/o Brakes, ft. (m)	---
Nebraska Test Unballasted w/Duals, lb.(kg)	---
Unballasted Weight, lb. (kg)	---
Standard Tires	
2WD	---
Front	11L-15 8PR F2
Rear	480/80R30 R1W
MFWD	---

Front	12.4R24 R1
Rear	480/80R30 R1W
4WD	---
Track Widths	---
Miscellaneous	
Country of Manufacture	Augusta, GA
Ballasting Restrictions, lb. (kg)	---
*Notes	Updated 9/30/2008

Specifications are based on published information at the time of publication. Specifications are subject to change without notice. Contact your local John Deere dealer for more information.

MARY OR EXCEED SPEC.

MANUFACTURER	John Deere
MODEL	563 NSL on 5095M Tractor
Tractor	
Model	5095M Tractor
Front Tire	11.2-24
Rear Tire	16.9R30
Wheelbase	85.7-in. (2178 mm)
Pump capacity, gpm	18.4 gpm
Rated pressure, psi	2828 psi
Loader	
Bucket used	500 Style General Purpose - 73-in. (1850 mm)
Bucket weight, lb. (kg)	392 lb. (178 kg)
Lift capacity at full height, lb. (kg)	---
Measured at pivot (U)	3982 lb. (1806 kg)
Measured at 500 mm ahead of pivot (V)	---
Measured at 800 mm ahead of pivot (V)	2769 lb. (1256 kg)
Lift capacity at 59-in. (1.5 m), lb. (kg)	---
Measured at pivot (W)	5093 lb. (2310 kg)
Measured at 500 mm ahead of pivot (X)	---
Measured at 800 mm ahead of pivot (X)	3847 lb. (1745 kg)
Boom Breakout Force, lb. (kg)	---
Measured at pivot (Y)	6654 lb. force (29.6 kN)
Measured at 500 mm ahead of pivot (Z)	---
Measured at 800 mm ahead of pivot (Z)	4811 lb. force (21.4 kN)
Bucket Rollback Force capacity, lb. (kg)	---
At maximum height (VV)	3372 lb. force (15.0 kN)
At 1.5 m (59-in.) lift height (XX)	4811 lb. force (21.4 kN)
At ground level line (ZZ)	4991 lb. force (22.2 kN)
Dimensions	
Maximum lift height, in. (mm) (A)	133-in. (3367 mm)
Clearance	---
At full height - bucket level, in. (mm) (B)	123-in. (3114 mm)
At full height - bucket dumped, in. (mm) (C)	97-in. (2459 mm)
Overall length (I+F), ft. (m)	14.43 ft. (4.4 m)
Overall height in carry position (J), ft. (m)	---
Digging depth, in. (mm) (H)	-9.2-in. (-234 mm)
Reach	---
At max. height, in. (mm) (D)	50-in. (1260 mm)
At ground level - bucket level, in. (mm) (F)	88-in. (2228 mm)
Bucket Angle	---
Dump angle, degrees (E)	-72 degrees
Rollback angle, degrees (G)	44 degrees
Dump angle, ground	-150 degrees
Cycle times	---
Loader raise, seconds	3.1
Loader lower, seconds	2.1
Bucket dump, seconds	2.0
Bucket rollback, seconds	1.2

Specifications are based on published information at the time of publication. Specifications are subject to change without notice. Contact your local John Deere dealer for more information.

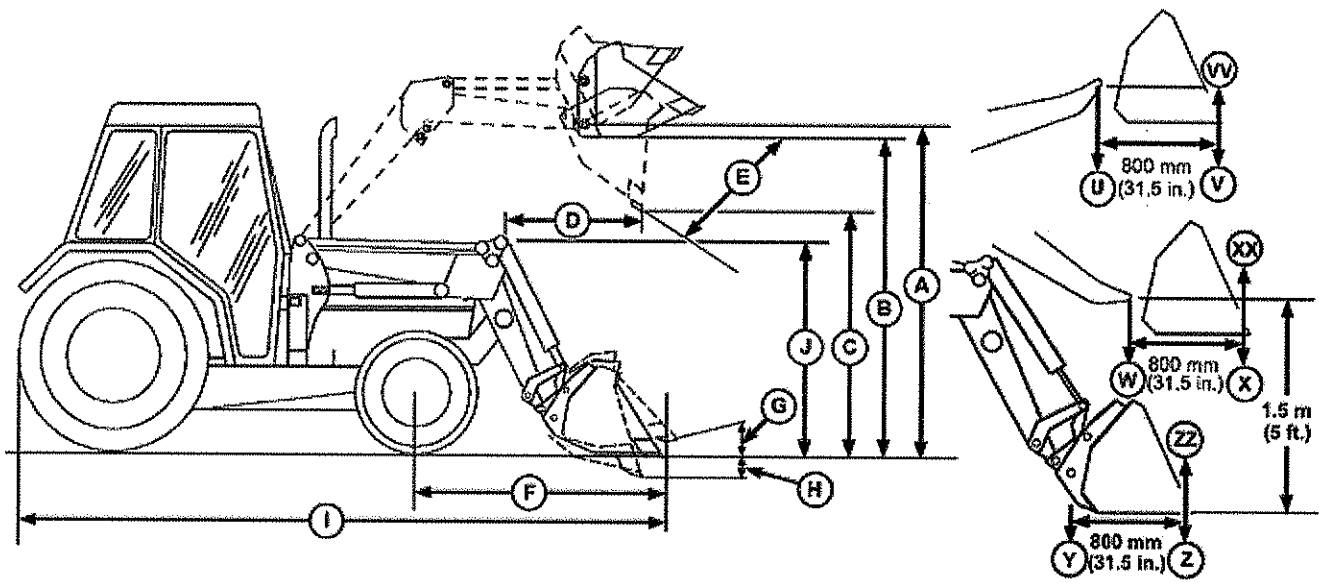



JOHN DEERE

MIDDLETOWN TRACTOR SALES

2345 Whitehall Blvd
FAIRMONT ,WV 26554
Phone: 304-366-4690
Fax: 304-366-4698



Quote Summary

Prepared For:
DEWAYNE O'DELL
304-558-2210

Prepared By:
STEPHEN M CRONIN
2345 Whitehall Blvd
FAIRMONT ,WV 26554
304-657-1636
STEVE@MIDDLETOWNTRACTOR.COM

Quote ID: 3653301
Created On: July 31, 2009
Last Modified On: August 8, 2009
Expiration Date: August 7, 2009

Equipment Summary	Suggested List	Selling Price	Qty	Extended
John Deere 5095 TRACTOR	\$ 63,393.16	\$ 45,133.57 X	1 =	\$ 45,133.57
John Deere 563 FARM LOADER	\$ 8,090.15	\$ 6,566.08 X	1 =	\$ 6,566.08
Equipment Total				\$ 51,699.65

Quote Summary

Equipment	\$ 51,699.65
Trade In	
Subtotal	\$ 51,699.65
Total	\$ 51,699.65
Down Payment	
Rental Applied	
Balance Due	\$ 51,699.65

Salesperson: X _____

Accepted By: X _____



Selling Equipment



John Deere 5095 TRACTOR

Suggested List
\$ 63,393.16
Selling Price
\$ 45,133.57

Description	Qty	Unit	Extended
5095M Utility Tractor	1	\$ 47,000.00	\$ 47,000.00
Standard Options - Per Unit			
MFWD (4 Wheel Drive)	1	\$ 0.00	
Cab	1	\$ 9,861.00	
Vertical Exhaust	1	\$ 0.00	
32F/16R PowrReverser Plus Transmission - 540/540E	1	\$ 2,595.00	
Electrohydraulic (EH) with remote LH fender control	1	\$ 399.00	
Dual Rear Valve with Lever Controls	1	\$ 0.00	
Dual Mid Valve with Joystick Control	1	\$ 0.00	
3-Point Hitch with Telescoping Draft Links	1	\$ 0.00	
16.9R34 147A8 R1W Radial	1	\$ 810.00	
13.6R24 125A8 R1W Radial	1	\$ 162.00	
Cold Weather Package	1	\$ 178.00	
Standard Options		\$ 14,005.00	
Standard Options Total	1		\$ 14,005.00
Dealer Options			
540/1000 PTO KIT (OCT-NOV)	1		\$ 1,500.00
Other Charges			
Delivery	1	\$ 250.00	
Setup	1	\$ 350.00	
Freight	1	\$ 288.16	
Discount	1		\$ -18,259.59
Total			\$ 45,133.57

John Deere 563 FARM LOADER

Suggested List
\$ 8,090.15
Selling Price
\$ 6,566.08

Description	Qty	Unit	Extended
-------------	-----	------	----------



JOHN DEERE

Selling Equipment



563 Non-Self-Leveling Loader	1	\$ 8,475.00	\$ 8,475.00
Standard Options - Per Unit			
Custom Configuration	1	\$ 0.00	
Mounting Frame	1	\$ -462.00	
2 Function - Hoses and Couplers	1	\$ -1,311.00	
Less Couplers	1	\$ -210.00	
Less Ballast Box	1	\$ 0.00	
Global Carrier	1	\$ 0.00	
Less Bucket	1	\$ -775.00	
85 In. (2150 mm) Global Materials Bucket	1	\$ 928.00	
Hood Guard	1	\$ 200.00	
Brush Guard	1	\$ 96.00	
Standard Options		\$ -1,534.00	
Standard Options Total	1		\$ -1,534.00
Dealer Options			
HORST BALE SPEAR	1		\$ 519.00
Other Charges			
Setup	1	\$ 350.00	
Freight	1	\$ 280.15	
Discount	1		\$ -1,524.07
Total			\$ 6,566.08

VENDOR PREFERENCE CERTIFICATE

Certification and application* is hereby made for Preference in accordance with *West Virginia Code*, §5A-3-37. (Does not apply to construction contracts). *West Virginia Code*, §5A-3-37, provides an opportunity for qualifying vendors to request (at the time of bid) preference for their residency status. Such preference is an evaluation method only and will be applied only to the cost bid in accordance with the *West Virginia Code*. This certificate for application is to be used to request such preference. The Purchasing Division will make the determination of the Resident Vendor Preference, if applicable.

- 1. Application is made for 2.5% resident vendor preference for the reason checked:
 Bidder is an individual resident vendor and has resided continuously in West Virginia for four (4) years immediately preceding the date of this certification; or,
 Bidder is a partnership, association or corporation resident vendor and has maintained its headquarters or principal place of business continuously in West Virginia for four (4) years immediately preceding the date of this certification; or 80% of the ownership interest of Bidder is held by another individual, partnership, association or corporation resident vendor who has maintained its headquarters or principal place of business continuously in West Virginia for four (4) years immediately preceding the date of this certification; or,
 Bidder is a nonresident vendor which has an affiliate or subsidiary which employs a minimum of one hundred state residents and which has maintained its headquarters or principal place of business within West Virginia continuously for the four (4) years immediately preceding the date of this certification; or,
- 2. Application is made for 2.5% resident vendor preference for the reason checked:
 Bidder is a resident vendor who certifies that, during the life of the contract, on average at least 75% of the employees working on the project being bid are residents of West Virginia who have resided in the state continuously for the two years immediately preceding submission of this bid; or,
- 3. Application is made for 2.5% resident vendor preference for the reason checked:
 Bidder is a nonresident vendor employing a minimum of one hundred state residents or is a nonresident vendor with an affiliate or subsidiary which maintains its headquarters or principal place of business within West Virginia employing a minimum of one hundred state residents who certifies that, during the life of the contract, on average at least 75% of the employees or Bidder's affiliate's or subsidiary's employees are residents of West Virginia who have resided in the state continuously for the two years immediately preceding submission of this bid; or,
- 4. Application is made for 5% resident vendor preference for the reason checked:
 Bidder meets either the requirement of both subdivisions (1) and (2) or subdivision (1) and (3) as stated above; or,
- 5. Application is made for 3.5% resident vendor preference who is a veteran for the reason checked:
 Bidder is an individual resident vendor who is a veteran of the United States armed forces, the reserves or the National Guard and has resided in West Virginia continuously for the four years immediately preceding the date on which the bid is submitted; or,
- 6. Application is made for 3.5% resident vendor preference who is a veteran for the reason checked:
 Bidder is a resident vendor who is a veteran of the United States armed forces, the reserves or the National Guard, if, for purposes of producing or distributing the commodities or completing the project which is the subject of the vendor's bid and continuously over the entire term of the project, on average at least seventy-five percent of the vendor's employees are residents of West Virginia who have resided in the state continuously for the two immediately preceding years.

Bidder understands if the Secretary of Revenue determines that a Bidder receiving preference has failed to continue to meet the requirements for such preference, the Secretary may order the Director of Purchasing to: (a) reject the bid; or (b) assess a penalty against such Bidder in an amount not to exceed 5% of the bid amount and that such penalty will be paid to the contracting agency or deducted from any unpaid balance on the contract or purchase order.

By submission of this certificate, Bidder agrees to disclose any reasonably requested information to the Purchasing Division and authorizes the Department of Revenue to disclose to the Director of Purchasing appropriate information verifying that Bidder has paid the required business taxes, provided that such information does not contain the amounts of taxes paid nor any other information deemed by the Tax Commissioner to be confidential.

Under penalty of law for false swearing (*West Virginia Code*, §61-5-3), Bidder hereby certifies that this certificate is true and accurate in all respects; and that if a contract is issued to Bidder and if anything contained within this certificate changes during the term of the contract, Bidder will notify the Purchasing Division in writing immediately.

Bidder: Middletown Tanacet Sales Signed: J.A. Boyer
 Date: 8-7-09 Title: VP

*Check any combination of preference consideration(s) indicated above, which you are entitled to receive.

STATE OF WEST VIRGINIA
Purchasing Division

PURCHASING AFFIDAVIT

VENDOR OWING A DEBT TO THE STATE:

West Virginia Code §5A-3-10a provides that: No contract or renewal of any contract may be awarded by the state or any of its political subdivisions to any vendor or prospective vendor when the vendor or prospective vendor or a related party to the vendor or prospective vendor is a debtor and the debt owed is an amount greater than one thousand dollars in the aggregate.

PUBLIC IMPROVEMENT CONTRACTS & DRUG-FREE WORKPLACE ACT:

If this is a solicitation for a public improvement construction contract, the vendor, by its signature below, affirms that it has a written plan for a drug-free workplace policy in compliance with Article 1D, Chapter 21 of the *West Virginia Code*. The vendor **must** make said affirmation with its bid submission. Further, public improvement construction contract may not be awarded to a vendor who does not have a written plan for a drug-free workplace policy in compliance with Article 1D, Chapter 21 of the *West Virginia Code* and who has not submitted that plan to the appropriate contracting authority in timely fashion. For a vendor who is a subcontractor, compliance with Section 5, Article 1D, Chapter 21 of the *West Virginia Code* may take place before their work on the public improvement is begun.

ANTITRUST:

In submitting a bid to any agency for the state of West Virginia, the bidder offers and agrees that if the bid is accepted the bidder will convey, sell, assign or transfer to the state of West Virginia all rights, title and interest in and to all causes of action it may now or hereafter acquire under the antitrust laws of the United States and the state of West Virginia for price fixing and/or unreasonable restraints of trade relating to the particular commodities or services purchased or acquired by the state of West Virginia. Such assignment shall be made and become effective at the time the purchasing agency tenders the initial payment to the bidder.

I certify that this bid is made without prior understanding, agreement, or connection with any corporation, firm, limited liability company, partnership or person or entity submitting a bid for the same materials, supplies, equipment or services and is in all respects fair and without collusion or fraud. I further certify that I am authorized to sign the certification on behalf of the bidder or this bid.

LICENSING:

Vendors must be licensed and in good standing in accordance with any and all state and local laws and requirements by any state or local agency of West Virginia, including, but not limited to, the West Virginia Secretary of State's Office, the West Virginia Tax Department, West Virginia Insurance Commission, or any other state agencies or political subdivision. Furthermore, the vendor must provide all necessary releases to obtain information to enable the Director or spending unit to verify that the vendor is licensed and in good standing with the above entities.

CONFIDENTIALITY:

The vendor agrees that he or she will not disclose to anyone, directly or indirectly, any such personally identifiable information or other confidential information gained from the agency, unless the individual who is the subject of the information consents to the disclosure in writing or the disclosure is made pursuant to the agency's policies, procedures and rules. Vendor further agrees to comply with the Confidentiality Policies and Information Security Accountability Requirements, set forth in <http://www.state.wv.us/admin/purchase/privacy/noticeConfidentiality.pdf>.

Under penalty of law for false swearing (*West Virginia Code* §61-5-3), it is hereby certified that the vendor affirms and acknowledges the information in this affidavit and is in compliance with the requirements as stated.

Vendor's Name: Middletown Tractor Sales

Authorized Signature: J. Boyer VP Date: 8-7-09