



State of West Virginia  
 Department of Administration  
 Purchasing Division  
 2019 Washington Street East  
 Post Office Box 50130  
 Charleston, WV 25305-0130

**Request for  
 Quotation**

RFQ NUMBER  
**ABCA167**

PAGE  
**1**

ADDRESS CORRESPONDENCE TO ATTENTION OF  
**SHELLY MURRAY  
 304-558-8801**

POSTER

**Caliber Equipment, Inc.**  
 11482 Fox Cross Road  
 Asland, VA 23005

SHIP TO

**ALCOHOL BEVERAGE CONTROL  
 COMMISSION  
 322 70TH STREET, S.E.  
 CHARLESTON, WV  
 25304-2900 558-2487**

DATE PRINTED <b>06/02/2010</b>	TERMS OF SALE	SHIP VIA <b>Ground</b>	FOB <b>Factory</b>	FREIGHT TERMS <b>#750.00</b>
BID OPENING DATE: <b>06/17/2010</b>		BID OPENING TIME <b>01:30PM</b>		

LINE	QUANTITY	UOP	CAT NO	ITEM NUMBER	UNIT PRICE	AMOUNT
RE-BID OF ABCA126						
THE WEST VIRGINIA PURCHASING DIVISION, FOR THE AGENCY, THE WEST VIRGINIA ALCOHOL BEVERAGE CONTROL ADMINISTRATION, IS SOLICITING BIDS FOR A SWEEPER/ SCRUBBER PER THE ATTACHED SPECIFICATIONS.						
0001	1	LS		365-50	<i>Factory Ctr XR Rider Scrubber Sweeper</i> \$19,069.00	<i>See attached Spec info</i> \$19,819.00
SHIP TO		: ALCOHOL BEVERAGE CONTROL COMMISSION HUB INDUSTRIAL PARK RIVER ROAD NITRO, WV 25143 558-2487				
<p>CANCELLATION: THE DIRECTOR OF PURCHASING RESERVES THE RIGHT TO CANCEL THIS CONTRACT IMMEDIATELY UPON WRITTEN NOTICE TO THE VENDOR IF THE COMMODITIES AND/OR SERVICES SUPPLIED ARE OF AN INFERIOR QUALITY OR DO NOT CONFORM WITH THE SPECIFICATIONS OF THE BID AND CONTRACT HEREIN.</p> <p>BANKRUPTCY: IN THE EVENT THE VENDOR/CONTRACTOR FILES FOR BANKRUPTCY PROTECTION, THIS CONTRACT IS AUTOMATICALLY NULL AND VOID, AND IS TERMINATED WITHOUT FURTHER ORDER.</p>						
NOTICE						

SEE REVERSE SIDE FOR TERMS AND CONDITIONS

SIGNATURE <i>J. Smith</i>	TELEPHONE <b>804-798-4333</b>	DATE <b>6/14/10</b>
TITLE <i>VP Sales</i>	FEIN <b>541785279</b>	ADDRESS CHANGES TO BE NOTED ABOVE

WHEN RESPONDING TO RFQ, INSERT NAME AND ADDRESS IN SPACE ABOVE LABELED 'VENDOR'



State of West Virginia  
 Department of Administration  
 Purchasing Division  
 2019 Washington Street East  
 Post Office Box 50130  
 Charleston, WV 25305-0130

# Request for Quotation

RFQ NUMBER  
**ABCA167**

PAGE  
**2**

ADDRESS CORRESPONDENCE TO ATTENTION OF  
**SHELLY MURRAY**  
**304-558-8801**

RFQ COPY  
 TYPE NAME/ADDRESS HERE

ALCOHOL BEVERAGE CONTROL  
 COMMISSION  
 322 70TH STREET, S.E.  
 CHARLESTON, WV  
 25304-2900 558-2487

DATE PRINTED	TERMS OF SALE	SHIP VIA	F.O.B.	FREIGHT TERMS
06/02/2010				

BID OPENING DATE: **06/17/2010** BID OPENING TIME **01:30PM**

LINE	QUANTITY	UOP	CAT NO	ITEM NUMBER	UNIT PRICE	AMOUNT
<p>A SIGNED BID MUST BE SUBMITTED TO:</p> <p>DEPARTMENT OF ADMINISTRATION            PURCHASING DIVISION            BUILDING 15            2019 WASHINGTON STREET, EAST            CHARLESTON, WV 25305-0130</p> <p>THE BID SHOULD CONTAIN THIS INFORMATION ON THE FACE OF THE ENVELOPE OR THE BID MAY NOT BE CONSIDERED:</p> <p>SEALED BID</p> <p>BUYER: SHELLY MURRAY</p> <p>RFQ. NO.: ABCA167</p> <p>BID OPENING DATE: 06/17/2010</p> <p>BID OPENING TIME: 1:30 PM</p> <p>PLEASE PROVIDE A FAX NUMBER IN CASE IT IS NECESSARY TO CONTACT YOU REGARDING YOUR BID:  <i>804-798-4335</i></p> <p>CONTACT PERSON (PLEASE PRINT CLEARLY):  <i>DAVE BOOTH</i></p>						

SEE REVERSE SIDE FOR TERMS AND CONDITIONS

SIGNATURE: *[Signature]* TELEPHONE: *804-798-4335* DATE: *6/14/10*

TITLE: *VP Sales* FEIN: *541785279* ADDRESS CHANGES TO BE NOTED ABOVE

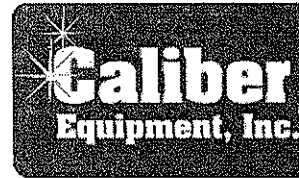

11482 Fox Cross Rd.  
Ashland, VA 23005

June 15, 2010

State Of West Virginia  
Department of Administration  
Purchasing Division  
2019 Washington Street East  
Charleston, WV 25305  
RFQ# ABCA167

Attn: Shelly Murray;

Caliber Equipment Inc., distributor of industrial scrubber machines and sweepers, submits the following product proposal for your consideration:  
A Factory Cat model **XR** riding floor scrubber - now available in both 34" and 40" scrub paths. The **XR** riding floor scrubber machine provides new choices in both durability and productivity by reproducing the rugged construction previously seen in the Factory Cat predecessors. These rider scrubbers increase your productivity by carrying more cleaning solution than other rider scrubbers in this larger scrub path size range. Keeping the operator at task increases your overall efficiency, and increasing the cleaning solution volume generates longer run times between refills. Choose a disk style scrub deck for floor scrubbing, or a cylindrical style scrub deck for both wet sweeping of light debris and floor scrubbing.

**Machines Include:**

- "Central Command II" Energy Management System
- 3.0HP All-Gear Front Wheel Drive
- 65-Gallon Polyethylene Solution Tank with Solution Level Indicator
- 65-Gallon Polyethylene Recovery Tank with 2" Drain Hose
- Disk: Two 1.0 HP 265 RPM Direct Gear Drive Brush Motors, with (2) brushes (any fiber)
- Cylindrical: Two 1.5 HP / 350 rpm Scrub Motors, with (2) brushes (any fiber)
- Dual (650 Watt) 3-Stage Vacuum Motor
- 7-Gage (3/16") All-Steel Frame
- Powder Paint Finish--16 times more corrosion resistant than enamel
- Automatic brush pressure control, with 5 settings from 0 to 350 lbs.
- 36 volt / 325 AH Battery Pack, and 36 amp (110-v / 60 Hz) fully automatic charger
- L.C.D. readout for trouble shooting with diagnostic codes
- L.C.D. readout for solution flow, brush pressure, battery gauge, & (3) hour meters.
- Horn, Back-Up Alarm & Dual Headlights
- Low Solution and High Recovery Warning Lights
- Operator & Parts Manual & Nearly 100% Stainless Steel Fasteners
- Heavy Duty Tires (Front and Rear) for Chemical Resistance
- Rear Bumper with Rollers

New Floor Scrubbers and Sweepers \* Used and Refurbished Equipment  
Distributor of American Lincoln, Nilfisk Advance, and Factory Cat  
Long and Short Term Rentals \* OEM replacement Parts  
Comprehensive Maintenance Service \* Cleaning Chemicals.



11482 Fox Cross Rd.  
Ashland, VA 23005

**Productivity features:**

- Operator productivity improves when you require fewer trips across the facility to fill and dump solution tanks. The **large 65 gallon solution tanks** offered on the XR offer you 50% more capacity than the 42 or 45 gallons seen on competitor machines. Model XR solution tanks will increase operator time actually scrubbing by 50% over similar scrub path model floor scrubbers. Ultimately the operator will require less time to complete the task. This lowers your total costs.
- High down pressure, more vacuum than competing machines. **Performance matters!**
- A large battery pack allows you to have an extended run time. Staff your machine for a full shift if required.

Part #	Factory Cat Rider Scrubber Sweeper	Regular Price	Discounted Price
370-			
34FC	XR-34" Cylindrical Rider	\$19,848.00	\$17,869.00
370-			
429	Front Sidebroom System	\$1,280.00	\$ 1,152.00
48-24	Seat Belt	\$55.00	\$ 48.00

**Total Machine Price \$19,069.00**

**Factory warranty:** 3 years parts and 1 year labor.  
10 year tanks One month dealer travel.

Terms: Net 30 days with your written purchase order.  
F.O.B. Factory - allow \$750.00  
Delivery: Allow 3-4 weeks  
VA Sales tax will not be added.  
**Local installation and service included.**

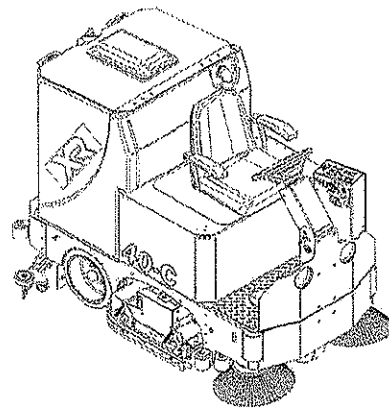

For Caliber Equipment Inc.;  
**Dave Booth**  
VP of Sales  
804-798-4333  
Calibereq@aol.com

**New Floor Scrubbers and Sweepers \* Used and Refurbished Equipment**  
**Distributor of American Lincoln, Nilfisk Advance, and Factory Cat**  
**Long and Short Term Rentals \* OEM replacement Parts**  
**Comprehensive Maintenance Service \* Cleaning Chemicals.**

Request for Quotation  
WEST VIRGINIA ALCOHOL CONTROL ADMINISTRATION  
Sweeper-Scrubber Unit  
Requisition Number:  
ABCA167

1.0 **Scope:**

1.1 The specifications are intended to cover all requirements for the purchase of a Scrubber-Sweeper system to be used at the West Virginia Alcohol Beverage Control Administration, Warehouse located in Nitro, WV.

2.0 **Specifications:**

- 2.1 Successful bidder, hereafter "Supplier" shall furnish a scrubber-sweeper, all necessary attachments and delivery of said unit to the WVABCA Warehouse. The "Supplier" shall provide the following specifications on the aforementioned unit:
- 2.1.1 Must have a minimum cleaning path of 32 inches (including side and sweeping brush).
  - 2.1.2 Is to have no more than four cylindrical brushes and no less than two.
  - 2.1.3 Shall possess the ability to place down pressure on the brushes to allow more pressure to be applied on desired spots.
  - 2.1.4 Shall be equipped with a side sweeping brush.
  - 2.1.5 Shall be equipped with a squeegee that is equipped with a breakaway feature.
  - 2.1.6 Shall be equipped with a system that raises the squeegee when the unit is placed in reverse.
  - 2.1.7 Shall allow the operator to control the amount of water used to scrub or squeegee.
  - 2.1.8 Shall be capable of picking up small debris such as wood chips, glass fragments, paper and plastic fragments.
  - 2.1.9 Shall be capable of scrubbing and dry sweeping.
  - 2.1.10 Must have a minimum of 36 volt battery system and must come equipped with a battery charger.
  - 2.1.11 Must be equipped with an hour meter and battery discharge meter.
  - 2.1.12 Shall have fuse protection on its circuitry.
  - 2.1.13 Shall have an adjustable seat and a seatbelt.
  - 2.1.14 The driver's seat shall be mounted at the front portion of the scrubber-sweeper to allow for maximum line of sight by the driver.
  - 2.1.15 Shall have a solution tank with a minimum capacity of 40 gallons.
  - 2.1.16 Shall have a recovery tank with a minimum capacity of 50 gallons.

- 2.1.17 Shall have drain valves that allow for hose connections on the solution and recovery tanks. The connections will allow the operator to fill and empty the aforementioned tanks.
- 2.1.18 Shall be equipped with a dust filter that may be changed with minimal tools.
- 2.1.19 Shall have a debris hopper that is equipped with a minimum of 70 pounds of capacity.
- 2.1.20 Shall be equipped with hazard lights that may be engaged while the unit is in motion.
- 2.1.21 Shall be accompanied by a parts manual and an operations manual.
- 2.1.22 The "Supplier" must deliver the scrubber-sweeper to the WVABCA Warehouse located at 500 River Road, Hub Industrial Park, Nitro, WV 25143. Delivery costs must be included in the price of the equipment.
- 2.1.23 Equipment cost must be inclusive of manufacturer's warranty.

### 3.0 Submitting:

- 3.1 The Vendor should submit the following with bid proposals but must submit prior to award:
  - 3.1.1 Manufacturer's warranty, specifications on all items, operation and maintenance manuals.

### 4.0 Acceptance and Testing Requirements:

- 4.1.1 Upon delivery of the scrubber-sweeper the "Supplier" shall demonstrate the units functions and demonstrate that the equipment is in working order prior to acceptance by the agency. Warranty period will become effective upon agency acceptance via change order.

RFQ No. ABCA167

STATE OF WEST VIRGINIA  
Purchasing Division

**PURCHASING AFFIDAVIT**

**West Virginia Code §5A-3-10a states:** No contract or renewal of any contract may be awarded by the state or any of its political subdivisions to any vendor or prospective vendor when the vendor or prospective vendor or a related party to the vendor or prospective vendor is a debtor and the debt owed is an amount greater than one thousand dollars in the aggregate.

**DEFINITIONS:**

"Debt" means any assessment, premium, penalty, fine, tax or other amount of money owed to the state or any of its political subdivisions because of a judgment, fine, permit violation, license assessment, defaulted workers' compensation premium, penalty or other assessment presently delinquent or due and required to be paid to the state or any of its political subdivisions, including any interest or additional penalties accrued thereon.

"Debtor" means any individual, corporation, partnership, association, limited liability company or any other form or business association owing a debt to the state or any of its political subdivisions. "Political subdivision" means any county commission; municipality; county board of education; any instrumentality established by a county or municipality; any separate corporation or instrumentality established by one or more counties or municipalities, as permitted by law; or any public body charged by law with the performance of a government function or whose jurisdiction is coextensive with one or more counties or municipalities. "Related party" means a party, whether an individual, corporation, partnership, association, limited liability company or any other form or business association or other entity whatsoever, related to any vendor by blood, marriage, ownership or contract through which the party has a relationship of ownership or other interest with the vendor so that the party will actually or by effect receive or control a portion of the benefit, profit or other consideration from performance of a vendor contract with the party receiving an amount that meets or exceed five percent of the total contract amount.

**EXCEPTION:** The prohibition of this section does not apply where a vendor has contested any tax administered pursuant to chapter eleven of this code, workers' compensation premium, permit fee or environmental fee or assessment and the matter has not become final or where the vendor has entered into a payment plan or agreement and the vendor is not in default of any of the provisions of such plan or agreement.

Under penalty of law for false swearing (*West Virginia Code* §61-5-3), it is hereby certified that the vendor affirms and acknowledges the information in this affidavit and is in compliance with the requirements as stated.

**WITNESS THE FOLLOWING SIGNATURE**

Vendor's Name: Caliber Equipment

Authorized Signature: David Smith Date: 6/15/10

State of VIRGINIA

County of HANOVER, to-wit:

Taken, subscribed, and sworn to before me this 15<sup>th</sup> day of JUNE, 2010.

My Commission expires July 31, 2013

AFFIX SEAL HERE

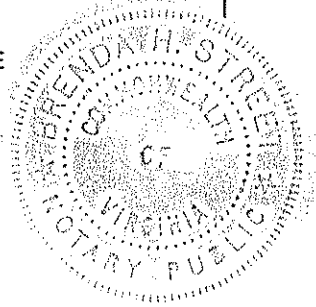

NOTARY PUBLIC Brenda A. Street

# FACTORY CAT

MADE IN U.S.A.

# XR Series Rider Scrubbers

**Caliber**  
Equipment, Inc.

11482 Fox Cross Rd.  
Ashland, VA 23005

<http://caliberequipment.com>

Toll Free 888-550-0945

Industrial Floor Cleaning Machines & Supplies

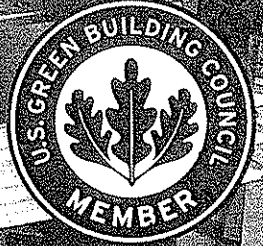

## FAMILY OF INDUSTRIAL CLEANING EQUIPMENT (17" - 48")

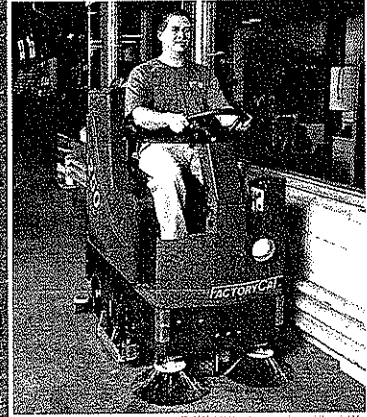



## FACTORY CAT XR SCRUBBERS

These rugged and high performance scrubbers offer the productivity of the industry's largest equipment, but in a more maneuverable package.

With two specialized cleaning systems and five deck sizes to choose from, **FACTORY CATS XRs** offer the results and capacity required to clean your unique application.

The "Disk" XRs offer gimballed brush drive and 45% more scrubbing power than competitive brands. The "Cylindrical" units reduce or eliminate dust mopping, by sweeping and scrubbing in a single pass.

The scrub decks include adjustable wipers and curtains, for unmatched water control. All components are made of heavy gauge steel for durability and accessibility is designed in to simplify service work.

## PRODUCTIVITY

Productivity is a function of scrub path, run time and tank capacity, and **FACTORY CATS** top the chart.

1. Larger Tanks (68 gallons) = Less stopping to refill
2. Wider Scrub Path (46") = Fewer trips down the aisle
3. High Down Pressure = Less double scrubbing
4. Twin Vacuum Motors = Dry, safe, clean floors
5. Big Battery = Runs a full shift

## EASY TO SERVICE

Any manufacturer can claim to build equipment that is both tough and easy to clean up, but we actually do and invite you to compare other equipment. Your maintenance staff will notice the difference immediately.

### Tank Tips

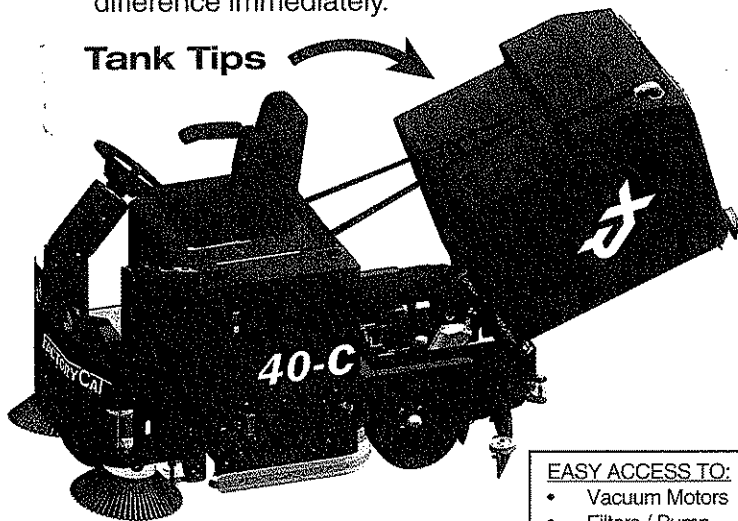

#### EASY ACCESS TO:

- Vacuum Motors
- Filters / Pump
- Valves
- Actuators

FREE DEMO (800) 634-4060

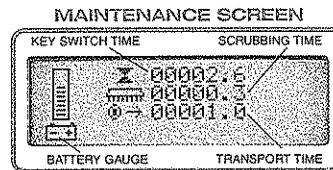

Large Lid Complete Access to Clean

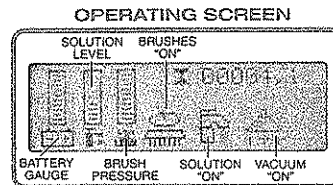

Large Tanks (68 gallons) Increased Productivity

Massive Steel Frame Durability in HD Applications

Heavy Duty Tires Optimum Stability & Traction

Oversized Motors Superior Cleaning & Long Lasting

Disk Decks Excellent VCT Performance

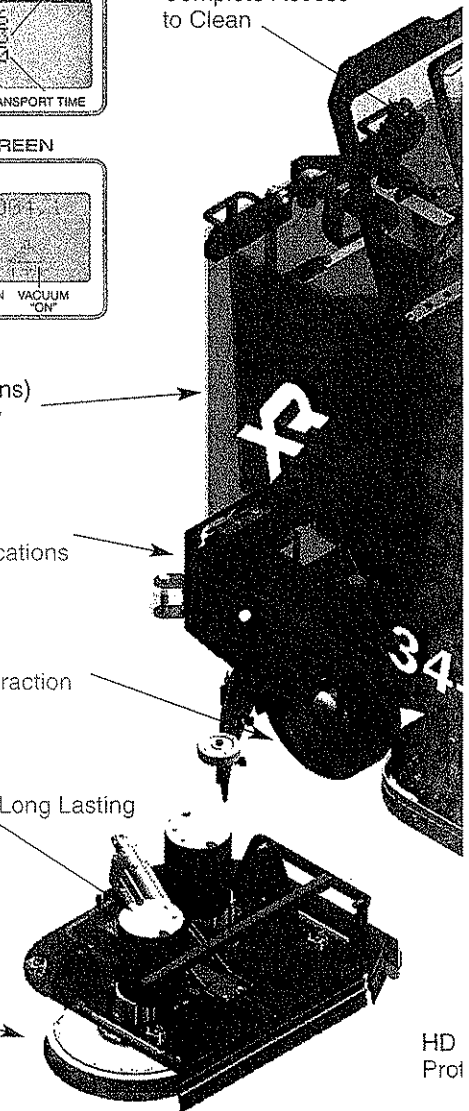

RS

## ERGONOMIC DESIGN

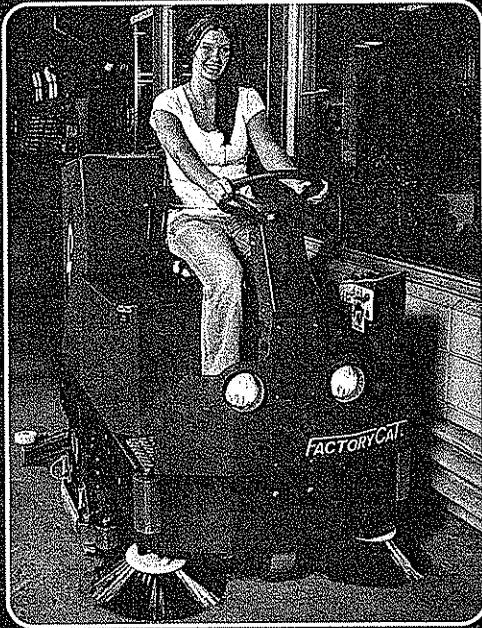
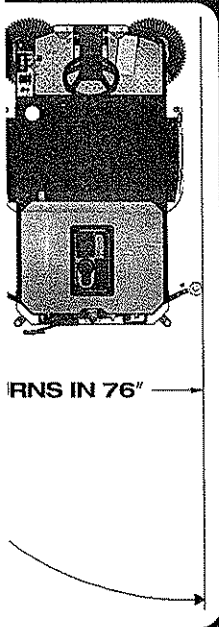

## FACTORY CAT XR SCRUBBERS

The operator sits in a spring-suspension, fully adjustable, mid-back chair. The adjustable steering column, armrests, and front guard further enhance operator comfort and safety. With a powerful drive motor, these machines can climb steep ramps, and come standard with heavy duty tires. Features include an automatic parking brake, and reduction of transport speed while scrubbing or backing up.

Our Central Command II system includes an LCD readout, on-board diagnostics, and three hour meters, simplifying preventive maintenance intervals. When the batteries discharge, the machine automatically shuts down all systems except "transport" to allow you to return to the charge station or any standard 20A outlet with the optional onboard charger.

## BUILT TOUGH

**FACTORY CATS** use powerful motors, which typically run at only 50% of their capacity. This leaves power in reserve for times where heavy scrubbing is required, and prolongs motor life.

- Constructed of thick steel, and powder-painted to prevent corrosion.
- Tanks have extra-thick walls and brass inserts for strength.
- Tall polyurethane rollers disperse collision forces without leaving marks on your walls.
- **FACTORY CATS** use only stainless fasteners.

Drain Saver  
Keeps Debris Out of Drains

Adjustable Seat & Steering  
Operator Comfort

Big Batteries  
Extended Run Time

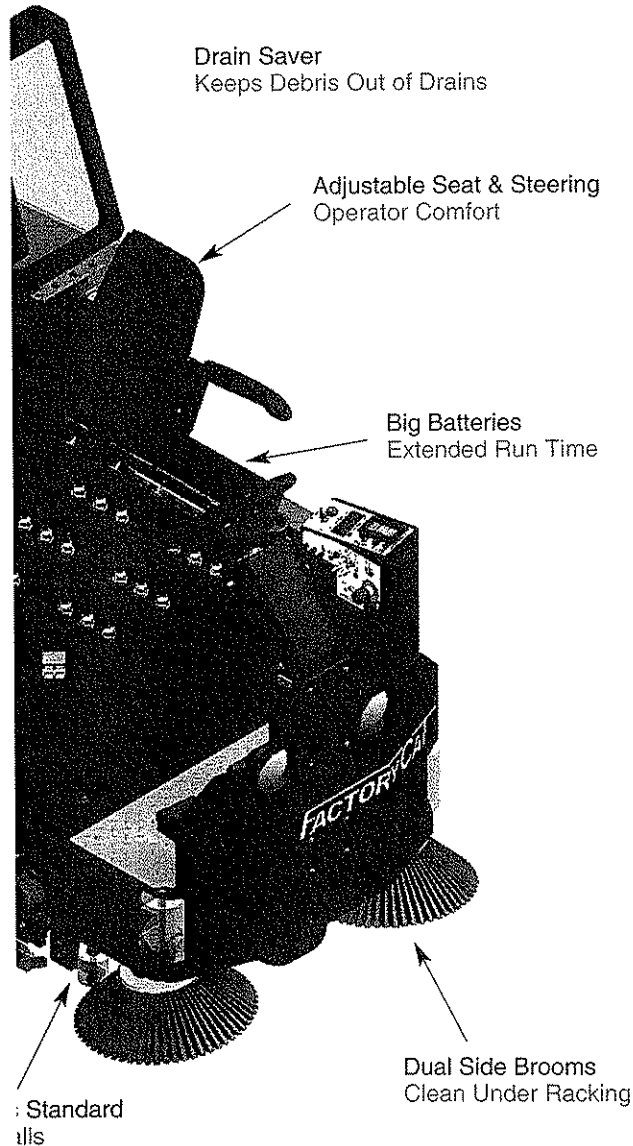

Dual Side Brooms  
Clean Under Racking

## POPULAR OPTIONS

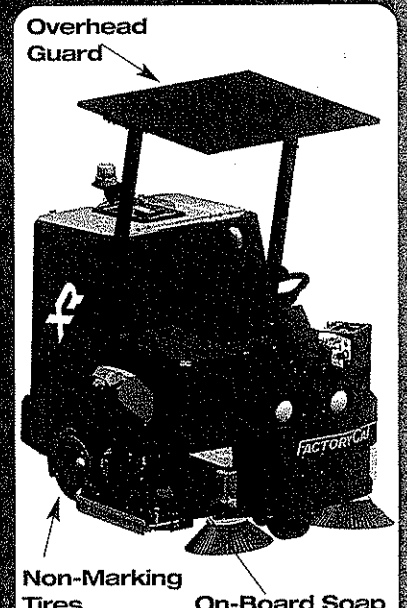
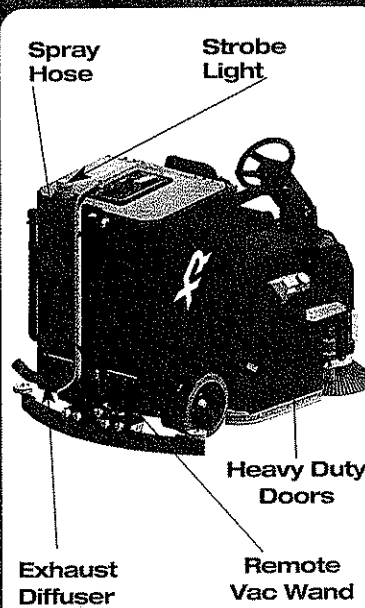

## EXPERIENCED DISTRIBUTORS

**FACTORY CAT** continues to grow by providing the toughest machines in our industry, at a reasonable investment. Our 300 distributors each maintain a factory-trained service department and diverse rental fleet, which allow them to continue serving your needs.

We offer a line of cleaning equipment that includes sweepers and scrubbers in both walk-behind and rider models. All **FACTORY CAT** machines are practical, rugged and sensibly priced. We can happily provide leasing information to those customers who prefer it.

Quality chemicals are a vital component to any cleaning program, so feel free to contact us with questions about "Approved" chemicals for use in our equipment.

## GUARANTEED SERVICE

We guarantee to supply you the spare parts you need within three workdays, or they are yours free. This applies only to the 48 contiguous states, at the customer's special request, and to parts that can be shipped by courier.

## AUTHORIZED DISTRIBUTOR

**Manufactured By:**  
**R.P.S. Corporation**  
**P.O. Box 368 • Racine, WI 53401; USA**  
**Phone: (800) 634-4060**  
**Fax: (866) 901-3335**  
**[www.factorycat.com](http://www.factorycat.com)**

Copyright R.P.S. Corporation 2007. All rights reserved. Since our policy is one of constant improvement, all specifications are subject to change without notice.

## Body Construction/Dimensions

Tank Material:	Poly (3/8" thick)
Frame Construction:	7-gauge (3/16" Steel)
Rear Wheels (diameter x width):	14" x 5"
Drive Wheel (diameter x width):	12" x 4"
Size (L x W x H):	69" x 36" x 56"
Weight:	1,230 pounds
Weight (w / batteries):	1,950 pounds

## Brush/Pad System

Brush Down Pressure:	0-350 pounds
Brush Pressure Settings:	(5) w / auto adjust

## DISK

Brush / Pad Size:	370-34D: (2) 17" 370-40D: (2) 20"
Brush Speed:	270-rpm
Motor Power:	(2) 1.5 hp

## CYLINDRICAL

Brush Size:	370-34C: (2) 32" x 7" 370-40C: (2) 38" x 7" 370-46C: (2) 44" x 7"
Brush Speed	750-rpm
Motor Power:	(2) 1.5 hp

## Battery System

Battery AH Rating (standard):	(Qty 6) 325 AH
Battery AH Rating (optional):	(Qty 6) 395 AH
Battery AH Rating (Industrial Battery):	(Qty 1) 440 AH / 1,245 lbs.
Battery Run Time	Up to 6 hours
Charger (110-v / 60 hz, auto):	36-v / 36-amp

## Solution System

Solution Tank Capacity:	68-gallons
Solution Flow Rate:	0-1.5 gpm
Solution Filter:	Inline Stainless

## Recovery System

Recovery Tank Capacity:	68-gallons
Vacuum Power	1.6 hp
Vacuum (lift / airflow)	68" / 140 cfm
Demisting Chamber:	2.5 gallons

## Drive System

Power:	3.0 hp, sealed
Type:	All Gear
Speed Control:	0-5 mph

## General

Sound Levels:	71 dBA
Side Boom Path:	45"
Cleaning Width / Productivity:	370-34: 34"/36,720 sq. ft./hr. 370-40: 40"/43,200 sq. ft./hr. 370-46: 46"/49,680 sq. ft./hr.

## Optional Equipment

• Maintenance Free Batteries	• Onboard Soap
• Spray Hose	• Onboard Charger
• Vacuum Wand	• Non-Marking Tires
• Side Brooms	• HD Package (Side Doors)
• Industrial Battery (440 ah)	• Overhead Guard
• 85 Gallon Stainless Tanks	• Variety of Brushes and Squeegees
• Removable Battery System	