



State of West Virginia
 Department of Administration
 Purchasing Division
 2019 Washington Street East
 Post Office Box 50130
 Charleston, WV 25305-0130

Request for Quotation

RFQ NUMBER
ABCA167

PAGE
1

ADDRESS CORRESPONDENCE TO ATTENTION OF
SHELLY MURRAY
304-558-8801

VENDOR

Caliber Equipment, Inc.
 11482 Fox Cross Road
 Asland, VA 23005

SHIP TO

ALCOHOL BEVERAGE CONTROL
COMMISSION
322 70TH STREET, S.E.
CHARLESTON, WV
25304-2900 558-2487

DATE PRINTED	TERMS OF SALE	SHIP VIA	F.O.B	FREIGHT TERMS
06/02/2010	30 DAY NET	GROUND	FACTORY	\$750.00
BID OPENING DATE: 06/17/2010		BID OPENING TIME: 01:30PM		

LINE	QUANTITY	UOP	CAT NO	ITEM NUMBER	UNIT PRICE	AMOUNT
0001	1	LS		365-50	\$35,432.50	\$36,182.50
<p>RE-BID OF ABCA126</p> <p>THE WEST VIRGINIA PURCHASING DIVISION, FOR THE AGENCY, THE WEST VIRGINIA ALCOHOL BEVERAGE CONTROL ADMINISTRATION, IS SOLICITING BIDS FOR A SWEEPER/ SCRUBBER PER THE ATTACHED SPECIFICATIONS.</p> <p><i>Advance 7730 Sweeper Scrubber see attached spec sheet</i></p> <p>SHIP TO : ALCOHOL BEVERAGE CONTROL COMMISSION HUB INDUSTRIAL PARK RIVER ROAD NITRO, WV 25143 558-2487</p> <p>CANCELLATION: THE DIRECTOR OF PURCHASING RESERVES THE RIGHT TO CANCEL THIS CONTRACT IMMEDIATELY UPON WRITTEN NOTICE TO THE VENDOR IF THE COMMODITIES AND/OR SERVICES SUPPLIED ARE OF AN INFERIOR QUALITY OR DO NOT CONFORM WITH THE SPECIFICATIONS OF THE BID AND CONTRACT HEREIN.</p> <p>BANKRUPTCY: IN THE EVENT THE VENDOR/CONTRACTOR FILES FOR BANKRUPTCY PROTECTION, THIS CONTRACT IS AUTOMATICALLY NULL AND VOID, AND IS TERMINATED WITHOUT FURTHER ORDER.</p> <p>NOTICE</p>						

RECEIVED

2010 JUN 16 P 12:23

PURCHASING DIVISION
 STATE OF WV

SEE REVERSE SIDE FOR TERMS AND CONDITIONS

SIGNATURE <i>[Signature]</i>	TELEPHONE 804-798-4333	DATE 6/14/10
TITLE VP Sales	FEIN 541785279	ADDRESS CHANGES TO BE NOTED ABOVE

WHEN RESPONDING TO RFQ, INSERT NAME AND ADDRESS IN SPACE ABOVE LABELED 'VENDOR'



State of West Virginia
 Department of Administration
 Purchasing Division
 2019 Washington Street East
 Post Office Box 50130
 Charleston, WV 25305-0130

**Request for
 Quotation**

RFQ NUMBER
ABCA167

PAGE
2

ADDRESS CORRESPONDENCE TO ATTENTION OF
**SHELLY MURRAY
 304-558-8801**

RFQ COPY
 TYPE NAME/ADDRESS HERE

V
E
N
D
O
R

S
H
I
P
I
O

**ALCOHOL BEVERAGE CONTROL
 COMMISSION
 322 70TH STREET, S.E.
 CHARLESTON, WV
 25304-2900 558-2487**

DATE PRINTED	TERMS OF SALE	SHIP VIA	FOB	FREIGHT TERMS
06/02/2010				

BID OPENING DATE: **06/17/2010** BID OPENING TIME **01:30PM**

LINE	QUANTITY	UOP	CAT NO	ITEM NUMBER	UNIT PRICE	AMOUNT
<p>A SIGNED BID MUST BE SUBMITTED TO:</p> <p>DEPARTMENT OF ADMINISTRATION PURCHASING DIVISION BUILDING 15 2019 WASHINGTON STREET, EAST CHARLESTON, WV 25305-0130</p> <p>THE BID SHOULD CONTAIN THIS INFORMATION ON THE FACE OF THE ENVELOPE OR THE BID MAY NOT BE CONSIDERED:</p> <p>SEALED BID</p> <p>BUYER: SHELLY MURRAY</p> <p>RFQ. NO.: ABCA167</p> <p>BID OPENING DATE: 06/17/2010</p> <p>BID OPENING TIME: 1:30 PM</p> <p>PLEASE PROVIDE A FAX NUMBER IN CASE IT IS NECESSARY TO CONTACT YOU REGARDING YOUR BID: <i>804-798-4335</i></p> <p>CONTACT PERSON (PLEASE PRINT CLEARLY): <i>DAVE Booth</i></p>						

SEE REVERSE SIDE FOR TERMS AND CONDITIONS

SIGNATURE	TELEPHONE	DATE
TITLE	FEIN	ADDRESS CHANGES TO BE NOTED ABOVE

State of West Virginia
 Department of Administration
 Purchasing Division
 2019 Washington Street east
 Charleston, WV 25305
 RFQ# ABCA167

Dave Booth
 Caliber Equipment VP of Sales
 11482 Fox Cross Rd.
 Ashland, VA 23005
 Phone 804-798-4333
 Fax 804-798-4335
 Email Calibereq@aol.com

June 15, 2010

**ADVANCE
 SC7730
 RIDER SWEEPER/SCRUBBER
 PROPOSAL/ORDER**

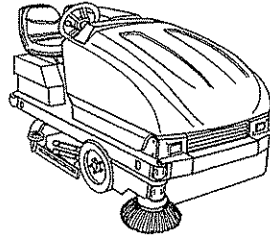

Standard Equipment Includes

- * 46" Sweep Path
- * 40 or 46" Scrub Path
- * Tilt Steering Wheel
- * No-Tool Broom, Brush and Panel Filter Removal
- * High Recovery and Low Solution Indicator Lights
- * Dual Electric 3-Stage Radial Discharge Vac Fan
- * Fully Adjustable Seat with Operator Presence Sensor
- * Auto Solution and Brushes Off In Neutral
- * Traction drive controller w/dynamic braking
- * Ultra-Web® Nanofiber Technology Dust Filter
- * 55 gal. Solution and Recovery Tanks
- * 2.5 cu. ft. Hopper
- * 90/90 Power Steering
- * Battery Condition Meter
- * Accu-Track™ Break-Away Squeegee
- * Electronic Unidirectional Foot Pedal
- * Auto Squeegee Lift in Reverse
- * Low Battery Shutdown System
- * Electronic Linear Solution Control
- * 2000 Watt Drive Motor

Warranty

- * 8 Years on Rotomold Components
- * 3 Years/2,000 hrs Parts
- * 2 Years Labor/6 Months Travel
- * 1 Year Vac Fan Motor

PART #	DESCRIPTION	Regular Rprice	QTY	Discounted Price
56 515 856	SC7730 40" with 720Ah Battery (0775-224), 3 Phase Charger (0775-235), Proex and Wire Main Broom (8-08-03141), Poly Side Broom and 2 Clean Grit Brushes (0765-274)	\$43,200.00	1	\$35,217.00
56 515 857	SC7730 46" with 720Ah Battery (0775-224), 3 Phase Charger (0775-235), Proex and Wire Main Broom (8-08-03141), Poly Side Broom and 3 Clean Grit Brushes (0765-265)	\$44,400.00		\$ -

MAIN BROOM

8-08-03137	6DR, Proex Main Broom	\$242.00	\$	-
8-08-03141	6DR, Proex & Wire Main Broom	\$316.50	\$	-
8-08-03142	6DR, Nylon Main Broom	\$329.00	\$	-

SIDE BROOMS

8-08-03215	Polypropylene Side Broom (standard)	\$201.00	\$	-
------------	-------------------------------------	----------	----	---

20" ONE PIECE DISC BRUSHES & PAD DRIVERS FOR 40" VERSION (2 req)

0765-271	Black Nylon	\$228.50	\$	-
0765-272	Polypropylene .040	\$179.00	\$	-
0765-273	Supergrit	\$406.50	\$	-
0765-274	Clean Grit (standard on 40" model)	\$443.50	\$	-
0780-497	Pad Driver Assembly	\$357.50	\$	-

16" ONE PIECE DISC BRUSHES & PAD DRIVERS FOR 46" VERSION (3 req)

0765-256	Black Nylon	\$194.50	\$	-
0765-257	Polypropylene .040 One Piece Disc Scrub Brush	\$137.50	\$	-
0765-258	Supergrit One Piece Disc Scrub Brush	\$335.00	\$	-
0765-265	Clean Grit (standard on 46" model)	\$324.50	\$	-
0780-434	Pad Driver Assembly	\$244.00	\$	-

BATTERIES AND CHARGERS

0775-224	(1) 36V, 720 Ah, Wet Battery (standard)	\$10,813.00	\$	-
0775-235	240 Vac, Three Phase, 60 Hz, 36 Vdc, 150A, 8 Hour Charger Time Charger for 720 Ah Battery (standard)	\$4,299.00	\$	-

REAR SQUEEGEES

7-77-00130	Linatex Rear Squeegee		\$	-
------------	-----------------------	--	----	---

PANEL FILTER

8-24-04074-1	Nanofiber Coated Cellulose (standard on dust control models)	\$71.00	\$	-
8-24-04074-2	UltraWeb™ Water Resistant Filter	\$210.50	\$	-

ADDITIONAL FEATURES

0780-584	Back Up Alarm	\$625.50	\$	-
0780-482	Fire Extinguisher	\$199.50	\$	-
56 515 827	Amber Strobe Light without OHG	\$480.50	\$	-
56 515 826	Amber Strobe Light on OHG (must order 0780-476)	\$431.00	\$	-
0780-591	Headlights and Taillight	\$507.50	\$	-
0780-493	Seat Belt	\$215.50	1 \$	215.50
56 515 825	Overhead Guard	\$1,383.00	\$	-
0780-592	Spray & Vac Wand	\$2,232.00	\$	-
0780-429	Squeegee Wand	\$473.50	\$	-
7-03-04250	Arm Rest (RH only)	\$42.50	\$	-
0780-697	Smart Cart, Self Supporting	\$1,964.50	\$	-
0780-698	Bumpers, Four Corner Roller	\$1,790.00	\$	-

EXTENDED WARRANTY (from in-service date)

2-86-00296	3 Years/3,000 Hours Parts and Labor (in lieu of standard)	\$2,177.00	\$	-
2-86-00297	4 Years/4,000 Hours Parts and Labor (in lieu of standard)	\$3,242.00	\$	-

SPECIAL ITEMS

_____	\$	-
_____	\$	-
_____	\$	-
_____	\$	-
_____	\$	-

<i>Applied Discount %</i>	\$	-
<i>Applied Discount \$</i>	\$	-
<i>Machine Sub Total</i>	\$	-
<i>Miscellaneous</i>	\$	-
<i>Freight</i>	\$	750.00
<i>Tax</i>	\$	-
<i>Machine Total</i>	\$	36,182.50

Special Instructions:

Terms and Conditions

Prices subject to change without notice.
 Terms:
 Freight: FOB shipping point Prepaid and Add
 All terms and conditions are subject to change and credit review.

Request for Quotation
WEST VIRGINIA ALCOHOL CONTROL ADMINISTRATION
Sweeper-Scrubber Unit
Requisition Number:
ABCA167

1.0 **Scope:**

1.1 The specifications are intended to cover all requirements for the purchase of a Scrubber-Sweeper system to be used at the West Virginia Alcohol Beverage Control Administration, Warehouse located in Nitro, WV.

2.0 **Specifications:**

- 2.1 Successful bidder, hereafter "Supplier" shall furnish a scrubber-sweeper, all necessary attachments and delivery of said unit to the WVABCA Warehouse. The "Supplier" shall provide the following specifications on the aforementioned unit:
- 2.1.1 Must have a minimum cleaning path of 32 inches (including side and sweeping brush).
 - 2.1.2 Is to have no more than four cylindrical brushes and no less than two.
 - 2.1.3 Shall possess the ability to place down pressure on the brushes to allow more pressure to be applied on desired spots.
 - 2.1.4 Shall be equipped with a side sweeping brush.
 - 2.1.5 Shall be equipped with a squeegee that is equipped with a breakaway feature.
 - 2.1.6 Shall be equipped with a system that raises the squeegee when the unit is placed in reverse.
 - 2.1.7 Shall allow the operator to control the amount of water used to scrub or squeegee.
 - 2.1.8 Shall be capable of picking up small debris such as wood chips, glass fragments, paper and plastic fragments.
 - 2.1.9 Shall be capable of scrubbing and dry sweeping.
 - 2.1.10 Must have a minimum of 36 volt battery system and must come equipped with a battery charger.
 - 2.1.11 Must be equipped with an hour meter and battery discharge meter.
 - 2.1.12 Shall have fuse protection on its circuitry.
 - 2.1.13 Shall have an adjustable seat and a seatbelt.
 - 2.1.14 The driver's seat shall be mounted at the front portion of the scrubber-sweeper to allow for maximum line of sight by the driver.
 - 2.1.15 Shall have a solution tank with a minimum capacity of 40 gallons.
 - 2.1.16 Shall have a recovery tank with a minimum capacity of 50 gallons.

- 2.1.17 Shall have drain valves that allow for hose connections on the solution and recovery tanks. The connections will allow the operator to fill and empty the aforementioned tanks.
- 2.1.18 Shall be equipped with a dust filter that may be changed with minimal tools.
- 2.1.19 Shall have a debris hopper that is equipped with a minimum of 70 pounds of capacity.
- 2.1.20 Shall be equipped with hazard lights that may be engaged while the unit is in motion.
- 2.1.21 Shall be accompanied by a parts manual and an operations manual.
- 2.1.22 The "Supplier" must deliver the scrubber-sweeper to the WVABCA Warehouse located at 500 River Road, Hub Industrial Park, Nitro, WV 25143. Delivery costs must be included in the price of the equipment.
- 2.1.23 Equipment cost must be inclusive of manufacturer's warranty.

3.0 **Submitting:**

- 3.1 The Vendor should submit the following with bid proposals but must submit prior to award:
 - 3.1.1 Manufacturer's warranty, specifications on all items, operation and maintenance manuals.

4.0 Acceptance and Testing Requirements:

- 4.1.1 Upon delivery of the scrubber-sweeper the "Supplier" shall demonstrate the units functions and demonstrate that the equipment is in working order prior to acceptance by the agency. Warranty period will become effective upon agency acceptance via change order.

RFQ No. ABCA167

STATE OF WEST VIRGINIA
Purchasing Division

PURCHASING AFFIDAVIT

West Virginia Code §5A-3-10a states: No contract or renewal of any contract may be awarded by the state or any of its political subdivisions to any vendor or prospective vendor when the vendor or prospective vendor or a related party to the vendor or prospective vendor is a debtor and the debt owed is an amount greater than one thousand dollars in the aggregate.

DEFINITIONS:

"Debt" means any assessment, premium, penalty, fine, tax or other amount of money owed to the state or any of its political subdivisions because of a judgment, fine, permit violation, license assessment, defaulted workers' compensation premium, penalty or other assessment presently delinquent or due and required to be paid to the state or any of its political subdivisions, including any interest or additional penalties accrued thereon.

"Debtor" means any individual, corporation, partnership, association, limited liability company or any other form or business association owing a debt to the state or any of its political subdivisions. "Political subdivision" means any county commission; municipality; county board of education; any instrumentality established by a county or municipality; any separate corporation or instrumentality established by one or more counties or municipalities, as permitted by law; or any public body charged by law with the performance of a government function or whose jurisdiction is coextensive with one or more counties or municipalities. "Related party" means a party, whether an individual, corporation, partnership, association, limited liability company or any other form or business association or other entity whatsoever, related to any vendor by blood, marriage, ownership or contract through which the party has a relationship of ownership or other interest with the vendor so that the party will actually or by effect receive or control a portion of the benefit, profit or other consideration from performance of a vendor contract with the party receiving an amount that meets or exceed five percent of the total contract amount.

EXCEPTION: The prohibition of this section does not apply where a vendor has contested any tax administered pursuant to chapter eleven of this code, workers' compensation premium, permit fee or environmental fee or assessment and the matter has not become final or where the vendor has entered into a payment plan or agreement and the vendor is not in default of any of the provisions of such plan or agreement.

Under penalty of law for false swearing (*West Virginia Code* §61-5-3), it is hereby certified that the vendor affirms and acknowledges the information in this affidavit and is in compliance with the requirements as stated.

WITNESS THE FOLLOWING SIGNATURE

Vendor's Name: Casper Equipment

Authorized Signature: [Signature] Date: 6/15/10

State of VIRGINIA

County of HANOYER, to-wit:

Taken, subscribed, and sworn to before me this 15th day of JUNE, 2010.

My Commission expires 7-31-2013, 20 .

AFFIX SEAL HERE

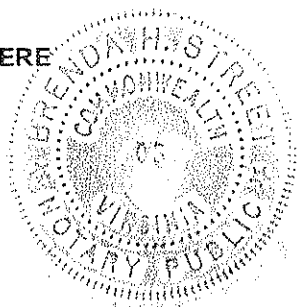

NOTARY PUBLIC [Signature]
#142491



11482 Fox Cross Rd.
Ashland, VA 23005

<http://caliberequipment.com>

Toll Free 888-550-0945

Industrial Floor Cleaning Machines & Supplies

7730

Battery Powered Rider Sweeper-Scrubber

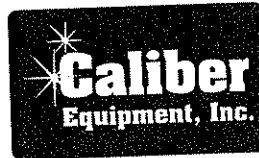

Floor Scrubbers & Sweepers
Maintenance Services
Cleaning Solutions
Long & Short Term Rentals

DAVE BOOTH
Vice President of Sales
www.caliberequipment.com

Toll Free (888) 550-0945
Fax (804) 798-4335
Cell (804) 357-0374

11482 Fox Cross Rd.
Ashland, VA 23005
Office (804) 798-4333

Smart cleaning.

A Nilfisk-Advance Brand

 **Advance**
Industrial Cleaning Equipment

Battery compartment offers easy access for daily maintenance.

Deeply padded seat, power steering and tilt steering wheel provide top-of-the-line comfort.

Corrosion-proof, impact-resistant polyethylene solution and recovery tanks protect your investment.

Dust control system prevents stirring up even the finest dust while sweeping.

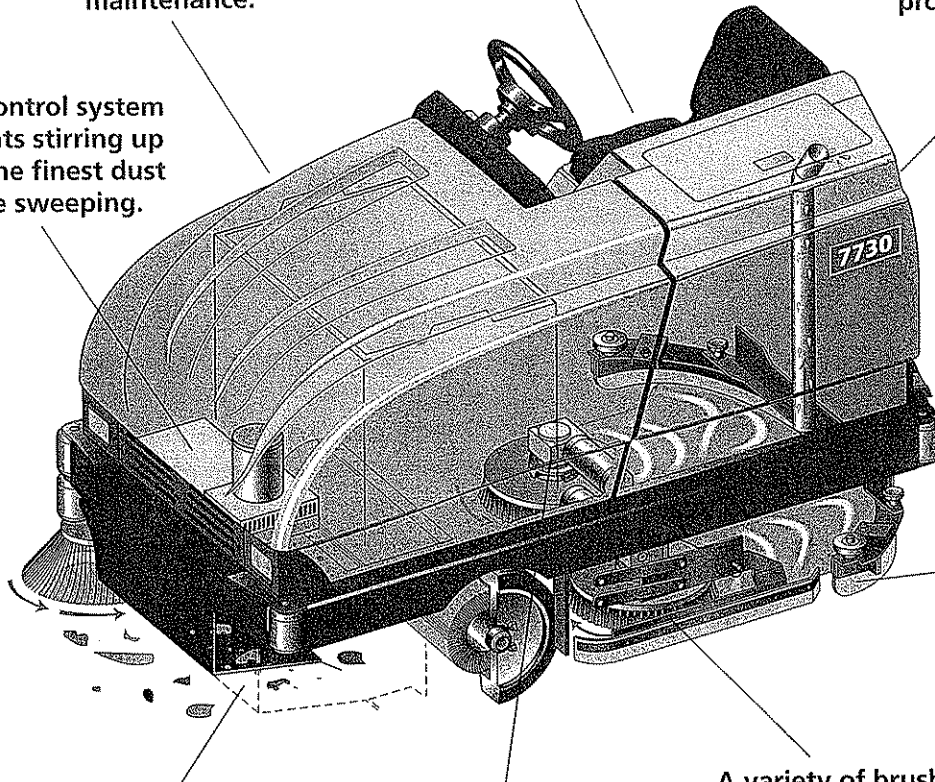

Accu-Track™ squeegee provides superior water pickup even during the tightest turns and with no-tool squeegee change, maintenance is a snap.

Independent dry sweeping system picks up dirt and debris before scrubbing.

A variety of brushes accommodates your cleaning needs.

Heavy-duty, high torque 1.7 h.p. brush drive motors aggressively clean the dirtiest floors.

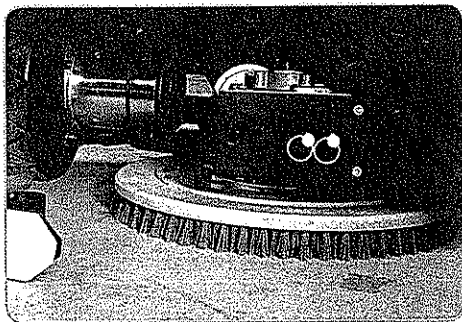

Double-scrub disc brushes offer the most aggressive cleaning action with quick, no-tool changing in minutes.

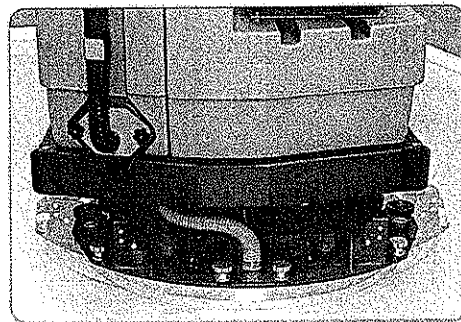

Accu-Track™ squeegee provides superior water pickup even during the tightest turns and no-tool changing for easy maintenance.



Large capacity batteries last for hours of cleaning and a quick and easy roll-on, roll-off battery changing system reduces downtime.

7730 Battery Powered Rider Sweeper-Scrubber

Reliable, Productive Sweeping and Scrubbing

The Advance 7730 is a powerful and reliable sweeper-scrubber that is sure to increase your cleaning productivity. This machine easily fits into small areas, yet with its large capacity hopper and solution tanks can clean up to 70,000 square feet per hour effortlessly. If you are looking for high-quality, efficient cleaning the 7730 offers both without the emissions and maintenance of an engine.

Innovative Key Features:

- Patented Accu-Track™ squeegee system leaves a clean, dry floor even in the tightest turns
- Dynamic, regenerative electric drive motor enhances reliability
- Standard roll-on, roll-off battery changing system offers increased productivity

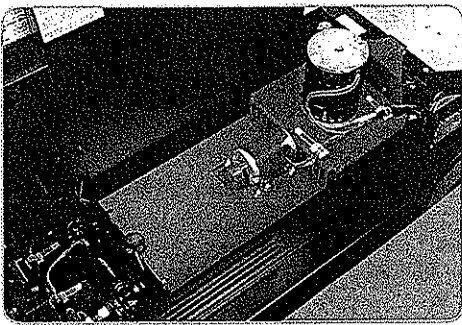

Dust control option provides dust-free sweeping before debris enters the scrubbing area.

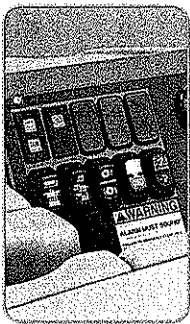

Reliable rocker switches and a tilt steering wheel result in easy-to-use controls and low maintenance costs.

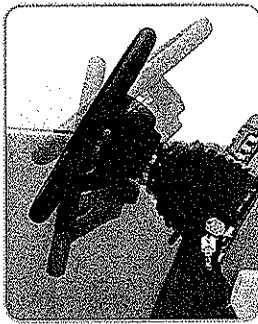

FEATURES AND BENEFITS

Productivity – Two machines in one – sweeper and scrubber. Powerful dust control system. Simple drain and clean-out system. Roll-on, roll-off battery change system. Powerful electric drive and power steering system. Large solution/recovery tanks to stay on the floor longer between cleanups. One-pass sweeping and scrubbing cleans up to 70,000 square feet per hour. Solution and brushes turn off when machine is not moving.

Durability – Sevcon traction drive controller. Heavy gauge welded steel chassis. Corrosion-proof Polydur® solution/recovery tanks. Accu-Track™ break-away squeegee. Durable corner roller bumpers for side protection.

Safety Features – Dead man seat with traction lockout. Controlled directional drive. Better handling with rack and pinion power steering. Excellent front and rear view for operator.



Ideal applications include:

- Manufacturing Plants
- Discount Warehouses
- Food Warehouses
- Parking Garages
- Automotive Plants



Advance

Industrial Cleaning Equipment

Technical Specifications

Model	7730
Sweep Path	36 in (91 cm) or 46 in (117 cm)
Hopper Capacity	2.5 ft ³ (71 L)
Scrub Path	40 in (101 cm) or 46 in (117 cm)
Brush Sizes	(2) 20 in (51 cm) or (3) 16 in (40.6 cm)
Brush Speed	210 rpm
Brush Motors	1.7 hp heavy-duty, angled gear motor
Solution Tank	55 gal (170 L)
Recovery Tank	55 gal (170 L)
Vacuum Motor (2)	1 hp, 3-stage tangential discharge
Transport Speed	0 – 4.6 mph (0 – 7.4 kph)
Cleaning Speed	0 – 2.7 mph (0 – 4.3 kph)
Drive Motor	2.7 hp (2,000 W)
Aisle U-turn	87 in (221 cm)
Size (LxWxH)	87 x 46 x 52 in (221 x 116.8 x 132 cm) squeegee width 48 in (122 cm)
Weight (w/o batteries)	1,700 lb (765 kg)

Specifications are subject to change without notice.

Standard Features:

- Powerful electric drive and power steering system
- Large solution/recovery tanks to stay on the floor longer between cleanups
- Sevcon traction drive controller
- Heavy gauge welded steel chassis
- Corrosion-proof Polydur[®] solution/recovery tanks
- Accu-Track[™] break-away squeegee
- Durable corner roller bumpers for side protection
- Dead man seat with traction lockout
- Controlled directional drive
- Rack and pinion power steering

14600 21st Avenue North
Plymouth, MN 55447-3408
www.advance-us.com
Phone 800-214-7700
Fax 800-989-6566

240 Superior Boulevard
Mississauga, Ontario, Canada L5T 2L2
www.niifisk-advance.com
Phone 800-668-8400
Fax 800-263-5111

Ask about our leasing options.

©2009 Nilfisk-Advance, Inc. Form L3100A 6-15-09



Mixed Sources

Product group from well-managed forests, controlled sources and recycled wood or fiber
www.fsc.org Cert no. SW-COC-002374
© 1996 Forest Stewardship Council



recyclable



Advance

Industrial Cleaning Equipment

www.advance-us.com/industrial

A Nilfisk-Advance Brand