



State of West Virginia
 Department of Administration
 Purchasing Division
 2019 Washington Street East
 Post Office Box 50130
 Charleston, WV 25305-0130

Request for Quotation

RFQ NUMBER
7010EC01

PAGE
1

ADDRESS CORRESPONDENCE TO ATTENTION OF
MICHAEL AUSTIN
304-558-2402

RFQ COPY
 TYPE NAME/ADDRESS HERE

Middletown Tractor Sales
 2345 Whitehall Boulevard
 Fairmont, WV 26554

DIVISION OF HIGHWAYS
 EQUIPMENT DIVISION
 ROUTE 33
 BRUSHY FORK ROAD
 BUCKHANNON, WV
 26201 304-472-1750

DATE PRINTED	TERMS OF SALE	SHIP VIA	FOB	FREIGHT TERMS
09/02/2009	Net 30 Days	Our Truck	Destination	Pre-Paid

BID OPENING DATE: **10/07/2009** BID OPENING TIME **01:30PM**

LINE	QUANTITY	UOP	CAT NO	ITEM NUMBER	UNIT PRICE	AMOUNT
0001	1	EA		550-96		\$ 6535. ¹⁵
<p>TO PROVIDE TRAILER MOUNTED SOLAR POWERED AAROWBOARD</p> <p>OPEN END CONTRACT</p> <p>TO PROVIDE TRAILER MOUNTED SOLAR POWERED ELECTRIC ARROWBOARDS FOR THE WEST VIRGINIA DIVISION OF HIGHWAYS PER THE ATTACHED SPECIFICATIONS.</p> <p>MANDATORY PRE-BID</p> <p>A MANDATORY PRE-BID WILL BE HELD ON 09/15/2009 AT 10:00 AM AT THE EQUIPMENT DIVISION BUCKHANNON, WV. ALL INTERESTED PARTIES ARE REQUIRED TO ATTEND THIS MEETING FAILURE TO ATTEND THE MANDATORY PRE-BID SHALL RESULT IN DISQUALIFICATION OF THE BID. NO ONE PERSON MAY REPRESENT MORE THAN ONE BIDDER.</p> <p>AN ATTENDANCE SHEET WILL BE MADE AVAILABLE FOR ALL POTENTIAL BIDDERS TO COMPLETE. THIS WILL SERVE AS THE OFFICIAL DOCUMENT VERIFYING ATTENDANCE AT THE MANDATORY PRE-BID. FAILURE TO PROVIDE YOUR COMPANY AND REPRESENTATIVE NAME ON THE ATTENDANCE SHEET WILL RESULT IN DISQUALIFICATION OF THE BID. THE STATE WILL NOT ACCEPT ANY OTHER DOCUMENTATION TO VERIFY ATTENDANCE. THE BIDDER IS RESPONSIBLE FOR ENSURING THEY HAVE COMPLETED THE INFORMATION REQUIRED ON THE ATTENDANCE SHEET. THE PURCHASING DIVISION AND THE STATE AGENCY WILL NOT ASSUME ANY RESPONSIBILITY FOR A BIDDER-S FAILURE TO COMPLETE THE PRE-BID ATTENDANCE SHEET. IN ADDITION, WE REQUEST THAT ALL POTENTIAL BIDDERS INCLUDE THEIR E-MAIL ADDRESS AND FAX NUMBER.</p>						

RECEIVED
 2009 OCT -7 A 10:14
 PURCHASING DIVISION
 STATE OF WV

SIGNATURE <i>Phillip A. Estabrook</i>		SEE REVERSE SIDE FOR TERMS AND CONDITIONS		TELEPHONE 304-366-4690	DATE 03 October 2009
TITLE Sales Consultant	FEIN 55-054-7175	ADDRESS CHANGES TO BE NOTED ABOVE			

WHEN RESPONDING TO RFQ, INSERT NAME AND ADDRESS IN SPACE ABOVE LABELED 'VENDOR'

GENERAL TERMS & CONDITIONS
REQUEST FOR QUOTATION (RFQ) AND REQUEST FOR PROPOSAL (RFP)

1. Awards will be made in the best interest of the State of West Virginia.
2. The State may accept or reject in part, or in whole, any bid.
3. All quotations are governed by the *West Virginia Code* and the *Legislative Rules* of the Purchasing Division.
4. Prior to any award, the apparent successful vendor must be properly registered with the Purchasing Division and have paid the required \$125 fee.
5. All services performed or goods delivered under State Purchase Order/Contracts are to be continued for the term of the Purchase Order/Contracts, contingent upon funds being appropriated by the Legislature or otherwise being made available. In the event funds are not appropriated or otherwise available for these services or goods, this Purchase Order/Contract becomes void and of no effect after June 30.
6. Payment may only be made after the delivery and acceptance of goods or services.
7. Interest may be paid for late payment in accordance with the *West Virginia Code*.
8. Vendor preference will be granted upon written request in accordance with the *West Virginia Code*.
9. The State of West Virginia is exempt from federal and state taxes and will not pay or reimburse such taxes.
10. The Director of Purchasing may cancel any Purchase Order/Contract upon 30 days written notice to the seller.
11. The laws of the State of West Virginia and the *Legislative Rules* of the Purchasing Division shall govern all rights and duties under the Contract, including without limitation the validity of this Purchase Order/Contract.
12. Any reference to automatic renewal is hereby deleted. The Contract may be renewed only upon mutual written agreement of the parties.
13. **BANKRUPTCY:** In the event the vendor/contractor files for bankruptcy protection, the State may deem this contract null and void, and terminate such contract without further order.
14. **HIPAA BUSINESS ASSOCIATE ADDENDUM:** The West Virginia State Government HIPAA Business Associate Addendum (BAA), approved by the Attorney General, and available online at the Purchasing Division's web site (<http://www.state.wv.us/admin/purchase/vrc/hipaa.htm>) is hereby made part of the agreement. Provided that, the Agency meets the definition of a Cover Entity (45 CFR §160.103) and will be disclosing Protected Health Information (45 CFR §160.103) to the vendor.
15. **WEST VIRGINIA ALCOHOL & DRUG-FREE WORKPLACE ACT:** If this Contract constitutes a public improvement construction contract as set forth in Article 1D, Chapter 21 of the West Virginia Code ("The West Virginia Alcohol and Drug-Free Workplace Act"), then the following language shall hereby become part of this Contract: "The contractor and its subcontractors shall implement and maintain a written drug-free workplace policy in compliance with the West Virginia Alcohol and Drug-Free Workplace Act, as set forth in Article 1D, Chapter 21 of the West Virginia Code. The contractor and its subcontractors shall provide a sworn statement in writing, under the penalties of perjury, that they maintain a valid drug-free work place policy in compliance with the West Virginia and Drug-Free Workplace Act. It is understood and agreed that this Contract shall be cancelled by the awarding authority if the Contractor: 1) Fails to implement its drug-free workplace policy; 2) Fails to provide information regarding implementation of the contractor's drug-free workplace policy at the request of the public authority; or 3) Provides to the public authority false information regarding the contractor's drug-free workplace policy."

INSTRUCTIONS TO BIDDERS

1. Use the quotation forms provided by the Purchasing Division.
2. **SPECIFICATIONS:** Items offered must be in compliance with the specifications. Any deviation from the specifications must be clearly indicated by the bidder. Alternates offered by the bidder as **EQUAL** to the specifications must be clearly defined. A bidder offering an alternate should attach complete specifications and literature to the bid. The Purchasing Division may waive minor deviations to specifications.
3. Complete all sections of the quotation form.
4. Unit prices shall prevail in case of discrepancy.
5. All quotations are considered F.O.B. destination unless alternate shipping terms are clearly identified in the quotation.
6. **BID SUBMISSION:** All quotations must be delivered by the bidder to the office listed below prior to the date and time of the bid opening. Failure of the bidder to deliver the quotations on time will result in bid disqualifications: Department of Administration, Purchasing Division, 2019 Washington Street East, P.O. Box 50130, Charleston, WV 25305-0130



State of West Virginia
 Department of Administration
 Purchasing Division
 2019 Washington Street East
 Post Office Box 50130
 Charleston, WV 25305-0130

Request for Quotation

RFQ NUMBER
 7010EC01

PAGE
 2

ADDRESS CORRESPONDENCE TO ATTENTION OF
 MICHAEL AUSTIN
 304-558-2402

RFQ COPY
 TYPE NAME/ADDRESS HERE

DIVISION OF HIGHWAYS
 EQUIPMENT DIVISION
 ROUTE 33
 BRUSHY FORK ROAD
 BUCKHANNON, WV
 26201 304-472-1750

DATE PRINTED	TERMS OF SALE	SHIP VIA	FOB	FREIGHT TERMS
09/02/2009				

BID OPENING DATE: 10/07/2009 BID OPENING TIME 01:30PM

LINE	QUANTITY	UOP	CAT. NO.	ITEM NUMBER	UNIT PRICE	AMOUNT
<p>ALL POTENTIAL BIDDERS ARE REQUESTED TO ARRIVE PRIOR TO THE STARTING TIME FOR THE PRE-BID. BIDDERS WHO ARRIVE LATE, BUT PRIOR TO THE DISMISSAL OF THE TECHNICAL PORTION OF THE PRE-BID WILL BE PERMITTED TO SIGN IN. BIDDERS WHO ARRIVE AFTER CONCLUSION OF THE TECHNICAL PORTION OF THE PRE-BID, BUT DURING ANY SUBSEQUENT PART OF THE PRE-BID WILL NOT BE PERMITTED TO SIGN THE ATTENDANCE SHEET.</p> <p>EXHIBIT 2</p> <p>LIFE OF CONTRACT: THIS CONTRACT BECOMES EFFECTIVE ON AND EXTENDS FOR A PERIOD OF ONE (1) YEAR OR UNTIL SUCH "REASONABLE TIME" THEREAFTER AS IS NECESSARY TO OBTAIN A NEW CONTRACT OR RENEW THE ORIGINAL CONTRACT. THE "REASONABLE TIME" PERIOD SHALL NOT EXCEED TWELVE (12) MONTHS. DURING THIS "REASONABLE TIME" THE VENDOR MAY TERMINATE THIS CONTRACT FOR ANY REASON UPON GIVING THE DIRECTOR OF PURCHASING THIRTY (30) DAYS WRITTEN NOTICE.</p> <p>UNLESS SPECIFIC PROVISIONS ARE STIPULATED IN THIS CONTRACT DOCUMENT, THE TERMS, CONDITIONS, AND PRICING SET HEREIN ARE FIRM FOR THE LIFE OF THE CONTRACT.</p> <p>RENEWAL: THIS CONTRACT MAY BE RENEWED UPON THE MUTUAL WRITTEN CONSENT OF THE SPENDING UNIT AND VENDOR, SUBMITTED TO THE DIRECTOR OF PURCHASING THIRTY (30) DAYS PRIOR TO THE EXPIRATION DATE. SUCH RENEWAL SHALL BE IN ACCORDANCE WITH THE TERMS AND CONDITIONS OF THE ORIGINAL CONTRACT AND SHALL BE LIMITED TO TWO (2) ONE (1) YEAR PERIODS.</p> <p>CANCELLATION: THE DIRECTOR OF PURCHASING RESERVES THE</p>						

SEE REVERSE SIDE FOR TERMS AND CONDITIONS.

SIGNATURE	TELEPHONE	DATE
TITLE	FEIN	ADDRESS CHANGES TO BE NOTED ABOVE

WHEN RESPONDING TO RFQ, INSERT NAME AND ADDRESS IN SPACE ABOVE LABELED 'VENDOR'



State of West Virginia
 Department of Administration
 Purchasing Division
 2019 Washington Street East
 Post Office Box 50130
 Charleston, WV 25305-0130

Request for Quotation

RFQ NUMBER
 7010EC01

PAGE
 3

ADDRESS CORRESPONDENCE TO ATTENTION OF
 MICHAEL AUSTIN
 304-558-2402

RFQ COPY
 TYPE NAME/ADDRESS HERE

VENDOR

SHIP TO

DIVISION OF HIGHWAYS
 EQUIPMENT DIVISION
 ROUTE 33
 BRUSHY FORK ROAD
 BUCKHANNON, WV
 26201 304-472-1750

DATE PRINTED 09/02/2009	TERMS OF SALE	SHIP VIA	F.O.B.	FREIGHT TERMS
BID OPENING DATE: 10/07/2009		BID OPENING TIME 01:30PM		

LINE	QUANTITY	UOP	CAT NO.	ITEM NUMBER	UNIT PRICE	AMOUNT
<p>RIGHT TO CANCEL THIS CONTRACT IMMEDIATELY UPON WRITTEN NOTICE TO THE VENDOR IF THE COMMODITIES AND/OR SERVICES SUPPLIED ARE OF AN INFERIOR QUALITY OR DO NOT CONFORM WITH THE SPECIFICATIONS OF THE BID AND CONTRACT HEREIN.</p> <p>OPEN MARKET CLAUSE: THE DIRECTOR OF PURCHASING MAY AUTHORIZE A SPENDING UNIT TO PURCHASE ON THE OPEN MARKET, WITHOUT THE FILING OF A REQUISITION OR COST ESTIMATE, ITEMS SPECIFIED ON THIS CONTRACT FOR IMMEDIATE DELIVERY IN EMERGENCIES DUE TO UNFORESEEN CAUSES (INCLUDING BUT NOT LIMITED TO DELAYS IN TRANSPORTATION OR AN UNANTICIPATED INCREASE IN THE VOLUME OF WORK).</p> <p>QUANTITIES: QUANTITIES LISTED IN THE REQUISITION ARE APPROXIMATIONS ONLY, BASED ON ESTIMATES SUPPLIES BY THE STATE SPENDING UNIT. IT IS UNDERSTOOD AND AGREED THAT THE CONTRACT SHALL COVER THE QUANTITIES ACTUALLY ORDERED FOR DELIVERY DURING THE TERM OF CONTRACT, WHETHER MORE OR LESS THAN THE QUANTITIES SHOWN.</p> <p>ORDERING PROCEDURE: SPENDING UNIT(S) SHALL ISSUE A WRITTEN EQUIPMENT CONTRACT ORDER (FORM NUMBER WV-35) FOR COMMODITIES COVERED BY THIS CONTRACT. THE ORIGINAL WV-35 MUST BE SENT TO THE PURCHASING DIVISION OF THE DEPARTMENT OF ADMINISTRATION. AFTER APPROVAL AND ENCUMBRANCE, ONE COPY OF THE PURCHASE ORDER WILL BE RETURNED TO THE SPENDING UNIT AND ONE COPY FORWARDED TO THE VENDOR AS AUTHORIZATION FOR SHIPMENT. NO ORDER IS VALID UNLESS APPROVED AND ENCUMBERED BY THE PURCHASING DIVISION.</p> <p>BANKRUPTCY: IN THE EVENT THE VENDOR/CONTRACTOR FILES FOR BANKRUPTCY PROTECTION, THE STATE MAY DEEM THE CONTRACT NULL AND VOID, AND TERMINATE SUCH CONTRACT WITHOUT FUTHER ORDER.</p>						

SEE REVERSE SIDE FOR TERMS AND CONDITIONS

SIGNATURE	TELEPHONE	DATE
TITLE	FEIN	ADDRESS CHANGES TO BE NOTED ABOVE

WHEN RESPONDING TO RFQ, INSERT NAME AND ADDRESS IN SPACE ABOVE LABELED 'VENDOR'



State of West Virginia
 Department of Administration
 Purchasing Division
 2019 Washington Street East
 Post Office Box 50130
 Charleston, WV 25305-0130

Request for Quotation

RFQ NUMBER
 7010EC01

PAGE
 4

ADDRESS CORRESPONDENCE TO ATTENTION OF:
 MICHAEL AUSTIN
 304-558-2402

RFQ COPY
 TYPE NAME/ADDRESS HERE

VENDOR

SHIP TO

DIVISION OF HIGHWAYS
 EQUIPMENT DIVISION
 ROUTE 33
 BRUSHY FORK ROAD
 BUCKHANNON, WV
 26201 304-472-1750

DATE PRINTED	TERMS OF SALE	SHIP VIA	F.O.B.	FREIGHT TERMS
09/02/2009				

BID OPENING DATE: 10/07/2009 BID OPENING TIME 01:30PM

LINE	QUANTITY	UOP	CAT NO	ITEM NUMBER	UNIT PRICE	AMOUNT
	REV. 5/2009					
<p>PURCHASING CARD ACCEPTANCE: THE STATE OF WEST VIRGINIA CURRENTLY UTILIZES A VISA PURCHASING CARD PROGRAM WHICH IS ISSUED THROUGH A BANK. THE SUCCESSFUL VENDOR MUST ACCEPT THE STATE OF WEST VIRGINIA VISA PURCHASING CARD FOR PAYMENT OF ALL ORDERS PLACED BY ANY STATE AGENCY AS A CONDITION OF AWARD.</p>						
<p>EXHIBIT 4</p>						
<p>LOCAL GOVERNMENT BODIES: UNLESS THE VENDOR INDICATES IN THE BID HIS REFUSAL TO EXTEND THE PRICES, TERMS, AND CONDITIONS OF THE BID TO COUNTY, SCHOOL, MUNICIPAL AND OTHER LOCAL GOVERNMENT BODIES, THE BID SHALL EXTEND TO POLITICAL SUBDIVISIONS OF THE STATE OF WEST VIRGINIA. IF THE VENDOR DOES NOT WISH TO EXTEND THE PRICES, TERMS, AND CONDITIONS OF THE BID TO ALL POLITICAL SUBDIVISIONS OF THE STATE, THE VENDOR MUST CLEARLY INDICATE SUCH REFUSAL IN HIS BID. SUCH REFUSAL SHALL NOT PREJUDICE THE AWARD OF THIS CONTRACT IN ANY MANNER.</p>						
<p>REV. 3/88</p>						
<p>EXHIBIT 6</p>						
<p>PRICE ADJUSTMENT PROVISION: THE STATE OF WEST VIRGINIA WILL CONSIDER BIDS THAT CONTAIN PROVISIONS FOR PRICE ADJUSTMENTS PRIOR TO THE ORIGINAL EXPIRATION OF THE CONTRACT, PROVIDED THAT</p>						

SEE REVERSE SIDE FOR TERMS AND CONDITIONS

SIGNATURE	TELEPHONE	DATE
TITLE	FEIN	ADDRESS CHANGES TO BE NOTED ABOVE

WHEN RESPONDING TO RFQ, INSERT NAME AND ADDRESS IN SPACE ABOVE LABELED 'VENDOR'



State of West Virginia
 Department of Administration
 Purchasing Division
 2019 Washington Street East
 Post Office Box 50130
 Charleston, WV 25305-0130

Request for Quotation

RFQ NUMBER
7010EC01

PAGE
5

ADDRESS CORRESPONDENCE TO ATTENTION OF
MICHAEL AUSTIN
304-558-2402

RFQ COPY
 TYPE NAME/ADDRESS HERE

VENDOR

SHIP TO

DIVISION OF HIGHWAYS
 EQUIPMENT DIVISION
 ROUTE 33
 BRUSHY FORK ROAD
 BUCKHANNON, WV
 26201
 304-472-1750

DATE PRINTED	TERMS OF SALE	SHIP VIA	FOB	FREIGHT TERMS
09/02/2009				

BID OPENING DATE: **10/07/2009** BID OPENING TIME **01:30PM**

LINE	QUANTITY	UOP	CAT NO.	ITEM NUMBER	UNIT PRICE	AMOUNT
<p>SUCH PRICE ADJUSTMENT COVERS BOTH UPWARD AND DOWNWARD MOVEMENT OF THE COMMODITY PRICE, AND THAT ADJUSTMENT IS BASED ON THE "PASS THROUGH" INCREASE OR DECREASE OF RAW MATERIALS AND/OR LABOR, WHICH MAKE UP ALL OR A SUBSTANTIAL PART OF A PRODUCT. ADJUSTMENTS ARE TO BE BASED UPON AN ACTUAL DOLLAR FIGURE, NOT A PERCENTAGE. ALL PRICE ADJUSTMENT REQUESTS MUST BE SUBSTANTIATED IN A MANNER ACCEPTABLE TO THE DIRECTOR PURCHASING, E.G. GOVERNMENTAL BENCH MARKS, GENERAL MARKET INCREASE, PUBLISHED PRICE LISTS. SUCH REQUESTS FOR AN INCREASE SHOULD BE RECEIVED IN WRITING BY THE DIRECTOR OF PURCHASING AT LEAST 30 DAYS IN ADVANCE OF THE EFFECTIVE DATE OF THE INCREASE. ANY TIME THE VENDOR REQUESTS A PRICE ADJUSTMENT, THE PURCHASING DIVISION MAY EITHER ACCEPT THE PRICE ADJUSTMENT AND AMEND THE CONTRACT ACCORDINGLY OR REJECT THE ADJUSTMENT IN ITS ENTIRETY AND CANCEL THE CONTRACT.</p> <p>EXHIBIT 10</p> <p style="text-align: right;">REQUISITION NO.: 7010EC01.....</p> <p>ADDENDUM ACKNOWLEDGEMENT</p> <p>I HEREBY ACKNOWLEDGE RECEIPT OF THE FOLLOWING CHECKED ADDENDUM(S) AND HAVE MADE THE NECESSARY REVISIONS TO MY PROPOSAL, PLANS AND/OR SPECIFICATION, ETC.</p> <p>ADDENDUM NO.'S:</p> <p>NO. 1 <input checked="" type="checkbox"/></p> <p>NO. 2</p> <p>NO. 3</p>						

SEE REVERSE SIDE FOR TERMS AND CONDITIONS			
SIGNATURE	TELEPHONE	DATE	
TITLE	FEIN	ADDRESS CHANGES TO BE NOTED ABOVE	

WHEN RESPONDING TO RFQ, INSERT NAME AND ADDRESS IN SPACE ABOVE LABELED 'VENDOR'



State of West Virginia
 Department of Administration
 Purchasing Division
 2019 Washington Street East
 Post Office Box 50130
 Charleston, WV 25305-0130

Request for Quotation

BFO NUMBER
7010EC01

PAGE
6

ADDRESS CORRESPONDENCE TO ATTENTION OF
**MICHAEL AUSTIN
 304-558-2402**

VENDOR

RFQ COPY
 TYPE NAME/ADDRESS HERE

SHIP TO

DIVISION OF HIGHWAYS
 EQUIPMENT DIVISION
 ROUTE 33
 BRUSHY FORK ROAD
 BUCKHANNON, WV
 26201 304-472-1750

DATE PRINTED	TERMS OF SALE	SHIP VIA	FOB	FREIGHT TERMS
09/02/2009				

BID OPENING DATE: **10/07/2009** BID OPENING TIME **01:30PM**

LINE	QUANTITY	UOP	CAT NO	ITEM NUMBER	UNIT PRICE	AMOUNT
NO. 4					
NO. 5					
<p>I UNDERSTAND THAT FAILURE TO CONFIRM THE RECEIPT OF TH ADDENDUM(S) MAY BE CAUSE FOR REJECTION OF BIDS.</p> <p>VENDOR MUST CLEARLY UNDERSTAND THAT ANY VERBAL REPRESENTATION MADE OR ASSUMED TO BE MADE DURING ANY ORAL DISCUSSION HELD BETWEEN VENDOR'S REPRESENTATIVES AND ANY STATE PERSONNEL IS NOT BINDING. ONLY THE INFORMATION ISSUED IN WRITING AND ADDED TO THE SPECIFICATIONS BY AN OFFICIAL ADDENDUM IS BINDING.</p> <p style="text-align: center;">  SIGNATURE Middletown Tractor Sales COMPANY 03 October 2009 DATE </p> <p>REV. 11/96</p> <p style="text-align: center;">NOTICE</p> <p>A SIGNED BID MUST BE SUBMITTED TO:</p> <p style="text-align: center;">DEPARTMENT OF ADMINISTRATION PURCHASING DIVISION BUILDING 15</p>						

SEE REVERSE SIDE FOR TERMS AND CONDITIONS

SIGNATURE	TELEPHONE	DATE
TITLE	FEIN	ADDRESS CHANGES TO BE NOTED ABOVE

WHEN RESPONDING TO RFQ, INSERT NAME AND ADDRESS IN SPACE ABOVE LABELED 'VENDOR'



State of West Virginia
 Department of Administration
 Purchasing Division
 2019 Washington Street East
 Post Office Box 50130
 Charleston, WV 25305-0130

Request for Quotation

RFQ NUMBER:
7010EC01

PAGE:
7

ADDRESS CORRESPONDENCE TO ATTENTION OF:
MICHAEL AUSTIN
304-558-2402

RFQ COPY
 TYPE NAME/ADDRESS HERE

DIVISION OF HIGHWAYS
EQUIPMENT DIVISION
ROUTE 33
BRUSHY FORK ROAD
BUCKHANNON, WV
26201 **304-472-1750**

DATE PRINTED	TERMS OF SALE	SHIP VIA	FOB	FREIGHT TERMS
09/02/2009				

BID OPENING DATE: **10/07/2009** BID OPENING TIME **01:30PM**

LINE	QUANTITY	UOP	CAT. NO.	ITEM NUMBER	UNIT PRICE	AMOUNT
2019 WASHINGTON STREET, EAST CHARLESTON, WV 25305-0130						
THE BID SHOULD CONTAIN THIS INFORMATION ON THE FACE OF THE ENVELOPE OR THE BID MAY NOT BE CONSIDERED:						
SEALED BID						
BUYER:				33		
RFQ. NO.:				7010EC01		
BID OPENING DATE:						
BID OPENING TIME:						
PLEASE PROVIDE A FAX NUMBER IN CASE IT IS NECESSARY TO CONTACT YOU REGARDING YOUR BID:						
304-366-4698						

CONTACT PERSON (PLEASE PRINT CLEARLY):				Phillip A. Cottrille		

SEE REVERSE SIDE FOR TERMS AND CONDITIONS

SIGNATURE	TELEPHONE	DATE
TITLE	FEIN	ADDRESS CHANGES TO BE NOTED ABOVE

WHEN RESPONDING TO RFQ, INSERT NAME AND ADDRESS IN SPACE ABOVE LABELED 'VENDOR'



State of West Virginia
 Department of Administration
 Purchasing Division
 2019 Washington Street East
 Post Office Box 50130
 Charleston, WV 25305-0130

Request for Quotation

RFQ NUMBER
7010EC01

PAGE
8

ADDRESS CORRESPONDENCE TO ATTENTION OF
**MICHAEL AUSTIN
 304-558-2402**

VENDOR

RFQ COPY
 TYPE NAME/ADDRESS HERE

SHIP TO

DIVISION OF HIGHWAYS
 EQUIPMENT DIVISION
 ROUTE 33
 BRUSHY FORK ROAD
 BUCKHANNON, WV
 26201 304-472-1750

DATE PRINTED	TERMS OF SALE	SHIP VIA	FOB	FREIGHT TERMS
09/02/2009				
BID OPENING DATE: 10/07/2009		BID OPENING TIME 01:30PM		

LINE	QUANTITY	UOP	CAT. NO.	ITEM NUMBER	UNIT PRICE	AMOUNT
***** THIS IS THE END OF RFQ 7010EC01 ***** TOTAL:						<u>6535.15</u>

SEE REVERSE SIDE FOR TERMS AND CONDITIONS

SIGNATURE	TELEPHONE	DATE
TITLE	FEIN	ADDRESS CHANGES TO BE NOTED ABOVE

WHEN RESPONDING TO RFQ, INSERT NAME AND ADDRESS IN SPACE ABOVE LABELED 'VENDOR'

WEST VIRGINIA DEPARTMENT OF TRANSPORTATION
DIVISION OF HIGHWAYS
EQUIPMENT DIVISION

PROCUREMENT SPECIFICATIONS
NO. 839-1-L

TRAILER MOUNTED SOLAR POWERED ELECTRIC ARROWBOARD

1.0 PURPOSE

It is the purpose of these specifications to describe a Trailer Mounted Solar Powered Electric Arrowboard (hereinafter referred to as an "arrowboard" or a "unit") to be purchased for use by the West Virginia Division of Highways (DOH) on an Open End Contract basis.

2.0 BIDDING PROCEDURES

The current purchasing procedures regarding bidding as established by the Department of Administration, Purchasing Division, shall apply. Failure to submit the "Request for Quotation" forms, complete in its entirety and according to directions indicated, may subject the bidder to disqualification. **Each bid submitted shall also be accompanied by a Bidder's Evaluation Report completed in detail.** Addendums in order, along with exception sheets, should be with Bidder's Evaluation Report. **FAILURE TO SUBMIT THE BIDDER'S EVALUATION REPORT, COMPLETE IN ITS ENTIRETY, MAY RESULT IN AUTOMATIC DISQUALIFICATION.**

3.0 SPECIFICATIONS

The specifications named herein, mandatory and non-mandatory, establish the acceptable level of quality only and are not intended to reflect a preference or favor any particular brand or vendor.

3.1 EXCEPTIONS TO NON-MANDATORY SPECIFICATIONS

Exception to a non-mandatory unit specification may be made by the bidder, providing the exception is not available from the manufacturer. **Any such exception must be noted on the bidder's evaluation report and should be accompanied by supporting documentation/literature from the manufacturer. Any exception must be indicated on a separate attachment to the bidder's evaluation report and labeled as "Exception to Specifications".** The state reserves the right to determine whether the stated exception does or does not reduce the quality and performance of the unit. Failure to provide information for any exceptions may be grounds for rejection of the bid. The state reserves the right to waive minor irregularities in bids or specifications in accordance with §148-1-4(f) of the WV Legislative Rules and Regulations.

3.2 MANDATORY SPECIFICATIONS

All specifications preceded by "shall, will, and/or must" or are stated as a "minimum and/or maximum" are mandatory as stated in Purchasing Divisions Policies and Procedures. Any bid failing to meet any mandatory item shall be immediately disqualified. Failure to respond in the appropriate evaluation section may also be grounds for immediate disqualification at the discretion of the State.

A mandatory pre-bid conference is scheduled for this equipment purchase as stated in the RFQ. Vendors having products with variations or exceptions in specified mandatory items are expected to address any such variations or exceptions during the pre-bid conference. **The State shall review and consider any such variation or exception, and may at its sole discretion, issue an addendum to change mandatory specifications deemed to be in the State's best interest. Bids from any vendor failing to attend the mandatory pre-bid shall be disqualified. Bids containing any variation or exception to a mandatory specification that was not addressed during the pre-bid conference and accepted by the issuance of an Addendum shall be disqualified.**

4.0 REPRESENTATIVE UNIT FOR TEST

The successful vendor must (if specified) provide DOH one (1) completed representative unit to be observed and evaluated on each order to insure compliance with specification. If requested, the time period for testing and evaluation shall be seven (7) working days following receipt of the unit. DOH will incur no obligation for deterioration of surfaces, finishes, seals, and mechanical or electrical parts on the unit resulting from operation and testing within the limits of these specifications; nor will DOH incur obligation for damage to the unit resulting from failure to meet specifications when due care and attention is given by DOH and testing is done within the limits of these specifications. Failure of the pilot unit to satisfactorily meet specifications as bid shall be cause for cancellation of the purchase order, and return of the delivered unit along with all associated equipment to the vendor at the vendor's expense.

4.1 CONDITION OF UNIT(S) UPON DELIVERY

All units must arrive at the prescribed delivery point having been completely preserviced with oil, lubricants, and coolant. All prescribed precautions pertaining to first operations and break-in of the unit are to be posted conspicuously on the unit for ready observance by the operator.

4.2 DELIVERY

Delivery point of the completely assembled representative unit will be the DOH, Equipment Division, Route 33 at Brushy Fork Road, Buckhannon, West Virginia (26201).

The vendor is responsible for guaranteeing delivery of the completed units within the time specified and agreed to by the State. Delivery is preferred within 35 days after receipt of purchase agreement. The vendor is responsible for establishing and coordinating delivery terms with allied manufacturers or suppliers. **Delivery terms shall**

be stated in the bid and the State reserves the right to accept or negotiate such terms. Failure to reach an agreement may result in rejection of the bid. **The successful**

bidder shall provide their manufacturer's confirmation of the order to the WVDOH contact person within seven (7) working days after receiving the approved purchase order.

A completed pilot model for inspection must be provided within 20 calendar days after receipt of the purchase agreement by the successful vendor.

Delivery is an integral part of this specification and failure to comply will be cause to initiate a D.O.T. Administrative Form WV-82, Vendor Performance Form. The WV-82 Form will provide a means of officially notifying the Purchasing Division and the vendor of unsatisfactory performance; such as late deliveries, poor service, inadequate parts supplies, etc.

The decision to initiate subject Form will be at the sole discretion of the D.O.H. Commissioner's established Equipment Review Board.

Issuance of the WV-82 Vendor Complaint Form on unsatisfactory delivery against any vendor will be cause to refuse to consider similar items from those vendors on future Request For Quotations.

(NOTE: Delivery time could be altered due to labor strikes, severe inclement weather conditions, etc.)

5.0 AWARD CRITERIA

- 5.1 DOH will recommend the award in accordance with the RFQ evaluation criteria described in the requisition. **The award shall be made to the lowest unit cost vendor that meets or exceeds the specifications.** DOH reserves the right to place multiple orders in any quantity.

6.0 SPECIFICATIONS AND GUIDELINES - GENERAL

6.1 IDENTIFICATION OF THE UNIT BEING PROPOSED

The bidder must identify the unit by manufacturer, model, series, and year of manufacture, in the bid to enable identification by DOH in the manufacturer's specifications of the proposed unit. The bidder will submit complete descriptive literature of the proposed unit, to establish that the bid is the manufacturer's most current model, including latest engineering improvements, which have been, or will imminently be, regularly advertised and sold on the open market. The unit specified herein and offered to be manufactured after January 1, 2009 and be clearly identified and marked with date of manufacture.

6.2 OPERATING AND SERVICE MANUALS AND PARTS LISTS

An operator's manual must be included with each unit upon delivery. A "line sheet" (if applicable) and Equipment Preventative Maintenance Questionnaire (as shown in X6.2 of the Bidder's Evaluation Report) must be with pilot unit upon delivery. In addition, there must be 12 service, shop, or maintenance manuals; ten

(10) to be distributed to the Districts and two (2) for the Equipment Division. Also, there must be 14 parts manuals; ten (10) to be distributed to the Districts and four (4) for Equipment Division use. CD ROM is preferred in lieu of parts or service manuals.

* **NOTE: MANUALS SHALL BE DELIVERED UPON COMPLETION OF DELIVERY OF TOTAL UNITS. FAILURE TO DO SO WILL DELAY PAYMENT.**

6.3 TRAINING:

Manufacturers and/or dealers will be required to stage a thorough seminar on the subjects of Preventative Maintenance, Operator and Mechanic Training. **In order to keep the operators and mechanics updated, the successful vendor shall conduct training with each purchase order against this open end contract.** Training is preferred within 2 working days after delivery of the pilot unit on the individual purchase order.

Manufacturers and/or dealers shall be required to furnish the Training Academy with one (1) Operator's Manual to be shipped direct to WVDOH Training Academy, Post Office Box 610, Buckhannon, West Virginia 26201 prior to delivery of the pilot.

The seminar to be held at the W. Va. Division of Highways, Equipment Division, Buckhannon, West Virginia.

6.4 PREVENTIVE MAINTENANCE AND OPERATOR PROCEDURES:

Manufacturers and/or dealers will be required to submit to the Equipment Division, in addition to the operating and service manuals, booklets and pamphlets explaining the Preventive Maintenance and Operator Procedures to be used by the operators of this equipment, and must include such things as daily prestart inspection procedure, service schedule, and routine maintenance required, safety precautions, etc.

The successful vendor shall furnish all training aids; i.e., videos, projectors, etc. required in conducting the training.

6.5 WARRANTY AND SERVICE POLICY

The Manufacturers warranty or service policy is to apply to the unit. Such warranty or service policy is to be recognized at any authorized unit dealer, representing manufacturer of proposed unit throughout the State of West Virginia. The applicable warranty or service policy will not be contingent upon obtaining routine service, lubrication, and servicing of the unit from factory authorized agencies. It will be the responsibility of the bidder to have available labor to repair or replace any defective replacement parts, components and materials, and to have available those replacement parts, components, and/or materials found to be defective during the terms of the warranty period. The bidder should state the labor rates, locations where parts will be stocked, availability of parts, and discounts offered for parts, when terms of the warranty offer a pro-rated cost for parts and labor. In addition, the successful bidder should offer field work to repair or replace defective parts, components, and materials found to be defective during the terms of the warranty and should provide mechanic's travel rates,

mileage charges, field mechanic rates, and any surcharge for miscellaneous items, if applicable, for field work during the warranty period. Submit to Division of Highways any technical or engineering improvements during the term of the warranty. **The unit must be accompanied upon delivery by the unit's manufacturer's executed warranty or service policy.**

A mandatory minimum two (2) year bumper to bumper basic parts and labor warranty excluding abuse and normal wear items is required for this unit.

THE "WARRANTY AND SERVICE POLICY QUESTIONNAIRE" ATTACHED IN THE BIDDER'S EVALUATION REPORT MUST BE COMPLETED IN ITS ENTIRETY BY THE SUCCESSFUL BIDDER OR MANUFACTURER PRIOR TO DELIVERY OF THE PILOT MODEL. (SEE SECTION X6.5 OF BIDDER'S EVALUATION REPORT).

6.6 EVALUATION COMMITTEE REQUIREMENTS

Detailed component specifications, product literature, component models, required for specification compliance determination by the Evaluation Committee should be provided with each bid. Any information supplied that is contrary to/or conflicting with the specifications and/or attached Bidders Evaluation Report may be sufficient cause for rejection of bid.

6.7 UNSPECIFIED ACCESSORIES & FEATURES

All parts, equipment, accessories, material, design and performance characteristics not specified herein, but which are necessary to provide a complete unit, must be furnished with each unit and required to conform to strength, quality of material, and quality of workmanship to those which are advertised and provided to the market in general by the unit industry.

All parts and accessories advertised and regularly supplied as standard shall be included, except those which would represent duplication of these specified, and except those which, by specification, are not to be furnished. All standard safety features, required by Federal and State Law, shall be included.

7.0 SPECIFICATIONS OF THE QUOTED UNIT ARE AS FOLLOWS:

Unit shall have built in auxiliary battery charger which would enable the batteries to be hooked up to an AC power source at the storage yard or off of a generator in the field so that the batteries could be fully charged. Charge time and charger version shall be based on the manufacturers battery configuration.

- 7.1 Arrowboard:
 - 7.1.1 The arrowboard to be a weather-tight panel approximately 48 inches high by 96 inches wide.
 - 7.1.2 The height from the bottom of the panel to the roadway should be seven (7) feet above the roadway.
 - 7.1.3 The face of the panel should be flat back with 15 hooded lamps.
 - 7.1.3.1 **Lamp shall be five (5) inch amber LED with minimum angularity of 33 degrees.**
 - 7.1.4 The unit to have the capability of the following modes of operations:
 - 7.1.4.1 Right Arrow - ten (10) lamps flashing in unison.
 - 7.1.4.2 Left Arrow - ten (10) lamps flashing in unison.
 - 7.1.4.3 Double Arrow - five (5) lamps in each arrowhead and three (3) lamps in shaft, all flashing in unison.
 - 7.1.4.4 Warning Bar - seven (7) horizontal lamps flashing in unison.
 - 7.1.4.5 Four Point Caution - four (4) outermost corner lamps flashing in unison.
 - 7.1.4.6 Indicator Lights on back of panel.
 - 7.1.5 The flash rate should be 30 fpm and the flash cycle time to be two (2) seconds with 50 percent on time.
 - 7.1.6 The unit should reduce lamp brightness when the ambient light level drops below five (5) foot candles, plus or minus one (1) foot candle, **and shall increase lamp brightness when the ambient light level increases to five (5) foot candles, plus or minus one (1) foot candle.**
 - 7.1.7 **Unit should have minimum legibility distance of one (1) mile.**
- 7.2 Electrical System:
 - 7.2.1 **The solar generator shall incorporate a 12 Volt DC Photovoltaic Solar Panel mounted on a self-erecting, automatic positioning device located above the unit.**
 - 7.2.2 **The battery bank shall be of sufficient size and capacity to power the unit for 30 days with no solar assist.**
 - 7.2.3 The batteries to be protected to prevent damaged due to overcharging or discharging too deeply at any temperature.

- 7.2.4 The unit to have an external warning light, or other device to indicate when the unit is in need of auxiliary charging prior to arrow shutoff.
- 7.2.5 The battery compartment should be vented, protected by a special acid-resistant finish, and lockable.
- 7.2.6 **The arrowboard controller shall be housed in a weatherproof, lockable enclosure.**
- 7.2.7 **Unit shall be safe guarded from any unwanted outside RF interference which would include but not be limited to VHF/FM receiver, 2-way radio receiver, cell phones, etc.**
- 7.2.8 The unit to be equipped with an hour meter.
- 7.3 Trailer:
 - 7.3.1 The trailer to be equipped with the following:
 - 7.3.1.1 2,000 lb. axle with leaf springs.
 - 7.3.1.2 Tubeless, standard tread tires and wheels.
 - 7.3.1.3 Heavy duty pintle eye hitch
 - 7.3.1.4 Adjustable jack stand on trailer tongue.
 - 7.3.1.5 Adjustable jack stands to stabilize unit while in operation.
 - 7.3.1.6 Approved lighting and safety chains for highway use.
 - 7.3.1.7 Heavy duty light wiring for towing of unit with quick disconnect plug Cole Hersee Part Number 12081 male or equal.
 - 7.3.1.8 License plate brackets.
 - 7.3.1.9 Wheel fenders.
 - 7.3.1.10 The arrowboard to be raised and lowered using a hand operating winch (or hydraulic pump and ram) and locked into place using latches of steel pins with keeper chains permanently attached to the unit.
- 7.4 Paint:
 - 7.4.1 The unit to be painted the manufacturers standard color except that the arrowboard will be painted flat black.
- 7.5 **Vendor must certify that the arrowboard offered will meet or exceed the "Occupational Safety and Health Act of 1970" or subsequent changes that are in effect at time of manufacture of the unit.**

- 7.6 Advertising: No visible decals or nameplates or painted on names representing the manufacturer or model number or trademark should appear on the exterior surfaces of the unit. Such logos created through the stamping or casting process of manufacture are accepted.
- 7.7 All other features considered as standard equipment but not specifically addressed above.
- 7.8 Preventive Maintenance & Operator's Training School:

Manufacturers and/or dealers will be required to stage a thorough seminar on each order on the subjects Preventive Maintenance and Operator Training. The seminar should be held at the Equipment Division.

In addition to the operating and service manuals, booklets and pamphlets explaining the Preventive Maintenance and Operator Training procedures to be used by the operators of this equipment are also required. Must include such things as daily prestart inspection procedure, service schedule and routing maintenance required, safety precautions, etc.

Bidder to attach a copy of the proposed program with his bid, state the time required to perform the program, and briefly describe his program.

The successful vendor to furnish all training aids; i.e. videos, projectors, etc., required in conducting the training.

WEST VIRGINIA DEPARTMENT OF TRANSPORTATION
DIVISION OF HIGHWAYS
EQUIPMENT DIVISION

BIDDER'S EVALUATION REPORT

PROCUREMENT SPECIFICATIONS FOR OPEN END CONTRACT
NO. 839-1-L

TRAILER MOUNTED SOLAR POWERED ELECTRIC ARROWBOARD

NOTE TO BIDDER: Procurement Specification No. 839-1-L, Paragraph 2.0 recommends the completion and submittal of this Report with your bid. Purpose of this Report is to enable the West Virginia Division of Highways Evaluation Committee to make full and fair evaluation of the bid. Addendums in order, along with a summary of exception as a separate attachment, should be with Bidder's Evaluation Report. FAILURE TO SUBMIT THIS REPORT, COMPLETE IN ITS ENTIRETY, MAY SUBJECT THE BIDDER TO DISQUALIFICATION.

Reference Requisition No.: 7010EC01

Bidder's Name: Middletown Tractor Sales

Address: 2345 Whitehall Boulevard Fairmont, WV 26554

Telephone Number: 304-366-4690

Years Bidder has been registered to do business with the State of West Virginia: 36 YRS.

Years Company has been an authorized dealer for proposed unit: < 1 YRS.

X3.2 Have you complied with all mandatory specifications? YES NO

X4.2 DELIVERY:

X4.2.1 Delivery date of completed representative unit: 30 Calendar Days After Receipt of Purchase Agreement

X4.2.2 Delivery date of balance of completed units: 5 Calendar Days After Receipt of Purchase Agreement

The Bidder's Evaluation Reports are ready for download on Purchasing's Web site at www.state.wv.us/admin/purchase

X5.0 AWARD CRITERIA;

X5.1 Price per unit:

\$ 6,525.15 per unit

X6.0 SPECIFICATIONS - GENERAL

X6.1 Manufacturer, model, series, and date of manufacture of proposed unit:

TEAM FENEX MODEL TMABVA15 2009
Is descriptive literature, fully describing proposed unit attached to your bid? YES NO

If not, why? _____

X6.2 Will the required number of service manuals, and complete parts list be delivered to the Equipment Division at Buckhannon upon completion of delivery of total units?

YES NO

Will the required Equipment Preventive Maintenance Form (Section X6.2 of Bidders Evaluation Report) be provided upon inspection of the pilot unit?

YES NO

EQUIPMENT PREVENTATIVE MAINTENANCE QUESTIONNAIRE

THIS FORM MUST BE COMPLETED IN ITS ENTIRETY BY SUCCESSFUL BIDDER OR MANUFACTURER'S TECHNICAL REPRESENTATIVE PRIOR TO DELIVERY OF PILOT MODEL TO THE WVDOT.

DESCRIPTION: _____ MAKE: _____

MODEL: _____ YEAR: _____ PURCHASE AMOUNT: _____

ENGINE: MAKE: _____ MODEL: _____ FUEL TYPE: _____

HORSEPOWER: _____ CYLINDER: _____ ENGINE SERIAL: _____

COOLING SYSTEM CAPACITY: _____

BELTS: DESCRIPTION: _____ PART NUMBERS: _____

GVW: _____ AXLE CAPACITY:FRONT: _____ REAR: _____

TIRES: FRONT MAKE & SIZE: _____

REAR MAKE & SIZE: _____

DIMENSIONS OF UNIT: LENGTH: _____ WIDTH: _____ LENGTH: _____

VENDOR CONTACT PERSON: _____ PHONE: _____

PARTS:

BATTERY MAKE: _____ MODEL: _____ CCA: _____

TOP OR SIDE POST: _____ DIMENSIONS: LENGTH _____ WIDTH _____ HEIGHT _____

SPARK PLUGS OR FUEL INJECTORS MAKE: _____ PART # _____

FUEL PUMP OR INJECTION PUMP MAKE: _____ MODEL: _____

ALTERNATOR MAKE: _____ PART #: _____

STARTER MAKE: _____ PART #: _____

TURBO CHARGER MAKE: _____ PART #: _____

TRANS. MAKE: _____ MODEL: _____ AUTO/MANUAL: _____

HYDRAULIC PUMP MAKE: _____ MODEL: _____

FILTERS MAKE PART NO. LUBRICANT MANUFACTURER TYPE

OIL _____ ENGINE _____

AIR INNER _____ TRANSMISSION _____

AIR OUTER _____ POWER STEERING _____

FUEL PRIMARY _____ HYDRAULIC _____

FUEL SECONDARY _____ DIFFERENTIALS _____

COOLANT _____ BRAKE FLUID _____

HYDRAULIC _____ COOLANT _____

OTHER _____ OTHER _____

X6.3 TRAINING:

Will training seminar be conducted on Preventive Maintenance, Operator and Mechanic Training YES NO

Will you conduct training with each purchase order against this open end contract? YES NO

Will training be conducted within 2 working days from the delivery of the pilot unit on the individual purchase order? YES NO

If NO, explain time frame _____

Will an Operator's Manual be furnished directly to Training Academy prior to the delivery of the pilot? YES NO

X6.4 If you are the successful vendor, will you furnish all training aids, i.e., videos, projectors, required in conducting the training? YES NO

X6.4.1 Will all manuals, booklets, etc. explaining preventive maintenance, operator procedures, and service schedule be delivered with each unit? YES NO

If NO, explain _____

X6.5 WARRANTY AND SERVICE POLICY

Will the warranty and service you provide comply with all areas as stated in Section 6.5 of specifications YES NO

Is warranty literature attached? YES NO

Is a minimum two (2) year bumper to bumper basic parts and labor warranty excluding abuse and normal wear items included? YES NO

Describe: SEE warranty attachment.

THIS FORM MUST BE COMPLETED IN ITS ENTIRETY AND SUBMITTED WITH YOUR BID.

(If additional lines are needed, make copies of form.)

1. Define the terms of the standard warranty. If not offered, so state. (Attach copy)

1-year, bumper to bumper, defect in materials and/or workmanship

2. Define warranty service to be performed at DOH facilities and warranty service to be performed at manufacturer's representative facility. List name and location of manufacturer's representative.

Any and all warranty issues can be addressed at any of the DOH facilities, travel and/or transportation charges excluded.

3. List locations for parts inventories that are within the State of West Virginia. Also, list availability levels, if known.

Middletown Tractor Sales, Fairmont, wV 26554

4. During the term of warranty, list the guarantee discount to manufacturer's published list price for parts that bidder will sell the parts to owner.

- A. Terms: Net 30 Manufacturer's published list price less: 5 % discount
- B. Terms: Net 60 Manufacturer's published list price less: 2 % discount
- C. Terms: Net 90 Manufacturer's published list price less: 0 % discount

5. During the term of warranty, will all manufacturers or engineering improvements be submitted to Division of Highways? x YES NO

6. During the term of warranty, list the guaranteed rates charged for repair to the unit.

- A. Shop Rate \$ 55.00 per mechanic hour
- B. Travel Time Charge \$ 60.00 per mechanic hour
(Specify if one-way) _____; port to port _____
- C. Mileage Charge \$ NA per vehicle mile
(Specify if one-way) _____; port to port _____
- D. Field Mechanic Rate \$ 60.00 per mechanic hour
- E. Specify period of time that prices are in effect: 1-Year
- F. Surcharge for miscellaneous items: 15 %

X6.6 EVALUATION COMMITTEE REQUIREMENTS

Is all component specifications, product literature, component models provided for Evaluation Committee bid determination? YES NO

X6.7 Will all parts, equipment, accessories, material, design and performance characteristics not specified herein, but which are necessary to provide a complete unit, be furnished with the unit and conform in strength, quality of material, and quality of workmanship to those which are advertised and provided to the market in general by the unit industry? YES NO

X6.7.1 Are all parts and accessories adequate and regularly supplied as standard to be included except those which may be duplications of specifications herein, and except these by specification are not to be furnished? YES NO

X6.7.2 Are all standard safety features that are required by Federal and State statutes of law included? YES NO

X7.0 SPECIFICATIONS OF THE QUOTED UNIT

The bidder should complete the following schedule in order for the Division to compare the actual bid unit to the specifications. Should the bidder except a requirement, then such exception may be only on the basis that such feature is not offered by the manufacturer. The Division will have the sole discretion as to whether the bidder's substitution meets the requirements of the specifications.

Does unit have built in auxiliary battery charger which would enable batteries to be hooked up to an AC power source at the storage yard or off of a generator in the field YES NO

Is charge time and charger version based on manufacturer's battery configuration YES NO

Describe: 10 Amp @ 3-5 hrs. or 2 Amp @ 2 to 12 hrs

Manufacturer: Satumaker Model: SE-520 MA

X7.1 Arrowboard:

X7.1.1 Is the arrowboard panel weather-tight: YES NO

Describe weather-tight design and materials used:

INDIVIDUAL bulbs circuits SEALED

Arrow Board panel dimensions: 48 inches high x 96 inches wide

- X7.1.2 Height from bottom of panel to roadway 6.29 feet above roadway
- X7.1.3 Is the face of the panel flat black, with fifteen (15) hooded lamps?
 YES NO
- X7.1.3.1 Does lamp have five (5) inch amber LED with minimum angularity of 33 degrees
 YES NO
- X7.1.4 Modes of operation capability:
- X7.1.4.1 Right arrow – 10 lamps flashing in unison YES NO
- X7.1.4.2 Left arrow – 10 lamps flashing in unison YES NO
- X7.1.4.3 Double arrow – 5 lamps in each arrowhead and 3 lamps in shaft, all flashing in unison
 YES NO
- X7.1.4.4 Warning bar – 7 horizontal lamps flashing in unison YES NO
- X7.1.4.5 Four Point Caution – 4 outermost corner lamps flashing in unison
 YES NO
- X7.1.4.6 Indicator lights on back of panel YES NO
- X7.1.5 Is the unit flash rate 30 flashes per minute with a flash cycle time of two (2) seconds with 50 percent on time?
 YES NO
- X7.1.6 Will the unit reduce lamp brightness when the ambient light level drops below five (5) foot candles, plus or minus one (1) foot candle, and increase lamp brightness when the ambient light level increases to five (5) foot candles, plus or minus one (1) foot candle?
 YES NO
- X7.1.7 Unit's minimum distance of legibility: 1 mile(s)
- X7.2 Electrical System:
- X7.2.1 Does the solar generator incorporate a 12 Volt DC photovoltaic solar panel mounted on a self-erecting automatic positioning device located above the unit?
 YES NO
- X7.2.2 Is the battery bank of sufficient size and capacity to power the unit for 30 days without solar assist?
 YES NO
- X7.2.3 Are the batteries protected in a manner that will prevent damage due to overcharging or discharging to deeply at any temperature?
 YES NO

- X7.2.4 Does the unit have an external warning light, or other warning signal device, to indicate when the unit is in need of auxiliary charging prior to arrow shutoff?
 YES NO
- X7.2.5 Is the battery compartment vented, protected by an acid-resistant finish, and lockable?
 YES NO
- X7.2.6 Is the arrowboard controller housed in a lockable weatherproof enclosure?
 YES NO
- X7.2.7 Is unit safe guarded from any unwanted outside RF interference which would include but not be limited to VHF/FM receiver, 2-way radio receiver, cell phones, etc.
 YES NO
- X7.2.8 Is the unit equipped with an operational hour meter? YES NO
- X7.3 Trailer:
- X7.3.1 Is the trailer equipped with the following:
- X7.3.1.1 2,000 lb. axle with leaf springs YES NO
- X7.3.1.2 Tubeless standard tread tires and wheels YES NO
- X7.3.1.3 Heavy duty pintle eye hitch YES NO
- X7.3.1.4 Adjustable jack stand on trailer tongue YES NO
- X7.3.1.5 Adjustable jack stands to stabilize unit while in operation
 YES NO
- X7.3.1.6 Approved lighting and safety chains for highway use YES NO
- X7.3.1.7 Heavy duty light wiring for towing of unit with quick disconnect plug Cole Hersee Part Number 12081 male or equal YES NO
- X7.3.1.8 License plate brackets YES NO
- X7.3.1.9 Wheel fenders YES NO
- X7.3.1.10 Arrowboard raised and lowered using a hand operating winch (or hydraulic pump/ram) locked into place using latches of steel pins with keeper chains permanently attached to the unit YES NO

X7.4 Paint:

X7.4.1 Describe proposed method of painting the unit: _____

NET paint, AMERON, AMERSHIELD, Highway
Orange RESIN 2 part epoxy

X7.5 Does the proposed unit meet or exceed the "Occupational Safety and Health Act of 1970" requirements and/or any subsequent changes at the time manufactured?

YES NO

X7.6 Does the unit conform to advertising guidelines?

YES NO

X7.7 List all other standard features considered as standard equipment but not specifically addressed in the specifications: _____

HD Trailer Frame - SEE SPEC

X7.8 Preventive Maintenance and Operator's Training School:

Will a preventative maintenance and operator's training seminar be provided with each order?

YES NO

If you are the successful vendor, will you furnish all training aids, i.e., videos, projectors, required in conducting the training?

YES NO

Will all manuals, booklets, etc. preventive maintenance, operator procedures, and service schedule be delivered with each unit?

YES NO

If NO, explain _____

Have you attached a copy of the proposed program with your bid, stating the time required to perform the program and brief description of program YES NO

VENDOR PREFERENCE CERTIFICATE

Certification and application* is hereby made for Preference in accordance with West Virginia Code, §5A-3-37. (Does not apply to construction contracts). West Virginia Code, §5A-3-37, provides an opportunity for qualifying vendors to request (at the time of bid) preference for their residency status. Such preference is an evaluation method only and will be applied only to the cost bid in accordance with the West Virginia Code. This certificate for application is to be used to request such preference. The Purchasing Division will make the determination of the Resident Vendor Preference, if applicable.

- 1. Application is made for 2.5% resident vendor preference for the reason checked: Bidder is an individual resident vendor and has resided continuously in West Virginia for four (4) years immediately preceding the date of this certification; or, X Bidder is a partnership, association or corporation resident vendor and has maintained its headquarters or principal place of business continuously in West Virginia for four (4) years immediately preceding the date of this certification; or 80% of the ownership interest of Bidder is held by another individual, partnership, association or corporation resident vendor who has maintained its headquarters or principal place of business continuously in West Virginia for four (4) years immediately preceding the date of this certification; or, Bidder is a nonresident vendor which has an affiliate or subsidiary which employs a minimum of one hundred state residents and which has maintained its headquarters or principal place of business within West Virginia continuously for the four (4) years immediately preceding the date of this certification; or,
2. Application is made for 2.5% resident vendor preference for the reason checked: Bidder is a resident vendor who certifies that, during the life of the contract, on average at least 75% of the employees working on the project being bid are residents of West Virginia who have resided in the state continuously for the two years immediately preceding submission of this bid; or,
3. Application is made for 2.5% resident vendor preference for the reason checked: Bidder is a nonresident vendor employing a minimum of one hundred state residents or is a nonresident vendor with an affiliate or subsidiary which maintains its headquarters or principal place of business within West Virginia employing a minimum of one hundred state residents who certifies that, during the life of the contract, on average at least 75% of the employees or Bidder's affiliate's or subsidiary's employees are residents of West Virginia who have resided in the state continuously for the two years immediately preceding submission of this bid; or,
4. Application is made for 5% resident vendor preference for the reason checked: Bidder meets either the requirement of both subdivisions (1) and (2) or subdivision (1) and (3) as stated above; or,
5. Application is made for 3.5% resident vendor preference who is a veteran for the reason checked: Bidder is an individual resident vendor who is a veteran of the United States armed forces, the reserves or the National Guard and has resided in West Virginia continuously for the four years immediately preceding the date on which the bid is submitted; or,
6. Application is made for 3.5% resident vendor preference who is a veteran for the reason checked: Bidder is a resident vendor who is a veteran of the United States armed forces, the reserves or the National Guard, if, for purposes of producing or distributing the commodities or completing the project which is the subject of the vendor's bid and continuously over the entire term of the project, on average at least seventy-five percent of the vendor's employees are residents of West Virginia who have resided in the state continuously for the two immediately preceding years.

Bidder understands if the Secretary of Revenue determines that a Bidder receiving preference has failed to continue to meet the requirements for such preference, the Secretary may order the Director of Purchasing to: (a) reject the bid; or (b) assess a penalty against such Bidder in an amount not to exceed 5% of the bid amount and that such penalty will be paid to the contracting agency or deducted from any unpaid balance on the contract or purchase order.

By submission of this certificate, Bidder agrees to disclose any reasonably requested information to the Purchasing Division and authorizes the Department of Revenue to disclose to the Director of Purchasing appropriate information verifying that Bidder has paid the required business taxes, provided that such information does not contain the amounts of taxes paid nor any other information deemed by the Tax Commissioner to be confidential.

Under penalty of law for false swearing (West Virginia Code, §61-5-3), Bidder hereby certifies that this certificate is true and accurate in all respects; and that if a contract is issued to Bidder and if anything contained within this certificate changes during the term of the contract, Bidder will notify the Purchasing Division in writing immediately.

Bidder: Middletown Tractor Sales Signed: _____

Date: 03 October 2009 Title: Sales Consultant _____

*Check any combination of preference consideration(s) indicated above, which you are entitled to receive.

STATE OF WEST VIRGINIA
Purchasing Division

PURCHASING AFFIDAVIT

VENDOR OWING A DEBT TO THE STATE:

West Virginia Code §5A-3-10a provides that: No contract or renewal of any contract may be awarded by the state or any of its political subdivisions to any vendor or prospective vendor when the vendor or prospective vendor or a related party to the vendor or prospective vendor is a debtor and the debt owed is an amount greater than one thousand dollars in the aggregate.

PUBLIC IMPROVEMENT CONTRACTS & DRUG-FREE WORKPLACE ACT:

If this is a solicitation for a public improvement construction contract, the vendor, by its signature below, affirms that it has a written plan for a drug-free workplace policy in compliance with Article 1D, Chapter 21 of the *West Virginia Code*. The vendor **must** make said affirmation with its bid submission. Further, public improvement construction contract may not be awarded to a vendor who does not have a written plan for a drug-free workplace policy in compliance with Article 1D, Chapter 21 of the *West Virginia Code* and who has not submitted that plan to the appropriate contracting authority in timely fashion. For a vendor who is a subcontractor, compliance with Section 5, Article 1D, Chapter 21 of the *West Virginia Code* may take place before their work on the public improvement is begun.

ANTITRUST:

In submitting a bid to any agency for the state of West Virginia, the bidder offers and agrees that if the bid is accepted the bidder will convey, sell, assign or transfer to the state of West Virginia all rights, title and interest in and to all causes of action it may now or hereafter acquire under the antitrust laws of the United States and the state of West Virginia for price fixing and/or unreasonable restraints of trade relating to the particular commodities or services purchased or acquired by the state of West Virginia. Such assignment shall be made and become effective at the time the purchasing agency tenders the initial payment to the bidder.

I certify that this bid is made without prior understanding, agreement, or connection with any corporation, firm, limited liability company, partnership or person or entity submitting a bid for the same materials, supplies, equipment or services and is in all respects fair and without collusion or fraud. I further certify that I am authorized to sign the certification on behalf of the bidder or this bid.

LICENSING:

Vendors must be licensed and in good standing in accordance with any and all state and local laws and requirements by any state or local agency of West Virginia, including, but not limited to, the West Virginia Secretary of State's Office, the West Virginia Tax Department, West Virginia Insurance Commission, or any other state agencies or political subdivision. Furthermore, the vendor must provide all necessary releases to obtain information to enable the Director or spending unit to verify that the vendor is licensed and in good standing with the above entities.

CONFIDENTIALITY:

The vendor agrees that he or she will not disclose to anyone, directly or indirectly, any such personally identifiable information or other confidential information gained from the agency, unless the individual who is the subject of the information consents to the disclosure in writing or the disclosure is made pursuant to the agency's policies, procedures and rules. Vendor further agrees to comply with the Confidentiality Policies and Information Security Accountability Requirements, set forth in <http://www.state.wv.us/admin/purchase/privacy/noticeConfidentiality.pdf>.

Under penalty of law for false swearing (*West Virginia Code* §61-5-3), it is hereby certified that the vendor affirms and acknowledges the information in this affidavit and is in compliance with the requirements as stated.

Vendor's Name: Middletown Tractor Sales

Authorized Signature: _____ Date: 03 October 2009

TEAM FENEX , A Division of Leggett & Platt

610 ILLINOIS AVE . SANDOVAL, IL 62882 . PHONE: 618/247-3200 FAX: 618/247-9055

CHECK LIST FOR TRAILER MOUNTED ARROW BOARD

BASE UNIT INCLUDES THE FOLLOWING:

15" WHEELS, 5 LUGS ON 4 1/2" CENTERS

4 FT. X 8 FT. ARROW BOARD WITH CONTROLLER

STANDARD COLOR: HIGHWAY SAFETY ORANGE

STANDARD BASE UNIT

<u>FENEX #</u>	<u>QTY.</u>	<u>DESCRIPTION</u>
TMABVA-15	(X)	TRAILER MOUNTED ARROW BOARD 15 LIGHT

RUNNING GEAR

07-5016	(X)	HEAVY DUTY 3500 LB E-Z LUBE IDLER AXLE
---------	-------	--

TAIL LIGHT OPTIONS

07-5122	(X)	TAIL LIGHT CONN. 6 CONDUCTOR COLE HERSEE WITH JUNCTION BOX
07-5126	(X)	STANDARD TAIL LIGHT OPTION

TOWING OPTIONS

07-5101	(X)	LUNETTE EYE 2 1/2"
10-0227	(2)	SAFETY CHAIN 5/16 X 36" WITH HOOKS

SOLAR PANELS

07-5125A	(X)	SINGLE SOLAR PANEL
----------	-------	--------------------

ACCESSORY OPTIONS

07-5102	(X)	BATTERY CHARGER WITH CORD REEL
07-5110	(X)	BATTERY CONDITION INDICATOR-VISIBLE TO OUTSIDE



SOLAR POWERED ARROWBOARD TRAILERS

FIFTEEN AND TWENTY FIVE LIGHT MODELS

The Arrowboard Trailer designed specifically for the utility industry. Includes a speedy rig up and rig down design that handles the punishment of repeated daily use for traffic control at multiple locations.



SOLAR POWERED ARROWBOARD TRAILERS

- 3500 LB AXLE
- E Z – Lube Axle
- ST 205 - 75 D 15 Tires
- Lunette Eye or Ball Hitch Available
- Cole Hersee Four Prong Truck Hook-Up.
- Four Stabilizers / Outriggers
- Dolly Landing Jack

1-800-88FENEX



www.teamfenex.com



SOLAR POWERED ARROWBOARD TRAILERS

STANDARD FEATURES: QUALITY CONSTRUCTION

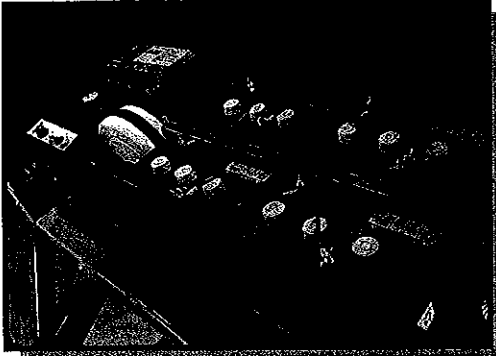

View of four, six volt deep cycle batteries

Standard Features:

- Virtually Maintenance Free Design.
- Quiet Operation - No Generator.
- Heavy-Duty Frame Construction.
- Trailer Balanced Weight Distribution for Towing and Unhitched Positioning.
- Integrated Solar Regulator.
- Low Battery Warning Alarm.
- Battery Saver Shut-Down.
- Automatic Day / Night Mode.
- Flashing Arrow Modes: Left, Right, Double, Bar and Four Corner Caution.
- 60 Watt Solar Panels.
- Four, 6-volt Deep Cycle Batteries.

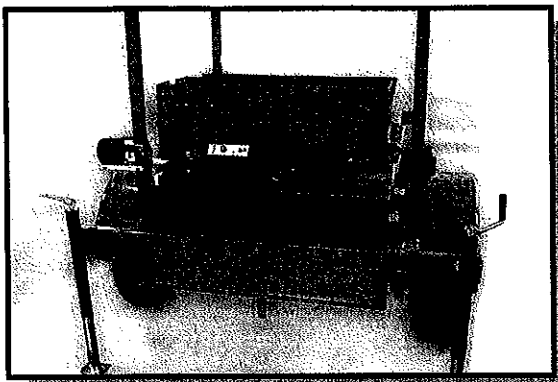

View of optional in frame sign storage

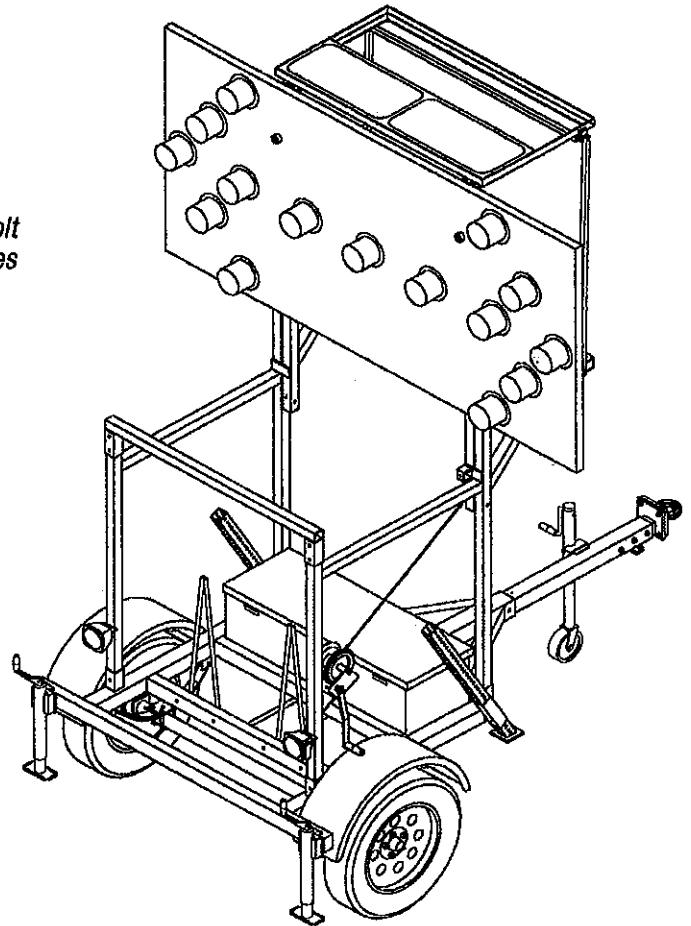

Selected Options:

- Battery Charger with Cord Reel.
- Remote Battery Condition Indicator.
- Cone Holders (Up to 40 Cones Capacity).
- Reflective Rear Panel.
- Brakes.
- Wheel Chocks.
- Sign Storage for Hard and Roll-up Displays.
- Removable Tow Bar.
- Utility "Spec" Tow Vehicle Connections.
- 25-light Sequential Display.



TEAM FENEX 15 LIGHT ARROWBOARD TRAILER

I. TRAILER SPECIFICATIONS

- a. **GENERAL** The trailer shall be suitable for its intended use as a carrier and base for the arrowboard, controller, solar panel and battery pack. It shall be towable at all highway speeds up to 60 M.P.H. on paved road surfaces. The manufacturer shall warrant it for a period of 1 year against manufacturing defects when serviced to manufacturer's specifications. The trailer is designed to be set up and down multiple times per day.
- b. **TRAILER FRAME** The frame shall be constructed so as to provide a stable platform for the cautionary lighting equipment. It shall be the "A" frame type tongue, equipped with a lunette eye and safety chains (no welds on chains) that are a removable attachment. The tongue tube shall contain a retractable screw-type landing jack. The whole assembly, frame and board supports shall be painted highway safety orange. The "H" frame is constructed of 2" X 3" 1/8" wall tubing, uprights for arrow 2" X 2" 1/8" wall tubing, and the tongue 3" X 3" 3/16" wall tubing.

The running gear shall consist of, as a minimum, a 3500# rated axle with ez-lube inner and outer bearings, spring assemblies sized to carry the load both on and off road. The tire / rim assembly shall be 15" tires, specifically to be ST205 / 75D15, to be compatible with other equipment.

The frame shall have 4 each out-rigger stabilizers to level the entire unit on uneven terrain and positioned so as to stabilize the unit during high wind conditions, or drafts created by passing traffic.

The trailer shall have high visibility locating stanchions on the rear corners of the frame. The stanchions are angled away from the trailer to provide a means of making the rear of the trailer visible from the tow vehicle.

Lights, running / stop / brake shall meet all federal D.O.T. regulations. The trailer wiring shall be protected from weather hazards and wiring designed so as to be concealed and protected from physical damage. Wiring for lighting shall terminate in a junction box located inside the channel on the "A" frame. The connection to the prime mover shall be a

4' cable, hard-wired to the junction box and terminating in a connector, meeting customer specifications.

Units shall be delivered in a "ready – for – service" condition.

- c. **BATTERY ENCLOSURE** The enclosure for battery storage shall be sized for the batteries required, lockable, and ventilated. It shall allow for easy removal of the batteries for servicing. It shall be treated to prevent corrosion from an acid environment.
- e. **BATTERY PACK** Contains 4 each, 6 volt deep cycle batteries, batteries shall be sized at 225 amp hour
 - 1) Battery charger is hard-wired to a retractable power cord reel with 30' of power cord. Enclosure shall be lockable while power cord is extended and plugged into an A.C. outlet.
 - 2) **ARROW / SOLAR PANEL SUPPORT PLATFORM** The platform shall be constructed and sized to provide proper height for the arrow display and strong enough to provide proper support, both in display and transport mode. The platform shall contain a winch and cable assembly for raising and lowering the arrow and a locking device for transport. The winch shall be located so an operator of average size can raise the display comfortably and without undue stress.

II. LIGHT BOARD SPECIFICATIONS

- a. **ARROWBOARD PANEL** Shall be a 4' x 8' galvanized steel panel finished in matte black. It shall contain 15 L.E.D. prism cut lamps; high output, low power consumption, sealed beam, long-life.
- b. **CONTROLLER** The controller shall contain an integrated solar regulator, warning alarm for low battery, an automatic day / night mode sensor and shall provide the following flashing modes:
 - 1.Right Arrow
 - 2.Left Arrow
 - 3.Double Arrow

- 4.Bar Caution
- 5.Four corner Caution

c. **SINGLE SOLAR PANEL** (65 Watt) Designed and mounted on a pivotal frame so as to always face the sun, in the display mode or transport mode. (Note: Controller has battery-saver shut-down)

The trailer – mounted arrowboard will carry the following warranties:

- | | |
|-----------------------------|--------|
| a. Trailer and running gear | 1 year |
| b. Electrical controller | 2 year |
| c. L.E.D. lamps | 2 year |
| d. Solar Panel | 5 year |



State of West Virginia
 Department of Administration
 Purchasing Division
 2019 Washington Street East
 Post Office Box 50130
 Charleston, WV 25305-0130

Request for Quotation

RFQ NUMBER
7010EC01

PAGE
1

ADDRESS CORRESPONDENCE TO ATTENTION OF
MICHAEL AUSTIN 304-558-2402

*709043751 304-366-4690
 MIDDLETOWN TRACTOR SALES
 2345 WHITEHALL BLVD
 FAIRMONT WV 26554

DIVISION OF HIGHWAYS
 EQUIPMENT DIVISION
 ROUTE 33
 BRUSHY FORK ROAD
 BUCKHANNON, WV
 26201 304-472-1750

DATE PRINTED	TERMS OF SALE	SHIP VIA	F.O.B.	FREIGHT TERMS
09/16/2009				

BID OPENING DATE: 10/07/2009 BID OPENING TIME 01:30PM

LINE	QUANTITY	UOP	CAT NO.	ITEM NUMBER	UNIT PRICE	AMOUNT
ADDENDUM NO. 1						
DELETE "PURCHASING CARD ACCEPTANCE" IN ITS ENTIRETY.						
BID OPENING DATE AND TIME REMAINS 10/07/09 @ 1:30 P.M.						
NO OTHER CHANGES.						
0001	1	EA		550-96		
TO PROVIDE TRAILER MOUNTED SOLAR POWERED AAROWBOARD						
***** THIS IS THE END OF RFQ 7010EC01 ***** TOTAL:						

SEE REVERSE SIDE FOR TERMS AND CONDITIONS

SIGNATURE <i>Phillip A. Stovall</i>	TELEPHONE 304-366-4690	DATE 06 Oct. 2009
TITLE Sales Consultant	FERN 55-054-7175	ADDRESS CHANGES TO BE NOTED ABOVE

WHEN RESPONDING TO RFQ, INSERT NAME AND ADDRESS IN SPACE ABOVE LABELED 'VENDOR'



MIDDLETOWN TRACTOR SALES

2345 WHITEHALL BLVD.
FAIRMONT, WV 26554

304-366-4690 (EXT 42)
304-366-4698 (FAX)

www.middletowntractor.com

03 October 2009

**State of West Virginia
Department of Administration
Purchasing Division
2019 Washington Street, East
Post Office Box 50130
Charleston, WV 25305-0130
REF: RFQ# 7010EC01 Exceptions**

Please review this memo for an explanation of the exceptions we have taken.

X6.5 (Warranty) Refer to attached letter of explanation

Manufacture does not offer a 2-year warranty on this unit except as stated.

**X7.14.1 (10 Lamps Flashing) Bid unit has 9 lamps flashing. Distortion occurs if last bulb inline
Flashes.**

X7.14.2 (10 Lamps Flashing) Refer above.

X7.2.8 (Hour meter) N/A

Respectfully yours;

Phillip A. Cottrille
PHIL@MIDDLETOWNTRACTOR.COM
304-483-6770 (CELL)

SOLAR POWERED ARROWBOARD TRAILERS

FIFTEEN AND TWENTY FIVE LIGHT MODELS

The Arrowboard Trailer designed specifically for the utility industry. Includes a speedy rig up and rig down design that handles the punishment of repeated daily use for traffic control at multiple locations.

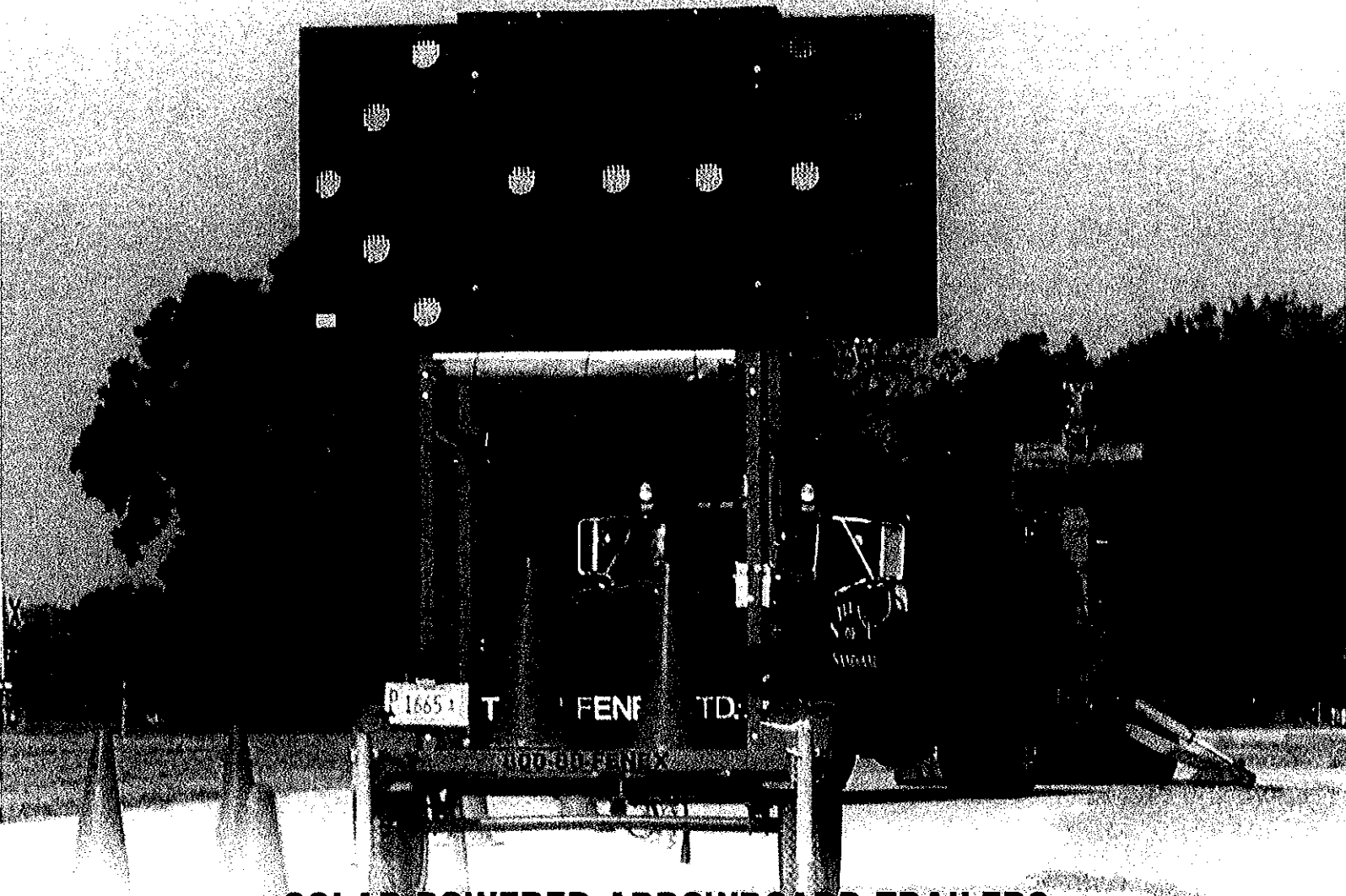

SOLAR POWERED ARROWBOARD TRAILERS

- 3500 LB AXLE
- E Z – Lube Axle
- ST 205 - 75 D 15 Tires
- Lunette Eye or Ball Hitch Available
- Cole Hersee Four Prong Truck Hook-Up.
- Four Stabilizers / Outriggers
- Dolly Landing Jack

SOLAR POWERED ARROWBOARD TRAILERS

STANDARD FEATURES: QUALITY CONSTRUCTION

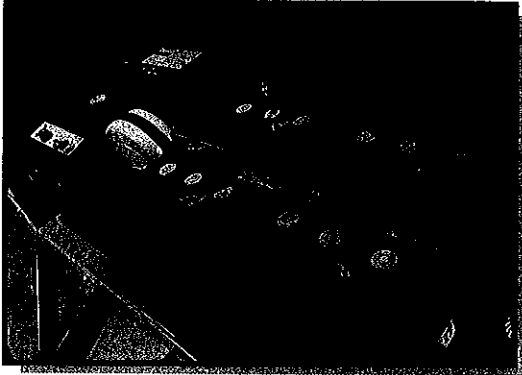

View of four, six volt deep cycle batteries

Standard Features:

- Virtually Maintenance Free Design.
- Quiet Operation - No Generator.
- Heavy-Duty Frame Construction.
- Trailer Balanced Weight Distribution for Towing and Unhitched Positioning.
- Integrated Solar Regulator.
- Low Battery Warning Alarm.
- Battery Saver Shut-Down.
- Automatic Day / Night Mode.
- Flashing Arrow Modes: Left, Right, Double, Bar and Four Corner Caution.
- 60 Watt Solar Panels.
- Four, 6-volt Deep Cycle Batteries.

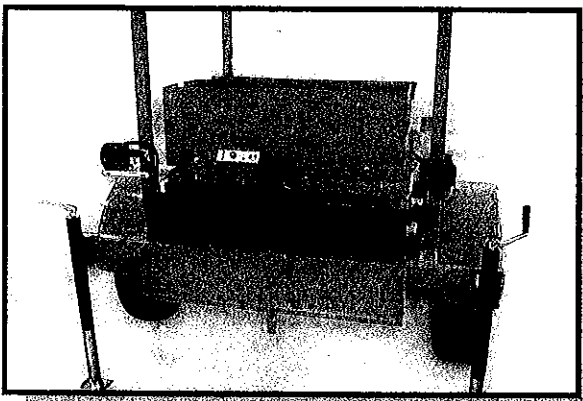

View of optional in frame sign storage

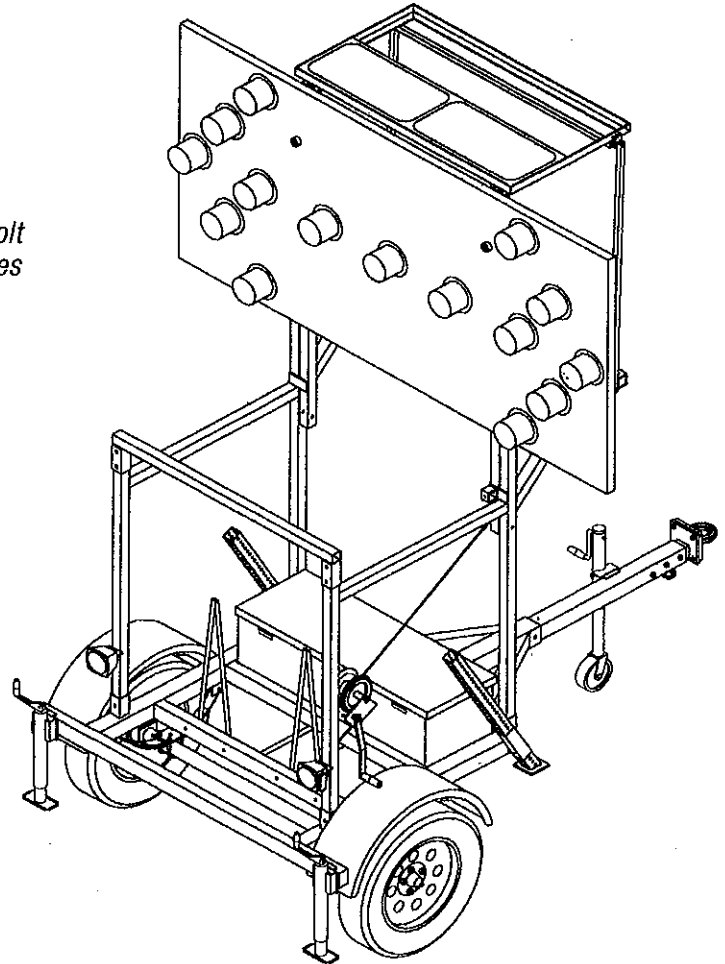

Selected Options:

- Battery Charger with Cord Reel.
- Remote Battery Condition Indicator.
- Cone Holders (Up to 40 Cones Capacity).
- Reflective Rear Panel.
- Brakes.
- Wheel Chocks.
- Sign Storage for Hard and Roll-up Displays.
- Removable Tow Bar.
- Utility "Spec" Tow Vehicle Connections.
- 25-light Sequential Display.