



State of West Virginia
 Department of Administration
 Purchasing Division
 2019 Washington Street East
 Post Office Box 50130
 Charleston, WV 25305-0130

**Request for
 Quotation**

RFQ NUMBER
7010EC01

PAGE
1

ADDRESS CORRESPONDENCE TO ATTENTION OF
**MICHAEL AUSTIN
 304-558-2402**

RFQ COPY
 TYPE NAME/ADDRESS HERE

VENDOR

**LOGAN CORPORATION
 RT. 2, BOX 924
 CLARKSBURG, WV 26301**

SHIP TO

**DIVISION OF HIGHWAYS
 EQUIPMENT DIVISION
 ROUTE 33
 BRUSHY FORK ROAD
 BUCKHANNON, WV
 26201 304-472-1750**

DATE PRINTED 09/02/2009	TERMS OF SALE Net 30	SHIP VIA Motor freight	FOB Delivered	FREIGHT TERMS Pre Paid
BID OPENING DATE: 10/07/2009		BID OPENING TIME 01:30PM		

LINE	QUANTITY	UOP	CAT NO	ITEM NUMBER	UNIT PRICE	AMOUNT
0001	1	EA		550-96	\$ 3955. ⁰⁰ each	\$ 3955. ⁰⁰ each
<p>TO PROVIDE TRAILER MOUNTED SOLAR POWERED AAROWBOARD</p> <p>OPEN END CONTRACT</p> <p>TO PROVIDE TRAILER MOUNTED SOLAR POWERED ELECTRIC ARROWBOARDS FOR THE WEST VIRGINIA DIVISION OF HIGHWAYS PER THE ATTACHED SPECIFICATIONS.</p> <p>MANDATORY PRE-BID</p> <p>A MANDATORY PRE-BID WILL BE HELD ON 09/15/2009 AT 10:00 AM AT THE EQUIPMENT DIVISION BUCKHANNON, WV. ALL INTERESTED PARTIES ARE REQUIRED TO ATTEND THIS MEETING FAILURE TO ATTEND THE MANDATORY PRE-BID SHALL RESULT IN DISQUALIFICATION OF THE BID. NO ONE PERSON MAY REPRESENT MORE THAN ONE BIDDER.</p> <p>AN ATTENDANCE SHEET WILL BE MADE AVAILABLE FOR ALL POTENTIAL BIDDERS TO COMPLETE. THIS WILL SERVE AS THE OFFICIAL DOCUMENT VERIFYING ATTENDANCE AT THE MANDATORY PRE-BID. FAILURE TO PROVIDE YOUR COMPANY AND REPRESENTATIVE NAME ON THE ATTENDANCE SHEET WILL RESULT IN DISQUALIFICATION OF THE BID. THE STATE WILL NOT ACCEPT ANY OTHER DOCUMENTATION TO VERIFY ATTENDANCE. THE BIDDER IS RESPONSIBLE FOR ENSURING THEY HAVE COMPLETED THE INFORMATION REQUIRED ON THE ATTENDANCE SHEET. THE PURCHASING DIVISION AND THE STATE AGENCY WILL NOT ASSUME ANY RESPONSIBILITY FOR A BIDDER-S FAILURE TO COMPLETE THE PRE-BID ATTENDANCE SHEET. IN ADDITION, WE REQUEST THAT ALL POTENTIAL BIDDERS INCLUDE THEIR E-MAIL ADDRESS AND FAX NUMBER.</p>						

RECEIVED

2009 OCT -6 A 10:17

PURCHASING DIVISION
 STATE OF WV

SEE REVERSE SIDE FOR TERMS AND CONDITIONS			
SIGNATURE <i>Joseph M. Dicks</i>	TELEPHONE 304-641-2011	DATE 10/5/09	
TITLE Territory Mgr.	FEIN 55-0219530	ADDRESS CHANGES TO BE NOTED ABOVE	

WHEN RESPONDING TO RFQ, INSERT NAME AND ADDRESS IN SPACE ABOVE LABELED 'VENDOR'

**GENERAL TERMS & CONDITIONS
REQUEST FOR QUOTATION (RFQ) AND REQUEST FOR PROPOSAL (RFP)**

1. Awards will be made in the best interest of the State of West Virginia.
2. The State may accept or reject in part, or in whole, any bid.
3. All quotations are governed by the *West Virginia Code* and the *Legislative Rules* of the Purchasing Division.
4. Prior to any award, the apparent successful vendor must be properly registered with the Purchasing Division and have paid the required \$125 fee.
5. All services performed or goods delivered under State Purchase Order/Contracts are to be continued for the term of the Purchase Order/Contracts, contingent upon funds being appropriated by the Legislature or otherwise being made available. In the event funds are not appropriated or otherwise available for these services or goods, this Purchase Order/Contract becomes void and of no effect after June 30.
6. Payment may only be made after the delivery and acceptance of goods or services.
7. Interest may be paid for late payment in accordance with the *West Virginia Code*.
8. Vendor preference will be granted upon written request in accordance with the *West Virginia Code*.
9. The State of West Virginia is exempt from federal and state taxes and will not pay or reimburse such taxes.
10. The Director of Purchasing may cancel any Purchase Order/Contract upon 30 days written notice to the seller.
11. The laws of the State of West Virginia and the *Legislative Rules* of the Purchasing Division shall govern all rights and duties under the Contract, including without limitation the validity of this Purchase Order/Contract.
12. Any reference to automatic renewal is hereby deleted. The Contract may be renewed only upon mutual written agreement of the parties.
13. **BANKRUPTCY:** In the event the vendor/contractor files for bankruptcy protection, the State may deem this contract null and void, and terminate such contract without further order.
14. **HIPAA BUSINESS ASSOCIATE ADDENDUM:** The West Virginia State Government HIPAA Business Associate Addendum (BAA), approved by the Attorney General, and available online at the Purchasing Division's web site (<http://www.state.wv.us/admin/purchase/vro/hipaa.htm>) is hereby made part of the agreement. Provided that, the Agency meets the definition of a Cover Entity (45 CFR §160.103) and will be disclosing Protected Health Information (45 CFR §160.103) to the vendor.
15. **WEST VIRGINIA ALCOHOL & DRUG-FREE WORKPLACE ACT:** If this Contract constitutes a public improvement construction contract as set forth in Article 1D, Chapter 21 of the West Virginia Code ("The West Virginia Alcohol and Drug-Free Workplace Act"), then the following language shall hereby become part of this Contract: "The contractor and its subcontractors shall implement and maintain a written drug-free workplace policy in compliance with the West Virginia Alcohol and Drug-Free Workplace Act, as set forth in Article 1D, Chapter 21 of the West Virginia Code. The contractor and its subcontractors shall provide a sworn statement in writing, under the penalties of perjury, that they maintain a valid drug-free work place policy in compliance with the West Virginia and Drug-Free Workplace Act. It is understood and agreed that this Contract shall be cancelled by the awarding authority if the Contractor: 1) Fails to implement its drug-free workplace policy; 2) Fails to provide information regarding implementation of the contractor's drug-free workplace policy at the request of the public authority; or 3) Provides to the public authority false information regarding the contractor's drug-free workplace policy."

INSTRUCTIONS TO BIDDERS

1. Use the quotation forms provided by the Purchasing Division.
2. **SPECIFICATIONS:** Items offered must be in compliance with the specifications. Any deviation from the specifications must be clearly indicated by the bidder. Alternates offered by the bidder as **EQUAL** to the specifications must be clearly defined. A bidder offering an alternate should attach complete specifications and literature to the bid. The Purchasing Division may waive minor deviations to specifications.
3. Complete all sections of the quotation form.
4. Unit prices shall prevail in case of discrepancy.
5. All quotations are considered F.O.B. destination unless alternate shipping terms are clearly identified in the quotation.
6. **BID SUBMISSION:** All quotations must be delivered by the bidder to the office listed below prior to the date and time of the bid opening. Failure of the bidder to deliver the quotations on time will result in bid disqualifications: Department of Administration, Purchasing Division, 2019 Washington Street East, P.O. Box 50130, Charleston, WV 25305-0130



State of West Virginia
 Department of Administration
 Purchasing Division
 2019 Washington Street East
 Post Office Box 50130
 Charleston, WV 25305-0130

**Request for
 Quotation**

BFO NUMBER
 7010EC01

PAGE
 2

ADDRESS CORRESPONDENCE TO ATTENTION OF
 MICHAEL AUSTIN
 304-558-2402

RFQ COPY
 TYPE NAME/ADDRESS HERE

LOGAN CORPORATION
 RT. 2, BOX 924
 CLARKSBURG, WV 26301

DIVISION OF HIGHWAYS
 EQUIPMENT DIVISION
 ROUTE 33
 BRUSHY FORK ROAD
 BUCKHANNON, WV
 26201 304-472-1750

DATE PRINTED	TERMS OF SALE	SHIP VIA	FOB	FREIGHT TERMS
09/02/2009				

BID OPENING DATE: 10/07/2009 BID OPENING TIME 01:30PM

LINE	QUANTITY	UOP	GAT NO	ITEM NUMBER	UNIT PRICE	AMOUNT
<p>ALL POTENTIAL BIDDERS ARE REQUESTED TO ARRIVE PRIOR TO THE STARTING TIME FOR THE PRE-BID. BIDDERS WHO ARRIVE LATE, BUT PRIOR TO THE DISMISSAL OF THE TECHNICAL PORTION OF THE PRE-BID WILL BE PERMITTED TO SIGN IN. BIDDERS WHO ARRIVE AFTER CONCLUSION OF THE TECHNICAL PORTION OF THE PRE-BID, BUT DURING ANY SUBSEQUENT PART OF THE PRE-BID WILL NOT BE PERMITTED TO SIGN THE ATTENDANCE SHEET.</p> <p>EXHIBIT 2</p> <p>LIFE OF CONTRACT: THIS CONTRACT BECOMES EFFECTIVE ON AND EXTENDS FOR A PERIOD OF ONE (1) YEAR OR UNTIL SUCH "REASONABLE TIME" THEREAFTER AS IS NECESSARY TO OBTAIN A NEW CONTRACT OR RENEW THE ORIGINAL CONTRACT. THE "REASONABLE TIME" PERIOD SHALL NOT EXCEED TWELVE (12) MONTHS. DURING THIS "REASONABLE TIME" THE VENDOR MAY TERMINATE THIS CONTRACT FOR ANY REASON UPON GIVING THE DIRECTOR OF PURCHASING THIRTY (30) DAYS WRITTEN NOTICE.</p> <p>UNLESS SPECIFIC PROVISIONS ARE STIPULATED IN THIS CONTRACT DOCUMENT, THE TERMS, CONDITIONS, AND PRICING SET HEREIN ARE FIRM FOR THE LIFE OF THE CONTRACT.</p> <p>RENEWAL: THIS CONTRACT MAY BE RENEWED UPON THE MUTUAL WRITTEN CONSENT OF THE SPENDING UNIT AND VENDOR, SUBMITTED TO THE DIRECTOR OF PURCHASING THIRTY (30) DAYS PRIOR TO THE EXPIRATION DATE. SUCH RENEWAL SHALL BE IN ACCORDANCE WITH THE TERMS AND CONDITIONS OF THE ORIGINAL CONTRACT AND SHALL BE LIMITED TO TWO (2) ONE (1) YEAR PERIODS.</p> <p>CANCELLATION: THE DIRECTOR OF PURCHASING RESERVES THE</p>						

SEE REVERSE SIDE FOR TERMS AND CONDITIONS

SIGNATURE	TELEPHONE	DATE
TITLE	FEIN	ADDRESS CHANGES TO BE NOTED ABOVE

WHEN RESPONDING TO RFQ, INSERT NAME AND ADDRESS IN SPACE ABOVE LABELED 'VENDOR'



State of West Virginia
 Department of Administration
 Purchasing Division
 2019 Washington Street East
 Post Office Box 50130
 Charleston, WV 25305-0130

Request for Quotation

RFQ NUMBER:
7010EC01

PAGE:
3

ADDRESS CORRESPONDENCE TO ATTENTION OF:
**MICHAEL AUSTIN
 304-558-2402**

VENDOR

RFQ COPY
 TYPE NAME/ADDRESS HERE

**LOGAN CORPORATION
 RT. 2, BOX 924
 CLARKSBURG, WV 26301**

SHIP TO

**DIVISION OF HIGHWAYS
 EQUIPMENT DIVISION
 ROUTE 33
 BRUSHY FORK ROAD
 BUCKHANNON, WV
 26201 304-472-1750**

DATE PRINTED 09/02/2009	TERMS OF SALE	SHIP VIA	FOB	FREIGHT TERMS
-----------------------------------	---------------	----------	-----	---------------

BID OPENING DATE: **10/07/2009** BID OPENING TIME **01:30PM**

LINE	QUANTITY	UOP	CAT NO	ITEM NUMBER	UNIT PRICE	AMOUNT
<p>RIGHT TO CANCEL THIS CONTRACT IMMEDIATELY UPON WRITTEN NOTICE TO THE VENDOR IF THE COMMODITIES AND/OR SERVICES SUPPLIED ARE OF AN INFERIOR QUALITY OR DO NOT CONFORM WITH THE SPECIFICATIONS OF THE BID AND CONTRACT HEREIN.</p> <p>OPEN MARKET CLAUSE: THE DIRECTOR OF PURCHASING MAY AUTHORIZE A SPENDING UNIT TO PURCHASE ON THE OPEN MARKET, WITHOUT THE FILING OF A REQUISITION OR COST ESTIMATE, ITEMS SPECIFIED ON THIS CONTRACT FOR IMMEDIATE DELIVERY IN EMERGENCIES DUE TO UNFORESEEN CAUSES (INCLUDING BUT NOT LIMITED TO DELAYS IN TRANSPORTATION OR AN UNANTICIPATED INCREASE IN THE VOLUME OF WORK).</p> <p>QUANTITIES: QUANTITIES LISTED IN THE REQUISITION ARE APPROXIMATIONS ONLY, BASED ON ESTIMATES SUPPLIES BY THE STATE SPENDING UNIT. IT IS UNDERSTOOD AND AGREED THAT THE CONTRACT SHALL COVER THE QUANTITIES ACTUALLY ORDERED FOR DELIVERY DURING THE TERM OF CONTRACT, WHETHER MORE OR LESS THAN THE QUANTITIES SHOWN.</p> <p>ORDERING PROCEDURE: SPENDING UNIT(S) SHALL ISSUE A WRITTEN EQUIPMENT CONTRACT ORDER (FORM NUMBER WV-35) FOR COMMODITIES COVERED BY THIS CONTRACT. THE ORIGINAL WV-35 MUST BE SENT TO THE PURCHASING DIVISION OF THE DEPARTMENT OF ADMINISTRATION. AFTER APPROVAL AND ENCUMBRANCE, ONE COPY OF THE PURCHASE ORDER WILL BE RETURNED TO THE SPENDING UNIT AND ONE COPY FORWARDED TO THE VENDOR AS AUTHORIZATION FOR SHIPMENT. NO ORDER IS VALID UNLESS APPROVED AND ENCUMBERED BY THE PURCHASING DIVISION.</p> <p>BANKRUPTCY: IN THE EVENT THE VENDOR/CONTRACTOR FILES FOR BANKRUPTCY PROTECTION, THE STATE MAY DEEM THE CONTRACT NULL AND VOID, AND TERMINATE SUCH CONTRACT WITHOUT FUTHER ORDER.</p>						

SEE REVERSE SIDE FOR TERMS AND CONDITIONS

SIGNATURE	TELEPHONE	DATE
TITLE	FEIN	ADDRESS CHANGES TO BE NOTED ABOVE

WHEN RESPONDING TO RFQ, INSERT NAME AND ADDRESS IN SPACE ABOVE LABELED 'VENDOR'



State of West Virginia
 Department of Administration
 Purchasing Division
 2019 Washington Street East
 Post Office Box 50130
 Charleston, WV 25305-0130

Request for Quotation

RFQ NUMBER
7010EC01

PAGE
4

ADDRESS CORRESPONDENCE TO ATTENTION OF
MICHAEL AUSTIN 304-558-2402

RFQ COPY

TYPE NAME/ADDRESS HERE

VENDOR

LOGAN CORPORATION
 RT. 2, BOX 924
 CLARKSBURG, WV 26301

SHIP TO

DIVISION OF HIGHWAYS
 EQUIPMENT DIVISION
 ROUTE 33
 BRUSHY FORK ROAD
 BUCKHANNON, WV
 26201 304-472-1750

DATE PRINTED	TERMS OF SALE	SHIP VIA	F.O.B.	FREIGHT TERMS
09/02/2009				

BID OPENING DATE: 10/07/2009 BID OPENING TIME 01:30PM

LINE	QUANTITY	UOP	CAT NO	ITEM NUMBER	UNIT PRICE	AMOUNT
	REV. 5/2009					
<p>PURCHASING CARD ACCEPTANCE: THE STATE OF WEST VIRGINIA CURRENTLY UTILIZES A VISA PURCHASING CARD PROGRAM WHICH IS ISSUED THROUGH A BANK. THE SUCCESSFUL VENDOR MUST ACCEPT THE STATE OF WEST VIRGINIA VISA PURCHASING CARD FOR PAYMENT OF ALL ORDERS PLACED BY ANY STATE AGENCY AS A CONDITION OF AWARD.</p>						
EXHIBIT 4						
<p>LOCAL GOVERNMENT BODIES: UNLESS THE VENDOR INDICATES IN THE BID HIS REFUSAL TO EXTEND THE PRICES, TERMS, AND CONDITIONS OF THE BID TO COUNTY, SCHOOL, MUNICIPAL AND OTHER LOCAL GOVERNMENT BODIES, THE BID SHALL EXTEND TO POLITICAL SUBDIVISIONS OF THE STATE OF WEST VIRGINIA. IF THE VENDOR DOES NOT WISH TO EXTEND THE PRICES, TERMS, AND CONDITIONS OF THE BID TO ALL POLITICAL SUBDIVISIONS OF THE STATE, THE VENDOR MUST CLEARLY INDICATE SUCH REFUSAL IN HIS BID. SUCH REFUSAL SHALL NOT PREJUDICE THE AWARD OF THIS CONTRACT IN ANY MANNER.</p>						
REV. 3/88						
EXHIBIT 6						
<p>PRICE ADJUSTMENT PROVISION: THE STATE OF WEST VIRGINIA WILL CONSIDER BIDS THAT CONTAIN PROVISIONS FOR PRICE ADJUSTMENTS PRIOR TO THE ORIGINAL EXPIRATION OF THE CONTRACT, PROVIDED THAT</p>						

SEE REVERSE SIDE FOR TERMS AND CONDITIONS

SIGNATURE	TELEPHONE	DATE
TITLE	FEIN	ADDRESS CHANGES TO BE NOTED ABOVE

WHEN RESPONDING TO RFQ, INSERT NAME AND ADDRESS IN SPACE ABOVE LABELED 'VENDOR'



State of West Virginia
 Department of Administration
 Purchasing Division
 2019 Washington Street East
 Post Office Box 50130
 Charleston, WV 25305-0130

Request for Quotation

RFP NUMBER
7010EC01

PAGE
5

ADDRESS CORRESPONDENCE TO ATTENTION OF
MICHAEL AUSTIN
304-558-2402

PROPERTY

RFQ COPY
 TYPE NAME/ADDRESS HERE

LOGAN CORPORATION
RT. 2, BOX 924
CLARKSBURG, WV 26301

SHIP TO

DIVISION OF HIGHWAYS
EQUIPMENT DIVISION
ROUTE 33
BRUSHY FORK ROAD
BUCKHANNON, WV
26201 **304-472-1750**

DATE PRINTED 09/02/2009	TERMS OF SALE	SHIP VIA	FOB	FREIGHT TERMS
-----------------------------------	---------------	----------	-----	---------------

BID OPENING DATE: **10/07/2009** BID OPENING TIME **01:30PM**

LINE	QUANTITY	UOP	CAT NO	ITEM NUMBER	UNIT PRICE	AMOUNT
<p>SUCH PRICE ADJUSTMENT COVERS BOTH UPWARD AND DOWNWARD MOVEMENT OF THE COMMODITY PRICE, AND THAT ADJUSTMENT IS BASED ON THE "PASS THROUGH" INCREASE OR DECREASE OF RAW MATERIALS AND/OR LABOR, WHICH MAKE UP ALL OR A SUBSTANTIAL PART OF A PRODUCT. ADJUSTMENTS ARE TO BE BASED UPON AN ACTUAL DOLLAR FIGURE, NOT A PERCENTAGE. ALL PRICE ADJUSTMENT REQUESTS MUST BE SUBSTANTIATED IN A MANNER ACCEPTABLE TO THE DIRECTOR PURCHASING, E.G. GOVERNMENTAL BENCH MARKS, GENERAL MARKET INCREASE, PUBLISHED PRICE LISTS. SUCH REQUESTS FOR AND INCREASE SHOULD BE RECEIVED IN WRITING BY THE DIRECTOR OF PURCHASING AT LEAST 30 DAYS IN ADVANCE OF THE EFFECTIV DATE OF THE INCREASE. ANY TIME THE VENDOR REQUESTS A PRICE ADJUSTMENT, THE PURCHASING DIVISION MAY EITHER ACCEPT THE PRICE ADJUSTMENT AND AMEND THE CONTRACT ACCORDINGLY OR REJECT THE ADJUSTMENT IN ITS ENTIRETY AND CANCEL THE CONTRACT.</p> <p>EXHIBIT 10</p> <p>REQUISITION NO.:</p> <p>ADDENDUM ACKNOWLEDGEMENT</p> <p>I HEREBY ACKNOWLEDGE RECEIPT OF THE FOLLOWING CHECKED ADDENDUM(S) AND HAVE MADE THE NECESSARY REVISIONS TO MY PROPOSAL, PLANS AND/OR SPECIFICATION, ETC.</p> <p>ADDENDUM NO.'S:</p> <p>NO. 1 <i>J.A.</i>.....</p> <p>NO. 2</p> <p>NO. 3</p>						

SEE REVERSE SIDE FOR TERMS AND CONDITIONS

SIGNATURE	TELEPHONE	DATE
TITLE	FEIN	ADDRESS CHANGES TO BE NOTED ABOVE

WHEN RESPONDING TO RFQ, INSERT NAME AND ADDRESS IN SPACE ABOVE LABELED 'VENDOR'



State of West Virginia
 Department of Administration
 Purchasing Division
 2019 Washington Street East
 Post Office Box 50130
 Charleston, WV 25305-0130

Request for Quotation

RFQ NUMBER
7010EC01

PAGE
6

ADDRESS CORRESPONDENCE TO ATTENTION OF
**MICHAEL AUSTIN
 304-558-2402**

VENDOR

RFQ COPY
 TYPE NAME/ADDRESS HERE

**LOGAN CORPORATION
 RT. 2, BOX 924
 CLARKSBURG, WV 26301**

SHIP TO

**DIVISION OF HIGHWAYS
 EQUIPMENT DIVISION
 ROUTE 33
 BRUSHY FORK ROAD
 BUCKHANNON, WV
 26201 304-472-1750**

DATE PRINTED	TERMS OF SALE	SHIP VIA	FOB	FREIGHT TERMS
09/02/2009				

BID OPENING DATE: **10/07/2009** BID OPENING TIME **01:30PM**

LINE	QUANTITY	UOP	CAT NO	ITEM NUMBER	UNIT PRICE	AMOUNT
	NO. 4					
	NO. 5					
<p>I UNDERSTAND THAT FAILURE TO CONFIRM THE RECEIPT OF TH ADDENDUM(S) MAY BE CAUSE FOR REJECTION OF BIDS.</p> <p>VENDOR MUST CLEARLY UNDERSTAND THAT ANY VERBAL REPRESENTATION MADE OR ASSUMED TO BE MADE DURING ANY ORAL DISCUSSION HELD BETWEEN VENDOR'S REPRESENTATIVES AND ANY STATE PERSONNEL IS NOT BINDING. ONLY THE INFORMATION ISSUED IN WRITING AND ADDED TO THE SPECIFICATIONS BY AN OFFICIAL ADDENDUM IS BINDING.</p> <p style="text-align: right;"> <i>Joseph M. Dield</i> SIGNATURE <i>Logan Corporation</i> COMPANY <i>10/5/09</i> DATE </p> <p>REV. 11/96</p> <p style="text-align: center;">NOTICE</p> <p>A SIGNED BID MUST BE SUBMITTED TO:</p> <p style="text-align: center;">DEPARTMENT OF ADMINISTRATION PURCHASING DIVISION BUILDING 15</p>						

SEE REVERSE SIDE FOR TERMS AND CONDITIONS

SIGNATURE	TELEPHONE	DATE
TITLE	FEIN	ADDRESS CHANGES TO BE NOTED ABOVE

WHEN RESPONDING TO RFQ, INSERT NAME AND ADDRESS IN SPACE ABOVE LABELED 'VENDOR'



State of West Virginia
 Department of Administration
 Purchasing Division
 2019 Washington Street East
 Post Office Box 50130
 Charleston, WV 25305-0130

Request for Quotation

RFQ NUMBER
7010EC01

PAGE
8

ADDRESS CORRESPONDENCE TO ATTENTION OF
MICHAEL AUSTIN 304-558-2402

RFQ COPY
 TYPE NAME/ADDRESS HERE

LOGAN CORPORATION
 RT. 2, BOX 924
 CLARKSBURG, WV 26301

DIVISION OF HIGHWAYS
 EQUIPMENT DIVISION
 ROUTE 33
 BRUSHY FORK ROAD
 BUCKHANNON, WV
 26201 304-472-1750

DATE PRINTED	TERMS OF SALE	SHIP VIA	FOB	FREIGHT TERMS
09/02/2009				

BID OPENING DATE: 10/07/2009 BID OPENING TIME 01:30PM

LINE	QUANTITY	UOP	QTY NO.	ITEM NUMBER	UNIT PRICE	AMOUNT
***** THIS IS THE END OF RFQ 7010EC01 ***** TOTAL:						

SEE REVERSE SIDE FOR TERMS AND CONDITIONS

SIGNATURE	TELEPHONE	DATE
TITLE	FEIN	ADDRESS CHANGES TO BE NOTED ABOVE

WHEN RESPONDING TO RFQ, INSERT NAME AND ADDRESS IN SPACE ABOVE LABELED 'VENDOR'

WEST VIRGINIA DEPARTMENT OF TRANSPORTATION
DIVISION OF HIGHWAYS
EQUIPMENT DIVISION

BIDDER'S EVALUATION REPORT

PROCUREMENT SPECIFICATIONS FOR OPEN END CONTRACT
NO. 839-1-L

TRAILER MOUNTED SOLAR POWERED ELECTRIC ARROWBOARD

NOTE TO BIDDER: Procurement Specification No. 839-1-L, Paragraph 2.0 recommends the completion and submittal of this Report with your bid. Purpose of this Report is to enable the West Virginia Division of Highways Evaluation Committee to make full and fair evaluation of the bid. Addendums in order, along with a summary of exception as a separate attachment, should be with Bidder's Evaluation Report. FAILURE TO SUBMIT THIS REPORT, COMPLETE IN ITS ENTIRETY, MAY SUBJECT THE BIDDER TO DISQUALIFICATION.

Reference Requisition No.: 7010EC01

Bidder's Name: Logan Corporation

Address: Rt 2 Box 924 Clarksburg, WV 26301

Telephone Number: 304-623-5670

Years Bidder has been registered to do business with the State of West Virginia: 37 YRS.

Years Company has been an authorized dealer for proposed unit: 1 YRS.

X3.2 Have you complied with all mandatory specifications? YES NO

X4.2 DELIVERY:

X4.2.1 Delivery date of completed representative unit: 20 Calendar Days After
Receipt of Purchase Agreement

X4.2.2 Delivery date of balance of completed units: 35 Calendar Days After Receipt of
Purchase Agreement

The *Bidder's Evaluation Reports* are ready for download on Purchasing's Web site at
www.state.wv.us/admin/purchase

X5.0 AWARD CRITERIA;

X5.1 Price per unit:

\$ 3955.00 per unit

X6.0 SPECIFICATIONS - GENERAL

X6.1 Manufacturer, model, series, and date of manufacture of proposed unit:

Wanco - Weco Solar Arrowboard 2009 New
Is descriptive literature, fully describing proposed unit attached to your bid? YES NO

If not, why? _____

X6.2 Will the required number of service manuals, and complete parts list be delivered to the Equipment Division at Buckhannon upon completion of delivery of total units?

YES NO

Will the required Equipment Preventive Maintenance Form (Section X6.2 of Bidders Evaluation Report) be provided upon inspection of the pilot unit?

YES NO

EQUIPMENT PREVENTATIVE MAINTENANCE QUESTIONNAIRE

THIS FORM MUST BE COMPLETED IN ITS ENTIRETY BY SUCCESSFUL BIDDER OR MANUFACTURER'S TECHNICAL REPRESENTATIVE PRIOR TO DELIVERY OF PILOT MODEL TO THE WVDOH.

DESCRIPTION: _____ MAKE: _____

MODEL: _____ YEAR: _____ PURCHASE AMOUNT: _____

ENGINE: MAKE: _____ MODEL: _____ FUEL TYPE: _____

HORSEPOWER: _____ CYLINDER: _____ ENGINE SERIAL: _____

COOLING SYSTEM CAPACITY: _____

BELTS: DESCRIPTION: _____ PART NUMBERS: _____

GVW: _____ AXLE CAPACITY: FRONT: _____ REAR: _____

TIRES: FRONT MAKE & SIZE: _____

REAR MAKE & SIZE: _____

DIMENSIONS OF UNIT: LENGTH: _____ WIDTH: _____ LENGTH: _____

VENDOR CONTACT PERSON: _____ PHONE: _____

PARTS:

BATTERY MAKE: _____ MODEL: _____ CCA: _____

TOP OR SIDE POST: _____ DIMENSIONS: LENGTH _____ WIDTH _____ HEIGHT _____

SPARK PLUGS OR FUEL INJECTORS MAKE: _____ PART # _____

FUEL PUMP OR INJECTION PUMP MAKE: _____ MODEL: _____

ALTERNATOR MAKE: _____ PART #: _____

STARTER MAKE: _____ PART #: _____

TURBO CHARGER MAKE: _____ PART #: _____

TRANS. MAKE: _____ MODEL: _____ AUTO/MANUAL: _____

HYDRAULIC PUMP MAKE: _____ MODEL: _____

FILTERS	MAKE	PART NO.	LUBRICANT	MANUFACTURER TYPE
OIL	_____	_____	ENGINE	_____
AIR INNER	_____	_____	TRANSMISSION	_____
AIR OUTER	_____	_____	POWER STEERING	_____
FUEL PRIMARY	_____	_____	HYDRAULIC	_____
FUEL SECONDARY	_____	_____	DIFFERENTIALS	_____
COOLANT	_____	_____	BRAKE FLUID	_____
HYDRAULIC	_____	_____	COOLANT	_____
OTHER	_____	_____	OTHER	_____

X6.3 TRAINING:

Will training seminar be conducted on Preventive Maintenance, Operator and Mechanic Training
 YES NO

Will you conduct training with each purchase order against this open end contract?
 YES NO

Will training be conducted within 2 working days from the delivery of the pilot unit on the individual purchase order?
 YES NO

If NO, explain time frame _____

Will an Operator's Manual be furnished directly to Training Academy prior to the delivery of the pilot?
 YES NO

X6.4 If you are the successful vendor, will you furnish all training aids, i.e., videos, projectors, required in conducting the training?
 YES NO

X6.4.1 Will all manuals, booklets, etc. explaining preventive maintenance, operator procedures, and service schedule be delivered with each unit?
 YES NO
 If NO, explain _____

X6.5 WARRANTY AND SERVICE POLICY

Will the warranty and service you provide comply with all areas as stated in Section 6.5 of specifications
 YES NO

Is warranty literature attached?
 YES NO

Is a minimum two (2) year bumper to bumper basic parts and labor warranty excluding abuse and normal wear items included?
 YES NO

Describe:

Wanco will provide a 2 year basic parts and labor warranty.

X6.6 EVALUATION COMMITTEE REQUIREMENTS

Is all component specifications, product literature, component models provided for Evaluation Committee bid determination? YES NO

X6.7 Will all parts, equipment, accessories, material, design and performance characteristics not specified herein, but which are necessary to provide a complete unit, be furnished with the unit and conform in strength, quality of material, and quality of workmanship to those which are advertised and provided to the market in general by the unit industry? YES NO

X6.7.1 Are all parts and accessories adequate and regularly supplied as standard to be included except those which may be duplications of specifications herein, and except these by specification are not to be furnished? YES NO

X6.7.2 Are all standard safety features that are required by Federal and State statutes of law included? YES NO

X7.0 SPECIFICATIONS OF THE QUOTED UNIT

The bidder should complete the following schedule in order for the Division to compare the actual bid unit to the specifications. Should the bidder except a requirement, then such exception may be only on the basis that such feature is not offered by the manufacturer. The Division will have the sole discretion as to whether the bidder's substitution meets the requirements of the specifications.

Does unit have built in auxiliary battery charger which would enable batteries to be hooked up to an AC power source at the storage yard or off of a generator in the field YES NO

Is charge time and charger version based on manufacturer's battery configuration YES NO

Describe: The DLS-15 converts nominal 108-132 AC voltage to 13.4 DC voltage for DC load operation and 12 volt battery charging

Manufacturer: Iota Engineering Model: DLS-15-Mod

X7.1 Arrowboard:

X7.1.1 Is the arrowboard panel weather-tight: YES NO

Describe weather-tight design and materials used:

Lockable weather-resistant Aluminium enclosure.

Arrow Board panel dimensions: ~~48~~ inches high x 96 inches wide

48

- X7.1.2 Height from bottom of panel to roadway 6.9 feet above roadway
- X7.1.3 Is the face of the panel flat black, with fifteen (15) hooded lamps?
 YES NO
- X7.1.3.1 Does lamp have five (5) inch amber LED with minimum angularity of 33 degrees
 YES NO
- X7.1.4 Modes of operation capability:
- X7.1.4.1 Right arrow – 10 lamps flashing in unison YES NO
- X7.1.4.2 Left arrow – 10 lamps flashing in unison YES NO
- X7.1.4.3 Double arrow – 5 lamps in each arrowhead and 3 lamps in shaft, all flashing in unison YES NO
- X7.1.4.4 Warning bar – 7 horizontal lamps flashing in unison YES NO
- X7.1.4.5 Four Point Caution – 4 outermost corner lamps flashing in unison YES NO
- X7.1.4.6 Indicator lights on back of panel YES NO
- X7.1.5 Is the unit flash rate 30 flashes per minute with a flash cycle time of two (2) seconds with 50 percent on time?
 YES NO
- X7.1.6 Will the unit reduce lamp brightness when the ambient light level drops below five (5) foot candles, plus or minus one (1) foot candle, and increase lamp brightness when the ambient light level increases to five (5) foot candles, plus or minus one (1) foot candle?
 YES NO
- X7.1.7 Unit's minimum distance of legibility: 1 mile(s)
- X7.2 Electrical System:
- X7.2.1 Does the solar generator incorporate a 12 Volt DC photovoltaic solar panel mounted on a self-erecting automatic positioning device located above the unit?
 YES NO
- X7.2.2 Is the battery bank of sufficient size and capacity to power the unit for 30 days without solar assist?
 YES NO
- X7.2.3 Are the batteries protected in a manner that will prevent damage due to overcharging or discharging to deeply at any temperature?
 YES NO

- X7.2.4 Does the unit have an external warning light, or other warning signal device, to indicate when the unit is in need of auxiliary charging prior to arrow shutoff?
 YES NO
- X7.2.5 Is the battery compartment vented, protected by an acid-resistant finish, and lockable?
 YES NO
- X7.2.6 Is the arrowboard controller housed in a lockable weatherproof enclosure?
 YES NO
- X7.2.7 Is unit safe guarded from any unwanted outside RF interference which would include but not be limited to VHF/FM receiver, 2-way radio receiver, cell phones, etc.
 YES NO
- X7.2.8 Is the unit equipped with an operational hour meter?
 YES NO
- X7.3 Trailer:
- X7.3.1 Is the trailer equipped with the following:
- X7.3.1.1 2,000 lb. axle with leaf springs YES NO
- X7.3.1.2 Tubeless standard tread tires and wheels YES NO
- X7.3.1.3 Heavy duty pintle eye hitch YES NO
- X7.3.1.4 Adjustable jack stand on trailer tongue YES NO
- X7.3.1.5 Adjustable jack stands to stabilize unit while in operation
 YES NO
- X7.3.1.6 Approved lighting and safety chains for highway use YES NO
- X7.3.1.7 Heavy duty light wiring for towing of unit with quick disconnect plug Cole Hersee Part Number 12081 male or equal
 YES NO
- X7.3.1.8 License plate brackets YES NO
- X7.3.1.9 Wheel fenders YES NO
- X7.3.1.10 Arrowboard raised and lowered using a hand operating winch (or hydraulic pump/ram) locked into place using latches of steel pins with keeper chains permanently attached to the unit
 YES NO

X7.4 Paint:

X7.4.1 Describe proposed method of painting the unit: Powder Coated and oven baked

X7.5 Does the proposed unit meet or exceed the "Occupational Safety and Health Act of 1970" requirements and/or any subsequent changes at the time manufactured?

YES NO

X7.6 Does the unit conform to advertising guidelines?

YES NO

X7.7 List all other standard features considered as standard equipment but not specifically addressed in the specifications: Batteries are fully sealed and will not leak or spill.

They require NO maintenance, resulting in longer battery life.

These batteries take less time to recharge - 5 to 6 hours instead of 24 hours. (This is with-out auxiliary battery charger)

X7.8 Preventive Maintenance and Operator's Training School:

Will a preventative maintenance and operator's training seminar be provided with each order?

YES NO

If you are the successful vendor, will you furnish all training aids, i.e., videos, projectors, required in conducting the training?

YES NO

Will all manuals, booklets, etc. preventive maintenance, operator procedures, and service schedule be delivered with each unit?

YES NO

If NO, explain _____

Have you attached a copy of the proposed program with your bid, stating the time required to perform the program and brief description of program YES NO

VENDOR PREFERENCE CERTIFICATE

Certification and application* is hereby made for Preference in accordance with West Virginia Code, §5A-3-37. (Does not apply to construction contracts). West Virginia Code, §5A-3-37, provides an opportunity for qualifying vendors to request (at the time of bid) preference for their residency status. Such preference is an evaluation method only and will be applied only to the cost bid in accordance with the West Virginia Code. This certificate for application is to be used to request such preference. The Purchasing Division will make the determination of the Resident Vendor Preference, if applicable.

- 1. Application is made for 2.5% resident vendor preference for the reason checked: Bidder is an individual resident vendor and has resided continuously in West Virginia for four (4) years immediately preceding the date of this certification; or, Bidder is a partnership, association or corporation resident vendor and has maintained its headquarters or principal place of business continuously in West Virginia for four (4) years immediately preceding the date of this certification; or 80% of the ownership interest of Bidder is held by another individual, partnership, association or corporation resident vendor who has maintained its headquarters or principal place of business continuously in West Virginia for four (4) years immediately preceding the date of this certification; or, Bidder is a nonresident vendor which has an affiliate or subsidiary which employs a minimum of one hundred state residents and which has maintained its headquarters or principal place of business within West Virginia continuously for the four (4) years immediately preceding the date of this certification; or,
2. Application is made for 2.5% resident vendor preference for the reason checked: Bidder is a resident vendor who certifies that, during the life of the contract, on average at least 75% of the employees working on the project being bid are residents of West Virginia who have resided in the state continuously for the two years immediately preceding submission of this bid; or,
3. Application is made for 2.5% resident vendor preference for the reason checked: Bidder is a nonresident vendor employing a minimum of one hundred state residents or is a nonresident vendor with an affiliate or subsidiary which maintains its headquarters or principal place of business within West Virginia employing a minimum of one hundred state residents who certifies that, during the life of the contract, on average at least 75% of the employees or Bidder's affiliate's or subsidiary's employees are residents of West Virginia who have resided in the state continuously for the two years immediately preceding submission of this bid; or,
4. Application is made for 5% resident vendor preference for the reason checked: Bidder meets either the requirement of both subdivisions (1) and (2) or subdivision (1) and (3) as stated above; or,
5. Application is made for 3.5% resident vendor preference who is a veteran for the reason checked: Bidder is an individual resident vendor who is a veteran of the United States armed forces, the reserves or the National Guard and has resided in West Virginia continuously for the four years immediately preceding the date on which the bid is submitted; or,
6. Application is made for 3.5% resident vendor preference who is a veteran for the reason checked: Bidder is a resident vendor who is a veteran of the United States armed forces, the reserves or the National Guard, if, for purposes of producing or distributing the commodities or completing the project which is the subject of the vendor's bid and continuously over the entire term of the project, on average at least seventy-five percent of the vendor's employees are residents of West Virginia who have resided in the state continuously for the two immediately preceding years.

Bidder understands if the Secretary of Revenue determines that a Bidder receiving preference has failed to continue to meet the requirements for such preference, the Secretary may order the Director of Purchasing to: (a) reject the bid; or (b) assess a penalty against such Bidder in an amount not to exceed 5% of the bid amount and that such penalty will be paid to the contracting agency or deducted from any unpaid balance on the contract or purchase order.

By submission of this certificate, Bidder agrees to disclose any reasonably requested information to the Purchasing Division and authorizes the Department of Revenue to disclose to the Director of Purchasing appropriate information verifying that Bidder has paid the required business taxes, provided that such information does not contain the amounts of taxes paid nor any other information deemed by the Tax Commissioner to be confidential.

Under penalty of law for false swearing (West Virginia Code, §61-5-3), Bidder hereby certifies that this certificate is true and accurate in all respects; and that if a contract is issued to Bidder and if anything contained within this certificate changes during the term of the contract, Bidder will notify the Purchasing Division in writing immediately.

Bidder: Logan Corporation Signed: Joseph M. Shields
Date: 10/5/09 Title: Territory Mgr.

*Check any combination of preference consideration(s) indicated above, which you are entitled to receive.

STATE OF WEST VIRGINIA
Purchasing Division

PURCHASING AFFIDAVIT

VENDOR OWING A DEBT TO THE STATE:

West Virginia Code §5A-3-10a provides that: No contract or renewal of any contract may be awarded by the state or any of its political subdivisions to any vendor or prospective vendor when the vendor or prospective vendor or a related party to the vendor or prospective vendor is a debtor and the debt owed is an amount greater than one thousand dollars in the aggregate.

PUBLIC IMPROVEMENT CONTRACTS & DRUG-FREE WORKPLACE ACT:

If this is a solicitation for a public improvement construction contract, the vendor, by its signature below, affirms that it has a written plan for a drug-free workplace policy in compliance with Article 1D, Chapter 21 of the *West Virginia Code*. The vendor **must** make said affirmation with its bid submission. Further, public improvement construction contract may not be awarded to a vendor who does not have a written plan for a drug-free workplace policy in compliance with Article 1D, Chapter 21 of the *West Virginia Code* and who has not submitted that plan to the appropriate contracting authority in timely fashion. For a vendor who is a subcontractor, compliance with Section 5, Article 1D, Chapter 21 of the *West Virginia Code* may take place before their work on the public improvement is begun.

ANTITRUST:

In submitting a bid to any agency for the state of West Virginia, the bidder offers and agrees that if the bid is accepted the bidder will convey, sell, assign or transfer to the state of West Virginia all rights, title and interest in and to all causes of action it may now or hereafter acquire under the antitrust laws of the United States and the state of West Virginia for price fixing and/or unreasonable restraints of trade relating to the particular commodities or services purchased or acquired by the state of West Virginia. Such assignment shall be made and become effective at the time the purchasing agency tenders the initial payment to the bidder.

I certify that this bid is made without prior understanding, agreement, or connection with any corporation, firm, limited liability company, partnership or person or entity submitting a bid for the same materials, supplies, equipment or services and is in all respects fair and without collusion or fraud. I further certify that I am authorized to sign the certification on behalf of the bidder or this bid.

LICENSING:

Vendors must be licensed and in good standing in accordance with any and all state and local laws and requirements by any state or local agency of West Virginia, including, but not limited to, the West Virginia Secretary of State's Office, the West Virginia Tax Department, West Virginia Insurance Commission, or any other state agencies or political subdivision. Furthermore, the vendor must provide all necessary releases to obtain information to enable the Director or spending unit to verify that the vendor is licensed and in good standing with the above entities.

CONFIDENTIALITY:

The vendor agrees that he or she will not disclose to anyone, directly or indirectly, any such personally identifiable information or other confidential information gained from the agency, unless the individual who is the subject of the information consents to the disclosure in writing or the disclosure is made pursuant to the agency's policies, procedures and rules. Vendor further agrees to comply with the Confidentiality Policies and Information Security Accountability Requirements, set forth in <http://www.state.wv.us/admin/purchase/privacy/noticeConfidentiality.pdf>.

Under penalty of law for false swearing (*West Virginia Code* §61-5-3), it is hereby certified that the vendor affirms and acknowledges the information in this affidavit and is in compliance with the requirements as stated.

Vendor's Name: Logan Corporation
Authorized Signature: Joseph M. Swaldo Date: 10/5/09



State of West Virginia
 Department of Administration
 Purchasing Division
 2019 Washington Street East
 Post Office Box 50130
 Charleston, WV 25305-0130

Request for Quotation

RFQ NUMBER
 7010EC01

PAGE
 1

ADDRESS CORRESPONDENCE TO ATTENTION OF:
 MICHAEL AUSTIN
 304-558-2402

VENDOR:
 *709035033 01 304-623-5670
 LOGAN CORPORATION
 ROUTE 2 BOX 924
 CLARKSBURG WV 26301

SHIP TO:
 DIVISION OF HIGHWAYS
 EQUIPMENT DIVISION
 ROUTE 33
 BRUSHY FORK ROAD
 BUCKHANNON, WV
 26201 304-472-1750

DATE PRINTED	TERMS OF SALE	SHIP VIA	F.O.B.	FREIGHT TERMS
09/16/2009	Net 30	Motor Freight	Delivered	Pre-Paid

BID OPENING DATE: 10/07/2009 BID OPENING TIME: 01:30PM

LINE	QUANTITY	UOP	CAT NO	ITEM NUMBER	UNIT PRICE	AMOUNT
				ADDENDUM NO. 1		
				DELETE "PURCHASING CARD ACCEPTANCE" IN ITS ENTIRETY.		
				BID OPENING DATE AND TIME REMAINS 10/07/09 @ 1:30 P.M.		
				NO OTHER CHANGES.		
0001	1	EA		550-96	\$ 3955.00	\$ 3955.00 each
				TO PROVIDE TRAILER MOUNTED SOLAR POWERED AAROWBOARD		
***** THIS IS THE END OF RFQ 7010EC01 ***** TOTAL:						

SEE REVERSE SIDE FOR TERMS AND CONDITIONS

SIGNATURE: *Joseph M. Daulton* TELEPHONE: 304-641-2011 DATE: 10/5/09

TITLE: Territory Mgr. FEIN: 55-0219530 ADDRESS CHANGES TO BE NOTED ABOVE

WHEN RESPONDING TO RFQ, INSERT NAME AND ADDRESS IN SPACE ABOVE LABELED 'VENDOR'



5870 Tennyson Street, Arvada Colorado 80003 USA
800-972-0755 | www.wanco.com
303-427-5700
303-427-5725 fax

Date: October 5, 2009

To: Joe Dinaldoat

Company: Logan Corp

Fax: 304 623 5676

Phone:

From: Dan Myers

Phone: 303-427-5700

Email: dmyers@wanco.com

Pages: 3 w/cover

Re: Extended Warranty

CC: [Click here to view task](#)

Urgent For Review Please Comment Please Reply Please Recycle

Mr Dinaldoat,

Jeff Hilliard asked me to send over our standard warranty info. For this order, Wanco WILL extend the warranty to 2 years for WVDOT.

If you need further information or have any questions, please do not hesitate to contact myself of Jeff Hilliard.

Thank you very much!

Dan Myers
Sales and Marketing
Wanco Inc

[Traffic Safety](#)
[Law Enforcement](#)
[Security & Surveillance](#)
[Power and Light](#)

Standard Wanco Warranty

MANUFACTURER'S LIMITED WARRANTY

WANCO INC. (WANCO) warrants to the original user that each product of its manufacture is free from defects in material and workmanship if properly installed, serviced, and operated under normal conditions.

WANCO's obligation under this warranty is limited to correcting without charge at its factory any part or parts thereof which shall be returned to its factory prepaid within one year after being put into service or 12 months after purchase by the original user, whichever is earlier, and which upon examination shall disclose to WANCO's satisfaction to have been originally defective. In any event, warranty will not extend beyond one year (12 months) from the date of original purchase from WANCO.

Under the conditions described above, WANCO light towers are warranted for a period of two years after being put into service or 24 months after purchase by the original user or 2,000 hours of operation, whichever is earliest. In any event, warranty on WANCO light towers will not extend beyond two years (24 months) from the original purchase date from WANCO.

This warranty shall not apply to any WANCO product that must be replaced because of normal wear, that has been subject to misuse, negligence or accident, or that has been repaired or altered outside of WANCO's factory unless authorized by WANCO.

WANCO makes no warranties with respect to engines or other component parts or accessories not manufactured by WANCO, same being subject only to such warranties, if any, as may be made by their respective manufacturers. WANCO does warrant that it will put forth its best efforts on behalf of original users of its products to assure that such manufacturer's warranties are satisfactorily performed.

THIS WARRANTY, AND THE MANUFACTURER'S OBLIGATION HEREUNDER, IS IN LIEU OF ALL OTHER WARRANTIES, EXPRESS, IMPLIED, OR STATUTORY, INCLUDING ANY WARRANTIES OF MERCHANTABILITY OR FITNESS FOR A PARTICULAR PURPOSE, and all other obligations or liabilities including special or consequential damages or contingent liabilities arising out of the failure of any product or

part to operate properly. WANCO shall not be liable for any special, indirect, incidental or consequential damages whether in contract, tort, under any warranty or otherwise, beyond the warranty quoted herein for products or parts.

No person is authorized to give any other warranty or to assume any additional obligation on WANCO's behalf unless made in writing and signed by an officer of the Manufacturer.



Copyright © 2009 Wanco Inc. All rights reserved. Privacy policy

WECO™ Arrowboards

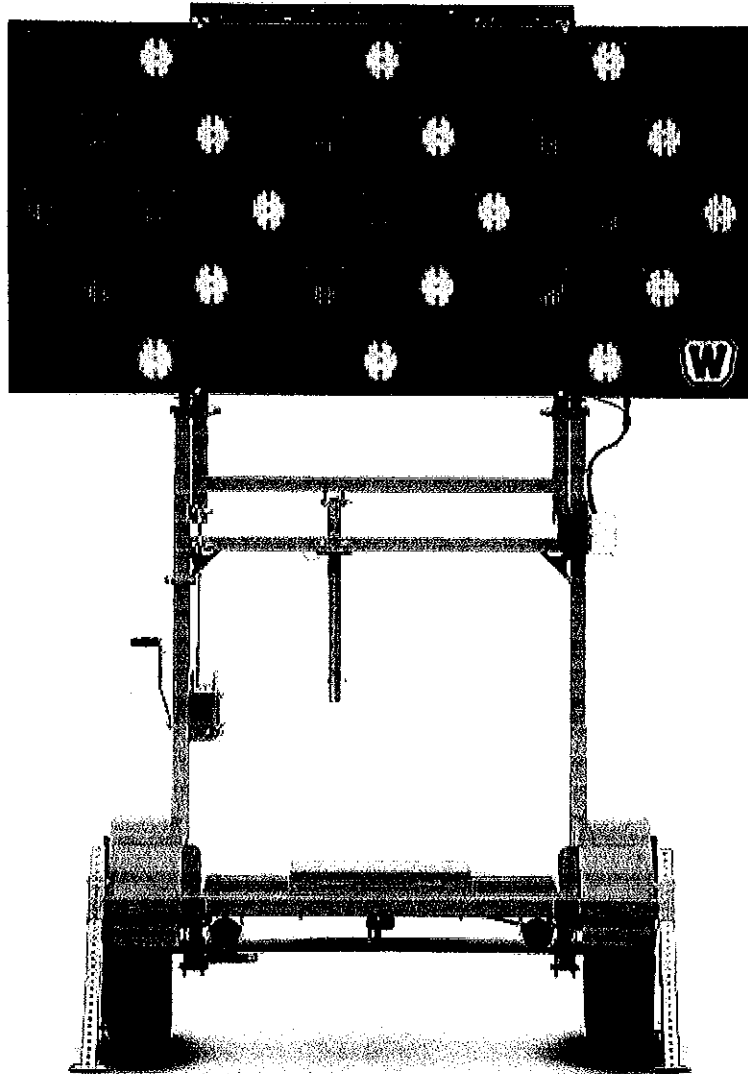

Orange for safety.
Green for the environment.

WANCO™ Driving traffic safety.

800-972-0755
www.wanco.com



Wanco's unique technology uses less power and smaller batteries, and is better for the environment.

- Consumes 66% less power
- Contains 80% less lead
- Sealed batteries will never leak or spill
- Reduced charging time saves energy

W|ECO™ Arrowboards are the most power-efficient in the industry. Through innovative engineering, this approach makes possible a unique power system that uses fewer and smaller batteries. The result is a remarkable new technology that benefits the environment without sacrificing performance.

Fewer and smaller batteries means less lead content—80% less, when compared to traditional arrowboards. The W|ECO batteries are fully sealed and will not leak or spill. They require no maintenance, resulting in longer battery life.

With a decrease in power consumption, these batteries take less time to charge—5 to 6 hours instead of 24—which not only saves energy but results in less downtime.

The total weight of the batteries has been reduced 210 pounds. As a result, towing a W|ECO Arrowboard saves fuel and the environment.

During the manufacturing process, powder coating emits near-zero volatile organic compounds (VOCs), and all over-spray is reclaimed and reused. Finally, nearly every component can be recycled.

More than just eco-friendly

Wanco arrowboards are designed to meet and exceed the highest standards of quality and performance in the industry.

A heavy-duty winch with safety brake allows one person to raise the arrowboard, and a single locking device holds the board in place. Constructed of rigid, tubular steel, all joints are welded. Bolt-on fenders can be replaced if damaged.

In the travel position, Wanco's unique design keeps the board horizontal without rear supports. This reduces the possibility of damage occurring during transport. The low-profile battery box improves visibility when backing.

For more information, call **800.972.0755** or visit wanco.com.



Brief specifications

Board material	Aluminum sheet and welded channels
Trailer construction	MIG welded 2½-inch square steel tubing
Coating	Powder coated and oven-baked
Controller	Self-contained solid state electronics located in lockable weather-resistant aluminum enclosure
Display options	15- or 25-light models provide up to 12 arrow display functions Automatic and manual dimming functions
Power system	3 or 4 sealed, leak- and spill-proof, 12-volt batteries Includes resetting dual circuit breakers, reverse polarity protection, and low-voltage disconnect Positive-drive voltage system applies voltage to lamps only when lit Contained in lockable weather-resistant enclosure
Industry standards	Meets MUTCD

Due to Wanco's commitment to continuous improvement of our products, all specifications and data are subject to change without notice. Wanco, W|ECO, "Orange for safety, Green for the environment," and the Wanco and W|ECO logos are trademarks of Wanco Inc.



WANCO INC.
5870 Tennyson Street
Arvada, Colorado 80003
800-972-0755
303-427-5700
303-427-5725 fax
www.wanco.com



➤ Traffic Safety

➤ Law Enforcement

➤ Security & Surveillance

➤ Power and Light

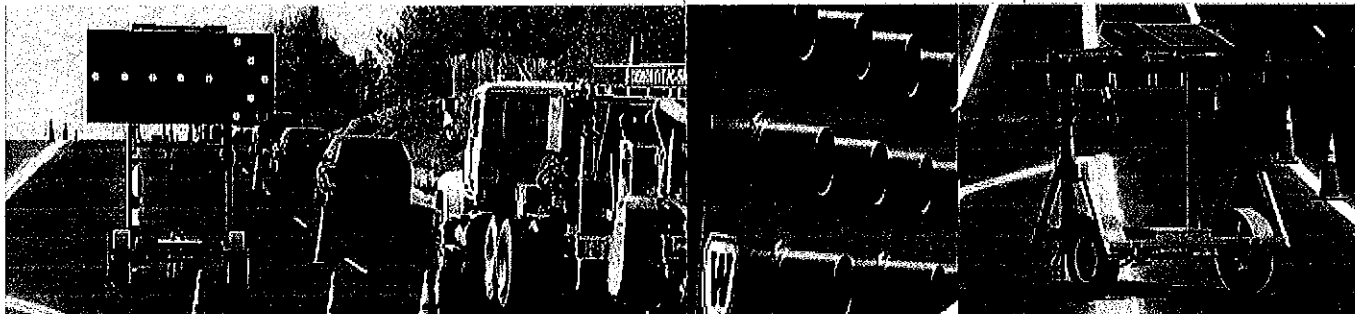

W|ECO Solar Arrow Boards

WTSP

W|ECO® Arrowboards are the most power-efficient in the industry. Innovative engineering makes possible a unique power system that uses smaller, more eco-friendly batteries. The result is a remarkable new technology that benefits the environment without sacrificing performance. W|ECO Arrowboards set the highest standards of quality and performance in the industry.

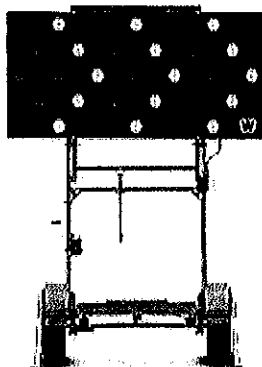

Features

Environmental

- Smaller batteries
- Consumes 66% less power than traditional solar arrow boards
- Smaller batteries have 80% less lead content
- Sealed batteries will not leak or spill and require no maintenance
- Decreased charging time saves energy and downtime
- Reduced battery weight saves fuel
- Manufacturing process emits near-zero VOCs
- Nearly every component can be recycled

Functional

- High-output amber LEDs legible up to 1 mile (1.6 km)
- Choose 15 lamps with 7 arrow display modes or 25 lamps with 12 arrow display modes
- Easy to operate and maintain
- Heavy-duty hand-winch with safety brake allows one person to raise board
- Single locking device holds arrow board in place while operating and during transport
- Controller located safely away from work zone traffic
- Weather resistant control box cover has lockable slam-latch
- Control box outputs have short-circuit protection, helping prevent blown transistors
- Positive-drive voltage system applies power to lamps only when lit
- Power system includes resetting dual circuit breakers, reverse polarity protection, and low-voltage disconnect
- 50-watt solar charging system features solid state voltage regulator with charge indicator
- Arrow display has automatic and manual dimming, with flash rates of 30 to 40 per minute
- Tires are standard 15-inch bias ply
- Lunette ring tow hitch for pintle hook
- In travel position, unique design supports board without rear braces, reducing possibility of damage during transport
- Durable powder-coat finish resists the elements
- Meets MUTCD
- NTPEP tested

Arrow display

Flashing Modes

Corner caution

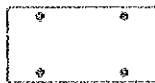

Caution bar



Left/right

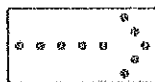

Double arrow

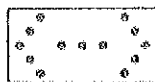

Sequential Modes

First pulse

Second pulse

Third pulse

Sequential stem arrow, left/right



Sequential arrow, left/right*

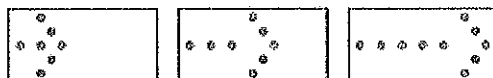

Sequential chevron arrow, left/right*



Alternating diamonds*



*Flashing rate, all models: 30 to 40 per minute.
Consult factory for optional arrow modes not shown.
* Available only on 25-light models.*

Options*

Solar wattage

- 65
- 85
- 130

Tow hitch

Combo-hitch for 2-inch ball or pintle hook
 Rear tow receiver

Other options

Manual dimming
 15-amp battery charger
 Auto-lock stabilizer pins

**Some options may not be available for aftermarket installation. Please consult factory.*

Specifications

Dimensions — inches (cm)

Travel Position

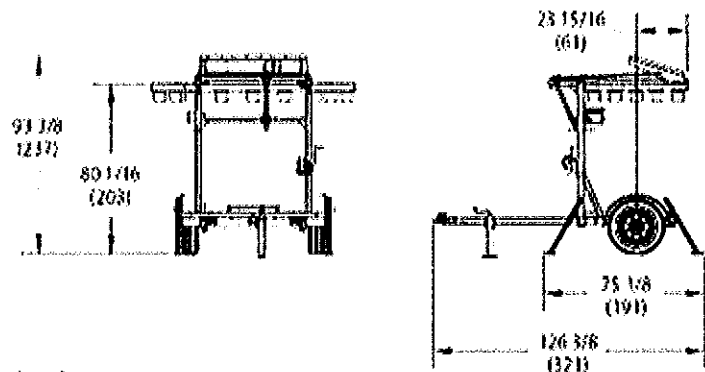

Deployed

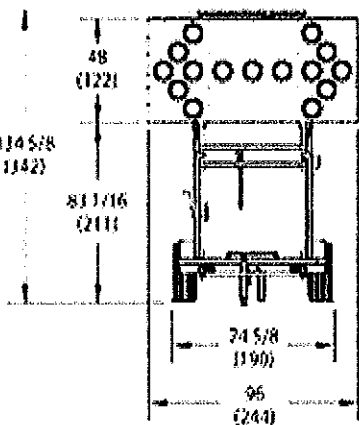

Weight

Approx. 990 lbs. (450 kg)

Construction

Trailer	MIG-welded, 2.5-inch square steel tubing
Arrow board	Aluminum sheet and welded channels
Coating	Powder-coated and oven-baked
Axle assembly	2000-lb. capacity tubular axle 5-hole 4.5-inch bolt circle pattern on idler hub 60-inch wheel track
Tires	Double eye leaf springs, 1200-lb. capacity per spring ST205/75 D15 trailer tires

Standards compliance

MUTCD type C

Power

Battery type	Sealed, leak- and spill-proof absorbed glass mat (AGM)
Battery voltage	12 V dc
Battery capacity	75-125 Ah total
Number of batteries	Three or four
Solar charging	One or two solar panels
Solar panel regulation	50 W on 15-light arrow boards, 85 W on 25-light arrow boards; charge controlled via arrow board control panel

Details

The W|ECO technology consumes less power and uses smaller batteries, resulting in greatly reduced lead content — 80% less, when compared to traditional arrow board batteries.

Additionally, W|ECO batteries are fully sealed and will not leak or spill, which is better for the environment. And because they require no maintenance, W|ECO batteries have a longer useful lifespan, saving costs associated with replacement.

With a decrease in power consumption, these batteries take less time to charge—4 to 5 hours instead of 24—which not only saves energy but results in less downtime.

The total weight of the battery bank has been reduced 210 pounds. As a result, towing a W|ECO Arrowboard saves fuel.

During the manufacturing process, powder coating emits near-zero volatile organic compounds (VOCs) , and nearly all over-spray is reclaimed and reused. Finally, nearly every component can be recycled.

More than just eco-friendly Wanco arrow boards are designed to meet and exceed the highest standards of quality and performance in the industry.

A heavy-duty winch with safety brake allows one person to raise the arrow board, and a single locking device holds the board in place. Constructed of rigid, tubular steel, all joints are welded. Bolt-on fenders can be replaced if damaged.

In the travel position, Wanco's unique design fully supports the board without rear braces. As a result, it never strikes another surface during transport. This innovation virtually eliminates the damage that other arrow boards endure.

Documents

W|ECO Arrowboard Brochure

Financing

Financing your capital equipment purchases means saving your cash for use in other ways. Builders, contractors and rental businesses across the country continue to use equipment financing to help simplify cost justification, increase margins and grow their enterprises.

[Learn More](#)



CLARKSBURG
212 NORTH OHIO AVENUE
RT. 2 BOX 924
CLARKSBURG, WV 26301
PHONE: (304) 623-5670
1-800-473-0110
FAX: (304) 623-5676
www.logancorp.com

The following will be covered in detail during the operator's training seminar on the Wanco Weco Solar Powered Arrowboard.

1. Description and Features of Unit
2. Safety and Precautions
3. Set-Up/Operating Instructions
4. Trailer Alignment
5. Winch Operating Instructions
6. Trouble Shooting

The Following will be covered in detail during the preventive maintenance portion of the training seminar on the Wanco Weco Solar Powered Arrowboard.

1. Periodic Maintenance
 - a. Array Maintenance
 - b. General Maintenance

The training seminar will take about 30 minutes to complete

Logan Corporation,
Joe Dinaldo