



State of West Virginia
 Department of Administration
 Purchasing Division
 2019 Washington Street East
 Post Office Box 50130
 Charleston, WV 25305-0130

Request for Quotation

RFQ NUMBER:
5890004

PAGE:
1

ADDRESS CORRESPONDENCE TO ATTENTION OF:
**MICHAEL AUSTIN
 304-558-2402**

RFQ COPY
 TYPE NAME/ADDRESS HERE

CHARLESTON BLUEPRINT, INC.
 1203 VIRGINIA STREET, EAST
 CHARLESTON, WV 25301-2908
 (304) 343-1063

**DIVISION OF HIGHWAYS
 VARIOUS LOCALES AS INDICATED
 BY ORDER**

DATE PRINTED	TERMS OF SALE	SHIP VIA	FOB	FREIGHT TERMS
05/26/2009				

BID OPENING DATE: **07/01/2009** BID OPENING TIME **01:30PM**

LINE	QUANTITY	UOP	CAT NO	ITEM NUMBER	UNIT PRICE	AMOUNT
0001	11	EA		938-31		
				ENGINEERING PRINTING SYSTEM		
0002	1	EA		205-41		
				WIDE FORMAT SCANNER		
<p>TO PROVIDE ELEVEN (11) ENGINEERING PRINTING SYSTEMS AND ONE (1) WIDE FORMAT SCANNER THAT WILL INCLUDE INSTALLATION, MAINTENANCE AND TRAINING FOR THE WEST VIRGINIA DIVISION OF HIGHWAYS PER THE ATTACHED SPECIFICATIONS.</p> <p>THERE WILL BE A MANDATORY PRE-BID CONFERENCE AT THE PURCHASING DIVISION, BUILDING 15, CONFERENCE ROOM, AT 10:00 AM ON 06/18/2009. FAILURE TO ATTEND THE PRE-BID WILL RESULT IN BID DISQUALIFICATION.</p> <p>QUESTIONS: WRITTEN QUESTIONS WILL BE ACCEPTED THROUGH CLOSE OF BUSINESS (5:00 EST.) ON THURSDAY, 06/11/09. SEND YOUR QUESTIONS TO: PURCHASING DIVISION ATTENTION MICHAEL AUSTIN 2019 WASHINGTON ST. E. CHARLESTON, WV 25305</p> <p>QUESTIONS MAY BE SENT VIA FAX, EMAIL, OR REGULAR MAIL. E-MAIL: MICHAEL.D.AUSTIN@WV.GOV FAX: 304-558-4115</p> <p>IT IS THE VENDORS RESPONSIBILITY TO VERIFY THAT THEIR QUESTIONS HAVE BEEN RECEIVED BY CALLING 304-558-2402.</p>						

SEE REVISED RFQ

2009 JUL -1 AM 9:25
 WV PURCHASING DIVISION

SEE REVERSE SIDE FOR TERMS AND CONDITIONS

SIGNATURE	TELEPHONE	DATE
TITLE	FEIN	ADDRESS CHANGES TO BE NOTED ABOVE

WHEN RESPONDING TO RFQ, INSERT NAME AND ADDRESS IN SPACE ABOVE LABELED 'VENDOR'

**GENERAL TERMS & CONDITIONS
REQUEST FOR QUOTATION (RFQ) AND REQUEST FOR PROPOSAL (RFP)**

1. Awards will be made in the best interest of the State of West Virginia.
2. The State may accept or reject in part, or in whole, any bid.
3. All quotations are governed by the *West Virginia Code* and the *Legislative Rules* of the Purchasing Division.
4. Prior to any award, the apparent successful vendor must be properly registered with the Purchasing Division and have paid the required \$125 fee.
5. All services performed or goods delivered under State Purchase Order/Contracts are to be continued for the term of the Purchase Order/Contracts, contingent upon funds being appropriated by the Legislature or otherwise being made available. In the event funds are not appropriated or otherwise available for these services or goods, this Purchase Order/Contract becomes void and of no effect after June 30.
6. Payment may only be made after the delivery and acceptance of goods or services.
7. Interest may be paid for late payment in accordance with the *West Virginia Code*.
8. Vendor preference will be granted upon written request in accordance with the *West Virginia Code*.
9. The State of West Virginia is exempt from federal and state taxes and will not pay or reimburse such taxes.
10. The Director of Purchasing may cancel any Purchase Order/Contract upon 30 days written notice to the seller.
11. The laws of the State of West Virginia and the *Legislative Rules* of the Purchasing Division shall govern all rights and duties under the Contract, including without limitation the validity of this Purchase Order/Contract.
12. Any reference to automatic renewal is hereby deleted. The Contract may be renewed only upon mutual written agreement of the parties.
13. **BANKRUPTCY:** In the event the vendor/contractor files for bankruptcy protection, the State may deem this contract null and void, and terminate such contract without further order.
14. **HIPAA BUSINESS ASSOCIATE ADDENDUM:** The West Virginia State Government HIPAA Business Associate Addendum (BAA), approved by the Attorney General, and available online at the Purchasing Division's web site (<http://www.state.wv.us/admin/purchase/vrc/hipaa.htm>) is hereby made part of the agreement. Provided that, the Agency meets the definition of a Cover Entity (45 CFR §160.103) and will be disclosing Protected Health Information (45 CFR §160.103) to the vendor.
15. **WEST VIRGINIA ALCOHOL & DRUG-FREE WORKPLACE ACT:** If this Contract constitutes a public improvement construction contract as set forth in Article 1D, Chapter 21 of the West Virginia Code ("The West Virginia Alcohol and Drug-Free Workplace Act"), then the following language shall hereby become part of this Contract: "The contractor and its subcontractors shall implement and maintain a written drug-free workplace policy in compliance with the West Virginia Alcohol and Drug-Free Workplace Act, as set forth in Article 1D, Chapter 21 of the West Virginia Code. The contractor and its subcontractors shall provide a sworn statement in writing, under the penalties of perjury, that they maintain a valid drug-free work place policy in compliance with the West Virginia and Drug-Free Workplace Act. It is understood and agreed that this Contract shall be cancelled by the awarding authority if the Contractor: 1) Fails to implement its drug-free workplace policy; 2) Fails to provide information regarding implementation of the contractor's drug-free workplace policy at the request of the public authority; or 3) Provides to the public authority false information regarding the contractor's drug-free workplace policy."

INSTRUCTIONS TO BIDDERS

1. Use the quotation forms provided by the Purchasing Division.
2. **SPECIFICATIONS:** Items offered must be in compliance with the specifications. Any deviation from the specifications must be clearly indicated by the bidder. Alternates offered by the bidder as **EQUAL** to the specifications must be clearly defined. A bidder offering an alternate should attach complete specifications and literature to the bid. The Purchasing Division may waive minor deviations to specifications.
3. Complete all sections of the quotation form.
4. Unit prices shall prevail in case of discrepancy.
5. All quotations are considered F.O.B. destination unless alternate shipping terms are clearly identified in the quotation.
6. **BID SUBMISSION:** All quotations must be delivered by the bidder to the office listed below prior to the date and time of the bid opening. Failure of the bidder to deliver the quotations on time will result in bid disqualifications: Department of Administration, Purchasing Division, 2019 Washington Street East, P.O. Box 50130, Charleston, WV 25305-0130



State of West Virginia
 Department of Administration
 Purchasing Division
 2019 Washington Street East
 Post Office Box 50130
 Charleston, WV 25305-0130

Request for Quotation

RFQ NUMBER:
 5890004

PAGE:
 2

ADDRESS CORRESPONDENCE TO ATTENTION OF:
 MICHAEL AUSTIN
 304-558-2402

VENDOR

RFQ COPY
 TYPE NAME/ADDRESS HERE

SHIP TO

DIVISION OF HIGHWAYS
 VARIOUS LOCALES AS INDICATED
 BY ORDER

DATE PRINTED	TERMS OF SALE	SHIP VIA	FOB	FREIGHT TERMS
05/26/2009				

BID OPENING DATE: 07/01/2009 BID OPENING TIME 01:30PM

LINE	QUANTITY	UOP	CAT NO	ITEM NUMBER	UNIT PRICE	AMOUNT
<p>THE MODEL/BRAND/SPECIFICATIONS NAMED HEREIN ESTABLISH THE ACCEPTABLE LEVEL OF QUALITY ONLY AND ARE NOT INTENDED TO REFLECT A PREFERENCE OR FAVOR ANY PARTICULAR BRAND OR VENDOR. VENDORS WHO ARE BIDDING ALTERNATES SHOULD SO STATE AND INCLUDE PERTINENT LITERATURE AND SPECIFICATIONS. FAILURE TO PROVIDE INFORMATION FOR ANY ALTERNATES MAY BE GROUNDS FOR REJECTION OF THE BID. THE STATE RESERVES THE RIGHT TO WAIVE MINOR IRREGULARITIES IN BIDS OR SPECIFICATIONS IN ACCORDANCE WITH SECTION 148-1-4(F) OF THE WEST VIRGINIA LEGISLATIVE RULES AND REGULATIONS.</p> <p>EXHIBIT 10</p> <p>REQUISITION NO.: 5890004</p> <p>ADDENDUM ACKNOWLEDGEMENT</p> <p>I HEREBY ACKNOWLEDGE RECEIPT OF THE FOLLOWING CHECKED ADDENDUM(S) AND HAVE MADE THE NECESSARY REVISIONS TO MY PROPOSAL, PLANS AND/OR SPECIFICATION, ETC.</p> <p>ADDENDUM NO.'S:</p> <p>NO. 1 T.S.</p> <p>NO. 2</p> <p>NO. 3</p> <p>NO. 4</p> <p>NO. 5</p>						

SEE REVERSE SIDE FOR TERMS AND CONDITIONS

SIGNATURE _____ TELEPHONE _____ DATE _____

TITLE _____ FEIN _____ ADDRESS CHANGES TO BE NOTED ABOVE

WHEN RESPONDING TO RFQ, INSERT NAME AND ADDRESS IN SPACE ABOVE LABELED 'VENDOR'



State of West Virginia
 Department of Administration
 Purchasing Division
 2019 Washington Street East
 Post Office Box 50130
 Charleston, WV 25305-0130

Request for Quotation

RFQ NUMBER
 5890004

PAGE
 3

ADDRESS CORRESPONDENCE TO ATTENTION OF
 MICHAEL AUSTIN
 304-558-2402

RFQ COPY
 TYPE NAME/ADDRESS HERE

DIVISION OF HIGHWAYS
 VARIOUS LOCALES AS INDICATED
 BY ORDER

DATE PRINTED	TERMS OF SALE	SHIP VIA	F.O.B.	FREIGHT TERMS
05/26/2009				

BID OPENING DATE: 07/01/2009 BID OPENING TIME 01:30PM

LINE	QUANTITY	UOP	CAT NO	ITEM NUMBER	UNIT PRICE	AMOUNT
<p>I UNDERSTAND THAT FAILURE TO CONFIRM THE RECEIPT OF THE ADDENDUM(S) MAY BE CAUSE FOR REJECTION OF BIDS.</p> <p>VENDOR MUST CLEARLY UNDERSTAND THAT ANY VERBAL REPRESENTATION MADE OR ASSUMED TO BE MADE DURING ANY ORAL DISCUSSION HELD BETWEEN VENDOR'S REPRESENTATIVES AND ANY STATE PERSONNEL IS NOT BINDING. ONLY THE INFORMATION ISSUED IN WRITING AND ADDED TO THE SPECIFICATIONS BY AN OFFICIAL ADDENDUM IS BINDING.</p> <p style="text-align: right;"> <i>Justin Dill</i> SIGNATURE CHARLESTON BLUEPRINT COMPANY 6/30/09 DATE </p> <p>REV. 11/96</p> <p style="text-align: center;">NOTICE</p> <p>A SIGNED BID MUST BE SUBMITTED TO:</p> <p style="text-align: center;"> DEPARTMENT OF ADMINISTRATION PURCHASING DIVISION BUILDING 15 2019 WASHINGTON STREET, EAST CHARLESTON, WV 25305-0130 </p> <p>THE BID SHOULD CONTAIN THIS INFORMATION ON THE FACE OF</p>						

SEE REVERSE SIDE FOR TERMS AND CONDITIONS			
SIGNATURE <i>Justin Dill</i>	TELEPHONE 304-343-1063	DATE 6/30/09	
TITLE SALES MANAGER	FEIN 550691159	ADDRESS CHANGES TO BE NOTED ABOVE	

WHEN RESPONDING TO RFQ, INSERT NAME AND ADDRESS IN SPACE ABOVE LABELED 'VENDOR'



State of West Virginia
 Department of Administration
 Purchasing Division
 2019 Washington Street East
 Post Office Box 50130
 Charleston, WV 25305-0130

Request for Quotation

RFQ NUMBER
 5890004

PAGE
 4

ADDRESS CORRESPONDENCE TO ATTENTION OF
 MICHAEL AUSTIN
 304-558-2402

VENDOR

RFQ COPY
 TYPE NAME/ADDRESS HERE

SHIP TO

DIVISION OF HIGHWAYS
 VARIOUS LOCALES AS INDICATED
 BY ORDER

DATE PRINTED	TERMS OF SALE	SHIP VIA	FOB	FREIGHT TERMS
05/26/2009				

BID OPENING DATE: 07/01/2009 BID OPENING TIME 01:30PM

LINE	QUANTITY	UQP	CAT NO	ITEM NUMBER	UNIT PRICE	AMOUNT
THE ENVELOPE OR THE BID MAY NOT BE CONSIDERED: SEALED BID						
BUYER:				33		
RFQ. NO.:				5890004		
BID OPENING DATE:				-----		
BID OPENING TIME:				-----		
PLEASE PROVIDE A FAX NUMBER IN CASE IT IS NECESSARY TO CONTACT YOU REGARDING YOUR BID:						
CONTACT PERSON (PLEASE PRINT CLEARLY):				-----		
***** THIS IS THE END OF RFQ 5890004 ***** TOTAL:						

*SEE REVISED
RFQ*

SEE REVERSE SIDE FOR TERMS AND CONDITIONS						
SIGNATURE			TELEPHONE		DATE	
TITLE		FEIN		ADDRESS CHANGES TO BE NOTED ABOVE		

WHEN RESPONDING TO RFQ, INSERT NAME AND ADDRESS IN SPACE ABOVE LABELED 'VENDOR'

Engineering Printing Systems Specifications

1) General Intent:

The following specifications are for the acquisition, installation, and maintenance of eleven Engineering Printing Systems, and one wide format Scanner. These Engineering Printing Systems must be fully integrated systems which shall satisfactorily plot/print/scan/copy CADD Drawings, GIS Files, PDF documents, TIFF images, Maps, Charts, Graphs, and Text Documents. It is the intent to place one complete system in each of the ten WVDOT District Headquarters, one complete system at the Materials Division, and the one wide format Scanner is to be setup and installed at the WVDOT Headquarters Building

1.1) General Description of the Engineering Digital Printing System:

In brief, each printing system shall consist of (see Attachment 3):

- One color plotter that shall accommodate media up to 36 inches wide, and
- One toner based monochrome plotter that shall accommodate media up to 36 inches wide, and
- One scanner that shall accommodate media up to 36 inches wide, and the scanner shall be able to make color and monochrome scans and copies, and a
- Controller unit that shall be integrated with the color plotter, the monochrome plotter, and the scanner.
- All components shall be Bentley InterPlot compatible.
- One year of maintenance shall be included in the quoted price for each system.

1.2) General Description of the Scanner for the WVDOT Headquarters Building:

The Headquarters Building currently has an Engineering Digital Printing System in place; therefore, a full scale printing system is not required at this location. However, this location does need a wide format Scanner that can interface with the WVDOT computer network, can produce color and monochrome scans, and place the scan files on an FTP site or a Shared Drive for later retrieval and/or printing.

2) Specific Requirements for Each of the Major Components – Digital Printing System.

2.1) Minimum Mandatory Specifications for the Color Plotter:

- Ability to produce Color and Monochrome prints.
- Ability to produce prints while the ink cartridges are being changed.
- Ability to produce prints while the media is being changed.
- Printer resolution of 600 dpi.
- Have at least three different Quality Modes (i.e., Low, Medium, and High).
- Allow the User to define the Quality Mode.
- Have the plotter automatically be able to change the quality mode as necessary to produce prints of high quality but that minimize ink usage.
- Produce one, color, "E" size print per 60 seconds.
- Produce one, Monochrome, "E" size drawing per 60 seconds.
- Be equipped with Two Rolls.
- Ability to switch rolls manually and/or automatically.
- Roll media widths from 11 inches to 36 inches.
- Print documents that are 8 inches to 120 inches long.
- Maximum roll length of 300 feet.
- Print to Bond, Vellum, and Mylar media.
- Ability to define what media is being used in each roll.
- Have the capability to cut prints to size according to the following options: a Standard size (i.e., ANSI or ARCH); and/ or the size of the print; and/ or to a User defined size.

Engineering Printing Systems Specifications

- Use standard 120 VAC, 60Hz power.
- 2.2) **Minimum Mandatory Specifications for the Monochrome Plotter:**
- Printer resolution of 600 dpi.
 - Ability to print ten linear feet per minute, or produce two "E" size Monochrome prints per minute in all print modes.
 - Two Rolls of Media.
 - Allow the User to select either Manual Feed or Roll Feed media.
 - Roll media widths from 11 inches to 36 inches.
 - Print documents that are 8 inches to 120 inches long.
 - Roll length of up to 300 feet.
 - Print to Bond, Vellum, and Mylar media.
 - Ability to define what media is being used in each roll.
 - Have the capability to cut prints to size according to the following options: a Standard size (i.e., ANSI or ARCH); and/ or the size of the print; and/ or to a User defined size.
 - Use standard 120 VAC, 60Hz power.
- 2.3) **Minimum Mandatory Scanner Specifications:**
- Ability to properly interface with the WVDOT computer network.
 - Ability to place scanned files on an FTP site or a Shared Drive of a server.
 - Ability to produce Color or Monochrome scans.
 - Produce scanned files in 'tiff' and 'pdf' format.
 - Adjustable scanner resolution not exceeding 600 dpi.
 - Scan documents that contain lines and text, blueprints, dark originals, photographs, or transparent documents.
 - Scan documents 8 inches wide to 36 inches wide.
 - Scan documents that are 8 inches to 120 inches long.
 - Automatic exposure adjustment.
 - Use standard 120 VAC, 60Hz power.
- **Note 1:** in the case of the ten WVDOT District Offices and the Materials Division, the Scanner shall be electronically connected to the Controller Unit (see paragraph 2.6) in order to electronically retrieve scanned documents and/or make copies of them.
 - **Note 2:** in the case of the one Scanner which will be installed at the WVDOT Headquarters Building, the Scanner shall be electronically connected with the WVDOT computer network in order to retrieve scanned documents and/or make copies of them.
- 2.4) **Minimum Mandatory Controller Specifications:**
- Make copies (1 to 999) from a single scan.
 - Make copies (1 to 999) from a scan set.
 - Allow the User to define the input mode of documents to be copied (Single, Collated Set, or Multiple Sheets).
 - Allow the User to define the Zoom setting (10% to 1000%) so that documents can be made larger or smaller as needed.
 - Allow the User to define the Exposure setting so that documents can be made lighter or darker as needed.
 - Provide an Invert option which allows the user to convert a scanned image to a negative image. For black and white images, the white pixels will be printed black and the black pixels will be printed white. For grayscale images, the image will be converted into its photographic negative.

Engineering Printing Systems Specifications

7

- Allow the User to define the Media to be used when making copies (Roll 1 or Roll 2).
- Produce image files (TIFF, PDF, and CALS formats) from scans.
- Support the following file formats: HPGL, HPGL2, HPRTL, TIFF 6.0, and PostScript.
- Produce prints while documents are being scanned.
- Automatically rotate documents when the scan width is larger than the media width.
- Automatically provide each scanned document with a unique name.
- Job Queuing.
- Electronically Collate Job Sets.
- Have a Bentley InterPlot Driver available.
- Print Management Tools.
- Document Submission Tools.
- Document Retrieval Tools.
- Ethernet Interface 100/10 Mbits/s with RJ45 Connection.
- Must be able to simultaneously Print, Copy, and Scan.
- Support the TCP/IP FTP, and Novell (IPX/SPX) Network Protocols.
- Provide Automatic Roll Selection and Roll Switching.

3) Other Requirements:

3.1) Start up supplies shall be provided and included in the quote, for each of the eleven (11) systems:

- Provide one box of toner for each Monochrome Plotter.
- Provide one box of color cartridges for each Color Plotter.
- Provide one roll of paper media (150' x 34") for the Monochrome Plotter.
- Provide one roll of paper media (150' x 34") for the Color Plotter.
- Provide one copy of the User Manual and other product documentation, either printed or 'pdf format is acceptable.
- **Note:** Since a complete system will not be installed at the Headquarters Building, that location does not require media, toner, or cartridges; however, this location shall require a copy of the User Manual and other product documentation for the Scanner which will be installed there. Additionally this location will require a copy of the Digital Engineering Printing System User Manual and other product documentation.

3.2) Training:

- Onsite training on the use of the new equipment shall be provided and included in the quote as further described, for: each District Office location, at the Materials Division Office, and at the Headquarters Building.
- A minimum of two (2) hours training shall be provided at each location.
- Training shall include showing the users how the new equipment is used.
- Training shall include showing the users how to load and change media.
- Training shall include showing the users how to load toner in the Monochrome Plotter.
- Training shall include showing the users how to install the ink cartridges in the Color Plotter.
- **Note:** Since a complete system will not be installed at the Headquarters Building, that location does not require training in changing media and ink cartridges; however, user training for the Scanner unit installed at that location shall be required.

Engineering Printing Systems Specifications

3.3) Maintenance Requirements – Mandatory:

- Vendors' quotes shall include Onsite maintenance of all components.
- A maximum four (4) hour call back response to the initial reported problem.
- One (1) business day onsite response time shall be required – calculated from time of initial reported problem.
- One (1) year of maintenance – calculated from the completion of the Training Date at each location for each system shall be included in the equipment system quotes.
- Each vendor shall provide additional quotes (separate from the equipment quotes) for four (4) consecutive maintenance renewal options. Maintenance quotes for Years' Two thru Years' Five shall be quoted separately- by year. These renewal maintenance quotes shall be based on the same maintenance requirements as defined in this RFQ. All maintenance expenses are to be invoiced in arrears.
- Maintenance shall include Preventive Maintenance calls as required to maintain the equipment components within the manufacturer's original specifications.
- Maintenance shall include replacement parts, including drums at no additional expense.
- Maintenance shall include travel and other related expenses incurred during maintenance calls.
- All replacement parts shall be made with Original Equipment Manufacturer (OEM) Parts.

3.4) Installation Requirements – *each system*:

- All systems described in this RFQ shall be delivered, installed, set-up, tested, and fully functional within forty-five (45) days of vendor receiving an approved order.
- All components shall be delivered freight prepaid to each of the twelve (12) locations specified on Attachment 2.
- The vendor shall provide a minimum two (2) day notice of all equipment deliveries.
- The vendor shall be responsible for equipment installation, set-up, and removal/disposal of all packing materials.
- The vendor shall have the option of removing trade-in equipment or not taking possession of it.
- The vendor shall register all equipment components with the manufacturer so that the owner and user of the equipment are listed as WVDOT.
- Upon payment in whole, all rights, title, and interest to the equipment components shall transfer to the WVDOT.

4) Award process:

The award for the Digital Engineering Printing Systems RFQ shall be made to the vendor that provides a solution which features a Color Plotter, a Monochrome Plotter, a Scanner capable of producing both Color and Monochrome Scans, and a Controller Unit that electronically links all of the various components and meets all the mandatory requirements of this RFQ at the least expense to the WVDOT.

- Vendors should include with each quote, a statement which lists successful implementation of the same (as proposed/quoted) equipment components in an integrated environment of North American Engineering application(s). Contact name(s) (associated with the engineering entity) and telephone number(s) should also be provided.
- Vendors must include in their proposal/bid, a Trade-In Quote for the currently used Xerox 8825 Scanner/Plotter (10) units as listed on Attachment 2.

Engineering Printing Systems Specifications

Attachment 1: Bid/Quote Sheet

11 Monochrome Plotters.....	UNIT PRICE	EXTENDED PRICE
11 Color Plotters.....	UNIT PRICE	EXTENDED PRICE
12 Scanners.....	UNIT PRICE	EXTENDED PRICE
11 Controllers.....	UNIT PRICE	EXTENDED PRICE
Equipment Sub Total.....		
MAINTENANCE QUOTES YEARS 2 thru YEARS 5:		
Year 2 Maintenance Cost	Year 3 Maintenance Cost	
Year 4 Maintenance Cost	Year 5 Maintenance Cost	
Years 2 thru 5 Maintenance Sub Total.....		
Equipment/Maintenance Total.....		
Lump Sum Trade-In Discount.....		
FINAL Quote Total.....		

Statement regarding successful implementation of quoted components in an integrated environment of Engineering application in North America. Also provide contact name(s) and telephone number(s) associated with the engineering application of the quoted components.

REVISED

Engineering Printing Systems Specifications

10

Attachment 2: Delivery, Installation, Setup, and Training Locations -

District 1

1334 Smith Street
Charleston, WV 25301-1492
District Manager
John McBrayer
(304)558-3001
Xerox 8825 Plotter/Scanner currently in use at this location,
Serial Number: DT9031090

District 2

801 Madison Avenue
Huntington, WV 25712-0880
District Manager
Keith Chapman
(304)528-5625
Xerox 8825 Plotter/Scanner currently in use at this location,
Serial Number: DT9031269

District 3

624 Depot Street
Parkersburg, WV 26102-0308
District Engineer
James E. Roten, Jr.
(304)420-4645
Xerox 8825 Plotter/Scanner currently in use at this location,
Serial Number: DT9031273

District 4

I-79 & Meadowbrook Road (Exit 121)
Clarksburg, WV 26302-2570
District Manager
Greg Phillips
(304)842-1550
Xerox 8825 Plotter/Scanner currently in use at this location,
Serial Number: DT9030880

District 5

P. O. Box 99 (US Route 50)
Burlington, WV 26710
District Engineer
Lee Thorne
(304)289-2200
Xerox 8825 Plotter/Scanner currently in use at this location,
Serial Number: DT9031065

District 6

1 DOT Drive
Moundsville, WV 26041
District Engineer
Robert W. Whipp
(304)843-4008
Xerox 8825 Plotter/Scanner currently in use at this location,
Serial Number: DT9031070

Engineering Printing Systems Specifications

11

Attachment 2: Delivery, Installation, Setup, and Training Locations -

District 7
255 Depot Street
Weston, WV 26452-1228
Highway District Manager
Ron Hooton
304-269-0414
Xerox 8825 Plotter/Scanner currently in use at this location,
Serial Number: DT9030950

District 8
US Route 219 North
P.O. Box 1516
Elkins, WV 26241
District Engineer
Mike Moran
(304)637-0220
Xerox 8825 Plotter/Scanner currently in use at this location,
Serial Number: DT9031021

District 9
103 1/2 Church Street
Lewisburg, WV 24901
District Engineer
Steven Cole
(304)647-7450
Xerox 8825 Plotter/Scanner currently in use at this location,
Serial Number: DT9031255

District 10
270 Hardwood Lane
Princeton, WV 24740
District Manager
Tom Camden
(304)487-5228
Xerox 8825 Plotter/Scanner currently in use at this location,
Serial Number: DT9031178

Materials Division
190 Dry Branch Road
Charleston, WV 25306
Division Director
Aaron Gillespie
(304)558-3160
Removal and/or Trade-in of old equipment is not required at this location.

WVDOT Headquarters
1900 Kanawha Blvd, East
Charleston, WV 25305
Information Services Director
Joe Biancaniello
(304)558-9241
Removal and/or Trade-in of old equipment is not required at this location.

Attachment 3: Diagram of the Engineering Printing System --

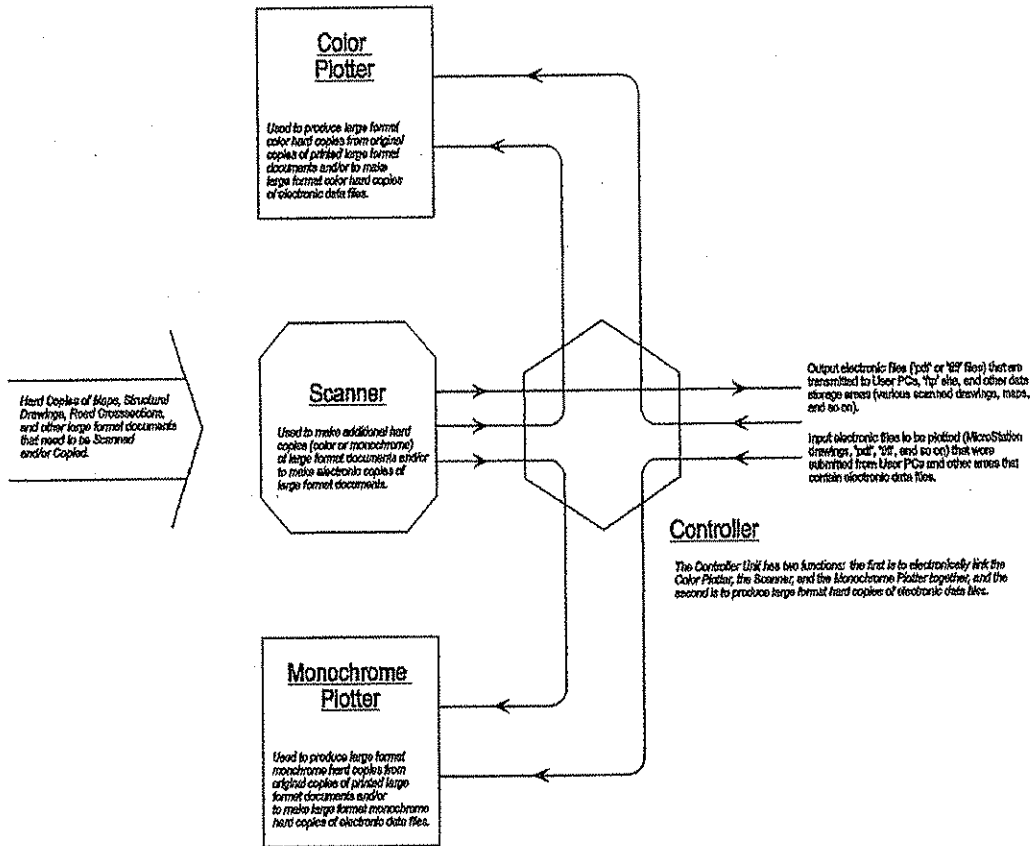

VENDOR PREFERENCE CERTIFICATE

Certification and application* is hereby made for Preference in accordance with West Virginia Code, §5A-3-37. (Does not apply to construction contracts). West Virginia Code, §5A-3-37, provides an opportunity for qualifying vendors to request (at the time of bid) preference for their residency status. Such preference is an evaluation method only and will be applied only to the cost bid in accordance with the West Virginia Code. This certificate for application is to be used to request such preference. The Purchasing Division will make the determination of the Resident Vendor Preference, if applicable.

- 1. Application is made for 2.5% resident vendor preference for the reason checked: Bidder is an individual resident vendor and has resided continuously in West Virginia for four (4) years immediately preceding the date of this certification; or, Bidder is a partnership, association or corporation resident vendor and has maintained its headquarters or principal place of business continuously in West Virginia for four (4) years immediately preceding the date of this certification; or 80% of the ownership interest of Bidder is held by another individual, partnership, association or corporation resident vendor who has maintained its headquarters or principal place of business continuously in West Virginia for four (4) years immediately preceding the date of this certification; or, Bidder is a nonresident vendor which has an affiliate or subsidiary which employs a minimum of one hundred state residents and which has maintained its headquarters or principal place of business within West Virginia continuously for the four (4) years immediately preceding the date of this certification; or,
2. Application is made for 2.5% resident vendor preference for the reason checked: Bidder is a resident vendor who certifies that, during the life of the contract, on average at least 75% of the employees working on the project being bid are residents of West Virginia who have resided in the state continuously for the two years immediately preceding submission of this bid; or,
3. Application is made for 2.5% resident vendor preference for the reason checked: Bidder is a nonresident vendor employing a minimum of one hundred state residents or is a nonresident vendor with an affiliate or subsidiary which maintains its headquarters or principal place of business within West Virginia employing a minimum of one hundred state residents who certifies that, during the life of the contract, on average at least 75% of the employees or Bidder's affiliate's or subsidiary's employees are residents of West Virginia who have resided in the state continuously for the two years immediately preceding submission of this bid; or,
4. Application is made for 5% resident vendor preference for the reason checked: Bidder meets either the requirement of both subdivisions (1) and (2) or subdivision (1) and (3) as stated above; or,
5. Application is made for 3.5% resident vendor preference who is a veteran for the reason checked: Bidder is an individual resident vendor who is a veteran of the United States armed forces, the reserves or the National Guard and has resided in West Virginia continuously for the four years immediately preceding the date on which the bid is submitted; or,
6. Application is made for 3.5% resident vendor preference who is a veteran for the reason checked: Bidder is a resident vendor who is a veteran of the United States armed forces, the reserves or the National Guard, if, for purposes of producing or distributing the commodities or completing the project which is the subject of the vendor's bid and continuously over the entire term of the project, on average at least seventy-five percent of the vendor's employees are residents of West Virginia who have resided in the state continuously for the two immediately preceding years.

Bidder understands if the Secretary of Revenue determines that a Bidder receiving preference has failed to continue to meet the requirements for such preference, the Secretary may order the Director of Purchasing to: (a) reject the bid; or (b) assess a penalty against such Bidder in an amount not to exceed 5% of the bid amount and that such penalty will be paid to the contracting agency or deducted from any unpaid balance on the contract or purchase order.

By submission of this certificate, Bidder agrees to disclose any reasonably requested information to the Purchasing Division and authorizes the Department of Revenue to disclose to the Director of Purchasing appropriate information verifying that Bidder has paid the required business taxes, provided that such information does not contain the amounts of taxes paid nor any other information deemed by the Tax Commissioner to be confidential.

Under penalty of law for false swearing (West Virginia Code, §61-5-3), Bidder hereby certifies that this certificate is true and accurate in all respects; and that if a contract is issued to Bidder and if anything contained within this certificate changes during the term of the contract, Bidder will notify the Purchasing Division in writing immediately.

Bidder: CHARLESTON BLUEPRINT Signed: [Signature]
Date: 6/30/09 Title: SALES MANAGER

*Check any combination of preference consideration(s) indicated above, which you are entitled to receive.

STATE OF WEST VIRGINIA
Purchasing Division**PURCHASING AFFIDAVIT****VENDOR OWING A DEBT TO THE STATE:**

West Virginia Code §5A-3-10a provides that: No contract or renewal of any contract may be awarded by the state or any of its political subdivisions to any vendor or prospective vendor when the vendor or prospective vendor or a related party to the vendor or prospective vendor is a debtor and the debt owed is an amount greater than one thousand dollars in the aggregate.

PUBLIC IMPROVEMENT CONTRACTS & DRUG-FREE WORKPLACE ACT:

If this is a solicitation for a public improvement construction contract, the vendor, by its signature below, affirms that it has a written plan for a drug-free workplace policy in compliance with Article 1D, Chapter 21 of the *West Virginia Code*. The vendor **must** make said affirmation with its bid submission. Further, public improvement construction contract may not be awarded to a vendor who does not have a written plan for a drug-free workplace policy in compliance with Article 1D, Chapter 21 of the *West Virginia Code* and who has not submitted that plan to the appropriate contracting authority in timely fashion. For a vendor who is a subcontractor, compliance with Section 5, Article 1D, Chapter 21 of the *West Virginia Code* may take place before their work on the public improvement is begun.

ANTITRUST:

In submitting a bid to any agency for the state of West Virginia, the bidder offers and agrees that if the bid is accepted the bidder will convey, sell, assign or transfer to the state of West Virginia all rights, title and interest in and to all causes of action it may now or hereafter acquire under the antitrust laws of the United States and the state of West Virginia for price fixing and/or unreasonable restraints of trade relating to the particular commodities or services purchased or acquired by the state of West Virginia. Such assignment shall be made and become effective at the time the purchasing agency tenders the initial payment to the bidder.

I certify that this bid is made without prior understanding, agreement, or connection with any corporation, firm, limited liability company, partnership or person or entity submitting a bid for the same materials, supplies, equipment or services and is in all respects fair and without collusion or fraud. I further certify that I am authorized to sign the certification on behalf of the bidder or this bid.

LICENSING:

Vendors must be licensed and in good standing in accordance with any and all state and local laws and requirements by any state or local agency of West Virginia, including, but not limited to, the West Virginia Secretary of State's Office, the West Virginia Tax Department, West Virginia Insurance Commission, or any other state agencies or political subdivision. Furthermore, the vendor must provide all necessary releases to obtain information to enable the Director or spending unit to verify that the vendor is licensed and in good standing with the above entities.

CONFIDENTIALITY:

The vendor agrees that he or she will not disclose to anyone, directly or indirectly, any such personally identifiable information or other confidential information gained from the agency, unless the individual who is the subject of the information consents to the disclosure in writing or the disclosure is made pursuant to the agency's policies, procedures and rules. Vendor further agrees to comply with the Confidentiality Policies and Information Security Accountability Requirements, set forth in <http://www.state.wv.us/admin/purchase/privacy/noticeConfidentiality.pdf>.

Under penalty of law for false swearing (*West Virginia Code* §61-5-3), it is hereby certified that the vendor affirms and acknowledges the information in this affidavit and is in compliance with the requirements as stated.

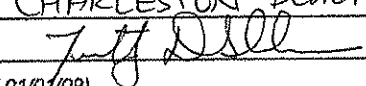
Vendor's Name: CHARLESTON BLUEPRINT
 Authorized Signature:  Date: 6/30/09



State of West Virginia
 Department of Administration
 Purchasing Division
 2019 Washington Street East
 Post Office Box 50130
 Charleston, WV 25305-0130

Request for Quotation

RFQ NUMBER
 5890004

PAGE
 1

ADDRESS CORRESPONDENCE TO ATTENTION OF
 MICHAEL AUSTIN
 304-558-2402

*709060257 304-343-1063
 CHARLESTON BLUEPRINT
 1203 VIRGINIA STREET EAST
 CHARLESTON WV 25301-2908

DIVISION OF HIGHWAYS
 VARIOUS LOCALES AS INDICATED
 BY ORDER

DATE PRINTED	TERMS OF SALE	SHIP VIA	F.O.B.	FREIGHT TERMS
06/24/2009				

BID OPENING DATE: 07/01/2009 BID OPENING TIME 01:30PM

LINE	QUANTITY	UOP	CAT NO	ITEM NUMBER	UNIT PRICE	AMOUNT
ADDENDUM NO. 1						
REVISED SPECIFICATIONS ATTACHED.						
BID OPENING DATE AND TIME REMAINS 07/01/09 @ 1:30 P.M.						
NO OTHER CHANGES.						
0001	11	EA		938-31	SEE PAGE 3	FOR BREAKDOWN
				ENGINEERING PRINTING SYSTEM		
0002	1	EA		205-41		
				WIDE FORMAT SCANNER		
***** THIS IS THE END OF RFQ 5890004 ***** TOTAL:						\$410,289 ⁰⁰
						GOOD FOR 30 DAYS

SEE REVERSE SIDE FOR TERMS AND CONDITIONS

SIGNATURE: *[Signature]* TELEPHONE: 304-343-1063 DATE: 6/30/09

TITLE: SALES MANAGER FEIN: 550691159 ADDRESS CHANGES TO BE NOTED ABOVE

WHEN RESPONDING TO RFQ, INSERT NAME AND ADDRESS IN SPACE ABOVE LABELED 'VENDOR'

WV DOT REQUISITION 5890004 - ENGINEERING PRINTING SYSTEMS
ADDENDUM TO SPECIFICATIONS

June 23, 2009

Item 1.2) General Description of the Scanner for the WVDOT Headquarters Building:

Add the following statement: *A scanner stand shall be quoted with this one scanner unit.*

Item 2.1) Minimum Mandatory Specifications for the Color Plotter:

Previously Read: Maximim roll length of 300 feet

Changed to Read: Accept roll lengths of 150 feet to 500 feet.

Item 2.2) Minimum Mandatory Specifications for the Monochrome Plotter:

Previously Read: Roll length up to 300 feet

Changed to Read: Accept roll lengths of 150 feet to 500 feet.

Item 2.3) Minimum Mandatory Scanner Specifications:

Note 2: Add the following statement at the end of this Note: *A scanner stand will be quoted with this one scanner .*

Item 3.4) Installation Requirements - each system

2nd Bullet - Previously Read: All components shall be delivered freight prepaid to each of the twelve (12) locations specified on Attachment 2.

2nd Bullet - Changed to Read: *All components shall be delivered freight prepaid to each of the twelve (12) locations specified on Attachment 2. Deliveries must be made to an inside/protected location.*

Item 4) Award Process

Previously Read: The award for the Digital Engineering Printing Systems RFQ shall be made to the vendor that provides a solution which features a Color Plotter, a Monochrome Plotter, a Scanner capable of producing both Color and Monochrome Scans, and a Controller Unit that electronically links all of the various components and meets all the mandatory requirements of this RFQ at the least expense to the WVDOT.

Changed to Read: *The award for the Digital Engineering Printing Systems RFQ shall be made to the vendor that provides a solution which features a Color Plotter, a Monochrome Plotter, a Scanner capable of producing both Color and Monochrome Scans, and a Controller Unit that electronically links all of the various components and meets all the mandatory requirements, including maintenance for the five year period of this RFQ at the least expense to the WVDOT.*

See Revised Attachment 1 and Attachment 2 as attached.

Engineering Printing Systems Specifications

Attachment 1: Bid/Quote Sheet
Rev. 6/23/09

Océ PW300 MONOCHROME PLOTTER /COLOR SCANNER
HP4520 COLOR PLOTTER
Océ CS4336 COLOR STAND ALONE SCANNER

11 Monochrome Plotters.....	UNIT PRICE	10,085 ⁰⁰		EXTENDED PRICE	110,935 ⁰⁰
11 Color Plotters.....	UNIT PRICE	10,463 ⁰⁰		EXTENDED PRICE	115,093 ⁰⁰
11 Scanners.....	UNIT PRICE	3,826 ⁰⁰		EXTENDED PRICE	42,086 ⁰⁰
1 WF Scanner w/stand.....	UNIT PRICE	8,295 ⁰⁰		EXTENDED PRICE	8,295 ⁰⁰
11 Controllers.....	UNIT PRICE	N/A		EXTENDED PRICE	N/A
Equipment Sub Total.....					276,409⁰⁰

MAINTENANCE QUOTES YEARS 2 thru YEARS 5:

Year 2 Maintenance Cost	30,445 ⁰⁰	Year 3 Maintenance Cost	32,333 ⁰⁰	
Year 4 Maintenance Cost	34,409 ⁰⁰	Year 5 Maintenance Cost	36,693 ⁰⁰	
Years 2 thru 5 Maintenance Sub Total.....				133,880⁰⁰
Equipment/Maintenance Total.....				410,289⁰⁰
Lump Sum Trade-In Discount				
FINAL Quote Total.....				410,289⁰⁰

Statement regarding successful implementation of quoted components in an integrated environment of Engineering application in North America. Also provide contact name(s) and telephone number(s) associated with the engineering application of the quoted components.

Engineering Printing Systems Specifications

Attachment 2: Delivery, Installation, Setup, and Training Locations - Rev. 06/23/09

District 1

1334 Smith Street

Charleston, WV 25301-1492

Loading Dock - Elevator - up to 2,000 lbs. 35" Door

District Manager

John McBrayer

(304)558-3001

Xerox 8825 Plotter/Scanner currently in use at this location,

Serial Number: DT9031090

Currently - semi-operational condition

District 2

801 Madison Avenue

Huntington, WV 25712-0880

Loading Dock - Elevator - up to 5,000 lbs. - 36" Doors

District Manager

Keith Chapman

(304)528-5625

Xerox 8825 Plotter/Scanner currently in use at this location,

Serial Number: DT9031269

Currently - operational condition

District 3

624 Depot Street

Parkersburg, WV 26102-0308

29 Steps - No elevator - 36" Doors

District Engineer

James E. Roten, Jr.

(304)420-4645

Xerox 8825 Plotter/Scanner currently in use at this location,

Serial Number: DT9031273

Currently - semi-operational condition

District 4

I-79 & Meadowbrook Road (Exit 121)

Clarksburg, WV 26302-2570

No Stairs - Elevator - up to 2000 lbs. - 36" Doors

District Manager

Greg Phillips

(304)842-1550

Xerox 8825 Plotter/Scanner currently in use at this location,

Serial Number: DT9030880

Currently - non operational condition

District 5

P. O. Box 99 (US Route 50)

Burlington, WV 26710

No Steps - No Elevator - Ground Floor - 36" Doors

District Engineer

Lee Thorne

(304)289-2200

Xerox 8825 Plotter/Scanner currently in use at this location,

Serial Number: DT9031065

Currently - operational condition

District 6

1 DOT Drive

Moundsville, WV 26041

No Steps - Elevator - up to 2,500 lbs. - 42" Door

District Engineer

Robert W. Whipp

(304)843-4008

Xerox 8825 Plotter/Scanner currently in use at this location,

Serial Number: DT9031070

Currently - operational condition

Engineering Printing Systems Specifications

Attachment 2: Delivery, Installation, Setup, and Training Locations - Rev. 06/23/09

District 7

255 Depot Street

Weston, WV 26452-1228

Approximately 6 steps – No elevator – 36" Doors

Highway District Manager

Ron Hooton

304-269-0400

Xerox 8825 Plotter/Scanner currently in use at this location,

Serial Number: DT9030950 Currently - operational condition

District 8

US Route 219 North

P.O. Box 1516

Elkins, WV 26241

No Steps – Elevator – up to 2,000 lbs. 36" Doors

District Engineer

Mike Moran

(304)637-0220

Xerox 8825 Plotter/Scanner currently in use at this location,

Serial Number: DT9031021 Currently – operational condition

District 9

103 1/2 Church Street

Lewisburg, WV 24901

Approximately 8 steps – No elevator – 36" Doors

District Engineer

Steven Cole

(304)647-7450

Xerox 8825 Plotter/Scanner currently in use at this location,

Serial Number: DT9031255 Currently – operational condition

District 10

270 Hardwood Lane

Princeton, WV 24740

No Steps – Elevator – up to 2,000 lbs. – 36" Doors

District Manager

Tom Camden

(304)487-5228

Xerox 8825 Plotter/Scanner currently in use at this location,

Serial Number: DT9031178 Currently – operational condition

Materials Division

190 Dry Branch Road

Charleston, WV 25306

Loading Dock – Ground Floor – 36" Doors

Division Director

Aaron Gillespie

(304)558-3160

Removal and/or Trade-in of old equipment is not required at this location.

WVDOT Headquarters

1900 Kanawha Blvd, East

Charleston, WV 25305

Loading Dock – Elevator – up to 3,500 lbs. – 36" Doors

Information Services Director

Joe Biancaniello

(304)558-9241

Removal and/or Trade-in of old equipment is not required at this location.

Charleston Blueprint references for quoted equipment for RFQ 5890004

MSES Consultants (TDS450 with HP4500 Plotter)

609 West Main Street

Clarksburg, WV 26301

Attn: Larry Rine

1-304-624-9700

Brookfield Energy (Oce TDS450 with OCE TCS300 Plotter)

326 Third Avenue

Montgomery, WV 25136

Attn: Larry Kesterson

1-304-442-5120 ext. 7252

The Oce PlotWave300 is a "New" single footprint device manufactured utilizing the same technology that has proven to be User Friendly, Reliable and Energy Conscious for over fifteen years. We have multiple customers in West Virginia (including WVDOH) who have implemented this technology and continue to use it with minimal downtime (average about two service calls per year). Due to the fact that the Plotwave300 has just been introduced (April 2009) we cannot, at this time, provide a user who can reference this exact piece of equipment.

Maintenance fees include 10,000 sqft per month on monochrome with .04 sqft overage charge per machine.

Maintenance does not include consumables such as print heads, ink cartridges, toner or paper.



Océ PlotWave 300 system

Join the next wave



Simple, green, durable, all-in-one large format system
Printing, copying and scanning large format technical documents just got easier for everyone. The next wave of Océ monochrome multifunctional systems starts with the Océ PlotWave® 300 system. It cuts energy usage in half, fits in small spaces and turns out page after page of nearly flawless documents—without missing a beat. And with the design, construction, and reliability you've come to expect from Océ.

The next wave in simplicity: easy to use yet powerful; flexible integration with your workflow

Print and scan documents at the system with a USB® flash drive. Easily switch rolls on the fly with automated roll changing. Feed originals in face-up with digital width recognition for fewer scanning errors. Say goodbye to damaged prints and backaches with the top delivery tray. Simple but powerful job submission and print management. Easy integration into your IT infrastructure.

The next wave in green technology: cut energy usage in half

Conventional roller-based systems have long warm-up and cool-down periods, which waste time and energy. Eco-friendly Océ Radiant Fusing technology is designed specifically to provide the most efficient

means of fusing toner onto paper. Thin metallic tiles made of a highly durable alloy are used to optimally radiate heat, fusing the toner onto the paper. They heat up and cool down very quickly. That means the system starts up instantly, uses half the energy of comparable systems, makes no noise when it is idling, and requires no extra ventilation to keep it cool. Thanks to a catalytic convertor system virtually no ozone emissions are produced. All in all, the low noise, heat, and ozone emissions means a healthier working environment.

The next wave in durability: makes your money go further

The Océ PlotWave 300 system is constructed of solid, hard wearing materials that are designed to make it last longer than comparable systems. Critical components, such as the imaging drum and other moving parts, are completely enclosed to reduce contamination and wear and tear. High use parts, like the paper drawers and panels, are

made of reinforced materials to further extend the system's lifetime. The result—a system built to withstand the demands of many users, ideal for a walk-up printing environment.

The next wave in quality: improves your image

Océ Color Image Logic technology automatically produces high quality scans without complex user interaction. Océ high resolution pico printing technology enables you to consistently produce drawings with fine details, sharp lines and text, and smooth area fills. The right formula for professional results and happier customers.

Fits anywhere

The compact green design of the Océ PlotWave 300 system is ideal if you have limited room. It fits in small spaces and does not require ventilation or an extra large table for stacking.

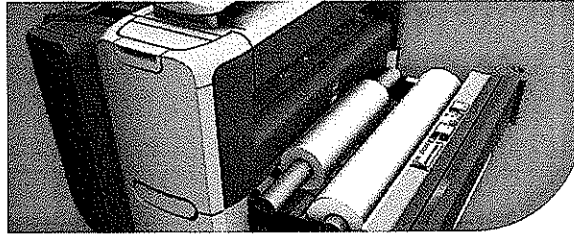
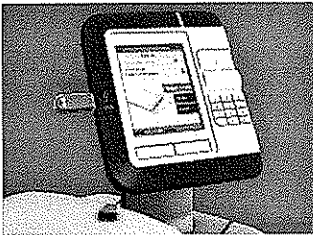

General

Description
Type
Speed
Warm-up time
Configurations
Roll options
Output delivery
Power consumption

Monochrome wide format print/copy/scan system with color scanner
 Electrophotography (LED) with organic photoconductor (OPC) and closed toner system
 4 D/minute, FPOT (First Print Output Time) from Sleep 42s for a D-size
 Instant with Océ Radiant Fusing technology
 Printer or multifunction (print, copy, scan) 1 or 2 rolls
 1-2 rolls
 Compact and ergonomic top delivery tray with air separation; up to 50 E-size plots collated
 Active mode: 1.2 kw / Ready mode: 64w

Printer

Print resolution
Paper capacity
Output sizes width
Output sizes length
Paper weight
Media type
 (www.océusa.com/imagingsupplies)

600 x 1200 dpi
 Up to 650 ft., max. 2 rolls
 11" x 36"
 16.5" to 49.2"
 18-28 lb. bond
 Paper: plain, recycled, colored and transparent; Film: polyester, antistatic and contrast

Controller

Controller type
Memory
Hard drive
Page description language

Océ PowerM™ controller with Windows XP® Embedded
 1 GB
 160 GB
 HP-GL, HP-GL/2, TIFF, JPEG, DWF, PS/PDF-option, CALS, NIFF, NIRS, ASCII, Calcomp 906/907/951, C4

Scanner

Scanner type
Scan resolution
Scan speed
Scan format
Scan destination
Original size width/length
Original thickness
Scaling
Preset modes

Contact Image Sensor (CIS) with Océ Color Image Logic technology
 600 x 600 dpi optical resolution
 Up to 23 linear ft./min. (copying) and 38 linear ft./min. (monochrome scanning)
 TIFF, PDF, JPEG, CALS
 Local USB flash drive, controller, network via FTP or SMB
 8.2"-36" / 8.2"-630"
 Up to 0.03"
 Scale to standard format, custom scale 10-1000%
 Lines & text, lines & text draft, colored, photo, dark originals, blueprint

Print, copy and scan workflow

General workflow
Submission
Job management
Templates

Concurrent print, copy and scan of single documents or sets
 Single files: Local USB flash drive, Microsoft® certified Windows® driver, Adobe® PostScript®3 driver; Sets of files: with integrated web based job submission Océ Publisher Express
 Océ Express WebTools single interface to view and control the system via an Internet browser without the need to install additional software; Monitor and manage the system status, settings, network configurations, updates, includes Smart Inbox
 Enables recurring tasks to be performed at the touch of a single button. User defined four copy and scan templates

Options

Hardware
Software

Océ Scanner Express, integrated on top color scanner for copying and scanning
 Additional roll unit (max. 2 rolls per printer)
 Color user interface available early 2010
 Adobe PostScript 3/PDF file interpreter. Enables the submission of PDF files with USB flash drive or job submission tools directly to the printer



Océ helps the people who make our world. Companies everywhere use Océ high-speed printing, technical documentation, and professional document systems to keep the wheels of business, industry and government turning. Océ also helps the world. Developing products and services that add value to the document processes of our customers, while minimizing environmental impact and protecting health and safety, has always been one of our core principles. From bank statements to utility bills, from blueprints to newspapers, from on-demand documents to wide-format display graphics, Océ helps our professional customers go "Beyond the Ordinary" in print and document management.

Océ North America

Wide Format Printing Systems
 5450 North Cumberland Avenue
 Chicago, Illinois 60656
 1-800-714-4427
 1-773-714-4076
 Fax 1-773-714-4056
 email: us.info@oce.com

Océ-Canada Inc.
 4711 Yonge Street, Suite 1100
 Toronto, Ontario, M2N 6K8
 Canada
 1-800-668-1945
 Fax 1-416-224-5778
 email: info.ca@oce.com

Océ Mexico, S.A. de C.V.
 Ave. Pol. Paseo de la
 Reforma No. 1236 Piso 4
 Mexico City, DF 05348
 52-55-5089-8700
 email: mex.info@oce.com

For information and services, visit us at:
www.océusa.com

© 2009 Océ. Illustrations and specifications do not necessarily apply to products and services offered in each local market. Technical specifications are subject to change without prior notice. The Océ logo, "Océ," and "Océ PlotWave" are registered trademarks of Océ-Technologies B.V. "Océ PowerM" is a trademark of Océ-Technologies B.V. "USB" is a registered trademark of USB Corporation. "Microsoft," "Windows," and "Windows XP" are registered trademarks of Microsoft Corporation. "Adobe" and "Postscript," are registered trademarks of Adobe Systems, Inc. All other trademarks are the property of their owners, and are respectfully acknowledged.

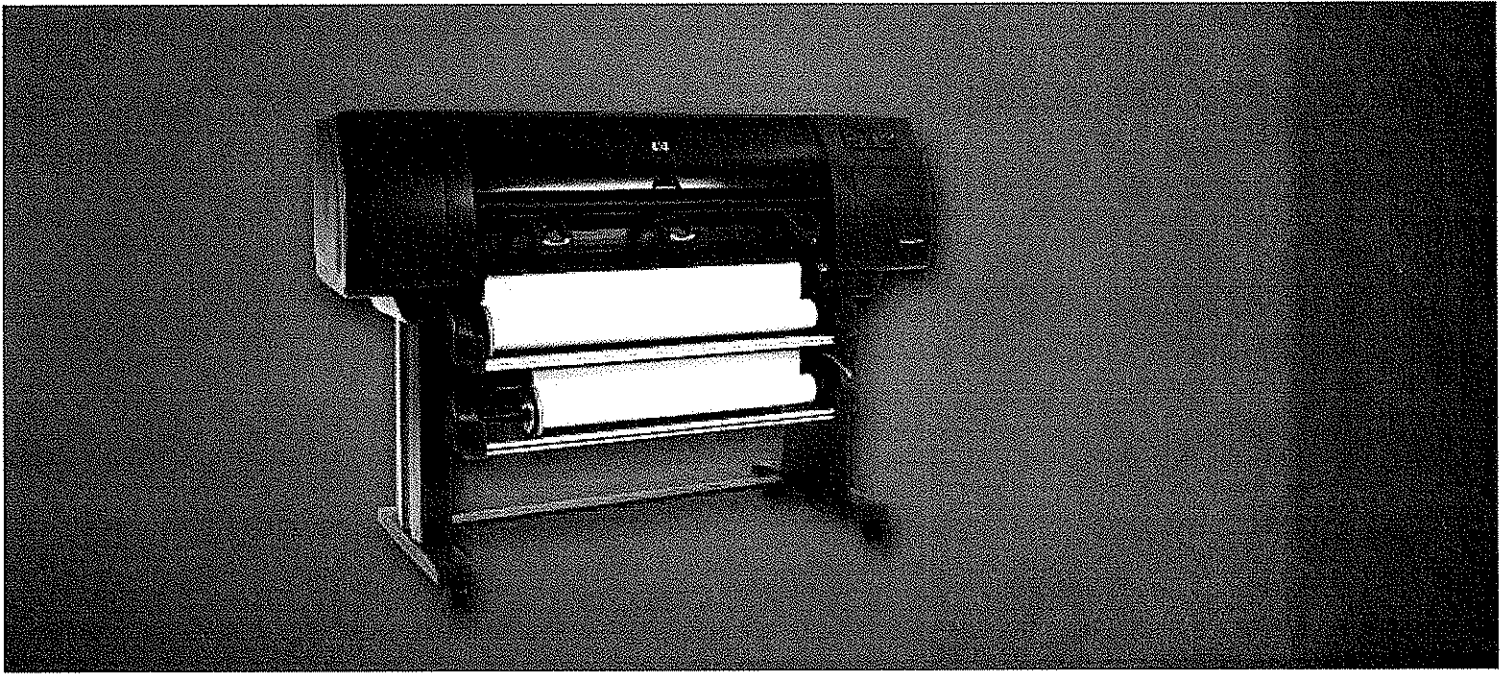

HP Designjet 4520 Printer series

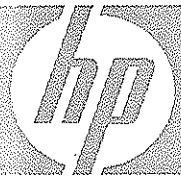

Ideal for color production and unattended printing

Unattended color production at low cost

- Take advantage of unattended color printing with two long media rolls up to 575 ft (175 meters) and reliable 775-ml black, 400-ml color Original HP ink cartridges.
- Double your print capacity and truly maximize productivity with HP Double Swath technology and 160 GB hard disk.
- Experience greater cost efficiency with free HP support, HP supplies that deliver a better value, and finishing options that save time and money.

Provides great possibilities to grow your business

- Experience more possibilities to increase your personal productivity with the HP Instant Printing Utility 2.0, HP Embedded Web Server, and the optional Serif PosterDesigner Pro for HP⁽¹⁾.
- Turn your HP Designjet into a print workflow management system with optional stacker and SCP reprocontrol for HP⁽²⁾.
- Produce excellent lines and images with patented HP inks, printheads enabling 0.1% line accuracy⁽³⁾, and HP Professional Color technologies.
- Expand your business with high performance copy and scan capabilities⁽⁴⁾.
- Choose from a broad portfolio of over 35 Original HP media for high-quality results from CAD drawings and renders to presentations and posters.

Trusted integration in your IT environment

- Trusted connectivity and security-with built-in Gigabit Ethernet networking, advanced access control and optional HP Jetdirect support for secure IPsec and IPv6⁽⁵⁾. A Linux PS driver offers additional support for Linux users⁽⁶⁾.
- Manage your HP Designjet, fleet of devices, and your costs with HP Web Jetadmin and the embedded Web server.
- Experience true peace of mind with a printer and printing supplies you know you can trust—from a company with years of experience and expertise.

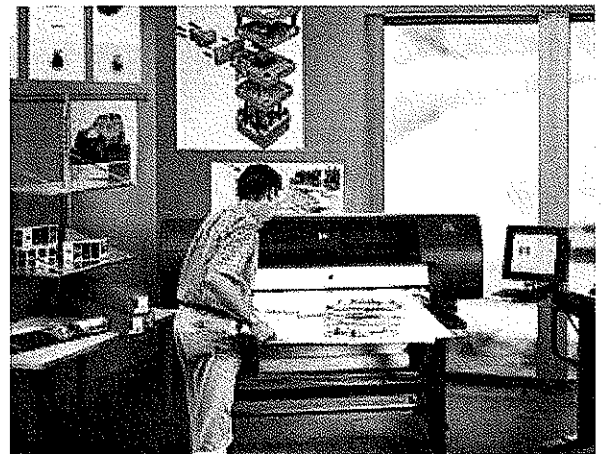

(1) Serif PosterDesigner Pro for HP is an optional feature. Not included, sold separately.
 (2) SCP reprocontrol for HP is an optional feature. Not included, sold separately.
 (3) +/-0.1% of the specified vector length or +/-0.1 mm (whichever greater) at 73° F (23° C), 50-60% relative humidity, on E/A0 printing material in Best or Normal mode with HP Matte Film.
 (4) The HP Designjet 4520 Scanner comes standard on the HP Designjet 4520 HD-MFP. It is an optional (not included, sold separately) accessory on the HP Designjet 4520 and 4520ps printers.
 (5) IPsec and IPv6 support requires the purchase of the HP Jetdirect 630n or HP Jetdirect 635n.
 (6) Available on the HP Designjet 4520ps Printer and HP Designjet 4520 HD-MFP only. Support in English only.

For High Production environment	100 B/A1 omis per hour	775-ml black, 400-ml color cartridges	160 GB hard disk	Optional PostScript	SCP reprocontrol for HP	2 rolls	Scanning/Copying capabilities
---------------------------------	------------------------	---------------------------------------	------------------	---------------------	-------------------------	---------	-------------------------------

HP Designjet 4520 Printer series

1. Ink cartridge of 225 and 400-ml for CMY, and 400 and 775-ml for K.
2. Accommodates 2 media rolls with long roll support up to 575 ft (175 m)
3. Front panel with user-friendly animations.
4. Color consistency and screen-to-print matching with HP Professional Color technologies.
5. Pairs of staggered printheads in the carriage mean the HP Designjet 4520 Printer series has double the print capacity of earlier models⁽⁷⁾.
6. HP Embedded Web Server for driverless file submission, queue management, preview, supplies and printer status, and error notification.
7. HP Embedded Jetdirect Gigabit Ethernet print server (1000Base-T) + 2 FireWire (IEEE-1394a compliant) ports.
8. EIO port for optional Jetdirect cards.
9. Embedded processor for simultaneous printing and processing. 160 GB hard disk and 608 MB standard memory—upgradeable to 1120 MB.
10. Equipped with a standard bin that holds 25 D (A1) prints. An optional stacker is capable of flattening and stacking up to 200 plots.

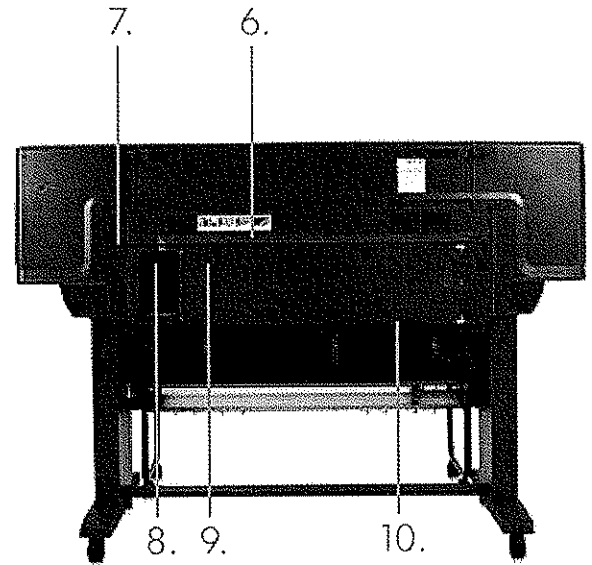
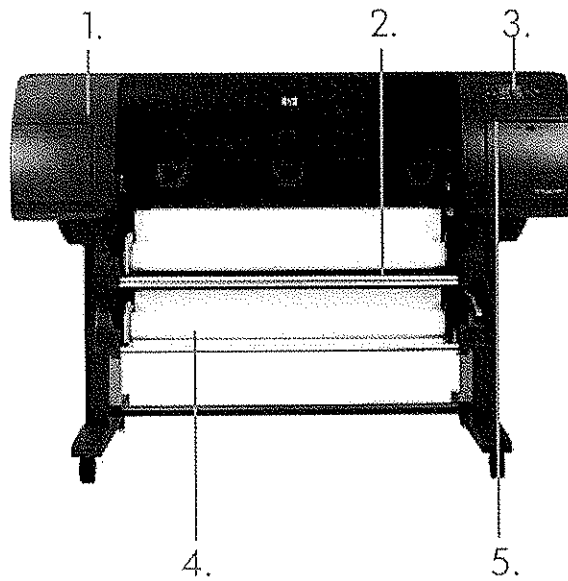

(7 Compared to any HP Designjet 600/700/800/1000 Printer

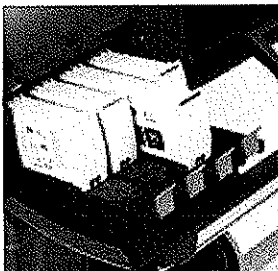

HP large black ink cartridge

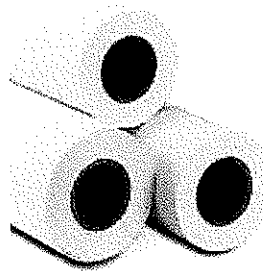

HP long media roll

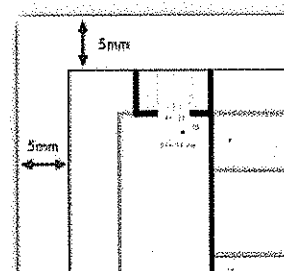

0.2 in (5 mm) margins

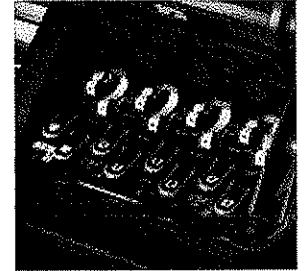

HP Double Swath Technology

HP Designjet 4520 Printer series at a glance

HP Designjet 4520 Printer

- Up to 42 in (1067 mm) wide
- 2400 x 1200 dpi maximum resolution
- Two media rolls with long roll support up to 575 ft (175 m)
- Ink supplies of 225 and 400-ml for CMY, 400 and 775-ml for K
- Embedded processor and 608 MB memory upgradeable up to 1120 MB, 160 GB hard disk
- Support for HP-GL/2, HP-RTL, TIFF, JPEG, CALS, G4

HP Designjet 4520ps Printer

- All the features of the 4520 model, plus
- Embedded RIP for Adobe PostScript 3, Adobe PDF 1.5

HP Designjet 4520 HD-MFP

- All the features of the 4520 model, plus
- Embedded RIP for Adobe PostScript 3, Adobe PDF 1.5
 - HP Designjet 4520 Scanner

Optional accessories

- HP Designjet 4500 Stacker
- HP Designjet 4520 Scanner⁴
- HP Designjet 42 in (1067 mm) Roll Feed Spindle
- HP Designjet 512-MB Memory Upgrade
- HP Designjet High-Speed USB 2.0 Card
- HP Jetdirect 630n IPv6 Gigabit Print Server
- HP Jetdirect 635n IPv6/IPsec Print Server
- Serif PosterDesigner Pro for HP
- SCP reprocontrol for HP

Optional service and support

- HP Installation Services with Network Setup (1-yr)
- HP Next Business Day Onsite Hardware Support, 3 years
- HP Same Day 9x5 Onsite Hardware Support, 3 years
- HP Same Day 18x5 Onsite Hardware Support, 3 years

Ideal for unattended printing of high-quality large-format drawings, graphics, maps, presentations, renders, and posters¹.

Full flexibility from the HP Designjet 4520 Printer series



More functionality with the HP Designjet 4520 HD-MFP

With scan speeds of 3 inches per second color and 10 inches per second black and white, 2 D (A1) size prints in less than 1 minute⁸, and excellent image quality (508 dpi optical resolution and up to 9600 dpi enhanced resolution), the HP Designjet 4520 HD-MFP delivers outstanding copy and scan performance. The integrated copy system of this Designjet features real-time print, media, and queue info in the scanner user interface, copy accounting in the printer, and copy job priority capability. Integration with the printer enables excellent copy quality and performance.

An easy-to-use touchscreen, easy color calibration, and easy print settings for printing sets make scanning and copying exceptionally user-friendly.

It is easy to integrate with a wide variety of industry-leading third-party applications such as scan, raster-to-vector conversion, or document management.

This MFP is fully compatible. Easily print scanned documents directly to almost any HP Designjet printer⁹. Built-in scan-to-network capabilities foster productivity with fewer steps. Easily save scanned files in PDF, TIFF, JPEG2000, and DWF file formats.

HP Designjet 4500 Stacker (optional)

The HP Designjet 4500 Stacker collects up to 200 D (A1) or E (A0) size plots and automatically flattens them, keeping them organized until you can gather them. Print unattended runs during business hours—and get more done—or overnight.

Free up production staff to work on multiple projects at once. The HP Designjet 4500 Stacker handles large black-and-white or color jobs without intervention. Unattended printing allows users to get more done.

Save time and collect your valuable, high-impact output as it prints with the HP Designjet 4500 Stacker. When you're ready to gather your output, it will be organized and waiting for you. Neatly and cleanly collects all sizes and weights of printable media supported by the HP Designjet 4520 Printer series¹⁰, including over 35 Original HP printing materials from new HP Cockle-free Coated Paper available in 100 g/m² and 170 g/m², to new chlorine-free HP Recycled Bond Paper made of 100% recycled base paper, to versatile HP Everyday Adhesive Matte Polypropylene and HP Durable Banner with DuPont™ Tyvek®.

(8) Mechanical printing time. One drawing printed in fast mode on HP Bright White Inkjet Paper (bond) speed indicated is maximum print speed.

(9) Fully compatible with HP Designjet 510, 4020, 4520, 5000, 5500, 7610, 11120, 72100, 73200, 76100 series products.

(10) Stacker performance may vary depending on the media used.

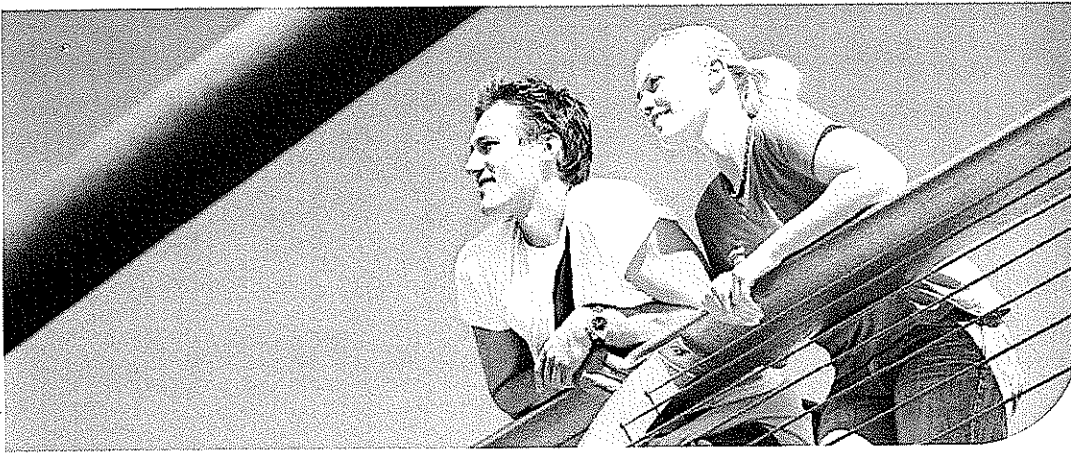

Océ
CS4300
scanner series

Capture and share
your vision

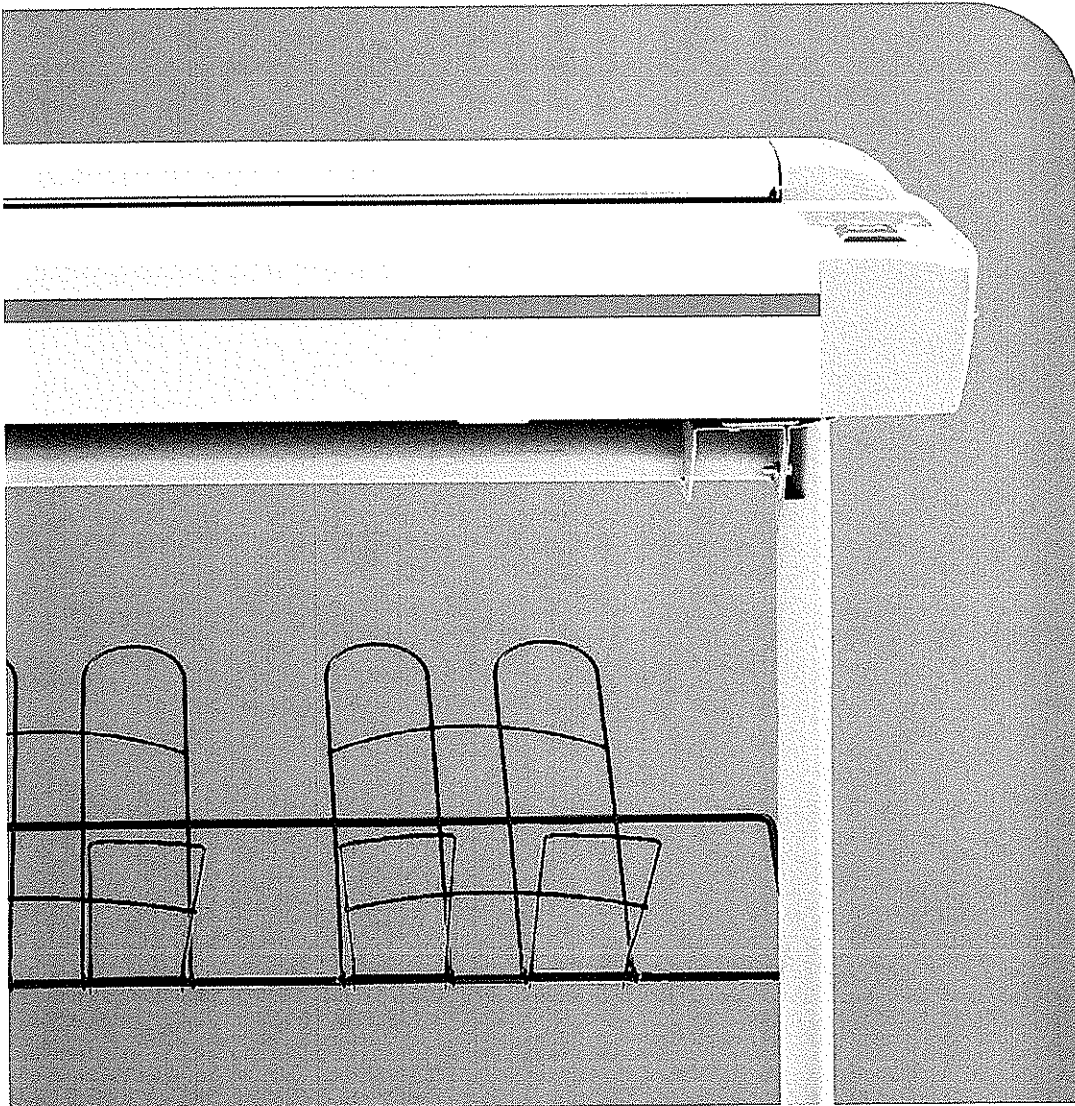

Advanced, versatile,
wide format color
scanners

Océ CS4300 scanner series

Advanced, versatile, wide format color scanners

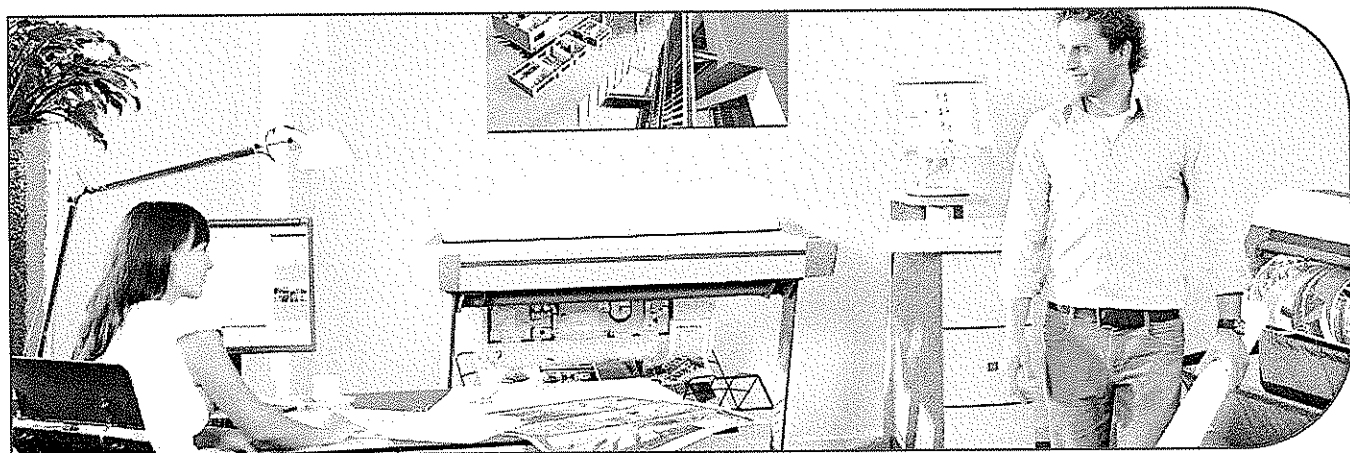

The Océ CS4300 scanner series is designed for professionals who want a high quality color scanner that can capture their ideas and share them with colleagues. Advanced technology makes these scanners versatile enough for a wide range of users and applications.

- When high quality counts
- Professional results the easy way
- Versatility and variety
- Sustainable and compliant

Advanced, versatile, wide format color scanners

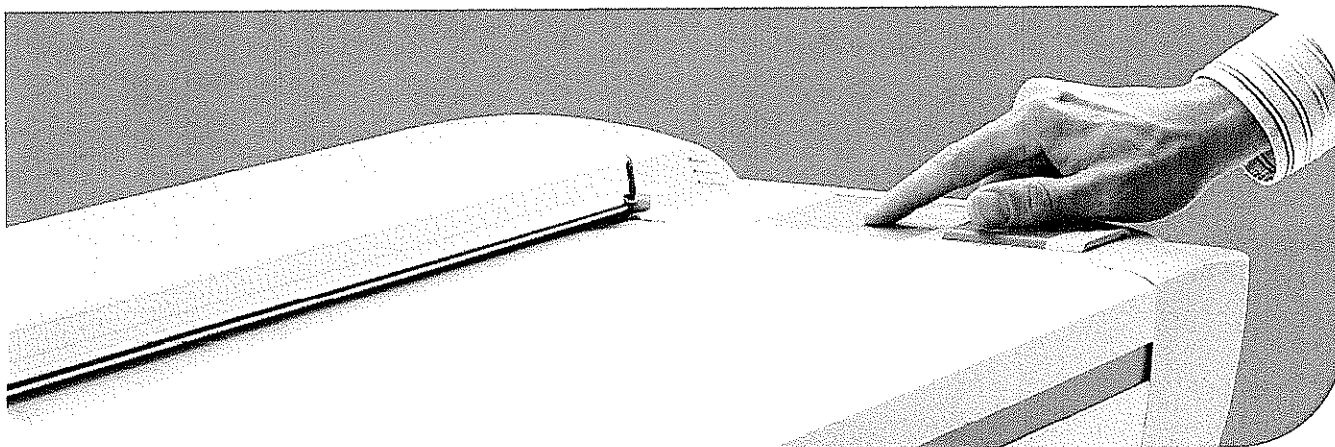

When high quality counts

The Océ CS4300 scanner series offers high quality scanning capability at an affordable price. 600 × 600 dpi resolution combined with advanced CCD technology delivers an optional interpolated resolution of up to 9600 dpi.

Professional results the easy way

It's easy to get professional results with the Océ CS4300 scanner series. The machines come with Océ Copy Easy software. This no-fuss software enables you to get scans right every time. It also upgrades your current Océ printer to a full hybrid system. Optional Océ Color Copy allows you to copy to multiple Océ wide format systems or third-party printers offering one single workflow for all your wide format hard copies.

You can scan and copy in full color or monochrome. And you can even scan rigid originals up to .5906 in. (15 mm) thick. With all of this the Océ CS4300 scanner series handles a broad range of applications: 2D and 3D CAD drawings, renderings, posters, photos, and much more.

Versatility and variety

The Océ CS4300 scanner series' versatility makes it ideal for a wide variety of users.

- Reprographers
- Medium-sized CAD studios and GIS environments
- Architects
- Small display graphics companies
- Central scan and copy environments

Sustainable and compliant

The Océ CS4300 scanner series is energy-efficient, going into sleep mode after a period of inactivity. It also features a standard timer clock that allows you to set power-up and power-down to meet the demands of your operations.

The Océ CS4300 scanner series is RoHS-compliant, meaning it contains no lead. Océ CS scanners are designed and manufactured to meet the ISO 14001 environmental management standard.

Technical specifications

	Océ CS4336 (Q)	Océ CS4336 (Q)S	Océ CS4342 (Q)S	Océ CS4354 (Q)S
36 inch model				
Speed * full color 8 bit color monochrome	3 ft./min. 7.4 ft./min. 59 ft./min.	7.4 ft./min. 15 ft./min. 59 ft./min.	7.4 ft./min. 15 ft./min. 59 ft./min.	7.4 ft./min. 15 ft./min. 59 ft./min.
Scan modes	Color, monochrome, and grayscale	Color, monochrome, and grayscale	Color, monochrome, and grayscale	Color, monochrome, and grayscale
Color space	sRGB	sRGB	sRGB	sRGB
Accuracy	0.1% ± 1 pixel	0.1% ± 1 pixel	0.1% ± 1 pixel	0.1% ± 1 pixel
Number of CCD cameras	3	3	4	4
Power consumption	180 W	180 W	180 W	180 W
Original width	44 inches	44 inches	44 inches	54 inches
Optical resolution	600 × 600 dpi	600 × 600 dpi	600 × 600 dpi	508 × 508 dpi
Interpolated resolution (Q upgrade card)	1200 dpi (9600 dpi)	1200 dpi (9600 dpi)	1200 dpi (9600 dpi)	1200 dpi (9600 dpi)
Technology	CCD (Charge coupled device)	CCD (Charge coupled device)	CCD (Charge coupled device)	CCD (Charge coupled device)
Original handling	Face down	Face down	Face down	Face down
Original release	Front and back	Front and back	Front and back	Front and back
Stand	Included	Included	Included	Included
Supported Operating systems	Windows XP®, Server 2003®, and Windows Vista® 32 bits	Windows XP, Server 2003, and Windows Vista 32 bits	Windows XP, Server 2003, and Windows Vista 32 bits	Windows XP, Server 2003, and Windows Vista 32 bits
Standard interface	Double speed USB2 with xDTR, STI (Still Image Interface), WIA (Windows® Image Acquisition), TWAIN	Double speed USB2 with xDTR, STI (Still Image Interface), WIA (Windows Image Acquisition), TWAIN	Double speed USB2 with xDTR, STI (Still Image Interface), WIA (Windows Image Acquisition), TWAIN	Double speed USB2 with xDTR, STI (Still Image Interface), WIA (Windows Image Acquisition), TWAIN
Standard accessory	Océ CS43xx scanner Océ CS43xx scanner stand Original receiving basket Océ Copy Easy software USB2 cable Power Cable Maintenance kit, CD includes: Océ Copy Easy software Océ Color Copy demo Scanner Agent Scanner maintenance Quick reference guide User documentation	Océ CS43xx scanner Océ CS43xx scanner stand Original receiving basket Océ Copy Easy software USB2 cable Power Cable Maintenance kit, CD includes: Océ Copy Easy software Océ Color Copy demo Scanner Agent Scanner maintenance Quick reference guide User documentation	Océ CS43xx scanner Océ CS43xx scanner stand Original receiving basket Océ Copy Easy software USB2 cable Power Cable Maintenance kit, CD includes: Océ Copy Easy software Océ Color Copy demo Scanner Agent Scanner maintenance Quick reference guide User documentation	Océ CS43xx scanner Océ CS43xx scanner stand Original receiving basket Océ Copy Easy software USB2 cable Power Cable Maintenance kit, CD includes: Océ Copy Easy software Océ Color Copy demo Scanner Agent Scanner maintenance Quick reference guide User documentation
Installation	User installable, installation guides, CDs and tools included	User installable, installation guides, CDs and tools included	User installable, installation guides, CDs and tools included	User installable, installation guides, CDs and tools included
Warm-up time	Ca 10 minutes depending on the environment temperature	Ca 10 minutes depending on the environment temperature	Ca 10 minutes depending on the environment temperature	Ca 10 minutes depending on the environment temperature
Boot up time	7 sec.	7 sec.	7 sec.	7 sec.
Weight excluding stand	134 lbs., 61 kg	134 lbs., 61 kg	134 lbs., 61 kg	1274 lbs., 79 kg
Dimensions excluding stand	55" W × 19" D × 7" H 139 W × 46 D × 18 H cm	55" W × 19" D × 7" H 139 W × 46 D × 18 H cm	55" W × 19" D × 7" H 139 W × 46 D × 18 H cm	67" W × 19" D × 7" H 169 W × 46 D × 18 H cm
Power requirements	110V/220V/240V 50/50 Hz 180 W	110V/220V/240V 50/50 Hz 180 W	110V/220V/240V 50/50 Hz 180 W	110V/220V/240V 50/50 Hz 180 W
Awards	ISO 14001, 2004 Environmental RoHs compliancy Management system	ISO 14001, 2004 Environmental RoHs compliancy Management system	ISO 14001, 2004 Environmental RoHs compliancy Management system	ISO 14001, 2004 Environmental RoHs compliancy Management system
Produced	European Union	European Union	European Union	European Union
Options	Océ Color Copy Original Receiving Rack	Océ Color Copy Original Receiving Rack	Océ Color Copy Original Receiving Rack	Océ Color Copy Original Receiving Rack



CHARLESTON BLUEPRINT, INC.
 1203 VIRGINIA STREET EAST 4000 STATE ROUTE 34
 CHARLESTON, WV 25301 HURRICANE, WV 25526
 (304) 343-1063 (304) 760-0166
 (800) 220-9625 (304) 760-0168 FAX

*400 dpi turbo mode

Océ Copy Easy color and monochrome copying and scan to file software

Copy features

- Direct ready for copying
- Automatic scanner detection
- No closed loop calibration required
- Scanners, media, and printer precalibrated
- Color and monochrome output, copy, and scan to file

Green button color copying

- Automatic printer media type detection
- Automatic printer media width detection
- Standard copy profiles for Océ media
- Standard image enhancement for 5 original types

Original size detection

- Automatic or manual

Instant copying

- Printing while scanning (set original size manually)

Preview

- Preview original
- Preview effect of original enhancement
- Preview position on roll media
- Zoom in/out

Copy area of interest

- Select copy area with mouse

Simple nesting

- Nest multiple copies of same scan

Deskew original

- Automatic deskew original

Original rewind

- Configurable

Scanning features

- Green button color and monochrome scanning
- Standard image enhancement for five original types
- Automatic file name increment

Supported file formats

- BMP, EPS, GIF, HPR, HP-RTL, IFF, JPEG, J2K JPEG2000, PCX, PDF, PDF/A, PNG, PPM, TGA, TIFF, 6RN

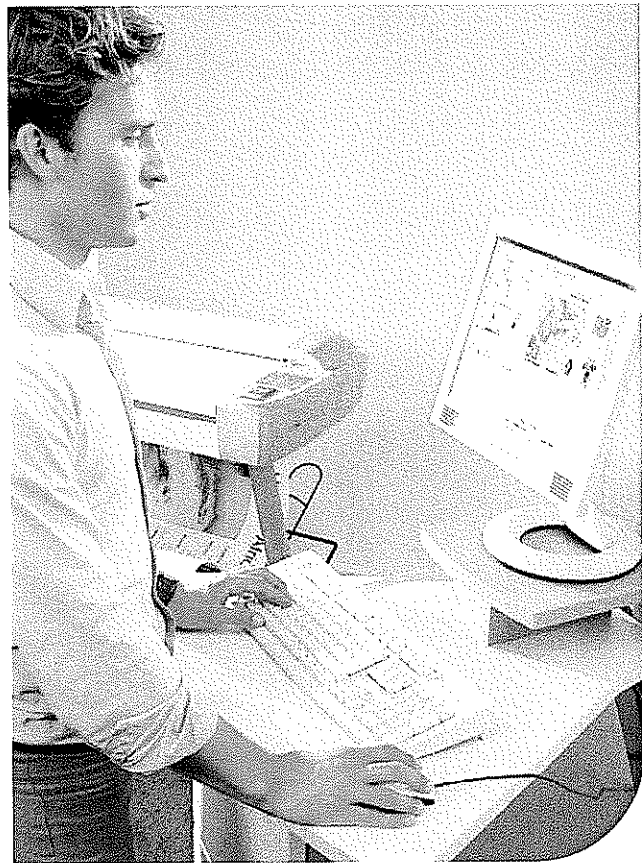

General

Operating systems

- Windows 2000®, Windows XP, Vista 32-bit

Minimum platform

- Intel® Pentium® IV 2.66 GHz/Atlon, 60 GB hard drive, 1 GB RAM, Network board 100BaseT

Protection

- Connection to CS4100, CS4200 or CS4300 scanner is required

Zooming

- 1–1000%

Supported printers

- Océ TDS300 printer
- Océ TDS320 printer
- Océ TDS400 printer
- Océ TDS450 printer
- Océ TCS300 printer
- Océ TCS400 printer
- Océ TCS500 printer
- Océ CS20xx series printer
- Océ CS21xx series printer
- Océ CS22xx series printer
- Océ ColorWave™ 600 printer

Beyond the Ordinary

Environmental Certifications



Mixed Sources

Product group from well-managed forests and other controlled sources
www.fsc.org Cert no. SCS-COC-00856
© 1996 Forest Stewardship Council



Awards



communication design award

2006



product design award

2007



product design award

2008



product design award

2008



Partners Certifications



© 2008 Océ. Illustrations and specifications do not necessarily apply to products and services offered in each local market. Technical specifications are subject to change without prior notice. The Océ logo and "Océ" are registered trademarks of Océ-Technologies B.V. "ColorWave" is a trademark of Océ-Technologies B.V. "Windows", "Windows XP", "Server 2003", "Windows 2000", and "Windows Vista" are registered trademarks of Microsoft Corporation. "Intel" and "Pentium" are registered trademarks of Intel Corporation. All other trademarks are the property of their respective owners.



Printing for Professionals

Océ helps the people who make our world. Companies everywhere use Océ high-speed printing, technical documentation, and professional document systems to keep the wheels of business, industry and government turning. Océ also helps the world. Developing products and services that add value to the document processes of our customers, while minimizing environmental impact and protecting health and safety, has always been one of our core principles. From bank statements to utility bills, from blueprints to newspapers, from on-demand documents to wide-format display graphics, Océ helps our professional customers go "Beyond the Ordinary" in print and document management.

Océ North America

Océ Wide Format Printing Systems
5450 North Cumberland Avenue
Chicago, Illinois 60656
1-800-714-4427
1-773-714-4076
Fax 1-773-714-4056
email: us.info@oce.com

Océ-Canada, Inc.
4711 Yonge Street, Suite 1100
Toronto, Ontario, M2N 6K8
Canada
1-800-668-1945
Fax 1-416-224-5778
email: info.ca@oce.com

Océ Mexico, S.A. de C.V.
Ave. Pol. Paseo de la
Reforma No. 1236 Piso 4
Mexico City, DF 05348
52-55-5089-8700
email: mex.info@oce.com

For information and services, visit us at:
www.oceusa.com



Océ and Sustainability



Green Business is Good Business

Do you know the difference between “sustainable” and “green”? Green behavior or products are actually a subset of sustainability. Green relates to decreasing the impact on the environment. Sustainability centers on the notion that we minimize environmental impact and support a sustainable future. According to the World Commission on Environment and Development (the Brundtland Commission), sustainability is defined as *“development that meets the needs of the present without compromising the ability of future generations to meet their needs.”*

Sustainability by nature is about the future. It is about business practices that balance the interest of the planet, people and profitability. Customers are challenging manufacturers to find better ways to protect and preserve resources. Environmentally conscious companies are initiating efforts to balance what is good for business with what is good for the planet. For many companies, sustainability has just recently become part of their corporate missions. For Océ, sustainability has been a defining philosophy and part of its DNA for years. From the founding of the company in 1877, when Océ invented butter-coloring agents made from vegetable raw materials rather than chemicals, to its invention of an ammonia-free diazo process in 1927, and a new production process for coating paper that reduced the use of solvents by 80 percent in 1958, through to the present day, Océ has continued to expand its sustainability focus.

Océ has taken the interests of people, the planet and profitability into account to add value in three ways:

- Océ develops sustainable products
- Océ produces printers and scanners in a sustainable way
- Océ products and services enable Océ customers to operate in a sustainable manner

Océ develops sustainable products

Océ builds its products for a prolonged life. Building products primarily made from metal and steel allows the maximum reuse of parts and minimizes landfill. Océ was one of the first companies in the industry to be RoHS compliant. The Restriction of Hazardous Substances Directive (RoHS), which became effective in Europe in July 2006 and in California in January 2007, is part of a legislative initiative to solve the problem of large amounts of toxic electronics-related waste. RoHS places limits on the use of six hazardous materials in new electrical and electronic equipment. This is just one example of where Océ has made an investment across the entire product line to eliminate toxic waste. By continually raising the level of reliability of its products, extending the lifecycle of parts and consumables, incorporating powerful IT tools to monitor machines remotely and designing hardware and software on the basis of open



Océ and Sustainability



architecture, Océ systems greatly reduce the necessity of a product entering the waste stream prematurely.

Océ produces printers and scanners in a sustainable way

Reuse and remanufacturing play an important role in Océ's overall manufacturing process. The important factors being controlled are the materials used and the amount of resources used in the manufacturing process. Océ focuses on the maximum reuse of parts and reports on the environmental impact of manufacturing operations as it pertains to ozone depleting substances, water, energy, waste, and emissions to the air. Improvement targets for all main production areas are set yearly and reported on in the Océ Sustainability Report. (For the 2006 report, which was audited by PricewaterhouseCoopers and GRI rated, visit www.oce.com/en/about/HSE/sustain2006.)

Océ products and services enable Océ customers to operate in a sustainable manner

Making the choice to use Océ products can make a difference to the environment and your profitability. Océ systems have lower energy consumption, have lower ozone emission, use less heat and noise, reduce paper waste and are able to use recycled paper. And the savings are measurable. For example, Océ radiant fusing technology - as used in the Océ TDS320, Océ TDS450, and Océ TDS700 - can save approximately 320 kW/month in typical low-to-mid volume environments. This is equivalent to not driving .6 passenger cars for one year, saving 297 gallons of gasoline, or enabling a household to shut off its electricity for three months! And the environmental savings translate to pollution reductions of 5,750 lbs. of greenhouse gases (CO₂), 8 lbs. of nitrogen oxides, 2.6 metric tons of carbon monoxide, and 20 lbs. of sulfur dioxide in one year. (Source: Cleaner & Greener web site www.cleanerandgreener.org & U.S. Climate Technology Cooperation web site www.usctcgateway.net.)

Océ will continue to implement sustainability policies that balance what's good for business with what's good for the environment. And as the preference in business relationships shifts to companies that are green, it will become increasingly more important to be seen as taking the lead as an environmental steward and agent of change. For more information on Océ and Sustainability, please contact Océ at us.info@oce.com.



Océ and Sustainability



Green Business is Good Business

Do you know the difference between “sustainable” and “green”? Green behavior or products are actually a subset of sustainability. Green relates to decreasing the impact on the environment. Sustainability centers on the notion that we minimize environmental impact and support a sustainable future. According to the World Commission on Environment and Development (the Brundtland Commission), sustainability is defined as “*development that meets the needs of the present without compromising the ability of future generations to meet their needs.*”

Sustainability by nature is about the future. It is about business practices that balance the interest of the planet, people and profitability. Customers are challenging manufacturers to find better ways to protect and preserve resources. Environmentally conscious companies are initiating efforts to balance what is good for business with what is good for the planet. For many companies, sustainability has just recently become part of their corporate missions. For Océ, sustainability has been a defining philosophy and part of its DNA for years. From the founding of the company in 1877, when Océ invented butter-coloring agents made from vegetable raw materials rather than chemicals, to its invention of an ammonia-free diazo process in 1927, and a new production process for coating paper that reduced the use of solvents by 80 percent in 1958, through to the present day, Océ has continued to expand its sustainability focus.

Océ has taken the interests of people, the planet and profitability into account to add value in three ways:

- Océ develops sustainable products
- Océ produces printers and scanners in a sustainable way
- Océ products and services enable Océ customers to operate in a sustainable manner

Océ develops sustainable products

Océ builds its products for a prolonged life. Building products primarily made from metal and steel allows the maximum reuse of parts and minimizes landfill. Océ was one of the first companies in the industry to be RoHS compliant. The Restriction of Hazardous Substances Directive (RoHS), which became effective in Europe in July 2006 and in California in January 2007, is part of a legislative initiative to solve the problem of large amounts of toxic electronics-related waste. RoHS places limits on the use of six hazardous materials in new electrical and electronic equipment. This is just one example of where Océ has made an investment across the entire product line to eliminate toxic waste. By continually raising the level of reliability of its products, extending the lifecycle of parts and consumables, incorporating powerful IT tools to monitor machines remotely and designing hardware and software on the basis of open



Océ and Sustainability



architecture, Océ systems greatly reduce the necessity of a product entering the waste stream prematurely.

Océ produces printers and scanners in a sustainable way

Reuse and remanufacturing play an important role in Océ's overall manufacturing process. The important factors being controlled are the materials used and the amount of resources used in the manufacturing process. Océ focuses on the maximum reuse of parts and reports on the environmental impact of manufacturing operations as it pertains to ozone depleting substances, water, energy, waste, and emissions to the air. Improvement targets for all main production areas are set yearly and reported on in the Océ Sustainability Report. (For the 2006 report, which was audited by PricewaterhouseCoopers and GRI rated, visit www.oce.com/en/about/HSE/sustain2006.)

Océ products and services enable Océ customers to operate in a sustainable manner

Making the choice to use Océ products can make a difference to the environment and your profitability. Océ systems have lower energy consumption, have lower ozone emission, use less heat and noise, reduce paper waste and are able to use recycled paper. And the savings are measurable. For example, Océ radiant fusing technology - as used in the Océ TDS320, Océ TDS450, and Océ TDS700 - can save approximately 320 kW/month in typical low-to-mid volume environments. This is equivalent to not driving .6 passenger cars for one year, saving 297 gallons of gasoline, or enabling a household to shut off its electricity for three months! And the environmental savings translate to pollution reductions of 5,750 lbs. of greenhouse gases (CO₂), 8 lbs. of nitrogen oxides, 2.6 metric tons of carbon monoxide, and 20 lbs. of sulfur dioxide in one year. (Source: Cleaner & Greener web site www.cleanerandgreener.org & U.S. Climate Technology Cooperation web site www.usctcgateway.net.)

Océ will continue to implement sustainability policies that balance what's good for business with what's good for the environment. And as the preference in business relationships shifts to companies that are green, it will become increasingly more important to be seen as taking the lead as an environmental steward and agent of change. For more information on Océ and Sustainability, please contact Océ at us.info@oce.com.



Improving Your Business



Energy Efficient Systems

Lower power consumption saves money and the environment

Océ develops products and services that add value to the document processes of our customers. The Océ TDS line is Energy Star compliant; this ensures you protect not only your company's profits, but the environment as well.

What is the Energy Star® Program?

The Energy Star program sponsored by the U.S. Environmental Protection Administration promotes the manufacturing and marketing of energy-efficient equipment. The Energy Star means that the equipment purchased makes use of specific power management techniques to prevent unnecessary power consumption and offer economical and environmental benefits.

The Océ TDS product line and Energy Star.

The Océ TDS320, Océ TDS450, Océ TDS600, Océ TDS700 and Océ TDS800 Pro have received the Energy Star designation. This means that they have all met the EPA guidelines for the manufacture of energy efficient equipment. Océ offers products that can be used safely. Océ also sets strict standards regarding substance emissions and noise levels. Some of the ecological improvements include:

- The use of polypropylene toner bottles
- Océ's "upgrade before replacement policy"
- Océ has eliminated the use of hazardous materials and ozone depleting substances

Energy Star and the Océ TDS 320, Océ TDS450, Océ TDS600 and Océ TDS700.

Many Océ TDS320, Océ TDS450 and Océ TDS600 machines are used in low to mid-volume workgroup environments. They use about 1500 watts of electricity while printing. Thanks to Océ's Radiant Fusing technology however, the electricity used in standby (between print jobs) is only about 42 watts. That is why these machines have received the Energy Star designation.

An added advantage of the Océ TDS systems is that your workgroup environment stays cooler because of the low heat output of the machine. This can save money on your cooling costs.

Competitive products in this volume range generally use 690 watts to 1000 watts of electricity while in standby. This can cost a business a great deal of money in the course of a year.

Energy Star and the Océ TDS800 Pro

The Océ TS800 Pro is a high volume wide format machine generally used in central reprographic environments. Many of the Océ TDS800 Pro machines are running 8 – 10 hours a day or longer. The Océ Copy Press system is designed for this type of heavy demand use.

The Océ TDS800 Pro uses about 4100 watts of electricity because of its high volume, high demand nature when it is printing. But for those times when the machine is not printing, the power consumption drops to 820 watts in the machines low power mode, and drops even further to 495 watts in the machines sleep mode.

Competitive high volume systems generally use between 1800 watts to 5000 watts while in the standby mode, a waste of electricity at a significant cost to a business.

Why choose Océ?

Océ products are essentially in virtually every working environment, it is important that they operate as cleanly and quietly as possible for your employees. Océ offers your business an energy efficient solution that helps save you money while protecting the environment





Improving Your Business



Océ Radiant Fusing

Helping workgroup environments become green environments with reliability and energy efficiency.

Océ Radiant Fusing technology is ideal in environments, where users appreciate reliability, energy efficiency, low heat and noise output, instant on capabilities, very high image quality, and low ozone emissions. It helps your office remain productive and environmentally friendly.

What Makes Océ Radiant Fusing Different From Other Technologies?

During the Océ Radiant Fusing process, toner is fused to the media by heat rising from a grid of heating elements. The toner melts and is fused to the media without distorting the image. Competitive wide format printers use hot pressure rollers to fuse the image to the media. They require a lubricant on the fuser rollers to prevent the print from sticking to the roller. This lubricant is usually silicone oil, which can leave a residue on the print.

Benefits of Océ Radiant Fusing Include Superior Image Quality

With Océ Radiant Fusing Technology, the media traveling through the fuser never makes contact with pressure rollers. Pressure rollers tend to smash the toner into the media, which can blur the printed image. Océ Radiant Fusing prevents resolution loss, dot size degradation

and line fuzziness as the toner is fused exactly as it is placed on the media.

Océ Radiant Fusing Products Operate at Lower Temperatures

Because there are no pressure rollers to heat, Océ Radiant fusing products maintain a lower operating temperature. The fusing section heats quickly to fuse the toner to the media, and cools quickly when the task is complete. Once the print job is completed, Océ Radiant Fusing printers go into a 'sleep mode' and draw minimum power. That is why all Océ Radiant Fusing printers have earned the U.S. Department of Energy, Energy Star® designation. When compared to competitors products, Océ Radiant Fusing consumes significantly less electricity. Over the course of a year the savings in electricity costs can add up.

Helps Create a "Green" Office Environment

Océ Radiant Fusing technology helps minimize the impact on the environment with low ozone emissions and by not producing toxic waste. You get superior print quality while caring for the environment.

Perfect for Workgroups

Océ Radiant Fusing products generate less heat and noise so they easily fit into a workgroup environment. Also, the instant-on capability means no waiting for the machine to warm up before getting prints.

Greater Long Term Reliability

Océ Radiant Fusing products have fewer consumable parts, (no fuser oil or fusing rollers), and generate less internal heat. This means fewer parts to service and replace. Lower overall heat extends the life of machine components and eliminates excess waste.





Green Business is Good Business



Océ Sustainability Analysis

Sustainability Claim	Background Information	Océ
ENERGY STAR Qualification	In 2007 the U.S. EPA made the ENERGY STAR criteria more stringent. The Océ TDS, TCS, and Océ ColorWave printers all meet the more stringent 2007 ENERGY STAR criteria. This list can be found at: http://www.energystar.gov/index.cfm?fuseaction=find_a_product.ShowProductGroup&pgw_code=PS	Yes
RoHS Compliancy	Océ was one of the first companies to reach full RoHS compliancy for our entire product line up. The Restriction of Hazardous Substances Directive became effective in Europe in July 2006 and in California in January 2007. RoHS is aimed at protecting both human health and the environment by placing limits on the use of hazardous materials in new electrical and electronic equipment. In order to sell electric/electronic equipment in Europe all companies must be RoHS compliant.	Yes
ISO 14001 Certified	Océ has been certified since 1997.	Yes
Limited Ozone Emissions	Océ products are 1000% lower than legal standards and about one-tenth the ozone emissions of conventional printing technologies. Ozone emissions from printing equipment have been associated with headaches, coughing, fatigue and this can lead to loss in productivity.	Yes
Manufactures a line of Eco Design Printers	Radiant Fusing technology used in all Océ Eco Design printers require no warm-up time and instantly returns to sleep mode after printing.	Yes
Organic Photoreceptors	Océ is able to reuse or recycle at least 95% of its wide format printing systems at the end of their life. This is after they go through remanufacturing and asset recovery.	Yes
Recyclable Toner Containers	Océ will soon be shipping toner bottles clearly marked with environmental recommendations on how to handle disposal of the Océ bottles. In some cases, recycling may not be the best thing for the environment (transportation, cleaning with water & chemicals and energy used). If waste is burned locally, this may be the preferred method. Please refer to you local resources. www.nrc-recycling.org/localresources.aspx or www.earth911.org	Yes
Recyclable Photoreceptors	Océ has a process and program in place for recovering and recycling in the most environmentally safe way.	Yes
Prints on Recycled Paper	Océ's warranty and maintenance will support printing on 30% post consumer waste recycled media 100% of the time.	Yes
Automatic Image Rotation & Media Selection Ensure Minimal Paper Waste	Océ has multiple roll options, some up to six rolls allowing our users to get prints without extra waste. By having a cutter per drawer, Océ is also able to help maximize productivity and up-time. Océ Client Tools is free print submission software and when coupled with Océ Repro Desk Server, it allows users to: reduce waste by eliminating mistakes with WYSIWYP previewing, reduce fuel consumption of delivery vehicles with electronic document submission or distribution, decreases consumer packaging waste with digital	Yes

	product delivery, reduce paper and toner consumption by eliminating the need for checkplots, and saves paper by easily creating smaller trade sets of plans and specs to list a few of the environmental advantages.	
History of Sustainability	For 130 Years Océ has been an innovator in Sustainable behavior. From 1877 when Océ invented a butter-coloring agent made from vegetable materials, 1927 Océ invents the ammonia-free diazo copying process, 1990 Océ opens its first equipment recovery plant to 1995 launching the first Eco-copier and so on...	Yes
Issues a Sustainability Report	Since 2002 Océ has provided a Sustainability Report, audited by a third party and recognized by Global Reporting Initiative (GRI), to present measurable activities as they pertain to environmental performance data such as materials used in manufacturing, energy and water, waste and emissions, compliance and environmental incidents as well as results and targets for the following years to come.	Yes
Leasing Options for the Environment	Océ offers leasing programs allowing customers to responsibly return Océ equipment for remanufacturing and asset recovery.	Yes
Recipient of Environmental Awards	In 1975 Océ received Europe's first award in research in environmental protection. In 2006 Océ was the recipient of FedEx Kinko's™ Best in Sustainability/Environmental Performance award.	Yes
Promotes Customer Sustainability	Océ encourages and rewards customers for their efforts towards a more sustainable future. Océ awarded the "Green Reprographer of the Year" award in 2008 recognizing forward thinking within the reprographics community.	Yes