



**State of West Virginia
Department of Administration
Purchasing Division**

NOTICE

Due to the size of this bid, it was impractical to scan every page for online viewing. We have made an attempt to scan and publish all pertinent bid information. However, it is important to note that some pages were necessarily omitted.

If you would like to review the bid in its entirety, please contact the buyer. Thank you.



State of West Virginia
 Department of Administration
 Purchasing Division
 2019 Washington Street East
 Post Office Box 50130
 Charleston, WV 25305-0130

Request for Quotation

RFQ NUMBER
 WEH90053

PAGE
 1

ADDRESS CORRESPONDENCE TO ATTENTION OF:
 ROBERTA WAGNER
 304-558-0067

HEALTH AND HUMAN RESOURCES
 WELCH COMMUNITY HOSPITAL
 454 MCDOWELL STREET
 WELCH, WV 24801 304-436-8710

*709070313 02 304-757-7457
 SIEMENS HEALTHCARE DIAGNOSTICS
 211 BEECHWOOD ESTATES
 SCOTT DEPOT WV 25560

SHIP TO

PROFIT

DATE PRINTED	TERMS OF SALE	SHIP VIA	F.O.B.	FREIGHT TERMS
02/12/2009				

BID OPENING DATE: 02/26/2009 BID OPENING TIME 01:30PM

LINE	QUANTITY	UOP	CAT NO.	ITEM NUMBER	UNIT PRICE	AMOUNT
ADDENDUM NO. 1 1. QUESTIONS AND ANSWERS ARE ATTACHED. 2. ADDENDUM ACKNOWLEDGEMENT IS ATTACHED. THIS DOCUMENT SHOULD BE SIGNED AND RETURNED WITH YOUR BID. FAILURE TO SIGN AND RETURN MAY RESULT IN DISQUALIFICATION OF YOUR BID. EXHIBIT 10 REQUISITION NO.: WEH90053 ADDENDUM ACKNOWLEDGEMENT I HEREBY ACKNOWLEDGE RECEIPT OF THE FOLLOWING CHECKED ADDENDUM(S) AND HAVE MADE THE NECESSARY REVISIONS TO MY PROPOSAL, PLANS AND/OR SPECIFICATION, ETC. ADDENDUM NO.'S: NO. 1 ✓ NO. 2 NO. 3 NO. 4 NO. 5 I UNDERSTAND THAT FAILURE TO CONFIRM THE RECEIPT OF THE ADDENDUM(S) MAY BE CAUSE FOR REJECTION OF BIDS.						

SEE REVERSE SIDE FOR TERMS AND CONDITIONS

SIGNATURE <i>William K. Strevie</i>	TELEPHONE 847-236-7280	DATE 2/20/09
TITLE VP, SALES/CUSTOMER OPS	FEIN 95-2802182	ADDRESS CHANGES TO BE NOTED ABOVE

WHEN RESPONDING TO RFQ, INSERT NAME AND ADDRESS IN SPACE ABOVE LABELED 'VENDOR'

**GENERAL TERMS & CONDITIONS
REQUEST FOR QUOTATION (RFQ) AND REQUEST FOR PROPOSAL (RFP)**

1. Awards will be made in the best interest of the State of West Virginia.
2. The State may accept or reject in part, or in whole, any bid.
3. All quotations are governed by the *West Virginia Code* and the *Legislative Rules* of the Purchasing Division.
4. Prior to any award, the apparent successful vendor must be properly registered with the Purchasing Division and have paid the required \$125 fee.
5. All services performed or goods delivered under State Purchase Order/Contracts are to be continued for the term of the Purchase Order/Contracts, contingent upon funds being appropriated by the Legislature or otherwise being made available. In the event funds are not appropriated or otherwise available for these services or goods, this Purchase Order/Contract becomes void and of no effect after June 30.
6. Payment may only be made after the delivery and acceptance of goods or services.
7. Interest may be paid for late payment in accordance with the *West Virginia Code*.
8. Vendor preference will be granted upon written request in accordance with the *West Virginia Code*.
9. The State of West Virginia is exempt from federal and state taxes and will not pay or reimburse such taxes.
10. The Director of Purchasing may cancel any Purchase Order/Contract upon 30 days written notice to the seller.
11. The laws of the State of West Virginia and the *Legislative Rules* of the Purchasing Division shall govern all rights and duties under the Contract, including without limitation the validity of this Purchase Order/Contract.
12. Any reference to automatic renewal is hereby deleted. The Contract may be renewed only upon mutual written agreement of the parties.
13. **BANKRUPTCY:** In the event the vendor/contractor files for bankruptcy protection, this Contract may be deemed null and void, and terminated without further order.
14. **HIPAA BUSINESS ASSOCIATE ADDENDUM:** The West Virginia State Government HIPAA Business Associate Addendum (BAA), approved by the Attorney General, and available online at the Purchasing Division's web site (<http://www.state.wv.us/admin/purchase/vrc/hipaa.htm>) is hereby made part of the agreement. Provided that, the Agency meets the definition of a Cover Entity (45 CFR §160.103) and will be disclosing Protected Health Information (45 CFR §160.103) to the vendor.
15. **WEST VIRGINIA ALCOHOL & DRUG-FREE WORKPLACE ACT:** If this Contract constitutes a public improvement construction contract as set forth in Article 1D, Chapter 21 of the West Virginia Code ("The West Virginia Alcohol and Drug-Free Workplace Act"), then the following language shall hereby become part of this Contract: "The contractor and its subcontractors shall implement and maintain a written drug-free workplace policy in compliance with the West Virginia Alcohol and Drug-Free Workplace Act, as set forth in Article 1D, Chapter 21 of the West Virginia Code. The contractor and its subcontractors shall provide a sworn statement in writing, under the penalties of perjury, that they maintain a valid drug-free work place policy in compliance with the West Virginia and Drug-Free Workplace Act. It is understood and agreed that this Contract shall be cancelled by the awarding authority if the Contractor: 1) Fails to implement its drug-free workplace policy; 2) Fails to provide information regarding implementation of the contractor's drug-free workplace policy at the request of the public authority; or 3) Provides to the public authority false information regarding the contractor's drug-free workplace policy."

INSTRUCTIONS TO BIDDERS

1. Use the quotation forms provided by the Purchasing Division.
2. **SPECIFICATIONS:** Items offered must be in compliance with the specifications. Any deviation from the specifications must be clearly indicated by the bidder. Alternates offered by the bidder as **EQUAL** to the specifications must be clearly defined. A bidder offering an alternate should attach complete specifications and literature to the bid. The Purchasing Division may waive minor deviations to specifications.
3. Complete all sections of the quotation form.
4. Unit prices shall prevail in case of discrepancy.
5. All quotations are considered F.O.B. destination unless alternate shipping terms are clearly identified in the quotation.
6. **BID SUBMISSION:** All quotations must be delivered by the bidder to the office listed below prior to the date and time of the bid opening. Failure of the bidder to deliver the quotations on time will result in bid disqualifications. Department of Administration, Purchasing Division, 2019 Washington Street East, P.O. Box 50130, Charleston, WV 25305-0130



State of West Virginia
 Department of Administration
 Purchasing Division
 2019 Washington Street East
 Post Office Box 50130
 Charleston, WV 25305-0130

Request for Quotation

RFQ NUMBER
WEH90053

PAGE
2

ADDRESS CORRESPONDENCE TO ATTENTION OF
ROBERTA WAGNER 304-558-0067

VENDOR

*709070313 02 304-757-7457
 SIEMENS HEALTHCARE DIAGNOSTICS
 211 BEECHWOOD ESTATES
 SCOTT DEPOT WV 25560

SHIP TO

HEALTH AND HUMAN RESOURCES
 WELCH COMMUNITY HOSPITAL
 454 MCDOWELL STREET
 WELCH, WV 24801 304-436-8710

DATE PRINTED	TERMS OF SALE	SHIP VIA	F.O.B.	FREIGHT TERMS
02/12/2009				

BID OPENING DATE: 02/26/2009 BTD OPENING TIME 01:30PM

LINE	QUANTITY	UOP	CAT NO.	ITEM NUMBER	UNIT PRICE	AMOUNT
<p>VENDOR MUST CLEARLY UNDERSTAND THAT ANY VERBAL REPRESENTATION MADE OR ASSUMED TO BE MADE DURING ANY ORAL DISCUSSION HELD BETWEEN VENDOR'S REPRESENTATIVES AND ANY STATE PERSONNEL IS NOT BINDING. ONLY THE INFORMATION ISSUED IN WRITING AND ADDED TO THE SPECIFICATIONS BY AN OFFICIAL ADDENDUM IS BINDING.</p> <p style="text-align: center;"> <i>Wuwan K. Stueve</i> SIGNATURE SIEMENS HEALTHCARE DIAGNOSTICS COMPANY 02/20/2009 DATE </p> <p>REV. 11/96</p> <p style="text-align: right;">END OF ADDENDUM NO. 1</p>						

SEE REVERSE SIDE FOR TERMS AND CONDITIONS

SIGNATURE <i>Wuwan K. Stueve</i>	TELEPHONE 847-236-7280	DATE 2/20/09
TITLE VP, SALES/CUSTOMER DES	FEIN 95-2802182	ADDRESS CHANGES TO BE NOTED ABOVE

WHEN RESPONDING TO RFQ, INSERT NAME AND ADDRESS IN SPACE ABOVE LABELED 'VENDOR'



State of West Virginia
 Department of Administration
 Purchasing Division
 2019 Washington Street East
 Post Office Box 50130
 Charleston, WV 25305-0130

Request for Quotation

RFQ NUMBER
WEH90053

PAGE
3

ADDRESS CORRESPONDENCE TO ATTENTION OF
ROBERTA WAGNER 304-558-0067

VENDOR

*709070313 02 304-757-7457
 SIEMENS HEALTHCARE DIAGNOSTICS
 211 BEECHWOOD ESTATES
 SCOTT DEPOT WV 25560

SHIP TO

HEALTH AND HUMAN RESOURCES
 WELCH COMMUNITY HOSPITAL
 454 MCDOWELL STREET
 WELCH, WV 24801 304-436-8710

DATE PRINTED	TERMS OF SALE	SHIP VIA	F.O.B.	FREIGHT TERMS
02/12/2009				

BID OPENING DATE: 02/26/2009 BID OPENING TIME 01:30PM

LINE	QUANTITY	UOP	CAT NO.	ITEM NUMBER	UNIT PRICE	AMOUNT
0001	1	JB		193-12		
REAGENTS (FOR AUTOMATIC INSTRUMENTS)						
***** THIS IS THE END OF RFQ WEH90053 ***** TOTAL:						\$213,330.71

SEE REVERSE SIDE FOR TERMS AND CONDITIONS

SIGNATURE <i>Durham K. Ineave</i>	TELEPHONE 847-236-7280	DATE 2/20/09
TITLE VP, SALES / CUSTOMER OPS	FAX 95-2802182	ADDRESS CHANGES TO BE NOTED ABOVE

WHEN RESPONDING TO RFQ, INSERT NAME AND ADDRESS IN SPACE ABOVE LABELED 'VENDOR'



State of West Virginia
 Department of Administration
 Purchasing Division
 2019 Washington Street East
 Post Office Box 50130
 Charleston, WV 25305-0130

Request for Quotation

RFQ NUMBER
 WEH90053

PAGE
 1

ADDRESS CORRESPONDENCE TO ATTENTION OF:
 ROBERTA WAGNER
 304-558-0067

VENDOR

*603160724 800-267-5387
 DADE BEHRING INC
 SET TO PURGE
 1717 DEERFIELD RD
 DEERFIELD IL 60015-0780

SHIP TO

HEALTH AND HUMAN RESOURCES
 WELCH COMMUNITY HOSPITAL
 454 MCDOWELL STREET
 WELCH, WV 24801 304-436-8710

DATE PRINTED	TERMS OF SALE	SHIP VIA	F.O.B.	FREIGHT TERMS
01/28/2009				

BID OPENING DATE: 02/26/2009 BID OPENING TIME 01:30PM

LINE	QUANTITY	UOP	CAT NO	ITEM NUMBER	UNIT PRICE	AMOUNT
				OPEN-END BLANKET CONTRACT		
	1	JB		193-12		
				REAGENTS (FOR AUTOMATIC INSTRUMENTS)		
				REQUEST FOR QUOTATION		
				TO PROVIDE AN OPEN END CONTRACT FOR REAGENTS TO PERFORM EXAMINATION FOR DETECTION OF SPECIFIED METHODS. SELECTED VENDOR MUST PROVIDE TWO FULLY AUTOMATED CHEMISTRY ANALYZERS AT NO ADDITIONAL CHARGE FOR USE WITH THE REQUESTED REAGENTS, PER THE ATTACHED SPECIFICATIONS. THE SYSTEMS MUST INCLUDE A COMPUTER, MONITOR, AND PRINTER WHICH WILL BE RETAINED AND MAINTAINED BY THE VENDOR.		
				THIS CONTRACT WILL BE FOR A PERIOD OF ONE YEAR WITH THE OPTION OF FOUR (4), ONE (1) YEAR RENEWALS.		
				EXHIBIT 3		

SEE REVERSE SIDE FOR TERMS AND CONDITIONS

SIGNATURE <i>Wuram K Shere</i>	TELEPHONE 847-236-7280	DATE 2/20/09
TITLE VP, SALES / CUSTOMER OPS	FEIN 95-2802182	ADDRESS CHANGES TO BE NOTED ABOVE

WHEN RESPONDING TO RFQ, INSERT NAME AND ADDRESS IN SPACE ABOVE LABELED 'VENDOR'



State of West Virginia
 Department of Administration
 Purchasing Division
 2019 Washington Street East
 Post Office Box 50130
 Charleston, WV 25305-0130

Request for Quotation

RFQ NUMBER
WEH90053

PAGE
2

ADDRESS CORRESPONDENCE TO ATTENTION OF:
ROBERTA WAGNER 304-558-0067

VENDOR

*603160724 800-267-5387
 DADE BEHRING INC
 SET TO PURGE
 1717 DEERFIELD RD
 DEERFIELD IL 60015-0780

SHIP TO

HEALTH AND HUMAN RESOURCES
 WELCH COMMUNITY HOSPITAL
 454 MCDOWELL STREET
 WELCH, WV
 24801 304-436-8710

DATE PRINTED	TERMS OF SALE	SHIP VIA	F.O.B	FREIGHT TERMS
01/28/2009				

BID OPENING DATE: 02/26/2009 BID OPENING TIME 01:30PM

LINE	QUANTITY	UOP	CAT NO	ITEM NUMBER	UNIT PRICE	AMOUNT
<p>LIFE OF CONTRACT: THIS CONTRACT BECOMES EFFECTIVE ON AWARD OF CONTRACT.. AND EXTENDS FOR A PERIOD OF ONE (1) YEAR OR UNTIL SUCH "REASONABLE TIME" THEREAFTER AS IS NECESSARY TO OBTAIN A NEW CONTRACT OR RENEW THE ORIGINAL CONTRACT. THE "REASONABLE TIME" PERIOD SHALL NOT EXCEED TWELVE (12) MONTHS. DURING THIS "REASONABLE TIME" THE VENDOR MAY TERMINATE THIS CONTRACT FOR ANY REASON UPON GIVING THE DIRECTOR OF PURCHASING 30 DAYS WRITTEN NOTICE.</p> <p>UNLESS SPECIFIC PROVISIONS ARE STIPULATED ELSEWHERE IN THIS CONTRACT DOCUMENT, THE TERMS, CONDITIONS AND PRICING SET HEREIN ARE FIRM FOR THE LIFE OF THE CONTRACT.</p> <p>RENEWAL: THIS CONTRACT MAY BE RENEWED UPON THE MUTUAL WRITTEN CONSENT OF THE SPENDING UNIT AND VENDOR, SUBMITTED TO THE DIRECTOR OF PURCHASING THIRTY (30) DAYS PRIOR TO THE EXPIRATION DATE. SUCH RENEWAL SHALL BE IN ACCORDANCE WITH THE TERMS AND CONDITIONS OF THE ORIGINAL CONTRACT AND SHALL BE LIMITED TO FOUR (4) ONE (1) YEAR PERIODS.</p> <p>CANCELLATION: THE DIRECTOR OF PURCHASING RESERVES THE RIGHT TO CANCEL THIS CONTRACT IMMEDIATELY UPON WRITTEN NOTICE TO THE VENDOR IF THE COMMODITIES AND/OR SERVICES SUPPLIED ARE OF AN INFERIOR QUALITY OR DO NOT CONFORM TO THE SPECIFICATIONS OF THE BID AND CONTRACT HEREIN.</p> <p>OPEN MARKET CLAUSE: THE DIRECTOR OF PURCHASING MAY AUTHORIZE A SPENDING UNIT TO PURCHASE ON THE OPEN MARKET, WITHOUT THE FILING OF A REQUISITION OR COST ESTIMATE, ITEMS SPECIFIED ON THIS CONTRACT FOR IMMEDIATE DELIVERY IN EMERGENCIES DUE TO UNFORESEEN CAUSES (INCLUDING BUT NOT LIMITED TO DELAYS IN TRANSPORTATION OR AN UNANTICIPATED INCREASE IN THE VOLUME</p>						

SEE REVERSE SIDE FOR TERMS AND CONDITIONS

SIGNATURE	Wmank Shure	TELEPHONE	847-236-7280	DATE	2/20/9
TITLE	VP, SALES/customer ops	FEIN	95-2802182	ADDRESS CHANGES TO BE NOTED ABOVE	

WHEN RESPONDING TO RFQ, INSERT NAME AND ADDRESS IN SPACE ABOVE LABELED 'VENDOR'



State of West Virginia
 Department of Administration
 Purchasing Division
 2019 Washington Street East
 Post Office Box 50130
 Charleston, WV 25305-0130

Request for Quotation

RFQ NUMBER
WEH90053

PAGE
3

ADDRESS CORRESPONDENCE TO ATTENTION OF
ROBERTA WAGNER 304-558-0067

VENDOR
 *603160724 800-267-5387
 DADE BEHRING INC
 SET TO PURGE
 1717 DEERFIELD RD
 DEERFIELD IL 60015-0780

SHIP TO
 HEALTH AND HUMAN RESOURCES
 WELCH COMMUNITY HOSPITAL
 454 MCDOWELL STREET
 WELCH, WV
 24801 304-436-8710

DATE PRINTED	TERMS OF SALE	SHIP VIA	F.O.B	FREIGHT TERMS
01/28/2009				

BID OPENING DATE: 02/26/2009 BID OPENING TIME 01:30PM

LINE	QUANTITY	UOP	CAT NO.	ITEM NUMBER	UNIT PRICE	AMOUNT
<p>OF WORK.)</p> <p>QUANTITIES: QUANTITIES LISTED IN THE REQUISITION ARE APPROXIMATIONS ONLY, BASED ON ESTIMATES SUPPLIED BY THE STATE SPENDING UNIT. IT IS UNDERSTOOD AND AGREED THAT THE CONTRACT SHALL COVER THE QUANTITIES ACTUALLY ORDERED FOR DELIVERY DURING THE TERM OF THE CONTRACT, WHETHER MORE OR LESS THAN THE QUANTITIES SHOWN.</p> <p>ORDERING PROCEDURE: SPENDING UNIT(S) SHALL ISSUE A WRITTEN STATE CONTRACT ORDER (FORM NUMBER WV-39) TO THE VENDOR FOR COMMODITIES COVERED BY THIS CONTRACT. THE ORIGINAL COPY OF THE WV-39 SHALL BE MAILED TO THE VENDOR AS AUTHORIZATION FOR SHIPMENT, A SECOND COPY MAILED TO THE PURCHASING DIVISION, AND A THIRD COPY RETAINED BY THE SPENDING UNIT.</p> <p>BANKRUPTCY: IN THE EVENT THE VENDOR/CONTRACTOR FILES FOR BANKRUPTCY PROTECTION, THIS CONTRACT IS AUTOMATICALLY NULL AND VOID, AND IS TERMINATED WITHOUT FURTHER ORDER.</p> <p>THE TERMS AND CONDITIONS CONTAINED IN THIS CONTRACT SHALL SUPERSEDE ANY AND ALL SUBSEQUENT TERMS AND CONDITIONS WHICH MAY APPEAR ON ANY ATTACHED PRINTED DOCUMENTS SUCH AS PRICE LISTS, ORDER FORMS, SALES AGREEMENTS OR MAINTENANCE AGREEMENTS, INCLUDING ANY ELECTRONIC MEDIUM SUCH AS CD-ROM.</p> <p>REV. 04/11/2001</p> <p>INQUIRIES WRITTEN QUESTIONS SHALL BE ACCEPTED THROUGH CLOSE OF BUSINESS ON 02/10/2009. QUESTIONS MAY BE SENT VIA USPS, FAX, COURIER OR E-MAIL. IN ORDER TO ASSURE NO VENDOR RECEIVES AN UNFAIR ADVANTAGE, NO SUBSTANTIVE QUESTIONS</p>						

SEE REVERSE SIDE FOR TERMS AND CONDITIONS

SIGNATURE <i>Wannan K. Stene</i>	TELEPHONE 847-236-7280	DATE 2/20/09
TITLE VP, SALES/CUSTOMER OPS	FEIN 95-2802182	ADDRESS CHANGES TO BE NOTED ABOVE

WHEN RESPONDING TO RFQ, INSERT NAME AND ADDRESS IN SPACE ABOVE LABELED 'VENDOR'



State of West Virginia
 Department of Administration
 Purchasing Division
 2019 Washington Street East
 Post Office Box 50130
 Charleston, WV 25305-0130

Request for Quotation

RFQ NUMBER
WEH90053

PAGE
4

ADDRESS CORRESPONDENCE TO ATTENTION OF
ROBERTA WAGNER 304-558-0067

VENDOR

*603160724 800-267-5387
 DADE BEHRING INC
 SET TO PURGE
 1717 DEERFIELD RD
 DEERFIELD IL 60015-0780

SHIP TO

HEALTH AND HUMAN RESOURCES
 WELCH COMMUNITY HOSPITAL
 454 MCDOWELL STREET
 WELCH, WV 24801 304-436-8710

DATE PRINTED	TERMS OF SALE	SHIP VIA	F.O.B.	FREIGHT TERMS
01/28/2009				

BID OPENING DATE: 02/26/2009 BID OPENING TIME 01:30PM

LINE	QUANTITY	UOP	CAT NO	ITEM NUMBER	UNIT PRICE	AMOUNT
<p>WILL BE ANSWERED ORALY. IF POSSIBLE, E-MAIL QUESTIONS ARE PREFERRED. ADDRESS INQUIRIES TO:</p> <p>ROBERTA WAGNER DEPARTMENT OF ADMINISTRATION PURCHASING DIVISION 2019 WASHINGTON STREET, EAST CHARLESTON, WV 25311</p> <p>FAX: 304-558-4115 E-MAIL: ROBERTA.A.WAGNER@WV.GOV</p> <p>PLEASE NOTE THIS IS A REBID OF WEH80221 & WEH80234.</p> <p>EXHIBIT 6</p> <p>PRICE ADJUSTMENT PROVISION: THE STATE OF WEST VIRGINIA WILL CONSIDER BIDS THAT CONTAIN PROVISIONS FOR PRICE ADJUSTMENTS PRIOR TO THE ORIGINAL EXPIRATION OF THE CONTRACT, PROVIDED THAT SUCH PRICE ADJUSTMENT COVERS BOTH UPWARD AND DOWNWARD MOVEMENT OF THE COMMODITY PRICE, AND THAT ADJUSTMENT IS BASED ON THE "PASS THROUGH" INCREASE OR DECREASE OF RAW MATERIALS AND/OR LABOR, WHICH MAKE UP ALL OR A SUBSTANTIAL PART OF A PRODUCT. ADJUSTMENTS ARE TO BE BASED UPON AN ACTUAL DOLLAR FIGURE, NOT A PERCENTAGE. ALL PRICE ADJUSTMENT REQUESTS MUST BE SUBSTANTIATED IN A MANNER ACCEPTABLE TO THE DIRECTOR PURCHASING, E.G. GOVERNMENTAL BENCH MARKS, GENERAL MARKET INCREASE, PUBLISHED PRICE LISTS. SUCH REQUESTS FOR AND INCREASE SHOULD BE RECEIVED IN WRITING BY THE DIRECTOR OF PURCHASING AT LEAST 30 DAYS IN ADVANCE OF THE EFFECTIVE DATE OF THE INCREASE. ANY TIME THE VENDOR REQUESTS A</p>						

SEE REVERSE SIDE FOR TERMS AND CONDITIONS

SIGNATURE <i>William K. Stover</i>	TELEPHONE 847-236-7280	DATE 2/20/9
TITLE VP, SALES / CUSTOMER OPS	FEIN 95-2802182	ADDRESS CHANGES TO BE NOTED ABOVE

WHEN RESPONDING TO RFQ, INSERT NAME AND ADDRESS IN SPACE ABOVE LABELED 'VENDOR'



State of West Virginia
 Department of Administration
 Purchasing Division
 2019 Washington Street East
 Post Office Box 50130
 Charleston, WV 25305-0130

Request for Quotation

RFQ NUMBER
WEH90053

PAGE
5

ADDRESS CORRESPONDENCE TO ATTENTION OF
ROBERTA WAGNER 304-558-0067

VENDOR

*603160724 800-267-5387
 DADE BEHRING INC
 SET TO PURGE
 1717 DEERFIELD RD
 DEERFIELD IL 60015-0780

SHIP TO

HEALTH AND HUMAN RESOURCES
 WELCH COMMUNITY HOSPITAL

 454 MCDOWELL STREET
 WELCH, WV
 24801 304-436-8710

DATE PRINTED	TERMS OF SALE	SHIP VIA	F.O.B	FREIGHT TERMS
01/28/2009				

BID OPENING DATE: 02/26/2009 BID OPENING TIME 01:30PM

LINE	QUANTITY	UOP	CAT NO.	ITEM NUMBER	UNIT PRICE	AMOUNT
<p>PRICE ADJUSTMENT, THE PURCHASING DIVISION MAY EITHER ACCEPT THE PRICE ADJUSTMENT AND AMEND THE CONTRACT ACCORDINGLY OR REJECT THE ADJUSTMENT IN ITS ENTIRETY AND CANCEL THE CONTRACT.</p> <p>PREFERRED TERMS: IT IS PREFERRED THAT THE PRICES ON THIS CONTRACT ARE FIRM FOR LIFE OF THE CONTRACT, AS INDICATED IN THE LIFE OF CONTRACT CLAUSE CONTAINED HEREIN, NOT TO EXCEED ONE (1) YEAR. <i>SIEMENS AGREES.</i></p> <p>IF THE VENDOR CANNOT GUARANTEE A FIRM PRICE FOR THE LIFE OF CONTRACT, HE MUST INDICATE ONE OF THE PARAGRAPHS LISTED BELOW. FAILURE TO QUALIFY THE PREFERRED TERMS WILL BIND THE VENDOR TO A FIRM PRICE FOR THE LIFE OF THE CONTRACT.</p> <p>ALTERNATE TERMS: <i>(NOT APPLICABLE)</i></p> <p>() THE PRICES ON THIS CONTRACT WILL REMAIN FIRM FOR DAYS AFTER THE EFFECTIVE DATE OF THE CONTRACT. PRICES WILL REMAIN FIRM AFTER EACH PRICE ADJUSTMENT FOR A MINIMUM OF DAYS.</p> <p>() THE VENDOR DOES NOT AGREE TO MAINTAIN A FIRM PRICE FOR THE LENGTH OF THE CONTRACT BUT OFFERS AN ALTERNATE PROPOSAL AS FOLLOWS: </p> <p>THE MODEL/BRAND/SPECIFICATIONS NAMED HEREIN ESTABLISH THE ACCEPTABLE LEVEL OF QUALITY ONLY AND ARE NOT INTENDED TO REFLECT A PREFERENCE OR FAVOR ANY</p>						

SEE REVERSE SIDE FOR TERMS AND CONDITIONS

SIGNATURE <i>Wmiam K Stree</i>	TELEPHONE 847-236-7280	DATE 2/20/09
TITLE VP, SALES/CUSTOMER OPS	FEIN 95-2802182	ADDRESS CHANGES TO BE NOTED ABOVE

WHEN RESPONDING TO RFQ, INSERT NAME AND ADDRESS IN SPACE ABOVE LABELED 'VENDOR'



State of West Virginia
 Department of Administration
 Purchasing Division
 2019 Washington Street East
 Post Office Box 50130
 Charleston, WV 25305-0130

Request for Quotation

RFQ NUMBER
WEH90053

PAGE
6

ADDRESS CORRESPONDENCE TO ATTENTION OF
ROBERTA WAGNER 304-558-0067

*603160724 800-267-5387
 VENDOR
 DADE BEHRING INC
 SET TO PURGE
 1717 DEERFIELD RD
 DEERFIELD IL 60015-0780

SHIP TO
 HEALTH AND HUMAN RESOURCES
 WELCH COMMUNITY HOSPITAL
 454 MCDOWELL STREET
 WELCH, WV
 24801 304-436-8710

DATE PRINTED	TERMS OF SALE	SHIP VIA	F.O.B	FREIGHT TERMS
01/28/2009				

BID OPENING DATE: 02/26/2009 BID OPENING TIME 01:30PM

LINE	QUANTITY	UOP	CAT NO.	ITEM NUMBER	UNIT PRICE	AMOUNT
<p>PARTICULAR BRAND OR VENDOR. VENDORS WHO ARE BIDDING ALTERNATES SHOULD SO STATE AND INCLUDE PERTINENT LITERATURE AND SPECIFICATIONS. FAILURE TO PROVIDE INFORMATION FOR ANY ALTERNATES MAY BE GROUNDS FOR REJECTION OF THE BID. THE STATE RESERVES THE RIGHT TO WAIVE MINOR IRREGULARITIES IN BIDS OR SPECIFICATION IN ACCORDANCE WITH SECTION 148-1-4 (F) OF THE WEST VIRGINIA LEGISLATIVE RULES AND REGULATIONS.</p> <p>PURCHASING CARD ACCEPTANCE: THE STATE OF WEST VIRGINIA CURRENTLY UTILIZES A VISA PURCHASING CARD PROGRAM WHICH IS ISSUED THROUGH A BANK. THE SUCCESSFUL VENDOR MUST ACCEPT THE STATE OF WEST VIRGINIA VISA PURCHASING CARD FOR PAYMENT OF ALL ORDERS PLACED BY ANY STATE AGENCY AS A CONDITION OF AWARD.</p> <p>NOTICE</p> <p>A SIGNED BID MUST BE SUBMITTED TO:</p> <p>DEPARTMENT OF ADMINISTRATION PURCHASING DIVISION BUILDING 15 2019 WASHINGTON STREET, EAST CHARLESTON, WV 25305-0130</p> <p>PLEASE NOTE: A CONVENIENCE COPY WOULD BE APPRECIATED.</p> <p>THE BID SHOULD CONTAIN THIS INFORMATION ON THE FACE OF THE ENVELOPE OR THE BID MAY NOT BE CONSIDERED:</p> <p>SEALED BID</p>						

SEE REVERSE SIDE FOR TERMS AND CONDITIONS

SIGNATURE <i>William K. Steen</i>	TELEPHONE 847-236-7280	DATE 2/20/09
TITLE VP, SALES / CUSTOMER OPS	FEIN 95-2802182	ADDRESS CHANGES TO BE NOTED ABOVE

WHEN RESPONDING TO RFQ, INSERT NAME AND ADDRESS IN SPACE ABOVE LABELED 'VENDOR'



State of West Virginia
 Department of Administration
 Purchasing Division
 2019 Washington Street East
 Post Office Box 50130
 Charleston, WV 25305-0130

**Request for
 Quotation**

RFQ NUMBER
WEH90053

PAGE
7

ADDRESS CORRESPONDENCE TO ATTENTION OF
ROBERTA WAGNER 304-558-0067

*603160724 800-267-5387
 DADE BEHRING INC
 SET TO PURGE
 1717 DEERFIELD RD
 DEERFIELD IL 60015-0780

V
E
N
D
O
R

HEALTH AND HUMAN RESOURCES
 WELCH COMMUNITY HOSPITAL

S
H
I
P
T
O

454 MCDOWELL STREET
 WELCH, WV 24801 304-436-8710

DATE PRINTED	TERMS OF SALE	SHIP VIA	F.O.B.	FREIGHT TERMS
01/28/2009				

BID OPENING DATE: 02/26/2009 BID OPENING TIME 01:30PM

LINE	QUANTITY	UOP	CAT NO.	ITEM NUMBER	UNIT PRICE	AMOUNT
BUYER: -----RW/FILE 22-----						
RFQ. NO.: -----WEH90053-----						
BID OPENING DATE: -----2/26/2009-----						
BID OPENING TIME: -----1:30 PM-----						
PLEASE PROVIDE A FAX NUMBER IN CASE IT IS NECESSARY TO CONTACT YOU REGARDING YOUR BID:						
----- FAX: 304-757-0204 -----						
CONTACT PERSON (PLEASE PRINT CLEARLY):						
----- SALLY JONES -----						
----- Phone: 304-541-5413 -----						
***** THIS IS THE END OF RFQ WEH90053 *****						TOTAL: \$ 213,330.71

SEE REVERSE SIDE FOR TERMS AND CONDITIONS

SIGNATURE <i>William K. Stevens</i>	TELEPHONE 847-236-7280	DATE 2/20/09
TITLE VP, SALES/CUSTOMER OPS FEIN 95-2802182	ADDRESS CHANGES TO BE NOTED ABOVE	

WHEN RESPONDING TO RFQ, INSERT NAME AND ADDRESS IN SPACE ABOVE LABELED 'VENDOR'

STATE OF WEST VIRGINIA
Purchasing Division**PURCHASING AFFIDAVIT****VENDOR OWING A DEBT TO THE STATE:**

West Virginia Code §5A-3-10a provides that: No contract or renewal of any contract may be awarded by the state or any of its political subdivisions to any vendor or prospective vendor when the vendor or prospective vendor or a related party to the vendor or prospective vendor is a debtor and the debt owed is an amount greater than one thousand dollars in the aggregate.

PUBLIC IMPROVEMENT CONTRACTS & DRUG-FREE WORKPLACE ACT:

If this is a solicitation for a public improvement construction contract, the vendor, by its signature below, affirms that it has a written plan for a drug-free workplace policy in compliance with Article 1D, Chapter 21 of the *West Virginia Code*. The vendor **must** make said affirmation with its bid submission. Further, public improvement construction contract may not be awarded to a vendor who does not have a written plan for a drug-free workplace policy in compliance with Article 1D, Chapter 21 of the *West Virginia Code* and who has not submitted that plan to the appropriate contracting authority in timely fashion. For a vendor who is a subcontractor, compliance with Section 5, Article 1D, Chapter 21 of the *West Virginia Code* may take place before their work on the public improvement is begun.

ANTITRUST:

In submitting a bid to any agency for the state of West Virginia, the bidder offers and agrees that if the bid is accepted the bidder will convey, sell, assign or transfer to the state of West Virginia all rights, title and interest in and to all causes of action it may now or hereafter acquire under the antitrust laws of the United States and the state of West Virginia for price fixing and/or unreasonable restraints of trade relating to the particular commodities or services purchased or acquired by the state of West Virginia. Such assignment shall be made and become effective at the time the purchasing agency tenders the initial payment to the bidder.

I certify that this bid is made without prior understanding, agreement, or connection with any corporation, firm, limited liability company, partnership or person or entity submitting a bid for the same materials, supplies, equipment or services and is in all respects fair and without collusion or fraud. I further certify that I am authorized to sign the certification on behalf of the bidder or this bid.

LICENSING:

Vendors must be licensed and in good standing in accordance with any and all state and local laws and requirements by any state or local agency of West Virginia, including, but not limited to, the West Virginia Secretary of State's Office, the West Virginia Tax Department, West Virginia Insurance Commission, or any other state agencies or political subdivision. Furthermore, the vendor must provide all necessary releases to obtain information to enable the Director or spending unit to verify that the vendor is licensed and in good standing with the above entities.

CONFIDENTIALITY:

The vendor agrees that he or she will not disclose to anyone, directly or indirectly, any such personally identifiable information or other confidential information gained from the agency, unless the individual who is the subject of the information consents to the disclosure in writing or the disclosure is made pursuant to the agency's policies, procedures and rules. Vendor further agrees to comply with the Confidentiality Policies and Information Security Accountability Requirements, set forth in <http://www.state.wv.us/admin/purchase/privacy/noticeConfidentiality.pdf>.

Under penalty of law for false swearing (*West Virginia Code* §61-5-3), it is hereby certified that the vendor affirms and acknowledges the information in this affidavit and is in compliance with the requirements as stated.

Vendor's Name: SIEMENS HEALTHCARE DIAGNOSTICSAuthorized Signature: William K. StrelkeDate: 2/20/2009

Purchasing Affidavit (Revised 01/01/09) WILLIAM STRELKE,
VP, SALES / CUSTOMER OPS

VENDOR PREFERENCE CERTIFICATE

Certification and application* is hereby made for Preference in accordance with West Virginia Code, §5A-3-37. (Does not apply to construction contracts). West Virginia Code, §5A-3-37, provides an opportunity for qualifying vendors to request (at the time of bid) preference for their residency status. Such preference is an evaluation method only and will be applied only to the cost bid in accordance with the West Virginia Code. This certificate for application is to be used to request such preference. The Purchasing Division will make the determination of the Resident Vendor Preference, if applicable.

- 1. Application is made for 2.5% resident vendor preference for the reason checked: Bidder is an individual resident vendor and has resided continuously in West Virginia for four (4) years immediately preceding the date of this certification; or, Bidder is a partnership, association or corporation resident vendor and has maintained its headquarters or principal place of business continuously in West Virginia for four (4) years immediately preceding the date of this certification; or 80% of the ownership interest of Bidder is held by another individual, partnership, association or corporation resident vendor who has maintained its headquarters or principal place of business continuously in West Virginia for four (4) years immediately preceding the date of this certification; or, Bidder is a nonresident vendor which has an affiliate or subsidiary which employs a minimum of one hundred state residents and which has maintained its headquarters or principal place of business within West Virginia continuously for the four (4) years immediately preceding the date of this certification; or,
2. Application is made for 2.5% resident vendor preference for the reason checked: Bidder is a resident vendor who certifies that, during the life of the contract, on average at least 75% of the employees working on the project being bid are residents of West Virginia who have resided in the state continuously for the two years immediately preceding submission of this bid; or,
3. Application is made for 2.5% resident vendor preference for the reason checked: Bidder is a nonresident vendor employing a minimum of one hundred state residents or is a nonresident vendor with an affiliate or subsidiary which maintains its headquarters or principal place of business within West Virginia employing a minimum of one hundred state residents who certifies that, during the life of the contract, on average at least 75% of the employees or Bidder's affiliate's or subsidiary's employees are residents of West Virginia who have resided in the state continuously for the two years immediately preceding submission of this bid; or,
4. Application is made for 5% resident vendor preference for the reason checked: Bidder meets either the requirement of both subdivisions (1) and (2) or subdivision (1) and (3) as stated above; or,
5. Application is made for 3.5% resident vendor preference who is a veteran for the reason checked: Bidder is an individual resident vendor who is a veteran of the United States armed forces, the reserves or the National Guard and has resided in West Virginia continuously for the four years immediately preceding the date on which the bid is submitted; or,
6. Application is made for 3.5% resident vendor preference who is a veteran for the reason checked: Bidder is a resident vendor who is a veteran of the United States armed forces, the reserves or the National Guard, if, for purposes of producing or distributing the commodities or completing the project which is the subject of the vendor's bid and continuously over the entire term of the project, on average at least seventy-five percent of the vendor's employees are residents of West Virginia who have resided in the state continuously for the two immediately preceding years.

Bidder understands if the Secretary of Revenue determines that a Bidder receiving preference has failed to continue to meet the requirements for such preference, the Secretary may order the Director of Purchasing to: (a) reject the bid; or (b) assess a penalty against such Bidder in an amount not to exceed 5% of the bid amount and that such penalty will be paid to the contracting agency or deducted from any unpaid balance on the contract or purchase order.

By submission of this certificate, Bidder agrees to disclose any reasonably requested information to the Purchasing Division and authorizes the Department of Revenue to disclose to the Director of Purchasing appropriate information verifying that Bidder has paid the required business taxes, provided that such information does not contain the amounts of taxes paid nor any other information deemed by the Tax Commissioner to be confidential.

Under penalty of law for false swearing (West Virginia Code, §61-5-3), Bidder hereby certifies that this certificate is true and accurate in all respects; and that if a contract is issued to Bidder and if anything contained within this certificate changes during the term of the contract, Bidder will notify the Purchasing Division in writing immediately.

Bidder: SIEMENS HEALTHCARE DIAGNOSTICS signed: William K. Steele
Date: 2/20/2009 Title: VP, SALES / CUSTOMER OPS

*Check any combination of preference consideration(s) indicated above, which you are entitled to receive.

BUYER:
BID OPENING DATE:
BID OPENING TIME:

SEALED BID
RW / FILE 22
2/26/2009
1:30PM

ORIGINAL

RECEIVED

2009 FEB 26 PM 1:20

Welch Community Hospital
Response to RFQ# WEH90053
February 26, 2009

WV PURCHASING
DIVISION

Submitted by: **Siemens Healthcare Diagnostics Inc.**
Contact: **Sally Jones, Chemistry Sales Representative**
Contact Phone Number: **304-541-5413**
Contact Fax Number: **304-757-0204**

SIEMENS

This Siemens Healthcare Diagnostics RFQ response has been presented to comply with **all** the specifications listed in the WEH90053 Bid Request.

All the listed General Terms & Conditions in WEH90053 have been agreed to by Siemens Healthcare Diagnostics.

All the listed Instructions to Bidders in WEH90053 have been reviewed and agreed to by Siemens Healthcare Diagnostics.

The Procurement Specifications have been reviewed and our RFQ response meets those specifications in total at 100%.

This Addendum is to clarify any potential areas that may seem to conflict with the specifications listed on the State Bid # WEH90053.

Response to RFQ specification number 7, that the test kits have a minimum shelf life of 90 days beyond date of receipt. Siemens test kits typically have a year or more shelf life when shipped. As our shipping center does not release test kits with less than 90 days, the wording on this reply states the guarantee as can be controlled by our shipping department – so the phrasing in our reply states ‘from the date of shipment’. If there was ever a time when Welch Community Hospital received any test kit that had, upon the date received, less than 90 days all the Laboratory needs to do is notify the Sales Representative who would send in the replacement test kit at no charge. Siemens guarantees shelf life on their test kits at 90 days.

Response to RFQ specification number 10, all products and equipment are to be quoted FOB destination, unless otherwise stated in vendor’s quotation. Currently, Welch has one (1) no charge standard shipment per month – this bid has extended that offer to two (2) no charge standard shipments per month. Additional information on Shipping and Freight are included under the next to last Tab labeled Shipping & Freight Policy. Equipment is FOB Destination.

Detail explanation of Bid/Price Sheet Notes.

Welch Community Hospital has been using our Dimension analyzers for well over 10 years. The Unit # shown on the Bid Sheet (as sent to us) has changed for some of the items (all items have an asterisk written in on our Bid Sheet reply). The Unit # can sometimes change over time. All of our responses showing a different Unit # are for the SAME method requested in the Description column and the SAME methodology requested in the Bid. Counts per Unit remain exactly the same as what is reflected on the Bid Sheet.

It should be noted that Line 7 for 20 Units of Glucose with Unit # DF40 at 960 test per units has always been our Unit #DF39A (which has 960 test per unit) – the Glucose with Unit # DF40 has 1440 test per unit and is listed on line 97. These are both the same Glucose method and the same Glucose methodology. Siemens has quoted the exact number of Glucose tests requested in this bid. Both Glucose unit prices are the same @ \$0.198.

SIEMENS

WEH90053 Blanket Contract for Reagents/Consumables for use in Two Chemistry Analyzers.

February 26, 2009

Roberta Wagner
Department of Administration
Purchasing Division
2019 Washington Street, East
PO Box 50130
Charleston, WV 25305-0130

Re: RFQ# WEH90053, Chemistry Analyzers

Dear Ms. Wagner,

Thank you for the opportunity to participate in this RFQ for Welch Community Hospital.

Through the combination of Dade Behring, Bayer HealthCare Diagnostics, and Diagnostic Products Corporation, Siemens Healthcare Diagnostics now offers the most comprehensive test menu in the industry with a strong focus on testing for specific disease-states, and is the leading clinical diagnostics company.

In this RFQ response, we introduce our portfolio of performance-driven systems, unmatched menu offering, service and support, all designed to streamline workflow, enhance operational efficiency and support improved patient care.

Siemens Healthcare Diagnostics is committed to our "customer-first" culture, which is at the heart of everything we do. Our experienced and dedicated professionals are personally committed to consistently delivering world-class service and support, valuing long-term relationships built on trust. Your team of Siemens dedicated and experienced professionals is committed to listening carefully to your needs, understanding your specific challenges and supporting you with solutions that deliver tangible value for your operations.

We look forward to providing you with additional information about our company, and invite you to visit our website at www.siemens.com/diagnostics. Together, we can take diagnostics to the next level.

Thank You,

Sally Jones

Chemistry Sales Representative



Siemens Healthcare Diagnostics Inc.

1717 Deerfield Rd.
Deerfield, IL 60015

847-267-5300
www.siemens.com/diagnostics

All information provided in this RFQ response is proprietary and is not to be disclosed to a third party without express written permission from Siemens Healthcare Diagnostics, except as detailed herein.

WEH90053 Blanket Contract for Reagents/Consumables for use in Two Chemistry Analyzers.

All information provided in this RFQ response is proprietary and is not to be disclosed to a third party without express written permission from Siemens Healthcare Diagnostics, except as detailed herein.

The information contained in this response was prepared expressly for your institution. Siemens Healthcare Diagnostics Inc. (Siemens) considers this information to be proprietary and confidential unless indicated otherwise.

By receiving the response that you solicited your institution agrees to retain in strict confidence all information contained herein. The information shall only be reproduced and used by your institution for evaluating the merits of a business relationship with Siemens. If consultants are being utilized to help evaluate this potential relationship, your institution agrees that it will take measures necessary with such consultants, by agreement or otherwise, to protect the confidentiality of Siemens' response.

SIEMENS

WEH90053 Blanket Contract for Reagents/Consumables for use in Two Chemistry Analyzers.

Welch Community Hospital

February 26, 2009

Table of Contents

Siemens Healthcare Diagnostics Inc. (Siemens) Response Dimension[®] RxL Max[®] with HM Systems

RFQ General Terms and Conditions

Response to RFQ Bid, original page numbers 8 through 13
Including References and Responses to Technical Questions

PRICE EXHIBIT - Bid Sheets

Authorized Signature Pages (9)

Request for Quotation, pages 1 through 7

Vendor Preference Certificate

Purchasing Affidavit

Bid Addendum with Authorized Signatures

Additional Vendor Exhibits:

Exhibit 1 Instrument Specifications and Brochure

Exhibit 2 Shipping and Freight Policy, Reagents and Consumables

Exhibit 3 References

*Please also find these references on page 7 of Siemens' RFQ response,
and behind the Price Exhibit tab of this binder.*

SIEMENS

WEH90053 Blanket Contract for Reagents/Consumables for use in Two Chemistry Analyzers.

GENERAL TERMS & CONDITIONS

REQUEST FOR QUOTATION (RFQ) AND REQUEST FOR PROPOSAL (RFP)

1. Awards will be made in the best interest of the State of West Virginia.

Siemens agrees.

2. The State may accept or reject in part, or in whole, any bid.

Siemens agrees.

3. All quotations are governed by the *West Virginia Code* and the *Legislative Rules* of the Purchasing Division.

Siemens agrees.

4. Prior to any award, the apparent successful vendor must be properly registered with the Purchasing Division and have paid the required \$125 fee.

Siemens agrees and is properly registered as a vendor with the Purchasing Division.

5. All services performed or goods delivered under State Purchase Order/Contracts are to be continued for the term of the Purchase Order/Contracts, contingent upon funds being appropriated by the Legislature or otherwise being made available. In the event funds are not appropriated or otherwise available for these services or goods, this Purchase Order/Contract becomes void and of no effect after June 30.

Siemens agrees.

6. Payment may only be made after the delivery and acceptance of goods or services.

Siemens agrees.

7. Interest may be paid for late payment in accordance with the *West Virginia Code*.

Siemens agrees.

8. Vendor preference will be granted upon written request in accordance with the *West Virginia Code*.

Siemens agrees.

9. The State of West Virginia is exempt from federal and state taxes and will not pay or reimburse such taxes.

Siemens agrees. And, if this would ever change in the future, Siemens would be pleased to again discuss tax exemption status with the State of West Virginia.

In the event that any taxes are outside the scope of the tax exemption certificate, the State would remain responsible for such taxes. However, if during this Agreement Siemens would receive property tax bills for the State of West Virginia in connection to Welch Community Hospital, Siemens also agrees to not invoice the customer for such property tax.

10. The Director of Purchasing may cancel any Purchase Order/Contract upon 30 days written notice to the seller.

Siemens agrees.

11. The laws of the State of West Virginia and the *Legislative Rules* of the Purchasing Division shall govern all rights and duties under the Contract, including without limitation the validity of this Purchase Order/Contract.

Siemens agrees.

12. Any reference to automatic renewal is hereby deleted. The Contract may be renewed only upon mutual written agreement of the parties.

Siemens agrees.

All information provided in this RFQ response is proprietary and is not to be disclosed to a third party without express written permission from Siemens Healthcare Diagnostics, except as detailed herein.

SIEMENS

WEH90053 Blanket Contract for Reagents/Consumables for use in Two Chemistry Analyzers.

13. **BANKRUPTCY:** In the event the vendor/contractor files for bankruptcy protection, this Contract may be deemed null and void, and terminated without further order.

Siemens agrees.

14. **HIPAA BUSINESS ASSOCIATE ADDENDUM:** The West Virginia State Government HIPAA Business Associate Addendum (BAA), approved by the Attorney General, and available online at the Purchasing Division's web site (<http://www.state.wv.us/admin/purchase/vrc/hipaa.htm>) is hereby made part of the agreement. Provided that, the Agency meets the definition of a Cover Entity (45 CFR §160.103) and will be disclosing Protected Health Information (45 CFR §160.103) to the vendor.

Siemens agrees.

15. **WEST VIRGINIA ALCOHOL & DRUG-FREE WORKPLACE ACT:** If this Contract constitutes a public improvement construction contract as set forth in Article 1 D, Chapter 21 of the West Virginia Code ("The West Virginia Alcohol and Drug-Free Workplace Act"), then the following language shall hereby become part of this Contract: "The contractor and its subcontractors shall implement and maintain a written drug-free workplace policy in compliance with the West Virginia Alcohol and Drug-Free Workplace Act, as set forth in Article 1 D, Chapter 21 of the West Virginia Code. The contractor and its subcontractors shall provide a sworn statement in writing, under the penalties of perjury, that they maintain a valid drug-free work place policy in compliance with the West Virginia and Drug-Free Workplace Act. It is understood and agreed that this Contract shall be cancelled by the awarding authority if the Contractor: 1) Fails to implement its drug-free workplace policy; 2) Fails to provide information regarding implementation of the contractor's drug-free workplace policy at the request of the public authority; or 3) Provides to the public authority false information regarding the contractor's drug-free workplace policy."

Siemens agrees.

SIEMENS

WEH90053 Blanket Contract for Reagents/Consumables for use in Two Chemistry Analyzers.

INSTRUCTIONS TO BIDDERS

1. Use the quotation forms provided by the Purchasing Division.

Siemens agrees.

2. SPECIFICATIONS: Items offered must be in compliance with the specifications. Any deviation from the specifications must be clearly indicated by the bidder. Alternates offered by the bidder as EQUAL to the specifications must be clearly defined. A bidder offering an alternate should attach complete specifications and literature to the bid. The Purchasing Division may waive minor deviations to specifications.

Siemens agrees.

3. Complete all sections of the quotation form.

Siemens agrees.

4. Unit prices shall prevail in case of discrepancy.

Siemens agrees.

5. All quotations are considered F.O.B. destination unless alternate shipping terms are clearly identified in the quotation.

Siemens agrees. Prices presented here include instrument shipping, FOB destination, freight pre-paid and absorbed by Siemens.

Welch currently enjoys one standard reagent and consumables shipment per month at no charge. Siemens is now able to extend this enhanced offer as follows:

Prices included in this proposal include shipping and freight for up to two (2) standard reagent and consumable orders each month during this Agreement.

Beyond the first two standard shipments per month, reagent and consumable shipping will be in accordance with our current standard Shipping & Freight policy, attached here as Exhibit 2 for your convenience. Standard shipments are F.O.B Destination.

6. BID SUBMISSION: All quotations must be delivered by the bidder to the office listed below prior to the date and time of the bid opening. Failure of the bidder to deliver the quotations on time will result in bid disqualifications:

Department of Administration, Purchasing Division,
2019 Washington Street East, P.O. Box 50130,
Charleston, WV 25305-0130
Siemens agrees.

SIEMENS

WEH90053 Blanket Contract for Reagents/Consumables for use in Two Chemistry Analyzers.

Welch Community Hospital
RFQ #WEH90053

GENERAL INFORMATION

Project:

To obtain a Vendor who will provide two (2) new chemistry analyzers (free of charge) and supply/sell reagents/consumables for use with the new chemistry analyzers. The vendor will retain ownership of the analyzers and will maintain the analyzers in working order to allow the facility to use them with the requested reagents/consumables.

PROCUREMENT SPECIFICATIONS

General Requirements:

Vendor shall provide, at no charge, two (2) fully automated chemistry analyzers, (Dade RxL Max Systems or equal) for use with requested reagents/consumables. Vendor must provide a complete analyzer system that will include a computer, monitor, printer and any accessories which will be retained and maintained by the vendor.

Please see the attached Price exhibits for full proposal details, which include two (2) complete analyzer systems, computer, monitor, printer and accessories needed to operate the systems, including Millipore System (1), the titles of which will all be retained by Siemens.

There will be no capital outlay required by Welch Community Hospital for the equipment included in this proposal. Please see the attached Price Exhibit for additional details.

Service will be the responsibility of Siemens according to the 24 Plus Service Agreement terms. Prices provided in this proposal include one year of warranty service, and four (4) years of post-warranty service in the form of the Siemens 24 Plus Service Agreement.

For full service details, please see Siemens' response to Scope of Work, question 5, below.

Welch Community Hospital desires a Vendor with a proven track record for providing necessary supplies and maintaining of equipment. Vendor must have provided such services for at least three (3) years. Vendor shall provide references of at least three (3) clients for which they have provided these similar services.

Siemens has a successful history of providing necessary supplies and maintaining equipment to Welch Community Hospital for over 10 years.

References

Williamson Memorial Hospital
859 Alderson Street
Williamson, WV 25661
Kandi Justice, Lab Manager
304-235-2500 x130

Raleigh General Hospital
1710 Harper Road
Beckley, WV 25801
Janet Halstead, Laboratory Manager
304-256-4157

Williamson ARH Hospital
260 Hospital Drive
South Williamson, KY 41503
LeAnn Hubbard, Laboratory Manager
606-237-1736

Please also find these references as attached Vendor Exhibit 3, and behind the Price Exhibit tab of this binder.

All information provided in this RFQ response is proprietary and is not to be disclosed to a third party without express written permission from Siemens Healthcare Diagnostics, except as detailed herein.

SIEMENS

WEH90053 Blanket Contract for Reagents/Consumables for use in Two Chemistry Analyzers.

Scope of Work:

Vendor shall provide two (2) new chemistry analyzers/ equipment and reagent/consumables as needed for the Laboratory at Welch Community Hospital. Vendor shall include, but not be limited to the following requirements:

1. The equipment shall be a single platform that can perform all our test methods.

Siemens meets this requirement.

The Dimension® RxL Max® with HM can perform 100% of the tests listed on the required test menu in this bid.

In 1997, Siemens (formerly Dade Behring) was the first company to introduce the combination of Chemistry and Immunochemistry on a single consolidated platform.

2. There shall be full mirror image back-up feature to assure that critical tests have a back-up platform in the event that a primary analyzer is not functional.

Siemens meets this requirement.

This proposal includes two Dimension® RxL Max® with HM Systems, which provide full mirror image back-up. During a routine preventive maintenance visit or if one instrument is not functional, the full mirror image will provide the critical and routine tests needed.

3. The system must have monitors that notify when STAT tests are completed. It must also monitor the amount of product still available in the equipment to reduce the amount of waste reagents. The system shall also allow for reagents to be added while maintaining on-going system operation.

Siemens meets this requirement.

The Dimension® RxL Max® with HM System has five Alert Screens that notify the operator in relation to STATs (showing when the STAT tests are completed), Samples, Supplies (providing Reagent Monitoring which shows the available product in the analyzer allowing less waste), QC and Calibration. Reagents can be added while the analyzer is operating, in an on-going operation.

The STAT Alert screen will show the status of all STAT samples on the analyzer. This helps to reduce pre-analytical delays. Please refer to Table 1, and to Figures 1 and 2, below for more information on this function.

Table 1: Display Modes for STAT Sample Screen. There are four display modes for the STAT Sample screen, depending on the customized configuration.

Mode	Displays
Show All	Displays all STAT samples, regardless of status
Show Completed	Display all completed STAT Samples
Show Processing	Display all STAT samples currently processing. The "When Available" field is updated every five seconds. When a sample is completed, it is removed from this list.
STATS Not Started	Displays STAT samples entered but not started within a specified time period

All information provided in this RFQ response is proprietary and is not to be disclosed to a third party without express written permission from Siemens Healthcare Diagnostics, except as detailed herein.

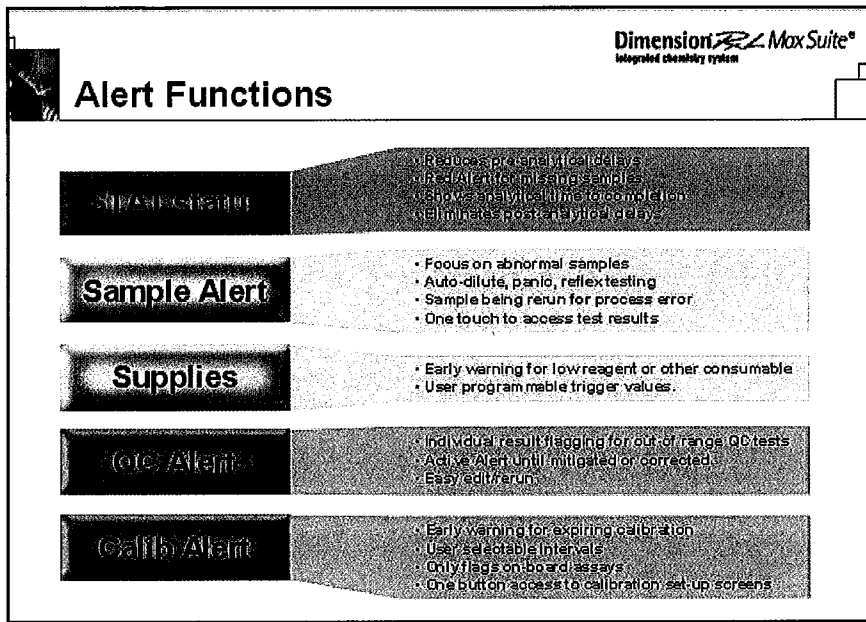

Figure 1: Five Alert Functions

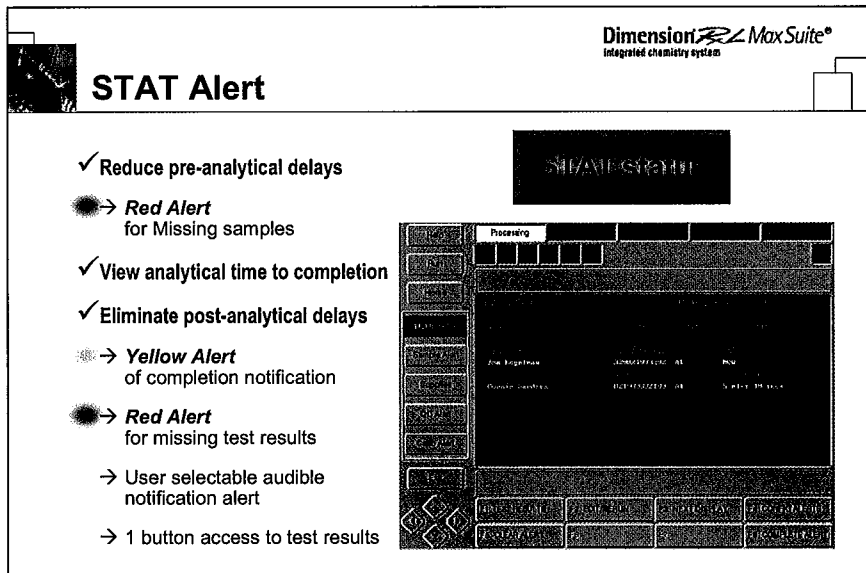

Figure 2: The Stat Alert Screen

Reagent Monitoring

When the Flex® reagent cartridges are loaded into the inventory, the software begins to count the number of tests used and the time on the system. As the reagent wells expire or are used up, the system will move to a fresh reagent well. When the Flex® reagent cartridge is used up or it expires, the system will expel the Flex® reagent cartridge and it will not allow it to be reinserted. When user-defined tests are added to the system, the number of tests per well is typed into the software and it will monitor the reagent usage just as it does for Dimension® reagents. Please refer to Figure 3 below for more information on the Reagent Inventory Screen.

SIEMENS

WEH90053 Blanket Contract for Reagents/Consumables for use in Two Chemistry Analyzers.

OPERATING MENU		Press F4: SYSTEM PREP				
SYSTEM PREPARATION MENU		Press F1: INVENTORY				
REAGENT CARTRIDGE INVENTORY						Empty Slots: 79
17:02:24 Jan 13 1999						
METHOD	LOT NUMBER	SEQUENCE NO.	TESTS LEFT	CALIB EXP. DATE	SYSTEM EXP. DATE	IN USE
ABS	CA1079	31747	0	14:44 Jul 28	00:00 Mar 21	NO
ABS	CA1079	31236	15	14:44 Jul 28	00:00 Mar 21	NO
BUN	LA0356	17074	100	11:09 Aug 18	14:27 Aug 5	NO
CREA	KN0316	18321	18	11:16 Oct 17	09:49 Aug 17	NO
GLU	NA1040	02913	18	13:45 Aug 9	09:13 Aug 6	NO
LDH	XB0286	08656	45	09:22 Oct 18	09:13 Aug 6	NO
PHOS	KA0314	03367	110	14:42 Aug 3	09:13 Aug 6	YES
PTN	CA1000	02238	90	13:02 Aug 18	09:12 Aug 6	NO
F1: SHOW HOLDS		F2:		F3: REMOVE REAG		F4: ADD REAGENT
F5: PRINT		F6: FIX INVENTORY		F7: REMOVE ZERO'D		F8: REMOVE ALL

Figure 3: Reagent Cartridge Inventory Screen

Reagent Loading

Reagents can be added at any time, while the system is in motion or processing samples, calibrating, etc. Operators can load without pausing the instrument or waiting for a "Load Mode Status" before adding reagents.

Reagents are removed from the refrigerator and placed directly on the instrument. The Dimension[®] System will read the information on the bar code label and then move the cartridge into the reagent tray. It is not necessary to warm reagents to room temperature or to combine any reagents. There is no manual pre-treatment by the operator.

4. Other features shall include; auto repeat of panic values (with values that Hospital can set into the system), and auto dilution of elevated results (Hospital can choose the dilution factor).

Siemens meets this requirement.

The Dimension RxL Max with HM System can be programmed by the laboratory to automatically repeat any Panic Value reported – and the laboratory can program their desired Panic levels. The Dimension RxL Max with the HM System can be programmed by the laboratory to automatically dilute elevated results – which the laboratory can program the result level to be diluted along with the dilution factor.

The Dimension[®] RxL Max[®] with HM System can be configured to each individual laboratory's specifications to perform reflex testing. Reflex testing improves the timeliness of results because the instrument automatically performs the next test needed without having to wait for the physician to see the initial result and ask for the next test.

The Sample Alert feature tells the technologist when a sample has a test that is being rerun for one of the user configurable features. These user configurable features are auto dilute, panic repeat or reflex testing. The panic repeat notification would let them know of critical test results that were programmed as panic repeats.

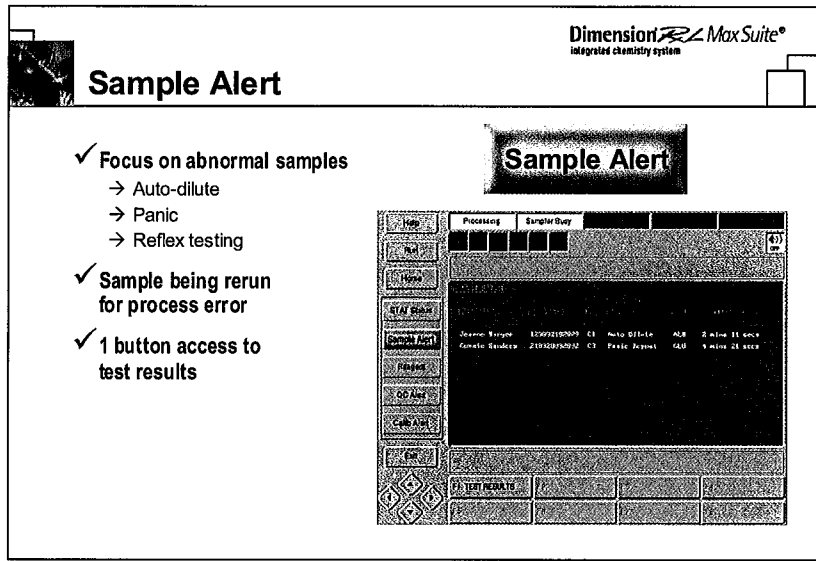

Figure 4: Sample Alert Features and Screen

5. The vendor shall ensure that a local engineer/technician is available to provide service within 12 hours of receiving a service call, within 24 hours on nights, weekends, and holidays. Technical support shall be available via telephone 24 hours a day/7 days a week to troubleshoot problems and/or answer staff questions.

Siemens meets this requirement.

Siemens shall guarantee an average emergency on-site response time from time of Technical Solutions Center notification, in other words – from the time Siemens is called -- of **12 hours or less** during normal business hours and 24 hours or less during all other hours of operation, including nights, weekends and holidays.

Phone response time is one hour or less. Normal business hours are from 8:00 a.m. to 5:00 p.m. Monday through Friday, excluding holidays. "Emergency" shall be defined as the state existing when the equipment is "down" and unavailable for quality patient testing and there is no alternative method available for running the tests. Regular repair response times shall be on-site the following business day from notification.

Strong Local Service Representation

Siemens' local Field Service Engineer is Mark Canada, located in Pineville, WV, just 40 minutes away via Route 16. In addition, Mark's back-up is located in Beckley, WV, only 1.5 hours away from Welch Community Hospital.

The 24/7 Technical Solutions Center

Siemens also provides a 24/7 Technical Solutions Center (TSC) staffed with medical technologists and engineers. Our highly skilled consultants specialize in both electromechanical and clinical chemistry troubleshooting of reagents and instrumentation.

The Technical Solutions Center (TSC) phone number is 1-800-441-9250.

Prices provided in this proposal include one year of warranty service, and four (4) years of post-warranty service in the form of the Siemens 24 Plus Service Agreement:

24 Plus Agreement: An agreement that includes preventive maintenance visits at the manufacturer's recommended intervals (if applicable) scheduled during normal business hours, unlimited service visits (labor and travel), and all necessary replacement parts, excluding

SIEMENS

WEH90053 Blanket Contract for Reagents/Consumables for use in Two Chemistry Analyzers.

disposables and customer maintenance and operating supplies, twenty-four hours per day, seven days per week.

The TSC supports Dimension® Systems in a variety of ways:

- Second Level Support, which is comprised of people who are responsible for specific methods and for monitoring method performance.*
- Technical Application Specialists (TAS) are available in the field to consult on method issues. Siemens manufactures its own reagents and this provides a higher degree of control when troubleshooting performance.*
- Field Service is available to address any instrument involvement.*

6. Test kits are to be shipped as requested. Reagents are to be shipped within six (6) days of receiving an order.

Siemens meets this requirement.

*The option of ordering reagents online is available, and it is easy with Siemens:
www.siemens.com/diagnostics*

7. Test kits must have a minimum shelf life of ninety (90) days or more beyond date of receipt. Vendor shall ensure that each of the reagents delivered to the hospital, have the maximum shelf life available for that specific product.

Siemens meets this requirement.

Siemens guarantees a minimum three month outdate from date of shipment for all our products. Typical outdates are over 1 year.

8. The number of tests requested is for bidding purposes only. The vendor will be required to provide actual quantities needed, be it more or less.

Siemens meets this requirement.

Siemens will supply the required materials needed for actual quantities.

9. Reagents shall not have to be mixed before using and be immediately ready to put on the analyzer. Reagents must not need to be frozen or reconstituted-they must be ready to use out of the refrigerator.

Siemens meets this requirement.

No manual reagent preparation required by the operator for any of the Dimension® System methods. Reagents do not require mixing before being used.

- 100% of all reagents are stored in the refrigerator*
- Reagents are placed directly on the system*
- No reagent needs to equilibrate to room temperature*
- No reagent needs to be transferred into other compartments*
- No reagent needs to be reconstituted prior to utilization*
- There are NO reagent methods that require any manual pretreatment of sample*
- No recapping, no uncapping, and no bubble checks are required by the operator*
- All reagents for any method are contained in a single cartridge*

10. All products and equipment are to be quoted FOB Destination, unless otherwise stated in vendor's quotation.

Siemens meets this requirement.

Siemens agrees. Prices presented here include instrument shipping, FOB destination, freight

All information provided in this RFQ response is proprietary and is not to be disclosed to a third party without express written permission from Siemens Healthcare Diagnostics, except as detailed herein.

SIEMENS

WEH90053 Blanket Contract for Reagents/Consumables for use in Two Chemistry Analyzers.

pre-paid and absorbed by Siemens.

Welch currently enjoys one standard reagent and consumables shipment per month at no charge. Siemens is now able to extend this enhanced offer as follows:

Prices included in this proposal include shipping and freight for up to two (2) standard reagent and consumable orders each month during this Agreement.

Beyond the first two standard shipments per month, reagent and consumable shipping will be in accordance with our current standard Shipping & Freight policy, attached here as Exhibit 2 for your convenience.

11. Vendor will deliver equipment within 30 days after the receipt of the Purchase Order and must install equipment upon delivery to the Laboratory Department.

Siemens meets this requirement.

Siemens' standard lead-time for Dimension instruments is 30 days. Siemens will work with Welch Community Hospital to schedule a mutually agreeable delivery and installation schedule.

12. Vendor will provide on-site training to Laboratory personnel. On site training will need to take place upon delivery and set up of the equipment: Vendor will need to make arrangements with the Laboratory Department for delivery date and time. The vendor will ensure hospital's laboratory staff receives on site in-service training whenever there are updates made to the equipment.

Siemens meets this requirement.

Customer Site Training

The Siemens training organization will provide onsite training for the operators who will have the responsibility for processing samples and maintaining the instrument. This training will begin when the instrument is installed and set up and continue until the Go Live date, or other mutually agreed upon timeframe, and will be at least 6 hours in length. The training group will work closely with the laboratory staff to set up a mutually agreed upon time for this training, and for the delivery date and time.

Training checklists will be provided to document training activities.

In addition to the formal onsite training, the TAS will provide ongoing training to your staff operators whenever there are updates to the equipment.

Online System Education Opportunities

Siemens is pleased to offer the Online Education interactive e-learning programs for our customers. Online Education brings a virtual classroom right to your lab, providing a convenient and cost effective way to move staff up the learning curve quickly and manage long-term knowledge development.

Customers may register for the classes by visiting www.siemens.com/diagnostics, click on Education, then on Online Education.

Classes include topics for Automation, Certification, Chemistry, Immunochemistry, Hemostasis, Hematology, Information Systems, Microbiology, Urinalysis, and Virtual Classroom.

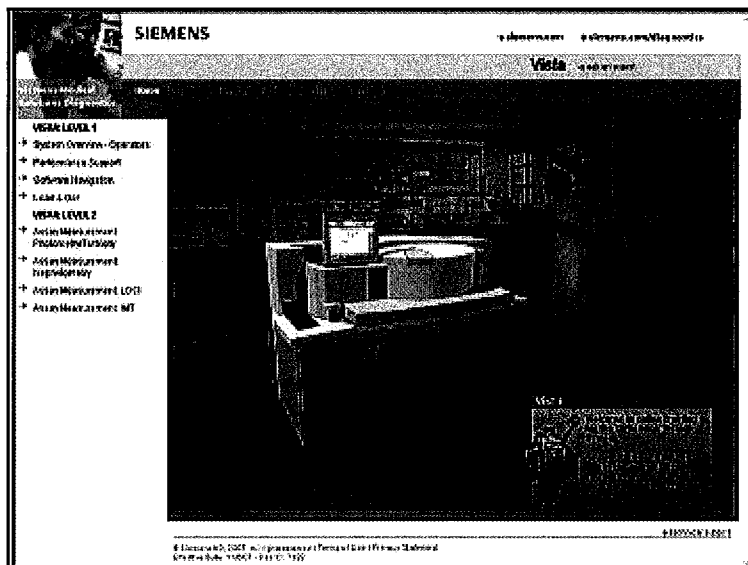

Figure 5: Example: snapshot of Online Education for Dimension Vista®

Multiple applications exist for Online Education programs:

- *Pre-training preparation for those attending Siemens Off-Site Key Operator Training*
- *Classroom attendees can use Online Education programs to share educational materials and information provide training with other staff members*
- *A quick reference and refresher tool*

Using the Siemens Online Education resources, staff can acquire online a baseline understanding of the components and basics of operation for Siemens instruments online and prior to attending hands-on off-site Siemens instrument training. The formal classroom training then supplements and strengthens the student's pre-training knowledge base. Attendees are better prepared, which means a reduced learning curve, less time spent in the classroom and more take-home knowledge. Additionally, students will be equipped with the skills to share educational materials and information with personnel back in the lab.

Online Education programs are always ready and available to all techs 365 days per year. The training offers employees the flexibility to complete the course at his/her own pace and as schedules allow. The program automatically bookmarks the last segment completed so that users can easily pick up where they left off to continue training.

Term of Contract & Renewals:

This contract will be effective (date set upon award) and shall extend for the period of one (1) year, at which time the contract may, upon mutual consent, be renewed. Such renewals are for a period of up to one (1) year, with a maximum of four (4) one year renewals, or until such reasonable time thereafter as is necessary to obtain a new contract. The "reasonable time" period shall not exceed twelve (12) months. During the "reasonable time" period the Vendor may terminate the contract for any reason upon giving the Agency ninety (90) days written notice. Notice by Vendor of intent to terminate will not relieve Vendor of the obligation to continue to provide services pursuant to the terms of the contract.

Siemens agrees.

SIEMENS

WEH90053 Blanket Contract for Reagents/Consumables for use in Two Chemistry Analyzers.

Any change in Federal or State law, or court actions which constitute binding precedent in West Virginia, and which significantly alters the Vendor's required activities or any change in the availability of funds, shall be viewed as binding and shall warrant good faith renegotiation of the compensation paid to the Vendor by the Agency and of such other provisions of the contract that are affected. If such renegotiation proves unsuccessful, the contract may be terminated by the State upon written notice to the Vendor at least thirty (30) days prior to termination of this contract.

Siemens agrees.

Non-Appropriation of Funds:

If the Agency is not allotted funds in any succeeding fiscal year for the continued use of the service covered by this contract by the West Virginia Legislature, the Agency may terminate the contract at the end of the affected current fiscal period without further charge or penalty. The Agency shall give the vendor written notice of such non-allocation of funds as soon as possible after the Agency receives notice. No penalty shall accrue to the Agency in the event this provision is exercised.

Siemens agrees.

Contract Termination:

The State may terminate any contract immediately at any time the Vendor fails to carry out its responsibilities or to make substantial progress under the terms of this contract. The State shall provide the Vendor with advance notice of performance conditions which are endangering the contract's continuation. If after such notice the Vendor fails to remedy the conditions contained in the notice, within the time period contained in the notice, the State shall issue the Vendor an order to cease and desist any and all work immediately. The State shall be obligated only for services rendered and accepted prior to the date of the notice of termination. The contract may also be terminated by the State with thirty (30) days prior notice.

Siemens agrees.

Changes:

If changes to the original contract become necessary, a formal contract change order will be negotiated by the State, the Agency and the Vendor, to address changes to the terms and conditions, costs of work included under the contract. An approved contract change order is defined as one approved by the Purchasing Division and approved as to form by the West Virginia Attorney General's Office, encumbered and placed in the U.S. Mail prior to the effective date of such amendment. An approved contract change order is required whenever the change affects the payment provision or the scope of the work. Such changes may be necessitated by new and amended Federal and State regulations and requirements.

As soon as possible after receipt of a written change request from the Agency, but in no event more than thirty (30) days thereafter, the Vendor shall determine if there is an impact on price with the change requested and provide the Agency a written statement to identifying any price impact on the contract or to state that there is no impact. In the event that price will be impacted by the change, the Vendor shall provide a description of the price increase or decrease involved in implementing the requested change.

NO CHANGE SHALL BE IMPLEMENTED BY THE VENDOR UNTIL SUCH TIME AS THE VENDOR RECEIVES AN APPROVED WRITTEN CHANGE ORDER.

Siemens agrees.

Invoices:

The Vendor shall submit invoices, in arrears, to the Agency at the address on the face of the purchase order labeled "Invoice To" pursuant to the terms of the contract.

Siemens agrees.

SIEMENS

WEH90053 Blanket Contract for Reagents/Consumables for use in Two Chemistry Analyzers.

Cost Evaluation:

Bid Response must include the cost for each lab test as well as the cost for the consumables that may be purchased throughout the term of the contract. It shall be understood that the quantities are estimates based on previous activity and are not binding. Supplies shall be provided as ordered regardless of the actual quantities ordered, whether more or less.

Evaluation will be based on the overall lowest price of each lab test and the estimated annual usage of consumables.

It is preferred that each responder use the Cost Proposal Sheet provided.

Siemens agrees to use the Cost Proposal Sheet provided. Please see the attached Price Exhibit titled "Bid Sheet."

SIEMENS

WEH90053 Blanket Contract for Reagents/Consumables for use in Two Chemistry Analyzers.

The following tests methods are to be performed on one fully automated analyzer. (Dade RxL Max Systems or equal)

Siemens meets this requirement.

The Siemens Dimension® RxL Max® with HM performs all of the following tests by using the methodology listed below.

General Chemistry

Albumin
Calcium
Cholesterol
Creatnine
Direct Bilirubin
Enzymatic Carbonate
Glucose (GLU)
Glucose Gluc (Liquid)
High-Density Lipoprotein Cholesterol
Automated HDL Cholesterol

Iron
Automated LDL
Magnesium
Phosphorus
Total Bilirubin
Total Iron-Binding Capacity
IBCT (No Pre-treat)
Total Protein
Triglycerides
Urea Nitrogen
Uric Acid

Electrolytes

Carbon Dioxide
Chloride
Potassium
Sodium

Endocrinology

*Currently, the hospital uses Dade Behring equipment, thus, some test methods are unique and proprietary to the equipment/company. Please provide your proposed test method that may be specific to the equipment that may be proposed in your bid response.

Hemoglobin A1C
Thyronine Uptake
Total Thyroxine
Triiodothyronine

TEST Method

Dye Binding-Bromcresol Purple
Cresolphthalein complexone
Enzymatic
Kinestic Alkaline Picrate (Jaffe)
Diazo-Caffeine/Benzoate Coupling
Enzymatic
Hexokinase
Hexokinase
Non-Pretreat Accelerated Cholesterol Oxidase
Phophotungstic Acit/No metal ions w Enzymatic
Quantitation
Ferene without prior protein removal
Liquid Selective Detergent
Colorimetric Dye Methylthymol Blue
Phosphomolybdate-UV
Diazo-Caffeine/Benzoate Coupling
Alumina Adsorption
Ferene
Biuret
Enzymatic 340nm without serum blank GPDH
Urease with GLDH (Coupled Enzymes)
Uricase

TEST Method

Enzymatic
Ion Selective Electrode, Indirect
Ion Selective Electrode, Indirect
Ion Selective Electrode, Indirect

TEST Method

*see above
*see above
*see above
*see above

Enzymes

*Currently, the hospital uses Dade Behring equipment, thus, some test methods are unique and proprietary to the equipment/company. Please provide your proposed test method that may be specific to the equipment that may be proposed in your bid response.

TEST Method

All information provided in this RFQ response is proprietary and is not to be disclosed to a third party without express written permission from Siemens Healthcare Diagnostics, except as detailed herein.

SIEMENS

WEH90053 Blanket Contract for Reagents/Consumables for use in Two Chemistry Analyzers.

Acid Phosphatase	Adapted Thymolphtholein
Alanine Aminotransferase	Monophosphate hydrolysis
Alkaline Phosphatase Adapted	Adapted Bergmyer methodology
Amylase	Bowers and McDomb methodology
Aspartate Aminotransferase	*see above
Creatine Kinase	*see above
Creatine Kinase MB Isoenzyme	Modified, Enzymatic Oliver
Glutamyl Transferase	*see above
Lactic Dehydrogenase	*see above
Lipase	Modified Enzymatic Lactate to Pyruvate Methodology
Pseudocholinesterase	Adapted Clorimetric Neumann
	Coupled Oxidation reduction-Gal and Roth

Heterogeneous Immunoassays

TEST Method

*Currently, the hospital uses Dade Behring equipment, thus, some test methods are unique and proprietary to the equipment/company. Please provide your proposed test method that may be specific to the equipment that may be proposed in your bid response.

Cardiac Troponin	*see above
Ferritin	*see above
Free PSA	*see above
Free Thyroxine	*see above
Human Chorionic Gonadotropin Hormone	*see above
Mass CK-MB	*see above
Myoglobin	*see above
NT-proBNP	ProBNP Enzymatic Immunoassay Methodology
Thyroid Stimulating Hormone	*see above
Total PSA	*see above

Immunology

TEST Method

Complement C3, Complement C4	Turbidimetric Assay, Quantitative
C-Reactive Protein	Highly Sensitive, colorimetric Immunoassay
IGA, IGG, IGM	Quantitative, Turbidimetric Assay
Transferrin	Quantitative, Turbidimetric Assay

Specialty

TEST Method

Ammonia	Glutamate Dehydrogenase Enzymatic Method
Urine-Cerebrospinal Fluid Protein	Pyrogallol Red-molybdate Method
Lactic Acid	
Microalbumin	PETINIA** adapted methodology
Prealbumin	PETINIA technology method

Therapeutic Drug Monitoring

TEST Method

*Currently, the hospital uses Dade Behring equipment, thus, some test methods are unique and proprietary to the equipment/company. Please provide your proposed test method that may be specific to the equipment that may be proposed in your bid response.

Carbamazepine	PETINIA immunoassay methodology
Cyclosporine	*see above
Digoxin	*see above

All information provided in this RFQ response is proprietary and is not to be disclosed to a third party without express written permission from Siemens Healthcare Diagnostics, except as detailed herein.

SIEMENS

WEH90053 Blanket Contract for Reagents/Consumables for use in Two Chemistry Analyzers.

Digitoxin	*see above
Gentamicin	Enhanced turbidimetric PETINIA
Lidocaine	*see above
Lithium	Non-covalent binary complex methodology
N-Acetylprocainamide	PETINIA methodology
Phenobarbital	PETINIA methodology
Phenytoin	PETINIA methodology
Procainamide	PETINIA methodology
Sirolimus	*see above
Tacrolimus	*see above
Theophylline	PETINIA methodology
Tobramycin	PETINIA methodology
Vancomycin	PETINIA methodology
Valproic Acid	PETINIA methodology

Toxicology

Acetaminophen
Ethyl Alcohol
Salicylate
Urine Amphetamine Screen
Urine Barbiturates Screen
Urine Benzodiazepines Screen
Urine Cannabinoids Screen
Urine Cocaine Metabolite Screen
Urine Methadone Screen
Urine Opiates Screen
Urine Phencyclidine Screen

TEST Method

Enzymatic hydrolysis methodology
Modified alcohol dehydrogenase methodology
Modified Trinder colorimetric
Syva Emit II Plus methodology
Syva Emit II Plus methodology
Syva Emit II Plus methodology
Syva Emit II Plus methodology
Syva Emit II Plus methodology
Syva Emit II Plus methodology
Syva Emit II Plus methodology
Syva Emit II Plus methodology

**PETINIA = particle enhanced turbidimetric inhibition immunoassay

SIEMENS

WEH90053 Blanket Contract for Reagents/Consumables for use in Two Chemistry Analyzers.

OPERATING ENVIRONMENT

Location

Facility is located in McDowell County at Welch Community Hospital, 454 McDowell Street, Welch WV 24801

Background:

Welch Community Hospital is a 124 bed hospital, 59 of which are Long Term care beds. Acute care beds include: 8 Intensive care beds; 2 pediatric beds; 10 obstetrical beds and 45 medical/surgical beds. The hospital serves the counties of McDowell, Wyoming and Mingo with a total market population of about 83,000.

The following numbers represent the typical utilization encountered by the outpatient service area of Welch Community Hospital for the 2007 fiscal year:

Emergency Room Patients - 10,441

Observation Visits - 542

Clinic Patients - 25,524

Surgeries - 343

Deliveries -- 78

Laboratory Tests - 771,015

Radiology - 15,063

CAT Scans - 2,529

Ultrasound - 1,869

Mammography - 633

Respiratory Tests - 21,402

Electrocardiograms - 4,231

Admissions -- 974

Long Term Card ADC (48 Patients per

day) - 94% Overall ADC (60 Patients per

day) - 66%

Total Patient Days (17,514 Long Term Care and 4,496 Acute Care Days) - 22,010

Outpatient Services Provided Are:

Primary Care and Family Practice in a Certified Rural Health Setting

Pediatric Clinic

Newborn Care

Internal Medicine

Surgery

Emergency Room Services

Radiology Services Including:

Diagnostic

CAT Scan

Ultrasound

Mammography

MRI

EKG, Cardiac Doppler Studies, Stress Testing and Respiratory Therapy

Services Laboratory Services

Siemens Acknowledges receipt of this information.

All information provided in this RFQ response is proprietary and is not to be disclosed to a third party without express written permission from Siemens Healthcare Diagnostics, except as detailed herein.

SCIENTIS

WEH90053 Blanket Contract for Reagents/Consumables for use in Two Chemistry Analyzers. Bid/Price Sheet

Item No.	Estimated Annual Usage	Description	Unit #	Count Per Unit	Unit Price	Estimated Annual Cost
1	26 units	ALB-Albumin	DF13	480 test per unit	\$ 0.198	\$ 2,471.04
2	36 units	BUN-Urea Nitrogen	DF21	480 test per unit	\$ 0.198	\$ 3,421.44
3	34 units	CA-Calcium	DF23A	480 test per unit	\$ 0.198	\$ 3,231.36
4	10 units	CHOL-Cholesterol	DF27	480 test per unit	\$ 0.206	\$ 988.80
5	40 units	CREA-Creatinine	DF33A	480 test per unit	\$ 0.198	\$ 3,801.60
6	30 units	ECCO2-Enzymatic CO2	DF137	360 test per unit	\$ 0.198	\$ 2,138.40
7	20 units	GLU-Glucose	DF40 (DF 39A)	960 test per unit	\$ 0.198	\$ 3801.60
8	10 units	PHOS-Phosphorus	DF61	480 test per unit	\$ 0.206	\$ 988.80
9	46 units	TBIL-Total Bilirubin	DF67A (DF 167)	480 test per unit	\$ 0.198	\$ 4,371.04
10	34 units	TPROT-Total Protein	DF73	480 test per unit	\$ 0.198	\$ 3,231.36
11	10 units	URCA-Uric Acid	DF77	480 test per unit	\$ 0.206	\$ 988.80
12	50 units	ALP-Alkaline Phosphatase	DF15A	360 test per unit	\$ 0.198	\$ 3,564.00
13	10 units	CK-Creatinine Kinase	DF29A	480 test per unit	\$ 0.206	\$ 988.80
14	14 units	DBIL-Direct Bilirubin	DF25A (DF 125)	320 test per unit	\$ 0.206	\$ 922.88
15	12 units	GGT-Gamma Glutamyl Transferase	DF45A	288 test per unit	\$ 0.206	\$ 711.96
16	52 units	AST-Aspartate Aminotransferase	DF41A	360 test per unit	\$ 0.198	\$ 3,706.56
17	72 units	ALT-Alanine Aminotransferase	DF43A	240 test per unit	\$ 0.198	\$ 3,421.44
18	18 units	LDH-Lactic Dehydrogenase	DF53A	480 test per unit	\$ 0.206	\$ 1,779.84
19	17 units	TGL-Triglyceride	DF69A	480 test per unit	\$ 0.206	\$ 1,680.96
20	10 units	ACTM-Acetaminophen	DF88	80 test per unit	\$ 0.909	\$ 727.20

DF40
QUOTED AS
LINE # 97,
SEE BELOW

NEW UNIT #,
SEE BELOW

NEW UNIT #,
SEE BELOW

S MENS

WEH90053 Blanket Contract for Reagents/Consumables for use in Two Chemistry Analyzers. Bid/Price Sheet

Item No.	Estimated Annual Usage	Description	Unit #	Count Per Unit	Unit Price	Estimated Annual Cost
21	19 units	ALC-Alcohol	DF18 (DF)	120 test per unit	\$ 0.909	\$ 2,072.52
22	10 units	AMON-Ammonia	DF19	120 test per unit	\$ 0.909	\$ 1,090.80
23	16 units	AMY-Amylase	DF17A	240 test per unit	\$ 0.652	\$ 2,503.68
24	12 units	CRP-C Reactive Protein	DF37	120 test per unit	\$ 0.909	\$ 1,308.96
25	8 units	IRN-Iron	DF49A (DF)	240 test per unit	\$ 0.909	\$ 1,745.28
26	28 units	LIP-Lipase	DF55A	120 test per unit	\$ 0.909	\$ 3,054.24
27	28 units	MG-Magnesium	DF57	120 test per unit	\$ 0.652	\$ 2,190.72
28	10 units	SAL-Salicylate	DF20	120 test per unit	\$ 0.909	\$ 1,090.80
29	16 units	TU-Thyronine Uptake	DF75A	160 test per unit	\$ 0.909	\$ 2,327.04
30	26 units	T4-Thyroxine	DF65	120 test per unit	\$ 0.909	\$ 2,836.08
31	6 units	UCFP-Urine CF Protein	DF26	80 test per unit	\$ 0.909	\$ 436.32
32	14 units	CREM-Carbamazepine	DF87	80 test per unit	\$ 1.589	\$ 1,779.68
33	36 units	DGNA-Digoxin No Pretreat	DF35A	80 test per unit	\$ 1.589	\$ 4,576.32
34	31 units	GENT-Geutamicin	DF12	80 test per unit	\$ 1.589	\$ 3,940.72
35	32 units	PHNO-Phenobarbital	DF60	80 test per unit	\$ 1.589	\$ 4,067.84
36	26 units	PTN-Phenytoin	DF64	112 test per unit	\$ 1.589	\$ 4,627.22
37	28 units	THEO-Theophylline	DF71	80 test per unit	\$ 1.589	\$ 3,559.36
38	16 units	VALP-Valproic Acid	DF78	80 test per unit	\$ 1.589	\$ 2,033.92
39	10 units	VANC-Vancomycin	DF86	80 test per unit	\$ 1.589	\$ 1,271.20
40	14 units	FERR-Ferritin	RF440	120 test per unit	\$ 1.806	\$ 3,034.08

NEW UNIT #
SEE NOTE 6e

NEW UNIT #,
SEE NOTE 6e

*

*

SILVENS

WEH90053 Blanket Contract for Reagents/Consumables for use in Two Chemistry Analyzers. Bid/Price Sheet

Item No.	Estimated Annual Usage	Description	Unit #	Count Per Unit	Unit Price	Estimated Annual Cost
41	18 units	HCG-Human Chorionic Gonadotrophin	RF430	120 test per unit	\$ 1.857	\$ 4,011.12
42	40 units	MMB-Mass CKMB	RF420	160 test per unit	\$ 1.699	\$ 10,873.60
43	10 units	TPSA-Revised Prostate Specific Antigen	RF451	120 test per unit	\$ 3.402	\$ 4,082.40
44	20 units	TSH-Thyroid Stimulating Hormone	RF412	200 test per unit	\$ 1.394	\$ 5,576.00
45	62 units	CTnl-Tropoin I	RF421C	120 test per unit	\$ 3.076	\$ 22,885.44
46	16 units	AHDL-HDL Cholesterol, Automated	DF48A	240 test per unit	\$ 0.652	\$ 2,503.68
47	8 units	IBCT-Iron Binding	DF84	240 test per unit	\$ 0.909	\$ 1,745.28
48	8 units	TRNF-Transferrin	DF103	120 test per unit	\$ 2.115	\$ 2,030.40
49	8 units	AHDL Calibrator	DC48A	2 sets/5 levels unit	\$ 28.460	\$ 227.68
50	6 units	ALC Calibrator	DC37 (37A)	2 sets/4 levels per unit	\$ 28.590	\$ 171.54
51	6 units	AMON Calibrator	DC25	2 sets/3 levels per unit	\$ 28.460	\$ 170.76
52	16 units	CHEM I Calibrator	DC18A	2 sets/3 levels per unit	\$ 38.750	\$ 620.00
53	10 units	CHEM II Calibrator	DC20	2 sets/3 levels per unit	\$ 44.630	\$ 446.30
54	6 units	CHOL Calibrator	DC16	2 sets/3 levels per unit	\$ 28.460	\$ 170.76
55	4 units	CK Verifier	DC26	2 sets/3 levels per unit	\$ 44.630	\$ 178.52
56	6 units	CRP Calibrator	DC30	2 sets/3 levels per unit	\$ 61.160	\$ 366.96
57	12 units	DRUG II Calibrator	DC49D	2 sets/5 levels per unit	\$ 165.630	\$ 1,987.56
58	8 units	ECO2 Calibrator	DC137	2 sets/3 levels per unit	\$ 33.760	\$ 270.08
59	8 units	Enzyme Verifier	DC19	2 sets/3 levels per unit	\$ 67.610	\$ 540.88
60	6 units	FERR Calibrator	RC440	2 sets/5 levels per unit	\$ 48.220	\$ 289.32

New Unit #,
See Note Below

*

SIEMENS

WEH90053 Blanket Contract for Reagents/Consumables for use in Two Chemistry Analyzers. Bid/Price Sheet

Item No.	Estimated Annual Usage	Description	Unit #	Count Per Unit	Unit Price	Estimated Annual Cost
61	6 units	HCG Calibrator	RC430	2 sets/5 levels per unit	\$ 43.860	\$ 263.16
62	6 units	IBCT Calibrator	DC84	2 sets/3 levels per unit	\$ 33.140	\$ 198.84
63	4 units	IRN/TIBC Calibrator	DC21 (DC 85)	2 sets/3 levels per unit	\$ 27.520	\$ 110.08
64	6 units	Lipase Verifer	DC15A	2 sets/3 levels per unit	\$ 50.690	\$ 304.12
65	8 units	MMB Calibrator	RC420	2 sets/5 levels per unit	\$ 54.790	\$ 438.32
66	12 units	REV Drug Calibrator	DC22B	2 sets/5 levels per unit	\$ 166.200	\$ 1,994.40
67	6 units	SAL Calibrator	DC38	2 sets/3 levels per unit	\$ 34.330	\$ 205.98
68	6 units	Special Protein Calibrator	DC51	2 sets/5 levels per unit	\$ 59.660	\$ 357.96
69	6 units	T4 Calibrator	DC13	2 sets/5 levels per unit	\$ 56.050	\$ 336.30
70	6 units	TBIL/DBIL Calibrator	DC17 (DC 167)	2 sets/3 levels per unit	\$ 53.960	\$ 323.76
71	6 units	TP/ALB Calibrator	DC31	2 sets/3 levels per unit	\$ 39.250	\$ 235.50
72	4 units	T/FPFA Calibrator	RC452	2 sets/5 levels per unit	\$ 71.530	\$ 286.12
73	6 units	TU Calibrator	DC14	2 sets/5 levels per unit	\$ 60.780	\$ 364.68
74	6 units	Thyroid Calibrator	RC410	2 sets/5 levels per unit	\$ 82.180	\$ 493.08
75	6 units	UCFP Calibrator	DC45	2 sets/5 levels per unit	\$ 35.660	\$ 213.96
76	12 units	cTnl Calibrator	RC421C	2 sets/5 levels per unit	\$ 54.790	\$ 657.48
77	134 units	ABS Absorbance Test	DF79	120 test per unit	\$ 27.520	\$ 3,687.68
78	83 units	Cuvette Cartridge	D828	12,000 test per unit	\$ 185.400	\$ 15,388.20
79	4 units	Enzyme Diluent	ED	10 bble/10 ml per unit	\$ 44.170	\$ 176.68
80	24 units	Printer Paper -RXL	D829	6 rolls/80ft per unit	\$ 75.060	\$ 1,801.44

NEW UNIT #
See Note B e1

NEW UNIT #
See Note B e

*

*

SIEMENS

WEH90053 Blanket Contract for Reagents/Consumables for use in Two Chemistry Analyzers. Bid/Price Sheet

Item No.	Estimated Annual Usage	Description	Unit #	Count Per Unit	Unit Price	Estimated Annual Cost
81	4 units	Sample Diluent-SD Plus	SDPlus	2 btle/50 ml per unit	\$ 26.130	\$ 104.52
82	15 units	Small Sample Cups	DSC5	1,000 test per unit	\$ 35.530	\$ 532.95
83	2 units	Sample Cups with Lids	DSC4	1,000 test per unit	\$ 22.400	\$ 44.80
84	26 units	Chem Wash	RD701	1btl/1800 ml per unit	\$ 24.240	\$ 630.24
85	4 units	IMT Probe Cleaner	RD704	12btles per unit	\$ 25.180	\$ 100.72
86	62 units	Reagent Probe Cleaner	RD702	1 btl/500 ml per unit	\$ 14.010	\$ 868.62
87	26 units	Rev Heterogenous Mod Vessels	RXV1A	1,000 test per unit	\$ 32.890	\$ 855.14
88	16 units	Sample Probe Cleaner	RD703	1 btl/1000 ml per unit	\$ 18.610	\$ 297.76
89	8 units	QuickLYTE Dilution Check	S640	3 bags/1000 ml per unit	\$ 17.920	\$ 143.36
90	8 units	QuickLYTE Flush Solution	S630	3 bags/1000 ml per unit	\$ 145.060	\$ 1,160.48
91	38 units	QuickLYTE IMT Cartridge	S600	4 cartridges per unit	\$ 151.630	\$ 5,761.94
92	20 units	QuickLYTE Sample Diluent	S635	1 btl/500 ml per unit	\$ 70.690	\$ 1,413.80
93	23 units	QuickLYTE Standard A	S620	3 bags/1000 ml per unit	\$ 145.060	\$ 3,336.38
94	14 units	QuickLYTE Standard B	S625	3 bags/1000 ml per unit	\$ 145.060	\$ 2,030.84
95	12 units	Salt Bridge Solution	D105	3 btle/150 ml per unit	\$ 38.950	\$ 467.40
96	6 units	Reagent Probe Tip	715871.505	48000 test per unit	\$ 0.00	\$ 0.00
97	12 units	GLUC - Liquid Glucose	DF40	1440 test per unit	\$ 0.198	\$ 3,421.44
98	6 units	LI - Lithium	DF132	80 test per unit	\$ 1.589	\$ 762.72
99	4 units	FT4 - Free T4	RR410	120 test per unit	\$ 1.497	\$ 718.56

PLEASE SEE NOTES AT LINE #7 AND BELOW.

*

SIEMENS

WEH90053 Blanket Contract for Reagents/Consumables for use in Two Chemistry Analyzers. Bid/Price Sheet

Item No.	Estimated Annual Usage	Description	Unit #	Count Per Unit	Unit Price	Estimated Annual Cost
100	32 units	ALDL - Automated LDL Cholesterol	DF131	120 test per unit	\$2.681	\$10,295.04
101	12 units	ALDL Calibrator	DC131	2 sets/5 levels per unit	\$59.510	\$714.12
Total Estimated Annual Cost for the Reagents/Consumables =						\$217,132.31
Price Per Lab Test Procedure Performed \$						x Estimated Quantity 100,000 = Total
Total of Reagents/Consumables + Total of Lab Test Costs =						\$217,132.31

Please attach your vendor references. SIEMENS AGREES. VENDOR SEE ATTACHED REFERENCES.

Two (2) new chemistry analyzers: (Date Rxl Max Systems or equal.)

Brand Name/Model: DIMENSION[®] Rxl MAX[®] SYSTEMS WITH H.M. (2)

List of Components/Accessories: INCLUDED IN PRICES ABOVE: ONE (1) MULTIPROBE WATER SYSTEM
Two (2) New DIMENSION Rxl MAX with H.M. Systems,

PRICE ADJUSTMENT PROVISION:

THE STATE OF WEST VIRGINIA WILL CONSIDER BIDS THAT CONTAIN PROVISIONS FOR PRICE ADJUSTMENTS PRIOR TO THE ORIGINAL EXPIRATION OF THE CONTRACT, PROVIDED THAT SUCH PRICE ADJUSTMENT COVERS BOTH UPWARD AND DOWNWARD MOVEMENT OF THE COMMODITY PRICE, AND THAT ADJUSTMENT IS BASED ON THE "PASS THROUGH" INCREASE OR DECREASE OF RAW MATERIALS AND/OR LABOR, WHICH MAKE UP ALL OR A SUBSTANTIAL PART OF A PRODUCT. ADJUSTMENTS ARE TO BE BASED UPON AN ACTUAL DOLLAR FIGURE, NOT A PERCENTAGE.

ALL PRICE ADJUSTMENT REQUESTS MUST BE SUBSTANTIATED IN A MANNER ACCEPTABLE TO THE DIRECTOR PURCHASING, E.G. GOVERNMENTAL BENCH MARKS, GENERAL MARKET INCREASE, PUBLISHED PRICE LISTS. SUCH REQUESTS FOR AND INCREASE SHOULD BE RECEIVED IN WRITING BY THE DIRECTOR OF PURCHASING AT LEAST 30 DAYS IN ADVANCE OF THE EFFECTIVE DATE OF THE INCREASE. ANY TIME THE VENDOR REQUESTS A PRICE ADJUSTMENT, THE PURCHASING DIVISION MAY EITHER ACCEPT THE PRICE ADJUSTMENT AND AMEND THE CONTRACT ACCORDINGLY OR REJECT THE ADJUSTMENT IN ITS ENTIRETY AND CANCEL THE CONTRACT.

PREFERRED TERMS:

IT IS PREFERRED THAT THE PRICES ON THIS CONTRACT ARE FIRM FOR LIFE OF THE CONTRACT, AS INDICATED IN THE LIFE OF CONTRACT CLAUSE CONTAINED HEREIN, NOT TO EXCEED ONE (1) YEAR. SIEMENS AGREES.

SIEMENS

IF THE VENDOR CANNOT GUARANTEE A FIRM PRICE FOR THE LIFE OF CONTRACT, HE MUST INDICATE ONE OF THE PARAGRAPHS LISTED BELOW. FAILURE TO QUALIFY THE PREFERRED TERMS WILL BIND THE VENDOR TO A FIRM PRICE FOR THE LIFE OF THE CONTRACT.

ALTERNATE TERMS: (NOT APPLICABLE)

- () THE PRICES ON THIS CONTRACT WILL REMAIN FIRM FOR DAYS AFTER THE EFFECTIVE DATE OF THE CONTRACT. PRICES WILL REMAIN FIRM AFTER EACH PRICE ADJUSTMENT FOR A MINIMUM OF DAYS.
- () THE VENDOR DOES NOT AGREE TO MAINTAIN A FIRM PRICE FOR THE LENGTH OF THE CONTRACT BUT OFFERS AN ALTERNATE PROPOSAL AS FOLLOWS:

* BID/PRICE SHEET NOTES: 960 test per unit - this is unit # DF39A
 ITEM 7) GLU - Line 7 Requesting 960 test per unit - this is unit # DF39A
 GLU - 1440 test/unit has unit # of DF40, QUOTED HERE AS LINE ITEM #97, as requested

ITEM 9) TBIL - REVISED WITH NEW UNIT # OF DF167 - SAME COUNT PER UNIT
 ITEM 14) DBIL - REVISED WITH NEW UNIT # OF DF125 - SAME COUNT PER UNIT
 ITEM 21) ALC - REVISED WITH NEW UNIT # OF DF22 - SAME COUNT PER UNIT
 ITEM 25) IRN - REVISED WITH NEW UNIT # OF DF85 - SAME COUNT PER UNIT
 ITEM 50) ALC - REVISED WITH NEW UNIT # OF DC37A - SAME COUNT PER UNIT.
 ITEM 63) IRN/TIBC CALIBRATOR - REVISED WITH NEW UNIT # OF DC85 - SAME COUNT PER UNIT
 ITEM 70) TBIL/DBIL CALIBRATOR - REVISED WITH NEW UNIT # OF DC167 - SAME COUNT PER UNIT
 ITEM 97) PLEASE SEE NOTE FOR ITEM # 7, ABOVE. (ITEM #97 IS THE
 NEW UNIT # DF40 WITH 1440 tests PER UNIT

SIEMENS

WEH90053 Blanket Contract for Reagents/Consumables for use in Two Chemistry Analyzers.

*Welch Community Hospital
Response to RFQ# WEH90053
February 26, 2009
Exhibit 3, References*

Please also find these references in page 7 of the attached Siemens' RFQ response document, and also behind the Price Exhibit tab of this binder.

*Williamson Memorial Hospital
859 Alderson Street
Williamson, WV 25661
Kandi Justice, Lab Manager
304-235-2500 x130*

*Williamson ARH Hospital
260 Hospital Drive
South Williamson, KY 41503
LeAnn Hubbard, Laboratory Manager
606-237-1736*

*Raleigh General Hospital
1710 Harper Road
Beckley, WV 25801
Janet Halstead, Laboratory Manager
304-256-4157*



State of West Virginia
 Department of Administration
 Purchasing Division
 2019 Washington Street East
 Post Office Box 50130
 Charleston, WV 25305-0130

Request for Quotation

RFQ NUMBER
 WEH90053

PAGE
 1

ADDRESS CORRESPONDENCE TO ATTENTION OF
 ROBERTA WAGNER
 304-558-0067

*603160724 800-267-5387
 DADE BEHRING INC
 SET TO PURGE
 1717 DEERFIELD RD
 DEERFIELD IL 60015-0780

HEALTH AND HUMAN RESOURCES
 WELCH COMMUNITY HOSPITAL
 454 MCDOWELL STREET
 WELCH, WV 24801 304-436-8710

DATE PRINTED	TERMS OF SALE	SHIP VIA	F.O.B.	FREIGHT TERMS
01/28/2009				

BID OPENING DATE: 02/26/2009 BID OPENING TIME 01:30PM

LINE	QUANTITY	UOP	CAT NO	ITEM NUMBER	UNIT PRICE	AMOUNT
1	1	JB		193-12		
REAGENTS (FOR AUTOMATIC INSTRUMENTS) REQUEST FOR QUOTATION TO PROVIDE AN OPEN END CONTRACT FOR REAGENTS TO PERFORM EXAMINATION FOR DETECTION OF SPECIFIED METHODS. SELECTED VENDOR MUST PROVIDE TWO FULLY AUTOMATED CHEMISTRY ANALYZERS AT NO ADDITIONAL CHARGE FOR USE WITH THE REQUESTED REAGENTS, PER THE ATTACHED SPECIFICATIONS. THE SYSTEMS MUST INCLUDE A COMPUTER, MONITOR, AND PRINTER WHICH WILL BE RETAINED AND MAINTAINED BY THE VENDOR. THIS CONTRACT WILL BE FOR A PERIOD OF ONE YEAR WITH THE OPTION OF FOUR (4), ONE (1) YEAR RENEWALS. EXHIBIT 3						

SEE REVERSE SIDE FOR TERMS AND CONDITIONS

SIGNATURE *William R. Shreve* TELEPHONE 847-236-7280 DATE 2/20/09

TITLE VP, SALES / CUSTOMER OPS FEIN 95-2802182 ADDRESS CHANGES TO BE NOTED ABOVE

WHEN RESPONDING TO RFQ, INSERT NAME AND ADDRESS IN SPACE ABOVE LABELED 'VENDOR'



State of West Virginia
 Department of Administration
 Purchasing Division
 2019 Washington Street East
 Post Office Box 50130
 Charleston, WV 25305-0130

Request for Quotation

RFQ NUMBER
WEH90053

PAGE
2

ADDRESS CORRESPONDENCE TO ATTENTION OF
ROBERTA WAGNER
304-558-0067

VENDOR

*603160724 800-267-5387
DADE BEHRING INC
SET TO PURGE
1717 DEERFIELD RD
DEERFIELD IL 60015-0780

SHIP TO

HEALTH AND HUMAN RESOURCES
WELCH COMMUNITY HOSPITAL

454 MCDOWELL STREET
WELCH, WV
24801 304-436-8710

DATE PRINTED	TERMS OF SALE	SHIP VIA	FOB	FREIGHT TERMS
01/28/2009				

BID OPENING DATE: **02/26/2009** BID OPENING TIME **01:30PM**

LINE	QUANTITY	UOP	CAT NO	ITEM NUMBER	UNIT PRICE	AMOUNT
<p>LIFE OF CONTRACT: THIS CONTRACT BECOMES EFFECTIVE ON AWARD OF CONTRACT.. AND EXTENDS FOR A PERIOD OF ONE (1) YEAR OR UNTIL SUCH "REASONABLE TIME" THEREAFTER AS IS NECESSARY TO OBTAIN A NEW CONTRACT OR RENEW THE ORIGINAL CONTRACT. THE "REASONABLE TIME" PERIOD SHALL NOT EXCEED TWELVE (12) MONTHS. DURING THIS "REASONABLE TIME" THE VENDOR MAY TERMINATE THIS CONTRACT FOR ANY REASON UPON GIVING THE DIRECTOR OF PURCHASING 30 DAYS WRITTEN NOTICE.</p> <p>UNLESS SPECIFIC PROVISIONS ARE STIPULATED ELSEWHERE IN THIS CONTRACT DOCUMENT, THE TERMS, CONDITIONS AND PRICING SET HEREIN ARE FIRM FOR THE LIFE OF THE CONTRACT.</p> <p>RENEWAL: THIS CONTRACT MAY BE RENEWED UPON THE MUTUAL WRITTEN CONSENT OF THE SPENDING UNIT AND VENDOR, SUBMITTED TO THE DIRECTOR OF PURCHASING THIRTY (30) DAYS PRIOR TO THE EXPIRATION DATE. SUCH RENEWAL SHALL BE IN ACCORDANCE WITH THE TERMS AND CONDITIONS OF THE ORIGINAL CONTRACT AND SHALL BE LIMITED TO FOUR (4) ONE (1) YEAR PERIODS.</p> <p>CANCELLATION: THE DIRECTOR OF PURCHASING RESERVES THE RIGHT TO CANCEL THIS CONTRACT IMMEDIATELY UPON WRITTEN NOTICE TO THE VENDOR IF THE COMMODITIES AND/OR SERVICES SUPPLIED ARE OF AN INFERIOR QUALITY OR DO NOT CONFORM TO THE SPECIFICATIONS OF THE BID AND CONTRACT HEREIN.</p> <p>OPEN MARKET CLAUSE: THE DIRECTOR OF PURCHASING MAY AUTHORIZE A SPENDING UNIT TO PURCHASE ON THE OPEN MARKET, WITHOUT THE FILING OF A REQUISITION OR COST ESTIMATE, ITEMS SPECIFIED ON THIS CONTRACT FOR IMMEDIATE DELIVERY IN EMERGENCIES DUE TO UNFORESEEN CAUSES (INCLUDING BUT NOT LIMITED TO DELAYS IN TRANSPORTATION OR AN UNANTICIPATED INCREASE IN THE VOLUME</p>						

SEE REVERSE SIDE FOR TERMS AND CONDITIONS

SIGNATURE *William K. Shreve* TELEPHONE **847-236-7280** DATE **2/20/09**
 TITLE **VP, SALES/CUSTOMER OPS** FEIN **95-2802182** ADDRESS CHANGES TO BE NOTED ABOVE

WHEN RESPONDING TO RFQ, INSERT NAME AND ADDRESS IN SPACE ABOVE LABELED 'VENDOR'



State of West Virginia
 Department of Administration
 Purchasing Division
 2019 Washington Street East
 Post Office Box 50130
 Charleston, WV 25305-0130

Request for Quotation

RFQ NUMBER:
 WEH90053

PAGE:
 3

ADDRESS CORRESPONDENCE TO ATTENTION OF:
 ROBERTA WAGNER
 304-558-0067

*603160724 800-267-5387
 DADE BEHRING INC
 SET TO PURGE
 1717 DEERFIELD RD
 DEERFIELD IL 60015-0780

HEALTH AND HUMAN RESOURCES
 WELCH COMMUNITY HOSPITAL

 454 MCDOWELL STREET
 WELCH, WV
 24801 304-436-8710

V
E
N
D
O
R

S
H
I
P
T
O

DATE PRINTED	TERMS OF SALE	SHIP VIA	F.O.B.	FREIGHT TERMS
01/28/2009				

BID OPENING DATE: 02/26/2009 BID OPENING TIME 01:30PM

LINE	QUANTITY	UOP	CAT. NO.	ITEM NUMBER	UNIT PRICE	AMOUNT
<p>OF WORK.)</p> <p>QUANTITIES: QUANTITIES LISTED IN THE REQUISITION ARE APPROXIMATIONS ONLY, BASED ON ESTIMATES SUPPLIED BY THE STATE SPENDING UNIT. IT IS UNDERSTOOD AND AGREED THAT THE CONTRACT SHALL COVER THE QUANTITIES ACTUALLY ORDERED FOR DELIVERY DURING THE TERM OF THE CONTRACT, WHETHER MORE OR LESS THAN THE QUANTITIES SHOWN.</p> <p>ORDERING PROCEDURE: SPENDING UNIT(S) SHALL ISSUE A WRITTEN STATE CONTRACT ORDER (FORM NUMBER WV-39) TO THE VENDOR FOR COMMODITIES COVERED BY THIS CONTRACT. THE ORIGINAL COPY OF THE WV-39 SHALL BE MAILED TO THE VENDOR AS AUTHORIZATION FOR SHIPMENT, A SECOND COPY MAILED TO THE PURCHASING DIVISION, AND A THIRD COPY RETAINED BY THE SPENDING UNIT.</p> <p>BANKRUPTCY: IN THE EVENT THE VENDOR/CONTRACTOR FILES FOR BANKRUPTCY PROTECTION, THIS CONTRACT IS AUTOMATICALLY NULL AND VOID, AND IS TERMINATED WITHOUT FURTHER ORDER.</p> <p>THE TERMS AND CONDITIONS CONTAINED IN THIS CONTRACT SHALL SUPERSEDE ANY AND ALL SUBSEQUENT TERMS AND CONDITIONS WHICH MAY APPEAR ON ANY ATTACHED PRINTED DOCUMENTS SUCH AS PRICE LISTS, ORDER FORMS, SALES AGREEMENTS OR MAINTENANCE AGREEMENTS, INCLUDING ANY ELECTRONIC MEDIUM SUCH AS CD-ROM.</p> <p>REV. 04/11/2001</p> <p>INQUIRIES WRITTEN QUESTIONS SHALL BE ACCEPTED THROUGH CLOSE OF BUSINESS ON 02/10/2009. QUESTIONS MAY BE SENT VIA USPS, FAX, COURIER OR E-MAIL. IN ORDER TO ASSURE NO VENDOR RECEIVES AN UNFAIR ADVANTAGE, NO SUBSTANTIVE QUESTIONS</p>						

SEE REVERSE SIDE FOR TERMS AND CONDITIONS

SIGNATURE *Wunamk Stene* TELEPHONE 847-236-7280 DATE 2/20/09

TITLE VP, SALES/CUSTOMER OPS FEIN 95-2802182 ADDRESS CHANGES TO BE NOTED ABOVE

WHEN RESPONDING TO RFQ, INSERT NAME AND ADDRESS IN SPACE ABOVE LABELED 'VENDOR'



State of West Virginia
 Department of Administration
 Purchasing Division
 2019 Washington Street East
 Post Office Box 50130
 Charleston, WV 25305-0130

Request for Quotation

RFQ NUMBER
 WEH90053

PAGE
 4

ADDRESS CORRESPONDENCE TO ATTENTION OF
 ROBERTA WAGNER
 304-558-0067

*603160724 800-267-5387

DADE BEHRING INC
 SET TO PURGE
 1717 DEERFIELD RD
 DEERFIELD IL 60015-0780

HEALTH AND HUMAN RESOURCES
 WELCH COMMUNITY HOSPITAL
 454 MCDOWELL STREET
 WELCH, WV 24801 304-436-8710

DATE PRINTED	TERMS OF SALE	SHIP VIA	F.O.B.	FREIGHT TERMS
01/28/2009				

BID OPENING DATE: 02/26/2009 BID OPENING TIME 01:30PM

LINE	QUANTITY	UOP	CAT NO	ITEM NUMBER	UNIT PRICE	AMOUNT
<p>WILL BE ANSWERED ORALLY. IF POSSIBLE, E-MAIL QUESTIONS ARE PREFERRED. ADDRESS INQUIRIES TO:</p> <p>ROBERTA WAGNER DEPARTMENT OF ADMINISTRATION PURCHASING DIVISION 2019 WASHINGTON STREET, EAST CHARLESTON, WV 25311</p> <p>FAX: 304-558-4115 E-MAIL: ROBERTA.A.WAGNER@WV.GOV</p> <p>PLEASE NOTE THIS IS A REBID OF WEH80221 & WEH80234.</p> <p>EXHIBIT 6</p> <p>PRICE ADJUSTMENT PROVISION: THE STATE OF WEST VIRGINIA WILL CONSIDER BIDS THAT CONTAIN PROVISIONS FOR PRICE ADJUSTMENTS PRIOR TO THE ORIGINAL EXPIRATION OF THE CONTRACT, PROVIDED THAT SUCH PRICE ADJUSTMENT COVERS BOTH UPWARD AND DOWNWARD MOVEMENT OF THE COMMODITY PRICE, AND THAT ADJUSTMENT IS BASED ON THE "PASS THROUGH" INCREASE OR DECREASE OF RAW MATERIALS AND/OR LABOR, WHICH MAKE UP ALL OR A SUBSTANTIAL PART OF A PRODUCT. ADJUSTMENTS ARE TO BE BASED UPON AN ACTUAL DOLLAR FIGURE, NOT A PERCENTAGE. ALL PRICE ADJUSTMENT REQUESTS MUST BE SUBSTANTIATED IN A MANNER ACCEPTABLE TO THE DIRECTOR PURCHASING, E.G. GOVERNMENTAL BENCH MARKS, GENERAL MARKET INCREASE, PUBLISHED PRICE LISTS. SUCH REQUESTS FOR AND INCREASE SHOULD BE RECEIVED IN WRITING BY THE DIRECTOR OF PURCHASING AT LEAST 30 DAYS IN ADVANCE OF THE EFFECTIVE DATE OF THE INCREASE. ANY TIME THE VENDOR REQUESTS A</p>						

SEE REVERSE SIDE FOR TERMS AND CONDITIONS

SIGNATURE *William R. Stover* TELEPHONE 847-236-7280 DATE 2/20/09

TITLE VP, SALES / CUSTOMER ASS. FEIN 95-2802182 ADDRESS CHANGES TO BE NOTED ABOVE

WHEN RESPONDING TO RFQ, INSERT NAME AND ADDRESS IN SPACE ABOVE LABELED 'VENDOR'



State of West Virginia
 Department of Administration
 Purchasing Division
 2019 Washington Street East
 Post Office Box 50130
 Charleston, WV 25305-0130

Request for Quotation

RFQ NUMBER
 WEH90053

PAGE
 5

ADDRESS CORRESPONDENCE TO ATTENTION OF
 ROBERTA WAGNER
 304-558-0067

*603160724 800-267-5387
 DADE BEHRING INC
 SET TO PURGE
 1717 DEERFIELD RD
 DEERFIELD IL 60015-0780

HEALTH AND HUMAN RESOURCES
 WELCH COMMUNITY HOSPITAL
 454 MCDOWELL STREET
 WELCH, WV 24801 304-436-8710

DATE PRINTED	TERMS OF SALE	SHIP VIA	F.O.B.	FREIGHT TERMS
01/28/2009				

BID OPENING DATE: 02/26/2009 BID OPENING TIME 01:30PM

LINE	QUANTITY	UOP	CAT NO	ITEM NUMBER	UNIT PRICE	AMOUNT
<p>PRICE ADJUSTMENT, THE PURCHASING DIVISION MAY EITHER ACCEPT THE PRICE ADJUSTMENT AND AMEND THE CONTRACT ACCORDINGLY OR REJECT THE ADJUSTMENT IN ITS ENTIRETY AND CANCEL THE CONTRACT.</p> <p>PREFERRED TERMS: IT IS PREFERRED THAT THE PRICES ON THIS CONTRACT ARE FIRM FOR LIFE OF THE CONTRACT, AS INDICATED IN THE LIFE OF CONTRACT CLAUSE CONTAINED HEREIN, NOT TO EXCEED ONE (1) YEAR.</p> <p>IF THE VENDOR CANNOT GUARANTEE A FIRM PRICE FOR THE LIFE OF CONTRACT, HE MUST INDICATE ONE OF THE PARAGRAPHS LISTED BELOW. FAILURE TO QUALIFY THE PREFERRED TERMS WILL BIND THE VENDOR TO A FIRM PRICE FOR THE LIFE OF THE CONTRACT.</p> <p>ALTERNATE TERMS: () THE PRICES ON THIS CONTRACT WILL REMAIN FIRM FOR DAYS AFTER THE EFFECTIVE DATE OF THE CONTRACT. PRICES WILL REMAIN FIRM AFTER EACH PRIC ADJUSTMENT FOR A MINIMUM OF DAYS. () THE VENDOR DOES NOT AGREE TO MAINTAIN A FIRM PRICE FOR THE LENGTH OF THE CONTRACT BUT OFFERS AN ALTERNATE PROPOSAL AS FOLLOWS: </p> <p>THE MODEL/BRAND/SPECIFICATIONS NAMED HEREIN ESTABLISH THE ACCEPTABLE LEVEL OF QUALITY ONLY AND ARE NOT INTENDED TO REFLECT A PREFERENCE OR FAVOR ANY</p>						

SEE REVERSE SIDE FOR TERMS AND CONDITIONS

SIGNATURE *Wanda K. Stree* TELEPHONE 847-236-7280 DATE 2/20/09

TITLE VP, SALES/CUSTOMER OPS FEIN 95-2802182 ADDRESS CHANGES TO BE NOTED ABOVE

WHEN RESPONDING TO RFQ, INSERT NAME AND ADDRESS IN SPACE ABOVE LABELED 'VENDOR'



State of West Virginia
 Department of Administration
 Purchasing Division
 2019 Washington Street East
 Post Office Box 50130
 Charleston, WV 25305-0130

Request for Quotation

RFQ NUMBER
WEH90053

PAGE
6

ADDRESS CORRESPONDENCE TO ATTENTION OF
ROBERTA WAGNER 304-558-0067

VENDOR

*603160724 800-267-5387
 DADE BEHRING INC
 SET TO PURGE
 1717 DEERFIELD RD
 DEERFIELD IL 60015-0780

SHIP TO

HEALTH AND HUMAN RESOURCES
 WELCH COMMUNITY HOSPITAL

 454 MCDOWELL STREET
 WELCH, WV
 24801 304-436-8710

DATE PRINTED	TERMS OF SALE	SHIP VIA	F.O.B.	FREIGHT TERMS
01/28/2009				

BID OPENING DATE: 02/26/2009 BID OPENING TIME 01:30PM

LINE	QUANTITY	UQP	CAT. NO.	ITEM NUMBER	UNIT PRICE	AMOUNT
<p>PARTICULAR BRAND OR VENDOR. VENDORS WHO ARE BIDDING ALTERNATES SHOULD SO STATE AND INCLUDE PERTINENT LITERATURE AND SPECIFICATIONS. FAILURE TO PROVIDE INFORMATION FOR ANY ALTERNATES MAY BE GROUNDS FOR REJECTION OF THE BID. THE STATE RESERVES THE RIGHT TO WAIVE MINOR IRREGULARITIES IN BIDS OR SPECIFICATION IN ACCORDANCE WITH SECTION 148-1-4(F) OF THE WEST VIRGINIA LEGISLATIVE RULES AND REGULATIONS.</p> <p>PURCHASING CARD ACCEPTANCE: THE STATE OF WEST VIRGINIA CURRENTLY UTILIZES A VISA PURCHASING CARD PROGRAM WHICH IS ISSUED THROUGH A BANK. THE SUCCESSFUL VENDOR MUST ACCEPT THE STATE OF WEST VIRGINIA VISA PURCHASING CARD FOR PAYMENT OF ALL ORDERS PLACED BY ANY STATE AGENCY AS A CONDITION OF AWARD.</p> <p style="text-align: center;">NOTICE</p> <p>A SIGNED BID MUST BE SUBMITTED TO:</p> <p style="text-align: center;">DEPARTMENT OF ADMINISTRATION PURCHASING DIVISION BUILDING 15 2019 WASHINGTON STREET, EAST CHARLESTON, WV 25305-0130</p> <p>PLEASE NOTE: A CONVENIENCE COPY WOULD BE APPRECIATED.</p> <p>THE BID SHOULD CONTAIN THIS INFORMATION ON THE FACE OF THE ENVELOPE OR THE BID MAY NOT BE CONSIDERED:</p> <p>SEALED BID</p>						

SEE REVERSE SIDE FOR TERMS AND CONDITIONS		
SIGNATURE <i>William K. Steen</i>	TELEPHONE 847-236-7280	DATE 2/20/09
TITLE VP, SALES / CUSTOMER DES.	FEIN 95-2802182	ADDRESS CHANGES TO BE NOTED ABOVE

WHEN RESPONDING TO RFQ, INSERT NAME AND ADDRESS IN SPACE ABOVE LABELED 'VENDOR'



State of West Virginia
 Department of Administration
 Purchasing Division
 2019 Washington Street East
 Post Office Box 50130
 Charleston, WV 25305-0130

Request for Quotation

RFQ NUMBER
WEH90053

PAGE
7

ADDRESS CORRESPONDENCE TO ATTENTION OF
ROBERTA WAGNER 304-558-0067

VENDOR

*603160724 800-267-5387
 DADE BEHRING INC
 SET TO PURGE
 1717 DEERFIELD RD
 DEERFIELD IL 60015-0780

SHIP TO

HEALTH AND HUMAN RESOURCES
 WELCH COMMUNITY HOSPITAL

 454 MCDOWELL STREET
 WELCH, WV 24801 304-436-8710

DATE PRINTED	TERMS OF SALE	SHIP VIA	F.O.B.	FREIGHT TERMS
01/28/2009				

BID OPENING DATE: 02/26/2009 BID OPENING TIME 01:30PM

LINE	QUANTITY	UOP	CAT NO	ITEM NUMBER	UNIT PRICE	AMOUNT
BUYER:-----RW/FILE 22-----						
RFQ. NO.:-----WEH90053-----						
BID OPENING DATE:-----2/26/2009-----						
BID OPENING TIME:-----1:30 PM-----						
PLEASE PROVIDE A FAX NUMBER IN CASE IT IS NECESSARY TO CONTACT YOU REGARDING YOUR BID:						
-----FAX: 304-757-0204-----						
CONTACT PERSON (PLEASE PRINT CLEARLY):						
-----SALLY JONES-----						
-----Phone: 304-541-5413-----						
***** THIS IS THE END OF RFQ WEH90053 ***** TOTAL:						

SEE REVERSE SIDE FOR TERMS AND CONDITIONS		
SIGNATURE <i>William K. Stevens</i>	TELEPHONE 847-236-7280	DATE 2/20/09
TITLE VP, SALES/CUSTOMER OPS	FEIN 95-2802182	ADDRESS CHANGES TO BE NOTED ABOVE

WHEN RESPONDING TO RFQ, INSERT NAME AND ADDRESS IN SPACE ABOVE LABELED 'VENDOR'

STATE OF WEST VIRGINIA
Purchasing Division**PURCHASING AFFIDAVIT****VENDOR OWING A DEBT TO THE STATE:**

West Virginia Code §5A-3-10a provides that: No contract or renewal of any contract may be awarded by the state or any of its political subdivisions to any vendor or prospective vendor when the vendor or prospective vendor or a related party to the vendor or prospective vendor is a debtor and the debt owed is an amount greater than one thousand dollars in the aggregate.

PUBLIC IMPROVEMENT CONTRACTS & DRUG-FREE WORKPLACE ACT:

If this is a solicitation for a public improvement construction contract, the vendor, by its signature below, affirms that it has a written plan for a drug-free workplace policy in compliance with Article 1D, Chapter 21 of the *West Virginia Code*. The vendor **must** make said affirmation with its bid submission. Further, public improvement construction contract may not be awarded to a vendor who does not have a written plan for a drug-free workplace policy in compliance with Article 1D, Chapter 21 of the *West Virginia Code* and who has not submitted that plan to the appropriate contracting authority in timely fashion. For a vendor who is a subcontractor, compliance with Section 5, Article 1D, Chapter 21 of the *West Virginia Code* may take place before their work on the public improvement is begun.

ANTITRUST:

In submitting a bid to any agency for the state of West Virginia, the bidder offers and agrees that if the bid is accepted the bidder will convey, sell, assign or transfer to the state of West Virginia all rights, title and interest in and to all causes of action it may now or hereafter acquire under the antitrust laws of the United States and the state of West Virginia for price fixing and/or unreasonable restraints of trade relating to the particular commodities or services purchased or acquired by the state of West Virginia. Such assignment shall be made and become effective at the time the purchasing agency tenders the initial payment to the bidder.

I certify that this bid is made without prior understanding, agreement, or connection with any corporation, firm, limited liability company, partnership or person or entity submitting a bid for the same materials, supplies, equipment or services and is in all respects fair and without collusion or fraud. I further certify that I am authorized to sign the certification on behalf of the bidder or this bid.

LICENSING:

Vendors must be licensed and in good standing in accordance with any and all state and local laws and requirements by any state or local agency of West Virginia, including, but not limited to, the West Virginia Secretary of State's Office, the West Virginia Tax Department, West Virginia Insurance Commission, or any other state agencies or political subdivision. Furthermore, the vendor must provide all necessary releases to obtain information to enable the Director or spending unit to verify that the vendor is licensed and in good standing with the above entities.

CONFIDENTIALITY:

The vendor agrees that he or she will not disclose to anyone, directly or indirectly, any such personally identifiable information or other confidential information gained from the agency, unless the individual who is the subject of the information consents to the disclosure in writing or the disclosure is made pursuant to the agency's policies, procedures and rules. Vendor further agrees to comply with the Confidentiality Policies and Information Security Accountability Requirements, set forth in <http://www.state.wv.us/admin/purchase/privacy/noticeConfidentiality.pdf>.

Under penalty of law for false swearing (*West Virginia Code* §61-5-3), it is hereby certified that the vendor affirms and acknowledges the information in this affidavit and is in compliance with the requirements as stated.

Vendor's Name: SIEMENS HEALTHCARE DIAGNOSTICSAuthorized Signature: William K. StrelkeDate: 2/20/2009

Purchasing Affidavit (Revised 01/01/09) WILLIAM STRELKE,
VP, SALES / CUSTOMER OPS

VENDOR PREFERENCE CERTIFICATE

Certification and application* is hereby made for Preference in accordance with West Virginia Code, §5A-3-37. (Does not apply to construction contracts). West Virginia Code, §5A-3-37, provides an opportunity for qualifying vendors to request (at the time of bid) preference for their residency status. Such preference is an evaluation method only and will be applied only to the cost bid in accordance with the West Virginia Code. This certificate for application is to be used to request such preference. The Purchasing Division will make the determination of the Resident Vendor Preference, if applicable.

- 1. Application is made for 2.5% resident vendor preference for the reason checked: Bidder is an individual resident vendor and has resided continuously in West Virginia for four (4) years immediately preceding the date of this certification; or, Bidder is a partnership, association or corporation resident vendor and has maintained its headquarters or principal place of business continuously in West Virginia for four (4) years immediately preceding the date of this certification; or 80% of the ownership interest of Bidder is held by another individual, partnership, association or corporation resident vendor who has maintained its headquarters or principal place of business continuously in West Virginia for four (4) years immediately preceding the date of this certification; or, Bidder is a nonresident vendor which has an affiliate or subsidiary which employs a minimum of one hundred state residents and which has maintained its headquarters or principal place of business within West Virginia continuously for the four (4) years immediately preceding the date of this certification; or,
2. Application is made for 2.5% resident vendor preference for the reason checked: Bidder is a resident vendor who certifies that, during the life of the contract, on average at least 75% of the employees working on the project being bid are residents of West Virginia who have resided in the state continuously for the two years immediately preceding submission of this bid; or,
3. Application is made for 2.5% resident vendor preference for the reason checked: Bidder is a nonresident vendor employing a minimum of one hundred state residents or is a nonresident vendor with an affiliate or subsidiary which maintains its headquarters or principal place of business within West Virginia employing a minimum of one hundred state residents who certifies that, during the life of the contract, on average at least 75% of the employees or Bidder's affiliate's or subsidiary's employees are residents of West Virginia who have resided in the state continuously for the two years immediately preceding submission of this bid; or,
4. Application is made for 5% resident vendor preference for the reason checked: Bidder meets either the requirement of both subdivisions (1) and (2) or subdivision (1) and (3) as stated above; or,
5. Application is made for 3.5% resident vendor preference who is a veteran for the reason checked: Bidder is an individual resident vendor who is a veteran of the United States armed forces, the reserves or the National Guard and has resided in West Virginia continuously for the four years immediately preceding the date on which the bid is submitted; or,
6. Application is made for 3.5% resident vendor preference who is a veteran for the reason checked: Bidder is a resident vendor who is a veteran of the United States armed forces, the reserves or the National Guard, if, for purposes of producing or distributing the commodities or completing the project which is the subject of the vendor's bid and continuously over the entire term of the project, on average at least seventy-five percent of the vendor's employees are residents of West Virginia who have resided in the state continuously for the two immediately preceding years.

Bidder understands if the Secretary of Revenue determines that a Bidder receiving preference has failed to continue to meet the requirements for such preference, the Secretary may order the Director of Purchasing to: (a) reject the bid; or (b) assess a penalty against such Bidder in an amount not to exceed 5% of the bid amount and that such penalty will be paid to the contracting agency or deducted from any unpaid balance on the contract or purchase order.

By submission of this certificate, Bidder agrees to disclose any reasonably requested information to the Purchasing Division and authorizes the Department of Revenue to disclose to the Director of Purchasing appropriate information verifying that Bidder has paid the required business taxes, provided that such information does not contain the amounts of taxes paid nor any other information deemed by the Tax Commissioner to be confidential.

Under penalty of law for false swearing (West Virginia Code, §61-5-3), Bidder hereby certifies that this certificate is true and accurate in all respects; and that if a contract is issued to Bidder and if anything contained within this certificate changes during the term of the contract, Bidder will notify the Purchasing Division in writing immediately.

Bidder: SIEMENS HEALTHCARE DIAGNOSTICS Signed: William K. Streetke
Date: 2/20/2009 Title: VP, SALES / CUSTOMER OPS

*Check any combination of preference consideration(s) indicated above, which you are entitled to receive.

AGREEMENT ADDENDUM

In the event of conflict between this addendum and the agreement, this addendum shall control:

1. **DISPUTES** - Any references in the agreement to arbitration or to the jurisdiction of any court are hereby deleted. Disputes arising out of the agreement shall be presented to the West Virginia Court of Claims.
2. **HOLD HARMLESS** - Any clause requiring the Agency to indemnify or hold harmless any party is hereby deleted in its entirety.
3. **GOVERNING LAW** - The agreement shall be governed by the laws of the State of West Virginia. This provision replaces any references to any other State's governing law.
4. **TAXES** - Provisions in the agreement requiring the Agency to pay taxes are deleted. As a State entity, the Agency is exempt from Federal, State, and local taxes and will not pay taxes for any Vendor including individuals, nor will the Agency file any tax returns or reports on behalf of Vendor or any other party.
5. **PAYMENT** - Any references to prepayment are deleted. Payment will be in arrears.
6. **INTEREST** - Should the agreement include a provision for interest on late payments, the Agency agrees to pay the maximum legal rate under West Virginia law. All other references to interest or late charges are deleted.
7. **RECOUPMENT** - Any language in the agreement waiving the Agency's right to set-off, counterclaim, recoupment, or other defense is hereby deleted.
8. **FISCAL YEAR FUNDING** - Service performed under the agreement may be continued in succeeding fiscal years for the term of the agreement, contingent upon funds being appropriated by the Legislature or otherwise being available for this service. In the event funds are not appropriated or otherwise available for this service, the agreement shall terminate without penalty on June 30. After that date, the agreement becomes of no effect and is null and void. However, the Agency agrees to use its best efforts to have the amounts contemplated under the agreement included in its budget. Non-appropriation or non-funding shall not be considered an event of default.
9. **STATUTE OF LIMITATION** - Any clauses limiting the time in which the Agency may bring suit against the Vendor, lessor, individual, or any other party are deleted.
10. **SIMILAR SERVICES** - Any provisions limiting the Agency's right to obtain similar services or equipment in the event of default or non-funding during the term of the agreement are hereby deleted.
11. **ATTORNEY FEES** - The Agency recognizes an obligation to pay attorney's fees or costs only when assessed by a court of competent jurisdiction. Any other provision is invalid and considered null and void.
12. **ASSIGNMENT** - Notwithstanding any clause to the contrary, the Agency reserves the right to assign the agreement to another State of West Virginia agency, board or commission upon thirty (30) days written notice to the Vendor and Vendor shall obtain the written consent of Agency prior to assigning the agreement.
13. **LIMITATION OF LIABILITY** - The Agency, as a State entity, cannot agree to assume the potential liability of a Vendor. Accordingly, any provision limiting the Vendor's liability for direct damages to a certain dollar amount or to the amount of the agreement is hereby deleted. Limitations on special, incidental or consequential damages are acceptable. In addition, any limitation is null and void to the extent that it precludes any action for injury to persons or for damages to personal property.
14. **RIGHT TO TERMINATE** - Agency shall have the right to terminate the agreement upon thirty (30) days written notice to Vendor. Agency agrees to pay Vendor for services rendered or goods received prior to the effective date of termination.
15. **TERMINATION CHARGES** - Any provision requiring the Agency to pay a fixed amount or liquidated damages upon termination of the agreement is hereby deleted. The Agency may only agree to reimburse a Vendor for actual costs incurred or losses sustained during the current fiscal year due to wrongful termination by the Agency prior to the end of any current agreement term.
16. **RENEWAL** - Any reference to automatic renewal is hereby deleted. The agreement may be renewed only upon mutual written agreement of the parties.
17. **INSURANCE** - Any provision requiring the Agency to insure equipment or property of any kind and name the Vendor as beneficiary or as an additional insured is hereby deleted.
18. **RIGHT TO NOTICE** - Any provision for repossession of equipment without notice is hereby deleted. However, the Agency does recognize a right of repossession with notice.
19. **ACCELERATION** - Any reference to acceleration of payments in the event of default or non-funding is hereby deleted.
20. **CONFIDENTIALITY**: -Any provision regarding confidentiality of the terms and conditions of the agreement is hereby deleted. State contracts are public records under the West Virginia Freedom of Information Act.
21. **AMENDMENTS** - All amendments, modifications, alterations or changes to the agreement shall be in writing and signed by both parties. No amendment, modification, alteration or change may be made to this addendum without the express written approval of the Purchasing Division and the Attorney General.

ACCEPTED BY:
STATE OF WEST VIRGINIA

Spending Unit: _____

Signed: _____

Title: _____

Date: _____

VENDOR

Company Name: Siemens Healthcare Diagnostics

Signed: Sally A. [Signature]

Title: CIS

Date: 2/20/09



State of West Virginia
 Department of Administration
 Purchasing Division
 2019 Washington Street East
 Post Office Box 50130
 Charleston, WV 25305-0130

**Request for
 Quotation**

RFQ NUMBER
 WEH90053

PAGE
 1

ADDRESS CORRESPONDENCE TO ATTENTION OF
 ROBERTA WAGNER
 304-558-0067

V
E
N
D
O
R

*709070313 02 304-757-7457
 SIEMENS HEALTHCARE DIAGNOSTICS
 211 BEECHWOOD ESTATES
 SCOTT DEPOT WV 25560

S
H
I
P
T
O

HEALTH AND HUMAN RESOURCES
 WELCH COMMUNITY HOSPITAL
 454 MCDOWELL STREET
 WELCH, WV
 24801 304-436-8710

DATE PRINTED	TERMS OF SALE	SHIP VIA	F.O.B.	FREIGHT TERMS
02/12/2009				

BID OPENING DATE: 02/26/2009 BID OPENING TIME 01:30PM

LINE	QUANTITY	UOP	CAT. NO.	ITEM NUMBER	UNIT PRICE	AMOUNT
ADDENDUM NO. 1 1. QUESTIONS AND ANSWERS ARE ATTACHED. 2. ADDENDUM ACKNOWLEDGEMENT IS ATTACHED. THIS DOCUMENT SHOULD BE SIGNED AND RETURNED WITH YOUR BID. FAILURE TO SIGN AND RETURN MAY RESULT IN DISQUALIFICATION OF YOUR BID. EXHIBIT 10 REQUISITION NO.: WEH90053 ADDENDUM ACKNOWLEDGEMENT I HEREBY ACKNOWLEDGE RECEIPT OF THE FOLLOWING CHECKED ADDENDUM(S) AND HAVE MADE THE NECESSARY REVISIONS TO MY PROPOSAL, PLANS AND/OR SPECIFICATION, ETC. ADDENDUM NO.'S: NO. 1 ✓ NO. 2 NO. 3 NO. 4 NO. 5 I UNDERSTAND THAT FAILURE TO CONFIRM THE RECEIPT OF THE ADDENDUM(S) MAY BE CAUSE FOR REJECTION OF BIDS.						

SEE REVERSE SIDE FOR TERMS AND CONDITIONS

SIGNATURE <i>William K. Stene</i>	TELEPHONE 847-236-7280	DATE 2/20/09
TITLE VP, SALES/CUSTOMER CRS	FEIN 95-2802182	ADDRESS CHANGES TO BE NOTED ABOVE

WHEN RESPONDING TO RFQ, INSERT NAME AND ADDRESS IN SPACE ABOVE LABELED 'VENDOR'

GENERAL TERMS & CONDITIONS
REQUEST FOR QUOTATION (RFQ) AND REQUEST FOR PROPOSAL (RFP)

1. Awards will be made in the best interest of the State of West Virginia.
2. The State may accept or reject in part, or in whole, any bid.
3. All quotations are governed by the *West Virginia Code* and the *Legislative Rules* of the Purchasing Division.
4. Prior to any award, the apparent successful vendor must be properly registered with the Purchasing Division and have paid the required \$125 fee.
5. All services performed or goods delivered under State Purchase Order/Contracts are to be continued for the term of the Purchase Order/Contracts, contingent upon funds being appropriated by the Legislature or otherwise being made available. In the event funds are not appropriated or otherwise available for these services or goods, this Purchase Order/Contract becomes void and of no effect after June 30.
6. Payment may only be made after the delivery and acceptance of goods or services.
7. Interest may be paid for late payment in accordance with the *West Virginia Code*.
8. Vendor preference will be granted upon written request in accordance with the *West Virginia Code*.
9. The State of West Virginia is exempt from federal and state taxes and will not pay or reimburse such taxes.
10. The Director of Purchasing may cancel any Purchase Order/Contract upon 30 days written notice to the seller.
11. The laws of the State of West Virginia and the *Legislative Rules* of the Purchasing Division shall govern all rights and duties under the Contract, including without limitation the validity of this Purchase Order/Contract.
12. Any reference to automatic renewal is hereby deleted. The Contract may be renewed only upon mutual written agreement of the parties.
13. **BANKRUPTCY:** In the event the vendor/contractor files for bankruptcy protection, this Contract may be deemed null and void, and terminated without further order.
14. **HIPAA BUSINESS ASSOCIATE ADDENDUM:** The West Virginia State Government HIPAA Business Associate Addendum (BAA), approved by the Attorney General, and available online at the Purchasing Division's web site (<http://www.state.wv.us/admin/purchase/vrc/hipaa.htm>) is hereby made part of the agreement. Provided that, the Agency meets the definition of a Cover Entity (45 CFR §160.103) and will be disclosing Protected Health Information (45 CFR §160.103) to the vendor.
15. **WEST VIRGINIA ALCOHOL & DRUG-FREE WORKPLACE ACT:** If this Contract constitutes a public improvement construction contract as set forth in Article 1D, Chapter 21 of the West Virginia Code ("The West Virginia Alcohol and Drug-Free Workplace Act"), then the following language shall hereby become part of this Contract: "The contractor and its subcontractors shall implement and maintain a written drug-free workplace policy in compliance with the West Virginia Alcohol and Drug-Free Workplace Act, as set forth in Article 1D, Chapter 21 of the West Virginia Code. The contractor and its subcontractors shall provide a sworn statement in writing, under the penalties of perjury, that they maintain a valid drug-free work place policy in compliance with the West Virginia and Drug-Free Workplace Act. It is understood and agreed that this Contract shall be cancelled by the awarding authority if the Contractor: 1) Fails to implement its drug-free workplace policy; 2) Fails to provide information regarding implementation of the contractor's drug-free workplace policy at the request of the public authority; or 3) Provides to the public authority false information regarding the contractor's drug-free workplace policy."

INSTRUCTIONS TO BIDDERS

1. Use the quotation forms provided by the Purchasing Division.
2. **SPECIFICATIONS:** Items offered must be in compliance with the specifications. Any deviation from the specifications must be clearly indicated by the bidder. Alternates offered by the bidder as **EQUAL** to the specifications must be clearly defined. A bidder offering an alternate should attach complete specifications and literature to the bid. The Purchasing Division may waive minor deviations to specifications.
3. Complete all sections of the quotation form.
4. Unit prices shall prevail in case of discrepancy.
5. All quotations are considered F.O.B. destination unless alternate shipping terms are clearly identified in the quotation.
6. **BID SUBMISSION:** All quotations must be delivered by the bidder to the office listed below prior to the date and time of the bid opening. Failure of the bidder to deliver the quotations on time will result in bid disqualifications: Department of Administration, Purchasing Division, 2019 Washington Street East, P.O. Box 50130, Charleston, WV 25305-0130



State of West Virginia
 Department of Administration
 Purchasing Division
 2019 Washington Street East
 Post Office Box 50130
 Charleston, WV 25305-0130

Request for Quotation

RFQ NUMBER
 WEH90053

PAGE
 2

ADDRESS CORRESPONDENCE TO ATTENTION OF
 ROBERTA WAGNER
 304-558-0067

VENDOR

*709070313 02 304-757-7457
 SIEMENS HEALTHCARE DIAGNOSTICS
 211 BEECHWOOD ESTATES
 SCOTT DEPOT WV 25560

SHIP TO

HEALTH AND HUMAN RESOURCES
 WELCH COMMUNITY HOSPITAL
 454 MCDOWELL STREET
 WELCH, WV 24801 304-436-8710

DATE PRINTED 02/12/2009	TERMS OF SALE	SHIP VIA	FOB	FREIGHT TERMS
----------------------------	---------------	----------	-----	---------------

BID OPENING DATE: 02/26/2009 BID OPENING TIME 01:30PM

LINE	QUANTITY	UOP	CAT NO	ITEM NUMBER	UNIT PRICE	AMOUNT
<p>VENDOR MUST CLEARLY UNDERSTAND THAT ANY VERBAL REPRESENTATION MADE OR ASSUMED TO BE MADE DURING ANY ORAL DISCUSSION HELD BETWEEN VENDOR'S REPRESENTATIVES AND ANY STATE PERSONNEL IS NOT BINDING. ONLY THE INFORMATION ISSUED IN WRITING AND ADDED TO THE SPECIFICATIONS BY AN OFFICIAL ADDENDUM IS BINDING.</p> <p style="text-align: center;"> <i>Wendy K. Stueve</i> SIGNATURE SIEMENS HEALTHCARE DIAGNOSTICS COMPANY 02/20/2009 DATE </p> <p>REV. 11/96</p> <p style="text-align: right;">END OF ADDENDUM NO. 1</p>						

SEE REVERSE SIDE FOR TERMS AND CONDITIONS

SIGNATURE <i>Wendy K. Stueve</i>	TELEPHONE 847-236-7280	DATE 2/20/09
TITLE VP, SALES/CUSTOMER OPS	FEIN 95-2802182	ADDRESS CHANGES TO BE NOTED ABOVE

WHEN RESPONDING TO RFQ, INSERT NAME AND ADDRESS IN SPACE ABOVE LABELED 'VENDOR'

GENERAL TERMS & CONDITIONS
REQUEST FOR QUOTATION (RFQ) AND REQUEST FOR PROPOSAL (RFP)

1. Awards will be made in the best interest of the State of West Virginia.
2. The State may accept or reject in part, or in whole, any bid.
3. All quotations are governed by the *West Virginia Code* and the *Legislative Rules* of the Purchasing Division.
4. Prior to any award, the apparent successful vendor must be properly registered with the Purchasing Division and have paid the required \$125 fee.
5. All services performed or goods delivered under State Purchase Order/Contracts are to be continued for the term of the Purchase Order/Contracts, contingent upon funds being appropriated by the Legislature or otherwise being made available. In the event funds are not appropriated or otherwise available for these services or goods, this Purchase Order/Contract becomes void and of no effect after June 30.
6. Payment may only be made after the delivery and acceptance of goods or services.
7. Interest may be paid for late payment in accordance with the *West Virginia Code*.
8. Vendor preference will be granted upon written request in accordance with the *West Virginia Code*.
9. The State of West Virginia is exempt from federal and state taxes and will not pay or reimburse such taxes.
10. The Director of Purchasing may cancel any Purchase Order/Contract upon 30 days written notice to the seller.
11. The laws of the State of West Virginia and the *Legislative Rules* of the Purchasing Division shall govern all rights and duties under the Contract, including without limitation the validity of this Purchase Order/Contract.
12. Any reference to automatic renewal is hereby deleted. The Contract may be renewed only upon mutual written agreement of the parties.
13. **BANKRUPTCY:** In the event the vendor/contractor files for bankruptcy protection, this Contract may be deemed null and void, and terminated without further order.
14. **HIPAA BUSINESS ASSOCIATE ADDENDUM:** The West Virginia State Government HIPAA Business Associate Addendum (BAA), approved by the Attorney General, and available online at the Purchasing Division's web site (<http://www.state.wv.us/admin/purchase/vrc/hipaa.htm>) is hereby made part of the agreement. Provided that, the Agency meets the definition of a Cover Entity (45 CFR §160.103) and will be disclosing Protected Health Information (45 CFR §160.103) to the vendor.
15. **WEST VIRGINIA ALCOHOL & DRUG-FREE WORKPLACE ACT:** If this Contract constitutes a public improvement construction contract as set forth in Article 1D, Chapter 21 of the West Virginia Code ("The West Virginia Alcohol and Drug-Free Workplace Act"), then the following language shall hereby become part of this Contract: "The contractor and its subcontractors shall implement and maintain a written drug-free workplace policy in compliance with the West Virginia Alcohol and Drug-Free Workplace Act, as set forth in Article 1D, Chapter 21 of the West Virginia Code. The contractor and its subcontractors shall provide a sworn statement in writing, under the penalties of perjury, that they maintain a valid drug-free work place policy in compliance with the West Virginia and Drug-Free Workplace Act. It is understood and agreed that this Contract shall be cancelled by the awarding authority if the Contractor: 1) Fails to implement its drug-free workplace policy; 2) Fails to provide information regarding implementation of the contractor's drug-free workplace policy at the request of the public authority; or 3) Provides to the public authority false information regarding the contractor's drug-free workplace policy."

INSTRUCTIONS TO BIDDERS

1. Use the quotation forms provided by the Purchasing Division.
2. **SPECIFICATIONS:** Items offered must be in compliance with the specifications. Any deviation from the specifications must be clearly indicated by the bidder. Alternates offered by the bidder as **EQUAL** to the specifications must be clearly defined. A bidder offering an alternate should attach complete specifications and literature to the bid. The Purchasing Division may waive minor deviations to specifications.
3. Complete all sections of the quotation form.
4. Unit prices shall prevail in case of discrepancy.
5. All quotations are considered F.O.B. destination unless alternate shipping terms are clearly identified in the quotation.
6. **BID SUBMISSION:** All quotations must be delivered by the bidder to the office listed below prior to the date and time of the bid opening. Failure of the bidder to deliver the quotations on time will result in bid disqualifications: Department of Administration, Purchasing Division, 2019 Washington Street East, P.O. Box 50130, Charleston, WV 25305-0130



State of West Virginia
 Department of Administration
 Purchasing Division
 2019 Washington Street East
 Post Office Box 50130
 Charleston, WV 25305-0130

Request for Quotation

RFQ NUMBER
 WEH90053

PAGE
 3

ADDRESS CORRESPONDENCE TO ATTENTION OF
 ROBERTA WAGNER
 304-558-0067

VENDOR

*709070313 02 304-757-7457
 SIEMENS HEALTHCARE DIAGNOSTICS
 211 BEECHWOOD ESTATES
 SCOTT DEPOT WV 25560

SHIP TO

HEALTH AND HUMAN RESOURCES
 WELCH COMMUNITY HOSPITAL
 454 MCDOWELL STREET
 WELCH, WV 24801 304-436-8710

DATE PRINTED	TERMS OF SALE	SHIP VIA	FOB	FREIGHT TERMS
02/12/2009				

BID OPENING DATE: 02/26/2009 BID OPENING TIME 01:30PM

LINE	QUANTITY	UOP	CAT NO	ITEM NUMBER	UNIT PRICE	AMOUNT
0001	1	JB		193-12		
REAGENTS (FOR AUTOMATIC INSTRUMENTS)						
***** THIS IS THE END OF RFQ WEH90053 ***** TOTAL:						\$217,132. ³¹

SEE REVERSE SIDE FOR TERMS AND CONDITIONS

SIGNATURE *William C. Greene* TELEPHONE 847-236-7280 DATE 2/20/09
 TITLE VP, SALES / CUSTOMER OPS 95-2802182 ADDRESS CHANGES TO BE NOTED ABOVE

WHEN RESPONDING TO RFQ, INSERT NAME AND ADDRESS IN SPACE ABOVE LABELED 'VENDOR'

GENERAL TERMS & CONDITIONS
REQUEST FOR QUOTATION (RFQ) AND REQUEST FOR PROPOSAL (RFP)

1. Awards will be made in the best interest of the State of West Virginia.
2. The State may accept or reject in part, or in whole, any bid.
3. All quotations are governed by the *West Virginia Code* and the *Legislative Rules* of the Purchasing Division.
4. Prior to any award, the apparent successful vendor must be properly registered with the Purchasing Division and have paid the required \$125 fee.
5. All services performed or goods delivered under State Purchase Order/Contracts are to be continued for the term of the Purchase Order/Contracts, contingent upon funds being appropriated by the Legislature or otherwise being made available. In the event funds are not appropriated or otherwise available for these services or goods, this Purchase Order/Contract becomes void and of no effect after June 30.
6. Payment may only be made after the delivery and acceptance of goods or services.
7. Interest may be paid for late payment in accordance with the *West Virginia Code*.
8. Vendor preference will be granted upon written request in accordance with the *West Virginia Code*.
9. The State of West Virginia is exempt from federal and state taxes and will not pay or reimburse such taxes.
10. The Director of Purchasing may cancel any Purchase Order/Contract upon 30 days written notice to the seller.
11. The laws of the State of West Virginia and the *Legislative Rules* of the Purchasing Division shall govern all rights and duties under the Contract, including without limitation the validity of this Purchase Order/Contract.
12. Any reference to automatic renewal is hereby deleted. The Contract may be renewed only upon mutual written agreement of the parties.
13. **BANKRUPTCY:** In the event the vendor/contractor files for bankruptcy protection, this Contract may be deemed null and void, and terminated without further order.
14. **HIPAA BUSINESS ASSOCIATE ADDENDUM:** The West Virginia State Government HIPAA Business Associate Addendum (BAA), approved by the Attorney General, and available online at the Purchasing Division's web site (<http://www.state.wv.us/admin/purchase/vrc/hipaa.htm>) is hereby made part of the agreement. Provided that, the Agency meets the definition of a Cover Entity (45 CFR §160.103) and will be disclosing Protected Health Information (45 CFR §160.103) to the vendor.
15. **WEST VIRGINIA ALCOHOL & DRUG-FREE WORKPLACE ACT:** If this Contract constitutes a public improvement construction contract as set forth in Article 1D, Chapter 21 of the West Virginia Code ("The West Virginia Alcohol and Drug-Free Workplace Act"), then the following language shall hereby become part of this Contract: "The contractor and its subcontractors shall implement and maintain a written drug-free workplace policy in compliance with the West Virginia Alcohol and Drug-Free Workplace Act, as set forth in Article 1D, Chapter 21 of the West Virginia Code. The contractor and its subcontractors shall provide a sworn statement in writing, under the penalties of perjury, that they maintain a valid drug-free work place policy in compliance with the West Virginia and Drug-Free Workplace Act. It is understood and agreed that this Contract shall be cancelled by the awarding authority if the Contractor: 1) Fails to implement its drug-free workplace policy; 2) Fails to provide information regarding implementation of the contractor's drug-free workplace policy at the request of the public authority; or 3) Provides to the public authority false information regarding the contractor's drug-free workplace policy."

INSTRUCTIONS TO BIDDERS

1. Use the quotation forms provided by the Purchasing Division.
2. **SPECIFICATIONS:** Items offered must be in compliance with the specifications. Any deviation from the specifications must be clearly indicated by the bidder. Alternates offered by the bidder as **EQUAL** to the specifications must be clearly defined. A bidder offering an alternate should attach complete specifications and literature to the bid. The Purchasing Division may waive minor deviations to specifications.
3. Complete all sections of the quotation form.
4. Unit prices shall prevail in case of discrepancy.
5. All quotations are considered F.O.B. destination unless alternate shipping terms are clearly identified in the quotation.
6. **BID SUBMISSION:** All quotations must be delivered by the bidder to the office listed below prior to the date and time of the bid opening. Failure of the bidder to deliver the quotations on time will result in bid disqualifications: Department of Administration, Purchasing Division, 2019 Washington Street East, P.O. Box 50130, Charleston, WV 25305-0130

WEH90053
Addendum #1

Q1.A. Where does the registration fee of \$125 get sent?

A1.A. Completion of the Vendor Registration and Disclosure Statement (WV-1 form) and the \$125.00 annual fee must be sent to the following:

**Purchasing Division
Vendor Registration
2019 Washington Street East
P.O. Box 50130
Charleston, WV 25305-0130**

The WV-1 form can be found at:

www.state.wv.us/admin/purchase/vrc/pforms.htm

Q1.B. Does it need submitted before the bid is awarded or at that time?

A1.B. Prior to any award, the apparent successful vendor must be properly registered with the Purchasing Division and have paid the required \$125.00 fee.

Q2. A. Does the State of West Virginia qualify for Federal contract pricing and terms?

A2.A. Welch Community is a State Agency and a governmental entity. We are not eligible for federal pricing nor are we eligible for GPO pricing on anything but pharmaceuticals.

Q2.B. If so, how?

A2.B N/A

Q3. On the request for unit pricing the calibrators, controls, and consumables are specific for their current analyzers. I am assuming you want the price of ours?

A3. Yes, please submit calibrators, controls, and consumables specific for the equipment your company proposes for the estimated number of test listed on the cost sheet. Test should equal the Estimated Annual Usage per Unit multiplied by the Count per Unit.

Example:

Item No.1 26 units x 480 test per unit equals 12,480 tests

Q4. May I have copies of the original bids WEH80221 & WEH80234 and why are they being re-bid?

A4. Yes, please see the attached. WEH80221 and WEH80234 the vendor did not meet specifications within the RFQ and the vendor's quote had put conflicting information in response to mandatory specifications.



State of West Virginia
 Department of Administration
 Purchasing Division
 2019 Washington Street East
 Post Office Box 50130
 Charleston, WV 25305-0130

Request for Quotation

BFO NUMBER
WEH80221

PAGE
6

ADDRESS CORRESPONDENCE TO ATTENTION OF
ROBERTA WAGNER
304-558-0067

RFQ COPY
 TYPE NAME/ADDRESS HERE

HEALTH AND HUMAN RESOURCES
 WELCH COMMUNITY HOSPITAL

 454 MCDOWELL STREET
 WELCH, WV
 24801 304-436-8710

DATE PRINTED	TERMS OF SALE	SHIP VIA	FOB	FREIGHT TERMS
12/14/2007	01/23/2008			
BID OPENING DATE:		BID OPENING TIME		
		01:30PM		

LINE	QUANTITY	UOF	CAT NO	ITEM NUMBER	UNIT PRICE	AMOUNT
1	1	JB		193-12		
<p>OPEN-END BLANKET CONTRACT</p> <p>REAGENTS (FOR AUTOMATIC INSTRUMENTS)</p> <p>REQUEST FOR QUOTATION</p> <p>TO PROVIDE AN OPEN END CONTRACT FOR REAGENTS TO PERFORM EXAMINATION FOR DETECTION OF SPECIFIED METHODS. SELECTED VENDOR MUST PROVIDE TWO FULLY AUTOMATED ANALYZERS AT NO ADDITIONAL CHARGE FOR USE WITH THE REQUESTED REAGENTS; PER THE ATTACHED SPECIFICATIONS. THE SYSTEMS MUST INCLUDE A COMPUTER, MONITOR, AND PRINTER WHICH WILL BE RETAINED AND MAINTAINED BY THE VENDOR.</p> <p>EXHIBIT 3</p> <p>LIFE OF CONTRACT: THIS CONTRACT BECOMES EFFECTIVE ON AND EXTENDS FOR A PERIOD OF ONE (1) YEAR OR UNTIL SUCH "REASONABLE TIME", THEREAFTER AS IS NECESSARY TO OBTAIN A NEW CONTRACT OR RENEW THE ORIGINAL CONTRACT. THE "REASONABLE TIME" PERIOD SHALL NOT EXCEED TWELVE (12) MONTHS. DURING THIS "REASONABLE TIME" THE VENDOR MAY TERMINATE THIS CONTRACT FOR ANY REASON UPON GIVING THE DIRECTOR OF PURCHASING 30 DAYS WRITTEN NOTICE.</p> <p>UNLESS SPECIFIC PROVISIONS ARE STIPULATED ELSEWHERE</p>						

RECEIVED
 2007 DEC 17 AM 10:34
 OFC OF PURCHASING

SIGNATURE		TELEPHONE		DATE
TITLE		FEIN		ADDRESS CHANGES TO BE NOTED ABOVE

WHEN RESPONDING TO REQ. INSERT NAME AND ADDRESS IN SPACE ABOVE LABELS

**GENERAL TERMS & CONDITIONS
REQUEST FOR QUOTATION (RFQ) AND REQUEST FOR PROPOSAL (RFP)**

1. Awards will be made in the best interest of the State of West Virginia.
2. The State may accept or reject in part, or in whole, any bid.
3. All quotations are governed by the *West Virginia Code* and the *Legislative Rules* of the Purchasing Division.
4. Prior to any award, the apparent successful vendor must be properly registered with the Purchasing Division and have paid the required \$125.00 registration fee.
5. All services performed or goods delivered under State Purchase Orders/Contracts are to be continued for the term of the Purchase Order/Contract, contingent upon funds being appropriated by the Legislature or otherwise being made available. In the event funds are not appropriated or otherwise available for these services or goods, this Purchase Order/Contract becomes void and of no effect after June 30.
6. Payment may only be made after the delivery and acceptance of goods or services.
7. Interest may be paid for late payment in accordance with the *West Virginia Code*.
8. Vendor preference will be granted upon written request in accordance with the *West Virginia Code*.
9. The State of West Virginia is exempt from federal and state taxes and will not pay or reimburse such taxes.
10. The Director of Purchasing may cancel any Purchase Order/Contract upon 30 days written notice to the seller.
11. The laws of the State of West Virginia and the *Legislative Rules* of the Purchasing Division shall govern all rights and duties under the Contract, including without limitation the validity of this Purchase Order/Contract.
12. Any reference to automatic renewal is hereby deleted. The Contract may be renewed only upon mutual written agreement of the parties.
13. **BANKRUPTCY:** In the event the vendor/contractor files for bankruptcy protection, this Contract may be deemed null and void, and terminated without further order.
14. **HIPAA Business Associate Addendum -** The West Virginia State Government HIPAA Business Associate Addendum (BAA), approved by the Attorney General, and available online at the Purchasing Division's web site (<http://www.state.wv.us/admin/purchase/vrc/hipaa.htm>) is hereby made part of the agreement. Provided that, the Agency meets the definition of a Covered Entity (45 CFR §160.103) and will be disclosing Protected Health Information (45 CFR §160.103) to the vendor.

INSTRUCTIONS TO BIDDERS

1. Use the quotation forms provided by the Purchasing Division.
2. **SPECIFICATIONS:** Items offered must be in compliance with the specifications. Any deviation from the specifications must be clearly indicated by the bidder. Alternates offered by the bidder as EQUAL to the specifications must be clearly defined. A bidder offering an alternate should attach complete specifications and literature to the bid. The Purchasing Division may waive minor deviations to specifications.
3. Complete all sections of the quotation form.
4. Unit prices shall prevail in cases of discrepancy.
5. All quotations are considered F.O.B. destination unless alternate shipping terms are clearly identified in the quotation.
6. **BID SUBMISSION:** All quotations must be delivered by the bidder to the office listed below prior to the date and time of the bid opening. Failure of the bidder to deliver the quotations on time will result in bid disqualifications.

SIGNED BID TO:

Department of Administration
Purchasing Division
2019 Washington Street East
Post Office Box 50130
Charleston, WV 25305-0130



State of West Virginia
 Department of Administration
 Purchasing Division
 2019 Washington Street East
 Post Office Box 50130
 Charleston, WV 25305-0130

Request for Quotation

RFQ NUMBER
 WEH80221

PAGE
 8

ADDRESS CORRESPONDENCE TO ATTENTION OF
 ROBERTA WAGNER
 304-558-0067

RFQ COPY

TYPE NAME/ADDRESS HERE

PURCHASING DIVISION

SHIP TO

HEALTH AND HUMAN RESOURCES
 WELCH COMMUNITY HOSPITAL

454 MCDOWELL STREET
 WELCH, WV
 24801 304-436-8710

DATE PRINTED	TERMS OF SALE	SHIP VIA	FOB	FREIGHT TERMS
12/14/2007				
BID OPENING DATE: 01/23/2008		BID OPENING TIME 01:30PM		

LINE	QUANTITY	UOP	CAT NO	ITEM NUMBER	UNIT PRICE	AMOUNT
<p>IN THIS CONTRACT DOCUMENT, THE TERMS, CONDITIONS AND PRICING SET HEREIN ARE FIRM FOR THE LIFE OF THE CONTRACT.</p> <p>RENEWAL: THIS CONTRACT MAY BE RENEWED UPON THE MUTUAL WRITTEN CONSENT OF THE SPENDING UNIT AND VENDOR, SUBMITTED TO THE DIRECTOR OF PURCHASING THIRTY (30) DAYS PRIOR TO THE EXPIRATION DATE. SUCH RENEWAL SHALL BE IN ACCORDANCE WITH THE TERMS AND CONDITIONS OF THE ORIGINAL CONTRACT AND SHALL BE LIMITED TO TWO (2) ONE (1) YEAR PERIODS.</p> <p>CANCELLATION: THE DIRECTOR OF PURCHASING RESERVES THE RIGHT TO CANCEL THIS CONTRACT IMMEDIATELY UPON WRITTEN NOTICE TO THE VENDOR IF THE COMMODITIES AND/OR SERVICES SUPPLIED ARE OF AN INFERIOR QUALITY OR DO NOT CONFORM TO THE SPECIFICATIONS OF THE BID AND CONTRACT HEREIN.</p> <p>OPEN MARKET CLAUSE: THE DIRECTOR OF PURCHASING MAY AUTHORIZE A SPENDING UNIT TO PURCHASE ON THE OPEN MARKET, WITHOUT THE FILING OF A REQUISITION OR COST ESTIMATE, ITEMS SPECIFIED ON THIS CONTRACT FOR IMMEDIATE DELIVERY IN EMERGENCIES DUE TO UNFORESEEN CAUSES (INCLUDING BUT NOT LIMITED TO DELAYS IN TRANSPORTATION OR AN UNANTICIPATED INCREASE IN THE VOLUME OF WORK.)</p> <p>QUANTITIES: QUANTITIES LISTED IN THE REQUISITION ARE APPROXIMATIONS ONLY, BASED ON ESTIMATES SUPPLIED BY THE STATE SPENDING UNIT. IT IS UNDERSTOOD AND AGREED THAT THE CONTRACT SHALL COVER THE QUANTITIES ACTUALLY ORDERED FOR DELIVERY DURING THE TERM OF THE CONTRACT, WHETHER MORE OR LESS THAN THE QUANTITIES SHOWN.</p> <p>ORDERING PROCEDURE: SPENDING UNIT(S) SHALL ISSUE A WRITTEN STATE CONTRACT ORDER (FORM NUMBER WV-39) TO</p>						

SEE REVERSE SIDE FOR TERMS AND CONDITIONS

SIGNATURE	TELEPHONE	DATE
TITLE	FEN	ADDRESS CHANGES TO BE NOTED ABOVE

WHEN RESPONDING TO RFQ INSERT NAME AND ADDRESS IN SPACE ABOVE LABELLED 'VENDOR'



State of West Virginia
 Department of Administration
 Purchasing Division
 2019 Washington Street East
 Post Office Box 50130
 Charleston, WV 25305-0130

Request for Quotation

RFQ NUMBER
 WEH80221

PAGE
 3

ADDRESS CORRESPONDENCE TO ATTENTION OF
 ROBERTA WAGNER
 304-558-0067

RFQ COPY

TYPE NAME/ADDRESS HERE

HEALTH AND HUMAN RESOURCES
 WELCH COMMUNITY HOSPITAL

454 MCDOWELL STREET
 WELCH, WV
 24801 304-436-8710

DATE PRINTED	TERMS OF SALE	SHIP VIA	FOB	FREIGHT TERMS
12/14/2007				
BID OPENING DATE: 01/23/2008		BID OPENING TIME 01:30PM		

LINE	QUANTITY	UOP	CAT NO	ITEM NUMBER	UNIT PRICE	AMOUNT
<p>THE VENDOR FOR COMMODITIES COVERED BY THIS CONTRACT. THE ORIGINAL COPY OF THE WV-39 SHALL BE MAILED TO THE VENDOR AS AUTHORIZATION FOR SHIPMENT, A SECOND COPY MAILED TO THE PURCHASING DIVISION, AND A THIRD COPY RETAINED BY THE SPENDING UNIT.</p> <p>BANKRUPTCY: IN THE EVENT THE VENDOR/CONTRACTOR FILES FOR BANKRUPTCY PROTECTION, THIS CONTRACT IS AUTOMATICALLY NULL AND VOID, AND IS TERMINATED WITHOUT FURTHER ORDER.</p> <p>THE TERMS AND CONDITIONS CONTAINED IN THIS CONTRACT SHALL SUPERSEDE ANY AND ALL SUBSEQUENT TERMS AND CONDITIONS WHICH MAY APPEAR ON ANY ATTACHED PRINTED DOCUMENTS SUCH AS PRICE LISTS, ORDER FORMS, SALES AGREEMENTS OR MAINTENANCE AGREEMENTS, INCLUDING ANY ELECTRONIC MEDIUM SUCH AS CD-ROM.</p> <p>REV. 04/11/2001.</p> <p>INQUIRIES WRITTEN QUESTIONS SHALL BE ACCEPTED THROUGH CLOSE OF BUSINESS ON 1/4/2008. QUESTIONS MAY BE SENT VIA USPS, FAX, COURIER OR E-MAIL. IN ORDER TO ASSURE NO VENDOR RECEIVES AN UNFAIR ADVANTAGE, NO SUBSTANTIVE QUESTIONS WILL BE ANSWERED ORALLY. IF POSSIBLE, E-MAIL QUESTIONS ARE PREFERRED. ADDRESS INQUIRIES TO:</p> <p>ROBERTA WAGNER DEPARTMENT OF ADMINISTRATION PURCHASING DIVISION 2019 WASHINGTON STREET, EAST CHARLESTON, WV 25311</p> <p>FAX: 304-558-4115 E-MAIL: RWAGNER@WVADMIN.GOV</p>						

SEE REVERSE SIDE FOR TERMS AND CONDITIONS

SIGNATURE	TELEPHONE	DATE
-----------	-----------	------

TITLE	FEIN	ADDRESS CHANGES TO BE NOTED ABOVE
-------	------	-----------------------------------

WHEN RESPONDING TO REQ, INSERT NAME AND ADDRESS IN SPACE ABOVE LABELLED 'VENDOR'



State of West Virginia
 Department of Administration
 Purchasing Division
 2019 Washington Street East
 Post Office Box 50130
 Charleston, WV 25305-0130

Request for Quotation

RFQ NUMBER
 WEH80221

PAGE
 10

ADDRESS CORRESPONDENCE TO ATTENTION OF
 ROBERTA WAGNER
 304-558-0067

RFQ COPY

TYPE NAME/ADDRESS HERE

PROPERTY

PROPERTY

HEALTH AND HUMAN RESOURCES
 WELCH COMMUNITY HOSPITAL

454 MCDOWELL STREET
 WELCH, WV
 24801

304-436-8710

DATE PRINTED	TERMS OF SALE	SHIP VIA	FOB	FREIGHT TERMS
12/14/2007				
BID OPENING DATE: 01/23/2008		BID OPENING TIME 01:30PM		

LINE	QUANTITY	UOP	CAT NO	ITEM NUMBER	UNIT PRICE	AMOUNT
<p>THE MODEL/BRAND/SPECIFICATIONS NAMED HEREIN ESTABLISH THE ACCEPTABLE LEVEL OF QUALITY ONLY AND ARE NOT INTENDED TO REFLECT A PREFERENCE OR FAVOR ANY PARTICULAR BRAND OR VENDOR. VENDORS WHO ARE BIDDING ALTERNATES SHOULD SO STATE AND INCLUDE PERTINENT LITERATURE AND SPECIFICATIONS. FAILURE TO PROVIDE INFORMATION FOR ANY ALTERNATES MAY BE GROUNDS FOR REJECTION OF THE BID. THE STATE RESERVES THE RIGHT TO WAIVE MINOR IRREGULARITIES IN BIDS OR SPECIFICATIONS IN ACCORDANCE WITH SECTION 148-1-4 (F) OF THE WEST VIRGINIA LEGISLATIVE RULES AND REGULATIONS.</p> <p>PURCHASING CARD ACCEPTANCE: THE STATE OF WEST VIRGINIA CURRENTLY UTILIZES A VISA PURCHASING CARD PROGRAM WHICH IS ISSUED THROUGH A BANK. THE SUCCESSFUL VENDOR MUST ACCEPT THE STATE OF WEST VIRGINIA VISA PURCHASING CARD FOR PAYMENT OF ALL ORDERS PLACED BY ANY STATE AGENCY AS A CONDITION OF AWARD.</p> <p>VENDOR PREFERENCE CERTIFICATE</p> <p>CERTIFICATION AND APPLICATION* IS HEREBY MADE FOR PREFERENCE IN ACCORDANCE WITH WEST VIRGINIA CODE, 5A-3-37 (DOES NOT APPLY TO CONSTRUCTION CONTRACTS).</p> <p>A. APPLICATION IS MADE FOR 2.5% PREFERENCE FOR THE REASON CHECKED:</p>						

SEE REVERSE SIDE FOR TERMS AND CONDITIONS

SIGNATURE _____ TELEPHONE _____ DATE _____

TITLE _____ FEIN _____ ADDRESS CHANGES TO BE NOTED ABOVE

WHEN RESPONDING TO RFQ, INSERT NAME AND ADDRESS



State of West Virginia
 Department of Administration
 Purchasing Division
 2019 Washington Street East
 Post Office Box 50130
 Charleston, WV 25305-0130

Request for Quotation

RFO NUMBER
WEH80221

PAGE

ADDRESS CORRESPONDENCE TO ATTENTION OF
ROBERTA WAGNER
304-558-0067

RFQ COPY
 TYPE NAME/ADDRESS HERE

HEALTH AND HUMAN RESOURCES
 WELCH COMMUNITY HOSPITAL

 454 MCDOWELL STREET
 WELCH, WV
 24801 304-436-8710

DATE PRINTED	TERMS OF SALE	SHIP VIA	FOB	FREIGHT TERMS
12/14/2007				
BID OPENING DATE: 01/23/2008		BID OPENING TIME 01:30PM		

LINE	QUANTITY	UOP	CAT NO	ITEM NUMBER	UNIT PRICE	AMOUNT
<p>() BIDDER IS AN INDIVIDUAL RESIDENT VENDOR AND HAS RESIDED CONTINUOUSLY IN WEST VIRGINIA FOR FOUR (4) YEARS IMMEDIATELY PRECEDING THE DATE OF THIS CERTIFICATION; OR</p> <p>() BIDDER IS A PARTNERSHIP, ASSOCIATION OR CORPORATION RESIDENT VENDOR AND HAS MAINTAINED ITS HEAD-QUARTERS OR PRINCIPAL PLACE OF BUSINESS CONTINUOUSLY IN WEST VIRGINIA FOR FOUR (4) YEARS IMMEDIATELY PRECEDING THE DATE OF THIS CERTIFICATION; OR 80% OF THE OWNERSHIP INTEREST OF BIDDER IS HELD BY ANOTHER INDIVIDUAL, PARTNERSHIP, ASSOCIATION OR CORPORATION RESIDENT VENDOR WHO HAS MAINTAINED ITS HEADQUARTERS OR PRINCIPAL PLACE OF BUSINESS CONTINUOUSLY IN WEST VIRGINIA FOR FOUR (4) YEARS IMMEDIATELY PRECEDING THE DATE OF THIS CERTIFICATION; OR</p> <p>() BIDDER IS A CORPORATION NONRESIDENT VENDOR WHICH HAS AN AFFILIATE OR SUBSIDIARY WHICH EMPLOYS A MINIMUM OF ONE HUNDRED STATE RESIDENTS AND WHICH HAS MAINTAINED ITS HEADQUARTERS OR PRINCIPAL PLACE OF BUSINESS WITHIN WEST VIRGINIA CONTINUOUSLY FOR THE FOUR (4) YEARS IMMEDIATELY PRECEDING THE DATE OF THIS CERTIFICATION.</p> <p>B. APPLICATION IS MADE FOR 2.5% PREFERENCE FOR THE REASON CHECKED:</p> <p>() BIDDER IS A RESIDENT VENDOR WHO CERTIFIES THAT, DURING THE LIFE OF THE CONTRACT, ON AVERAGE AT LEAST 75% OF THE EMPLOYEES WORKING ON THE PROJECT BEING BID ARE RESIDENTS OF WEST VIRGINIA WHO HAVE RESIDED IN THE STATE CONTINUOUSLY FOR THE TWO YEARS IMMEDIATELY PRECEDING SUBMISSION OF THIS BID;</p> <p>OR</p> <p>() BIDDER IS A NONRESIDENT VENDOR EMPLOYING A</p>						

SEE REVERSE SIDE FOR TERMS AND CONDITIONS			
SIGNATURE	TELEPHONE	DATE	
TITLE	FEIN	ADDRESS CHANGES TO BE NOTED ABOVE	
WHEN RESPONDING TO RFQ, INSERT NAME AND ADDRESS IN SPACE ABOVE LABELED 'VENDOR'			



State of West Virginia
 Department of Administration
 Purchasing Division
 2019 Washington Street East
 Post Office Box 50130
 Charleston, WV 25305-0130

Request for Quotation

RFQ NUMBER
 WEH80221

PAGE
 12

ADDRESS CORRESPONDENCE TO ATTENTION OF
 ROBERTA WAGNER
 304-558-0067

RFQ COPY

TYPE NAME/ADDRESS HERE

HEALTH AND HUMAN RESOURCES
 WELCH COMMUNITY HOSPITAL

454 MCDOWELL STREET
 WELCH, WV

24801

304-436-8710

DATE PRINTED 12/14/2007	TERMS OF SALE	SHIP VIA	FOB	FREIGHT TERMS
BID OPENING DATE: 01/23/2008		BID OPENING TIME 01:30PM		

LINE	QUANTITY	UOP	GAT NO	ITEM NUMBER	UNIT PRICE	AMOUNT
<p>MINIMUM OF ONE HUNDRED STATE RESIDENTS OR IS A NONRESIDENT VENDOR WITH AN AFFILIATE OR SUBSIDIARY WHICH MAINTAINS ITS HEADQUARTERS OR PRINCIPAL PLACE OF BUSINESS WITHIN WEST VIRGINIA EMPLOYING A MINIMUM OF ONE HUNDRED STATE RESIDENTS WHO CERTIFIES THAT, DURING THE LIFE OF THE CONTRACT, ON AVERAGE AT LEAST 75% OF THE EMPLOYEES OR BIDDERS' AFFILIATE'S OR SUBSIDIARY'S EMPLOYEES ARE RESIDENTS OF WEST VIRGINIA WHO HAVE RESIDED IN THE STATE CONTINUOUSLY FOR THE TWO YEARS IMMEDIATELY PRECEDING SUBMISSION OF THIS BID.</p> <p>BIDDER UNDERSTANDS IF THE SECRETARY OF TAX & REVENUE DETERMINES THAT A BIDDER RECEIVING PREFERENCE HAS FAILED TO CONTINUE TO MEET THE REQUIREMENTS FOR SUCH PREFERENCE, THE SECRETARY MAY ORDER THE DIRECTOR OF PURCHASING TO: (A) RESCIND THE CONTRACT OR PURCHASE ORDER ISSUED; OR (B) ASSESS A PENALTY AGAINST SUCH BIDDER IN AN AMOUNT NOT TO EXCEED 5% OF THE BID AMOUNT AND THAT SUCH PENALTY WILL BE PAID TO THE CONTRACTING AGENCY OR DEDUCTED FROM ANY UNPAID BALANCE ON THE CONTRACT OR PURCHASE ORDER.</p> <p>BY SUBMISSION OF THIS CERTIFICATE, BIDDER AGREES TO DISCLOSE ANY REASONABLY REQUESTED INFORMATION TO THE PURCHASING DIVISION AND AUTHORIZES THE DEPARTMENT OF TAX AND REVENUE TO DISCLOSE TO THE DIRECTOR OF PURCHASING APPROPRIATE INFORMATION VERIFYING THAT BIDDER HAS PAID THE REQUIRED BUSINESS TAXES, PROVIDED THAT SUCH INFORMATION DOES NOT CONTAIN THE AMOUNTS OF TAXES PAID NOR ANY OTHER INFORMATION DEEMED BY THE TAX COMMISSIONER TO BE CONFIDENTIAL.</p> <p>UNDER PENALTY OF LAW FOR FALSE SWEARING (WEST VIRGINIA CODE 61-5-3), BIDDER HEREBY CERTIFIES THAT THIS CERTIFICATE IS TRUE AND ACCURATE IN ALL RESPECTS; AND THAT IF A CONTRACT IS ISSUED TO BIDDER AND IF ANYTHING</p>						

SEE REVERSE SIDE FOR TERMS AND CONDITIONS

SIGNATURE	TELEPHONE	DATE
-----------	-----------	------

TITLE	FEIN	ADDRESS CHANGES TO BE NOTED ABOVE
-------	------	-----------------------------------

WHEN RESPONDING TO RFQ INSERT NAME AND ADDRESS IN SPACE ABOVE LABELED WITH



State of West Virginia
 Department of Administration
 Purchasing Division
 2019 Washington Street East
 Post Office Box 50130
 Charleston, WV 25305-0130

Request for Quotation

RFQ NUMBER
WEH80221

PAGE

ADDRESS CORRESPONDENCE TO ATTENTION OF
ROBERTA WAGNER 304-558-0067

RFQ COPY

TYPE NAME/ADDRESS HERE

HEALTH AND HUMAN RESOURCES
 WELCH COMMUNITY HOSPITAL

454 MCDOWELL STREET
 WELCH, WV
 24801 304-436-8710

DATE PRINTED	TERMS OF SALE	SHIP VIA	FOB	FREIGHT TERMS
12/14/2007				
BID OPENING DATE: 01/23/2008		BID OPENING TIME 01:30PM		

LINE	QUANTITY	UOP	CAT NO	ITEM NUMBER	UNIT PRICE	AMOUNT
CONTAINED WITHIN THIS CERTIFICATE CHANGES DURING THE TERM OF THE CONTRACT, BIDDER WILL NOTIFY THE PURCHASING DIVISION IN WRITING IMMEDIATELY.						
BIDDER: -----						
DATE: -----						
SIGNED: -----						
TITLE: -----						
* CHECK ANY COMBINATION OF PREFERENCE CONSIDERATION(S) IN EITHER "A" OR "B", OR BOTH "A" AND "B" WHICH YOU ARE ENTITLED TO RECEIVE. YOU MAY REQUEST UP TO THE MAXIMUM 5% PREFERENCE FOR BOTH "A" AND "B". (REV. 12/00)						
NOTICE						
A SIGNED BID MUST BE SUBMITTED TO:						
DEPARTMENT OF ADMINISTRATION PURCHASING DIVISION BUILDING 15 2019 WASHINGTON STREET, EAST CHARLESTON, WV 25305-0130						
PLEASE NOTE: A CONVENIENCE COPY WOULD BE APPRECIATED.						
THE BID SHOULD CONTAIN THIS INFORMATION ON THE FACE OF THE ENVELOPE OR THE BID MAY NOT BE CONSIDERED:						

SEE REVERSE SIDE FOR TERMS AND CONDITIONS

SIGNATURE	TELEPHONE	DATE
-----------	-----------	------

TITLE	FEIN	ADDRESS CHANGES TO BE NOTED ABOVE
-------	------	-----------------------------------

WHEN RESPONDING TO RFQ, INSERT NAME AND ADDRESS IN SPACE ABOVE LABELLED 'VENDOR'



State of West Virginia
 Department of Administration
 Purchasing Division
 2019 Washington Street East
 Post Office Box 50130
 Charleston, WV 25305-0130

Request for Quotation

BFO NUMBER:
 WEH80221

PAGE
 14

ADDRESS CORRESPONDENCE TO ATTENTION OF
 ROBERTA WAGNER
 304-558-0067

RFQ COPY
 TYPE NAME/ADDRESS HERE

VENDOR

SHIP TO

HEALTH AND HUMAN RESOURCES
 WELCH COMMUNITY HOSPITAL

 454 MCDOWELL STREET
 WELCH, WV
 24801 304-436-8710

DATE PRINTED	TERMS OF SALE	SHIP VIA	F.O.B.	FREIGHT TERMS
12/14/2007				
BID OPENING DATE: 01/23/2008		BID OPENING TIME: 01.30PM		

LINE	QUANTITY	UOP	CAT NO	ITEM NUMBER	UNIT PRICE	AMOUNT
SEALED BID						
BUYER:-----RW/FILE 22-----						
RFQ. NO.:-----WEH80221-----						
BID OPENING DATE:-----1/23/2007-----						
BID OPENING TIME:-----1:30 PM-----						
PLEASE PROVIDE A FAX NUMBER IN CASE IT IS NECESSARY TO CONTACT YOU REGARDING YOUR BID:						

CONTACT PERSON (PLEASE PRINT CLEARLY):						

***** THIS IS THE END OF RFQ WEH80221 ***** TOTAL:						

SEE REVERSE SIDE FOR TERMS AND CONDITIONS

SIGNATURE _____ TELEPHONE _____ DATE _____

TITLE _____ FEIN _____ ADDRESS CHANGES TO BE NOTED ABOVE

WHEN RESPONDING TO RFQ INSERT NAME AND ADDRESS IN SPACE ABOVE LABELS

GENERAL INFORMATION**Purpose:**

The Acquisition and Contract Administration Section of the Purchasing Division "State" for the Department of Health and Human Resources, Bureau for Behavioral Health Facilities, Welch Community Hospital, "Agency" is soliciting Quotations to provide reagents/consumables for chemistry analyzer systems for Welch Community Hospital.

Project:

The mission or purpose of this project is to provide two (2) chemistry analyzers (Dade RXL Max or equal) for the Laboratory at Welch Community Hospital as well as the purchase of necessary reagents/consumables to be used as needed with the vendor-provided chemistry analyzers.

Location

Facility is located in McDowell County at Welch Community Hospital, 454 McDowell Street, Welch WV 24801

PROCUREMENT SPECIFICATIONS**General Requirements**

Vendor is to provide two (2) fully automated chemistry analyzers, (Dade RXL Max or equal) at no additional charge for use with requested reagents/consumables. Vendor is to provide a system that will include a computer, monitor and printer. All equipment will be retained and maintained by the vendor.

Welch Community Hospital desires a Vendor with a proven track record for providing necessary supplies and maintaining of equipment. Vendor must provide three (3) references from clients who have received similar services from the vendor within the past 3 years.

Scope of Work:

Vendor shall provide chemistry analyzer equipment and reagent/consumables as needed for the Laboratory at Welch Community Hospital. Vendor shall include, but not be limited to the following requirements:

1. The equipment must be a single platform that can perform all our test methods.
2. There shall be full mirror image back-up feature so that critical tests have a back-up in the event that an analyzer is down. They must also include a back-up platform for those times when the primary analyzer(s) are not functional.
3. The system must have monitors that notify when STAT tests are completed. It must also monitor the amount of product still available in the equipment to reduce the amount of wasted reagents. The system shall also allow for reagents to be added while maintaining ongoing system operation, eliminating the need for the system to be put in "standby" mode.

WEH80221 Chemistry Analyzers with Reagents

4. Other features shall include; auto repeat of panic values (with values that Hospital can set into the system), and auto dilution of elevated results (Hospital can choose the dilution factor).
5. Vendor must ensure that a local engineer/technician is available to provide service within 2 hours of receiving a service call. Technical support should be available via telephone 24 hours a day/7 days a week to troubleshoot problems and/or answer staff questions.
6. Vendor will ensure hospital's laboratory staff receives proper in-service training whenever there are updates made to the equipment. Preferably, this should be conducted on-site whenever possible.
7. Test kits are to be shipped as requested. Reagents are to be shipped within three (3) days of receiving an order. If shipping costs are involved, clearly state this expense for the instrument delivery as well as for the reagents.
8. Test kits must have a minimum shelf life of ninety (90) days or more beyond date of receipt. Also, the vendor should ensure that each of the reagents delivered to the hospital have the maximum shelf-life available for that specific product.
9. The number of tests requested is for bidding purposes only. The vendor will be required to provide actual quantities needed, be it more or less.
10. Reagents should not have to be mixed before using and be immediately ready to put on the analyzer. Reagents must not need to be frozen or reconstituted-they must be ready to use out of the refrigerator.
11. All products and equipment are to be quoted FOB Destination.

Changes

If changes to the original contract become necessary, a formal contract change order will be negotiated by the State, the Agency and the Vendor, to address changes to the terms and conditions, costs of work included under the contract. An approved contract change order is defined as one approved by the Purchasing Division and approved as to form by the West Virginia Attorney General's Office, encumbered and placed in the U.S. Mail prior to the effective date of such amendment. An approved contract change order is required whenever the change affects the payment provision or the scope of the work. Such changes may be necessitated by new and amended Federal and State regulations and requirements.

As soon as possible after receipt of a written change request from the Agency, but in no event more than thirty (30) days thereafter, the Vendor shall determine if there is an impact on price with the change requested and provide the Agency a written statement to identifying any price impact on the contract or to state that there is no impact. In the event that price will be impacted by the change, the Vendor shall provide a description of the price increase or decrease involved in implementing the requested change.

Invoices, Progress Payments, & Retainage:

The Vendor shall submit invoices, in arrears, to the Agency at the address on the face of the purchase order labeled "Invoice To" pursuant to the terms of the contract. Invoices may not be submitted more than once monthly and State law forbids payment of invoices prior to receipt of services.

Cost Evaluation:

Bid Response must include the cost for the consumables that may be purchased throughout the term of the contract. It shall be understood that the quantities are estimates based on previous testing activity. Estimated quantities shall not constitute an obligation to purchase.

Evaluation will be awarded to the lowest responsible vendor providing the testing equipment and the overall annual cost of reagents and supplies. Only one vendor will be awarded this bid.

The following tests must be performed on one fully automated analyzer.

<u>General Chemistry</u>	<u>TEST Method</u>
Albumin	Dye Binding-Bromcresol Purple
Calcium	Cresolphthalein complexone
Cholesterol	Enzymatic
Creatinine	Kinetic Alkaline Picrate (Jaffe)
Direct Bilirubin	Diazo-Caffeine/Benzoate Coupling
Enzymatic Carbonate	Enzymatic
Glucose (GLU)	Hexokinase
Glucose Gluc (Liquid)	Hexokinase
High-Density Lipoprotein Cholesterol	Non-Pretreat Accelerated Cholesterol Oxidase
Automated HDL Cholesterol	Phosphotungstic Acid/No metal ions w Enzymatic Quantitation
Iron	Ferene without prior protein removal
Automated LDL	Liquid Selective Detergent
Magnesium	Colorimetric Dye Methylthymol Blue
Phosphorus	Phosphomolybdate-UV
Total Bilirubin	Diazo-Caffeine/Benzoate Coupling
Total Iron-Binding Capacity	Alumina Adsorption
IBCT (No Pre-treat)	Ferene
Total Protein	Biuret
Triglycerides	Enzymatic 340nm without serum blank GPDH
Urea Nitrogen	Urease with GLDH (Coupled Enzymes)
Uric Acid	Uricase
<u>Electrolytes</u>	<u>Test Method</u>
Carbon Dioxide	Enzymatic
Chloride	Ion Selective Electrode, Indirect
Potassium	Ion Selective Electrode, Indirect
Sodium	Ion Selective Electrode, Indirect

WEH80221 Chemistry Analyzers with Reagents

EndocrinologyTest Method

*Currently, the hospital uses Dade Behring equipment, thus, some test methods are unique and proprietary to the equipment/company. Please provide your proposed test method that may be specific to the equipment that may be proposed in your bid response.

Hemoglobin A1C	*see above
Thyronine Uptake	*see above
Total Thyroxine	*see above
Triiodothyronine	*see above

EnzymesTest Method

*Currently, the hospital uses Dade Behring equipment, thus, some test methods are unique and proprietary to the equipment/company. Please provide your proposed test method that may be specific to the equipment that may be proposed in your bid response.

Acid Phosphatase	Adapted Thymolphtholein Monophosphate hydrolysis
Alanine Amiotransferase	Adapted Bergmyer methodology
Alkaline PhosphataseAdapted	Bowers and McDomb methodology
Amylase	*see above
Aspartate Aminctranserase	*see above
Creatine Kinase	Modified, Enzymatic Oliver
Creatine Kinase MB Isoenzyme	*see above
Glutamyl Transferase	*see above
Lactic Dehydrogenase	Modified Enzymatic Lactate to Pyruvate Methodology
Lipase	Adapted Clorimetric Neumann
Pseudochclnesterase	Coupled Oxidation reduction-Gal and Roth

Heterogeneous ImmunoassaysTest Method

*Currently, the hospital uses Dade Behring equipment, thus, some test methods are unique and proprietary to the equipment/company. Please provide your proposed test method that may be specific to the equipment that may be proposed in your bid response.

Cardiac Troponin	*see above
Ferritin	*see above
Free PSA	*see above
Free Thyroxine	*see above

WEH80221 Chemistry Analyzers with Reagents

Human Chorionic Gonadotropin Hormone	*see above
Mass CK-MB	*see above
Myoglobin	*see above
NT-PRO BNP	ProBNP Enzymatic Immunoassay Methodology
Tyroid Stimulating Hormone	*see above
Total PSA	*see above

Immunology

Complement C3, Complement C4
 C-Re4Active Protein
 IGA, IGG, IGM
 Transferrin

Test Method

Turbidimetric Assay, Quantitative
 Highly Sensitive, colorimetric Immunoassay
 Quantitative, Turbidimetric Assay
 Quantitative, Turbidimetric Assay

Specialty

Ammonia
 Urine-Cerebrospinal Fluid Protein
 Lactic Acid
 Microalbumin
 Prealbumin

Test Method

Glutamate Dehydrogenase Enzymatic Method
 Pyrogallol Red-molybdate Method
 PETINIA**adapted methodology
 PETINIA technology method

Therapeutic Drug Monitoring**Test Method**

*Currently, the hospital uses Dade Behring equipment, thus, some test methods are unique and proprietary to the equipment/company. Please provide your proposed test method that may be specific to the equipment that may be proposed in your bid response.

Carbamazepine	PETINIA immunoassay methodology
Cyclosporine	*see above
Digoxin	*see above
Digitoxin	*see above
Gentamicine	Enhanced turbidimetric PETINIA
Lidocaine	*see above
Lithium	Non-covalent binary complex methodology
N-Acetylprocainamide	PETINIA methodology
Phenobarbital	PETINIA methodology

WEH80221 Chemistry Analyzers with Reagents

Phenytoin	PETINIA methodology
Procainamide	PETINIA methodology
Sirolimus	*see above
Tarcolimus	*see above
Theophylline	PETINIA methodology
Tobramycin	PETINIA methodology
Vancomycin	PETINIA methodology
Valproic Acid	PETINIA methodology

Toxicology

Acetaminophen
 Ethyl Alcohol
 Salicylate
 Urine Amphetamine Screen
 Urine Barbiturates Screen
 Urine Benzodiazepines Screen
 Urine Cannabinoids Screen
 Urine Cocaine Metabolite Screen
 Urine Methadone Screen
 Urine Opiates Screen
 Urine Phencyclidine Screen

Test Method

Enzymatic hydrolysis methodology
 Modified alcohol dehydrogenase methodology
 Modified Trinder colorimetric
 Syva Emit II Plus methodology
 Syva Emit II Plus methodology
 Syva Emit II Plus methodology
 Syva Emit II Plus methodology
 Syva Emit II Plus methodology
 Syva Emit II Plus methodology
 Syva Emit II Plus methodology
 Syva Emit II Plus methodology

****PETINIA=particle enhanced turbidimetric inhibition immunoassay.**

WEH80221 Chemistry Analyzers with Reagents PRICING BID FOR REAGENTS/SUPPLIES

BID SHEET

Item No.	Estimated Annual Usage	Description	Unit #	Count Per Unit	Unit Price	Estimated Annual Cost
1	26 units	ALB-Albumin	DF13	480 test per unit	\$	\$
2	36 units	BUN-Urea Nitrogen	DF21	480 test per unit	\$	\$
3	34 units	CA-Calcium	DF23A	480 test per unit	\$	\$
4	10 units	CHOL-Cholesterol	DF27	480 test per unit	\$	\$
5	40 units	CREA-Creatinine	DF33A	480 test per unit	\$	\$
6	30 units	ECO2-Enzymatic CO2	DF137	360 test per unit	\$	\$
7	20 units	GLU-Glucose	DF40	960 test per unit	\$	\$
8	10 units	PHOS-Phosphorus	DF61	480 test per unit	\$	\$
9	46 units	TBIL-Total Bilirubin	DF67A	480 test per unit	\$	\$
10	34 units	TProt-Total Protein	DF73	480 test per unit	\$	\$
11	10 units	URCA-Uric Acid	DF77	480 test per unit	\$	\$
12	50 units	ALP-Alkaline Phosphatase	DF15A	360 test per unit	\$	\$
13	10 units	CK-Creatinine Kinase	DF29A	480 test per unit	\$	\$
14	14 units	DBIL-Direct Bilirubin	DF25A	320 test per unit	\$	\$
15	12 units	GGT-Gamma Glutamyl Transferase	DF45A	288 test per unit	\$	\$
16	52 units	AST-Aspartate Aminotransferase	DF41A	360 test per unit	\$	\$
17	72 units	ALT-Alanine Aminotransferase	DF43A	240 test per unit	\$	\$
18	18 units	LDH-Lactic Dehydrogenase	DF53A	480 test per unit	\$	\$
19	17 units	TGL-Triglyceride	DF69A	480 test per unit	\$	\$
20	10 units	ACTM-Acetaminophen	DF88	80 test per unit	\$	\$
21	19 units	ALC-Alcohol	DF18	120 test per unit	\$	\$
22	10 units	AMON-Ammonia	DF19	120 test per unit	\$	\$
23	16 units	AMY-Amylase	DF17A	240 test per unit	\$	\$
24	12 units	CRP-C Reactive Protein	DF37	120 test per unit	\$	\$
25	8 units	IRN-Iron	DF49A	240 test per unit	\$	\$
26	28 units	LIP-Lipase	DF55A	120 test per unit	\$	\$
27	28 units	MG-Magnesium	DF57	120 test per unit	\$	\$
28	10 units	SAL-Salicylate	DF20	120 test per unit	\$	\$
29	16 units	TU-Thyronine Uptake	DF75A	160 test per unit	\$	\$
30	26 units	T4-Thyroxine	DF65	120 test per unit	\$	\$
31	6 units	UCFP-Urine CF Protein	DF26	80 test per unit	\$	\$
32	14 units	CRBM-Carbamazepine	DF87	80 test per unit	\$	\$
33	36 units	DGNA-Digoxin No Pretreat	DF35A	80 test per unit	\$	\$
34	31 units	GENT-Gentamicin	DF12	80 test per unit	\$	\$
35	32 units	PHNO-Phenobarbital	DF60	80 test per unit	\$	\$
36	26 units	PTN-Phenytoin	DF64	112 test per unit	\$	\$
37	28 units	THEO-Theophylline	DF71	80 test per unit	\$	\$
38	16 units	VALP-Valproic Acid	DF78	80 test per unit	\$	\$
39	10 units	VANC-Vancomycin	DF86	80 test per unit	\$	\$
	14 units	FERR-Ferritin	RF440	120 test per unit	\$	\$
41	18 units	HCG-Human Chorionic Gonadotrophin	RF430	120 test per unit	\$	\$
42	40 units	MMB-Mass CKMB	RF420	160 test per unit	\$	\$

WEH80221 Chemistry Analyzers with Reagents PRICING BID FOR REAGENTS/SUPPLIES

BID SHEET

Item No.	Estimated Annual Usage	Description	Unit #	Count Per Unit	Unit Price	Estimated Annual Cost
43	10 units	TPSA-Revised Prostate Specific Antigen	RF451	120 test per unit	\$	\$
44	20 units	TSH-Thyroid Stimulating Hormone	RF412	200 test per unit	\$	\$
45	62 units	CTnl-Troponin I	RF421C	120 test per unit	\$	\$
46	16 units	AHDL-HDL Cholesterol, Automated	DF48A	240 test per unit	\$	\$
47	8 units	IBCT-Iron Binding	DF84	240 test per unit	\$	\$
48	8 units	TRNF-Transferrin	DF103	120 test per unit	\$	\$
49	8 units	AHDL Calibrator	DC48A	2 sets/5 levels unit	\$	\$
50	6 units	ALC Calibrator	DC37	2 sets/4 levels per unit	\$	\$
51	6 units	AMON Calibrator	DC25	2 sets/3 levels per unit	\$	\$
52	16 units	CHEM I Calibrator	DC18A	2 sets/3 levels per unit	\$	\$
53	10 units	CHEM II Calibrator	DC20	2 sets/3 levels per unit	\$	\$
54	6 units	CHOL Calibrator	DC16	2 sets/3 levels per unit	\$	\$
55	4 units	CK Verifier	DC26	2 sets/3 levels per unit	\$	\$
56	6 units	CRP Calibrator	DC30	2 sets/3 levels per unit	\$	\$
57	12 units	DRUG II Calibrator	DC49D	2 sets/5 levels per unit	\$	\$
58	8 units	ECO2 Calibrator	DC137	2 sets/3 levels per unit	\$	\$
59	8 units	Enzyme Verifier	DC19	2 sets/3 levels per unit	\$	\$
60	6 units	FERR Calibrator	RC440	2 sets/5 levels per unit	\$	\$
61	6 units	HCG Calibrator	RC430	2 sets/5 levels per unit	\$	\$
62	6 units	IBCT Calibrator	DC84	2 sets/3 levels per unit	\$	\$
63	4 units	IRN/TIBC Calibrator	DC21	2 sets/3 levels per unit	\$	\$
64	6 units	Lipase Verifer	DC15A	2 sets/3 levels per unit	\$	\$
65	8 units	MMB Calibrator	RC420	2 sets/5 levels per unit	\$	\$
66	12 units	REV Drug Calibrator	DC22B	2 sets/5 levels per unit	\$	\$
67	6 units	SAL Calibrator	DC38	2 sets/3 levels per unit	\$	\$
68	6 units	Special Protein Calibrator	DC51	2 sets/5 levels per unit	\$	\$
69	6 units	T4 Calibrator	DC13	2 sets/5 levels per unit	\$	\$
70	6 units	TBIL/DBIL Calibrator	DC17	2 sets/3 levels per unit	\$	\$
71	6 units	TP/ALB Calibrator	DC31	2 sets/3 levels per unit	\$	\$
72	4 units	T/FP5A Calibrator	RC452	2 sets/5 levels per unit	\$	\$
73	6 units	TU Calibrator	DC14	2 sets/5 levels per unit	\$	\$
74	6 units	Thyroid Calibrator	RC410	2 sets/5 levels per unit	\$	\$
75	6 units	UCFP Calibrator	DC45	2 sets/5 levels per unit	\$	\$
76	12 units	cTnl Calibrator	RC421C	2 sets/5 levels per unit	\$	\$
77	134 units	ABS Absorbance Test	DF79	120 test per unit	\$	\$
78	83 units	Cuvette Cartridge	D828	12,000 test per unit	\$	\$
79	4 units	Enzyme Diluent	ED	10 btle/10 ml per unit	\$	\$
80	24 units	Printer Paper -RxL	D829	6 rolls/80ft per unit	\$	\$
81	4 units	Sample Diluent-SD Plus	SDPlus	2 btle/50 ml per unit	\$	\$
82	15 units	Small Sample Cups	DSC5	1,000 test per unit	\$	\$
83	2 units	Sample Cups with Lids	DSC4	1,000 test per unit	\$	\$
84	26 units	Chem Wash	RD701	1btl/1800 ml per unit	\$	\$
85	4 units	IMT Probe Cleaner	RD704	12btles per unit	\$	\$
86	62 units	Reagent Probe Cleaner	RD702	1 btl/500 ml per unit	\$	\$

BID SHEET

Item No.	Estimated Annual Usage	Description	Unit #	Count Per Unit	Unit Price	Estimated Annual Cost
87	26 units	Rev Heterogenous Mod Vessels	RXV1A	1,000 test per unit	\$	\$
88	16 units	Sample Probe Cleaner	RD703	1 btl/1000 ml per unit	\$	\$
89	8 units	QuickLYTE Dilution Check	S640	3 bags/1000 ml per unit	\$	\$
90	8 units	QuickLYTE Flush Solution	S630	3 bags/1000 ml per unit	\$	\$
91	38 units	QuickLYTE IMT Cartridge	S600	4 cartridges per unit	\$	\$
92	20 units	QuickLYTE Sample Diluent	S635	1 btl/500 ml per unit	\$	\$
93	23 units	QuickLYTE Standard A	S620	3 bags/1000 ml per unit	\$	\$
94	14 units	QuickLYTE Standard B	S625	3 bags/1000 ml per unit	\$	\$
95	12 units	Salt Bridge Solution	D105	3 btle/150 ml per unit	\$	\$
96	6 units	Reagent Probe Tip	715871.505	48000 test per unit	\$	\$
97	12 units	GLUC - Liquid Glucose	DF40	1440 test per unit	\$	\$
98	6 units	LI - Lithium	DF132	80 test per unit	\$	\$
99	4 units	FT4 - Free T4	RF410	120 test per unit	\$	\$
100	32 units	ALDL - Automated LDL Cholesterol	DF131	120 test per unit	\$	\$
101	12 units	ALDL Calibrator	DC131	2 sets/5 levels per unit	\$	\$
Estimated Total Annual Cost						\$

Brand/Model of Chemistry Analyzer: _____

Vendor Name: _____

Vendor must provide three (3) references from clients who have received similar services from the vendor within the past 3 years.

Background:

Welch Community Hospital is a 124 bed hospital, 59 of which are Long Term care beds. Acute care beds include: 8 Intensive care beds; 2 pediatric beds; 10 obstetrical beds and 45 medical/surgical beds. The hospital serves the counties of McDowell, Wyoming and Mingo with a total market population of about 83,000.

The following numbers represent the typical utilization encountered by the outpatient service area of Welch Community Hospital for the 2007 fiscal year:

Emergency Room Patients – 10,441
Observation Visits – 542
Clinic Patients – 25,524
Surgeries – 343
Deliveries – 78
Laboratory Tests – 771,015
Radiology – 15,063
CAT Scans – 2,529
Ultrasound – 1,869
Mammography – 633
Respiratory Tests – 21,402
Electrocardiograms – 4,231
Admissions – 974
 Long Term Care ADC (48 Patients per day) – 94%
 Overall ADC (60 Patients per day) – 66%
Total Patient Days (17,514 Long Term Care and 4,496 Acute Care Days) – 22010

Outpatient Services Provided Are:

Primary Care and Family Practice in a Certified Rural Health Setting
Pediatric Clinic
Newborn Care
Internal Medicine
Surgery
Emergency Room Services
Radiology Services Including:
 Diagnostic
 CAT Scan
 Ultrasound
 Mammography
 MRI
 EKG, Cardiac Doppler Studies, Stress Testing and Respiratory Therapy Services
 Laboratory Services



State of West Virginia
 Department of Administration
 Purchasing Division
 2019 Washington Street East
 Post Office Box 50130
 Charleston, WV 25305-0130

Request for Quotation

RFQ NUMBER
 WEH80234...

PAGE

ADDRESS CORRESPONDENCE TO ATTENTION OF
 ROBERTA WAGNER
 304-558-0067

RFQ COPY

TYPE NAME/ADDRESS HERE

HEALTH AND HUMAN RESOURCES
 WELCH COMMUNITY HOSPITAL

454 MCDOWELL STREET
 WELCH, WV
 24801

304-436-8710

DATE PRINTED	TERMS OF SALE	SHIP VIA	FOB	FREIGHT TERMS
04/18/2008				
BID OPENING DATE: 05/22/2008		BID OPENING TIME 01:30PM		

LINE	QUANTITY	UICP	CAT NO	ITEM NUMBER	UNIT PRICE	AMOUNT
PURCHASING DIVISION BUILDING 15 2019 WASHINGTON STREET, EAST CHARLESTON, WV 25305-0130						
PLEASE NOTE: A CONVENIENCE COPY WOULD BE APPRECIATED.						
THE BID SHOULD CONTAIN THIS INFORMATION ON THE FACE OF THE ENVELOPE OR THE BID MAY NOT BE CONSIDERED:						
SEALED BID						
BUYER: -----RW/FILE 22-----						
RFQ. NO.: -----WEH80234-----						
BID OPENING DATE: -----05/22/2008-----						
BID OPENING TIME: -----1:30 PM-----						
PLEASE PROVIDE A FAX NUMBER IN CASE IT IS NECESSARY TO CONTACT YOU REGARDING YOUR BID:						

CONTACT PERSON (PLEASE PRINT CLEARLY):						

SEE REVERSE SIDE FOR TERMS AND CONDITIONS

SIGNATURE	TELEPHONE	DATE
TITLE	FEIN	ADDRESS CHANGES TO BE NOTED ABOVE

WHEN RESPONDING TO RFQ, INSERT NAME AND ADDRESS IN SPACE ABOVE LABELED 'VENDOR'



State of West Virginia
 Department of Administration
 Purchasing Division
 2019 Washington Street East
 Post Office Box 50130
 Charleston, WV 25305-0130

**Request for
 Quotation**

RFQ NUMBER
 WEH80234

PAGE
 1

ADDRESS CORRESPONDENCE TO ATTENTION OF
 ROBERTA WAGNER
 304-558-0067

RFQ COPY
 TYPE NAME/ADDRESS HERE

HEALTH AND HUMAN RESOURCES
 WELCH COMMUNITY HOSPITAL
 454 MCDOWELL STREET
 WELCH, WV
 24801 304-436-8710

DATE PRINTED	TERMS OF SALE	SHIP VIA	F.O.B.	FREIGHT TERMS
04/18/2008				
BID OPENING DATE: 05/22/2008		BID OPENING TIME 01:30PM		

LINE	QUANTITY	UOP	CAT NO	ITEM NUMBER	UNIT PRICE	AMOUNT
***** THIS IS THE END OF RFQ WEH80234 ***** TOTAL:						

SEE REVERSE SIDE FOR TERMS AND CONDITIONS

SIGNATURE _____ TELEPHONE _____ DATE _____

TITLE _____ FEIN _____ ADDRESS CHANGES TO BE NOTED ABOVE

WHEN RESPONDING TO RFQ, INSERT NAME AND ADDRESS IN SPACE ABOVE LABELED 'VENDOR'

GENERAL INFORMATION
Purpose:

The Acquisition and Contract Administration Section of the Purchasing Division "State" for the Department of Health and Human Resources, Bureau for Behavioral Health Facilities, Welch Community Hospital, "Agency" is soliciting Quotations to provide reagents/consumables for chemistry analyzer systems for Welch Community Hospital. Chemistry analyzers are to be provided by the vendor free of charge in exchange for the purchase of reagents/consumables. The vendor will retain ownership of the analyzers and will maintain the analyzers in working order to allow the facility to use them with the requested reagents/consumables.

Project:

The purpose of this project is to provide two (2) fully automated chemistry analyzers, Dade RXL Max or equal at no additional charge and Welch Community Hospital will purchase the necessary reagents/consumables to operate the chemistry analyzers from the equipment supplier.

OPERATING ENVIRONMENT
Facility Location

McDowell County, Welch Community Hospital, 454 McDowell Street, Welch WV 24801

PROCUREMENT SPECIFICATIONS**General Requirements**

The purpose of this project is to provide two (2) fully automated chemistry analyzers, Dade RXL Max or equal at no additional charge for use with requested reagents/consumables. Selected vendor must provide a system that will include a computer, monitor, printer, and any required accessories which will be retained and maintained by the vendor.

Welch Community Hospital desires a Vendor with a proven track record for providing necessary supplies and maintaining of equipment. Vendor must have provided such services for at least three (3) years.

Vendor should provide references from at least three (3) clients for which they have provided these similar services.

Scope of Work:

The vendor shall provide chemistry analyzer equipment and reagent/consumables as needed for the Laboratory at Welch Community Hospital, more specifically; vendor shall include, but not be limited to the following requirements:

1. The equipment must be a single platform that can perform all our test methods.
 2. There shall be full mirror image back-up feature so that critical tests have a back-up in the event that an analyzer is down. They must also include a back-up platform for those times when the primary analyzer(s) are not functional.
 3. The system must have monitors that notify when STAT tests are completed. It must also monitor the amount of product still available in the equipment to reduce the amount of wasted reagents. The system shall also allow for reagents to be added while maintaining ongoing system operation, eliminating the need for the system to be put in "standby" mode.
-

WEH80234 Reagents and Consumables

4. Other features shall include; auto repeat of panic values (with values that Hospital can set into the system), and auto dilution of elevated results (Hospital can choose the dilution factor).
5. The vendor should ensure that a local engineer/technician is available to provide service within 12 hours of receiving a service call, within 24 hours on nights, weekends, and holidays. Also, Technical support should be available via telephone 24 hours a day/7 days a week to troubleshoot problems and/or answer staff questions.
6. The vendor will ensure hospital's laboratory staff receives proper in-service training whenever there are updates made to the equipment. Preferably this should be conducted on site whenever possible.
7. Test kits are to be shipped as requested. Reagents are to be shipped within three (3) days of receiving an order.
8. Test kits must have a minimum shelf life of ninety (90) days or more beyond date of receipt. Also, the vendor should ensure that each of the reagents delivered to the hospital have the maximum shelf life available for that specific product.
9. ~~The number of tests requested is for bidding purposes only. The vendor will be required to provide actual quantities needed, be it more or less.~~
10. Reagents should not have to be mixed before using and be immediately ready to put on the analyzer. Reagents must not need to be frozen or reconstituted-they must be ready to use out of the refrigerator.
11. All products and equipment are to be quoted FOB Destination, unless otherwise stated in vendor's quotation.

Term of Contract

Life of contract shall be for the period of five years with the option of two (2) one (1) year renewals.

Invoices, Progress Payments, & Retainage:

The Vendor shall submit invoices, in arrears, to the Agency at the address on the face of the purchase order labeled "Invoice To" pursuant to the terms of the contract. Invoices may not be submitted more than once monthly and State law forbids payment of invoices prior to receipt of services.

Cost Evaluation:

Bid Response must include the cost for EACH lab test as well as the cost for the consumables that may be purchased throughout the term of the contract. It shall be understood that the quantities are estimates based on previous activity and are not binding. ~~Supplies shall be provided as ordered~~ regardless of the actual quantities ordered, whether more or less.

Evaluation will be based on the overall lowest price of each lab test and the estimated annual usage of consumables.

It is preferred that each responder use the Cost Proposal Sheet provided.

Vendor references may be requested.

WEH80234 Reagents and Consumables

The following tests must be performed on one fully automated analyzer.

General Chemistry**TEST Method**

Albumin	Dye Binding-Bromocresol Purple
Calcium	Cresolphthalein complexone
Cholesterol	Enzymatic
Creatinine	Kinestic Alkaline Picrate (Jaffe)
Direct Bilirubin	Diazo-Caffeine/Benzoate Coupling
Enzymatic Carbonate	Enzymatic

Glucose (GLU)**Hexokinase**

Glucose Gluc (Liquid)	Hexokinase
High-Density Lipoprotein Cholesterol	Non-Pre-treat Accelerated Cholesterol Oxidase
Automated HDL Cholesterol	Phosphotungstic Acid/No metal ions w Enzymatic Quantitation
Iron	Ferene without prior protein removal
Automated LDL	Liquid Selective Detergent
Magnesium	Colorimetric Dye Methylthymol Blue
Phosphorus	Phosphomolybdate-UV
Total Bilirubin	Diazo-Caffeine/Benzoate Coupling
Total Iron-Binding Capacity	Alumina Adsorption
IBCT (No Pre-treat)	Ferene

Total Protein	Biuret
Triglycerides	Enzymatic 340nm without serum blank GPDH
Urea Nitrogen	Urease with GLDH (Coupled Enzymes)
Uric Acid	Uricase

Electrolytes**Test Method****Carbon Dioxide****Enzymatic****Chloride****Ion Selective Electrode, Indirect**

WEH80234 Reagents and Consumables

Potassium	Ion Selective Electrode, Indirect
Sodium	Ion Selective Electrode, Indirect

Endocrinology**Test Method**

*Currently, the hospital uses Dade Behring equipment, thus, some test methods are unique and proprietary to the equipment/company. Please provide your proposed test method that may be specific to the equipment that may be proposed in you bid response.

Hemoglobin A1C	*see above
Thyronine Uptake	*see above
Total Thyroxine	*see above
Triiodothyronine	*see above

Enzymes**Test Method**

*Currently, the hospital uses Dade Behring equipment, thus, some test methods are unique and proprietary to the equipment/company. Please provide your proposed test method that may be specific to the equipment that may be proposed in you bid response.

Acid Phosphatase	Adapted Thymolphtholein Monophosphate hydrolysis
Alanine Amiotransferase	Adapted Bergmyer methodology
Alkaline PhosphataseAdapted	Bowers and McDomb methodology
Amylase	*see above
Aspartate Aminctranserase	*see above
Creatine Kinase	Modified, Enzymatic Oliver
Creatine Kinase MB Isoenzyme	*see above
Glutanyl Transferase	*see above

Lactic Dehydrogenase

Modified Enzymatic Lactate to
Pyruvate Methodology**Enzymes-cont'd****Test Method**

Lipase	Adapted Clorimetric Neumann
Pseudochclnesterase	Coupled Oxidation reduction-Gal and Roth

Heterogeneous Immunoassays**Test Method**

*Currently, the hospital uses Dade Behring equipment, thus, some test methods are unique and proprietary to the equipment/company. Please provide your proposed test method that may be specific to the equipment that may be proposed in you bid response.

WEH80234 Reagents and Consumables

Cardiac Troponin	*see above
Ferritin	*see above
Free PSA	*see above
Free Thyroxine	*see above
Human Chorionic Gonadotropin Hormone	*see above
Mass CK-MB	*see above
Myoglobin	*see above
NT-PRO BNP	ProBNP Enzymatic Immunoassay Methodology
Thyroid Stimulating Hormone	*see above

Total PSA	*see above
-----------	------------

Immunology**Test Method**

Complement C3, Complement C4	Turbidimetric Assay, Quantitative
C-Reactive Protein	Highly Sensitive, colorimetric Immunoassay
IGA, IGG, IGM	Quantitative, Turbidimetric Assay
Transferrin	Quantitative, Turbidimetric Assay

Specialty**Test Method**

Ammonia	Glutamate Dehydrogenase Enzymatic Method
Urine-Cerebrospinal Fluid Protein	Pyrogallol Red-molybdate Method

Lactic Acid
Specialty-cont'd

Test Method

Microalbumin	PETINIA**adapted methodology
--------------	------------------------------

Prealbumin	PETINIA technology method
------------	---------------------------

Therapeutic Drug Monitoring**Test Method**

*Currently, the hospital uses Dade Behring equipment, thus, some test methods are unique and proprietary to the equipment/company. Please provide your proposed test method that may be specific to the equipment that may be proposed in your bid response.

Carbamazepine	PETINIA immunoassay methodology
---------------	---------------------------------

Cyclosporine	*see above
--------------	------------

Digoxin	*see above
---------	------------

WEH80234 Reagents and Consumables

Digitoxin	*see above
Gentamicine	Enhanced turbidimetric PETINIA
Lidocaine	*see above
Lithium	Non-covalent binary complex methodology
N-Acetylprocainamide	PETINIA methodology
Phenobarbital	PETINIA methodology
Phenytoin	PETINIA methodology
Procainamide	PETINIA methodology
Tarcolimus	*see above
Theophylline	PETINIA methodology
Tobramycine	PETINIA methodology
Vancomycin	PETINIA methodology
Valproic Acid	PETINIA methodology
<u>Toxicology</u>	<u>Test Method</u>
Acetaminophen	Enzymatic hydrolysis methodology
<u>Toxicology-cont'd</u>	<u>Test Method</u>
Ethyl Alcohol	Modified alcohol dehydrogenase methodology
Salicylate	Modified Trinder colorimetric
Urine Amphetamine Screen	Syva Emit II Plus methodology
Urine Barbiturates Screen	Syva Emit II Plus methodology
Urine Benzodiazepines Screen	Syva Emit II Plus methodology
Urine Cannabinoids Screen	Syva Emit II Plus methodology
Urine Cocaine Metabolite Screen	Syva Emit II Plus methodology
Urine Methadone Screen	Syva Emit II Plus methodology
Urine Opiates Screen	Syva Emit II Plus methodology
Urine Phencyclidine Screen	Syva Emit II Plus methodology

WEH80234 Reagents and Consumables

****PETINIA=particle enhanced turbidimetric inhibition immunoassay.**

WEH80234 Reagents and Consumables BID SCHEDULE/COST PROPOSAL

BID SCHEDULE/COST PROPOSAL

Item No.	Estimated Annual Usage	Description	Unit #	Count Per Unit	Unit Price	Estimated Annual Cost
1	26 units	ALB-Albumin	DF13	480 test per unit		
2	36 units	BUN-Urea Nitrogen	DF21	480 test per unit		
3	34 units	CA-Calcium	DF23A	480 test per unit		
4	10 units	CHOL-Cholesterol	DF27	480 test per unit		
5	40 units	CREA-Creatinine	DF33A	480 test per unit		
6	30 units	ECO2-Enzymatic CO2	DF137	360 test per unit		
7	20 units	GLU-Glucose	DF40	960 test per unit		
8	10 units	PHOS-Phosphorus	DF61	480 test per unit		
9	46 units	TBIL-Total Bilirubin	DF67A	480 test per unit		
10	34 units	TPROT-Total Protein	DF73	480 test per unit		
11	10 units	URCA-Uric Acid	DF77	480 test per unit		
12	50 units	ALP-Alkaline Phosphatase	DF15A	360 test per unit		
13	40 units	CK-Creatinine Kinase	DF29A	480 test per unit		
14	14 units	DBIL-Direct Bilirubin	DF25A	320 test per unit		
15	12 units	GGT-Gamma Glutamyl Transferase	DF45A	288 test per unit		
16	52 units	AST-Aspartate Aminotransferase	DF41A	360 test per unit		
17	72 units	ALT-Alanine Aminotransferase	DF43A	240 test per unit		
18	18 units	LDH-Lactic Dehydrogenase	DF53A	480 test per unit		
19	17 units	TGL-Triglyceride	DF69A	480 test per unit		
20	10 units	ACTM-Acetaminophen	DF88	80 test per unit		
21	19 units	ALC-Alcohol	DF18	120 test per unit		
22	10 units	AMON-Ammonia	DF19	120 test per unit		
23	16 units	AMY-Amylase	DF17A	240 test per unit		
24	12 units	CRP-C Reactive Protein	DF37	120 test per unit		
25	8 units	IRN-Iron	DF49A	240 test per unit		
26	28 units	LIP-Lipase	DF55A	120 test per unit		
27	28 units	MG-Magnesium	DF57	120 test per unit		
28	10 units	SAL-Salicylate	DF20	120 test per unit		
29	16 units	TU-Thyronine Uptake	DF75A	160 test per unit		
30	26 units	T4-Thyroxine	DF65	120 test per unit		
31	6 units	UCFP-Urine CF Protein	DF26	80 test per unit		
32	14 units	CRBM-Carbamazepine	DF87	80 test per unit		
33	36 units	DGNA-Digoxin-No Pretreat	DF35A	80 test per unit		
34	31 units	GENT-Gentamicin	DF12	80 test per unit		
35	32 units	PHNO-Phenobarbital	DF60	80 test per unit		
36	26 units	PTN-Phenytoin	DF64	112 test per unit		
37	28 units	THEO-Theophylline	DF71	80 test per unit		
38	16 units	VALP-Valproic Acid	DF78	80 test per unit		
39	10 units	VANC-Vancomycin	DF86	80 test per unit		
40	14 units	FERR-Ferritin	RF440	120 test per unit		
41	18 units	HCG-Human Chorionic Gonadotrophin	RF430	120 test per unit		
42	40 units	MMB-Mass CKMB	RF420	160 test per unit		
43	10 units	TPSA-Revised Prostate Specific Antigen	RF451	120 test per unit		
44	20 units	TSH-Thyroid Stimulating Hormone	RF412	200 test per unit		
45	62 units	CTnl-Troponin I	RF421C	120 test per unit		
46	16 units	AHDL-HDL Cholesterol, Automated	DF48A	240 test per unit		

WEH80234 Reagents and Consumables BID SCHEDULE/COST PROPOSAL

BID SCHEDULE/COST PROPOSAL

Item No.	Estimated Annual Usage	Description	Unit #	Count Per Unit	Unit Price	Estimated Annual Cost
47	8 units	IBCT-Iron Binding	DF84	240 test per unit		
48	8 units	TRNF-Transferrin	DF103	120 test per unit		
49	8 units	AHDL Calibrator	DC48A	2 sets/5 levels unit		
50	6 units	ALC Calibrator	DC37	2 sets/4 levels per unit		
51	6 units	AMON Calibrator	DC25	2 sets/3 levels per unit		
52	16 units	CHEM I Calibrator	DC18A	2 sets/3 levels per unit		
53	10 units	CHEM II Calibrator	DC20	2 sets/3 levels per unit		
54	6 units	CHOL Calibrator	DC16	2 sets/3 levels per unit		
55	4 units	CK Verifier	DC28	2 sets/3 levels per unit		
56	6 units	CRP Calibrator	DC30	2 sets/3 levels per unit		
57	12 units	DRUG II Calibrator	DC49D	2 sets/5 levels per unit		
58	8 units	ECO2 Calibrator	DC137	2 sets/3 levels per unit		
59	8 units	Enzyme Verifier	DC19	2 sets/3 levels per unit		
60	6 units	FERR Calibrator	RC440	2 sets/5 levels per unit		
61	6 units	HCG Calibrator	RC430	2 sets/5 levels per unit		
62	6 units	IBCT Calibrator	DC84	2 sets/3 levels per unit		
63	4 units	IRN/TIBC Calibrator	DC21	2 sets/3 levels per unit		
64	6 units	Lipase Verifier	DC15A	2 sets/3 levels per unit		
65	8 units	MMB Calibrator	RC420	2 sets/5 levels per unit		
66	12 units	REV Drug Calibrator	DC22B	2 sets/5 levels per unit		
67	6 units	SAL Calibrator	DC38	2 sets/3 levels per unit		
68	6 units	Special Protein Calibrator	DC51	2 sets/5 levels per unit		
69	6 units	T4 Calibrator	DC13	2 sets/5 levels per unit		
70	6 units	TBIL/DBIL Calibrator	DC17	2 sets/3 levels per unit		
71	6 units	TP/ALB Calibrator	DC31	2 sets/3 levels per unit		
72	4 units	T/FPISA Calibrator	RC452	2 sets/5 levels per unit		
73	6 units	TU Calibrator	DC14	2 sets/5 levels per unit		
74	6 units	Thyroid Calibrator	RC410	2 sets/5 levels per unit		
75	6 units	UCFP Calibrator	DC45	2 sets/5 levels per unit		
76	12 units	cTnI Calibrator	RC421C	2 sets/5 levels per unit		
77	134 units	ABS Absorbance Test	DF79	120 test per unit		
78	83 units	Cuvette Cartridge	D828	12,000 test per unit		
79	4 units	Enzyme Diluent	ED	10 btl/10 ml per unit		
80	24 units	Printer Paper - Pxl	D829	6 rolls/80ft per unit		
81	4 units	Sample Diluent-SD Plus	SDPlus	2 btl/50 ml per unit		
82	15 units	Small Sample Cups	DSC5	1,000 test per unit		
83	2 units	Sample Cups with Lids	DSC4	1,000 test per unit		
84	26 units	Chem Wash	RD701	1btl/1800 ml per unit		
85	4 units	IMT Probe Cleaner	RD704	12btles per unit		
86	62 units	Reagent Probe Cleaner	RD702	1 btl/500 ml per unit		
87	26 units	Rev Heterogenous Mod Vessels	RXV1A	1,000 test per unit		
88	16 units	Sample Probe Cleaner	RD703	1 btl/1000 ml per unit		
89	8 units	QuickLYTE Dilution Check	S640	3 bags/1000 ml per unit		
90	8 units	QuickLYTE Flush Solution	S630	3 bags/1000 ml per unit		
91	38 units	QuickLYTE IMT Cartridge	S600	4 cartridges per unit		
92	20 units	QuickLYTE Sample Diluent	S635	1 btl/500 ml per unit		

WEH80234 Reagents and Consumables BACKGROUND

Background:

Welch Community Hospital is a 124 bed hospital, 59 of which are Long Term care beds. Acute care beds include: 8 Intensive care beds; 2 pediatric beds; 10 obstetrical beds and 45 medical/surgical beds. The hospital serves the counties of McDowell, Wyoming and Mingo with a total market population of about 83,000.

The following numbers represent the typical utilization encountered by the outpatient service area of Welch Community Hospital for the 2007 fiscal year:

Emergency Room Patients – 10,441
 Observation Visits – 542
 Clinic Patients – 25,524
 Surgeries – 343
 Deliveries – 78
 Laboratory Tests – 771,015
 Radiology – 15,063
 CAT Scans – 2,529
 Ultrasound – 1,869
 Mammography – 633
 Respiratory Tests – 21,402
 Electrocardiograms – 4,231
 Admissions – 974
 Long Term Card ADC (48 Patients per day) – 94%
 Overall ADC (60 Patients per day) – 66%
 Total Patient Days (17,514 Long Term Care and 4,496 Acute Care Days) – 22010

Outpatient Services Provided Are:

Primary Care and Family Practice in a Certified Rural Health Setting
 Pediatric Clinic
 Newborn Care
 Internal Medicine
 Surgery
 Emergency Room Services
 Radiology Services Including:
 Diagnostic
 CAT Scan
 Ultrasound
 Mammography
 MRI
 EKG, Cardiac Doppler Studies, Stress Testing and Respiratory Therapy Services
 Laboratory Services

WEH80234 Reagents and Consumables BID SCHEDULE/COST PROPOSAL

BID SCHEDULE/COST PROPOSAL						
Item No.	Estimated Annual Usage	Description	Unit #	Count Per Unit	Unit Price	Estimated Annual Cost
93	23 units	QuickLYTE Standard A	S620	3 bags/1000 ml per unit		
94	14 units	QuickLYTE Standard B	S625	3 bags/1000 ml per unit		
95	12 units	Salt Bridge Solution	D105	3 btle/150 ml per unit		
96	6 units	Reagent Probe Tip	715871.505	48,000 test per unit		
97	12 units	GLUC - Liquid Glucose	DF40	1440 test per unit		
98	6 units	LI - Lithium	DF132	80 test per unit		
99	4 units	FT4 - Free T4	RF410	120 test per unit		
100	32 units	ALDL - Automated LDL Cholesterol	DF131	120 test per unit		
101	12 units	ALDL Calibrator	DC131	2 sets/5 levels per unit		
Total Estimated Annual Cost for the Reagents/Consumables =						
Price Per Lab Test Procedure Performed \$						x Estimated Quantity 100,000 = Total
Total of Reagents/Consumables + Total of Lab Test Costs						

The attached Form WV-96 Agreement Addendum is used when a vendor includes terms and conditions which may conflict with the West Virginia State Code.

ATTACHMENT
P.O.# WE#80234

This agreement constitutes the entire agreement between the parties, and there are no other terms and conditions applicable to the licenses granted hereunder.

Agreed

Signature Date

Title

Company Name

Signature Date

Title

Agency/Division

Dimension® RxL Max® clinical chemistry system with Heterogeneous Immunoassay Module Instrument Specifications

Effective: December 2008

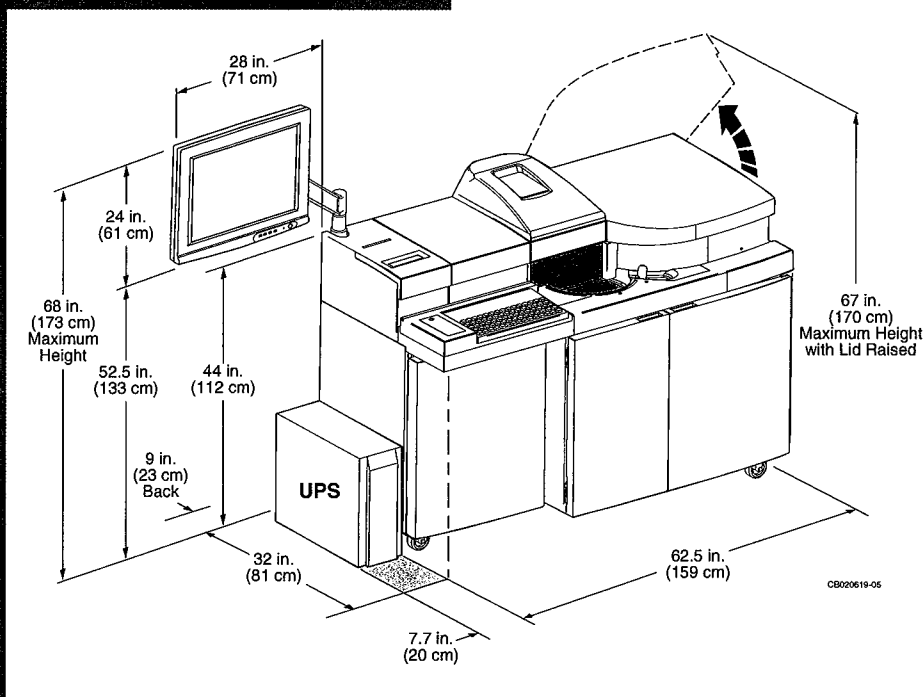

Instrument Weight and Dimensions

Weight

880 lbs. (400 kg)

Dimensions

62.5 in. (159 cm)¹ wide x 44 in. (112 cm) high without monitor; 68 in. (173 cm)² high with monitor x 32 in. (81 cm)³ deep

Additional Instrument Clearances (Minimum)

- Monitor overhead clearance—19 in. (48 cm)
- Monitor left side clearance—16 in. (41 cm)
- Cooling fan clearance on right side—3 in. (8 cm)
- Ventilation clearance in back—9 in. (23 cm)
- Doorway opening for installation—32 in. (81 cm)

Notes: No leveling required; however, the two front casters should be locked during system operation.

A 360° access is needed for service. Installation and service require at least 36 in. (91 cm) of working space on each side. Access to back of instrument requires moving it forward.

UPS must be installed in same room as instrument. UPS should be installed on left side of instrument (when viewed from front); if installed in back, allow 11 in. (28 cm) of clearance.

The instrument keyboard can be raised to reduce the depth from 32 in. (81 cm) to 30.5 in. (77 cm) for moving the instrument through doorways.

1. Add 7.7 in. (20 cm) to the length if the UPS is positioned to the left of the instrument.
2. Required for raising instrument lids.
3. Add 11 in. (28 cm) to the depth if the UPS is positioned behind the instrument.

SIEMENS

Room Environment

Operating Temperature

Room temperature must be 65–85°F (17–30°C) with a maximum fluctuation of 5°F (2.8°C) per hour. The system requires a maximum of 120 minutes to warm up from a cold start to the incubation temperature.

Relative Humidity

Maintain between 20% and 80%

Average Thermal Output

4778 Btu/hr for each instrument

Average Noise Output

< 70 dBA at 1 m while operating

Water Requirements

- Instrument feed water: must maintain stable dO₂ content between 5 and 8 ppm
- Consumption 1.0–1.1 gal./hr (4.0–4.5 L/hr) maximum throughput
- Temperature: < 35°C
- Resistivity: ≥ 10 megohms cm
- Bacterial content: ≤ 10 colony-forming units/mL
- System feed water line must not exceed 12 feet
- System is supplied with water system

Waste Requirements

Liquid Waste Output

1.0–1.1 gal./hr (4.0–4.5 L/hr) at maximum throughput

Liquid wastes are aspirated from all instrument sources to the Dimension® RxL Max® waste bottle. The waste is considered biohazardous, consisting of condensate, probe wash water and reagent.

A 50-ft (15.2-m) tubing is supplied for external waste disposal. Maintenance of the waste tubing from the instrument to the disposal point is the responsibility of the user. The disposal point should be selected in accordance with local hazardous waste guidelines.

Electrical Installation Requirements

Current/Operating Power Requirements

	Nominal Line Voltage VAC	Line Voltage VAC	Nominal Line Frequency HZ	Maximum Continuous Current AMPS	Power Consumption (WATTS)
RxL Max® with HM	115	103 to 127	47 to 63	13	1900
	230	207 to 253	47 to 63	8	1900

Recommended Service Outlet

115 vac, 60 Hz, Single Phase, 20 A (North America)

230 vac, 50 Hz, Single Phase, 16A (EU)*

*230 vac/13A for U.K.

Transient Overvoltage

Installation Category II (branch circuit)

Circuit

The instrument should have a separate, dedicated line with Hot, Neutral, and Isolated Ground in its own conduit. The conduit should start at the distribution panel and be continuous to the receptacle. Three-wire distribution to the receptacle is required for each instrument. The third (green) ground wire should start at the distribution panel and be continuous to the receptacle in accordance with NEC paragraph 250.146(D), unless local codes prohibit. The ground wire should not be tied to grounds from other loads.

Leakage Current

	115 vac/60 Hz	230 vac/50 Hz
Normal Supply Connections	Under 10 µA	Under 100 µA
Ground Disconnected	Under 70 µA	Under 150 µA
Measurement Standard	UL3101-1	EN61010-1

This complies with the requirement of UL 3101-1, CSA C22.2 No. 1010.1 and TUVS Certification for EN 61010-1 safety standards for non-patient vicinity laboratory equipment.

Wire Size

10 AWG wire is required to minimize the voltage drop between the distribution panel and the receptacle when each instrument operates at full current load.

Receptacle

Customer must provide a Hospital Grade receptacle, installed by a qualified electrician before arrival of the instrument. The receptacle must be accessible to the 9-ft. (2.7 m) power cord furnished with the instrument.

The USA requires NEMA #5-20R 20 amp straight blade receptacle (Hubbell receptacle No. IG-8310 or equivalent.)

Phone Line Requirements

A dedicated phone line connected to the Dimension® RxL Max® with HM is required for installation.

- Dedicated, direct line connected only to the Dimension® RxL Max® with HM (not connected through a switchboard)
- Full duplex—capable of two-way transmission
- Standard phone connection (not digital)
- RJ11C or RJ11W phone jack

Host Interfacing

A 25-pin female connector is required for hookup to the male connector used for host communications port.

Installation

The Dimension® RxL Max® with HM will be installed by a qualified Siemens Healthcare Diagnostics Inc. representative. The installation will include checkout of all aspects necessary to ensure the equipment is fully operational.

Preventive Maintenance Frequency

Four Siemens service preventive maintenance visits per year.

Code Compliance

Safety Compliance

The Dimension® RxL Max® with HM system has been designed and tested to comply with safety standards UL3101-1, CSA C22.2#1010.1 and EN61010-1 under the following environmental conditions [subclause 1.4]:

Temperature	5°C (41°F) to 40°C (104°F)
Humidity	Maximum 80% at 31°C to 50% at 40°C
Altitude	Maximum 2,000 m (6,562 ft)
Main Supply	115±10% vac or 230±10% vac, 50/60Hz
Overvoltage Category	Category II, connected to a branch circuit
Pollution degree	Degree 2, normal indoor laboratory environment. Air contains only non-conductive pollutants with occasional condensation.

Additional *functional* environmental conditions are discussed earlier in this document.

Emission Compliance

The Dimension® RxL Max® with HM system has been designed and tested to CISPR 22 Class A. In a domestic environment it may cause radio interference, in which case you may need to take measures to mitigate the interference.

The Dimension® RxL Max® with HM system should not be used next to any Industrial Scientific and Medical (ISM) equipment that must functionally produce RF energy (e.g., diathermy equipment).

Barcode Scanner

The barcode scanner uses Class I LEDs (light-emitting diodes) and is not hazardous to your eyes.