



State of West Virginia
 Department of Administration
 Purchasing Division
 2019 Washington Street East
 Post Office Box 50130
 Charleston, WV 25305-0130

Request for Quotation

RFQ NUMBER
 PSH90126

PAGE
 1

ADDRESS CORRESPONDENCE TO ATTENTION OF:
 ROBERTA WAGNER
 304-558-0067

VENDOR

*119161134 304-925-0338
 LONGS SECURITY CAMERA SYSTEMS
 102 38TH ST SE
 CHARLESTON WV 25304

SHIP TO

HEALTH AND HUMAN RESOURCES
 PINECREST HOSPITAL
 105 SOUTH EISENHOWER DRIVE
 BECKLEY, WV 25801 304-256-6614

DATE PRINTED	TERMS OF SALE	SHIP VIA	F.O.B.	FREIGHT TERMS
04/16/2009				

BID OPENING DATE: 05/26/2009 BID OPENING TIME 01:30PM

LINE	QUANTITY	UOP	CAT NO	ITEM NUMBER	UNIT PRICE	AMOUNT
0001	5	EA		936-73		
<p>***** DRUG FREE WORKPLACE CONFORMANCE AFFIDAVIT AND THE BID BOND MUST BE RECEIVED WITH THE BID SUBMISSION. ***** MANDATORY PRE-BID MEETING IS SCHEDULED FOR 5/5/9 AT 11:00 AM AT PINECREST HOSPITAL, 105 S. EISENHOWER DRIVE BECKLEY, WV, ROOM #B-109. *****</p> <p>DIGITAL VIDEO RECORDERS PER SPECIFICATIONS</p> <p>TO PROVIDE ALL LABOR, MATERIALS, EQUIPMENT AND OTHER INCIDENTALS RELATED TO THE INSTALLATION OF A NEW SECURITY CAMERA SYSTEM TO BE INSTALLED AT PINECREST HOSPITAL LOCATED AT 105 S. EISENHOWER DRIVE, BECKLEY, WV, 25801, PER THE ATTACHED SPECIFICATIONS.</p> <p>THIS IS A REBID OF PSH90063. INQUIRIES: WRITTEN QUESTIONS SHALL BE ACCEPTED THROUGH CLOSE OF BUSINESS ON 5/7/2009. QUESTIONS MAY BE SENT VIA USPS, FAX, COURIER OR E-MAIL. IN ORDER TO ASSURE NO VENDOR RECEIVES AN UNFAIR ADVANTAGE, NO SUBSTANTIVE QUESTIONS WILL BE ANSWERED ORALLY. IF POSSIBLE, E-MAIL QUESTIONS ARE PREFERRED. ADDRESS INQUIRIES TO: ROBERTA WAGNER</p>						

RECEIVED
 2009 JUN 10 A 12:47
 PURCHASING DIVISION
 STATE OF WV

SEE REVERSE SIDE FOR TERMS AND CONDITIONS

SIGNATURE: *Alan C. Long* TELEPHONE: 304-925-0338 DATE: 6-9-09

TITLE: *Owner* ADDRESS CHANGES TO BE NOTED ABOVE

FEIN: 20-3881880

WHEN RESPONDING TO RFQ, INSERT NAME AND ADDRESS IN SPACE ABOVE LABELED 'VENDOR'

GENERAL TERMS & CONDITIONS
REQUEST FOR QUOTATION (RFQ) AND REQUEST FOR PROPOSAL (RFP)

1. Awards will be made in the best interest of the State of West Virginia.
2. The State may accept or reject in part, or in whole, any bid.
3. All quotations are governed by the *West Virginia Code* and the *Legislative Rules* of the Purchasing Division.
4. Prior to any award, the apparent successful vendor must be properly registered with the Purchasing Division and have paid the required \$125 fee.
5. All services performed or goods delivered under State Purchase Order/Contracts are to be continued for the term of the Purchase Order/Contracts, contingent upon funds being appropriated by the Legislature or otherwise being made available. In the event funds are not appropriated or otherwise available for these services or goods, this Purchase Order/Contract becomes void and of no effect after June 30.
6. Payment may only be made after the delivery and acceptance of goods or services.
7. Interest may be paid for late payment in accordance with the *West Virginia Code*.
8. Vendor preference will be granted upon written request in accordance with the *West Virginia Code*.
9. The State of West Virginia is exempt from federal and state taxes and will not pay or reimburse such taxes.
10. The Director of Purchasing may cancel any Purchase Order/Contract upon 30 days written notice to the seller.
11. The laws of the State of West Virginia and the *Legislative Rules* of the Purchasing Division shall govern all rights and duties under the Contract, including without limitation the validity of this Purchase Order/Contract.
12. Any reference to automatic renewal is hereby deleted. The Contract may be renewed only upon mutual written agreement of the parties.
13. **BANKRUPTCY:** In the event the vendor/contractor files for bankruptcy protection, this Contract may be deemed null and void, and terminated without further order.
14. **HIPAA BUSINESS ASSOCIATE ADDENDUM:** The West Virginia State Government HIPAA Business Associate Addendum (BAA), approved by the Attorney General, and available online at the Purchasing Division's web site (<http://www.state.wv.us/admin/purchase/vrc/hipaa.htm>) is hereby made part of the agreement. Provided that, the Agency meets the definition of a Cover Entity (45 CFR §160.103) and will be disclosing Protected Health Information (45 CFR §160.103) to the vendor.
15. **WEST VIRGINIA ALCOHOL & DRUG-FREE WORKPLACE ACT:** If this Contract constitutes a public improvement construction contract as set forth in Article 1D, Chapter 21 of the West Virginia Code ("The West Virginia Alcohol and Drug-Free Workplace Act"), then the following language shall hereby become part of this Contract: "The contractor and its subcontractors shall implement and maintain a written drug-free workplace policy in compliance with the West Virginia Alcohol and Drug-Free Workplace Act, as set forth in Article 1D, Chapter 21 of the West Virginia Code. The contractor and its subcontractors shall provide a sworn statement in writing, under the penalties of perjury, that they maintain a valid drug-free work place policy in compliance with the West Virginia and Drug-Free Workplace Act. It is understood and agreed that this Contract shall be cancelled by the awarding authority if the Contractor: 1) Fails to implement its drug-free workplace policy; 2) Fails to provide information regarding implementation of the contractor's drug-free workplace policy at the request of the public authority; or 3) Provides to the public authority false information regarding the contractor's drug-free workplace policy."

INSTRUCTIONS TO BIDDERS

1. Use the quotation forms provided by the Purchasing Division.
2. **SPECIFICATIONS:** Items offered must be in compliance with the specifications. Any deviation from the specifications must be clearly indicated by the bidder. Alternates offered by the bidder as **EQUAL** to the specifications must be clearly defined. A bidder offering an alternate should attach complete specifications and literature to the bid. The Purchasing Division may waive minor deviations to specifications.
3. Complete all sections of the quotation form.
4. Unit prices shall prevail in case of discrepancy.
5. All quotations are considered F.O.B. destination unless alternate shipping terms are clearly identified in the quotation.
6. **BID SUBMISSION:** All quotations must be delivered by the bidder to the office listed below prior to the date and time of the bid opening. Failure of the bidder to deliver the quotations on time will result in bid disqualifications: Department of Administration, Purchasing Division, 2019 Washington Street East, P.O. Box 50130, Charleston, WV 25305-0130



State of West Virginia
 Department of Administration
 Purchasing Division
 2019 Washington Street East
 Post Office Box 50130
 Charleston, WV 25305-0130

Request for Quotation

RFQ NUMBER
PSH90126

PAGE
2

ADDRESS CORRESPONDENCE TO ATTENTION OF:
ROBERTA WAGNER 304-558-0067

VENDOR

*119161134 304-925-0338
 LONGS SECURITY CAMERA SYSTEMS
 102 38TH ST SE
 CHARLESTON WV 25304

SHIP TO

HEALTH AND HUMAN RESOURCES
 PINECREST HOSPITAL
 105 SOUTH EISENHOWER DRIVE
 BECKLEY, WV 25801 304-256-6614

DATE PRINTED	TERMS OF SALE	SHIP VIA	F.O.B	FREIGHT TERMS
--------------	---------------	----------	-------	---------------

BID OPENING DATE: 04/16/2009 05/26/2009 BID OPENING TIME: 01:30PM

LINE	QUANTITY	UOP	CAT. NO.	ITEM NUMBER	UNIT PRICE	AMOUNT
DEPARTMENT OF ADMINISTRATION PURCHASING DIVISION 2019 WASHINGTON STREET, EAST CHARLESTON, WV 25311 FAX: 304-558-4112 E-MAIL: ROBERTA.A.WAGNER@WV.GOV						
THE MODEL/BRAND/SPECIFICATIONS NAMED HEREIN ESTABLISH THE ACCEPTABLE LEVEL OF QUALITY ONLY AND ARE NOT INTENDED TO REFLECT A PREFERENCE OR FAVOR ANY PARTICULAR BRAND OR VENDOR. VENDORS WHO ARE BIDDING ALTERNATES SHOULD SO STATE AND INCLUDE PERTINENT LITERATURE AND SPECIFICATIONS. FAILURE TO PROVIDE INFORMATION FOR ANY ALTERNATES MAY BE GROUNDS FOR REJECTION OF THE BID. THE STATE RESERVES THE RIGHT TO WAIVE MINOR IRREGULARITIES IN BIDS OR SPECIFICATIONS IN ACCORDANCE WITH SECTION 148-1-4(F) OF THE WEST VIRGINIA LEGISLATIVE RULES AND REGULATIONS. EXHIBIT 5						
WEST VIRGINIA CODE 21-1D-5 PROVIDES THAT: ANY SOLICITATION FOR A PUBLIC IMPROVEMENT CONSTRUCTION CONTRACT REQUIRES EACH VENDOR THAT SUBMITS A BID FOR THE WORK TO SUBMIT AT THE SAME TIME AN AFFIDAVIT OF COMPLIANCE WITH THE BID. THE ENCLOSED PURCHASING AFFIDAVIT MUST BE SIGNED AND SUBMITTED WITH THE BID AS EVIDENCE OF THE VENDOR'S COMPLIANCE WITH THE PROVISIONS OF ARTICLE 1D, CHAPTER 21 OF THE WEST VIRGINIA CODE. FAILURE TO SUBMIT THE SIGNED PURCHASING AFFIDAVIT WITH THE BID SHALL RESULT IN DISQUALIFICATION OF SUCH BID.						
NOTICE TO PROCEED: THIS CONTRACT IS TO BE PERFORMED						

SIGNATURE		TELEPHONE	DATE
TITLE	FEIN	ADDRESS CHANGES TO BE NOTED ABOVE	

WHEN RESPONDING TO RFQ, INSERT NAME AND ADDRESS IN SPACE ABOVE LABELED 'VENDOR'



State of West Virginia
 Department of Administration
 Purchasing Division
 2019 Washington Street East
 Post Office Box 50130
 Charleston, WV 25305-0130

Request for Quotation

RFQ NUMBER
PSH90126

PAGE
3

ADDRESS CORRESPONDENCE TO ATTENTION OF
ROBERTA WAGNER 304-558-0067

VENDOR

*119161134 304-925-0338
 LONGS SECURITY CAMERA SYSTEMS
 102 38TH ST SE
 CHARLESTON WV 25304

SHIP TO

HEALTH AND HUMAN RESOURCES
 PINECREST HOSPITAL
 105 SOUTH EISENHOWER DRIVE
 BECKLEY, WV 25801 304-256-6614

DATE PRINTED	TERMS OF SALE	SHIP VIA	F.O.B.	FREIGHT TERMS
04/16/2009				

BID OPENING DATE: 05/26/2009 BID OPENING TIME: 01:30PM

LINE	QUANTITY	UOP	CAT NO	ITEM NUMBER	UNIT PRICE	AMOUNT
<p>WITHIN 120 CALENDAR DAYS AFTER THE NOTICE TO PROCEED IS RECEIVED.</p> <p>CANCELLATION: THE DIRECTOR OF PURCHASING RESERVES THE RIGHT TO CANCEL THIS CONTRACT IMMEDIATELY UPON WRITTEN NOTICE TO THE VENDOR IF THE MATERIALS OR WORKMANSHIP SUPPLIED ARE OF AN INFERIOR QUALITY OR DO NOT CONFORM WITH THE SPECIFICATIONS OF THE BID AND CONTRACT HERE IN.</p> <p>WAGE RATES: THE CONTRACTOR OR SUBCONTRACTOR SHALL PAY THE HIGHER OF THE U.S. DEPARTMENT OF LABOR MINIMUM WAGE RATES AS ESTABLISHED FOR RALEIGH COUNTY, PURSUANT TO WEST VIRGINIA CODE 21-5A, ET, SEQ. (PREVAILING WAGE RATES APPLY TO THIS PROJECT)</p> <p>ARBITRATION: ANY REFERENCES MADE TO ARBITRATION OR INTEREST FOR PAYMENTS DUE (EXCEPT FOR ANY INTEREST REQUIRED BY STATE LAW) CONTAINED IN THIS CONTRACT OR IN ANY AMERICAN INSTITUTE OF ARCHITECTS DOCUMENTS PERTAINING TO THIS CONTRACT ARE HEREBY DELETED.</p> <p>WORKERS' COMPENSATION: VENDOR IS REQUIRED TO PROVIDE A CERTIFICATE FROM WORKERS' COMPENSATION IF SUCCESSFUL.</p> <p>ALL OF THE ITEMS CHECKED BELOW WILL BE A REQUIREMENT OF THIS CONTRACT:</p> <p>(XX) INSURANCE: SUCCESSFUL VENDOR SHALL FURNISH PROOF OF COMMERCIAL GENERAL LIABILITY INSURANCE PRIOR TO ISSUANCE OF CONTRACT. UNLESS OTHERWISE SPECIFIED IN THE BID DOCUMENTS, THE MINIMUM AMOUNT OF INSURANCE COVERAGE REQUIRED IS \$250,000.</p>						

JEL

SEE REVERSE SIDE FOR TERMS AND CONDITIONS

SIGNATURE	TELEPHONE	DATE
TITLE	FEIN	ADDRESS CHANGES TO BE NOTED ABOVE

WHEN RESPONDING TO RFQ, INSERT NAME AND ADDRESS IN SPACE ABOVE LABELED 'VENDOR'



State of West Virginia
 Department of Administration
 Purchasing Division
 2019 Washington Street East
 Post Office Box 50130
 Charleston, WV 25305-0130

Request for Quotation

RFQ NUMBER
PSH90126

PAGE
4

ADDRESS CORRESPONDENCE TO ATTENTION OF:
ROBERTA WAGNER 304-558-0067

VENDOR

*119161134 304-925-0338
 LONGS SECURITY CAMERA SYSTEMS
 102 38TH ST SE
 CHARLESTON WV 25304

SHIP TO

HEALTH AND HUMAN RESOURCES
 PINECREST HOSPITAL
 105 SOUTH EISENHOWER DRIVE
 BECKLEY, WV 25801 304-256-6614

DATE PRINTED	TERMS OF SALE	SHIP VIA	F.O.B.	FREIGHT TERMS
04/16/2009				

BID OPENING DATE: 05/26/2009 BID OPENING TIME 01:30PM

LINE	QUANTITY	UQP	CAT NO	ITEM NUMBER	UNIT PRICE	AMOUNT
<p>() BUILDERS RISK INSURANCE: SUCCESSFUL VENDOR SHALL FURNISH PROOF OF BUILDERS RISK - ALL RISK INSURANCE IN AN AMOUNT EQUAL TO 100% OF THE AMOUNT OF THE CONTRACT.</p> <p>(XX) BONDS: FIVE PERCENT (5%) OF THE TOTAL AMOUNT OF THE BID PAYABLE TO THE STATE OF WEST VIRGINIA, SHALL BE SUBMITTED WITH EACH BID AS A BID BOND. THE SUCCESSFUL BIDDER SHALL ALSO FURNISH A PERFORMANCE BOND AND LABOR/MATERIAL BOND FOR 100% OF THE AMOUNT OF THE CONTRACT. BONDS MAY BE PROVIDED IN THE FORM OF A CERTIFIED CHECK, IRREVOCABLE LETTER OF CREDIT, OR BOND FURNISHED BY A SOLVENT SURETY COMPANY AUTHORIZED TO DO BUSINESS IN THE STATE OF WEST VIRGINIA. A LETTER OF CREDIT SUBMITTED IN LIEU OF A BOND WILL ONLY BE ALLOWED FOR PROJECTS UNDER \$100,000. PERSONAL OR BUSINESS CHECKS ARE NOT ACCEPTABLE IN LIEU OF THE 5% BID BOND, PERFORMANCE BOND, OR LABOR AND MATERIAL BOND.</p> <p>() MAINTENANCE BOND: A TWO (2) YEAR MAINTENANCE BOND COVERING THE ROOFING SYSTEM WILL BE A REQUIREMENT OF THE SUCCESSFUL VENDOR.</p> <p>REV. 11/00</p> <p>EXHIBIT 7</p> <p>DOMESTIC ALUMINUM, GLASS & STEEL IN PUBLIC WORKS PROJECTS</p> <p>IN ACCORDANCE WITH WEST VIRGINIA CODE 5-19-1 ET., SEQ., EVERY CONTRACT FOR CONSTRUCTION, RECONSTRUCTION, ALTERATION, REPAIR, IMPROVEMENT OR MAINTENANCE OF PUBLIC WORKS, WHERE THE COST IS MORE THAN \$50,000 AND, IN THE CASE OF STEEL ONLY, WHERE THE COST OF STEEL IS MORE THAN \$50,000 OR WHERE MORE THAN 10,000 POUNDS OF</p>						

AEL

SEE REVERSE SIDE FOR TERMS AND CONDITIONS

SIGNATURE	TELEPHONE	DATE
-----------	-----------	------

TITLE	FEIN	ADDRESS CHANGES TO BE NOTED ABOVE
-------	------	-----------------------------------

WHEN RESPONDING TO RFQ, INSERT NAME AND ADDRESS IN SPACE ABOVE LABELED 'VENDOR'



State of West Virginia
 Department of Administration
 Purchasing Division
 2019 Washington Street East
 Post Office Box 50130
 Charleston, WV 25305-0130

Request for Quotation

RFQ NUMBER
PSH90126

PAGE
5

ADDRESS CORRESPONDENCE TO ATTENTION OF:
ROBERTA WAGNER 304-558-0067

*119161134 304-925-0338
 LONGS SECURITY CAMERA SYSTEMS
 102 38TH ST SE
 CHARLESTON WV 25304

HEALTH AND HUMAN RESOURCES
 PINECREST HOSPITAL
 105 SOUTH EISENHOWER DRIVE
 BECKLEY, WV 25801 304-256-6614

DATE PRINTED	TERMS OF SALE	SHIP VIA	F.O.B.	FREIGHT TERMS
04/16/2009				

BID OPENING DATE: 05/26/2009 BID OPENING TIME 01:30PM

LINE	QUANTITY	UOP	CAT NO.	ITEM NUMBER	UNIT PRICE	AMOUNT
<p>STEEL ARE REQUIRED, THE STATE WILL ACCEPT ONLY ALUMINUM GLASS, OR STEEL PRODUCTS PRODUCED IN THE UNITED STATES. IN ADDITION, ITEMS OF MACHINERY OR EQUIPMENT PURCHASED FOR USE AT THE SITE OF PUBLIC WORKS SHALL BE MADE OF DOMESTIC ALUMINUM, GLASS OR STEEL, UNLESS THE COST OF THE PRODUCT IS LESS THAN \$50,000 OR LESS THAN 10,000 POUNDS OF STEEL ARE USED IN PUBLIC WORKS PROJECTS.</p> <p>FOREIGN MADE ALUMINUM, GLASS OR STEEL PRODUCTS MAY BE ACCEPTED ONLY IF THE COST OF DOMESTIC PRODUCTS IS FOUND TO BE UNREASONABLE. SUCH COST IS UNREASONABLE IF IT IS 20% OR MORE HIGHER THAN THE BID PRICE FOR FOREIGN MADE PRODUCTS. IF THE DOMESTIC ALUMINUM, GLASS OR STEEL PRODUCTS TO BE SUPPLIED OR PRODUCED IN A "SUBSTANTIAL LABOR SURPLUS AREA", AS DEFINED BY THE UNITED STATES DEPARTMENT OF LABOR, FOREIGN PRODUCTS MAY BE SUPPLIED ONLY IF DOMESTIC PRODUCTS ARE 30% OR MORE HIGHER IN PRICE THAN THE FOREIGN MADE PRODUCTS.</p> <p>IF, PRIOR TO THE AWARD OF A CONTRACT UNDER THE ABOVE PROVISIONS, THE SPENDING OFFICER OF THE SPENDING UNIT DETERMINES THAT THERE EXISTS A BID FOR LIKE FOREIGN ALUMINUM, GLASS OR STEEL THAT IS REASONABLE AND LOWER THAN THE LOWEST BID DOMESTIC PRODUCTS, THE SPENDING OFFICE MAY REQUEST, IN WRITING, A REEVALUATION AND REDUCTION IN THE LOWEST BID FOR SUCH DOMESTIC PRODUCTS. ALL VENDORS MUST INDICATE IN THEIR BID IF THEY ARE SUPPLYING FOREIGN ALUMINUM, GLASS OR STEEL.</p> <p>REV. 3/88</p> <p>EXHIBIT 9</p> <p>NOTICE FOR ISSUANCE & ACKNOWLEDGEMENT OF CONSTRUCTION PROJECT ADDENDA</p>						

SIGNATURE			TELEPHONE		DATE
TITLE	FEIN	ADDRESS CHANGES TO BE NOTED ABOVE			

WHEN RESPONDING TO RFQ, INSERT NAME AND ADDRESS IN SPACE ABOVE LABELED 'VENDOR'



State of West Virginia
 Department of Administration
 Purchasing Division
 2019 Washington Street East
 Post Office Box 50130
 Charleston, WV 25305-0130

Request for Quotation

RFQ NUMBER
 PSH90126

PAGE
 6

ADDRESS CORRESPONDENCE TO ATTENTION OF
 ROBERTA WAGNER
 304-558-0067

VENDOR

*119161134 304-925-0338
 LONGS SECURITY CAMERA SYSTEMS
 102 38TH ST SE
 CHARLESTON WV 25304

SHIP TO

HEALTH AND HUMAN RESOURCES
 PINECREST HOSPITAL
 105 SOUTH EISENHOWER DRIVE
 BECKLEY, WV
 25801 304-256-6614

DATE PRINTED	TERMS OF SALE	SHIP VIA	F.O.B.	FREIGHT TERMS
04/16/2009				

BID OPENING DATE: 05/26/2009 BID OPENING TIME 01:30PM

LINE	QUANTITY	UOP	CAT NO.	ITEM NUMBER	UNIT PRICE	AMOUNT
<p>THE ARCHITECT/ENGINEER AND/OR AGENCY SHALL BE REQUIRED TO ABIDE BY THE FOLLOWING SCHEDULE IN ISSUING CONSTRUCTION PROJECT ADDENDA FOR STATE AGENCIES:</p> <p>(1) THE ARCHITECT/ENGINEER SHALL PREPARE THE ADDENDUM AND A LIST OF ALL PARTIES THAT HAVE PROCURED DRAWINGS AND SPECIFICATIONS FOR THE PROJECT. THE ADDENDUM AND LIST SHALL BE FORWARDED TO THE BUYER IN THE STATE PURCHASING DIVISION. THE ARCHITECT/ENGINEER SHALL ALSO SEND A COPY OF THE ADDENDUM TO THE STATE AGENCY FOR WHICH THE CONTRACT IS ISSUED.</p> <p>(2) THE BUYER SHALL SEND THE ADDENDUM TO ALL INTERESTED PARTIES AND, IF NECESSARY, EXTEND THE BID OPENING DATE. ANY ADDENDUM SHOULD BE RECEIVED BY THE BUYER WITHIN FOURTEEN (14) DAYS PRIOR TO THE BID OPENING DATE.</p> <p>(3) ALL ADDENDA SHOULD BE FORMALLY ACKNOWLEDGED BY ALL BIDDERS AND SUBMITTED TO THE STATE PURCHASING DIVISION. THE SAME RULES AND REGULATIONS THAT APPLY TO THE ORIGINAL BIDDING DOCUMENT SHALL ALSO APPLY TO AN ADDENDUM DOCUMENT. THE ONLY EXCEPTION MAY BE FOR AN ADDENDUM THAT IS ISSUED FOR THE SOLE PURPOSE OF CHANGING A BID OPENING TIME AND/OR DATE.</p> <p>REV. 11/96</p> <p>EXHIBIT 10</p> <p>ADDENDUM ACKNOWLEDGEMENT</p> <p>I HEREBY ACKNOWLEDGE RECEIPT OF THE FOLLOWING CHECKED</p>						

SEE REVERSE SIDE FOR TERMS AND CONDITIONS

SIGNATURE	TELEPHONE	DATE
TITLE	FEIN	ADDRESS CHANGES TO BE NOTED ABOVE

WHEN RESPONDING TO RFQ, INSERT NAME AND ADDRESS IN SPACE ABOVE LABELED 'VENDOR'



State of West Virginia
 Department of Administration
 Purchasing Division
 2019 Washington Street East
 Post Office Box 50130
 Charleston, WV 25305-0130

Request for Quotation

RFQ NUMBER
 PSH90126

PAGE
 7

ADDRESS CORRESPONDENCE TO ATTENTION OF:
 ROBERTA WAGNER
 304-558-0067

VENDOR

*119161134 304-925-0338
 LONGS SECURITY CAMERA SYSTEMS
 102 38TH ST SE
 CHARLESTON WV 25304

SHIP TO

HEALTH AND HUMAN RESOURCES
 PINECREST HOSPITAL
 105 SOUTH EISENHOWER DRIVE
 BECKLEY, WV 25801 304-256-6614

DATE PRINTED	TERMS OF SALE	SHIP VIA	F.O.B.	FREIGHT TERMS
04/16/2009				

BID OPENING DATE: 05/26/2009 BID OPENING TIME 01:30PM

LINE	QUANTITY	UOP	CAT NO	ITEM NUMBER	UNIT PRICE	AMOUNT
ADDENDUM(S) AND HAVE MADE THE NECESSARY REVISIONS TO MY PROPOSAL, PLANS AND/OR SPECIFICATION, ETC. ADDENDUM NOS. : NO. 1 ✓ NO. 2 ✓ NO. 3 ✓ NO. 4 NO. 5						
I UNDERSTAND THAT FAILURE TO CONFIRM THE RECEIPT OF THE ADDENDUM(S) MAY BE CAUSE FOR REJECTION OF THE BIDS. VENDOR MUST CLEARLY UNDERSTAND THAT ANY VERBAL REPRESENTATION MADE OR ASSUMED TO BE MADE DURING ANY ORAL DISCUSSION HELD BETWEEN VENDOR'S REPRESENTATIVES AND ANY STATE PERSONNEL IS NOT BINDING. ONLY THE INFORMATION ISSUED IN WRITING AND ADDED TO THE SPECIFICATIONS BY AN OFFICIAL ADDENDUM IS BINDING.						
SIGNATURE Longs Security Camera Sys. LLCCOMPANY06-09-09DATE						
REV. 11/96						
CONTRACTORS LICENSE SEE REVERSE SIDE FOR TERMS AND CONDITIONS						

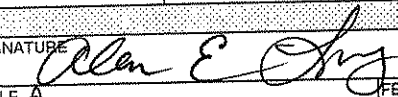
SIGNATURE  TELEPHONE 304-925-0338 DATE 06-09-09
 TITLE Owner FEIN 20-3081880 ADDRESS CHANGES TO BE NOTED ABOVE

WHEN RESPONDING TO RFQ, INSERT NAME AND ADDRESS IN SPACE ABOVE LABELED 'VENDOR'



State of West Virginia
 Department of Administration
 Purchasing Division
 2019 Washington Street East
 Post Office Box 50130
 Charleston, WV 25305-0130

Request for Quotation

RFQ NUMBER
 PSH90126

PAGE
 8

ADDRESS CORRESPONDENCE TO ATTENTION OF:
 ROBERTA WAGNER
 304-558-0067

*119161134 304-925-0338
 LONGS SECURITY CAMERA SYSTEMS
 102 38TH ST SE
 CHARLESTON WV 25304

HEALTH AND HUMAN RESOURCES
 PINECREST HOSPITAL
 105 SOUTH EISENHOWER DRIVE
 BECKLEY, WV 25801 304-256-6614

DATE PRINTED	TERMS OF SALE	SHIP VIA	F.O.B.	FREIGHT TERMS
04/16/2009				
BID OPENING DATE		BID OPENING TIME		01:30PM

LINE	QUANTITY	UOP	CAT. NO.	ITEM NUMBER	UNIT PRICE	AMOUNT
<p>WEST VIRGINIA STATE CODE 21-11-2 REQUIRES THAT ALL PERSONS DESIRING TO PERFORM CONTRACTING WORK IN THIS STATE MUST BE LICENSED. THE WEST VIRGINIA CONTRACTORS LICENSING BOARD IS EMPOWERED TO ISSUE THE CONTRACTORS LICENSE. APPLICATIONS FOR A CONTRACTORS LICENSE MAY BE MADE BY CONTACTING THE WEST VIRGINIA DIVISION OF LABOR CAPITOL COMPLEX, BUILDING 3, ROOM 319, CHARLESTON, WV 25305. TELEPHONE: (304) 558-7890.</p> <p>WEST VIRGINIA STATE CODE 21-11-11 REQUIRES ANY PROSPECTIVE BIDDER TO INCLUDE THE CONTRACTORS LICENSE NUMBER ON THEIR BID.</p> <p>BIDDER TO COMPLETE: CONTRACTORS NAME: <i>Longs' Security Camera Systems' LLC</i> CONTRACTORS LICENSE NO.: <i>WV040102</i></p> <p>THE SUCCESSFUL BIDDER WILL BE REQUIRED TO FURNISH A COPY OF THEIR CONTRACTORS LICENSE PRIOR TO ISSUANCE OF A PURCHASE ORDER/CONTRACT</p> <p>APPLICABLE LAW</p> <p>THE WEST VIRGINIA STATE CODE, PURCHASING DIVISION RULES AND REGULATIONS, AND THE INFORMATION PROVIDED IN THE "REQUEST FOR QUOTATION" ISSUED BY THE PURCHASING DIVISION IS THE SOLE AUTHORITY GOVERNING THIS PROCUREMENT.</p> <p>ANY INFORMATION PROVIDED IN SPECIFICATION MANUALS, OR ANY OTHER SOURCE, VERBAL OR WRITTEN, WHICH CONTRADICTS OR ALTERS THE INFORMATION PROVIDED FROM THE SOURCES AS DESCRIBED IN THE ABOVE PARAGRAPH IS VOID AND OF NO</p>						

SEE REVERSE SIDE FOR TERMS AND CONDITIONS

SIGNATURE	TELEPHONE	DATE
TITLE	FEIN	ADDRESS CHANGES TO BE NOTED ABOVE

WHEN RESPONDING TO RFQ, INSERT NAME AND ADDRESS IN SPACE ABOVE LABELED 'VENDOR'



State of West Virginia
 Department of Administration
 Purchasing Division
 2019 Washington Street East
 Post Office Box 50130
 Charleston, WV 25305-0130

Request for Quotation

RFQ NUMBER
PSH90126

PAGE
9

ADDRESS CORRESPONDENCE TO ATTENTION OF
ROBERTA WAGNER 304-558-0067

VENDOR

*119161134 304-925-0338
 LONGS SECURITY CAMERA SYSTEMS
 102 38TH ST SE
 CHARLESTON WV 25304

SHIP TO

HEALTH AND HUMAN RESOURCES
 PINECREST HOSPITAL
 105 SOUTH EISENHOWER DRIVE
 BECKLEY, WV 25801 304-256-6614

DATE PRINTED	TERMS OF SALE	SHIP VIA	F.O.B.	FREIGHT TERMS
04/16/2009				
BID OPENING DATE: 05/26/2009		BID OPENING TIME 01:30PM		

LINE	QUANTITY	UOP	CAT NO	ITEM NUMBER	UNIT PRICE	AMOUNT
EFFECT.						
BANKRUPTCY: IN THE EVENT THE VENDOR/CONTRACTOR FILES FOR BANKRUPTCY PROTECTION, THIS CONTRACT IS AUTOMATICALLY NULL AND VOID, AND IS TERMINATED WITHOUT FURTHER ORDER.						
REV. 1/2005						
NOTICE						
A SIGNED BID MUST BE SUBMITTED TO:						
DEPARTMENT OF ADMINISTRATION PURCHASING DIVISION BUILDING 15 2019 WASHINGTON STREET, EAST CHARLESTON, WV 25305-0130						
PLEASE NOTE: A CONVENIENCE COPY WOULD BE APPRECIATED. THE BID SHOULD CONTAIN THIS INFORMATION ON THE FACE OF THE ENVELOPE OR THE BID MAY NOT BE CONSIDERED:						
SEALED BID						
BUYER: -----RW/FILE 22-----						
REQ. NO.: -----PSH90126-----						
BID OPENING DATE: -----05/26/2009-----						
BID OPENING TIME: -----1:30 PM-----						
PLEASE PROVIDE A FAX NUMBER IN CASE IT IS NECESSARY TO CONTACT YOU REGARDING YOUR BID:						

SEE REVERSE SIDE FOR TERMS AND CONDITIONS

SIGNATURE	TELEPHONE	DATE
<i>Alan E. Day</i>	304-925-2367	06-09-09
TITLE	FEIN	ADDRESS CHANGES TO BE NOTED ABOVE
Owner	20-3881880	

WHEN RESPONDING TO RFQ, INSERT NAME AND ADDRESS IN SPACE ABOVE LABELED 'VENDOR'



State of West Virginia
 Department of Administration
 Purchasing Division
 2019 Washington Street East
 Post Office Box 50130
 Charleston, WV 25305-0130

Request for Quotation

RFQ NUMBER
PSH90126

PAGE
1

ADDRESS CORRESPONDENCE TO ATTENTION OF:
ROBERTA WAGNER
304-558-0067

VENDOR
 *119161134 304-925-0338
LONGS SECURITY CAMERA SYSTEMS
102 38TH ST SE
CHARLESTON WV 25304

SHIP TO
HEALTH AND HUMAN RESOURCES
PINECREST HOSPITAL
105 SOUTH EISENHOWER DRIVE
BECKLEY, WV
25801 **304-256-6614**

DATE PRINTED 05/13/2009	TERMS OF SALE	SHIP VIA	F.O.B.	FREIGHT TERMS
-----------------------------------	---------------	----------	--------	---------------

BID OPENING DATE: **05/26/2009** **BID OPENING TIME 01:30PM**

LINE	QUANTITY	UOP	CAT NO.	ITEM NUMBER	UNIT PRICE	AMOUNT
<p>ADDENDUM NO. 1</p> <p>1. QUESTIONS AND ANSWERS ARE ATTACHED.</p> <p>2. ADDENDUM ACKNOWLEDGEMENT IS ATTACHED. THIS DOCUMENT SHOULD BE SIGNED AND RETURNED WITH YOUR BID. FAILURE TO SIGN AND RETURN MAY RESULT IN DISQUALIFICATION OF YOUR BID.</p> <p>EXHIBIT 10</p> <p>REQUISITION NO.: PSH90126</p> <p>ADDENDUM ACKNOWLEDGEMENT</p> <p>I HEREBY ACKNOWLEDGE RECEIPT OF THE FOLLOWING CHECKED ADDENDUM(S) AND HAVE MADE THE NECESSARY REVISIONS TO MY PROPOSAL, PLANS AND/OR SPECIFICATION, ETC.</p> <p>ADDENDUM NO. S: NO. 1 ✓ NO. 2 ✓ NO. 3 ✓ NO. 4 NO. 5 I UNDERSTAND THAT FAILURE TO CONFIRM THE RECEIPT OF THE ADDENDUM(S) MAY BE CAUSE FOR REJECTION OF BIDS.</p>						

SEE REVERSE SIDE FOR TERMS AND CONDITIONS

SIGNATURE: *Allen E. Long* TELEPHONE: **304-925-0338** DATE: **06-09-09**

TITLE: *Owner* FEIN: **20-3881080** ADDRESS CHANGES TO BE NOTED ABOVE

WHEN RESPONDING TO RFQ, INSERT NAME AND ADDRESS IN SPACE ABOVE LABELED 'VENDOR'



State of West Virginia
 Department of Administration
 Purchasing Division
 2019 Washington Street East
 Post Office Box 50130
 Charleston, WV 25305-0130

Request for Quotation

RFQ NUMBER
PSH90126

PAGE
2

ADDRESS CORRESPONDENCE TO ATTENTION OF:
ROBERTA WAGNER
304-558-0067

VENDOR

RFQ COPY
 TYPE NAME/ADDRESS HERE

SHIP TO

HEALTH AND HUMAN RESOURCES
 PINECREST HOSPITAL
 105 SOUTH EISENHOWER DRIVE
 BECKLEY, WV
 25801 304-256-6614

DATE PRINTED	TERMS OF SALE	SHIP VIA	F.O.B.	FREIGHT TERMS
05/13/2009				

BID OPENING DATE: 05/26/2009 BID OPENING TIME 01:30PM

LINE	QUANTITY	UOP	CAT NO.	ITEM NUMBER	UNIT PRICE	AMOUNT
------	----------	-----	---------	-------------	------------	--------

VENDOR MUST CLEARLY UNDERSTAND THAT ANY VERBAL REPRESENTATION MADE OR ASSUMED TO BE MADE DURING ANY ORAL DISCUSSION HELD BETWEEN VENDOR'S REPRESENTATIVES AND ANY STATE PERSONNEL IS NOT BINDING. ONLY THE INFORMATION ISSUED IN WRITING AND ADDED TO THE SPECIFICATIONS BY AN OFFICIAL ADDENDUM IS BINDING.

Alan Long
 SIGNATURE

Long's Security Camera Systems, LLC
 COMPANY

06-09-09
 DATE

REV. 11/96

END OF ADDENDUM NO. 1

0001	5	EA		936-73	\$2,470.00	\$12,350.00
DIGITAL VIDEO RECORDERS PER SPECIFICATIONS						

SEE REVERSE SIDE FOR TERMS AND CONDITIONS

SIGNATURE	TELEPHONE	DATE
TITLE	FEIN	ADDRESS CHANGES TO BE NOTED ABOVE

WHEN RESPONDING TO RFQ, INSERT NAME AND ADDRESS IN SPACE ABOVE LABELED 'VENDOR'



State of West Virginia
 Department of Administration
 Purchasing Division
 2019 Washington Street East
 Post Office Box 50130
 Charleston, WV 25305-0130

Request for Quotation

RFQ NUMBER
 PSH90126

PAGE
 3

ADDRESS CORRESPONDENCE TO ATTENTION OF:
 ROBERTA WAGNER
 304-558-0067

VENDOR

RFQ COPY
 TYPE NAME/ADDRESS HERE

SHIP TO

HEALTH AND HUMAN RESOURCES
 PINECREST HOSPITAL
 105 SOUTH EISENHOWER DRIVE
 BECKLEY, WV
 25801 304-256-6614

DATE PRINTED	TERMS OF SALE	SHIP VIA	F.O.B.	FREIGHT TERMS
05/13/2009				

BID OPENING DATE: 05/26/2009 BID OPENING TIME 01:30PM

LINE	QUANTITY	UOP	CAT. NO.	ITEM NUMBER	UNIT PRICE	AMOUNT
0002	10	EA		936-73 UNINTERRUPTIBLE POWER SUPPLY	\$ 169.00	\$ 1690.00
0003	5	EA		936-73 16 CHANNEL POWER SUPPLY	\$ 136.50	\$ 682.50
0004	53	EA		936-73 SONY SPE-110 OR EQUAL, VANDAL PROOF DOME CAMERA	\$ 158.60	\$ 8,405.80
0005	10	EA		936-73 OUTDOOR CAMERA WITH 5-50 MM VARIFOCAL LENS	\$ 294.06	\$ 2,940.60
0006	10	EA		936-73 WEATHER PROOF HOUSING FOR OUTDOOR CAMERAS	Included above	\$0.00

SEE REVERSE SIDE FOR TERMS AND CONDITIONS

SIGNATURE	TELEPHONE	DATE
TITLE	FEIN	ADDRESS CHANGES TO BE NOTED ABOVE

WHEN RESPONDING TO RFQ, INSERT NAME AND ADDRESS IN SPACE ABOVE LABELED 'VENDOR'



State of West Virginia
 Department of Administration
 Purchasing Division
 2019 Washington Street East
 Post Office Box 50130
 Charleston, WV 25305-0130

Request for Quotation

RFQ NUMBER
PSH90126

PAGE
4

ADDRESS CORRESPONDENCE TO ATTENTION OF:
ROBERTA WAGNER
304-558-0067

VENDOR

RFQ COPY
 TYPE NAME/ADDRESS HERE

SHIP TO

HEALTH AND HUMAN RESOURCES
 PINECREST HOSPITAL
 105 SOUTH EISENHOWER DRIVE

BECKLEY, WV
 25801 304-256-6614

DATE PRINTED	TERMS OF SALE	SHIP VIA	F.O.B.	FREIGHT TERMS
05/13/2009				

BID OPENING DATE: 05/26/2009 BID OPENING TIME 01:30PM

LINE	QUANTITY	UOP	CAT. NO.	ITEM NUMBER	UNIT PRICE	AMOUNT
0007	1	JB		936-73	\$ 5,690.32	\$ 5,690.32
				MOUNTING BRACKETS, CABLE AND CABLE TERMINATIONS		
				Includes the requested Plenum Cable		
0008	1	JB		936-73	\$ 0.00	\$ 0.00
				REQUIRED SOFTWARE FOR SECURITY SYSTEM		
0009	1	JB		936-73	\$ 19,980.75	\$ 19,980.75
				LABOR COSTS		
0010	1	LS		936-73	\$ 3,260.03	\$ 3,260.03
				ALL OTHER COSTS (PLEASE SPECIFY)		
***** THIS IS THE END OF RFQ PSH90126 ***** TOTAL:					\$ 55,000.00	

SEE REVERSE SIDE FOR TERMS AND CONDITIONS

SIGNATURE <i>Alan E Long</i>	TELEPHONE 304-925-0338	DATE 06-09-09
TITLE Owner	FEIN 20-3881880	ADDRESS CHANGES TO BE NOTED ABOVE

WHEN RESPONDING TO RFQ, INSERT NAME AND ADDRESS IN SPACE ABOVE LABELED 'VENDOR'



State of West Virginia
 Department of Administration
 Purchasing Division
 2019 Washington Street East
 Post Office Box 50130
 Charleston, WV 25305-0130

Request for Quotation

RFQ NUMBER
 PSH90126

PAGE
 1

ADDRESS CORRESPONDENCE TO ATTENTION OF:
 ROBERTA WAGNER
 304-558-0067

VENDOR

*119161134 304-925-0338
 LONGS SECURITY CAMERA SYSTEMS
 102 38TH ST SE
 CHARLESTON WV 25304

SHIP TO

HEALTH AND HUMAN RESOURCES
 PINECREST HOSPITAL
 105 SOUTH EISENHOWER DRIVE
 BECKLEY, WV 25801 304-256-6614

DATE PRINTED	TERMS OF SALE	SHIP VIA	F.O.B.	FREIGHT TERMS
05/22/2009				

BID OPENING DATE: 06/09/2009 BID OPENING TIME 01:30PM

LINE	QUANTITY	UOP	CAT. NO.	ITEM NUMBER	UNIT PRICE	AMOUNT
ADDENDUM #02						
THIS ADDENDUM ISSUED TO EXTEND THE BID OPENING DATE FROM 5/26/2009 TO 6/9/2009; 1:30 PM.						
REVISED BID OPENING DATE: 6/9/2009; 1:30 PM						
0001	5	EA		936-73	\$ 2,470.00	\$ 12,350.00
DIGITAL VIDEO RECORDERS PER SPECIFICATIONS						
0002	10	EA		936-73	\$ 169.00	\$ 1,690.00
UNINTERRUPTIBLE POWER SUPPLY						

SEE REVERSE SIDE FOR TERMS AND CONDITIONS

SIGNATURE <i>Alan E. Jay</i>	TELEPHONE 304-925-0338	DATE 06-09-09
TITLE Owner	FEIN 20-3881880	ADDRESS CHANGES TO BE NOTED ABOVE

WHEN RESPONDING TO RFQ, INSERT NAME AND ADDRESS IN SPACE ABOVE LABELED 'VENDOR'



State of West Virginia
 Department of Administration
 Purchasing Division
 2019 Washington Street East
 Post Office Box 50130
 Charleston, WV 25305-0130

Request for Quotation

RFQ NUMBER
PSH90126

PAGE
1

ADDRESS CORRESPONDENCE TO ATTENTION OF:
ROBERTA WAGNER
304-558-0067

VENDOR

*119161134 304-925-0338
LONGS SECURITY CAMERA SYSTEMS
102 38TH ST SE
CHARLESTON WV 25304

SHIP TO

HEALTH AND HUMAN RESOURCES
PINECREST HOSPITAL
105 SOUTH EISENHOWER DRIVE
BECKLEY, WV
25801 **304-256-6614**

DATE PRINTED	TERMS OF SALE	SHIP VIA	F.O.B.	FREIGHT TERMS
05/28/2009				

BID OPENING DATE: **06/09/2009** BID OPENING TIME **01:30PM**

LINE	QUANTITY	UOP	CAT NO	ITEM NUMBER	UNIT PRICE	AMOUNT
<p>ADDENDUM NO. 3</p> <p>1. QUESTIONS AND ANSWERS ARE ATTACHED.</p> <p>2. ADDENDUM ACKNOWLEDGEMENT IS ATTACHED. THIS DOCUMENT SHOULD BE SIGNED AND RETURNED WITH YOUR BID. FAILURE TO SIGN AND RETURN MAY RESULT IN DISQUALIFICATION OF YOUR BID.</p> <p>EXHIBIT 10</p> <p>REQUISITION NO.: PSH90126</p> <p>ADDENDUM ACKNOWLEDGEMENT</p> <p>I HEREBY ACKNOWLEDGE RECEIPT OF THE FOLLOWING CHECKED ADDENDUM(S) AND HAVE MADE THE NECESSARY REVISIONS TO MY PROPOSAL, PLANS AND/OR SPECIFICATION, ETC.</p> <p>ADDENDUM NO.'S:</p> <p>NO. 1 ✓</p> <p>NO. 2 ✓</p> <p>NO. 3 ✓</p> <p>NO. 4 </p> <p>NO. 5 </p> <p>I UNDERSTAND THAT FAILURE TO CONFIRM THE RECEIPT OF THE ADDENDUM(S) MAY BE CAUSE FOR REJECTION OF BIDS.</p> <p>VENDOR MUST CLEARLY UNDERSTAND THAT ANY VERBAL REPRESENTATION MADE OR ASSUMED TO BE MADE DURING ANY</p>						

SEE REVERSE SIDE FOR TERMS AND CONDITIONS

SIGNATURE <i>Alan E. [Signature]</i>	TELEPHONE 304-925-0338	DATE 06-09-09
TITLE Owner	FEIN 20-3881880	ADDRESS CHANGES TO BE NOTED ABOVE

WHEN RESPONDING TO RFQ, INSERT NAME AND ADDRESS IN SPACE ABOVE LABELED 'VENDOR'



State of West Virginia
 Department of Administration
 Purchasing Division
 2019 Washington Street East
 Post Office Box 50130
 Charleston, WV 25305-0130

Request for Quotation

RFQ NUMBER
PSH90126

PAGE
2

ADDRESS CORRESPONDENCE TO ATTENTION OF:
ROBERTA WAGNER 304-558-0067

VENDOR

*119161134 304-925-0338
 LONGS SECURITY CAMERA SYSTEMS
 102 38TH ST SE
 CHARLESTON WV 25304

SHIP TO

HEALTH AND HUMAN RESOURCES
 PINECREST HOSPITAL
 105 SOUTH EISENHOWER DRIVE
 BECKLEY, WV
 25801 304-256-6614

DATE PRINTED	TERMS OF SALE	SHIP VIA	F.O.B.	FREIGHT TERMS
05/28/2009				

BID OPENING DATE: 06/09/2009 BID OPENING TIME 01:30PM

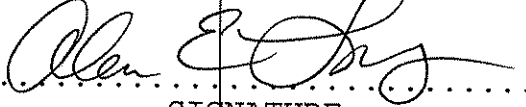
LINE	QUANTITY	UOP	CAT NO.	ITEM NUMBER	UNIT PRICE	AMOUNT
<p>ORAL DISCUSSION HELD BETWEEN VENDOR'S REPRESENTATIVES AND ANY STATE PERSONNEL IS NOT BINDING. ONLY THE INFORMATION ISSUED IN WRITING AND ADDED TO THE SPECIFICATIONS BY AN OFFICIAL ADDENDUM IS BINDING.</p> <p style="text-align: center;">  SIGNATURE Longs Security Camera Systems LLC COMPANY 06-09-09 DATE </p> <p>REV. 11/96</p> <p style="text-align: center;">END OF ADDENDUM NO. 3</p>						

SEE REVERSE SIDE FOR TERMS AND CONDITIONS			
SIGNATURE	TELEPHONE	DATE	
TITLE	FEIN	ADDRESS CHANGES TO BE NOTED ABOVE	

WHEN RESPONDING TO RFQ, INSERT NAME AND ADDRESS IN SPACE ABOVE LABELED 'VENDOR'

Agency Purchasing
REQ. P.O.# PSH90126
Bond # 19097

BID BOND

KNOW ALL MEN BY THESE PRESENTS, That we, the undersigned, Long's Security Camera System, LLC.
of 102 38th Street SE, Charleston, WV 25304 as Principal, and American Southern Insurance
Company of 7512 Slate Ridge Blvd. Reynoldsburg, OH 43068, a corporation organized and existing under the laws of the State of Kansas
with its principal office in the City of Atlanta, GA as Surety, are held and firmly bound unto the State
of West Virginia, as Obligee, in the penal sum of Two Thousand Seven Hundred Fifty and No/100 (\$ 2,750.00) for the payment of which,
well and truly to be made, we jointly and severally bind ourselves, our heirs, administrators, executors, successors and assigns.

The Condition of the above obligation is such that whereas the Principal has submitted to the Purchasing Section of the
Department of Administration a certain bid or proposal, attached hereto and made a part hereof, to enter into a contract in writing for
Pinecrest Hospital, Installation of Hospital Wide Camera System, Beckley, WV

NOW THEREFORE,

- (a) If said bid shall be rejected, or
- (b) If said bid shall be accepted and the Principal shall enter into a contract in accordance with the bid or proposal attached hereto and shall furnish any other bonds and insurance required by the bid or proposal, and shall in all other respects perform the agreement created by the acceptance of said bid, then this obligation shall be null and void, otherwise this obligation shall remain in full force and effect. It is expressly understood and agreed that the liability of the Surety for any and all claims hereunder shall, in no event, exceed the penal amount of this obligation as herein stated.

The Surety, for the value received, hereby stipulates and agrees that the obligations of said Surety and its bond shall be in no way impaired or affected by any extension of the time within which the Obligee may accept such bid, and said Surety does hereby waive notice of any such extension.

IN WITNESS WHEREOF, Principal and Surety have hereunto set their hands and seals, and such of them as are corporations have caused their corporate seals to be affixed hereunto and these presents to be signed by their proper officers, this
26th day of May, 2009.

Principal Corporate Seal

Long's Security Camera System, LLC.

(Name of Principal)
By Alan E. Gray
(Must be President or Vice President)
Owner/President
(Title)

Surety Corporate Seal

American Southern Insurance Company
(Name of Surety)

Andrew C. Heaner
Attorney-in-Fact
Andrew C. Heaner

IMPORTANT - Surety executing bonds must be licensed in West Virginia to transact surety insurance. Raised corporate seals must be affixed, a power of attorney must be attached.

AMERICAN SOUTHERN INSURANCE COMPANY

Home Office: 200 S.W. 30th Street
Topeka, Kansas 66611

Mailing Address: 3715 Northside Pkwy, NW
Bldg 400, Ste 800
Atlanta, Georgia 30327

GENERAL POWER OF ATTORNEY

Know all men by these Presents, that the American Southern Insurance Company had made, constituted and appointed, and by these presents does make, constitute and appoint Stefan E. Tauger of Parker, Colorado; Donald J. Kersey of Birmingham, Alabama; Arthur S. Johnson of Atlanta, Georgia; Jessica I. Boone of Locust Grove, Georgia; Mary F. Holland of Chamblee, Georgia; Donald H. Gibbs of Atlanta, Georgia; Andrew C. Heaner of Atlanta, Georgia; Richard L. Shanahan of Atlanta, Georgia; Katherine S. Grimsley of Tampa, Florida; Jeffery L. Booth of Parma, Ohio; James E. Feldner of West Lake, Ohio; Cheryl L. Torrao of Canton, Georgia; Lloyd Randall Deal of Kennesaw, Georgia; Garry W. Black of Murfreesboro, Tennessee; Martha G. Ross of Charlotte, North Carolina; or David R. Brett of Columbia, South Carolina; Diane M. Bailey of Phoenix, Arizona; Diane L. McLain of Fitchburg, Wisconsin, EACH as its true and lawful attorney for it and its name, place and stead to execute on behalf of the said company, as surety, bonds, undertakings and contracts of suretyship to be given to all obligees provided that no bond or undertaking or contract of suretyship executed under this authority shall exceed in amount of the sum of \$1,000,000 (one million dollars), including but not limited to consents of surety for the release of retained percentages and/or final estimates on construction contracts or similar authority requested by the Department of Transportation, State of Florida; and the execution of such undertakings, bonds, recognizances and other surety obligations, in pursuance of the presents, shall be as binding upon the Company as if they had been duly signed by the President and attested by the Secretary of the Company in their own proper persons.

This Power of Attorney is granted and is signed and sealed by facsimile under and by the authority of the following Resolution adopted pursuant to due authorization by the Executive Committee of the Board of Directors of the American Southern Insurance Company on the 26th day of May, 1998:

RESOLVED, that the Chairman, President or any Vice President of the Company be, and that each or any of them hereby is, authorized to execute Powers of Attorney qualifying the attorney named in the given Power of Attorney to execute in behalf of the American Southern Insurance Company bonds, undertakings and all contracts of suretyship; and that any Secretary or any Assistant Secretary be, and that each or any of them hereby is, authorized to attest the execution of any such Power of Attorney, and to attach thereto the seal of the Company.

FURTHER RESOLVED, that the signature of such officers and the seal of the Company may be affixed to any such Power of Attorney or to any certificate relating thereto by facsimile, and any such Power of Attorney or certificate bearing such facsimile signatures or facsimile seal shall be valid and binding upon the Company when so affixed and in the future, with respect to any bond undertaking or contract of suretyship to which it is attached.

In Witness Whereof, the American Southern Insurance Company has caused its official seal to be hereto affixed, and these presents to be signed by its President and attested by its Secretary this 24th day of March, 2008.

Attest: 
Gail A. Lee, Secretary

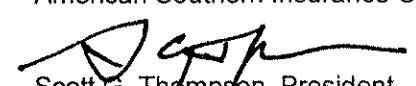
American Southern Insurance Company
By: 
Scott G. Thompson, President

STATE OF GEORGIA
SS:
COUNTY OF FULTON

On this 24th day of March, 2008, before me personally came Scott G. Thompson to me known, who being by me duly sworn, did depose and say that he resides in Atlanta, in the County of Fulton, State of Georgia, at 421 Hollydale Court; that he is the President of American Southern Insurance Company, the corporation described in and which executed the above instrument; that he knows the seal of the said corporation; that the seal affixed to the said instrument is such corporate seal; that it was so affixed and that he signed his name thereto pursuant to due authorization.

STATE OF GEORGIA
SS:
COUNTY OF FULTON

Melonie Coppola
Notary Public, State of Georgia
Qualified in Cobb County
Commission Expires May 17, 2010

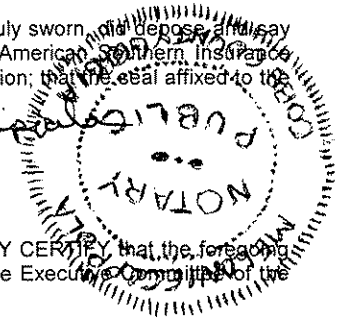

I, the undersigned, a Vice President of American Southern Insurance Company, a Kansas Corporation, DO HEREBY CERTIFY that the foregoing and attached Power of Attorney remains in full force and has not been revoked; and, furthermore, that the Resolution of the Executive Committee of the Board of Directors set forth in the Power of Attorney is now in force.

Signed and sealed at the City of Atlanta, Dated the 26th day of May, 2009.

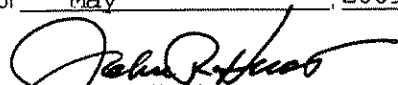
John R. Huot
Vice President

Power No. **19097**

American Southern Insurance Company
 NAIC Company Code 10235
 NAIC Group Code 587

Statutory Financial Statement

As of December 31, 2008

ASSETS		LIABILITIES	
Bonds	\$58,741,127	Reserve for Losses and Loss Expense	\$30,057,631
Stocks	23,177,949	Reserve for Unearned Premiums	16,236,876
Cash and Short-Term Investments	6,913,620	Reserve for Expenses, Taxes, Licenses and Fees	7,224,477
Agents Balances or Uncollected with Reinsured Companies	4,274,619	Payable to Parents, Subsidiaries and Affiliates	273,203
Other Assets	2,745,160	Other Liabilities	5,621,504
		Total Liabilities	59,413,691
		POLICYHOLDERS' SURPLUS	
		Capital Stock	3,000,000
		Surplus	33,438,784
		Total Policyholders' Surplus	36,438,784
Total Assets	\$95,852,475	Total Liabilities and Policyholders' Surplus	\$95,852,475

Bonds and stocks are valued in accordance with the basis adopted by the National Association of Insurance Commissioners (NAIC).

CERTIFICATE

The officers of this reporting entity being duly sworn, each depose and say that they are the described officers of said reporting entity, and that on the reporting period stated above, all of the herein described assets were the absolute property of the said reporting entity, free and clear from any liens or claims thereon, except as herein stated, and that this statement, together with related exhibits, schedules and explanations therein contained, annexed or referred to, is a full and true statement of all the assets and liabilities and of the condition and affairs of the said reporting entity as of the reporting period stated above, and of its income and deductions therefrom for the period ended, and have been completed in accordance with the NAIC Annual Statement Instructions and Accounting Practices and Procedures manual except to the extent that: (1) state law may differ; or, (2) that state rules or regulations require differences in reporting not related to accounting practices and procedures, according to the best of their information, knowledge and belief, respectively.

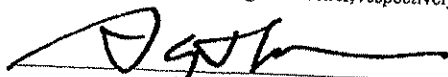

 President



 Chief Financial Officer

State of Georgia
 County of Fulton

On the 13th day of March 2009, before me came the above named officers of the American Southern Insurance Company to me personally known to be the individuals and officers described herein, and acknowledge that they executed the foregoing instrument and affixed the seal of said company thereto by authority of their office.

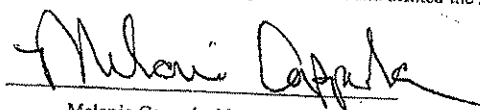

 Melonie Coppola, Notary Public
 My Commission Expires, May 17, 2010

CONTRACTOR LICENSE

Authorized by the

West Virginia Contractor Licensing Board

Number: WV040102

Classification:

LOW VOLTAGE SYSTEMS

LONGS SECURITY CAMERA SYSTEMS LLC
DBA LONGS SECURITY CAMERA SYSTEMS LLC
102 38TH STREET SE
CHARLESTON, WV 25304

Date Issued

Expiration Date

JANUARY 26, 2009

JANUARY 26, 2010

Authorized Company Signature

Michael A. Carl
Chair, West Virginia Contractor
Licensing Board



**WEST VIRGINIA
CONTRACTOR
LICENSING
BOARD**

This license, or a copy thereof, must be posted in a conspicuous place at every construction site where work is being performed. This license number must appear in all advertisements, on all bid submissions and on all fully executed and binding contracts. This license cannot be assigned or transferred by licensee. Issued under provisions of West Virginia Code, Chapter 21, Article 11.

ACORD CERTIFICATE OF LIABILITY INSURANCE

DATE (MM/DD/YY)

5/20/09

PRODUCER

Wells Fargo Ins. Services
of West Virginia, Inc.
P.O. Box 1551
Charleston WV 25326-1551
(304) 346-0611

THIS CERTIFICATE IS ISSUED AS A MATTER OF INFORMATION ONLY AND CONFERS NO RIGHTS UPON THE CERTIFICATE HOLDER. THIS CERTIFICATE DOES NOT AMEND, EXTEND OR ALTER THE COVERAGE AFFORDED BY THE POLICIES BELOW.

COMPANIES AFFORDING COVERAGE

- COMPANY
A Landmark American Insurance Co
- COMPANY
B
- COMPANY
C
- COMPANY
D

INSURED

Long's Security Camera Systems
102 38th St SE
Charleston, WV 25304

COVERAGES

THIS IS TO CERTIFY THAT THE POLICIES OF INSURANCE LISTED BELOW HAVE BEEN ISSUED TO THE INSURED NAMED ABOVE FOR THE POLICY PERIOD INDICATED, NOT WITHSTANDING ANY REQUIREMENT, TERM OR CONDITION OF ANY CONTRACT OR OTHER DOCUMENT WITH RESPECT TO WHICH THIS CERTIFICATE MAY BE ISSUED OR MAY PERTAIN, THE INSURANCE AFFORDED BY THE POLICIES DESCRIBED HEREIN IS SUBJECT TO ALL THE TERMS, EXCLUSIONS AND CONDITIONS OF SUCH POLICIES. LIMITS SHOWN MAY HAVE BEEN REDUCED BY PAID CLAIMS.

CO LTR	TYPE OF INSURANCE	POLICY NUMBER	POLICY EFFECTIVE DATE (MM/DD/YY)	POLICY EXPIRATION DATE (MM/DD/YY)	LIMITS												
A	GENERAL LIABILITY <input checked="" type="checkbox"/> COMMERCIAL GENERAL LIABILITY <input type="checkbox"/> CLAIMS MADE <input type="checkbox"/> OCCUR <input type="checkbox"/> OWNER'S & CONTRACTOR'S PROT	LBA032759	3/11/09	3/11/10	<table border="1"> <tr><td>GENERAL AGGREGATE</td><td>\$ 2,000,000</td></tr> <tr><td>PRODUCTS-COMP/OP AGG</td><td>\$ 2,000,000</td></tr> <tr><td>PERSONAL & ADV INJURY</td><td>\$ 1,000,000</td></tr> <tr><td>EACH OCCURRENCE</td><td>\$ 1,000,000</td></tr> <tr><td>FIRE DAMAGE (Any one fire)</td><td>\$ 100,000</td></tr> <tr><td>MED EXP (Any one person)</td><td>\$ 5,000</td></tr> </table>	GENERAL AGGREGATE	\$ 2,000,000	PRODUCTS-COMP/OP AGG	\$ 2,000,000	PERSONAL & ADV INJURY	\$ 1,000,000	EACH OCCURRENCE	\$ 1,000,000	FIRE DAMAGE (Any one fire)	\$ 100,000	MED EXP (Any one person)	\$ 5,000
GENERAL AGGREGATE	\$ 2,000,000																
PRODUCTS-COMP/OP AGG	\$ 2,000,000																
PERSONAL & ADV INJURY	\$ 1,000,000																
EACH OCCURRENCE	\$ 1,000,000																
FIRE DAMAGE (Any one fire)	\$ 100,000																
MED EXP (Any one person)	\$ 5,000																
	AUTOMOBILE LIABILITY <input type="checkbox"/> ANY AUTO <input type="checkbox"/> ALL OWNED AUTOS <input type="checkbox"/> SCHEDULED AUTOS <input type="checkbox"/> HIRED AUTOS <input type="checkbox"/> NON-OWNED AUTOS				<table border="1"> <tr><td>COMBINED SINGLE LIMIT</td><td>\$</td></tr> <tr><td>BODILY INJURY (Per person)</td><td>\$</td></tr> <tr><td>BODILY INJURY (Per accident)</td><td>\$</td></tr> <tr><td>PROPERTY DAMAGE</td><td>\$</td></tr> </table>	COMBINED SINGLE LIMIT	\$	BODILY INJURY (Per person)	\$	BODILY INJURY (Per accident)	\$	PROPERTY DAMAGE	\$				
COMBINED SINGLE LIMIT	\$																
BODILY INJURY (Per person)	\$																
BODILY INJURY (Per accident)	\$																
PROPERTY DAMAGE	\$																
	GARAGE LIABILITY <input type="checkbox"/> ANY AUTO				<table border="1"> <tr><td>AUTO ONLY - EA ACCIDENT</td><td>\$</td></tr> <tr><td>OTHER THAN AUTO ONLY:</td><td></td></tr> <tr><td> EACH ACCIDENT</td><td>\$</td></tr> <tr><td> AGGREGATE</td><td>\$</td></tr> </table>	AUTO ONLY - EA ACCIDENT	\$	OTHER THAN AUTO ONLY:		EACH ACCIDENT	\$	AGGREGATE	\$				
AUTO ONLY - EA ACCIDENT	\$																
OTHER THAN AUTO ONLY:																	
EACH ACCIDENT	\$																
AGGREGATE	\$																
	EXCESS LIABILITY <input type="checkbox"/> UMBRELLA FORM <input type="checkbox"/> OTHER THAN UMBRELLA FORM				<table border="1"> <tr><td>EACH OCCURRENCE</td><td>\$</td></tr> <tr><td>AGGREGATE</td><td>\$</td></tr> <tr><td></td><td>\$</td></tr> </table>	EACH OCCURRENCE	\$	AGGREGATE	\$		\$						
EACH OCCURRENCE	\$																
AGGREGATE	\$																
	\$																
	WORKERS COMPENSATION AND EMPLOYERS' LIABILITY THE PROPRIETOR/PARTNERS/EXECUTIVE OFFICERS ARE: <input type="checkbox"/> INCL <input type="checkbox"/> EXCL				<table border="1"> <tr><td>WC STATUTORY LIMITS</td><td>OTHER</td></tr> <tr><td>EL EACH ACCIDENT</td><td>\$</td></tr> <tr><td>EL DISEASE-POLICY LIMIT</td><td>\$</td></tr> <tr><td>EL DISEASE-EA EMPLOYEE</td><td>\$</td></tr> </table>	WC STATUTORY LIMITS	OTHER	EL EACH ACCIDENT	\$	EL DISEASE-POLICY LIMIT	\$	EL DISEASE-EA EMPLOYEE	\$				
WC STATUTORY LIMITS	OTHER																
EL EACH ACCIDENT	\$																
EL DISEASE-POLICY LIMIT	\$																
EL DISEASE-EA EMPLOYEE	\$																
	OTHER																

DESCRIPTION OF OPERATIONS/LOCATIONS/VEHICLES/SPECIAL ITEMS

COPY

CERTIFICATE HOLDER

Pinecrest Hospital
Health & Human Resources
105 S Eisenhower Dr
Beckley, WV 25801

CANCELLATION

SHOULD ANY OF THE ABOVE DESCRIBED POLICIES BE CANCELLED BEFORE THE EXPIRATION DATE THEREOF, THE ISSUING COMPANY WILL ENDEAVOR TO MAIL 10 DAYS WRITTEN NOTICE TO THE CERTIFICATE HOLDER NAMED TO THE LEFT, BUT FAILURE TO MAIL SUCH NOTICE SHALL IMPOSE NO OBLIGATION OR LIABILITY OF ANY KIND UPON THE COMPANY, ITS AGENTS OR REPRESENTATIVES.

AUTHORIZED REPRESENTATIVE

Tammy Bowles

Tammy Bowles

IMPORTANT

If the certificate holder is an ADDITIONAL INSURED, the policy(ies) must be endorsed. A statement on this certificate does not confer rights to the certificate holder in lieu of such endorsement(s).

If SUBROGATION IS WAIVED, subject to the terms and conditions of the policy, certain policies may require an endorsement. A statement on this certificate does not confer rights to the certificate holder in lieu of such endorsement(s).

DISCLAIMER

The Certificate of Insurance on the reverse side of this form does not constitute a contract between the issuing insurer(s), authorized representative or producer, and the certificate holder, nor does it affirmatively or negatively amend, extend or alter the coverage afforded by the policies listed thereon.

State of West Virginia VENDOR PREFERENCE CERTIFICATE

Certification and application* is hereby made for Preference in accordance with **West Virginia Code**, §5A-3-37. (Does not apply to construction contracts). **West Virginia Code**, §5A-3-37, provides an opportunity for qualifying vendors to request (at the time of bid) preference for their residency status. Such preference is an evaluation method only and will be applied only to the cost bid in accordance with the **West Virginia Code**. This certificate for application is to be used to request such preference. The Purchasing Division will make the determination of the Resident Vendor Preference, if applicable.

- 1. **Application is made for 2.5% resident vendor preference for the reason checked:**
 Bidder is an individual resident vendor and has resided continuously in West Virginia for four (4) years immediately preceding the date of this certification; **or**,
 Bidder is a partnership, association or corporation resident vendor and has maintained its headquarters or principal place of business continuously in West Virginia for four (4) years immediately preceding the date of this certification; **or** 80% of the ownership interest of Bidder is held by another individual, partnership, association or corporation resident vendor who has maintained its headquarters or principal place of business continuously in West Virginia for four (4) years immediately preceding the date of this certification; **or**,
 Bidder is a nonresident vendor which has an affiliate or subsidiary which employs a minimum of one hundred state residents and which has maintained its headquarters or principal place of business within West Virginia continuously for the four (4) years immediately preceding the date of this certification; **or**,
- 2. **Application is made for 2.5% resident vendor preference for the reason checked:**
 Bidder is a resident vendor who certifies that, during the life of the contract, on average at least 75% of the employees working on the project being bid are residents of West Virginia who have resided in the state continuously for the two years immediately preceding submission of this bid; **or**,
- 3. **Application is made for 2.5% resident vendor preference for the reason checked:**
 Bidder is a nonresident vendor employing a minimum of one hundred state residents or is a nonresident vendor with an affiliate or subsidiary which maintains its headquarters or principal place of business within West Virginia employing a minimum of one hundred state residents who certifies that, during the life of the contract, on average at least 75% of the employees or Bidder's affiliate's or subsidiary's employees are residents of West Virginia who have resided in the state continuously for the two years immediately preceding submission of this bid; **or**,
- 4. **Application is made for 5% resident vendor preference for the reason checked:**
 Bidder meets either the requirement of both subdivisions (1) and (2) or subdivision (1) and (3) as stated above; **or**,
- 5. **Application is made for 3.5% resident vendor preference who is a veteran for the reason checked:**
 Bidder is an individual resident vendor who is a veteran of the United States armed forces, the reserves or the National Guard and has resided in West Virginia continuously for the four years immediately preceding the date on which the bid is submitted; **or**,
- 6. **Application is made for 3.5% resident vendor preference who is a veteran for the reason checked:**
 Bidder is a resident vendor who is a veteran of the United States armed forces, the reserves or the National Guard, if, for purposes of producing or distributing the commodities or completing the project which is the subject of the vendor's bid and continuously over the entire term of the project, on average at least seventy-five percent of the vendor's employees are residents of West Virginia who have resided in the state continuously for the two immediately preceding years.

Bidder understands if the Secretary of Revenue determines that a Bidder receiving preference has failed to continue to meet the requirements for such preference, the Secretary may order the Director of Purchasing to: (a) reject the bid; or (b) assess a penalty against such Bidder in an amount not to exceed 5% of the bid amount and that such penalty will be paid to the contracting agency or deducted from any unpaid balance on the contract or purchase order.

By submission of this certificate, Bidder agrees to disclose any reasonably requested information to the Purchasing Division and authorizes the Department of Revenue to disclose to the Director of Purchasing appropriate information verifying that Bidder has paid the required business taxes, provided that such information does not contain the amounts of taxes paid nor any other information deemed by the Tax Commissioner to be confidential.

Under penalty of law for false swearing (West Virginia Code, §61-5-3), Bidder hereby certifies that this certificate is true and accurate in all respects; and that if a contract is issued to Bidder and if anything contained within this certificate changes during the term of the contract, Bidder will notify the Purchasing Division in writing immediately.

Bidder: Long's Security Camera Systems LLC Signed: Allen E. Long
Date: 06-09-09 Title: Owner

*Check any combination of preference consideration(s) indicated above, which you are entitled to receive.

AGREEMENT ADDENDUM

In the event of conflict between this addendum and the agreement, this addendum shall control:

1. **DISPUTES** - Any references in the agreement to arbitration or to the jurisdiction of any court are hereby deleted. Disputes arising out of the agreement shall be presented to the West Virginia Court of Claims.
2. **HOLD HARMLESS** - Any clause requiring the Agency to indemnify or hold harmless any party is hereby deleted in its entirety.
3. **GOVERNING LAW** - The agreement shall be governed by the laws of the State of West Virginia. This provision replaces any references to any other State's governing law.
4. **TAXES** - Provisions in the agreement requiring the Agency to pay taxes are deleted. As a State entity, the Agency is exempt from Federal, State, and local taxes and will not pay taxes for any Vendor including individuals, nor will the Agency file any tax returns or reports on behalf of Vendor or any other party.
5. **PAYMENT** - Any references to prepayment are deleted. Payment will be in arrears.
6. **INTEREST** - Should the agreement include a provision for interest on late payments, the Agency agrees to pay the maximum legal rate under West Virginia law. All other references to interest or late charges are deleted.
7. **RECOURPMENT** - Any language in the agreement waiving the Agency's right to set-off, counterclaim, recoupment, or other defense is hereby deleted.
8. **FISCAL YEAR FUNDING** - Service performed under the agreement may be continued in succeeding fiscal years for the term of the agreement, contingent upon funds being appropriated by the Legislature or otherwise being available for this service. In the event funds are not appropriated or otherwise available for this service, the agreement shall terminate without penalty on June 30. After that date, the agreement becomes of no effect and is null and void. However, the Agency agrees to use its best efforts to have the amounts contemplated under the agreement included in its budget. Non-appropriation or non-funding shall not be considered an event of default.
9. **STATUTE OF LIMITATION** - Any clauses limiting the time in which the Agency may bring suit against the Vendor, lessor, individual, or any other party are deleted.
10. **SIMILAR SERVICES** - Any provisions limiting the Agency's right to obtain similar services or equipment in the event of default or non-funding during the term of the agreement are hereby deleted.
11. **ATTORNEY FEES** - The Agency recognizes an obligation to pay attorney's fees or costs only when assessed by a court of competent jurisdiction. Any other provision is invalid and considered null and void.
12. **ASSIGNMENT** - Notwithstanding any clause to the contrary, the Agency reserves the right to assign the agreement to another State of West Virginia agency, board or commission upon thirty (30) days written notice to the Vendor and Vendor shall obtain the written consent of Agency prior to assigning the agreement.
13. **LIMITATION OF LIABILITY** - The Agency, as a State entity, cannot agree to assume the potential liability of a Vendor. Accordingly, any provision limiting the Vendor's liability for direct damages to a certain dollar amount or to the amount of the agreement is hereby deleted. Limitations on special, incidental or consequential damages are acceptable. In addition, any limitation is null and void to the extent that it precludes any action for injury to persons or for damages to personal property.
14. **RIGHT TO TERMINATE** - Agency shall have the right to terminate the agreement upon thirty (30) days written notice to Vendor. Agency agrees to pay Vendor for services rendered or goods received prior to the effective date of termination.
15. **TERMINATION CHARGES** - Any provision requiring the Agency to pay a fixed amount or liquidated damages upon termination of the agreement is hereby deleted. The Agency may only agree to reimburse a Vendor for actual costs incurred or losses sustained during the current fiscal year due to wrongful termination by the Agency prior to the end of any current agreement term.
16. **RENEWAL** - Any reference to automatic renewal is hereby deleted. The agreement may be renewed only upon mutual written agreement of the parties.
17. **INSURANCE** - Any provision requiring the Agency to insure equipment or property of any kind and name the Vendor as beneficiary or as an additional insured is hereby deleted.
18. **RIGHT TO NOTICE** - Any provision for repossession of equipment without notice is hereby deleted. However, the Agency does recognize a right of repossession with notice.
19. **ACCELERATION** - Any reference to acceleration of payments in the event of default or non-funding is hereby deleted.
20. **CONFIDENTIALITY**: -Any provision regarding confidentiality of the terms and conditions of the agreement is hereby deleted. State contracts are public records under the West Virginia Freedom of Information Act.
21. **AMENDMENTS** - All amendments, modifications, alterations or changes to the agreement shall be in writing and signed by both parties. No amendment, modification, alteration or change may be made to this addendum without the express written approval of the Purchasing Division and the Attorney General.

ACCEPTED BY:
STATE OF WEST VIRGINIA _____

Spending Unit: _____

Signed: _____

Title: _____

Date: _____

VENDOR

Company Name: Longs Security Camera Systems LLC

Signed: Alan E Long

Title: Owner

Date: 06-09-09

LSCS DSS-6480ex

16 Channel Digital Recorders

Video Features

- **16 composite video inputs (BNC Connectors) and/or 16 IP camera (selected IP cameras), Max. of 32 video feed per system (for 2 cards)**
- **16 audio input channels (32 channels with 2 cards)**
- **Video Format: NTSC**
- **Support 320x240, 640x480, or 720x480 (enhanced) pixels (NTSC & PAL) 16-bit true color or 1920x1200 (Selected 2.3MPixel IP Cameras)**
- **RCA composite video out to a regular terminal or TV monitor**
- **Supports static as well as dynamic de-interlacing for smoother graphics**
- **Built in noise reduction algorithm**

Display

- **Compact mode and Advanced mode**
- **Adjustable frame rate and resolution on each camera**
- **Auto Scan with full screen display under 1, 4, 8, 9, 16-camera display modes**
- **Digital zoom into specific area**
- **Pan/Tilt/Zoom (PTZ) cameras: PTZ script is available for adding new protocols**
- **Auto Gain Control (AGC) balance image quality**
- **Software based night view function enhances low light condition**

Recording

- **Video compression: Advanced MPEG4 / H.264**
- **Supports 320x240, 640x480, and 720x480 up to 1920x1200 with selected Megapixel IP Cameras Recording up to 1920x1200 (Selected 2.3MPixel IP Cameras)**
- **Fully de-interlace in 640x480 and 720x480 mode**
- **Recording modes: Alarm triggered/ sensor triggered/ motion detection/ continuous/ smart/ scheduled/ voice detection**
- **Motion Detection / Continuous / Smart / Voice / Schedule recording**
- **Programmable multiple masking zones**
- **Intelligent shield protects privacy**
- **Auto recycling when storage disk is full**
- **Intelligent pre-motion and post motion recording**
- **Max 16 audio channels recording (32 channels with 2 cards)**
- **Supports video encryption in Advanced MPEG4**

Search & Playback & Backup

- **Real time playback: immediate access to playback**
- **Powerful search: by date, time, camera, area, event, vision, POS text or log file**
- **Complete playback control: playback, backward playback, fast forward/backward playback, forward/backward frame-by-frame playback**
- **Digital zoom in for specific area**
- **Export single frame to BMP file and print out**
- **Output "AVI" file for video clip**
- **Visual search by day, hour, minute, second**
- **Bookmark search: By time, description. Protect recorded file from being recycled and show file status**

Remote Web Access

- **Simultaneous multiple remote LIVE surveillance via standard web browsers (Internet Explorer 6)**
- **Backup remotely**
- **Central Management Server Controls multiple DVRs**
- **Multiple servers connectivity**
- **Remote monitoring / recording / playback / retrieve through LAN or Internet**
- **Remote PTZ control**
- **2-way audio**
- **Two-way audio communication**
- **PDA handy view (Windows CE 3.0 / Pocket PC 2002)**
- **DDNS function supports dynamic IP**
- **1,4,9 and 16 screen divisions**
- **Remote E-map**
- **Choose from dial-up, Internet or Lan speed**
- **Dispatch server allows you to broadcast video stream to the public**
- **DDNS function supports dynamic IP**

Schedule

- **Record, Network enable, backup, reboot, and disabling alarms**
- **One time or weekly repeat schedule**
- **Scheduling can be done down to every quarter of an hour**

E-map

- **Record, Network enable, backup, reboot, and disabling alarms**
- **One time or weekly repeat schedule**
- **Scheduling can be done down to every quarter of an hour**

Alarm Notifications (on motion detected, video loss and/or sensor triggered)

- E-mail notifications
- FTP notifications
- Voice modem call out notification
- Turn relay on (light switch, alarm, etc)
- Plays warning sound (can be re-recorded)
- Start recording on multiple cameras (capture video from different angle)
- Send TV-out signals
- Launch E-Map
- Enlarge camera view
- Send SMS/MMS (Requires SMS Modem)
- Sends Event to Central Monitoring Server
- Alert messages helps security follow proper standard operational procedures

User Access

- Setup up to 32 users with their own individual passwords for remote access
- Each user can be preconfigured to perform only certain actions (eg. access specific cameras remotely)

Achievable Configuration

Product	DSS-6480 EX (PCI-E)
Video Input	16 Channels (single card)/ 32 Channels (Stackable)
Audio Input	16 channels
Display Rate(NTSC / PAL)	480/400 fps
Recording Rate (NTSC / PAL) (CIF)	480/400 fps
Recording Rate(NTSC / PAL) (VGA)	480/400 fps **
Recording Rate(NTSC / PAL) (D1)	160 / 128 fps
TV-OUT	Configurable multiplexed screen
Interface	High speed PCI-E
Size	165 x 105 mm

* Specifications are subject to change without prior notice

** Attainable with the use of Intel Core? Duo processor 2.4GHz or above



ALTV2416, ALTV2416CB AC CCTV Power Supply

Rev. DSALTV2416 - A24F

Overview

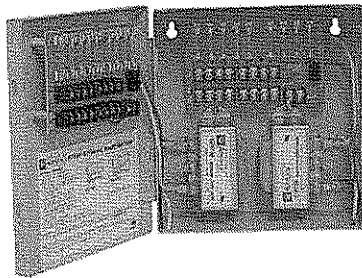

- These Altronix AC Wall Mount CCTV Power Supplies provide 24VAC or 28VAC distributed via sixteen (16) fuse or PTC protected outputs for powering CCTV Cameras, heaters and other video accessories.

ALTV2416

- Sixteen (16) fuse protected outputs.
- Outputs are rated @ 3.5 amp.

ALTV2416CB

- Sixteen (16) PTC protected outputs.
- Outputs are rated @ 2.5 amp.

Specifications

- Input 115VAC, 50/60Hz, 1.9 amp.
- 24VAC @ 8 amp (200VA) or 28VAC @ 7 amp (200VA) supply current.
- Main fuse rated @ 10 amp/250V.
- Power ON/OFF switch.
- Surge suppression.
- AC power LEDs.
- Spare fuse(s) provided (all models w/primary and/or secondary fuses).
- Unit maintains camera synchronization.
- Ease of installation saves time and eliminates costly labor.
- Product weight:
 - ALTV2416: 9.5 lbs.
 - ALTV2416CB: 9.5 lbs.
- Shipping weight:
 - ALTV2416: 10.1 lbs.
 - ALTV2416CB: 10.1 lbs.

Agency Approvals

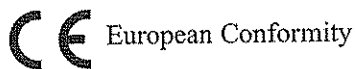

EasyView

Most installer friendly cameras.



DAY/NIGHT • IR LED VANDALPROOF DOME

CV-SD21N/P-L



Flush Mount w/ IR LEDs Module

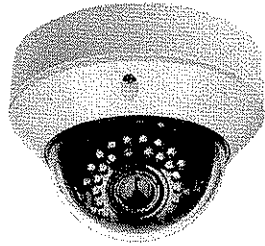

Flush Housing with Surface Mount

Key Features

- 1/3" CCD Sensor
- 550 TV Lines
- Day/Night function with ICR
- 2.8-10mm, DC Auto Iris
- 0.1 Lux(Color), 0.01 Lux(B/W), 0.002 Lux(DSS On)
- 36 IR LEDs
- Separate Camera Control Board
 - OSD Menu
 - Service Monitor Output
- 12VDC/24VAC Dual Voltage

Construction

- 4" Polycarbonate Bubble
- 3-Axis Gimbal
- Flush Mount Housing w/ Surface Mount Plate in a single package
- Impact Resistant Dome w/ Aluminum Housing
- Weatherproof - IP66
- Aluminum Mounting Accessories(Optional)
- Fan & Heater(Optional)
- Compact Size

Dome Inside View

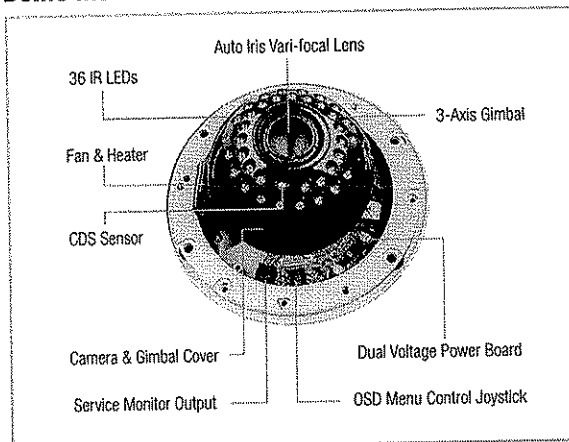

Technical Specifications

Item	CV-SD21N/P-L
Video Format	NTSC / PAL
Image Sensor	1/3" CCD
Sync System	Internal / Line Lock(Optional)
Effective Pixels	768(H) x 494(V)(N) / 752(H) x 582(V)(P)
Scanning System	525 Lines. 2:1 Interlaced(N), 625 Lines. 2:1 Interlaced(P)
Electronic Shutter	1/60 ~ 1/120,000 sec.(N), 1/50 ~ 1/120,000 sec.(P)
Main Video Output	1.0 Vp-p Composite, 75 ohm
Service Monitor Output	1.0 Vp-p Composite, 75 ohm
Horizontal Resolution	550 TV Lines
Min. Illumination	0.1 Lux(Color), 0.01 Lux(B/W) 0.002 Lux(DSS On)
S/N Ratio	More than 50dB(AGC Off)
Lens (DC Auto Iris)	Vari-focal: 2.8-10mm
Angle of View	132.1°(W) ~ 36°(T)
Day/Night Function	ICR
36 IR LEDs	LED Distance: up to 100ft.
LED Illumination Angle	60°
Camera Control & Setup	OSD Menu
Operating Temperature	-5°C ~ +45°C(Normal), -40°C ~ +45°C(w/ Fan & Heater)
Operating Humidity	Within 90% RH
Weatherproof	IP66(Only applies to Vandalproof Housing)
Power Consumption	500mA (Camera) 1 Amp (w/ LED On)
	Fan & Heater - 20VA(24VAC Only)
Input Voltage	12VDC/24VAC Dual Voltage

* Must use specified and regulated 12VDC/24VAC power supply.

Accessories

CV-FH	Fan & Heater
CA-SMC30	Service Monitor Cable
CV-WM	Indoor Wall Mount
CA-OM	Outdoor Wall Mount
CA-PM	Pedestal Mount
CA-JB	Junction Box

Dimensions (UNIT: mm)

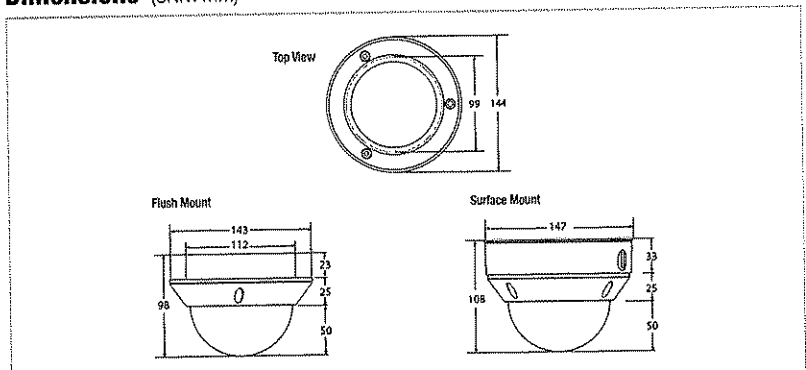

NUVICO

Corporate Headquarters | T 866.523.1700 • 201.541.1605 • sales@nuvico.com
International Operations | export@nuvico.com

Customer Service | cs@nuvico.com
Technical Support | techsupport@nuvico.com

Bullet Camera

Day/Night, 550 TV Lines, 60 IR LED Weatherproof Bullet Camera

CB-HD65N-L

NTSC

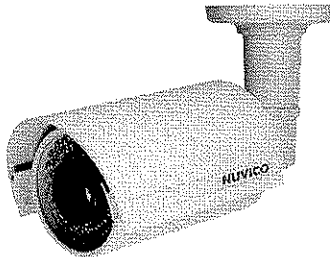

KEY FEATURES

- 1/3" CCD Sensor
- 550 TV Lines (Color), 600 TV Lines (B/W)
- 6--50mm, DC Auto Iris
- Day/Night Functionality with ICR
- 0.3 Lux (Color), 0.00 Lux (B/W, IR LED On)
- 60 IR LEDs
- Adjustable IR LED Intensity
- Service Monitor Output
- 12VDC/24VAC Dual Voltage

CONSTRUCTION

- 3-Axis Aluminum Bracket (Wire feed-through)
- Weatherproof Aluminum Housing

TECHNICAL SPECIFICATIONS

Technical Specifications	CB-HD65N-L
Video Format	NTSC/PAL
Image Sensor	1/3" CCD
Horizontal Resolution	550 TV Lines (Color), 600 TV Lines (B/W)
Day/Night Functionality	Yes w/ ICR
Lens Type (DC Auto Iris)	Vari-focal 6mm-50mm
Angle of View	54°(W) ~ 7.6°(T)
IR LED	60
IR LED Distance	Up to 200ft
LED Illumination Angle	20°
Sync System	Internal
Effective Pixels (HxV)	768(H) x 494(V)
Scanning System	525 Lines, 2:1 Interlaced
Electronic Shutter	1/60 sec.
Main Video Output	1.0 Vp-p Composite, 75 ohm
Service Monitor Output	1.0 Vp-p Composite, 75 ohm
Minimum Illumination	0.3 Lux (Color), 0.00 Lux (B/W, IR LED On)
S/N Ratio	More than 50dB (AGC Off)
Camera Control & Setup	Dip Switch Menu
General Information	CB-HD65N-L
Operating Temperature	23°F ~ 113°F
Operating Humidity	Within 90% RH
Power Consumption	1 Amp (LED On), 500 mA (Camera Only)
Input Voltage	12VDC/24VAC Dual Voltage

*specifications are subject to change without any prior notice.

PART NAMES AND LOCATIONS

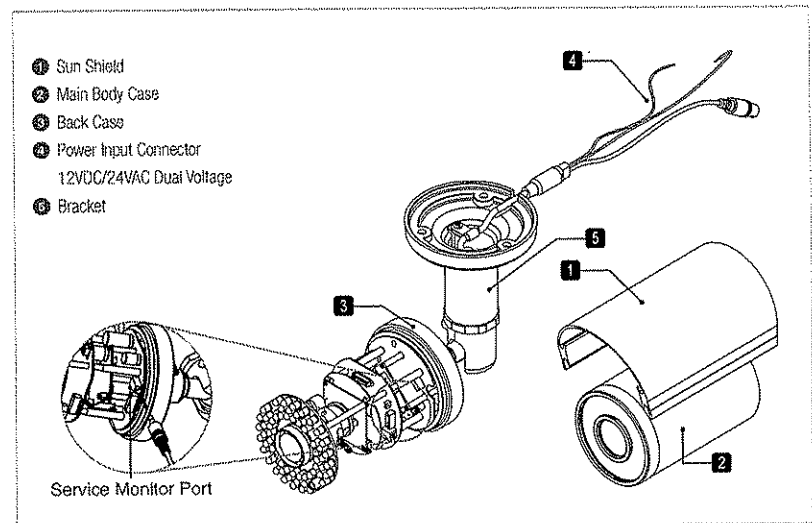

DIMENSIONS

Unit: mm

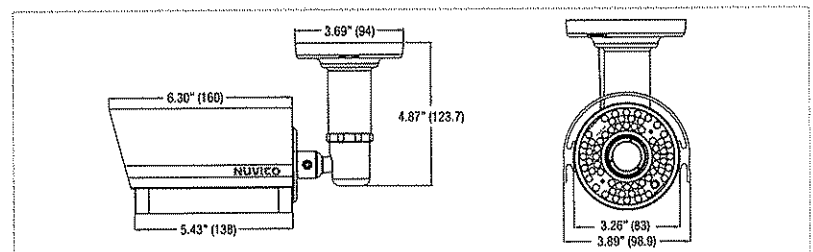

NUVICO

Corporate Headquarters | sales@nuvico.com • T. 866.623.1700 • 201.541.1605
International Operations | export@nuvico.com

Customer Service | cs@nuvico.com
Technical Support | techsupport@nuvico.com



CB-SD21N/P-L

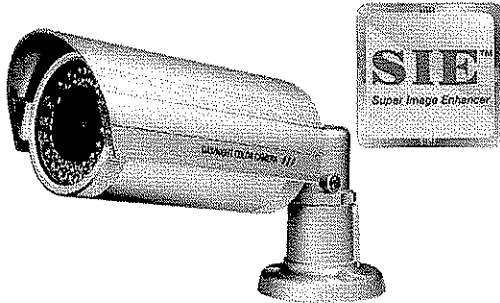

Key Features

- 1/3" CCD Sensor
- 550 TV Lines
- Day/Night function with ICR
- 2.8~10mm, DC Auto Iris
- 0.1 Lux(Color), 0.01 Lux(B/W), 0.002 Lux(DSS On)
- 36 IR LEDs
- Separate Camera Control Board
 - OSD Menu
 - Service Monitor Output
- 12VDC/24VAC Dual Voltage

Construction

- Aluminum Housing(Weatherproof)
- Aluminum Bracket(Wire feed-through)

Technical Specifications NTSC = (N), PAL = (P)

Item	CB-SD21N/P-L
Video Format	NTSC / PAL
Image Sensor	1/3" CCD
Sync System	Internal
Effective Pixels	768(H) x 494(V)(N) / 752(H) x 582(V)(P)
Scanning System	525 Lines. 2:1 Interlaced(N), 625 Lines. 2:1 Interlaced(P)
Electronic Shutter	1/60 ~ 1/120,000 sec.(N), 1/50 ~ 1/120,000 sec.(P)
Main Video Output	1.0 Vp-p Composite, 75 ohm
Service Monitor Output	1.0 Vp-p Composite, 75 ohm
Horizontal Resolution	550 TV Lines
Min. Illumination	0.1 Lux(Color), 0.01 Lux(B/W), 0.002 Lux(DSS On)
S/N Ratio	More than 50dB(AGC Off)
Lens (DC Auto Iris)	Vari-focal: 2.8-10mm
Angle of View	132.1°(W) ~ 36°(T)
Day/Night Function	ICR
36 IR LEDs	LED Distance: up to 100ft.
LED Illumination Angle	60°
Camera Control & Setup	OSD Menu
Operating Temperature	-5°C ~ +45°C
Operating Humidity	Within 90% RH
Weatherproof	IP66
Power Consumption	500mA (Camera) 1 Amp (w/ LED On)
Input Voltage	12VDC/24VAC Dual Voltage

* Must use specified and regulated 12VDC/24VAC power supply.

Dimensions (UNIT: mm)

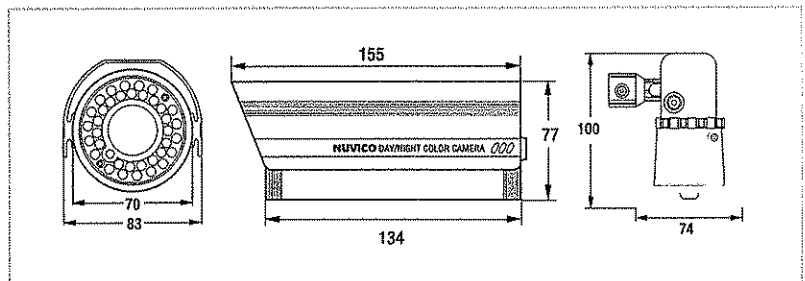

UPS

Uninterruptible Power System

Line Interactive *Network* UPS

**800VA/1000VA
1200VA/1500VA/2200VA**

USER'S MANUAL

**Printed in USA
ABC**

Important safety instructions

Thank you for selecting this uninterruptible power system (UPS). It provides you with better protection for connected equipment.

Please read this manual!

This manual provides safety, installation and operating instructions that will help you derive the fullest performance and service life that the UPS has to offer.

Please save this manual!

It includes important instructions for the safe use of this UPS and for obtaining factory service should the proper operation of the UPS come into question.

Please save or recycle the packaging materials!

The UPS's shipping materials were designed with great care to provide protection from transportation related damage. These materials are invaluable if you ever have to return the UPS for service. Damage sustained during transit is not covered under the warranty.

Table of contents

1	Introduction	1
2	Safety	2
3	Presentation	3
4	Front Panel	3
5	Rear Panel	4
6	Installation	5
7	Operation	7
8	Alarms	8
9	Software Options	9
10	Computer Interface Port	10
11	Battery replacement	11
12	Troubleshooting	12
13	Storage	12
14	Specifications	13

1. INTRODUCTION

The product is line interactive UPS with the newest technology and powerful function. The LINE INTERACTIVE UPS is with AVR function allows input voltage range from 75% to 125%, including on line voltage boost-up & buck down. An ideal protection equipment for critical connected loads. It is based on microprocessor controls, with utility power connected, the charging is ongoing, no need to switch ON the UPS and at back-up mode, UPS can be automatically turned OFF if none of the connected loads is operating to save the battery energy. The indicator will be ON when battery needs replacement and a cyclic self-testing function is included in order to verify both the operation of the UPS and the condition of the battery.

In addition, This UPS provides advanced single telephone line or modem surge suppression through the modular connectors on the back panel.

The LINE INTERACTIVE UPS and RUPS series monitoring software (optional kits) makes your computer operate intelligent and provides you with the ability of perfect protection of your critical devices.

Note: There is no guarantee that interference to radio/TV will not occur in a particular installation. If this UPS causes interference to radio or television reception, which can be determined by turning the UPS off and on, the user is encouraged to try to correct the interference by one or more of following measures:

- ***connect the equipment to an outlet on a circuit different from that to which the receiver is connected***
- ***increase the separation between the equipment and the receiver***
- ***reorient the receiving antenna***

2. Safety

CAUTION !

- To reduce the risk of electric shock, disconnect the UPS from the mains supply before installing a computer interface signal cable. Reconnect the power cord only after signaling interconnections have been made.
- The internal energy source(the battery) cannot be de-energized by the user. The output may be energized when the unit is not connected to a mains supply.
- The right way to de-energize the UPS properly in an emergency is to move the I/O switch to the OFF position and disconnect the power cord from the mains supply.
- The socket-outlet shall be installed near the equipment and easily accessible.
- Attention, hazardous through electric shock. Also with disconnection of this unit the main, hazardous voltage still may be accessible through supply from battery. The battery supply should be therefore disconnected in the plus and minus pole when maintenance of service work inside the UPS is considered.
- Do not dispose of batteries in a fire, the battery may explore.
- Do not open or mutilate the battery, released electrolyte is harmful to the skin and eyes.
- A battery can present a risk of electric shock and high short circuit current. The following precaution should be observed when working on batteries
 - Remove watches, rings or other metal objects.
 - Use tools with insulated handles.

Caution: Risk of electric shock - hazardous live parts inside this unit are energized from the battery supply even when the input AC power is connected.

Caution: Risk of electric shock, do not remove cover. No user serviceable parts inside, Refer servicing to qualified service personnel.

Warning: To reduce the risk of fire, replace only with the same type and rating of fuse.

Warning: To reduce the risk of fire or electric shock, install in temperature and humidity controlled indoor area of conductive contaminants.

3. Presentation

FRONT PANEL

3.1 "REPLACE BATTERY" indicator (RED LED)

The LED illuminates when the UPS's battery is no longer useful and must be replaced.

3.2 "BUCK AVR (VOLTAGE REDUCTION)" indicator (YELLOW LED)

The LED illuminates when the UPS is correcting a high utility voltage condition. The loads receive normal power.

3.3 "BACK UP" indicator (YELLOW LED)

The LED illuminates when the UPS is supplying battery power to the loads.

3.4 "BOOST AVR (VOLTAGE BOOST)" indicator (YELLOW LED)

The LED illuminates when the UPS is correcting a low utility voltage condition. The loads receive normal power.

3.5 "LINE NORMAL" indicator (GREEN LED)

3.6 "ON/OFF/TEST/SILENCE" button

Press the button more than 2 seconds to turn the UPS on or off, press the button less than 1 second to activate the UPS's self-testing or silence the back up alarm.

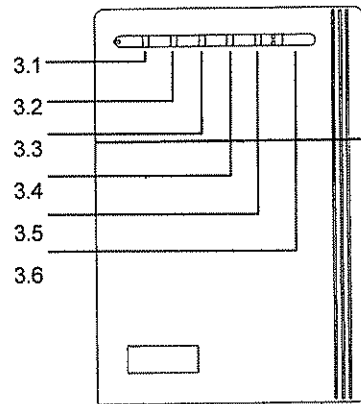

800VA/1000VA/1200VA/1500VA/2200VA

REAR PANEL

3.10 MAIN SWITCH

3.11 REMOTE PORT (COMPUTER INTERFACE)

Provide both RS-232 and relay signal to support NOVELL, UNIX, DOS, WINDOWS and other operating systems.

3.12 TEL./MODEM SURGE PROTECTION

Surge protection for telephone and modem line to have the complete safety connection for INTERNET service.

3.13 SITE WIRING FAULT INDICATORS (RED LED)

It comes on when the UPS is connected to an improperly wired AC power outlet.

Note: This device is available on 110 Vac model only.

3.14 SURGE PROTECTION OUTLET

The full time surge protection outlet provides protection from surges such as those created by lighting or connected equipment which has high initial current. Plug equipment that does not require power during a utility power failure into the outlet. This could include a printer, scanner, fax, audio device and power generator.

3.15 EXTERNAL BATTERY PACK CONNECTOR (optional)

Caution: Use only factory supplied or authorized connecting cable for external battery !

3.16 OUTPUT POWER RECEPTACLES

3.17 AC INPUT POWER RECEPTACLE

3.18 INPUT CIRCUIT BREAKER

It trips when the connected loads exceed the protected receptacle's capacity. The center plungers of the circuit breakers extend when tripped.

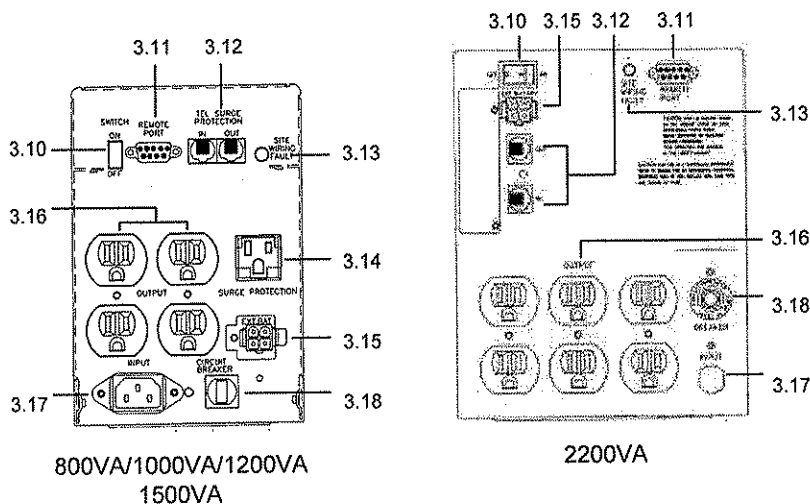

4. Installation

4.0 Inspection

Inspect the UPS upon receipt. The packaging is recyclable; save it for reuse or dispose of it properly.

4.1 Placement

Install the UPS in a protected area with adequate air flow and free of excessive dust. Do not operate the UPS where the temperature and humidity is outside the specified limits.

4.2 Connect Computer Interface (optional)

UPSMON series software (or other power management software) and an interface kits can be used with this UPS. Use only kits supplied or approved by the manufacturer. If used, connect the interface cable to the 9 pin computer interface port on the back panel of the UPS.

Note: Computer interface connection is optional. The UPS works properly without a computer interface connection.

Caution: Use only factory supplied or authorized UPS monitoring cable !

4.3 Connect external battery pack (optional)

Before connecting, make sure the external battery pack and the connector cable are compatible with this UPS.

Note: External battery connection is not necessary. The UPS works properly without a external battery pack connection.

Caution: Use only factory supplied or external battery connection cable !

4.4 Connect the telephone/modem lines (optional)

Connect a single line telephone or a modem line into the telephone/modem surge protection sockets on the back of the UPS. The RJ-45/RJ-11 modular sockets accept standard single line telephone connections. This connection will require another length of telephone cable (supplied).

Note: *This connection is optional. It is not necessary to use this UPS.*

Caution: *The telephone line current limiting feature could be rendered inoperable if improperly installed. Make sure that the telephone line from the wall is plugged into the connector marked "IN", and the device to be protected (telephone, modem, etc.) is plugged into the connector marked "OUT".*

Caution: *This surge protection device is for indoor use only and never install telephone wiring during a lightning storm.*

4.5 Connect to Utility

Connect the AC input power connector to utility power to power up the UPS.

4.6 Charge the battery

The UPS charges its battery whenever it is connected to utility power. For best results, charge the battery for 4 hours in the initial use.

4.7 Connect the loads

Plug the loads into the output connectors on the rear of the UPS. To use the UPS as a master on/off switch, make sure all of the loads are switched on.

Caution: *Never connect a laser printer or plotter to the UPS with other computer equipment. A laser printer or plotter periodically draws significantly more power than when idle, and may overload the UPS.*

4.8 Check the Site Wiring Fault Indicator

After plugging in the loads and the UPS, check the site wiring fault indicator on the rear panel. See section 3.17 for location of the indicator on the back panel. It lights if the UPS is plugged into an improperly wired AC power outlet. Wiring faults detected include ground, hot-neutral polarity reversal, and overloaded neutral circuit.

Note: *This device is available on 110 Vac model only.*

5. Operation

5.1 Switch on

With the UPS plugged in, turn on MAIN SWITCH (on rear panel) and press ON/OFF/TEST/SILENCE button (on front panel) less than 2 seconds to switch the UPS on. The UPS will perform self-testing each time when it is switched on.

Note: When switched off the UPS maintains the battery charge and will respond to commands received through the computer interface port.

5.2 Switch off

By pressing and holding ON/OFF/TEST/SILENCE button until the "LINE NORMAL" or "BACK UP" LED off. To save battery power, turn off MAIN SWITCH (on rear panel) if you leave the UPS along over one day.

5.3 Self-test

Use the self-test to verify both the operation of the UPS and the condition of the battery. In normal utility power, push the ON/OFF/TEST/SILENCE button less than 1 second and UPS performs a self-test function. During the self-test, the UPS operates a back up mode.

Note: During the self-test, the UPS briefly operates the loads on-battery (the on-battery LED comes on).

If the UPS passes the self-test, it returns to on-line operation. The on-battery LED does off and the on-line LED goes on steady.

If the UPS fails the self-test it immediately returns to on-line operation and lights the replace battery LED. The loads are not affected. Recharge the battery overnight and perform the self-test again. If the replace battery LED is still on, ask our nearest dealer to replace battery.

5.4 Silence

In "BACK UP" mode, push ON/OFF/TEST/SILENCE less than 1 second to silence the audible alarm. (The function is void when under condition of "LOW BATTERY" or "OVERLOAD")

Note: At back-up mode, UPS can be automatically turned off if none of the connected loads is operating.

5.5 Cold start

When the UPS is off and there is no utility power, use the cold start feature to apply power to the loads from UPS's battery. Press the ON/TEST button (see section 3.1 for location of the indicator on the front panel) until the UPS beeps.

5.6 Shutdown mode

In shutdown mode the UPS stops supplying power to the load, waiting for return of utility power. If there is no utility power present, external devices (e.g., servers) connected to the computer interface can command the UPS to shutdown. This is normally done to preserve battery capacity after the graceful shutdown of protected servers. The UPS will scroll the front panel indicators sequentially in shutdown mode.

6. Alarm

6.1 "BACK UP" (slow alarm)

When in BACK UP mode, the YELLOW LED illuminates and the UPS sounds an audible alarm. The alarm stops when the UPS returns to LINE NORMAL operation.

Press the ON/OFF/TEST/SILENCE button during on-battery alarms to stop the beeping.

6.2 "LOW BATTERY" (rapid alarm)

In BACK UP mode, when the battery energy runs low, the UPS beeps rapidly until the UPS shuts down from battery exhaustion or returns to LINE NORMAL operation.

6.3 "OVERLOAD" (continuous alarm)

When the UPS is overloaded (the connected loads exceed the maximum rated capacity) the UPS emits continuous alarm to warn a overload condition. Disconnect nonessential load equipment from UPS to eliminate the overload.

6.4 "REPLACE BATTERY" (continuous alarm)

The UPS emits continuous beeps and the REPLACE BATTERY LED illuminates if the battery fails the self-test. See section 9 to replace battery by yourself or call your dealer for services.

7. Software options

7.1 Power Monitoring Software

The UPSMON series software (or other power monitoring software) is applied standard RS-232 interface to perform monitoring functions, and then provides an orderly shutdown of a computer in the event of power failure. Moreover, UPSMON displays all the diagnostic symptoms on monitor, such as Voltage, Frequency, Battery level and so on..

The software is available for DOS, Windows 3.1x, Windows 95, Windows NT V3.5 or later, Novell Netware and others. Call your dealer for more information on computer OS compatible solutions.

7.2 Interface Kits

A series of interface kits is available for operation systems that provide UPS monitoring. Each interface kit includes the special interface cable required to convert status signals from the UPS into signals which individual operating system recognize. The interface cable at UPS side must be connected to REMOTE PORT , at computer side can be either COM 1 or COM 2. The other installation instructions and powerful features please refer to READ.ME file.

Caution: Use only factory supplied or authorized UPS monitoring cable !

8. Computer Interface Port

The computer interface port has the following characteristics:

D-SUB 9 Pin Female Connector for white cable

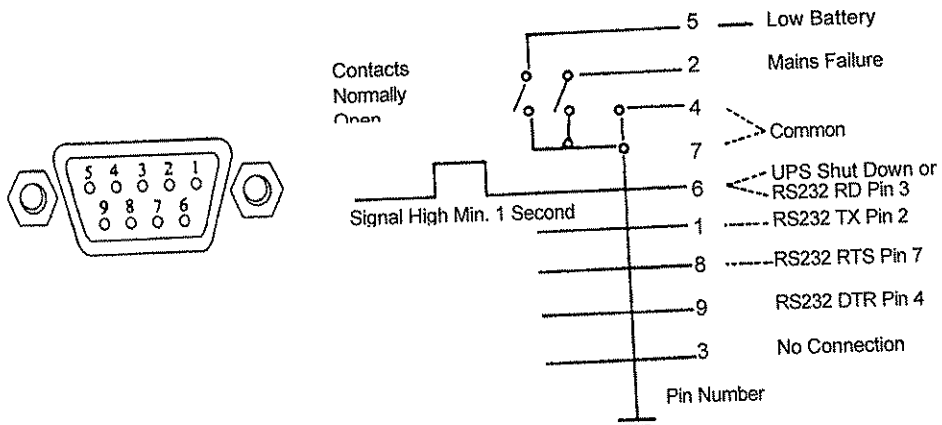

D-SUB 9 Pin Female Connector for purple cable

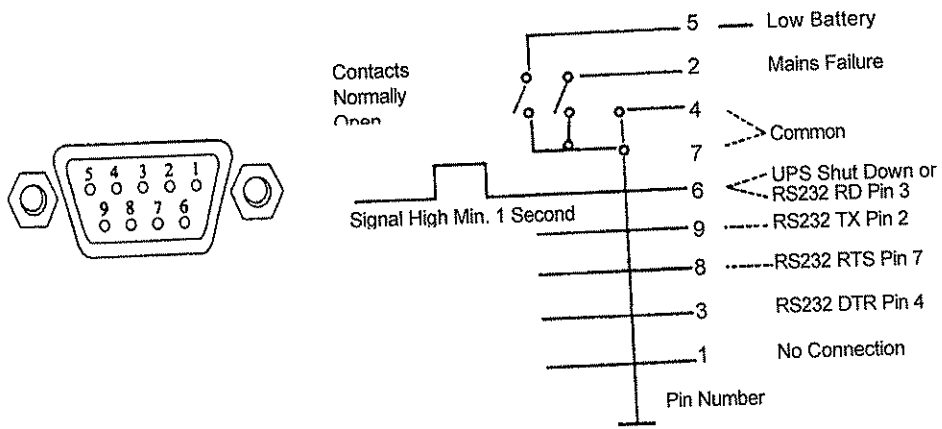

9. Battery Replacement

Your battery should run anywhere from 3-5 years before even needing to be replaced. Please follow the instructions below for easy battery replacement.

Note: When replace battery, disconnect the utility power then open the case and take notice of the battery's polarity while install the new battery to avoid short.

- 1) Unplug unit from AC power source and disconnect all connected equipment.
 - 2) Disconnect AC power cord from unit.
 - 3) Turn unit upside down and using a phillips screw driver, unscrew the 4 screws holding the top of the unit to the bottom. Put screws in a safe place for reconnection.
 - 4) Holding the top together firmly with the bottom, turn the entire unit right side up.
 - 5) Carefully lift top cover off and place to the side. The connecting wires and electronics will be exposed. Be careful not to touch any inner components when changing the battery.
 - 6) Remove the 2 connecting wires from the battery.
 - 7) You can now easily remove the battery from the unit
- Caution: Do not dispose of battery in fire.**
Caution: Do not attempt to open the battery.
Caution: The following precautions should be taken when replacing the battery
- remove watches, rings, etc...
 - use tools with insulated handles
- 8) Place your new battery in the same position/direction and reconnect the wires red wire-position(+) and black wire negative(-)
 - 9) Please follow steps 5,4 and 3 (in that order) to reconnect the entire unit.
 - 10) Please follow manual instructions in order to properly reconnect your equipment.

10. Troubleshooting

PROBLEM	POSSIBLE CAUSE	ACTION TO TAKE
UPS not on LED not light	On/off/test/silence button not pushed or push too short	Press the on/off/test/silence button more than 1 second
	Battery voltage less than 10V	Recharge the ups at least 4 hours
	PCB failure	Replace the PCB, call for service
	Load less than 20W at battery mode	Normal condition
UPS always at battery mode	Power cord lose	Replug the power cord
	AC FUSE burn out	Replace the AC fuse
	Line voltage too high, too low or black out	Normal condition
	PCB failure	Replace PCB, call for service
Back up time too short	battery not fully charged	Recharge the UPS at least 4 hours
	PCB failure	Replace PCB, call for service
Buzzer continuous beeping	Overload	Remove the noncritical loads
RED LED light	Battery failure	Replace battery, call for service

12. Specifications

MODEL		KIN 800AP	KIN 1000AP	KIN 1200AP	KIN 1500AP	KIN 2200AP
INPUT	Capacity	800VA	1000VA	1200VA	1500VA	2200VA
	Voltage	+/-25% at line input				
	Frequency	50 or 60Hz +/-10% (auto sensing)				
OUTPUT	Voltage (on battery)	Simulated sine wave at 100V/110/115V/120V/220V/230V/240V +/-5%				
	Frequency (on battery)	50 or 60Hz +/-0.5%				
	Voltage Regulation AVR	AVR automatically increase output voltage 15% above input voltage if -9% to -25% of nominal. AVR decrease output voltage 13% below input voltage if +9% to +25% of nominal				
	Transfer time	2/4 milliseconds, including detection time				
PROTECTION And FILTERING	Spike Protection	320 Joules, 2ms				
	EMI/RFI filter	10dB at 0.15MHz, 50dB at 30MHz (for xxxAP models only)				
	Overload Protection	UPS automatic shutdown if overload exceeds 110% of nominal at 60 second and 130% at 3 seconds.				
	Unit Input	Circuit breaker for overload & short circuit protection				
	10Base-T Cable Port	Network (UTP, RJ-45) compatible jacks				
	Short Circuit	UPS output cut off immediately or input circuit breaker protection				
BATTERY	Type	Sealed, maintenance-free lead acid batteries With 3-6 years typical lifetime				
	Typical Recharge Time	4 hours (to 90% of full capacity)				
	Protection	Automatic self-test & Discharge protection, Replace battery indicator				
PHYSICAL	Back up Time	10 - 30 minutes (depending on computer load)				
	Net Weight Kg(lbs)	13 (28.6)	15 (33.0)	15.2 (33.4)	15.6 (34.3)	26.2 (57.6)
	Shipping Weight Kg(lbs)	14.2 (31.2)	16.2 (35.6)	16.4 (36.1)	16.8 (36.9)	28.2 (62)
	Dimension(mm) WxDxH	130 x 382 x 201				169 x 448 x 227
ALARM	Input Inlet	IEC 320 power inlet				
	Battery Back-Up	Slow beeping sound (about 0.47Hz)				
	Battery Low	Rapid beeping sound (about 1.824Hz)				
	Overload	Continue beeping sound				
INTERFACE	RS-232 Interface	Bi-directional communication port				
CONFORMANCE	Safety	Meet IEEE 587 standard				
	Surge	cUL, TUV, CE, meet FCC				
ENVIRONMENT	Ambient operation	3,500 meters max. elevation, 0-95% humidity non-condensing 0-48 deg C				
	Audible noise	<48dBA (1 meter from surface)				
	Storage condition	15000 meters max. elevation				

© 1999 Powercom Co., Ltd. All right Reserved. All trademarks are property of their respective owners. Specifications subject to change without notice.