



State of West Virginia
 Department of Administration
 Purchasing Division
 2019 Washington Street East
 Post Office Box 50130
 Charleston, WV 25305-0130

Request for Quotation

RFO NUMBER
MOC26997

PAGE
1

ADDRESS CORRESPONDENCE TO ATTENTION OF
**JOHN ABBOTT
 304-558-2544**

RFQ COPY
 TYPE NAME/ADDRESS HERE

VENDOR

**Kamran & Company, Inc.
 411 East Montecito St.
 Santa Barbara, CA 93101
 (805) 963-3016 Fax (805) 962-5915**

SHIP TO

**DIVISION OF CORRECTIONS
 MOUNT OLIVE CORRECTIONAL
 CENTER
 ONE MOUNTAIN SIDE WAY
 MT. OLIVE, WV
 25185 304-442-7216**

DATE PRINTED	TERMS OF SALE	SHIP VIA	F.O.B.	FREIGHT TERMS
04/09/2009				

BID OPENING DATE: **04/28/2009** BID OPENING TIME **01:30PM**

LINE	QUANTITY	UOP	CAT NO	ITEM NUMBER	UNIT PRICE	AMOUNT
0001	2	EA		165-85		
<p>STEAM COOKERS</p> <p>CONTRACT TO PROVIDE COMMERCIAL KITCHEN STEAMERS AND TILTING KETTLES, INCLUDING INSTALLATION, FOR THE MT. OLIVE CORRECTIONAL CENTER, MT. OLIVE, WV, PER THE SPECIFICATIONS.</p> <p>ALL REQUIREMENTS LISTED IN THE ATTACHED SPECIFICATIONS ARE TO BE BID; BRAND AND MODEL NUMBERS LISTED ARE THE MINIMUM STANDARD OF QUALITY ACCEPTABLE - BIDDERS SHALL INCLUDE AN EQUAL OR SUPERIOR PRODUCT AS LISTED.</p> <p>INSTALLATION, SET-UP, & TESTING IS REQUIRED.</p> <p>REMOVAL OF THE OLD EQUIPMENT IS THE RESPONSIBILITY OF THE SUCCESSFUL VENDOR. THE OLD EQUIPMENT SHALL BE PLACED AT A DESIGNATED STORAGE AREA WITHIN THE FACILITY.</p> <p style="text-align: center;">NOTICE</p> <p>A SIGNED BID MUST BE SUBMITTED TO:</p> <p style="text-align: center;">DEPARTMENT OF ADMINISTRATION PURCHASING DIVISION BUILDING 15 2019 WASHINGTON STREET, EAST CHARLESTON, WV 25305-0130</p>						

RECEIVED
 2009 MAY -4 P 1:02
 PURCHASING DIVISION
 STATE OF WV

SEE REVERSE SIDE FOR TERMS AND CONDITIONS			
SIGNATURE <i>[Signature]</i>	TELEPHONE	DATE 4/23/09	
TITLE Estimator	FEIN 77-0301570	ADDRESS CHANGES TO BE NOTED ABOVE	

WHEN RESPONDING TO RFQ, INSERT NAME AND ADDRESS IN SPACE ABOVE LABELED 'VENDOR'

**GENERAL TERMS & CONDITIONS
REQUEST FOR QUOTATION (RFQ) AND REQUEST FOR PROPOSAL (RFP)**

1. Awards will be made in the best interest of the State of West Virginia.
2. The State may accept or reject in part, or in whole, any bid.
3. All quotations are governed by the *West Virginia Code* and the *Legislative Rules* of the Purchasing Division.
4. Prior to any award, the apparent successful vendor must be properly registered with the Purchasing Division and have paid the required \$125 fee.
5. All services performed or goods delivered under State Purchase Order/Contracts are to be continued for the term of the Purchase Order/Contracts, contingent upon funds being appropriated by the Legislature or otherwise being made available. In the event funds are not appropriated or otherwise available for these services or goods, this Purchase Order/Contract becomes void and of no effect after June 30.
6. Payment may only be made after the delivery and acceptance of goods or services.
7. Interest may be paid for late payment in accordance with the *West Virginia Code*.
8. Vendor preference will be granted upon written request in accordance with the *West Virginia Code*.
9. The State of West Virginia is exempt from federal and state taxes and will not pay or reimburse such taxes.
10. The Director of Purchasing may cancel any Purchase Order/Contract upon 30 days written notice to the seller.
11. The laws of the State of West Virginia and the *Legislative Rules* of the Purchasing Division shall govern all rights and duties under the Contract, including without limitation the validity of this Purchase Order/Contract.
12. Any reference to automatic renewal is hereby deleted. The Contract may be renewed only upon mutual written agreement of the parties.
13. **BANKRUPTCY:** In the event the vendor/contractor files for bankruptcy protection, this Contract may be deemed null and void, and terminated without further order.
14. **HIPAA BUSINESS ASSOCIATE ADDENDUM:** The West Virginia State Government HIPAA Business Associate Addendum (BAA), approved by the Attorney General, and available online at the Purchasing Division's web site (<http://www.state.wv.us/admin/purchase/vrc/hipaa.htm>) is hereby made part of the agreement. Provided that, the Agency meets the definition of a Cover Entity (45 CFR §160.103) and will be disclosing Protected Health Information (45 CFR §160.103) to the vendor.
15. **WEST VIRGINIA ALCOHOL & DRUG-FREE WORKPLACE ACT:** If this Contract constitutes a public improvement construction contract as set forth in Article 1D, Chapter 21 of the West Virginia Code ("The West Virginia Alcohol and Drug-Free Workplace Act"), then the following language shall hereby become part of this Contract: "The contractor and its subcontractors shall implement and maintain a written drug-free workplace policy in compliance with the West Virginia Alcohol and Drug-Free Workplace Act, as set forth in Article 1D, Chapter 21 of the West Virginia Code. The contractor and its subcontractors shall provide a sworn statement in writing, under the penalties of perjury, that they maintain a valid drug-free work place policy in compliance with the West Virginia and Drug-Free Workplace Act. It is understood and agreed that this Contract shall be cancelled by the awarding authority if the Contractor: 1) Fails to implement its drug-free workplace policy; 2) Fails to provide information regarding implementation of the contractor's drug-free workplace policy at the request of the public authority; or 3) Provides to the public authority false information regarding the contractor's drug-free workplace policy."

INSTRUCTIONS TO BIDDERS

1. Use the quotation forms provided by the Purchasing Division.
2. **SPECIFICATIONS:** Items offered must be in compliance with the specifications. Any deviation from the specifications must be clearly indicated by the bidder. Alternates offered by the bidder as **EQUAL** to the specifications must be clearly defined. A bidder offering an alternate should attach complete specifications and literature to the bid. The Purchasing Division may waive minor deviations to specifications.
3. Complete all sections of the quotation form.
4. Unit prices shall prevail in case of discrepancy.
5. All quotations are considered F.O.B. destination unless alternate shipping terms are clearly identified in the quotation.
6. **BID SUBMISSION:** All quotations must be delivered by the bidder to the office listed below prior to the date and time of the bid opening. Failure of the bidder to deliver the quotations on time will result in bid disqualifications: Department of Administration, Purchasing Division, 2019 Washington Street East, P.O. Box 50130, Charleston, WV 25305-0130



State of West Virginia
 Department of Administration
 Purchasing Division
 2019 Washington Street East
 Post Office Box 50130
 Charleston, WV 25305-0130

Request for Quotation

RFQ NUMBER:
MOC26997

PAGE:
2

ADDRESS CORRESPONDENCE TO ATTENTION OF:
**JOHN ABBOTT
 304-558-2544**

RFQ COPY

TYPE NAME/ADDRESS HERE

**Kamran & Company, Inc.
 411 East Montecito St.
 Santa Barbara, CA 93101
 (805) 963-3016 Fax (805) 962-5915**

SHIP TO

**DIVISION OF CORRECTIONS
 MOUNT OLIVE CORRECTIONAL
 CENTER
 ONE MOUNTAINSIDE WAY
 MT. OLIVE, WV
 25185 304-442-7216**

DATE PRINTED 04/09/2009	TERMS OF SALE	SHIP VIA	FOB	FREIGHT TERMS
BID OPENING DATE: 04/28/2009		BID OPENING TIME		01:30PM

LINE	QUANTITY	UOP	CAT. NO.	ITEM NUMBER	UNIT PRICE	AMOUNT
<p>THE BID SHOULD CONTAIN THIS INFORMATION ON THE FACE OF THE ENVELOPE OR THE BID MAY NOT BE CONSIDERED:</p> <p>SEALED BID</p> <p>BUYER: JOHN ABBOTT-----</p> <p>RFQ. NO.: MOC26997-----</p> <p>BID OPENING DATE: 4/28/2009-----</p> <p>BID OPENING TIME: 1:30 PM-----</p> <p>PLEASE PROVIDE A FAX NUMBER IN CASE IT IS NECESSARY TO CONTACT YOU REGARDING YOUR BID: ----- (805) 962-5915 -----</p> <p>CONTACT PERSON (PLEASE PRINT CLEARLY): ----- Claudia PONCE (805) 963-3016 x125 -----</p> <p>***** THIS IS THE END OF RFQ MOC26997 ***** TOTAL: \$ 65,700-</p>						

SEE REVERSE SIDE FOR TERMS AND CONDITIONS

SIGNATURE: *Claudia Ponce* TELEPHONE: **(805) 963-3016** DATE: **4/23/09**

TITLE: **Estimator** FEIN: **77-0301570** ADDRESS CHANGES TO BE NOTED ABOVE

WHEN RESPONDING TO RFQ, INSERT NAME AND ADDRESS IN SPACE ABOVE LABELED 'VENDOR'

Item #1

3

STEAMER, CONVECTION, GAS, FLOOR MODEL

Convection Steamer, gas, 2 compartment, 24" cabinet base, six 12 x 20 x 2-1/2" pan/compartment capacity, twin gas-fired generators w/individual electronic ignition system, 190,000 BTU

Gas type to be specified

120v/60/1-ph

91-8852 Kleensteam, includes 2 yr. boiler warranty, 7CB5 cartridge, SS-10 scale inhibitor cartridge, (4) ScaleKleen 2.2 lb packets & dip tube

PRISON PACKAGE Consists of:

*A Lockable Stainless Steel Hinged Cover over the Cooker Controls

*Lockable Modular Cabinet Base Doors. Side and Rear Panels Secured to the SS Base Frame with Tamper Proof Screws.

*Four (4) Flanged Feet for Securing the Unit to the Floor

*All Exposed Screws to be Tamper Proof

Note: Locks are Not Included

Weight: 1510 lbs. total

One (1) Year Parts & Labor Warranty, and Free Mechanical Start-Up included in pricing.

Item #2

TILTING KETTLE, GAS

Kettle, tilting, gas, 60-gallon capacity, 2/3 steam jacket design, open leg base, all stainless steel exterior finish, 120,000 BTU

Gas type to be specified

120v/60-50/1ph, std.

08-0011 Tangent Draw-Off Valve, 3", for tilting kettles (not available on modular kettles)

09-1116 Lift-Off Cover, for 60 gallon tilting kettle

09-1125 Hinged Cover, for 60 gallon tilting kettle

PRISON PACKAGE Consists of:

*Lockable Stainless Steel Hinged Cover over the Control Panel **Lock Not Included

*All Exposed Screws will be Tamper Proof Tack Welds where Applicable

Weight: 2000 lbs. total

One (1) Year Parts & Labor Warranty, and Free Mechanical Start-Up included in pricing.

MOC26997 - Commercial Kitchen Equipment - BID FORM		
Description	Order Qty.	Extended Price
Convection Steamer	2	\$ 23,900.-
Tilting Kettle	2	\$ 41,800.-
Failure to use this form may result in disqualification		\$ 65,700.-
Bidder / Vendor Information:		
Name:	Kamran and Company, Inc	
Address:	411 E. Montecito St.	
	Santa Barbara, CA 93101	
Phone# :	(805) 963-3016 x125	
Email Address:	Claudia@kamrand.com	

VENDOR PREFERENCE CERTIFICATE

Certification and application* is hereby made for Preference in accordance with West Virginia Code, §5A-3-37. (Does not apply to construction contracts). West Virginia Code, §5A-3-37, provides an opportunity for qualifying vendors to request (at the time of bid) preference for their residency status. Such preference is an evaluation method only and will be applied only to the cost bid in accordance with the West Virginia Code. This certificate for application is to be used to request such preference. The Purchasing Division will make the determination of the Resident Vendor Preference, if applicable.

- 1. Application is made for 2.5% resident vendor preference for the reason checked: Bidder is an individual resident vendor and has resided continuously in West Virginia for four (4) years immediately preceding the date of this certification; or, Bidder is a partnership, association or corporation resident vendor and has maintained its headquarters or principal place of business continuously in West Virginia for four (4) years immediately preceding the date of this certification; or 80% of the ownership interest of Bidder is held by another individual, partnership, association or corporation resident vendor who has maintained its headquarters or principal place of business continuously in West Virginia for four (4) years immediately preceding the date of this certification; or, Bidder is a nonresident vendor which has an affiliate or subsidiary which employs a minimum of one hundred state residents and which has maintained its headquarters or principal place of business within West Virginia continuously for the four (4) years immediately preceding the date of this certification; or,
2. Application is made for 2.5% resident vendor preference for the reason checked: Bidder is a resident vendor who certifies that, during the life of the contract, on average at least 75% of the employees working on the project being bid are residents of West Virginia who have resided in the state continuously for the two years immediately preceding submission of this bid; or,
3. Application is made for 2.5% resident vendor preference for the reason checked: Bidder is a nonresident vendor employing a minimum of one hundred state residents or is a nonresident vendor with an affiliate or subsidiary which maintains its headquarters or principal place of business within West Virginia employing a minimum of one hundred state residents who certifies that, during the life of the contract, on average at least 75% of the employees or Bidder's affiliate's or subsidiary's employees are residents of West Virginia who have resided in the state continuously for the two years immediately preceding submission of this bid; or,
4. Application is made for 5% resident vendor preference for the reason checked: Bidder meets either the requirement of both subdivisions (1) and (2) or subdivision (1) and (3) as stated above; or,
5. Application is made for 3.5% resident vendor preference who is a veteran for the reason checked: Bidder is an individual resident vendor who is a veteran of the United States armed forces, the reserves or the National Guard and has resided in West Virginia continuously for the four years immediately preceding the date on which the bid is submitted; or,
6. Application is made for 3.5% resident vendor preference who is a veteran for the reason checked: Bidder is a resident vendor who is a veteran of the United States armed forces, the reserves or the National Guard, if, for purposes of producing or distributing the commodities or completing the project which is the subject of the vendor's bid and continuously over the entire term of the project, on average at least seventy-five percent of the vendor's employees are residents of West Virginia who have resided in the state continuously for the two immediately preceding years.

Bidder understands if the Secretary of Revenue determines that a Bidder receiving preference has failed to continue to meet the requirements for such preference, the Secretary may order the Director of Purchasing to: (a) reject the bid; or (b) assess a penalty against such Bidder in an amount not to exceed 5% of the bid amount and that such penalty will be paid to the contracting agency or deducted from any unpaid balance on the contract or purchase order.

By submission of this certificate, Bidder agrees to disclose any reasonably requested information to the Purchasing Division and authorizes the Department of Revenue to disclose to the Director of Purchasing appropriate information verifying that Bidder has paid the required business taxes, provided that such information does not contain the amounts of taxes paid nor any other information deemed by the Tax Commissioner to be confidential.

Under penalty of law for false swearing (West Virginia Code, §61-5-3), Bidder hereby certifies that this certificate is true and accurate in all respects; and that if a contract is issued to Bidder and if anything contained within this certificate changes during the term of the contract, Bidder will notify the Purchasing Division in writing immediately.

Bidder: _____ Signed: _____

Date: _____ Title: _____

*Check any combination of preference consideration(s) indicated above, which you are entitled to receive.

STATE OF WEST VIRGINIA
Purchasing Division

PURCHASING AFFIDAVIT

VENDOR OWING A DEBT TO THE STATE:

West Virginia Code §5A-3-10a provides that: No contract or renewal of any contract may be awarded by the state or any of its political subdivisions to any vendor or prospective vendor when the vendor or prospective vendor or a related party to the vendor or prospective vendor is a debtor and the debt owed is an amount greater than one thousand dollars in the aggregate.

PUBLIC IMPROVEMENT CONTRACTS & DRUG-FREE WORKPLACE ACT:

If this is a solicitation for a public improvement construction contract, the vendor, by its signature below, affirms that it has a written plan for a drug-free workplace policy in compliance with Article 1D, Chapter 21 of the *West Virginia Code*. The vendor **must** make said affirmation with its bid submission. Further, public improvement construction contract may not be awarded to a vendor who does not have a written plan for a drug-free workplace policy in compliance with Article 1D, Chapter 21 of the *West Virginia Code* and who has not submitted that plan to the appropriate contracting authority in timely fashion. For a vendor who is a subcontractor, compliance with Section 5, Article 1D, Chapter 21 of the *West Virginia Code* may take place before their work on the public improvement is begun.

ANTITRUST:

In submitting a bid to any agency for the state of West Virginia, the bidder offers and agrees that if the bid is accepted the bidder will convey, sell, assign or transfer to the state of West Virginia all rights, title and interest in and to all causes of action it may now or hereafter acquire under the antitrust laws of the United States and the state of West Virginia for price fixing and/or unreasonable restraints of trade relating to the particular commodities or services purchased or acquired by the state of West Virginia. Such assignment shall be made and become effective at the time the purchasing agency tenders the initial payment to the bidder.

I certify that this bid is made without prior understanding, agreement, or connection with any corporation, firm, limited liability company, partnership or person or entity submitting a bid for the same materials, supplies, equipment or services and is in all respects fair and without collusion or fraud. I further certify that I am authorized to sign the certification on behalf of the bidder or this bid.

LICENSING:

Vendors must be licensed and in good standing in accordance with any and all state and local laws and requirements by any state or local agency of West Virginia, including, but not limited to, the West Virginia Secretary of State's Office, the West Virginia Tax Department, West Virginia Insurance Commission, or any other state agencies or political subdivision. Furthermore, the vendor must provide all necessary releases to obtain information to enable the Director or spending unit to verify that the vendor is licensed and in good standing with the above entities.

CONFIDENTIALITY:

The vendor agrees that he or she will not disclose to anyone, directly or indirectly, any such personally identifiable information or other confidential information gained from the agency, unless the individual who is the subject of the information consents to the disclosure in writing or the disclosure is made pursuant to the agency's policies, procedures and rules. Vendor further agrees to comply with the Confidentiality Policies and Information Security Accountability Requirements, set forth in <http://www.state.wv.us/admin/purchase/privacy/noticeConfidentiality.pdf>.

Under penalty of law for false swearing (*West Virginia Code* §61-5-3), it is hereby certified that the vendor affirms and acknowledges the information in this affidavit and is in compliance with the requirements as stated.

Vendor's Name: Lamvan & Co. Inc.
 Authorized Signature: [Signature] Date: 4/23/09



STEAMCRAFT® GENERATOR STYLE HIGH SPEED CONVECTION STEAMERS

Project _____
 Item _____
 Quantity _____
 FCSI Section _____
 Approval _____
 Date _____

SteamCraft® Gemini™ 6

SHORT SERIES PRESSURELESS STEAMER,
TWIN, INDEPENDENT GAS-FIRED GENERATORS

MODEL: 24CGA6.2S

Cleveland Standard Features

- 54.5" (1385mm) height to top of upper compartment (lower height makes maintenance easier by lowering the descaling ports)
- Each compartment has cooking capacity for 3 each 12" x 20" x 2½" Steam Table Pans
- Doors hinged left and the controls on the right
- High efficiency independent Power Burner Steam Generators 50,000 BTU's for each compartment
- Each steam-cooking compartment is independently operated and controlled by a separate stainless steel steam generator, gas valve, Power On/Off Control Levers and a Exclusive, Remote Probe-Type Water Level Control
- Easy Access Cleaning Port: Each generator has a delimiting port located on the outside, top of the unit
- Generator Cleaning Light for each compartment warns the operator to delime generator
- Generator Steam Standby Mode: Holds generator at a steaming temperature, allows unit to start cooking quickly
- Each compartment has one, 60-Minute Electro-Mechanical Timer with "SureCook" load compensating feature. Manual Bypass Switch for constant steaming.
- Durable 14 Gauge, 304 Stainless Steel construction for compartment door, cooking cavity and steam generator
- Exclusive Gemini Drain/Power Control System:
Manual 1/2 inch "Ball Valve" type drain that controls main power On/Off and automatically fills generator (located on the control panel)
- Exclusive Brass Steam Jets distribute steam even throughout cooking compartment
- Easy, Front -Access Generator Controls comes with a pullout drawer for simple servicing of unit
- 6" Stainless Steel Adjustable Legs with Flanged Feet
- Approvals: CSA (AGA, CSA) and U.L./NSF#4
- Compartment Steam Shut-Off Switch when compartment door is opened

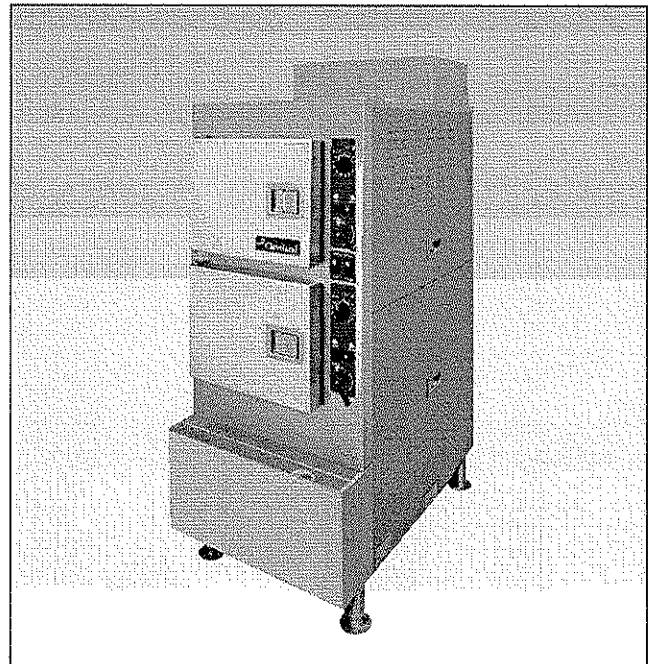

Short Form Specifications

Cleveland SteamCraft® Gemini™ Model 24CGA6.2S, 54.5" high, Two compartment steamer. Independent steam generators, 50,000 BTU's input per compartment. "SureCook" electro mechanical timer with load compensating feature. Gas valve and water level control system. Exclusive remote probe-type water level controls. Exclusive Brass "Steam Jet" distribution system. Two-piece free-floating compartment door. 14 gauge stainless steel cavity and door. Pullout service drawer for controls and Gemini Drain/Power Control System.

Options & Accessories

- Electronic Timer with Compensating Feature (ETC)
- On/Off Steam Switch Controls, no timer (MC)

- Propane Gas (PG)
- Dissolve® Descale Solution, 6 one gallon container w/quart markings (106174)
- Water Filters

- Basic Correctional Package
 - Kleensteam water filters
 - 99 base frame

SECT. IV PAGE 11
1007

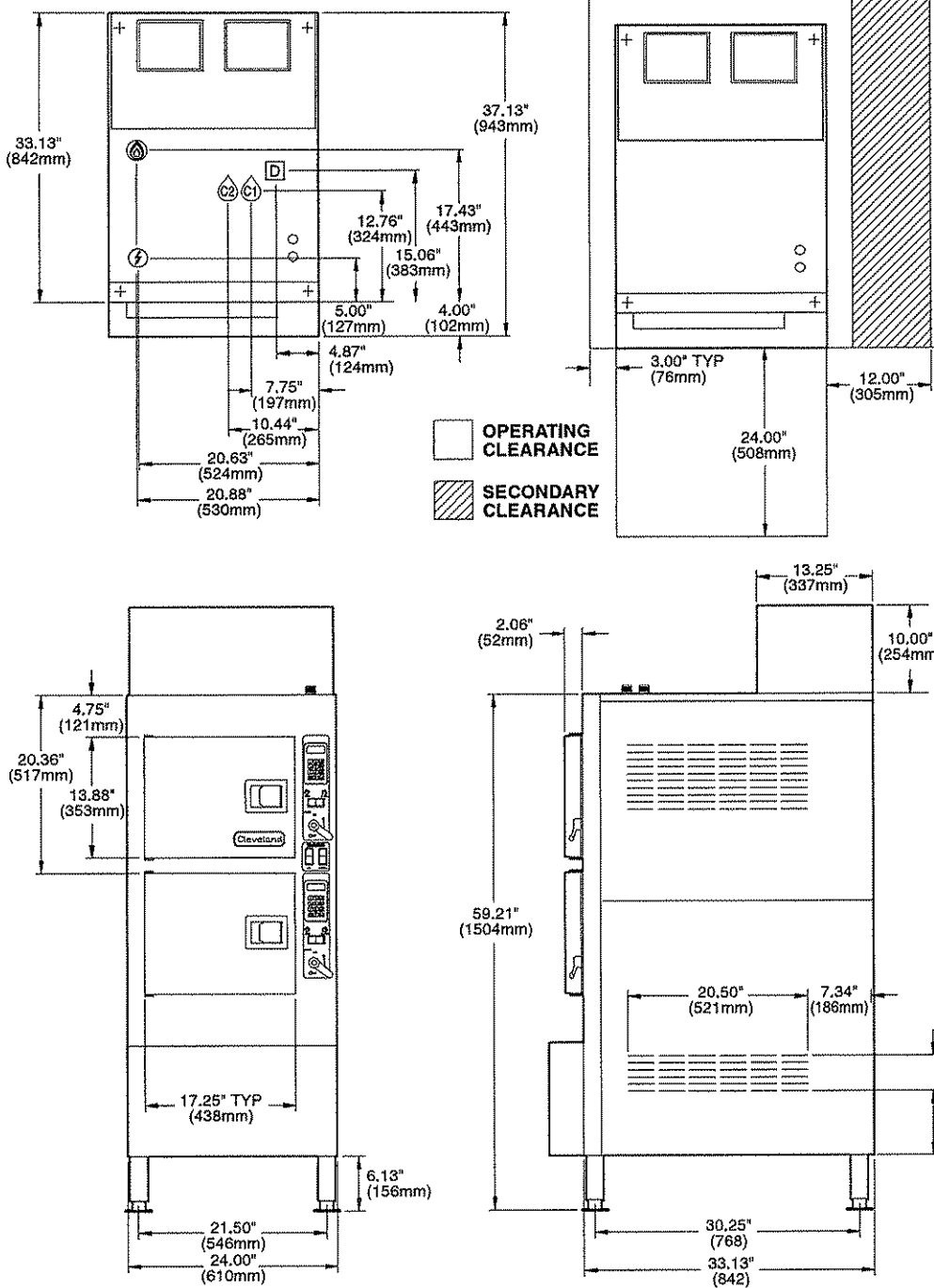

WATER QUALITY REQUIREMENTS

The quality of water varies greatly from region to region. Steam equipment generators must be drained daily and chemically descaled periodically to ensure proper operation. To minimize service problems caused by the accumulation of minerals and chemicals in water review the following quality guidelines with a local water treatment specialist. Inlet water that is beyond these specified guidelines should be treated to achieve these acceptable limits. Total Dissolved Solids less than 60 ppm, Alkalinity less than 20 ppm, Silica less than 13 ppm, pH factor greater than 7.5, Chlorine less than 30 ppm.

- Each Compartment has Capacity for:
- Three 2½" x 12" x 20" Steam Table Pans
 - Six 1" x 12" x 20" Steam Table Pans
 - Two 4" x 12" x 20" Steam Table Pans

Ⓔ GAS			⚡ ELECTRIC	Ⓒ COLD WATER	CLEARANCE	Ⓓ DRAINAGE
1½" IPS line size, ¾" connection			120V-1Phase, 60 Hz.	35 psi minimum	Right - 3", Left - 3", Rear - 3"	1½" dia.
NATURAL	PROPANE	BTU	2 Blowers & Controls	60 psi maximum	(12" on control side if adjoining wall or equipment is over 30" high for service access)	Do not connect other units to this drain
Piping ¾" N.P.T.	Piping ¾" N.P.T.	50,000 each	150 watts each	C2 ½" dia. NPT for Generator	Contact factory for variances to clearances.	Drain must not be located beneath the steamer itself
Supply pressure	Supply pressure	Generator,	** Do not connect to GFI outlet. See note below.	C1 ¾" dia. NPT for Condenser		Preferred floor drain location should be a minimum distance (from the unit) of at least 12" from the left side, 12" from the right side, 6" from the front and 6" from the rear
4.50" W.C. Min.	11.00" W.C. Min.	100,000 total				Do not use PVC pipe
14.00" W.C. Max.	14.00" W.C. Max.					
Manufacturer must be notified if unit will be used above 2,000 feet						

NOTES:
 **DO NOT CONNECT TO GFI OUTLET. CLEVELAND RANGE RECOMMENDS GAS FIRED 120 VOLT STEAMERS BE HARD WIRED DIRECTLY TO ELECTRICAL SYSTEM.
 Cleveland Range reserves right of design improvement or modification, as warranted.
 Many regional, state and local codes exist and it is the responsibility of the owner and installer to comply with the codes.
 Cleveland Range equipment is built to comply with applicable standards for manufacturers. Included among those approval agencies are UL/NSF#4 and CSA (AGA, CGA).



GAS KETTLES

Project _____
 Item _____
 Quantity _____
 FCSI Section _____
 Approval _____
 Date _____

LEG TYPE, GAS-FIRED KETTLES

TILTING, 2/3 STEAM JACKETED

"SPLASH PROOF SERIES"

40, 60, or 80 GALLONS (150, 225, or 300 LITERS)

Cleveland Standard Features

- High efficiency Power Burner Heating System (62% to 65% efficiency)
- Fast Heat-up and Recovery Time, 140M BTU's on 40 gallon models, 190M BTU's on 60 gallon and larger
- Insulated Heat Exchanger
- Automatic Ignition System
- Steam Jacket permanently filled with treated, distilled water. Venting and/or refilling not required.
- Solid State Controls, for Temperature and Low Water Safety, in a plug-in Control Module
- Control Panel includes:
 - Precise, consistent temperature control: less than $\pm 1^{\circ}\text{C}$ variance (ideal for simmering).
 - L.E.D. Indicators for Heat Cycle and Low Water Warning.
 - Power "on/off" Switch
- Front mounted combination Pressure/Vacuum Gauge
- Type 304 Stainless Steel with #4 finish on kettle and supports
- Tilt Mechanism of roller bearings and case hardened self-locking worm and segment gear
- Support Legs with level adjustable feet, flanged for floor bolting
- 50 psi Steam Jacket Rating and Safety Valve
- Standard voltage is 115 volts, 60 Hz, single-phase, supplied with cord and plug
- Standard for natural gas operation
- Typical approvals include AGA, CSA, CE, NSF and ASME

Options & Accessories

- Type 316 Stainless Steel Kettle Liner for high acid food products (316)
- Pan Carrier (PCK)
- Flow Diverter (FD)
- Food Strainer (FS)
- Kettle Markings (KM)
- Cooking Baskets and Tri-Basket Supports (BS and TBS)
- Drain Strainers (DS-)
- Faucet Mounting Bracket (FBKT)
- 2" or 3" diameter Tangent Draw-Off Valve with Drain Strainer (TD2 or TD3*), *TD3 for 60 and 80 gallon only and will raise height of kettle by 5-5/8" (143mm)
- 3" diameter Butterfly Valve (BV3)

MODELS: KGL-40-T KGL-80-T
 KGL-60-T

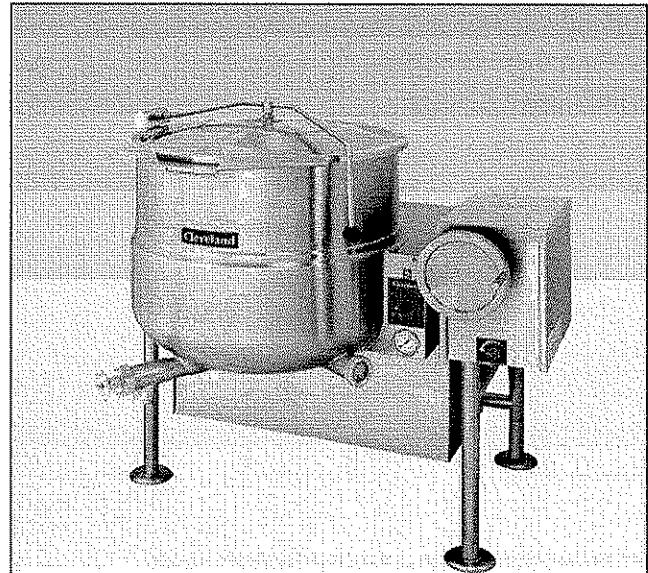

Shown with optional Spring Assisted Cover and 2" Tangent Draw-Off Valve

Short Form Specifications

Shall be CLEVELAND, Gas-Fired Tilting Kettle, Model KGL-____ T; _____ gallons, 2/3 Steam Jacketed, Power Burner Heating System, Insulated Heat Exchanger, 50 psi Steam Jacket Rating. Infinite Variable Temperature Control, L.E.D. indicators for Heat Cycle and Low Water Warning, Automatic Ignition System.

- Spring-assisted, hinged, rotatable, domed Stainless Steel Cover (CHS-)
- Hot and Cold Water Faucet with Swing Spout (DPK)
- Kettle Accessory Kit (KAK) includes:
 - Clean-up Brush (CB)
 - 36" Kettle Paddle (KP)
 - 36" Kettle Whip (KW)
 - 36" Kettle Brush (KB)
 - Draw-off Brush (DB)
 - 24 oz. Ladle (KL)
- Automatic Water Meter (GMF or LMF)
- Measuring Strip (MS)
- Option for Propane Gas operation
- Correctional Package
- Heat Deflector Shield (HS001)

SECT. IX, PAGE 7
0707

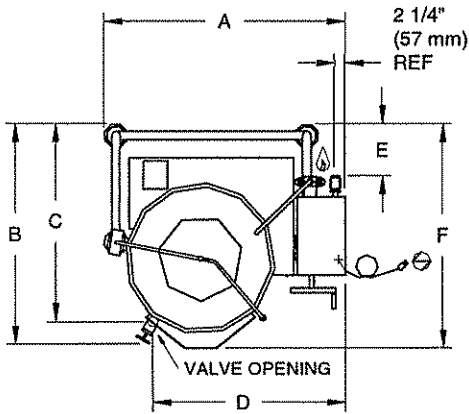

NOTE: TD3, 3" tangent draw off will raise height of kettle by 5-5/8" (143mm). Available on 60 & 80 gallon models only.

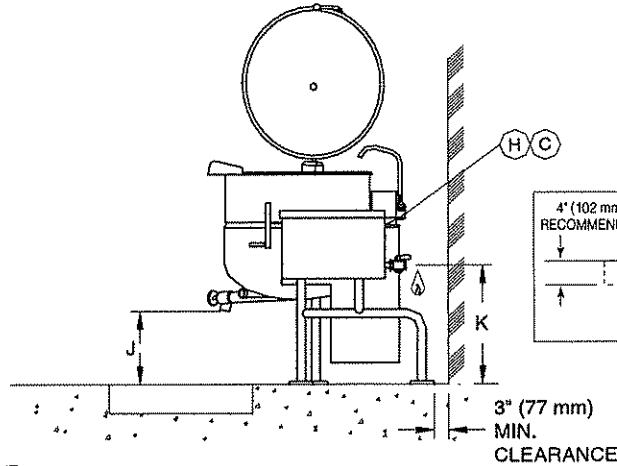
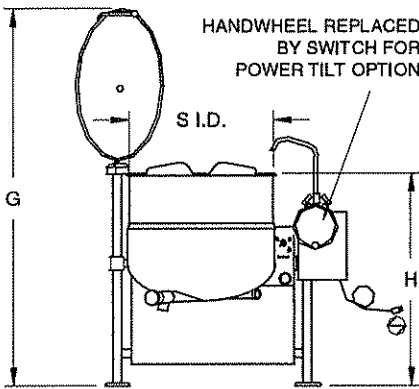
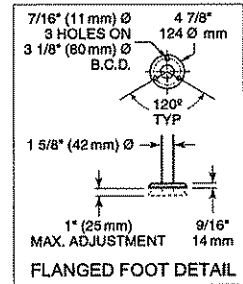
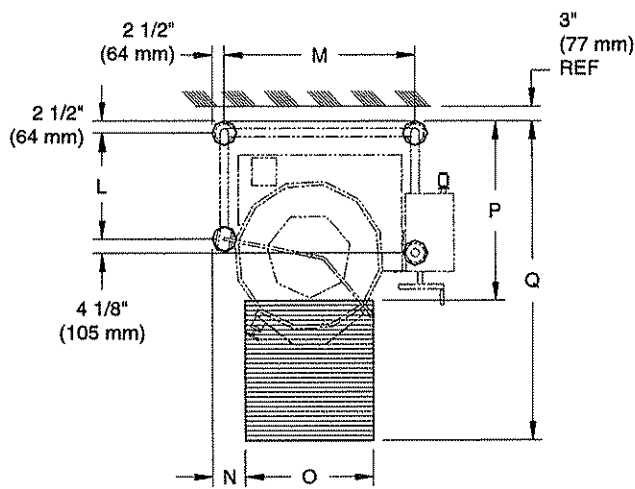

UNIT SHOWN WITH OPTIONAL 2" TANGENT DRAW-OFF VALVE, SPRING ASSIST COVER AND HOT & COLD WATER FAUCET.

CAPACITIES: (in 8 oz. servings, other sizes may be calculated)
 40 Gallon / 150 liters ... 640 servings
 60 Gallon / 225 liters ... 960 servings
 80 Gallon / 300 liters ... 1280 servings

DIMENSIONS

GALS/ LITERS	A	B	C	D	E	F	G	H	J	K	L	M	N	O	P	Q	S.I.D.
40	IN 45 3/4	42 1/2	38	35	9	42 1/4	71	40 1/2	15 1/2	23 1/4	19	35 3/4	4 3/8	24	33	63	26
150	mm 1163	108	966	889	229	1074	1804	1029	394	591	483	909	112	610	839	1601	661
60	IN 49 3/8	46	41 1/2	37	11 3/4	47 1/4	75	43 3/4	15 1/4	24 1/2	22	39 3/8	6	28	37	68	29 1/2
225	mm 1255	1169	1055	940	299	1201	1905	1112	388	623	559	1001	153	712	940	1728	750
80	IN 53	49	44 1/2	39	14 3/4	51	78	44 3/4	14	25	25	43	7	30	40	72	33
300	mm 1347	1245	1131	991	375	1296	1982	1137	356	635	635	1093	178	762	1016	1829	839

GAS			ELECTRIC	WATER	CLEARANCE
NATURAL	PROPANE	B.T.U. RATING	120V-1 Phase, 60 Hz, 10 amps	1/2" dia. Soft Copper Tubing (each) When ordered with optional faucet.	RIGHT = 0" LEFT = 0" REAR = 3" Allow 6" space minimum from rear and sides when located near combustible walls. 12" recommended on right side for service
Piping: 1/2" N.P.T.	Piping: 3/8" N.P.T.	40 gal. 140,000			
Supply pressure: 4.00" W.C. minimum 14.00" W.C. maximum	Supply pressure: 4.90" W.C. minimum 14.00" W.C. maximum	60 gal. 190,000 80 gal. 190,000			
Manufacturer must be notified if unit will be operated above 2,000 ft. altitude.					

NOTES:

Cleveland Range reserves right of design improvement or modification, as warranted.
 Many regional, state and local codes exist and it is the responsibility of the owner and installer to comply with the codes.
 Installation of backflow preventers, vacuum breakers and other specific code requirements is the responsibility of the owner and installer.
 Cleveland Range equipment is built to comply with applicable standards for manufacturers. Included among those approval agencies are U.L., A.G.A., NSF, ASME/N.B.d., CSA, CGA, ETL and others.



State of West Virginia
 Department of Administration
 Purchasing Division
 2019 Washington Street East
 Post Office Box 50130
 Charleston, WV 25305-0130

Request for Quotation

RFQ NUMBER
 MOC26997

PAGE
 1

ADDRESS CORRESPONDENCE TO ATTENTION OF
 JOHN ABBOTT
 304-558-2544

VENDOR

RFQ COPY
 TYPE NAME/ADDRESS HERE

Kamran & Company, Inc.
 411 East Montecito St.
 Santa Barbara, CA 93101
 (805) 963-3016 Fax (805) 962-5915

SHIP TO

DIVISION OF CORRECTIONS
 MOUNT OLIVE CORRECTIONAL
 CENTER
 ONE MOUNTAINSIDE WAY
 MT. OLIVE, WV
 25185 304-442-7216

DATE PRINTED	TERMS OF SALE	SHIP VIA	FOB	FREIGHT TERMS
04/17/2009	Net 30		Delivered	

BID OPENING DATE: 04/28/2009 BID OPENING TIME: 01:30PM

LINE	QUANTITY	UOP	CAT NO	ITEM NUMBER	UNIT PRICE	AMOUNT
0001	2	EA		165-85		
<p>ADDENDUM #01</p> <p>THIS ADDENDUM IS ISSUED TO ADD THE PREVAILING WAGE RATE DUE TO THE THE REQUIREMENT "VENDOR MUST SECURE STEAMER THE FLOOR", PER THE BELOW; AND TO ADD THE REQUIREMENT "INSTALLATION MUST BE SCHEDULED AFTER DINNER, OR 6:00 PM, IN ORDER TO AVOID DISRUPTION IN THE MEAL PREPARATION. GAS HOOK UP WILL BE PERFORMED BY AGENCY STAFF.</p> <p>STEAM COOKERS</p> <p>EXHIBIT 5</p> <p>WEST VIRGINIA CODE 21-1D-5 PROVIDES THAT: ANY SOLICITATION FOR A PUBLIC IMPROVEMENT CONSTRUCTION CONTRACT REQUIRES EACH VENDOR THAT SUBMITS A BID FOR THE WORK TO SUBMIT AT THE SAME TIME AN AFFIDAVIT OF COMPLIANCE WIT THE BID. THE ENCLOSED DRUG-FREE WORKPLACE AFFIDAVIT MUST BE SIGNED AND SUBMITTED WITH THE BID AS EVIDENCE OF THE VENDOR'S COMPLIANCE WITH THE PROVISIONS OF ARTICLE 1D, CHAPTER 21 OF THE WEST VIRGINIA CODE. FAILURE TO SUBMIT THE SIGNED DRUG-FREE WORKPLACE AFFIDAVIT WITH THE BID SHALL RESULT IN DISQUALIFICATION OF SUCH BID.</p> <p>NOTICE TO PROCEED: THIS CONTRACT IS TO BE PERFORMED WITHIN 30 CALENDAR DAYS AFTER THE NOTICE TO PROCEED IS RECEIVED. UNLESS OTHERWISE SPECIFIED, THE FULLY EXECUTED PURCHASE ORDER WILL BE CONSIDERED NOTICE TO PROCEED.</p>						

RECEIVED
 2009 APR 28 PM 12:00
 WV PURCHASING
 DIVISION

SEE REVERSE SIDE FOR TERMS AND CONDITIONS

SIGNATURE: *[Signature]* TELEPHONE: (805) 963-3016 DATE: 4/24/09

TITLE: Estimator FEIN: 77-0301570 ADDRESS CHANGES TO BE NOTED ABOVE

WHEN RESPONDING TO RFQ, INSERT NAME AND ADDRESS IN SPACE ABOVE LABELED 'VENDOR'

**GENERAL TERMS & CONDITIONS
REQUEST FOR QUOTATION (RFQ) AND REQUEST FOR PROPOSAL (RFP)**

1. Awards will be made in the best interest of the State of West Virginia.
2. The State may accept or reject in part, or in whole, any bid.
3. All quotations are governed by the *West Virginia Code* and the *Legislative Rules* of the Purchasing Division.
4. Prior to any award, the apparent successful vendor must be properly registered with the Purchasing Division and have paid the required \$125 fee.
5. All services performed or goods delivered under State Purchase Order/Contracts are to be continued for the term of the Purchase Order/Contracts, contingent upon funds being appropriated by the Legislature or otherwise being made available. In the event funds are not appropriated or otherwise available for these services or goods, this Purchase Order/Contract becomes void and of no effect after June 30.
6. Payment may only be made after the delivery and acceptance of goods or services.
7. Interest may be paid for late payment in accordance with the *West Virginia Code*.
8. Vendor preference will be granted upon written request in accordance with the *West Virginia Code*.
9. The State of West Virginia is exempt from federal and state taxes and will not pay or reimburse such taxes.
10. The Director of Purchasing may cancel any Purchase Order/Contract upon 30 days written notice to the seller.
11. The laws of the State of West Virginia and the *Legislative Rules* of the Purchasing Division shall govern all rights and duties under the Contract, including without limitation the validity of this Purchase Order/Contract.
12. Any reference to automatic renewal is hereby deleted. The Contract may be renewed only upon mutual written agreement of the parties.
13. **BANKRUPTCY:** In the event the vendor/contractor files for bankruptcy protection, this Contract may be deemed null and void, and terminated without further order.
14. **HIPAA BUSINESS ASSOCIATE ADDENDUM:** The West Virginia State Government HIPAA Business Associate Addendum (BAA), approved by the Attorney General, and available online at the Purchasing Division's web site (<http://www.state.wv.us/admin/purchase/vrc/hipaa.htm>) is hereby made part of the agreement. Provided that, the Agency meets the definition of a Cover Entity (45 CFR §160.103) and will be disclosing Protected Health Information (45 CFR §160.103) to the vendor.
15. **WEST VIRGINIA ALCOHOL & DRUG-FREE WORKPLACE ACT:** If this Contract constitutes a public improvement construction contract as set forth in Article 1D, Chapter 21 of the West Virginia Code ("The West Virginia Alcohol and Drug-Free Workplace Act"), then the following language shall hereby become part of this Contract: "The contractor and its subcontractors shall implement and maintain a written drug-free workplace policy in compliance with the West Virginia Alcohol and Drug-Free Workplace Act, as set forth in Article 1D, Chapter 21 of the West Virginia Code. The contractor and its subcontractors shall provide a sworn statement in writing, under the penalties of perjury, that they maintain a valid drug-free work place policy in compliance with the West Virginia and Drug-Free Workplace Act. It is understood and agreed that this Contract shall be cancelled by the awarding authority if the Contractor: 1) Fails to implement its drug-free workplace policy; 2) Fails to provide information regarding implementation of the contractor's drug-free workplace policy at the request of the public authority; or 3) Provides to the public authority false information regarding the contractor's drug-free workplace policy."

INSTRUCTIONS TO BIDDERS

1. Use the quotation forms provided by the Purchasing Division.
2. **SPECIFICATIONS:** Items offered must be in compliance with the specifications. Any deviation from the specifications must be clearly indicated by the bidder. Alternates offered by the bidder as **EQUAL** to the specifications must be clearly defined. A bidder offering an alternate should attach complete specifications and literature to the bid. The Purchasing Division may waive minor deviations to specifications.
3. Complete all sections of the quotation form.
4. Unit prices shall prevail in case of discrepancy.
5. All quotations are considered F.O.B. destination unless alternate shipping terms are clearly identified in the quotation.
6. **BID SUBMISSION:** All quotations must be delivered by the bidder to the office listed below prior to the date and time of the bid opening. Failure of the bidder to deliver the quotations on time will result in bid disqualifications: Department of Administration, Purchasing Division, 2019 Washington Street East, P.O. Box 50130, Charleston, WV 25305-0130.



State of West Virginia
 Department of Administration
 Purchasing Division
 2019 Washington Street East
 Post Office Box 50130
 Charleston, WV 25305-0130

Request for Quotation

RFQ NUMBER
 MOC26997

PAGE
 2

ADDRESS CORRESPONDENCE TO ATTENTION OF
 JOHN ABBOTT
 304-558-2544

VENDOR

RFQ COPY
 TYPE NAME/ADDRESS HERE
Kamran & Company, Inc.
 411 East Montecito St.
 Santa Barbara, CA 93101
 (805) 963-3016 Fax (805) 962-5915

SHIP TO

DIVISION OF CORRECTIONS
 MOUNT OLIVE CORRECTIONAL
 CENTER
 ONE MOUNTAINSIDE WAY
 MT. OLIVE, WV
 25185 304-442-7216

DATE PRINTED	TERMS OF SALE	SHIP VIA	FOB	FREIGHT TERMS		
04/17/2009	Net 30		Destination			
BID OPENING DATE: 04/28/2009		BID OPENING TIME: 01:30PM				
LINE	QUANTITY	UOP	CAT NO	ITEM NUMBER	UNIT PRICE	AMOUNT
<p>CANCELLATION: THE DIRECTOR OF PURCHASING RESERVES THE RIGHT TO CANCEL THIS CONTRACT IMMEDIATELY UPON WRITTEN NOTICE TO THE VENDOR IF THE MATERIALS OR WORKMANSHIP SUPPLIED ARE OF AN INFERIOR QUALITY OR DO NOT CONFORM WITH THE SPECIFICATIONS OF THE BID AND CONTRACT HERE IN.</p> <p>WAGE RATES: THE CONTRACTOR OR SUBCONTRACTOR SHALL PAY THE HIGHER OF THE U.S. DEPARTMENT OF LABOR MINIMUM WAGE RATES AS ESTABLISHED FOR FAYETTE COUNTY, PURSUANT TO WEST VIRGINIA CODE 21-5A, ET, SEQ. (PREVAILING WAGE RATES APPLY TO THIS PROJECT)</p> <p>ARBITRATION: ANY REFERENCES MADE TO ARBITRATION OR INTEREST FOR PAYMENTS DUE (EXCEPT FOR ANY INTEREST REQUIRED BY STATE LAW) CONTAINED IN THIS CONTRACT OR IN ANY AMERICAN INSTITUTE OF ARCHITECTS DOCUMENTS PERTAINING TO THIS CONTRACT ARE HEREBY DELETED.</p> <p>WORKERS' COMPENSATION: VENDOR IS REQUIRED TO PROVIDE A CERTIFICATE FROM WORKERS' COMPENSATION IF SUCCESSFUL.</p> <p>ALL OF THE ITEMS CHECKED BELOW WILL BE A REQUIREMENT OF THIS CONTRACT:</p> <p>(XX) INSURANCE: SUCCESSFUL VENDOR SHALL FURNISH PROOF OF COMMERCIAL GENERAL LIABILITY INSURANCE PRIOR TO ISSUANCE OF CONTRACT. UNLESS OTHERWISE SPECIFIED IN THE BID DOCUMENTS, THE MINIMUM AMOUNT OF INSURANCE COVERAGE REQUIRED IS \$250,000.</p> <p>() BUILDERS RISK INSURANCE: SUCCESSFUL VENDOR SHALL FURNISH PROOF OF BUILDERS RISK - ALL RISK INSURANCE IN AN AMOUNT EQUAL TO 100% OF THE AMOUNT OF THE CONTRACT.</p>						
SEE REVERSE SIDE FOR TERMS AND CONDITIONS						
SIGNATURE: <i>[Signature]</i>		TELEPHONE: (805) 963-3016		DATE: 4/23/09		
TITLE: estimator		FAX: 77-0301570		ADDRESS CHANGES TO BE NOTED ABOVE		

WHEN RESPONDING TO RFQ, INSERT NAME AND ADDRESS IN SPACE ABOVE LABELED 'VENDOR'



State of West Virginia
 Department of Administration
 Purchasing Division
 2019 Washington Street East
 Post Office Box 50130
 Charleston, WV 25305-0130

Request for Quotation

RFQ NUMBER
 MOC26997

PAGE
 3

ADDRESS CORRESPONDENCE TO ATTENTION OF
 JOHN ABBOTT
 304-558-2544

VENDOR

RFQ COPY
 TYPE NAME/ADDRESS HERE
 Kamran & Company, Inc.
 411 East Montecito St.
 Santa Barbara, CA 93101
 (805) 963-3016 Fax (805) 962-5915

SHIP TO

DIVISION OF CORRECTIONS
 MOUNT OLIVE CORRECTIONAL
 CENTER
 ONE MOUNTAINSIDE WAY
 MT. OLIVE, WV
 25185 304-442-7216

DATE PRINTED	TERMS OF SALE	SHIP VIA	F.O.B.	FREIGHT TERMS
04/17/2009	Net 30			

BID OPENING DATE: 04/28/2009 BID OPENING TIME: 01:30PM

LINE	QUANTITY	UOP	CAT. NO.	ITEM NUMBER	UNIT PRICE	AMOUNT
<p>(XX) BONDS: FIVE PERCENT (5%) OF THE TOTAL AMOUNT OF THE BID PAYABLE TO THE STATE OF WEST VIRGINIA, SHALL BE SUBMITTED WITH EACH BID AS A BID BOND. THE SUCCESSFUL BIDDER SHALL ALSO FURNISH A PERFORMANCE BOND AND LABOR/MATERIAL BOND FOR 100% OF THE AMOUNT OF THE CONTRACT. BONDS MAY BE PROVIDED IN THE FORM OF A CERTIFIED CHECK IRREVOCABLE LETTER OF CREDIT, OR BOND FURNISHED BY A SOLVENT SURETY COMPANY AUTHORIZED TO DO BUSINESS IN THE STATE OF WEST VIRGINIA. A LETTER OF CREDIT SUBMITTED IN LIEU OF A BOND WILL ONLY BE ALLOWED FOR PROJECTS UNDER \$100,000. PERSONAL OR BUSINESS CHECKS ARE NOT ACCEPCTABLE IN LIEU OF THE 5% BID BOND, PERFORMANCE BOND, OR LABOR AND MATERIAL BOND.</p> <p>() MAINTENANCE BOND: A TWO (2) YEAR MAINTENANCE BOND COVERING THE ROOFING SYSTEM WILL BE A REQUIREMENT OF THE SUCCESSFUL VENDOR.</p> <p>REV. 11/00</p> <p>EXHIBIT 7</p> <p>DOMESTIC ALUMINUM, GLASS & STEEL IN PUBLIC WORKS PROJECTS</p> <p>IN ACCORDANCE WITH WEST VIRGINIA CODE 5-19-1 ET., SEQ., EVERY CONTRACT FOR CONSTRUCTION, RECONSTRUCTION, ALTERATION, REPAIR, IMPROVEMENT OR MAINTENANCE OF PUBLIC WORKS, WHERE THE COST IS MORE THAN \$50,000 AND, IN THE CASE OF STEEL ONLY, WHERE THE COST OF STEEL IS MORE THAN \$50,000 OR WHERE MORE THAN 10,000 POUNDS OF STEEL ARE REQUIRED, THE STATE WILL ACCEPT ONLY ALUMINUM GLASS, OR STEEL PRODUCTS PRODUCED IN THE UNITED STATES. IN ADDITION, ITEMS OF MACHINERY OR EQUIPMENT PURCHASED FOR USE AT THE SITE OF PUBLIC WORKS SHALL BE MADE OF</p>						

SEE REVERSE SIDE FOR TERMS AND CONDITIONS

SIGNATURE: *[Signature]* TELEPHONE: (805) 963-3016 DATE: 4/23/09

TITLE: Estimator FEIN: 77-0301570 ADDRESS CHANGES TO BE NOTED ABOVE

WHEN RESPONDING TO RFQ, INSERT NAME AND ADDRESS IN SPACE ABOVE LABELED 'VENDOR'



State of West Virginia
 Department of Administration
 Purchasing Division
 2019 Washington Street East
 Post Office Box 50130
 Charleston, WV 25305-0130

Request for Quotation

RFQ NUMBER:
 MOC26997

PAGE:
 4

ADDRESS CORRESPONDENCE TO ATTENTION OF:
 JOHN ABBOTT
 304-558-2544

VENDOR

RFQ COPY
 TYPE NAME/ADDRESS HERE
Kamran & Company, Inc.
 411 East Montecito St.
 Santa Barbara, CA 93101
 (805) 963-3016 Fax (805) 962-5915

SHIP TO

DIVISION OF CORRECTIONS
 MOUNT OLIVE CORRECTIONAL
 CENTER
 ONE MOUNTAINSIDE WAY
 MT. OLIVE, WV
 25185 304-442-7216

DATE PRINTED 04/17/2009	TERMS OF SALE <i>Net 30</i>	SHIP VIA	F.O.B. <i>Delivered</i>	FREIGHT TERMS
----------------------------	--------------------------------	----------	----------------------------	---------------

BID OPENING DATE: 04/28/2009 BID OPENING TIME 01:30PM

LINE	QUANTITY	UOP	CAT NO	ITEM NUMBER	UNIT PRICE	AMOUNT
<p>DOMESTIC ALUMINUM, GLASS OR STEEL, UNLESS THE COST OF THE PRODUCT IS LESS THAN \$50,000 OR LESS THAN 10,000 POUNDS OF STEEL ARE USED IN PUBLIC WORKS PROJECTS.</p> <p>FOREIGN MADE ALUMINUM, GLASS OR STEEL PRODUCTS MAY BE ACCEPTED ONLY IF THE COST OF DOMESTIC PRODUCTS IS FOUND TO BE UNREASONABLE. SUCH COST IS UNREASONABLE IF IT IS 20% OR MORE HIGHER THAN THE BID PRICE FOR FOREIGN MADE PRODUCTS. IF THE DOMESTIC ALUMINUM, GLASS OR STEEL PRODUCTS TO BE SUPPLIED OR PRODUCED IN A "SUBSTANTIAL LABOR SURPLUS AREA", AS DEFINED BY THE UNITED STATES DEPARTMENT OF LABOR, FOREIGN PRODUCTS MAY BE SUPPLIED ONLY IF DOMESTIC PRODUCTS ARE 30% OR MORE HIGHER IN PRICE THAN THE FOREIGN MADE PRODUCTS.</p> <p>IF, PRIOR TO THE AWARD OF A CONTRACT UNDER THE ABOVE PROVISIONS, THE SPENDING OFFICER OF THE SPENDING UNIT DETERMINES THAT THERE EXISTS A BID FOR LIKE FOREIGN ALUMINUM, GLASS OR STEEL THAT IS REASONABLE AND LOWER THAN THE LOWEST BID DOMESTIC PRODUCTS, THE SPENDING OFFICE MAY REQUEST, IN WRITING, A REEVALUATION AND REDUCTION IN THE LOWEST BID FOR SUCH DOMESTIC PRODUCTS. ALL VENDORS MUST INDICATE IN THEIR BID IF THEY ARE SUPPLYING FOREIGN ALUMINUM, GLASS OR STEEL.</p> <p>REV. 3/88</p> <p>EXHIBIT 9</p> <p>NOTICE FOR ISSUANCE & ACKNOWLEDGEMENT OF CONSTRUCTION PROJECT ADDENDA</p> <p>THE ARCHITECT/ENGINEER AND/OR AGENCY SHALL BE REQUIRED TO ABIDE BY THE FOLLOWING SCHEDULE IN ISSUING CONSTRUCTION PROJECT ADDENDA FOR STATE AGENCIES:</p>						

SEE REVERSE SIDE FOR TERMS AND CONDITIONS

SIGNATURE <i>[Signature]</i>	TELEPHONE (805) 963-3016	DATE 4/23/09
TITLE <i>[Signature]</i>	FEN 77-0301510	ADDRESS CHANGES TO BE NOTED ABOVE

WHEN RESPONDING TO RFQ, INSERT NAME AND ADDRESS IN SPACE ABOVE LABELED 'VENDOR'



State of West Virginia
 Department of Administration
 Purchasing Division
 2019 Washington Street East
 Post Office Box 50130
 Charleston, WV 25305-0130

Request for Quotation

RFQ NUMBER
 MOC26997

PAGE
 5

ADDRESS CORRESPONDENCE TO ATTENTION OF
 JOHN ABBOTT
 304-558-2544

BIDDING

RFQ COPY
 TYPE NAME/ADDRESS HERE

Kamran & Company, Inc.
 411 East Montecito St.
 Santa Barbara, CA 93101
 (805) 963-3016 Fax (805) 962-5915

BIDDING

DIVISION OF CORRECTIONS
 MOUNT OLIVE CORRECTIONAL
 CENTER
 ONE MOUNTAINSIDE WAY
 MT. OLIVE, WV
 25185 304-442-7216

DATE PRINTED	TERMS OF SALE	SHIP VIA	F.O.B.	FREIGHT TERMS
04/17/2009				

BID OPENING DATE: 04/28/2009 BID OPENING TIME 01:30PM

LINE	QUANTITY	UOP	CAT NO	ITEM NUMBER	UNIT PRICE	AMOUNT
<p>(1) THE ARCHITECT/ENGINEER SHALL PREPARE THE ADDENDUM AND A LIST OF ALL PARTIES THAT HAVE PROCURED DRAWINGS AND SPECIFICATIONS FOR THE PROJECT. THE ADDENDUM AND LIST SHALL BE FORWARDED TO THE BUYER IN THE STATE PURCHASING DIVISION. THE ARCHITECT/ENGINEER SHALL ALSO SEND A COPY OF THE ADDENDUM TO THE STATE AGENCY FOR WHICH THE CONTRACT IS ISSUED.</p> <p>(2) THE BUYER SHALL SEND THE ADDENDUM TO ALL INTERESTED PARTIES AND, IF NECESSARY, EXTEND THE BID OPENING DATE. ANY ADDENDUM SHOULD BE RECEIVED BY THE BUYER WITHIN FOURTEEN (14) DAYS PRIOR TO THE BID OPENING DATE.</p> <p>(3) ALL ADDENDA SHOULD BE FORMALLY ACKNOWLEDGED BY ALL BIDDERS AND SUBMITTED TO THE STATE PURCHASING DIVISION. THE SAME RULES AND REGULATIONS THAT APPLY TO THE ORIGINAL BIDDING DOCUMENT SHALL ALSO APPLY TO AN ADDENDUM DOCUMENT. THE ONLY EXCEPTION MAY BE FOR AN ADDENDUM THAT IS ISSUED FOR THE SOLE PURPOSE OF CHANGING A BID OPENING TIME AND/OR DATE.</p> <p>REV. 11/96</p> <p>EXHIBIT 10</p> <p>ADDENDUM ACKNOWLEDGEMENT</p> <p>I HEREBY ACKNOWLEDGE RECEIPT OF THE FOLLOWING CHECKED ADDENDUM(S) AND HAVE MADE THE NECESSARY REVISIONS TO MY PROPOSAL, PLANS AND/OR SPECIFICATION, ETC.</p> <p>ADDENDUM NOS :</p>						

SEE REVERSE SIDE FOR TERMS AND CONDITIONS

SIGNATURE <i>Eshmaev</i>	TELEPHONE (805) 963-3016	DATE 4/23/09
TITLE <i>Eshmaev</i>	FEIN 77-0301570	ADDRESS CHANGES TO BE NOTED ABOVE

WHEN RESPONDING TO RFQ, INSERT NAME AND ADDRESS IN SPACE ABOVE LABELED 'VENDOR'



State of West Virginia
 Department of Administration
 Purchasing Division
 2019 Washington Street East
 Post Office Box 50130
 Charleston, WV 25305-0130

Request for Quotation

RFQ NUMBER
 MOC26997

PAGE
 6

ADDRESS CORRESPONDENCE TO ATTENTION OF:
 JOHN ABBOTT
 304-558-2544

VENDOR

RFQ COPY
 TYPE NAME/ADDRESS HERE

Kamran & Company, Inc.
 411 East Montecito St.
 Santa Barbara, CA 93101
 (805) 963-3016 Fax (805) 962-5915

SHIP TO

DIVISION OF CORRECTIONS
 MOUNT OLIVE CORRECTIONAL
 CENTER
 ONE MOUNTAINSIDE WAY
 MT. OLIVE, WV
 25185 304-442-7216

DATE PRINTED 04/17/2009	TERMS OF SALE Net 30	SHIP VIA	F.O.B. Delivered	FREIGHT TERMS
----------------------------	-------------------------	----------	---------------------	---------------

BID OPENING DATE: 04/28/2009 BID OPENING TIME 01:30PM

LINE	QUANTITY	UOP	CAT. NO.	ITEM NUMBER	UNIT PRICE	AMOUNT
NO. 1		✓				
NO. 2						
NO. 3						
NO. 4						
NO. 5						

I UNDERSTAND THAT FAILURE TO CONFIRM THE RECEIPT OF TH ADDENDUM(S) MAY BE CAUSE FOR REJECTION OF THE BIDS.

VENDOR MUST CLEARLY UNDERSTAND THAT ANY VERBAL REPRESENTATION MADE OR ASSUMED TO BE MADE DURING ANY ORAL DISCUSSION HELD BETWEEN VENDOR'S REPRESENTATIVES AND ANY STATE PERSONNEL IS NOT BINDING. ONLY THE INFORMATION ISSUED IN WRITING AND ADDED TO THE SPECIFICATIONS BY AN OFFICIAL ADDENDUM IS BINDING.

Clayton PriceSIGNATURE
Kamran & Co., Inc.COMPANY
4/24/09DATE

REV. 11/96

APPLICABLE LAW

THE WEST VIRGINIA STATE CODE, PURCHASING DIVISION RULES AND REGULATIONS, AND THE INFORMATION PROVIDED IN THE "REQUEST FOR QUOTATION" ISSUED BY THE PURCHASING

SEE REVERSE SIDE FOR TERMS AND CONDITIONS

SIGNATURE <i>Clayton Price</i>	PHONE 963-3016	DATE 4/23/09
TITLE Estimator	FEIN 77-0301570	ADDRESS CHANGES TO BE NOTED ABOVE

WHEN RESPONDING TO RFQ, INSERT NAME AND ADDRESS IN SPACE ABOVE LABELED 'VENDOR'



State of West Virginia
 Department of Administration
 Purchasing Division
 2019 Washington Street East
 Post Office Box 50130
 Charleston, WV 25305-0130

Request for Quotation

RFQ NUMBER:
MOC26997

PAGE:
7

ADDRESS CORRESPONDENCE TO ATTENTION OF:
**JOHN ABBOTT
 304-558-2544**

RFQ COPY
 TYPE NAME/ADDRESS HERE

VENDOR

**Kamran & Company, Inc.
 411 East Montecito St.
 Santa Barbara, CA 93101
 (805) 963-3016 Fax (805) 962-5915**

SUPPLIER

**DIVISION OF CORRECTIONS
 MOUNT OLIVE CORRECTIONAL
 CENTER
 ONE MOUNTAIN SIDE WAY
 MT. OLIVE, WV
 25185 304-442-7216**

DATE PRINTED	TERMS OF SALE	SHIP VIA	F.O.B.	FREIGHT TERMS
04/17/2009				

BID OPENING DATE: **04/28/2009** BID OPENING TIME: **01:30PM**

LINE	QUANTITY	UOP	CAT. NO.	ITEM NUMBER	UNIT PRICE	AMOUNT
DIVISION IS THE SOLE AUTHORITY GOVERNING THIS PROCUREMENT.						
***** THIS IS THE END OF RFQ MOC26997 ***** TOTAL:						\$65,700

SEE REVERSE SIDE FOR TERMS AND CONDITIONS

SIGNATURE: *[Signature]* TELEPHONE: **(805) 963-3016** DATE: **4/17/09**

TITLE: *[Signature]* FEIN: **77-0301570** ADDRESS CHANGES TO BE NOTED ABOVE

WHEN RESPONDING TO RFQ, INSERT NAME AND ADDRESS IN SPACE ABOVE LABELED 'VENDOR'



State of West Virginia
 Department of Administration
 Purchasing Division
 2019 Washington Street East
 Post Office Box 50130
 Charleston, WV 25305-0130

Request for Quotation

RFQ NUMBER
 MOC26997

PAGE
 1

ADDRESS CORRESPONDENCE TO ATTENTION OF:
 JOHN ABBOTT
 304-558-2544

VENDOR

RFQ COPY
 TYPE NAME/ADDRESS HERE

Kamran & Company, Inc.
 411 East Montecito St.
 Santa Barbara, CA 93101
 (805) 963-3016 Fax (805) 962-5915

SHIP TO

DIVISION OF CORRECTIONS
 MOUNT OLIVE CORRECTIONAL
 CENTER
 ONE MOUNTAINSIDE WAY
 MT. OLIVE, WV
 25185 304-442-7216

DATE PRINTED	TERMS OF SALE	SHIP VIA	FOB	FREIGHT TERMS
04/23/2009	Net 30		Delivered	

BID OPENING DATE: 05/05/2009 BID OPENING TIME: 01:30PM

LINE	QUANTITY	UOP	CAT NO	ITEM NUMBER	UNIT PRICE	AMOUNT
0001				165-85		
ADDENDUM #02						
<p>THIS ADDENDUM IS ISSUED TO CHANGE THE QUANTITY REQUIRED FOR THIS REQUEST FOR QUOTATION; AND TO EXTEND THE BID OPENING FROM 4/28/2009 TO 5/5/2009; 1:30 PM</p> <p>VENDORS SHALL QUOTE TWO (2) TILTING KETTLES AND ONE (1) DOUBLE STACK STEAMER, PER THE REVISED ATTACHED BID FORM.</p>						
						\$ 54,100.-

***** THIS IS THE END OF RFQ MOC26997 ***** TOTAL: \$ 54,100.-

SEE REVERSE SIDE FOR TERMS AND CONDITIONS

SIGNATURE: *[Signature]* TELEPHONE: 963-3016 DATE: 4/30/09

TITLE: *[Signature]* FEIN: 77-0301570 ADDRESS CHANGES TO BE NOTED ABOVE

WHEN RESPONDING TO RFQ, INSERT NAME AND ADDRESS IN SPACE ABOVE LABELED 'VENDOR'

**GENERAL TERMS & CONDITIONS
REQUEST FOR QUOTATION (RFQ) AND REQUEST FOR PROPOSAL (RFP)**

1. Awards will be made in the best interest of the State of West Virginia.
2. The State may accept or reject in part, or in whole, any bid.
3. All quotations are governed by the *West Virginia Code* and the *Legislative Rules* of the Purchasing Division.
4. Prior to any award, the apparent successful vendor must be properly registered with the Purchasing Division and have paid the required \$125 fee.
5. All services performed or goods delivered under State Purchase Order/Contracts are to be continued for the term of the Purchase Order/Contracts, contingent upon funds being appropriated by the Legislature or otherwise being made available. In the event funds are not appropriated or otherwise available for these services or goods, this Purchase Order/Contract becomes void and of no effect after June 30.
6. Payment may only be made after the delivery and acceptance of goods or services.
7. Interest may be paid for late payment in accordance with the *West Virginia Code*.
8. Vendor preference will be granted upon written request in accordance with the *West Virginia Code*.
9. The State of West Virginia is exempt from federal and state taxes and will not pay or reimburse such taxes.
10. The Director of Purchasing may cancel any Purchase Order/Contract upon 30 days written notice to the seller.
11. The laws of the State of West Virginia and the *Legislative Rules* of the Purchasing Division shall govern all rights and duties under the Contract, including without limitation the validity of this Purchase Order/Contract.
12. Any reference to automatic renewal is hereby deleted. The Contract may be renewed only upon mutual written agreement of the parties.
13. **BANKRUPTCY:** In the event the vendor/contractor files for bankruptcy protection, this Contract may be deemed null and void, and terminated without further order.
14. **HIPAA BUSINESS ASSOCIATE ADDENDUM:** The West Virginia State Government HIPAA Business Associate Addendum (BAA), approved by the Attorney General, and available online at the Purchasing Division's web site (<http://www.state.wv.us/admin/purchase/vrc/hipaa.htm>) is hereby made part of the agreement. Provided that, the Agency meets the definition of a Cover Entity (45 CFR §160.103) and will be disclosing Protected Health Information (45 CFR §160.103) to the vendor.
15. **WEST VIRGINIA ALCOHOL & DRUG-FREE WORKPLACE ACT:** If this Contract constitutes a public improvement construction contract as set forth in Article 1D, Chapter 21 of the West Virginia Code ("The West Virginia Alcohol and Drug-Free Workplace Act"), then the following language shall hereby become part of this Contract: "The contractor and its subcontractors shall implement and maintain a written drug-free workplace policy in compliance with the West Virginia Alcohol and Drug-Free Workplace Act, as set forth in Article 1D, Chapter 21 of the West Virginia Code. The contractor and its subcontractors shall provide a sworn statement in writing, under the penalties of perjury, that they maintain a valid drug-free work place policy in compliance with the West Virginia and Drug-Free Workplace Act. It is understood and agreed that this Contract shall be cancelled by the awarding authority if the Contractor: 1) Fails to implement its drug-free workplace policy; 2) Fails to provide information regarding implementation of the contractor's drug-free workplace policy at the request of the public authority; or 3) Provides to the public authority false information regarding the contractor's drug-free workplace policy."

INSTRUCTIONS TO BIDDERS

1. Use the quotation forms provided by the Purchasing Division.
2. **SPECIFICATIONS:** Items offered must be in compliance with the specifications. Any deviation from the specifications must be clearly indicated by the bidder. Alternates offered by the bidder as **EQUAL** to the specifications must be clearly defined. A bidder offering an alternate should attach complete specifications and literature to the bid. The Purchasing Division may waive minor deviations to specifications.
3. Complete all sections of the quotation form.
4. Unit prices shall prevail in case of discrepancy.
5. All quotations are considered F.O.B. destination unless alternate shipping terms are clearly identified in the quotation.
6. **BID SUBMISSION:** All quotations must be delivered by the bidder to the office listed below prior to the date and time of the bid opening. Failure of the bidder to deliver the quotations on time will result in bid disqualifications: Department of Administration, Purchasing Division, 2019 Washington Street East, P.O. Box 50130, Charleston, WV 25305-0130

MOC26997 - Commercial Kitchen Equipment - BID FORM		
Description	Order Qty.	Extended Price
Double Stack Convection Steamer	1	\$ 12,100.-
Tilting Kettle	2	\$ 42,000.-
Failure to use this form may result in disqualification		\$ 54,100.-
Bidder / Vendor Information:		
Name:	Kamran and Company, Inc.	
Address:	411 E. Montecito St. Santa Barbara, CA 93101	
Phone# :	(805) 963-3016 x125	
Email Address:	clawdia@kamran.com	

Revised 4/23/2009



State of West Virginia
 Department of Administration
 Purchasing Division
 2019 Washington Street East
 Post Office Box 50130
 Charleston, WV 25305-0130

Request for Quotation

RFQ NUMBER
 MOC26997

PAGE
 1

ADDRESS CORRESPONDENCE TO ATTENTION OF
 JOHN ABBOTT
 304-558-2544

VENDOR

RFQ COPY
 TYPE NAME/ADDRESS HERE
 Kamran & Company, Inc.
 411 East Montecito St.
 Santa Barbara, CA 93101
 (805) 963-3016 Fax (805) 962-5915

SHIP TO

DIVISION OF CORRECTIONS
 MOUNT OLIVE CORRECTIONAL
 CENTER
 ONE MOUNTAINSIDE WAY
 MT. OLIVE, WV
 25185 304-442-7216

DATE PRINTED	TERMS OF SALE	SHIP VIA	F.O.B.	FREIGHT TERMS
04/24/2009	Net 30		Delivered	

BID OPENING DATE: 05/05/2009 BID OPENING TIME: 01:30PM

LINE	QUANTITY	UOP	CAT NO	ITEM NUMBER	UNIT PRICE	AMOUNT
ADDENDUM #03						
THIS ADDENDUM IS ISSUED TO ADD THE DRUG FREE COMPLIANCE AFFIDAVIT, WHICH IS REQUIRED WITH THE BID. FAILURE TO RETURN THIS EXECUTED FORM WITH YOUR BID IS AUTOMATIC DISQUALIFICATION.						
ATTACHMENT: DRUG FREE COMPLIANCE AFFIDAVIT						
0001				165-85		
				STEAM COOKERS		
***** THIS IS THE END OF RFQ MOC26997 ***** TOTAL:						54,100

SEE REVERSE SIDE FOR TERMS AND CONDITIONS

SIGNATURE: *Charles Ples* TELEPHONE: (805) 963-3016 DATE: 4/30/09
 TITLE: *Estimate* FEIN: 77-0301570 ADDRESS CHANGES TO BE NOTED ABOVE

WHEN RESPONDING TO RFQ, INSERT NAME AND ADDRESS IN SPACE ABOVE LABELED 'VENDOR'

**GENERAL TERMS & CONDITIONS
REQUEST FOR QUOTATION (RFQ) AND REQUEST FOR PROPOSAL (RFP)**

1. Awards will be made in the best interest of the State of West Virginia.
2. The State may accept or reject in part, or in whole, any bid.
3. All quotations are governed by the *West Virginia Code* and the *Legislative Rules* of the Purchasing Division.
4. Prior to any award, the apparent successful vendor must be properly registered with the Purchasing Division and have paid the required \$125 fee.
5. All services performed or goods delivered under State Purchase Order/Contracts are to be continued for the term of the Purchase Order/Contracts, contingent upon funds being appropriated by the Legislature or otherwise being made available. In the event funds are not appropriated or otherwise available for these services or goods, this Purchase Order/Contract becomes void and of no effect after June 30.
6. Payment may only be made after the delivery and acceptance of goods or services.
7. Interest may be paid for late payment in accordance with the *West Virginia Code*.
8. Vendor preference will be granted upon written request in accordance with the *West Virginia Code*.
9. The State of West Virginia is exempt from federal and state taxes and will not pay or reimburse such taxes.
10. The Director of Purchasing may cancel any Purchase Order/Contract upon 30 days written notice to the seller.
11. The laws of the State of West Virginia and the *Legislative Rules* of the Purchasing Division shall govern all rights and duties under the Contract, including without limitation the validity of this Purchase Order/Contract.
12. Any reference to automatic renewal is hereby deleted. The Contract may be renewed only upon mutual written agreement of the parties.
13. **BANKRUPTCY:** In the event the vendor/contractor files for bankruptcy protection, this Contract may be deemed null and void, and terminated without further order.
14. **HIPAA BUSINESS ASSOCIATE ADDENDUM:** The West Virginia State Government HIPAA Business Associate Addendum (BAA), approved by the Attorney General, and available online at the Purchasing Division's web site (<http://www.state.wv.us/admin/purchase/vrc/hipaa.htm>) is hereby made part of the agreement. Provided that, the Agency meets the definition of a Cover Entity (45 CFR §160.103) and will be disclosing Protected Health Information (45 CFR §160.103) to the vendor.
15. **WEST VIRGINIA ALCOHOL & DRUG-FREE WORKPLACE ACT:** If this Contract constitutes a public improvement construction contract as set forth in Article 1D, Chapter 21 of the West Virginia Code ("The West Virginia Alcohol and Drug-Free Workplace Act"), then the following language shall hereby become part of this Contract: "The contractor and its subcontractors shall implement and maintain a written drug-free workplace policy in compliance with the West Virginia Alcohol and Drug-Free Workplace Act, as set forth in Article 1D, Chapter 21 of the West Virginia Code. The contractor and its subcontractors shall provide a sworn statement in writing, under the penalties of perjury, that they maintain a valid drug-free work place policy in compliance with the West Virginia and Drug-Free Workplace Act. It is understood and agreed that this Contract shall be cancelled by the awarding authority if the Contractor: 1) Fails to implement its drug-free workplace policy; 2) Fails to provide information regarding implementation of the contractor's drug-free workplace policy at the request of the public authority; or 3) Provides to the public authority false information regarding the contractor's drug-free workplace policy."

INSTRUCTIONS TO BIDDERS

1. Use the quotation forms provided by the Purchasing Division.
2. **SPECIFICATIONS:** Items offered must be in compliance with the specifications. Any deviation from the specifications must be clearly indicated by the bidder. Alternates offered by the bidder as **EQUAL** to the specifications must be clearly defined. A bidder offering an alternate should attach complete specifications and literature to the bid. The Purchasing Division may waive minor deviations to specifications.
3. Complete all sections of the quotation form.
4. Unit prices shall prevail in case of discrepancy.
5. All quotations are considered F.O.B. destination unless alternate shipping terms are clearly identified in the quotation.
6. **BID SUBMISSION:** All quotations must be delivered by the bidder to the office listed below prior to the date and time of the bid opening. Failure of the bidder to deliver the quotations on time will result in bid disqualifications: Department of Administration, Purchasing Division, 2019 Washington Street East, P.O. Box 50130, Charleston, WV 25305-0130



State of West Virginia
DRUG FREE WORKPLACE CONFORMANCE AFFIDAVIT
West Virginia Code §21-1D-5

STATE OF California
COUNTY OF Santa Barbara TO-WIT:

I, Claudia Ponce, after being first duly sworn, depose and state as follows:

1. I am an employee of Kamran & Co., Inc.; and,
(Company Name)
2. I do hereby attest that Kamran & Co., Inc.
(Company Name)

maintains a valid written drug free workplace policy and that such policy is in compliance with **West Virginia Code §21-1D-5**.

The above statements are sworn to under the penalty of perjury.

Kamran & Co., Inc.
(Company Name)

By: Claudia Ponce

Title: Estimator

Date: 4/30/09

Taken, subscribed and sworn to before me this _____ day of _____.

By Commission expires _____

(Seal)

(Notary Public)

THIS AFFIDAVIT MUST BE SUBMITTED WITH THE BID IN ORDER TO COMPLY WITH WV CODE PROVISIONS. FAILURE TO INCLUDE THE AFFIDAVIT WITH THE BID SHALL RESULT IN DISQUALIFICATION OF THE BID.

CALIFORNIA JURAT WITH AFFIANT STATEMENT

- See Attached Document (Notary to cross out lines 1-6 below)
- See Statement Below (Lines 1-5 to be completed only by document signer[s], *not* Notary)

1 _____
 2 _____
 3 _____
 4 _____
 5 _____
 6 _____

Signature of Document Signer No. 1 Signature of Document Signer No. 2 (if any)

State of California
 County of Santa Barbara

Subscribed and sworn to (or affirmed) before me on this
30 day of April, 2009, by
Date Month Year

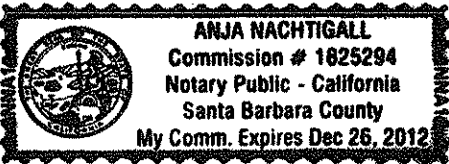

(1) Claudia Ponce
Name of Signer

proved to me on the basis of satisfactory evidence to be the person who appeared before me (.) (.)

(and

(2) _____
Name of Signer

proved to me on the basis of satisfactory evidence to be the person who appeared before me.)

Signature Anja Nachtigall
Signature of Notary Public

Place Notary Seal Above

OPTIONAL

Though the information below is not required by law, it may prove valuable to persons relying on the document and could prevent fraudulent removal and reattachment of this form to another document.

Further Description of Any Attached Document

Title or Type of Document: _____
 Document Date: _____ Number of Pages: _____
 Signer(s) Other Than Named Above: _____

RIGHT THUMBPRINT OF SIGNER #1
 Top of thumb here

RIGHT THUMBPRINT OF SIGNER #2
 Top of thumb here

CALIFORNIA ALL-PURPOSE ACKNOWLEDGMENT

State of California

County of Los Angeles

On April 23, 2009, before me, DONNA M. GREEN, Notary Public,
personally appeared MARY SMITH,

who proved to me on the basis of satisfactory evidence to be the person(X) whose name(X) is/are subscribed to the within instrument and acknowledged to me that ~~he/she/they~~ executed the same in his/her/~~their~~ authorized capacity(ies), and that by his/her/~~their~~ signature(X) on the instrument the person(X), or the entity upon behalf of which the person(X) acted, executed the instrument.



Place Notary Seal Above

I certify under PENALTY OF PERJURY under the laws of the State of California that the foregoing paragraph is true and correct.

WITNESS my hand and official seal.

Signature Donna M. Green
Signature of Notary Public

OPTIONAL

Though the data below is not required by law, it may prove valuable to persons relying on the document and could prevent fraudulent reattachment of this form.

CAPACITY CLAIMED BY SIGNER

DESCRIPTION OF ATTACHED DOCUMENT

- INDIVIDUAL
- CORPORATE OFFICER

- PARTNER(S)
- ATTORNEY-IN-FACT
- TRUSTEE(S)
- GUARDIAN/CONSERVATOR
- LIMITED

OTHER:

SIGNER IS REPRESENTING:
NAME OF PERSON(S) OR ENTITY(IES)

**Power of Attorney
FIDELITY AND DEPOSIT COMPANY OF MARYLAND**

KNOW ALL MEN BY THESE PRESENTS: That the FIDELITY AND DEPOSIT COMPANY OF MARYLAND, a corporation of the State of Maryland, by M. P. HAMMOND, Vice President, and ERIC D. BARNES, Assistant Secretary, in pursuance of authority granted by Article VI, Section 2, of the By-Laws of said Company, which are set forth on the reverse side hereof and are hereby certified to be in full force and effect on the date hereof, does hereby nominate, constitute and appoint **Mary SMITH, of Pasadena, California**, its true and lawful agent and Attorney-in-Fact, to make, execute, seal and deliver, for, and on its behalf as surety, and as its act and deed, ~~any and all bonds and undertakings~~, and the execution of such bonds or undertakings in pursuance of these presents, shall be as binding upon said Company, as fully and amply, to all intents and purposes, as if they had been duly executed and acknowledged by the regularly elected officers of the Company at its office in Baltimore, Md., in their own proper persons. This power of attorney revokes that issued on behalf of Mary SMITH, dated March 27, 1996.

The said Assistant Secretary does hereby certify that the extract set forth on the reverse side hereof is a true copy of Article VI, Section 2, of the By-Laws of said Company, and is now in force.

IN WITNESS WHEREOF, the said Vice-President and Assistant Secretary have hereunto subscribed their names and affixed the Corporate Seal of the said FIDELITY AND DEPOSIT COMPANY OF MARYLAND, this 31st day of July, A.D. 2007.

ATTEST:

FIDELITY AND DEPOSIT COMPANY OF MARYLAND

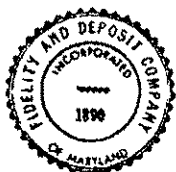

Eric D. Barnes

Eric D. Barnes Assistant Secretary

M. P. Hammond

By: *M. P. Hammond* Vice President

State of Maryland }
City of Baltimore } ss:

On this 31st day of July, A.D. 2007, before the subscriber, a Notary Public of the State of Maryland, duly commissioned and qualified, came M. P. HAMMOND, Vice President, and ERIC D. BARNES, Assistant Secretary of the FIDELITY AND DEPOSIT COMPANY OF MARYLAND, to me personally known to be the individuals and officers described in and who executed the preceding instrument, and they each acknowledged the execution of the same, and being by me duly sworn, severally and each for himself depose and saith, that they are the said officers of the Company aforesaid, and that the seal affixed to the preceding instrument is the Corporate Seal of said Company, and that the said Corporate Seal and their signatures as such officers were duly affixed and subscribed to the said instrument by the authority and direction of the said Corporation.

IN TESTIMONY WHEREOF, I have hereunto set my hand and affixed my Official Seal the day and year first above written.



Constance A. Dunn

Constance A. Dunn Notary Public
My Commission Expires: July 14, 2011

EXTRACT FROM BY-LAWS OF FIDELITY AND DEPOSIT COMPANY OF MARYLAND

“Article VI, Section 2. The Chairman of the Board, or the President, or any Executive Vice-President, or any of the Senior Vice-Presidents or Vice-Presidents specially authorized so to do by the Board of Directors or by the Executive Committee, shall have power, by and with the concurrence of the Secretary or any one of the Assistant Secretaries, to appoint Resident Vice-Presidents, Assistant Vice-Presidents and Attorneys-in-Fact as the business of the Company may require, or to authorize any person or persons to execute on behalf of the Company any bonds, undertakings, recognizances, stipulations, policies, contracts, agreements, deeds, and releases and assignments of judgements, decrees, mortgages and instruments in the nature of mortgages,...and to affix the seal of the Company thereto.”

CERTIFICATE

I, the undersigned, Assistant Secretary of the FIDELITY AND DEPOSIT COMPANY OF MARYLAND, do hereby certify that the foregoing Power of Attorney is still in full force and effect on the date of this certificate; and I do further certify that the Vice-President who executed the said Power of Attorney was one of the additional Vice-Presidents specially authorized by the Board of Directors to appoint any Attorney-in-Fact as provided in Article VI, Section 2, of the By-Laws of the FIDELITY AND DEPOSIT COMPANY OF MARYLAND.

This Power of Attorney and Certificate may be signed by facsimile under and by authority of the following resolution of the Board of Directors of the FIDELITY AND DEPOSIT COMPANY OF MARYLAND at a meeting duly called and held on the 10th day of May, 1990.

RESOLVED: "That the facsimile or mechanically reproduced seal of the company and facsimile or mechanically reproduced signature of any Vice-President, Secretary, or Assistant Secretary of the Company, whether made heretofore or hereafter, wherever appearing upon a certified copy of any power of attorney issued by the Company, shall be valid and binding upon the Company with the same force and effect as though manually affixed."

IN TESTIMONY WHEREOF, I have hereunto subscribed my name and affixed the corporate seal of the said Company,

this 23rd day of April, 2009.

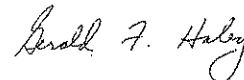

Assistant Secretary

CALIFORNIA ALL-PURPOSE ACKNOWLEDGMENT

State of California

County of Santa Barbara



On 4/24/09 before me, Anja Nachtigall, Notary Public
Date Here Insert Name and Title of the Officer

personally appeared Firouzeh Amiri
Name(s) of Signer(s)

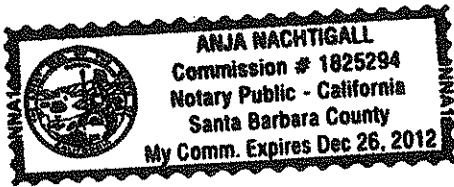

who proved to me on the basis of satisfactory evidence to be the person(s) whose name(s) is/are subscribed to the within instrument and acknowledged to me that he/she/they executed the same in his/her/their authorized capacity(ies), and that by his/her/their signature(s) on the instrument the person(s), or the entity upon behalf of which the person(s) acted, executed the instrument.

I certify under PENALTY OF PERJURY under the laws of the State of California that the foregoing paragraph is true and correct.

WITNESS my hand and official seal.

Place Notary Seal Above

Signature Anja Nachtigall
Signature of Notary Public

OPTIONAL

Though the information below is not required by law, it may prove valuable to persons relying on the document and could prevent fraudulent removal and reattachment of this form to another document.

Description of Attached Document

Title or Type of Document: _____

Document Date: _____ Number of Pages: _____

Signer(s) Other Than Named Above: _____

Capacity(ies) Claimed by Signer(s)

Signer's Name: _____

- Individual
- Corporate Officer — Title(s): _____
- Partner — Limited General
- Attorney in Fact
- Trustee
- Guardian or Conservator
- Other: _____

Signer Is Representing: _____

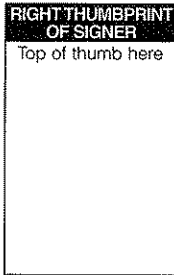

Signer's Name: _____

- Individual
- Corporate Officer — Title(s): _____
- Partner — Limited General
- Attorney in Fact
- Trustee
- Guardian or Conservator
- Other: _____

Signer Is Representing: _____

