



State of West Virginia
 Department of Administration
 Purchasing Division
 2019 Washington Street East
 Post Office Box 50130
 Charleston, WV 25305-0130

Request for Quotation

RFO NUMBER
MOC26997

PAGE
1

ADDRESS CORRESPONDENCE TO ATTENTION OF
**JOHN ABBOTT
 304-558-2544**

RFQ COPY
 TYPE NAME/ADDRESS HERE

**Douglas Equipment
 301 North Street
 Bluefield, WV 24701
 (304) 327-0149 1-(800) 962-8618**

**DIVISION OF CORRECTIONS
 MOUNT OLIVE CORRECTIONAL
 CENTER
 ONE MOUNTAINSIDE WAY
 MT. OLIVE, WV
 25185 304-442-7216**

DATE PRINTED	TERMS OF SALE	SHIP VIA	F.O.B.	FREIGHT TERMS
04/09/2009				

BID OPENING DATE: **04/28/2009** BID OPENING TIME **01:30PM**

LINE	QUANTITY	UOP	CAT. NO.	ITEM NUMBER	UNIT PRICE	AMOUNT
0001	2	EA		165-85		
<p>STEAM COOKERS</p> <p><i>See Addendum # 2</i></p> <p>CONTRACT TO PROVIDE COMMERCIAL KITCHEN STEAMERS AND TILTING KETTLES, INCLUDING INSTALLATION, FOR THE MT. OLIVE CORRECTIONAL CENTER, MT. OLIVE, WV, PER THE SPECIFICATIONS.</p> <p>ALL REQUIREMENTS LISTED IN THE ATTACHED SPECIFICATIONS ARE TO BE BID; BRAND AND MODEL NUMBERS LISTED ARE THE MINIMUM STANDARD OF QUALITY ACCEPTABLE - BIDDERS SHALL INCLUDE AN EQUAL OR SUPERIOR PRODUCT AS LISTED.</p> <p>INSTALLATION, SET-UP, & TESTING IS REQUIRED.</p> <p>REMOVAL OF THE OLD EQUIPMENT IS THE RESPONSIBILITY OF THE SUCCESSFUL VENDOR. THE OLD EQUIPMENT SHALL BE PLACED AT A DESIGNATED STORAGE AREA WITHIN THE FACILITY.</p> <p>NOTICE</p> <p>A SIGNED BID MUST BE SUBMITTED TO:</p> <p>DEPARTMENT OF ADMINISTRATION PURCHASING DIVISION BUILDING 15 2019 WASHINGTON STREET, EAST CHARLESTON, WV 25305-0130</p>						

RECEIVED

2009 MAY -1 P 1:04

PURCHASING DIVISION
 STATE OF WV

SEE REVERSE SIDE FOR TERMS AND CONDITIONS

SIGNATURE <i>John Mgr</i>	TELEPHONE (800) 962-8618	DATE 04-22-09
TITLE Mgr	FEIN 55-0585890	ADDRESS CHANGES TO BE NOTED ABOVE

WHEN RESPONDING TO RFQ, INSERT NAME AND ADDRESS IN SPACE ABOVE LABELED 'VENDOR'



State of West Virginia
 Department of Administration
 Purchasing Division
 2019 Washington Street East
 Post Office Box 50130
 Charleston, WV 25305-0130

Request for Quotation

RFQ NUMBER:
MOC26997

PAGE:
2

ADDRESS CORRESPONDENCE TO ATTENTION OF:
**JOHN ABBOTT
 304-558-2544**

RFQ COPY
 TYPE NAME/ADDRESS HERE

**Douglas Equipment
 301 North Street
 Bluefield, WV 24701
 (304) 327-0149 1-(800) 962-8618**

**DIVISION OF CORRECTIONS
 MOUNT OLIVE CORRECTIONAL
 CENTER
 ONE MOUNTAINSIDE WAY
 MT. OLIVE, WV
 25185 304-442-7216**

DATE PRINTED 04/09/2009	TERMS OF SALE	SHIP VIA	F.O.B.	FREIGHT TERMS
BID OPENING DATE: 04/28/2009		BID OPENING TIME 01:30PM		

LINE	QUANTITY	UQP	CAT NO.	ITEM NUMBER	UNIT PRICE	AMOUNT
<p>THE BID SHOULD CONTAIN THIS INFORMATION ON THE FACE OF THE ENVELOPE OR THE BID MAY NOT BE CONSIDERED:</p> <p>SEALED BID</p> <p>BUYER: JOHN ABBOTT-----</p> <p>RFQ. NO.: MOC26997-----</p> <p>BID OPENING DATE: 4/28/2009-----</p> <p>BID OPENING TIME: 1:30 PM-----</p> <p>PLEASE PROVIDE A FAX NUMBER IN CASE IT IS NECESSARY TO CONTACT YOU REGARDING YOUR BID: 304-325-3848</p> <p>CONTACT PERSON (PLEASE PRINT CLEARLY): BEN DONEVANT, III</p> <p>***** THIS IS THE END OF RFQ MOC26997 ***** TOTAL: \$ 51,278.00</p>						

SEE REVERSE SIDE FOR TERMS AND CONDITIONS

SIGNATURE: *Ben Donevant III* TELEPHONE: **(800) 962-8618** DATE: **04-22-09**

TITLE: *Ben Donevant* FEIN: **55-0585890** ADDRESS CHANGES TO BE NOTED ABOVE

WHEN RESPONDING TO RFQ, INSERT NAME AND ADDRESS IN SPACE ABOVE LABELED 'VENDOR'



State of West Virginia
 Department of Administration
 Purchasing Division
 2019 Washington Street East
 Post Office Box 50130
 Charleston, WV 25305-0130

Request for Quotation

RFQ NUMBER
 MOC26997

PAGE
 3

ADDRESS CORRESPONDENCE TO ATTENTION OF
 JOHN ABBOTT
 304-558-2544

RFQ COPY
 TYPE NAME/ADDRESS HERE

Douglas Equipment
 301 North Street
 Bluefield, WV 24701
 (304) 327-0149 1-(800) 962-8618

DIVISION OF CORRECTIONS
 MOUNT OLIVE CORRECTIONAL
 CENTER
 ONE MOUNTAINSIDE WAY
 MT. OLIVE, WV
 25185 304-442-7216

DATE PRINTED	TERMS OF SALE	SHIP VIA	F.O.B.	FREIGHT TERMS
04/17/2009				

BID OPENING DATE: 04/28/2009 BID OPENING TIME: 01:30PM

LINE	QUANTITY	UOP	CAT NO	ITEM NUMBER	UNIT PRICE	AMOUNT
<p>(XX) BONDS: FIVE PERCENT (5%) OF THE TOTAL AMOUNT OF THE BID PAYABLE TO THE STATE OF WEST VIRGINIA, SHALL BE SUBMITTED WITH EACH BID AS A BID BOND. THE SUCCESSFUL BIDDER SHALL ALSO FURNISH A PERFORMANCE BOND AND LABOR/MATERIAL BOND FOR 100% OF THE AMOUNT OF THE CONTRACT. BONDS MAY BE PROVIDED IN THE FORM OF A CERTIFIED CHECK IRREVOCABLE LETTER OF CREDIT, OR BOND FURNISHED BY A SOLVENT SURETY COMPANY AUTHORIZED TO DO BUSINESS IN THE STATE OF WEST VIRGINIA. A LETTER OF CREDIT SUBMITTED IN LIEU OF A BOND WILL ONLY BE ALLOWED FOR PROJECTS UNDER \$100,000. PERSONAL OR BUSINESS CHECKS ARE NOT ACCEPCTABLE IN LIEU OF THE 5% BID BOND, PERFORMANCE BOND, OR LABOR AND MATERIAL BOND.</p> <p>() MAINTENANCE BOND: A TWO (2) YEAR MAINTENANCE BOND COVERING THE ROOFING SYSTEM WILL BE A REQUIREMENT OF THE SUCCESSFUL VENDOR.</p> <p>REV. 11/00</p> <p>EXHIBIT 7</p> <p>DOMESTIC ALUMINUM, GLASS & STEEL IN PUBLIC WORKS PROJECTS</p> <p>IN ACCORDANCE WITH WEST VIRGINIA CODE 5-19-1 ET., SEQ., EVERY CONTRACT FOR CONSTRUCTION, RECONSTRUCTION, ALTERATION, REPAIR, IMPROVEMENT OR MAINTENANCE OF PUBLIC WORKS, WHERE THE COST IS MORE THAN \$50,000 AND, IN THE CASE OF STEEL ONLY, WHERE THE COST OF STEEL IS MORE THAN \$50,000 OR WHERE MORE THAN 10,000 POUNDS OF STEEL ARE REQUIRED, THE STATE WILL ACCEPT ONLY ALUMINUM GLASS, OR STEEL PRODUCTS PRODUCED IN THE UNITED STATES. IN ADDITION, ITEMS OF MACHINERY OR EQUIPMENT PURCHASED FOR USE AT THE SITE OF PUBLIC WORKS SHALL BE MADE OF</p>						

SIGNATURE: *[Signature]* TELEPHONE: 800 962 8618 DATE: 04-22-09
 TITLE: *[Signature]* FEIN: 55-0585790 ADDRESS CHANGES TO BE NOTED ABOVE

WHEN RESPONDING TO RFQ, INSERT NAME AND ADDRESS IN SPACE ABOVE LABELED 'VENDOR'

NEW PEOPLES BANK

www.newpeoplesbank.com

PO Box 1810 • Honaker, VA 24260 • Phone: 276.873.6288 • Fax: 276.873.6282

TO: State of West Virginia
Department of Administration, Purchasing Division
2019 Washington Street East – P O Box 50130
Charleston, WV 25305-0130

RE: Douglas Foodstores DBA: Douglas Equipment
301 North Street
Bluefield, WV 24701

AMOUNT: \$2,563.90 (Two Thousand, five-hundred and sixty-
three Dollars and 90/100)

**ISSUING
BANK:** New Peoples Bank, Inc.
514 Commerce Drive, P O Box 517
Bluefield, VA 24605

CREDIT #: MOC26997

**EFFECTIVE
DATE:** April 30, 2009

**EXPIRATION
DATE:** May 5, 2009

This Irrevocable Letter of Credit will expire at midnight on May 5, 2009.

Drafts when presented for negotiation must bear on its face the phrase “Drawn under Credit Number MOC26997” dated April 30, 2009, of New Peoples Bank, Inc. 514 Commerce Drive, Bluefield, VA 24605, and your written statement certifying that Douglas Foodstores DBA: Douglas Equipment failed to pay in accordance with their obligations.

This Letter of Credit must be presented during banking hours to New Peoples Bank, Inc. at the above address. For purposes hereof, “banking hours” shall mean 9:00 AM to 2:00 PM Monday through Friday, excluding bank holidays and other days on which banks in West Virginia/Virginia are authorized or required to close.

The Bank must be given a certified statement from the Beneficiary that the amount drafted upon is due from its customer.

Conveniently Serving You In

*Abingdon • Big Stone Gap • Bluefield • Bramwell • Bristol Commonwealth Ave. • Bristol Linden Square Dr. • Castlewood • Chilhowie
Cleveland • Clintwood • Davenport • Dungannon • Gate City • Grundy • Haysi • Honaker • Jonesborough • Jonesville • Kingsport
Lebanon • Norton • Pennington Gap • Pound • Pounding Mill • Princeton • Richlands • Tazewell • Weber City • Wise*

NEW PEOPLES BANK

www.newpeoplesbank.com

PO Box 1810 • Honaker, VA 24260 • Phone: 276.873.6288 • Fax: 276.873.6282

TO: STATE OF WEST VIRGINIA
DATE: April 30, 2009
Page – 2

Except as otherwise provided herein, this Letter of Credit is subject to the Uniform Customs and Practice for Documentary Credits, 1993 revision, International Chamber of Commerce Publication No. 500, and to the extent not inconsistent therewith, to the laws of the State of Virginia.

We hereby agree with the drawee, endorsers, and bona-fide holders of this credit that said bill will be duly honored on presentation, if presented to us at our office, above address, on or before the expiration date.

This credit expires at midnight – May 5, 2009.

NEW PEOPLES BANK, INC.

BY: Sharon V. Borich
Sharon V. Borich
Vice President

IP # 193213
Taken, subscribed, and sworn before me this 30th day of April, ²⁰⁰⁹~~2005~~.

Jane B. Carter
Notary Public

My Commission Expires:

12/31/09

Conveniently Serving You In

Abingdon • Big Stone Gap • Bluefield • Bramwell • Bristol Commonwealth Ave. • Bristol Linden Square Dr. • Castlewood • Chilhowie
Cleveland • Clintwood • Davenport • Dungannon • Gate City • Grundy • Haysi • Honaker • Jonesborough • Jonesville • Kingsport
Lebanon • Norton • Pennington Gap • Pound • Pounding Mill • Princeton • Richlands • Tazewell • Weber City • Wise



State of West Virginia
 Department of Administration
 Purchasing Division
 2019 Washington Street East
 Post Office Box 50130
 Charleston, WV 25305-0130

Request for Quotation

RFQ NUMBER
 MOC26997

PAGE
 4

ADDRESS CORRESPONDENCE TO ATTENTION OF
 JOHN ABBOTT
 304-558-2544

RFQ COPY
 TYPE NAME/ADDRESS HERE

Douglas Equipment
 301 North Street
 Bluefield, WV 24701
 (304) 327-0149 1-(800) 962-8613

DIVISION OF CORRECTIONS
 MOUNT OLIVE CORRECTIONAL
 CENTER
 ONE MOUNTAINSIDE WAY
 MT. OLIVE, WV
 25185 304-442-7216

DATE PRINTED 04/17/2009	TERMS OF SALE	SHIP VIA	F.O.B.	FREIGHT TERMS
----------------------------	---------------	----------	--------	---------------

BID OPENING DATE: 04/28/2009 BID OPENING TIME 01:30PM

LINE	QUANTITY	UOP	CAT NO.	ITEM NUMBER	UNIT PRICE	AMOUNT
<p>DOMESTIC ALUMINUM, GLASS OR STEEL, UNLESS THE COST OF THE PRODUCT IS LESS THAN \$50,000 OR LESS THAN 10,000 POUNDS OF STEEL ARE USED IN PUBLIC WORKS PROJECTS.</p> <p>FOREIGN MADE ALUMINUM, GLASS OR STEEL PRODUCTS MAY BE ACCEPTED ONLY IF THE COST OF DOMESTIC PRODUCTS IS FOUND TO BE UNREASONABLE. SUCH COST IS UNREASONABLE IF IT IS 20% OR MORE HIGHER THAN THE BID PRICE FOR FOREIGN MADE PRODUCTS. IF THE DOMESTIC ALUMINUM, GLASS OR STEEL PRODUCTS TO BE SUPPLIED OR PRODUCED IN A "SUBSTANTIAL LABOR SURPLUS AREA", AS DEFINED BY THE UNITED STATES DEPARTMENT OF LABOR, FOREIGN PRODUCTS MAY BE SUPPLIED ONLY IF DOMESTIC PRODUCTS ARE 30% OR MORE HIGHER IN PRICE THAN THE FOREIGN MADE PRODUCTS.</p> <p>IF, PRIOR TO THE AWARD OF A CONTRACT UNDER THE ABOVE PROVISIONS, THE SPENDING OFFICER OF THE SPENDING UNIT DETERMINES THAT THERE EXISTS A BID FOR LIKE FOREIGN ALUMINUM, GLASS OR STEEL THAT IS REASONABLE AND LOWER THAN THE LOWEST BID DOMESTIC PRODUCTS, THE SPENDING OFFICE MAY REQUEST, IN WRITING, A REEVALUATION AND REDUCTION IN THE LOWEST BID FOR SUCH DOMESTIC PRODUCTS. ALL VENDORS MUST INDICATE IN THEIR BID IF THEY ARE SUPPLYING FOREIGN ALUMINUM, GLASS OR STEEL.</p> <p>REV. 3/88</p> <p>EXHIBIT 9</p> <p>NOTICE FOR ISSUANCE & ACKNOWLEDGEMENT OF CONSTRUCTION PROJECT ADDENDA</p> <p>THE ARCHITECT/ENGINEER AND/OR AGENCY SHALL BE REQUIRED TO ABIDE BY THE FOLLOWING SCHEDULE IN ISSUING CONSTRUCTION PROJECT ADDENDA FOR STATE AGENCIES:</p>						
<p>SEE REVERSE SIDE FOR TERMS AND CONDITIONS.</p>						

*OUR ITEMS BEING PROVIDED
 COST LESS THAN \$50,000.00 EACH
 SO THIS PROVISION DOES NOT APPLY.
 JBB*

SIGNATURE *J.B. Bonavent II* TELEPHONE 800 962 8618 DATE 04-27-09
 TITLE *Asst Mgr* FEIN 55-0585890 ADDRESS CHANGES TO BE NOTED ABOVE

WHEN RESPONDING TO RFQ, INSERT NAME AND ADDRESS IN SPACE ABOVE LABELED 'VENDOR'



State of West Virginia
 Department of Administration
 Purchasing Division
 2019 Washington Street East
 Post Office Box 50130
 Charleston, WV 25305-0130

Request for Quotation

REQ NUMBER
 MOC26997

PAGE
 5

ADDRESS CORRESPONDENCE TO ATTENTION OF
 JOHN ABBOTT
 304-558-2544

VENDOR

RFQ COPY
 TYPE NAME/ADDRESS HERE

Douglas Equipment
 301 North Street
 Bluefield, WV 24701
 (304) 327-0149 1-(800) 962-8618

SHIP TO

DIVISION OF CORRECTIONS
 MOUNT OLIVE CORRECTIONAL
 CENTER
 ONE MOUNTAINSIDE WAY
 MT. OLIVE, WV
 25185 304-442-7216

DATE PRINTED	TERMS OF SALE	SHIP VIA	F.O.B.	FREIGHT TERMS
04/17/2009				

LINE	QUANTITY	UOP	CAT NO	ITEM NUMBER	UNIT PRICE	AMOUNT
<p>BID OPENING DATE: 04/28/2009</p> <p>BID OPENING TIME: 01:30PM</p> <p>(1) THE ARCHITECT/ENGINEER SHALL PREPARE THE ADDENDUM AND A LIST OF ALL PARTIES THAT HAVE PROCURED DRAWINGS AND SPECIFICATIONS FOR THE PROJECT. THE ADDENDUM AND LIST SHALL BE FORWARDED TO THE BUYER IN THE STATE PURCHASING DIVISION. THE ARCHITECT/ENGINEER SHALL ALSO SEND A COPY OF THE ADDENDUM TO THE STATE AGENCY FOR WHICH THE CONTRACT IS ISSUED.</p> <p>(2) THE BUYER SHALL SEND THE ADDENDUM TO ALL INTERESTED PARTIES AND, IF NECESSARY, EXTEND THE BID OPENING DATE. ANY ADDENDUM SHOULD BE RECEIVED BY THE BUYER WITHIN FOURTEEN (14) DAYS PRIOR TO THE BID OPENING DATE.</p> <p>(3) ALL ADDENDA SHOULD BE FORMALLY ACKNOWLEDGED BY ALL BIDDERS AND SUBMITTED TO THE STATE PURCHASING DIVISION. THE SAME RULES AND REGULATIONS THAT APPLY TO THE ORIGINAL BIDDING DOCUMENT SHALL ALSO APPLY TO AN ADDENDUM DOCUMENT. THE ONLY EXCEPTION MAY BE FOR AN ADDENDUM THAT IS ISSUED FOR THE SOLE PURPOSE OF CHANGING A BID OPENING TIME AND/OR DATE.</p> <p>REV. 11/96</p> <p>EXHIBIT 10</p> <p>ADDENDUM ACKNOWLEDGEMENT</p> <p>I HEREBY ACKNOWLEDGE RECEIPT OF THE FOLLOWING CHECKED ADDENDUM(S) AND HAVE MADE THE NECESSARY REVISIONS TO MY PROPOSAL, PLANS AND/OR SPECIFICATION, ETC.</p> <p>ADDENDUM NOS. :</p>						

SEE REVERSE SIDE FOR TERMS AND CONDITIONS

SIGNATURE <i>[Signature]</i>	TELEPHONE 800 962 8618	DATE 04-22-09
TITLE <i>[Signature]</i>	FEIN 550585890	ADDRESS CHANGES TO BE NOTED ABOVE

WHEN RESPONDING TO RFQ, INSERT NAME AND ADDRESS IN SPACE ABOVE LABELED 'VENDOR'



State of West Virginia
 Department of Administration
 Purchasing Division
 2019 Washington Street East
 Post Office Box 50130
 Charleston, WV 25305-0130

Request for Quotation

RFQ NUMBER
 MOC26997

PAGE
 6

ADDRESS CORRESPONDENCE TO ATTENTION OF:
 JOHN ABBOTT
 304-558-2544

RFQ COPY
 TYPE NAME/ADDRESS HERE

Douglas Equipment
 301 North Street
 Bluefield, WV 24701
 (304) 327-0149 1-(800) 962-8618

DIVISION OF CORRECTIONS
 MOUNT OLIVE CORRECTIONAL
 CENTER
 ONE MOUNTAINSIDE WAY
 MT. OLIVE, WV
 25185 304-442-7216

DATE PRINTED	TERMS OF SALE	SHIP VIA	F.O.B.	FREIGHT TERMS
04/17/2009				

BID OPENING DATE: 04/28/2009 BID OPENING TIME 01:30PM

LINE	QUANTITY	UGP	CAT NO	ITEM NUMBER	UNIT PRICE	AMOUNT
NO. 1		yes				
NO. 2		yes				
NO. 3		yes				
NO. 4						
NO. 5						

I UNDERSTAND THAT FAILURE TO CONFIRM THE RECEIPT OF THE ADDENDUM(S) MAY BE CAUSE FOR REJECTION OF THE BIDS.

VENDOR MUST CLEARLY UNDERSTAND THAT ANY VERBAL REPRESENTATION MADE OR ASSUMED TO BE MADE DURING ANY ORAL DISCUSSION HELD BETWEEN VENDOR'S REPRESENTATIVES AND ANY STATE PERSONNEL IS NOT BINDING. ONLY THE INFORMATION ISSUED IN WRITING AND ADDED TO THE SPECIFICATIONS BY AN OFFICIAL ADDENDUM IS BINDING.

.....*J.B. Donovan III*.....SIGNATURE
Douglas Equipment.....COMPANY
April 22, 2009.....DATE

REV. 11/96

APPLICABLE LAW

THE WEST VIRGINIA STATE CODE, PURCHASING DIVISION RULES AND REGULATIONS, AND THE INFORMATION PROVIDED IN THE "REQUEST FOR QUOTATION" ISSUED BY THE PURCHASING

SIGNATURE <i>J.B. Donovan III</i>	TELEPHONE 800 962 8618	DATE 04-22-09
TITLE <i>Gen Mgr</i>	FEIN 55-0585890	ADDRESS CHANGES TO BE NOTED ABOVE

WHEN RESPONDING TO RFQ, INSERT NAME AND ADDRESS IN SPACE ABOVE LABELED 'VENDOR'



State of West Virginia
 Department of Administration
 Purchasing Division
 2019 Washington Street East
 Post Office Box 50130
 Charleston, WV 25305-0130

Request for Quotation

RFQ NUMBER
MOC26997

PAGE
7

ADDRESS: CORRESPONDENCE TO ATTENTION OF
**JOHN ABBOTT
 304-558-2544**

VENDOR

RFQ COPY
 TYPE NAME/ADDRESS HERE

**Douglas Equipment
 301 North Street
 Bluefield, WV 24701
 (304) 327-0149 1-(800) 962-8618**

SHIP TO

**DIVISION OF CORRECTIONS
 MOUNT OLIVE CORRECTIONAL
 CENTER
 ONE MOUNTAINSIDE WAY
 MT. OLIVE, WV
 25185 304-442-7216**

DATE PRINTED	TERMS OF SALE	SHIP VIA	F.O.B.	FREIGHT TERMS
04/17/2009				

BID OPENING DATE: **04/28/2009** BID OPENING TIME: **01:30PM**

LINE	QUANTITY	UOP	CAT NO	ITEM NUMBER	UNIT PRICE	AMOUNT
DIVISION IS THE SOLE AUTHORITY GOVERNING THIS PROCUREMENT.						
***** THIS IS THE END OF RFQ MOC26997 ***** TOTAL:						<u>\$51,278.00</u>

SEE REVERSE SIDE FOR TERMS AND CONDITIONS

SIGNATURE <i>[Signature]</i>	TELEPHONE 800 962 8618	DATE 04-22-09
TITLE <i>[Signature]</i>	FEIN 55-0585890	ADDRESS CHANGES TO BE NOTED ABOVE

WHEN RESPONDING TO RFQ, INSERT NAME AND ADDRESS IN SPACE ABOVE LABELED 'VENDOR'

VENDOR PREFERENCE CERTIFICATE

Certification and application* is hereby made for Preference in accordance with *West Virginia Code*, §5A-3-37. (Does not apply to construction contracts). *West Virginia Code*, §5A-3-37, provides an opportunity for qualifying vendors to request (at the time of bid) preference for their residency status. Such preference is an evaluation method only and will be applied only to the cost bid in accordance with the *West Virginia Code*. This certificate for application is to be used to request such preference. The Purchasing Division will make the determination of the Resident Vendor Preference, if applicable.

- 1. Application is made for 2.5% resident vendor preference for the reason checked:
 Bidder is an individual resident vendor and has resided continuously in West Virginia for four (4) years immediately preceding the date of this certification; or,
 Bidder is a partnership, association or corporation resident vendor and has maintained its headquarters or principal place of business continuously in West Virginia for four (4) years immediately preceding the date of this certification; or 80% of the ownership interest of Bidder is held by another individual, partnership, association or corporation resident vendor who has maintained its headquarters or principal place of business continuously in West Virginia for four (4) years immediately preceding the date of this certification; or,
 Bidder is a nonresident vendor which has an affiliate or subsidiary which employs a minimum of one hundred state residents and which has maintained its headquarters or principal place of business within West Virginia continuously for the four (4) years immediately preceding the date of this certification; or,
- 2. Application is made for 2.5% resident vendor preference for the reason checked:
 Bidder is a resident vendor who certifies that, during the life of the contract, on average at least 75% of the employees working on the project being bid are residents of West Virginia who have resided in the state continuously for the two years immediately preceding submission of this bid; or,
- 3. Application is made for 2.5% resident vendor preference for the reason checked:
 Bidder is a nonresident vendor employing a minimum of one hundred state residents or is a nonresident vendor with an affiliate or subsidiary which maintains its headquarters or principal place of business within West Virginia employing a minimum of one hundred state residents who certifies that, during the life of the contract, on average at least 75% of the employees or Bidder's affiliate's or subsidiary's employees are residents of West Virginia who have resided in the state continuously for the two years immediately preceding submission of this bid; or,
- 4. Application is made for 5% resident vendor preference for the reason checked:
 Bidder meets either the requirement of both subdivisions (1) and (2) or subdivision (1) and (3) as stated above; or,
- 5. Application is made for 3.5% resident vendor preference who is a veteran for the reason checked:
 Bidder is an individual resident vendor who is a veteran of the United States armed forces, the reserves or the National Guard and has resided in West Virginia continuously for the four years immediately preceding the date on which the bid is submitted; or,
- 6. Application is made for 3.5% resident vendor preference who is a veteran for the reason checked:
 Bidder is a resident vendor who is a veteran of the United States armed forces, the reserves or the National Guard, if, for purposes of producing or distributing the commodities or completing the project which is the subject of the vendor's bid and continuously over the entire term of the project, on average at least seventy-five percent of the vendor's employees are residents of West Virginia who have resided in the state continuously for the two immediately preceding years.

Bidder understands if the Secretary of Revenue determines that a Bidder receiving preference has failed to continue to meet the requirements for such preference, the Secretary may order the Director of Purchasing to: (a) reject the bid; or (b) assess a penalty against such Bidder in an amount not to exceed 5% of the bid amount and that such penalty will be paid to the contracting agency or deducted from any unpaid balance on the contract or purchase order.

By submission of this certificate, Bidder agrees to disclose any reasonably requested information to the Purchasing Division and authorizes the Department of Revenue to disclose to the Director of Purchasing appropriate information verifying that Bidder has paid the required business taxes, provided that such information does not contain the amounts of taxes paid nor any other information deemed by the Tax Commissioner to be confidential.

Under penalty of law for false swearing (*West Virginia Code*, §61-5-3), Bidder hereby certifies that this certificate is true and accurate in all respects; and that if a contract is issued to Bidder and if anything contained within this certificate changes during the term of the contract, Bidder will notify the Purchasing Division in writing immediately.

Bidder: DOUGLAS EQUIPMENT

Signed: *P. Ben Sonewant III*

Date: 04-22-09

Title: General Manager

*Check any combination of preference consideration(s) indicated above, which you are entitled to receive.

STATE OF WEST VIRGINIA
Purchasing Division**PURCHASING AFFIDAVIT****VENDOR OWING A DEBT TO THE STATE:**

West Virginia Code §5A-3-10a provides that: No contract or renewal of any contract may be awarded by the state or any of its political subdivisions to any vendor or prospective vendor when the vendor or prospective vendor or a related party to the vendor or prospective vendor is a debtor and the debt owed is an amount greater than one thousand dollars in the aggregate.

PUBLIC IMPROVEMENT CONTRACTS & DRUG-FREE WORKPLACE ACT:

If this is a solicitation for a public improvement construction contract, the vendor, by its signature below, affirms that it has a written plan for a drug-free workplace policy in compliance with Article 1D, Chapter 21 of the *West Virginia Code*. The vendor **must** make said affirmation with its bid submission. Further, public improvement construction contract may not be awarded to a vendor who does not have a written plan for a drug-free workplace policy in compliance with Article 1D, Chapter 21 of the *West Virginia Code* and who has not submitted that plan to the appropriate contracting authority in timely fashion. For a vendor who is a subcontractor, compliance with Section 5, Article 1D, Chapter 21 of the *West Virginia Code* may take place before their work on the public improvement is begun.

ANTITRUST:

In submitting a bid to any agency for the state of West Virginia, the bidder offers and agrees that if the bid is accepted the bidder will convey, sell, assign or transfer to the state of West Virginia all rights, title and interest in and to all causes of action it may now or hereafter acquire under the antitrust laws of the United States and the state of West Virginia for price fixing and/or unreasonable restraints of trade relating to the particular commodities or services purchased or acquired by the state of West Virginia. Such assignment shall be made and become effective at the time the purchasing agency tenders the initial payment to the bidder.

I certify that this bid is made without prior understanding, agreement, or connection with any corporation, firm, limited liability company, partnership or person or entity submitting a bid for the same materials, supplies, equipment or services and is in all respects fair and without collusion or fraud. I further certify that I am authorized to sign the certification on behalf of the bidder or this bid.

LICENSING:

Vendors must be licensed and in good standing in accordance with any and all state and local laws and requirements by any state or local agency of West Virginia, including, but not limited to, the West Virginia Secretary of State's Office, the West Virginia Tax Department, West Virginia Insurance Commission, or any other state agencies or political subdivision. Furthermore, the vendor must provide all necessary releases to obtain information to enable the Director or spending unit to verify that the vendor is licensed and in good standing with the above entities.

CONFIDENTIALITY:

The vendor agrees that he or she will not disclose to anyone, directly or indirectly, any such personally identifiable information or other confidential information gained from the agency, unless the individual who is the subject of the information consents to the disclosure in writing or the disclosure is made pursuant to the agency's policies, procedures and rules. Vendor further agrees to comply with the Confidentiality Policies and Information Security Accountability Requirements, set forth in <http://www.state.wv.us/admin/purchase/privacy/noticeConfidentiality.pdf>.

Under penalty of law for false swearing (*West Virginia Code* §61-5-3), it is hereby certified that the vendor affirms and acknowledges the information in this affidavit and is in compliance with the requirements as stated.

Vendor's Name: DOUGLAS EQUIPMENT

Authorized Signature: *J. Ben Donerant III* Date: 04-22-09

Purchasing Affidavit (Revised 01/01/09)

General Manager



State of West Virginia
 Department of Administration
 Purchasing Division
 2019 Washington Street East
 Post Office Box 50130
 Charleston, WV 25305-0130

Request for Quotation

RFQ NUMBER
 MOC26997

PAGE
 1

ADDRESS CORRESPONDENCE TO ATTENTION OF:
 JOHN ABBOTT
 304-558-2544

RFQ COPY
 TYPE NAME/ADDRESS HERE

Douglas Equipment
 301 North Street
 Bluefield, WV 24701
 (304) 327-0149 1-(800) 962-8618

SHIP TO

DIVISION OF CORRECTIONS
 MOUNT OLIVE CORRECTIONAL
 CENTER
 ONE MOUNTAINSIDE WAY
 MT. OLIVE, WV
 25185 304-442-7216

DATE PRINTED	TERMS OF SALE	SHIP VIA	F.O.B.	FREIGHT TERMS
04/17/2009				

BID OPENING DATE: 04/28/2009 BID OPENING TIME 01:30PM

LINE	QUANTITY	UOP	CAT NO	ITEM NUMBER	UNIT PRICE	AMOUNT
------	----------	-----	--------	-------------	------------	--------

0001	2	EA		165-85		
				ADDENDUM #01		
				THIS ADDENDUM IS ISSUED TO ADD THE PREVAILING WAGE RATE DUE TO THE THE REQUIREMENT "VENDOR MUST SECURE STEAMER THE FLOOR", PER THE BELOW; AND TO ADD THE REQUIREMENT "INSTALLATION MUST BE SCHEDULED AFTER DINNER, OR 6:00 PM, IN ORDER TO AVOID DISRUPTION IN THE MEAL PREPARATION. GAS HOOK UP WILL BE PERFORMED BY AGENCY STAFF.		
					LABORER CLASS II FAYETTE COUNTY \$21.44 HR + \$10.12 FRINGE BENEFITS	
					THIS AMOUNT ADDED INTO TOTAL BID PRICE (HOURLY RATE)	
				WEST VIRGINIA CODE 21-1D-5 PROVIDES THAT: ANY SOLICITATION FOR A PUBLIC IMPROVEMENT CONSTRUCTION CONTRACT REQUIRES EACH VENDOR THAT SUBMITS A BID FOR THE WORK TO SUBMIT AT THE SAME TIME AN AFFIDAVIT OF COMPLIANCE WITH THE BID. THE ENCLOSED DRUG-FREE WORKPLACE AFFIDAVIT MUST BE SIGNED AND SUBMITTED WITH THE BID AS EVIDENCE OF THE VENDOR'S COMPLIANCE WITH THE PROVISIONS OF ARTICLE 1D, CHAPTER 21 OF THE WEST VIRGINIA CODE. FAILURE TO SUBMIT THE SIGNED DRUG-FREE WORKPLACE AFFIDAVIT WITH THE BID SHALL RESULT IN DISQUALIFICATION OF SUCH BID.		
				NOTICE TO PROCEED: THIS CONTRACT IS TO BE PERFORMED WITHIN 30 CALENDAR DAYS AFTER THE NOTICE TO PROCEED IS RECEIVED. UNLESS OTHERWISE SPECIFIED, THE FULLY EXECUTED PURCHASE ORDER WILL BE CONSIDERED NOTICE TO PROCEED.		

SEE REVERSE SIDE FOR TERMS AND CONDITIONS

SIGNATURE <i>J. B. Donovan III</i>	TELEPHONE 800 962 8618	DATE 04-22-09
TITLE <i>J. B. Donovan</i>	FEIN 55-0585890	ADDRESS CHANGES TO BE NOTED ABOVE

WHEN RESPONDING TO RFQ, INSERT NAME AND ADDRESS IN SPACE ABOVE LABELED 'VENDOR'

WEST VIRGINIA DIVISION OF LABOR
Building Construction Wage Rates

FILED
2008 JAN -3 PM 12:57

Fayette County
2008

OFFICE OF THE
SECRETARY OF STATE

CLASSIFICATION	BASIC HOURLY RATE	FRINGE BENEFITS
ASBESTOS & LEAD ABATEMENT WORKER	20.00	8.27
BOILERMAKER	32.04	15.56
BRICKLAYER	25.39	14.57
BRICKLAYER - POINTER/CAULKER/CLEANER	25.39	14.57
CARPENTER	24.62	13.44
CARPET LAYER	24.62	13.44
CEMENT MASON	26.07	10.66
DRYWALL HANGER	24.62	13.44
ELECTRICIAN	30.45	12.74
ELEVATOR HELPER	25.41	16.47
ELEVATOR MECHANIC	36.30	16.47
GLAZIER	26.50	5.83
INSULATOR	27.83	14.90
IRON WORKER ERECTOR *	23.46	15.71
IRON WORKER FENCE ERECTOR *	23.46	15.71
IRON WORKER JOURNEYMAN *	23.46	15.71
IRON WORKER REINFORCING *	23.46	15.71
IRON WORKER SHEETER *	23.46	15.71
IRON WORKER STRUCTURAL *	23.46	15.71
LABORER CLASS I *	22.28	10.12
LABORER CLASS II *	21.44	10.12
LABORER CLASS III *	20.82	10.12
LATHER	24.62	13.44
MARBLE FINISHER	20.40	8.58
MARBLE SETTER	25.39	14.57
MILLWRIGHT	27.64	13.83
OPERATING ENGINEER I *	27.36	16.18
OPERATING ENGINEER II *	27.01	16.18
OPERATING ENGINEER III *	26.01	16.18
OPERATING ENGINEER IV *	21.41	16.18
PAINTER	22.08	10.12
PILEDRIVER	24.87	13.44
PLASTERER	28.06	9.68
PLUMBER/FITTER	27.34	14.21
ROOFER/HEATED COAL TAR PRODUCT	26.23	9.98
ROOFER/WATER DAMP PROOFER	24.90	9.98
SHEET METAL WORKER	24.10	16.19



State of West Virginia
 Department of Administration
 Purchasing Division
 2019 Washington Street East
 Post Office Box 50130
 Charleston, WV 25305-0130

Request for Quotation

RFQ NUMBER
 MOC26997

PAGE
 2

ADDRESS CORRESPONDENCE TO ATTENTION OF
 JOHN ABBOTT
 304-558-2544

RFQ COPY
 TYPE NAME/ADDRESS HERE

Douglas Equipment
 301 North Street
 Bluefield, WV 24701
 (304) 327-0149 1-(800) 962-8618

DIVISION OF CORRECTIONS
 MOUNT OLIVE CORRECTIONAL
 CENTER
 ONE MOUNTAINSIDE WAY
 MT. OLIVE, WV
 25185 304-442-7216

DATE PRINTED	TERMS OF SALE	SHIP VIA	F.O.B.	FREIGHT TERMS
04/17/2009				

BID OPENING DATE: 04/28/2009 BID OPENING TIME 01:30PM

LINE	QUANTITY	UOP	CAT NO	ITEM NUMBER	UNIT PRICE	AMOUNT
<p>CANCELLATION: THE DIRECTOR OF PURCHASING RESERVES THE RIGHT TO CANCEL THIS CONTRACT IMMEDIATELY UPON WRITTEN NOTICE TO THE VENDOR IF THE MATERIALS OR WORKMANSHIP SUPPLIED ARE OF AN INFERIOR QUALITY OR DO NOT CONFORM WITH THE SPECIFICATIONS OF THE BID AND CONTRACT HERE IN.</p> <p>WAGE RATES: THE CONTRACTOR OR SUBCONTRACTOR SHALL PAY THE HIGHER OF THE U.S. DEPARTMENT OF LABOR MINIMUM WAGE RATES AS ESTABLISHED FOR FAYETTE COUNTY, PURSUANT TO WEST VIRGINIA CODE 21-5A, ET, SEQ. (PREVAILING WAGE RATES APPLY TO THIS PROJECT)</p> <p>ARBITRATION: ANY REFERENCES MADE TO ARBITRATION OR INTEREST FOR PAYMENTS DUE (EXCEPT FOR ANY INTEREST REQUIRED BY STATE LAW) CONTAINED IN THIS CONTRACT OR IN ANY AMERICAN INSTITUTE OF ARCHITECTS DOCUMENTS PERTAINING TO THIS CONTRACT ARE HEREBY DELETED.</p> <p>WORKERS' COMPENSATION: VENDOR IS REQUIRED TO PROVIDE A CERTIFICATE FROM WORKERS' COMPENSATION IF SUCCESSFUL.</p> <p>ALL OF THE ITEMS CHECKED BELOW WILL BE A REQUIREMENT OF THIS CONTRACT:</p> <p>(XX) INSURANCE: SUCCESSFUL VENDOR SHALL FURNISH PROOF OF COMMERCIAL GENERAL LIABILITY INSURANCE PRIOR TO ISSUANCE OF CONTRACT. UNLESS OTHERWISE SPECIFIED IN THE BID DOCUMENTS, THE MINIMUM AMOUNT OF INSURANCE COVERAGE REQUIRED IS \$250,000.</p> <p>() BUILDERS RISK INSURANCE: SUCCESSFUL VENDOR SHALL FURNISH PROOF OF BUILDERS RISK - ALL RISK INSURANCE IN AN AMOUNT EQUAL TO 100% OF THE AMOUNT OF THE CONTRACT.</p>						

SEE REVERSE SIDE FOR TERMS AND CONDITIONS

SIGNATURE <i>J. B. Donovan III</i>	TELEPHONE 800 962 8618	DATE 04-22-09
TITLE <i>Gen Mgr</i>	FEIN 55-0585890	ADDRESS CHANGES TO BE NOTED ABOVE

WHEN RESPONDING TO RFQ, INSERT NAME AND ADDRESS IN SPACE ABOVE LABELED 'VENDOR'



State of West Virginia
 Department of Administration
 Purchasing Division
 2019 Washington Street East
 Post Office Box 50130
 Charleston, WV 25305-0130

Request for Quotation

RFQ NUMBER
 MOC26997

PAGE
 1

ADDRESS CORRESPONDENCE TO ATTENTION OF
 JOHN ABBOTT
 304-558-2544

RFQ COPY
 TYPE NAME/ADDRESS HERE

Douglas Equipment
 301 North Street
 Bluefield, WV 24701
 (304) 327-0149 1-(800) 962-8618

DIVISION OF CORRECTIONS
 MOUNT OLIVE CORRECTIONAL
 CENTER
 ONE MOUNTAINSIDE WAY
 MT. OLIVE, WV
 25185 304-442-7216

DATE PRINTED	TERMS OF SALE	SHIP VIA	FOB	FREIGHT TERMS
04/23/2009				

BID OPENING DATE: 05/05/2009 BID OPENING TIME 01:30PM

LINE	QUANTITY	UOP	CAT NO.	ITEM NUMBER	UNIT PRICE	AMOUNT
0001				165-85		
ADDENDUM #02 THIS ADDENDUM IS ISSUED TO CHANGE THE QUANTITY REQUIRED FOR THIS REQUEST FOR QUOTATION; AND TO EXTEND THE BID OPENING FROM 4/28/2009 TO 5/5/2009; 1:30 PM VENDORS SHALL QUOTE TWO (2) TILTING KETTLES AND ONE (1) DOUBLE STACK STEAMER, PER THE REVISED ATTACHED BID FORM.						
***** THIS IS THE END OF RFQ MOC26997 *****						TOTAL: <u>\$51,278.00</u>

SEE REVERSE SIDE FOR TERMS AND CONDITIONS

SIGNATURE: *BJ Donovan III* TELEPHONE: 800.962.8618 DATE: 04.27.09

TITLE: *Buyer* FEIN: 55-0585890 ADDRESS CHANGES TO BE NOTED ABOVE

WHEN RESPONDING TO RFQ, INSERT NAME AND ADDRESS IN SPACE ABOVE LABELED 'VENDOR'

MOC26997 - Commercial Kitchen Equipment - BID FORM		
Description	Order Qty.	Extended Price
Double Stack Convection Steamer	1	\$ 14,262.00
Tilting Kettle	2	\$ 37,016.00
Failure to use this form may result in disqualification		\$ 51,278.00
Bidder / Vendor Information:		
Name:	J. BEN DONEVANT III GEN. MGR	
Address:	DOUGLAS EQUIPMENT 301 NORTH ST. BLUEFIELD, WV 24701	
Phone# :	800.967.8618	
Email Address:	BEN@DOUGLASEQUIPMENT. us	
Revised 4/23/2009		

Item #1

STEAMER, CONVECTION, GAS, FLOOR MODEL

Convection Steamer, gas, 2 compartment, 24" cabinet base, six 12 x 20 x 2-1/2" pan/compartment capacity, twin gas-fired generators w/individual electronic ignition system, 190,000 BTU

Gas type to be specified

120v/60/1-ph

91-6852 Kleensteam, includes 2 yr. boiler warranty, 7CB5 cartridge, SS-10 scale inhibitor cartridge, (4) ScaleKleen 2.2 lb packets & dip tube

PRISON PACKAGE Consists of:

*A Lockable Stainless Steel Hinged Cover over the Cooker Controls

*Lockable Modular Cabinet Base Doors. Side and Rear Panels Secured to the SS Base Frame with Tamper Proof Screws.

*Four (4) Flanged Feet for Securing the Unit to the Floor

*All Exposed Screws to be Tamper Proof

Note: Locks are Not Included

Weight: 1510 lbs. total

One (1) Year Parts & Labor Warranty, and Free Mechanical Start-Up included in pricing.

FOR
ADDENDUM # 2

G**12 PAN GAS CONVECTION
STEAMER WITH TWIN
GAS GENERATOR**JOB NAME: MOUNT OLIVE PRISON
ITEM NO.: _____
NO. REQUIRED: 1 DOUBLE STACKMODEL: ST-12-TGGSIZE: 24" Wide x 76" High x 39" Front-to-Back
(610mm Wide x 1931mm High x 991mm Front-to-Back)**DESCRIPTION:** Shall be a Market Forge Model ST-12-TGG gas fired convection steam cooker. Will be integrally mounted on a cabinet base containing individual gas fired steam generators.

The ST-12-TGG will be of double-wall construction with 1" (25mm) thick insulation between cooking compartments and exterior walls, and will have two 18 gauge stainless steel welded cooking compartments with coved internal corners, and a 16 gauge stainless steel front panel.

Each cooking compartment on the ST-12-TGG has a positive slam action, field-reversible door constructed of Type 304 stainless steel. Door latches are spring loaded. The inner door gasket is a one-piece NSF-approved silicone rubber gasket. Factory installs units with the door opening from the right, see diagram.

Each compartment will be equipped with two steam inlets positioned precisely to ensure even steam cooking across all food products. Controls for each compartment will include a 60-minute load compensating timer with constant steam position, on/off power switch, pilot ready light, pilot cooking light, pilot ignition light, vacuum breaker, an automatic cold water steam condenser system, and a removable drip trough.

Each compartment will be independently and automatically controlled by setting the cooking time on the 60-minute timer. At the end of cooking cycle, the pilot cooking light will turn off and a continuous signal will sound. Signal is silenced by returning the timer to the OFF position.

Stainless steel cabinet base will match other Market Forge stainless steel equipment and enclose steam generators. Base will be equipped with 6" (152mm) stainless steel legs and adjustable bullet feet, reinforced stainless steel counter-top, and hinged door(s) with magnetic catches.

The steam generators will be automatically filled with water and brought to a ready position when the power switches are turned on and automatically drain when the power switches are turned off. A cold water condenser will automatically condense all exhausted steam into water before it is released from the cooker and steam generator drain. Unit also includes, low water cut-off and also includes an access for Total Concept delimer/descaler. For ease of serviceability, generator controls are conveniently located on the right side of steamer enclosure.

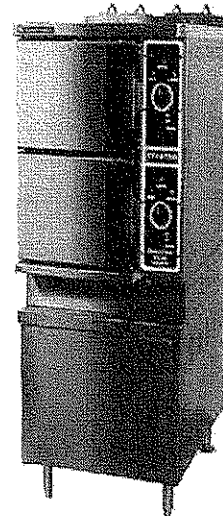

ST-12-TGG Shown

COOKING CAPACITIES:

Each compartment will accommodate the following:

- (12) 12" x 20" x 1" deep pans
- (6) 12" x 20" x 2 1/2" deep pans
- (4) 12" x 20" x 4" deep pans

STANDARD FEATURES:

- Automatic blow down.
- Load Compensating Timers.
- Thermostatically controlled drain
- Single connection for drain plumbing
- Reversible Door capabilities.
- Redundant controls and generators for each compartment.
- All stainless steel construction for generators and cabinet.
- Steam Generator Interlock Switch.
- Left side access panel.
- Delimiting ports on front of each generator.
- Split water lines.
- Rear flanged feet.
- Electronic ignition.

OPERATION SHALL BE BY:

Two gas fired, stainless steel steam generators operating at 0 PSI and rated at 95,000 BTU's each.

The gas generators shall be equipped for operation on:

- Natural gas
- LP. gas

The controls shall be equipped for operation on:

- 115 VAC, 1 Phase, 50/60 Hz

OPTIONAL ITEMS AT EXTRA COST:

- 220 VAC, 1 Phase, 50/60 Hz.
- Flanged Feet (Front Legs).
- Water Filter System.
- Casters (2 w/brakes).

The manufacturer reserves the right to modify materials and specifications without notice.

Spec No. S-4637
02/04FOOD SERVICE EQUIPMENT
12 Pan Convection Steamer

AutoQuotes

**MARKET FORGE**
INDUSTRIES INC.

An Employee Owned Company

35 Garvey Street • Everett • MA • 02149
Tel: (617) 387-4100 • Fax: 1-800-227-2659 (Ex. MA) • (617) 387-4456 (MA and Overseas)
E-Mail: CUSTSERV@mfi.com • Website: www.mfi.com

G**12 PAN GAS CONVECTION STEAMER WITH TWIN GAS GENERATOR****DETAILS & DIMENSION****WATER QUALITY STATEMENT FOR GENERATOR**

Water quality is the major factor affecting the performance of your appliance. If you are unsure of water quality, consult a local water treatment specialist and have the water analyzed. Your water must be within these general guidelines:

Total Dissolved Solids	Less than 60 PPM
Total Alkalinity	Less than 20 PPM
Silica	Less than 13 PPM
Chlorine	Less than 1.5 PPM
pH Factor	7.0-8.5

Water which fails to meet these standards should be treated by installation of water conditioner. **FAILURE OR MALFUNCTION OF THIS APPLIANCE DUE TO POOR WATER QUALITY IS NOT COVERED UNDER WARRANTY.**

MODEL	FUEL	BTU	GAS SUPPLY
ST-12-TGG	Natural Gas Propane	190,000 190,000	Min. 6" (152mm)

SERVICE CONNECTIONS**Gas Operated**

E	Electrical Connection - to be 120 Volts, 60 Hz, 1 Ph with Ground. Unless otherwise specified, Furnished with 4 1/2" (114mm) cord with 3 pronged plug. Max Amps 4.0.
G	Gas Connection - 3/4" (19mm) IPS supply line required.
D	Drain - 2" (51mm) IPS piped to open floor drain. NO SOLID CONNECTION. Max 24" (610mm) length before open air gap. NO BENDS OR ELBOWS.
CW	Condensing Cold Water - 3/8" (9mm) O.D. tubing. Water Pressure 25 PSI Min., 50 PSI Max.
GW	Generator Water - 3/8" (9mm) O.D. tubing. Water Pressure 25 PSI Min., 50 PSI Max.

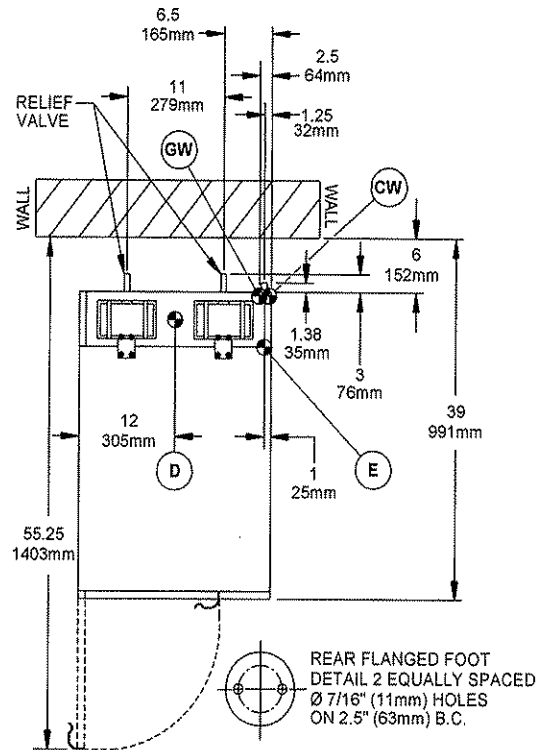
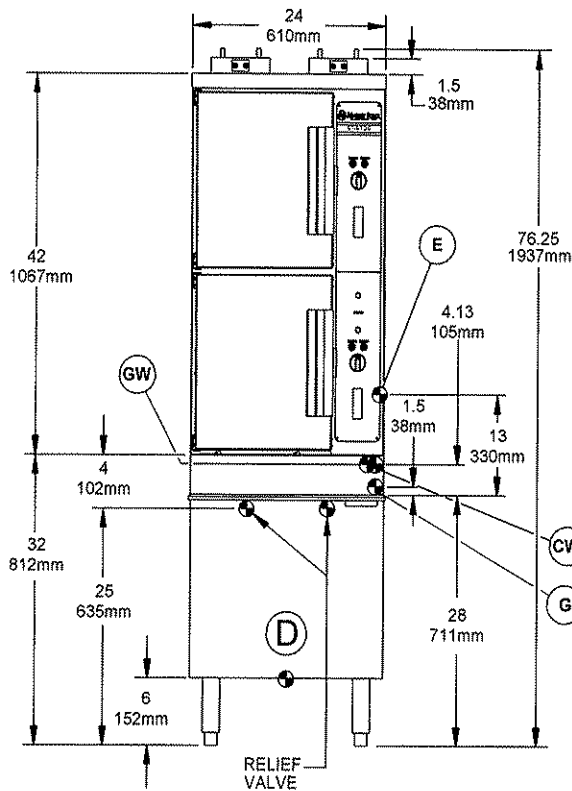

*It is our policy to build equipment which is design certified by A.G.A., N.S.F., and C.G.A. However, a continuing program of product improvement makes it necessary to submit new models to the agencies as they are developed and consequently not all models bear the appropriate agency labels at all times.

Spec No. S-4637
02/04FOOD SERVICE EQUIPMENT
12 Pan Convection Steamer**MARKET FORGE**
INDUSTRIES INC.

An Employee Owned Company



Printed in U.S.A.

35 Garvey Street • Everett • MA • 02149
 Tel: (617) 387-4100 • Fax: 1-800-227-2659 (Ex. MA) • (617) 387-4456 (MA and Overseas)
 E-Mail: CUSTSERV@mfi.com • Website: www.mfi.com

Item #2

2

TILTING KETTLE, GAS

Kettle, tilting, gas, 60-gallon capacity, 2/3 steam jacket design, open leg base, all stainless steel exterior finish, 120,000 BTU

Gas type to be specified

120w/60-50/1ph, std.

08-001† Tangent Draw-Off Valve, 3", for tilting kettles (not available on modular kettles)

~~09-1116 Lift-Off Cover, for 60-gallon tilting kettle~~

includes pt ren

09-1125 Hinged Cover, for 60 gallon tilting kettle

PRISON PACKAGE Consists of:

*Lockable Stainless Steel Hinged Cover over the Control Panel **Lock Not Included

*All Exposed Screws will be Tamper Proof Tack Welds where Applicable

Weight: 2000 lbs. total

One (1) Year Parts & Labor Warranty, and Free Mechanical Start-Up included in pricing.

FOR
ADDENDUM # 2

G**TILTING SELF CONTAINED
GAS FIRED STEAM
JACKETED KETTLE**JOB NAME: Mount Olive Prison
ITEM NO.: 1
NO. REQUIRED: 2MODEL: FT-20GL
 FT-30GL
 FT-40GL
 FT-60GLSIZE: 20 Gallon (76 liters) capacity
 30 Gallon (114 liters) capacity
 40 Gallon (152 liters) capacity
 60 Gallon (227 liters) capacity**DESCRIPTION:**

The kettle has double-wall construction of 300 series stainless steel forming a steam jacket around the lower 2/3 of the kettle. The jacket enclosure contains factory sealed water and antifreeze. The kettle exterior is fully insulated. The bottom of the kettle is a hemispherical design for superior heat circulation. The recessed control panel is located on the front right side of the unit in full view of the operator. Standard controls include direct immersion thermostat, water sight glass, cooking light, pressure gauge and electronic ignition with ignition indicator light. Safety features include low water cutoff with indicator light, pressure switch, pressure relief valve and a 100% safety gas shut off valve.

The kettle pivots on trunnions connected to the gear and control consoles. The worm and gear tilting mechanism allows the kettle to tilt forward to a full 90° for complete draining. The tilt mechanism is self locking for positive stop action. The consoles are drip proof, stainless steel clad and are supported on all welded 1 5/8" (41mm) diameter stainless steel legs with flanged feet.

The kettle construction is stainless steel throughout and built in accordance with the ASME code.

KETTLE SIZE	INPUT BTU/HR	COMBUSTION EFFICIENCY
20 Gallon (76 Liters)	80,000	78% Min.
30 Gallon (114 Liters)	100,000	78% Min.
40 Gallon (152 Liters)	100,000	75% Min.
60 Gallon (227 Liters)	120,000	75% Min.

The manufacturer reserves the right to modify materials and specifications without notice

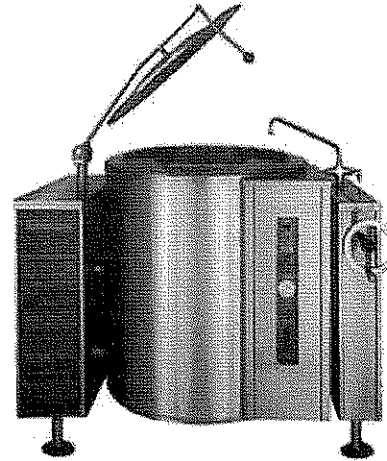

FT-40GL Shown with Optional Spring Assist Cover & Faucet

OPERATION SHALL BE BY:

Natural or L.P. gas utilizing a high efficiency power burner system. The steam kettle is A.S.M.E. code stamped for operation to 50 PSI. Temperature range from 150° F to 285° F.

The controls shall be equipped for operation on:
 120 VAC, 1pH, 50/60 Hz.

OPTIONAL AT EXTRA COST:

- Spring assist cover, HSC
- 2" tangent draw off, FDOR-2
- 3" tangent draw off, FDOR-3
- Tri-Basket assembly
- Single pantry faucet with swing spout, SP-12
- Double pantry faucet with swing spout, DP-12
- Graduated measuring strip, MS-1
- Perforated strainer
- Solid disk strainer DOS-2
- 316 stainless steel liner for high acid content products.

Spec No. S-2426
02/04FOOD SERVICE EQUIPMENT
Tilting Gas Kettle**MARKET FORGE**
INDUSTRIES INC.*An Employee Owned Company*

Printed in U.S.A.

35 Garvey Street • Everett • MA • 02149
Tel: (617) 387-4100 • Fax: 1-800-227-2659 (Ex. MA) • (617) 387-4456 (MA and Overseas)
E-Mail: CUSTSERV@mfi.com • Website: www.mfi.com

G**TILTING SELF CONTAINED
GAS FIRED STEAM
JACKETED KETTLE****DETAILS & DIMENSION****ELECTRICAL OPTIONS:**

- ☐ 208 Volts, 60Hz, 1Ph or for use on 190 to 219 Volts supply unit. Total Max. Amps 1.0.
- ☐ 236 Volts, 60Hz, 1Ph or for use on 220 to 240 Volts supply unit. Total Max. Amps 1.0.
- ☐ 220 Volts, 50Hz, 1Ph or for use on 220 to 240 Volts supply unit. Total Max. Amps 1.0.

SERVICE CONNECTIONS**Gas Operated**

EC	Electrical Connection - 115 Volt, 60Hz, 1Ph, furnished with 6 ft. cord with 3 pronged plug. Total Max. Amps 2.0.
G	Gas Connection - 3/4" (19mm) N.P.T.

NOTE: Allow 6" (152mm) Min. spacing on left and right sides and 2" (51mm) spacing from flue.

MODEL	CAPACITY		A	B	C	D	E	F	G	H	J	K	L	M
FT-20GL	20 Gallons 76 liters	inches mm	20 508	48.125 1222	40.375 1032	19 483	40.5 1020	76.5 1943	16.5 419	24 610	11 280	10 254	32 813	30.5 775
FT-30GL	30 Gallons 114 liters	inches mm	26 660	54.25 1378	43.375 1108	16.5 419	37.25 946	73.75 1874	15.5 394	22.25 565	7.5 190	11 280	34 864	29.5 749
FT-40GL	40 Gallons 152 liters	inches mm	26 660	54.25 1378	43.375 1108	16.5 419	41.5 1054	76 1930	15.5 394	22.25 565	7.5 190	12 305	35 889	30.5 775
FT-60GL	60 Gallons 227 liters	inches mm	30 762	58.125 1378	43.375 1108	17.875 454	45.5 1156	82 2083	19.5 496	22.25 565	5.5 140	15 381	38 965	30.375 772

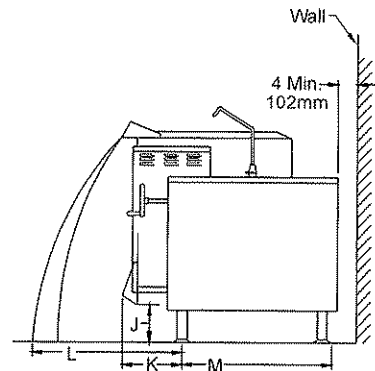
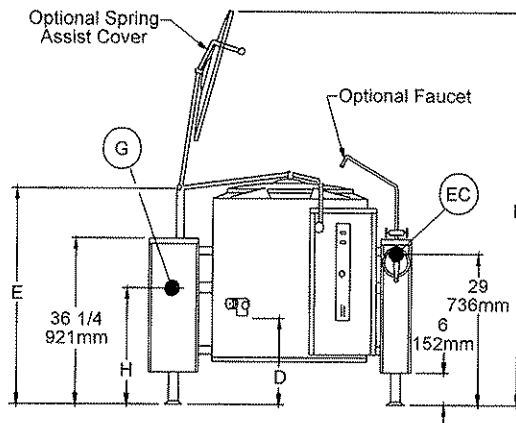
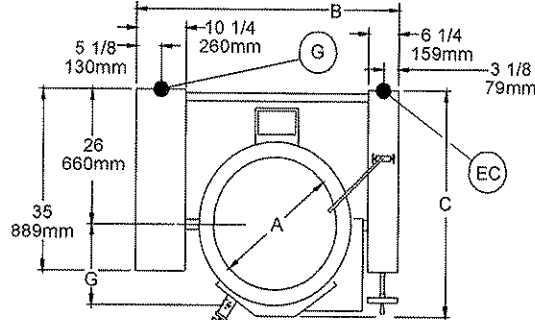

*It is our policy to build equipment which is design certified by U.L., E.T.L., A.S.M.E., N.S.F. and C.S.A. However, a continuing program of product improvement makes it necessary to submit new models to the agencies as they are developed and consequently not all models bear the appropriate agency labels at all times.



MARKET FORGE
INDUSTRIES INC.

An Employee Owned Company



Printed in U.S.A.

35 Garvey Street • Everett • MA • 02149
Tel: (617) 387-4100 • Fax: 1-800-227-2659 (Ex. MA) • (617) 387-4456 (MA and Overseas)
E-Mail: CUSTSERV@mfi.com • Website: www.mfi.com

Spec No. S-2426
02/04

FOOD SERVICE EQUIPMENT
Tilting Gas Kettle



State of West Virginia
 Department of Administration
 Purchasing Division
 2019 Washington Street East
 Post Office Box 50130
 Charleston, WV 25305-0130

Request for Quotation

RFQ NUMBER
 MOC26997

PAGE
 1

ADDRESS CORRESPONDENCE TO ATTENTION OF:
 JOHN ABBOTT
 304-558-2544

VENDOR *709045518 304-327-0149
 DOUGLAS EQUIPMENT
 301 NORTH STREET
 BLUEFIELD WV 24701-4048

SHIP TO DIVISION OF CORRECTIONS
 MOUNT OLIVE CORRECTIONAL
 CENTER
 ONE MOUNTAINSIDE WAY
 MT. OLIVE, WV
 25185 304-442-7216

DATE PRINTED	TERMS OF SALE	SHIP VIA	F.O.B.	FREIGHT TERMS
04/24/2009				

BID OPENING DATE: 05/05/2009 BID OPENING TIME 01:30PM

LINE	QUANTITY	UOP	CAT NO	ITEM NUMBER	UNIT PRICE	AMOUNT
0001				165-85		
ADDENDUM #03 THIS ADDENDUM IS ISSUED TO ADD THE DRUG FREE COMPLIANCE AFFIDAVIT, WHICH IS REQUIRED WITH THE BID. FAILURE TO RETURN THIS EXECUTED FORM WITH YOUR BID IS AUTOMATIC DISQUALIFICATION. ATTACHMENT: DRUG FREE COMPLIANCE AFFIDAVIT STEAM COOKERS						
***** THIS IS THE END OF RFQ MOC26997 ***** TOTAL:						\$51,278.00

SEE REVERSE SIDE FOR TERMS AND CONDITIONS

SIGNATURE *JB Donovant III* TELEPHONE 800.967.8618 DATE 04-27-09
 TITLE *Gen Mgr* FEIN 55-0585890 ADDRESS CHANGES TO BE NOTED ABOVE

WHEN RESPONDING TO RFQ, INSERT NAME AND ADDRESS IN SPACE ABOVE LABELED 'VENDOR'



State of West Virginia
DRUG FREE WORKPLACE CONFORMANCE AFFIDAVIT
West Virginia Code §21-1D-5

STATE OF WEST VIRGINIA

COUNTY OF MERCER, TO-WIT:

I, J. BEN DONEWANT III, after being first duly sworn, depose and state as follows:

- 1. I am an employee of DOUGLAS EQUIPMENT; and,
(Company Name)
- 2. I do hereby attest that DOUGLAS EQUIPMENT
(Company Name)

maintains a valid written drug free workplace policy and that such policy is in compliance with **West Virginia Code §21-1D-5**.

The above statements are sworn to under the penalty of perjury.

DOUGLAS EQUIPMENT
(Company Name)

By: J. B. Donevant III

Title: GENERAL MANAGER

Date: 04-27-09

Taken, subscribed and sworn to before me this 27th day of April, 2009

By Commission expires April 17, 2016

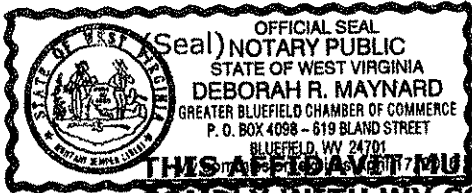

Deborah R. Maynard
(Notary Public)

THIS AFFIDAVIT MUST BE SUBMITTED WITH THE BID IN ORDER TO COMPLY WITH WV CODE PROVISIONS. FAILURE TO INCLUDE THE AFFIDAVIT WITH THE BID SHALL RESULT IN DISQUALIFICATION OF THE BID.