



State of West Virginia
 Department of Administration
 Purchasing Division
 2019 Washington Street East
 Post Office Box 50130
 Charleston, WV 25305-0130

Request for Quotation

RFQ NUMBER
DNR209112

PAGE
1

ADDRESS CORRESPONDENCE TO ATTENTION OF
**FRANK WHITTAKER
 304-558-2316**

VENDOR

*702142549 304-428-3000
DAVIS ATHLETICS LLC
2325 LIBERTY ST

PARKERSBURG WV 26101

SHIP TO

DIVISION OF NATURAL RESOURCES
PIPESTEM STATE PARK
ATTN: PARK SUPERINTENDENT
STATE ROUTE 20
PIPESTEM, WV
25979 304-466-2804

DATE PRINTED	TERMS OF SALE	SHIP VIA	F.O.B.	FREIGHT TERMS
05/05/2009				

BID OPENING DATE: **06/10/2009** BID OPENING TIME **01:30PM**

LINE	QUANTITY	UOP	CAT NO	ITEM NUMBER	UNIT PRICE	AMOUNT
0001	1	LS		650-38		\$61,480.23
<p>PLAYGROUND EQUIPMENT (NOT OTHERWISE CLASSIFIED)</p> <p>THE WEST VIRGINIA PURCHASING DIVISION, FOR THE AGENCY, THE WEST VIRGINIA DIVISION OF NATURAL RESOURCES, IS SOLICITING BIDS FROM RESPONSIBLE VENDORS FOR PLAYGROUND EQUIPMENT FOR PIPESTEM STATE PARK PER THE ATTACHED SPECIFICATIONS.</p> <p>A MANDATORY PRE-BID MEETING WILL BE HELD MAY 19, 2009 AT 10:00 AM AT THE PARK HEADQUARTERS. FAILURE TO ATTEND THE MANDATORY PRE-BID MEETING WILL RESULT IN BID DISQUALIFICATION. AN INDIVIDUAL MAY NOT REPRESENT MORE THAN ONE VENDOR AT THE PRE-BID MEETING.</p> <p>ALL TECHNICAL QUESTIONS MUST BE SUBMITTED IN WRITING TO FRANK WHITTAKER IN THE PURCHASING DIVISION VIA FAX AT 304-558-4115 OR VIA EMAIL AT FRANK.M.WHITTAKER@WV.GOV DEADLINE FOR TECHNICAL QUESTIONS IS 05/21/09 AT 3:00 PM ALL TECHNICAL QUESTIONS WILL BE ANSWERED BY ADDENDUM AFTER THE DEADLINE.</p> <p>BANKRUPTCY: IN THE EVENT THE VENDOR/CONTRACTOR FILES FOR BANKRUPTCY PROTECTION, THIS CONTRACT MAY BE DEEMED NULL AND VOID, AND TERMINATED WITHOUT FURTHER ORDER.</p> <p>THE MODEL/BRAND/SPECIFICATIONS NAMED HEREIN ESTABLISH THE ACCEPTABLE LEVEL OF QUALITY ONLY AND ARE NOT INTENDED TO REFLECT A PREFERENCE OR FAVOR ANY PARTICULAR BRAND OR VENDOR. VENDORS WHO ARE BIDDING ALTERNATES SHOULD SO STATE AND INCLUDE PERTINENT</p>						

RECEIVED

2009 JUN 10 P 9:57

PURCHASING DIVISION
 STATE OF WV

SEE REVERSE SIDE FOR TERMS AND CONDITIONS

SIGNATURE <i>Med L Davis</i>	TELEPHONE 304-428-3000	DATE 6/9/09
TITLE Owner	FEIN 41-2171922	ADDRESS CHANGES TO BE NOTED ABOVE

WHEN RESPONDING TO RFQ, INSERT NAME AND ADDRESS IN SPACE ABOVE LABELED 'VENDOR'



State of West Virginia
 Department of Administration
 Purchasing Division
 2019 Washington Street East
 Post Office Box 50130
 Charleston, WV 25305-0130

Request for Quotation

RFQ NUMBER:
DNR209112

PAGE
2

ADDRESS CORRESPONDENCE TO ATTENTION OF
**FRANK WHITTAKER
 304-558-2316**

VENDOR

*702142549 304-428-3000
DAVIS ATHLETICS LLC
2325 LIBERTY ST

PARKERSBURG WV 26101

SHIP TO

**DIVISION OF NATURAL RESOURCES
 PIPESTEM STATE PARK
 ATTN: PARK SUPERINTENDENT
 STATE ROUTE 20
 PIPESTEM, WV
 25979 304-466-2804**

DATE PRINTED	TERMS OF SALE	SHIP VIA	F.O.B.	FREIGHT TERMS
05/05/2009				

BID OPENING DATE: **06/10/2009** BID OPENING TIME **01:30PM**

LINE	QUANTITY	UOP	CAT. NO.	ITEM NUMBER	UNIT PRICE	AMOUNT
<p>LITERATURE AND SPECIFICATIONS. FAILURE TO PROVIDE INFORMATION FOR ANY ALTERNATES MAY BE GROUNDS FOR REJECTION OF THE BID. THE STATE RESERVES THE RIGHT TO WAIVE MINOR IRREGULARITIES IN BIDS OR SPECIFICATIONS IN ACCORDANCE WITH SECTION 148-1-4(F) OF THE WEST VIRGINIA LEGISLATIVE RULES AND REGULATIONS.</p> <p style="text-align: center;">NOTICE</p> <p>A SIGNED BID MUST BE SUBMITTED TO:</p> <p style="text-align: center;">DEPARTMENT OF ADMINISTRATION PURCHASING DIVISION BUILDING 15 2019 WASHINGTON STREET, EAST CHARLESTON, WV 25305-0130</p> <p>THE BID SHOULD CONTAIN THIS INFORMATION ON THE FACE OF THE ENVELOPE OR THE BID MAY NOT BE CONSIDERED:</p> <p>SEALED BID</p> <p>BUYER: 44</p> <p>RFQ. NO.: DNR209112</p> <p>BID OPENING DATE: 06/10/2009</p> <p>BID OPENING TIME: 1:30 PM</p> <p>PLEASE PROVIDE A FAX NUMBER IN CASE IT IS NECESSARY</p>						

SEE REVERSE SIDE FOR TERMS AND CONDITIONS

SIGNATURE <i>Fred L Davis</i>	TELEPHONE 304-428-3000	DATE 6/9/09
TITLE owner	FEIN 41-2171922	ADDRESS CHANGES TO BE NOTED ABOVE

WHEN RESPONDING TO RFQ, INSERT NAME AND ADDRESS IN SPACE ABOVE LABELED 'VENDOR'



State of West Virginia
 Department of Administration
 Purchasing Division
 2019 Washington Street East
 Post Office Box 50130
 Charleston, WV 25305-0130

Request for Quotation

RFQ NUMBER
DNR209112

PAGE
3

ADDRESS CORRESPONDENCE TO ATTENTION OF:
FRANK WHITTAKER
304-558-2316

VENDOR

*702142549 304-428-3000
DAVIS ATHLETICS LLC
2325 LIBERTY ST

PARKERSBURG WV 26101

SHIP TO

DIVISION OF NATURAL RESOURCES
PIPESTEM STATE PARK
ATTN: PARK SUPERINTENDENT
STATE ROUTE 20
PIPESTEM, WV
25979 **304-466-2804**

DATE PRINTED 05/05/2009	TERMS OF SALE	SHIP VIA	F.O.B.	FREIGHT TERMS
BID OPENING DATE: 06/10/2009 BID OPENING TIME 01:30PM				

LINE	QUANTITY	UOP	CAT NO.	ITEM NUMBER	UNIT PRICE	AMOUNT
TO CONTACT YOU REGARDING YOUR BID: <u>304-428-3002</u>						
CONTACT PERSON (PLEASE PRINT CLEARLY): <u>Fred L. Davis</u>						
***** THIS IS THE END OF RFQ DNR209112 ***** TOTAL:						<u>61,480.23</u>

- SEE REVERSE SIDE FOR TERMS AND CONDITIONS

SIGNATURE <i>Fred L. Davis</i>	TELEPHONE 304-428-3000	DATE 6/9/09
TITLE Owner	FEIN 41-2171922	ADDRESS CHANGES TO BE NOTED ABOVE

WHEN RESPONDING TO RFQ, INSERT NAME AND ADDRESS IN SPACE ABOVE LABELED 'VENDOR'

Pipestem Resort State Park Playground Specifications

To supply playground equipment to offer play activities for children ages two (2) to twelve (12) at Pipestem Resort State Park, Pipestem, West Virginia. Playground equipment will be purchased for four separate areas in the park. Park personnel will install all playground equipment. The award may be split if it is in the best interest of the West Virginia Division of Natural Resources. All items must be F.O.B. Destination. Freight or delivery charges must be included in the price of the goods. Delivery must be made within sixty (60) days of purchase order award. All items must be delivered to Pipestem Resort State Park's maintenance area between the hours of 7:30 a.m. to 3:00 p.m., Monday through Friday.

MCKEEVER LODGE AREA PLAYGROUND

PrimeTime kid corral play structure, Model #G11823, or equal. Uprights must be a minimum of 11 gauge galvanized steel; must have a minimum of 3 mil oven cured powder coating; and must have a minimum diameter of 3½" Structure must include the following components:

- One (1) PrimeTime 2-5 crunch bar, Item #13540, or equal. Bar must be installed at upper level of play structure.
- One (1) PrimeTime nature panel, Item #12793, or equal. Panel must be installed at upper level of play structure.
- One (1) PrimeTime transfer point, Item #18255, or equal.
- One (1) PrimeTime access attachment, Item #18274, or equal.
- One (1) PrimeTime wallcano vertical wall climber, Item #18274, or equal. Climber must be a minimum of 4' in height.
- One (1) PrimeTime slate roof, Item #18674, or equal.
- One (1) PrimeTime mini arch bridge, Item #18330, or equal.
- One (1) PrimeTime clover leaf climber, item #12883, or equal. Climber must be a minimum of 4' in height.
- One (1) PrimeTime double zip slide, Item #18377, or equal. Slide must be a minimum of 4' in height.
- One (1) PrimeTime ADA gizmo panel, Item #12968, or equal. Panel must include a PrimeTime click wheel, Item #4839, or equal; PrimeTime answer wheel, Item #4840, or equal; and a PrimeTime maze wheel, Item #4841, or equal.

Pipestem Resort State Park Playground Specifications

- One (1) PrimeTime double steering wheel enclosure, Item #12814, or equal. Steering wheel must be installed at upper level.
- Two (2) PrimeTime square decks. Deck dimensions be a minimum of 45 ½" x 45 ½" and must be a minimum of 4' in height.

COTTAGE "C" AREA PLAYGROUND

PrimeTime timberline play structure, Model #G11812, or equal. Uprights must be a minimum of 11 gauge galvanized steel; must have a minimum of 3 mil oven cured powder coating; and must have a minimum diameter of 3½". Structure must include the following components:

- One (1) PrimeTime shingle roof, Item #18673, or equal.
- One (1) Primetime crawl tube, Item #12328, or equal. Tube must include spy holes and be a minimum of 4' in length.
- One (1) PrimeTime chain net, Item #12285, or equal.
- One (1) PrimeTime tree climber, Item #12008, or equal. Climber must be a minimum of 3' in height.
- Two (2) PrimeTime crunch bar, Item #12215, or equal.
- One (1) PrimeTime transfer point, Item #18254, or equal.
- One PrimeTime access attachment, Item #18273, or equal.
- One (1) PrimeTime single seat, Item "12728, or equal.
- One (1) PrimeTime bubble climber, Item #12916, or equal. Climber must be a minimum of 3' in height.
- Two (2) PrimeTime talk tube, Item#81679, or equal.
- One (1) PrimeTime rung ladder, Item #12620, or equal. Ladder must be a minimum of 3' in height.
- One (1) PrimeTime suspension bridge, Item #18335, or equal. Bridge must be a minimum length of 7' 10".

Pipestem Resort State Park Playground Specifications

- One (1) PrimeTime rumble and roll zip slide, Item #18389, or equal. Slide must be accommodate a minimum of two (2) children at the same time and must be a minimum of 3' in height.
- One (1) PrimeTime 1' barrier, Item #12441, or equal.
- One (1) PrimeTime handhold transfer, Item #12055. Or equal.
- One (1) PrimeTime decorative panel with steering wheel, Item #18376, or equal.
- One (1) PrimeTime F5 spiral slide with hood, Item #18341, or equal. Slide must be a minimum of 6' in height.
- One (1) PrimeTime shingle roof, Item #18673, or equal.
- One (1) PrimeTime wallcano vertical wall climber, Item #18364, or equal. Climber must be a minimum of 4' in height.
- One (1) PrimeTime climbing pole, Item #12630, or equal. Pole must be a minimum of 4' in height.
- Two (2) PrimeTime square decks, Item #18250, or equal. Deck dimensions must be a minimum of 45 ½ x 45 ½ and must be a minimum of 3' in height.
- One (1) PrimeTime square deck, Item #18250, or equal. Deck dimensions must be a minimum of 45 ½ x 45 ½ and must be a minimum of 4' in height.
- Two (2) PrimeTime triangle deck, Item #18203, or equal. Deck dimensions must be a minimum of 45 ½ x 45 ½ x 45 1/2 and must be a minimum of 3' in height.

CAMPGROUND AREA PLAYGROUND

PowerScope carousel play structure, Model #85113, or equal. Uprights must be a minimum of 11 gauge galvanized steel; must have a minimum of 3 mill oven cured powder coating; and must have a minimum diameter of 5". Structure must include the following components:

- One (1) PowerScope zip slide, Item #81337, or equal. Slide must be a minimum of 4' in height.

Pipestem Resort State Park Playground Specifications

- One (1) PowerScape wave climber, Item #80340, or equal. Climber must be a minimum of 3' 6" in height.
- Two (2) PowerScape talk tub, Item #81675, or equal.
- One (1) PowerScape chinning bar (one level), Item #81656, or equal.
- One (1) PowerScape overhead tree climber, Item 81529, or equal. Climber must be a minimum of 3' in height.
- One (1) PowerScape crunch bar, Item #81670, or equal.
- One (1) PowerScape overhead ladder access package, Item #80653, or equal.
- One (1) PowerScape transfer point, Item #80653, or equal.
- One (1) PowerScape access attachment, Item #80656, or equal.
- One (1) PowerScape clover climber, Item #80303, or equal. Climber must be a minimum of 3'6" in height.
- One (1) PowerScape stepped platform, Item #81202, or equal.
- One (1) PowerScape wave zip slide, Item #81339, or equal. Slide must be a minimum height of 6'.
- One (1) PowerScape zipper climber. Climber must be a minimum of 6' in height.
- Two (2) PowerScape triangle decks or equal. Deck dimensions must be a minimum of 49" x 49" x49" and must be a minimum height of 4'.
- Two (2) PowerScape triangle decks or equal. Deck dimensions must be a minimum of 49" x 49" x49" and must be a minimum of 3'6" in height.
- Two (2) PowerScape triangle decks or equal. Deck dimensions must be a minimum of 49" x 49" x49" must be a minimum of 3' in height.

MOUNTAIN CREEK LODGE PLAYGROUND

PrimeTime mix it up play structure, Model #G11813, or equal. Uprights must be a minimum of 11 gauge galvanized steel; must have a minimum of 3 mil oven cured powder coating; and must have a minimum diameter of 3 1/2". Structure must include the following components:

Pipestem Resort State Park Playground Specifications

- One (1) PrimeTime driver's enclosure panel, Item #18391, or equal.
- One (1) PrimeTime toad stool climber, Item #12239, or equal.
- One (1) PrimeTime triangle transfer platform, Item #18337, or equal.
- One (1) PrimeTime square stepped deck. Deck dimensions must be a minimum of 36" x 36".
- One (1) PrimeTime gizmo single panel, Item #12964, or equal. Panel must include a click wheel gizmo, Item #4839, or equal.
- One (1) PrimeTime nature panel, Item #12429, or equal.
- One (1) PrimeTime rumble and roll zip slide, Item #18389, or equal. Slide must be a minimum height of 3'.
- One (1) PrimeTime stepped platform, Item #18259, or equal.
- One (1) PrimeTime giant wave climber, Item #18383, or equal. Climber must be a minimum height of 5'.
- One (1) PrimeTime slate roof, Item #18672, or equal.
- One (1) PrimeTime F5 spiral slide with hood, Item #18316, or equal. Slide must be a minimum of 6' in height.
- One (1) PrimeTime rock wall climber, Item #12922, or equal. Climber must be a minimum height of 5'.
- One (1) PrimeTime rectangle deck. Deck dimensions must be a minimum of 45 ½" x 36" and be a minimum of 3' in height.
- One (1) PrimeTime square deck or equal. Deck dimension must be a minimum of 36" x 36" and must be a minimum of 3' in height.

ITEMS FOR ALL FOUR PLAYGROUNDS

Geotextile 2,250 sq. ft. roll or equal. Fabric must provide a water permeable separation between the earth and the wood fiber and at least 150 gallons per square foot per minute.

Pipestem Resort State Park Playground Specifications

Engineered wood fiber or equal @ 8" compacted depth. Material must be recently harvested and debarked; free of chemical treatments and additives; free of soil, twigs, leaves and other contaminants.

Pipestem Resort State Park Playground Specifications

All playground equipment and engineered wood fiber must meet the following requirements:

- Compliance with U.S. Consumer Product Safety Commission, Handbook for Public Playground Safety.
- Compliance with ASTM Standard F 1487.
- Compliance with Architectural and Transportation Barriers Compliance Board, Americans with Disabilities Act (ADA) Accessibility Guidelines for Buildings and Facilities; Play Areas.

Vendors must submit the following attachments:

- Complete manufacturer's parts specifications and warranties.
- Layout drawing to scale of the proposed play structure or equipment.
- ASTM and CPSC Statement of Compliance

Warranties:

- All equipment and engineered wood fiber must be guaranteed to be free of defects in workmanship and material for a minimum of one year from date of acceptance. However, if manufacturer warranty periods are longer than the required minimum one year warranty, those warranties shall apply.

All equipment requiring assembly must have pre-drilled holes and inserts. Equipment must include matching bolts for predrilled holes with inserts and any other hardware required for assembly.

Color scheme of equipment must be coordinated with Pipestem State Park. Color of items will be selected from manufacturer's standard colors.

A mandatory pre-bid conference will be held on May 19, 2009, at Pipestem State Park Headquarters at 10:00 a.m. A failure to attend the mandatory pre-bid conference will result in bid disqualification. An individual may not represent more than one firm at the pre-bid conference.

McKeever Lodge Area Playground

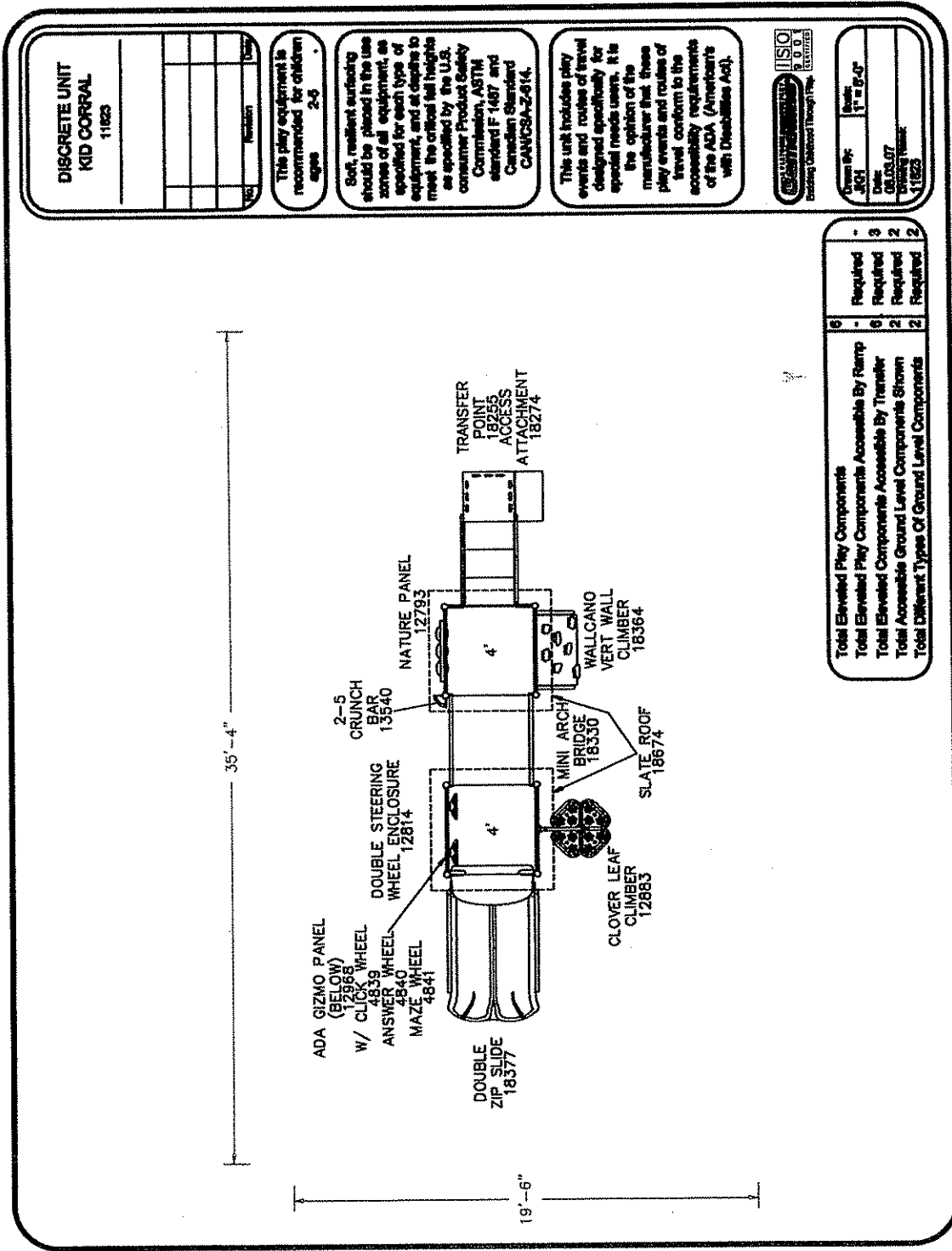

**DISCRETE UNIT
KID CORRAL**
11623

Year	Revision	Date

This play equipment is recommended for children ages 2-6

Soft, resilient surfacing should be placed in the use zones of all equipment, as specified for each type of equipment, and at heights to meet the critical fall heights as specified by the U.S. Consumer Product Safety Commission, ASTM standard F 1487 and Canadian Standard CANCOSA-Z-914.

This unit includes play events and routes of travel designed specifically for special needs users. It is the opinion of the manufacturer that these play events and routes of travel conform to the accessibility requirements of the ADA (Americans with Disabilities Act).



Drawn By:	
Scale:	1" = 8'-0"
Date:	04.03.07
Project Name:	11623

Total Elevated Play Components	6	Required
Total Elevated Play Components Accessible By Ramp	6	Required
Total Elevated Components Accessible By Transfer	2	Required
Total Accessible Ground Level Components Shown	2	Required
Total Different Types Of Ground Level Components	2	Required

Cottage "C" Area Playground

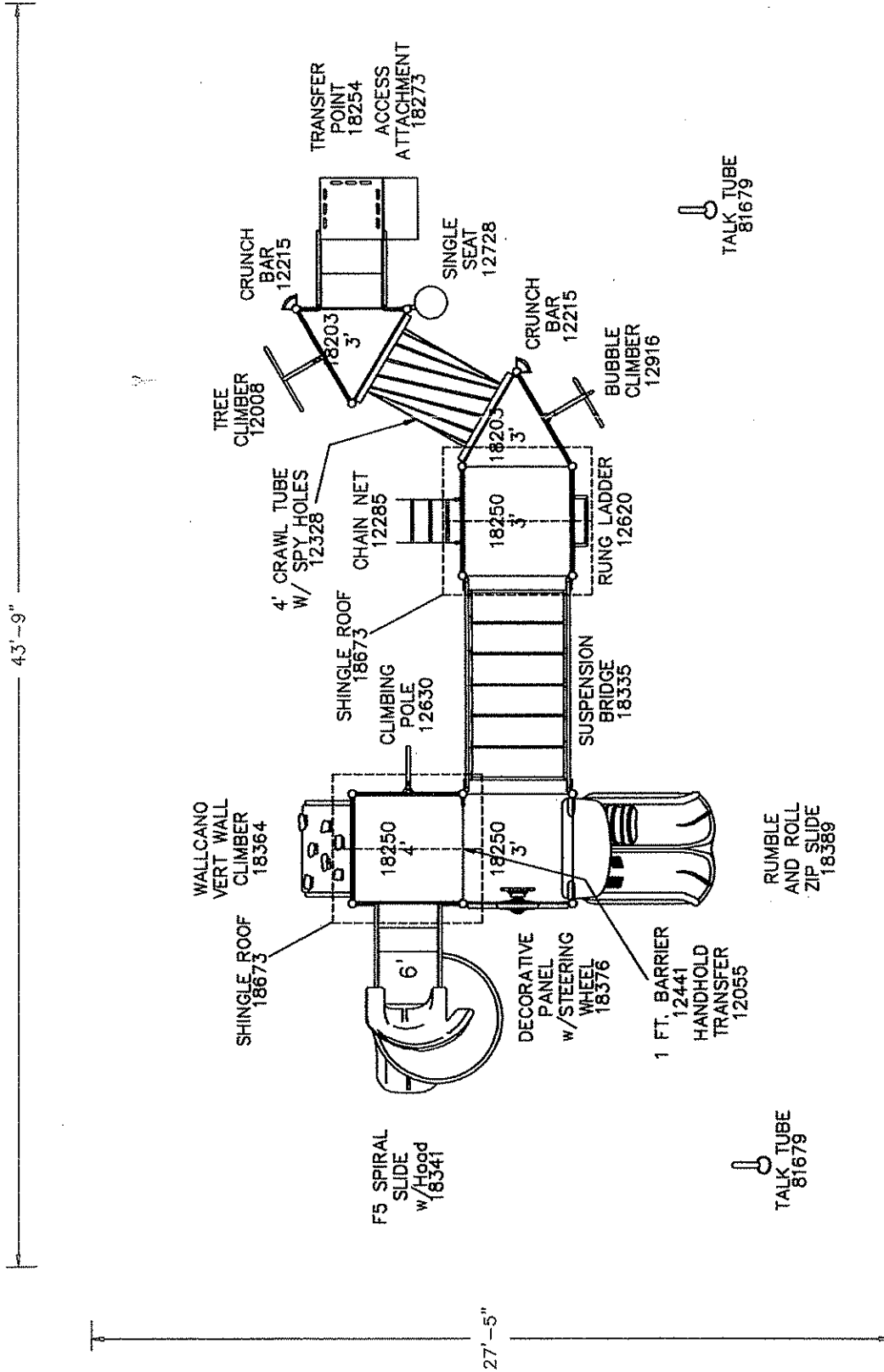

Campground Area Playground

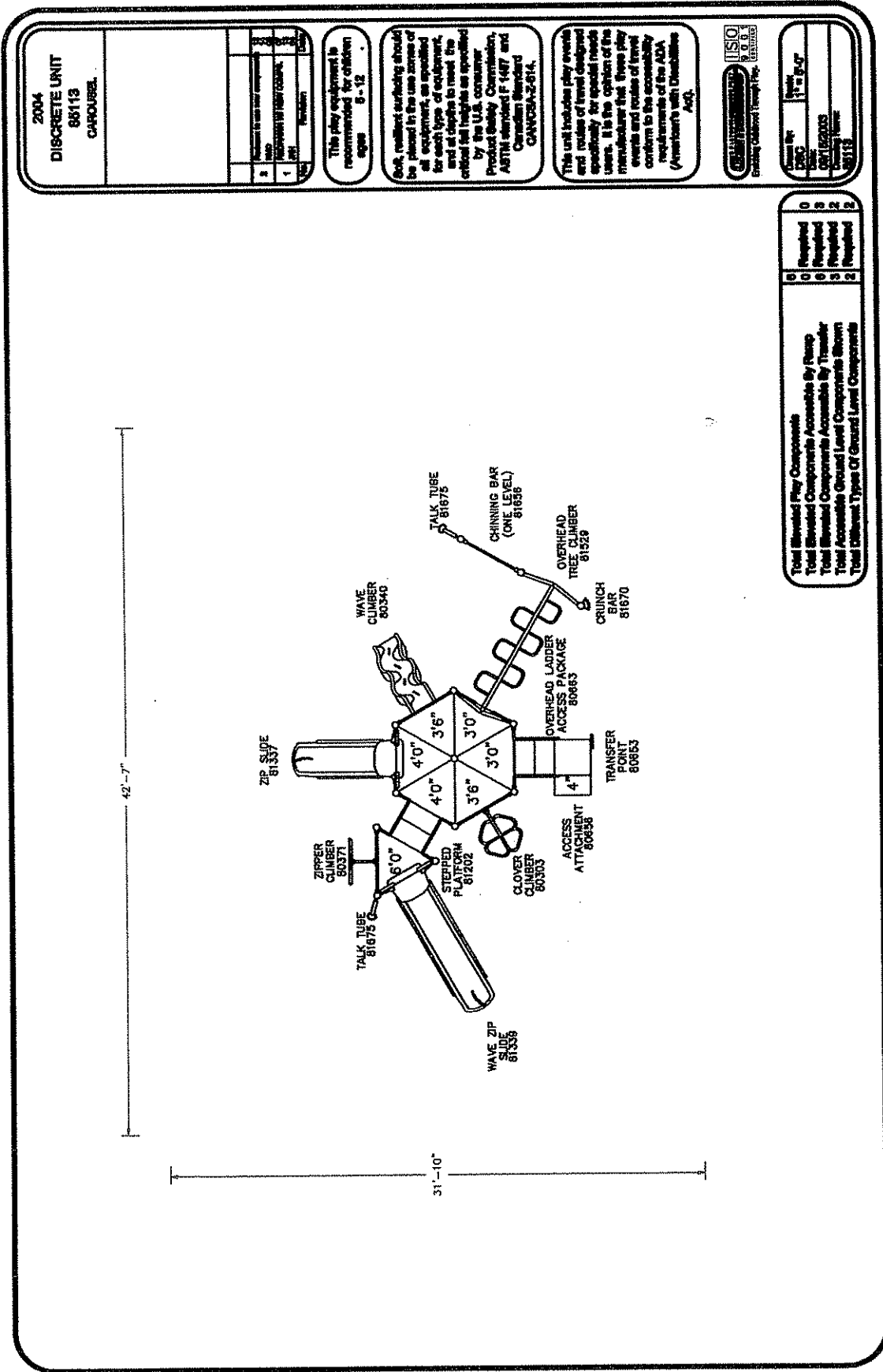

2004
DISCRETE UNIT
88113
CAROUREL

2	Manufacturer to use their own equipment	3	Manufacturer to use their own equipment
1	Manufacturer to use their own equipment	3	Manufacturer to use their own equipment

This play equipment is recommended for children ages 5-12

Soft, resilient surfacing should be placed in the use zones of all equipment, as specified for each type of equipment, and of depths to meet the critical fall heights as specified by the U.S. Consumer Product Safety Commission, ASTM standard F-1447 and Canadian Standard CAN/CSA-Z-914.

This unit includes play events and routes of travel designed specifically for special needs users. It is the opinion of the manufacturer that these play events and routes of travel conform to the accessibility requirements of the ADA (Americans with Disabilities Act).



Model No.	88113
Year	2004
Manufacturer Name	Carourel
Model Name	88113

Total Provided Components	0
Total Provided Components Accessible By Ramp	0
Total Provided Components Accessible By Transfer	0
Total Accessible Ground Level Components Shown	3
Total Unlabeled Types Of Ground Level Components	2

Mountain Creek Lodge Playground

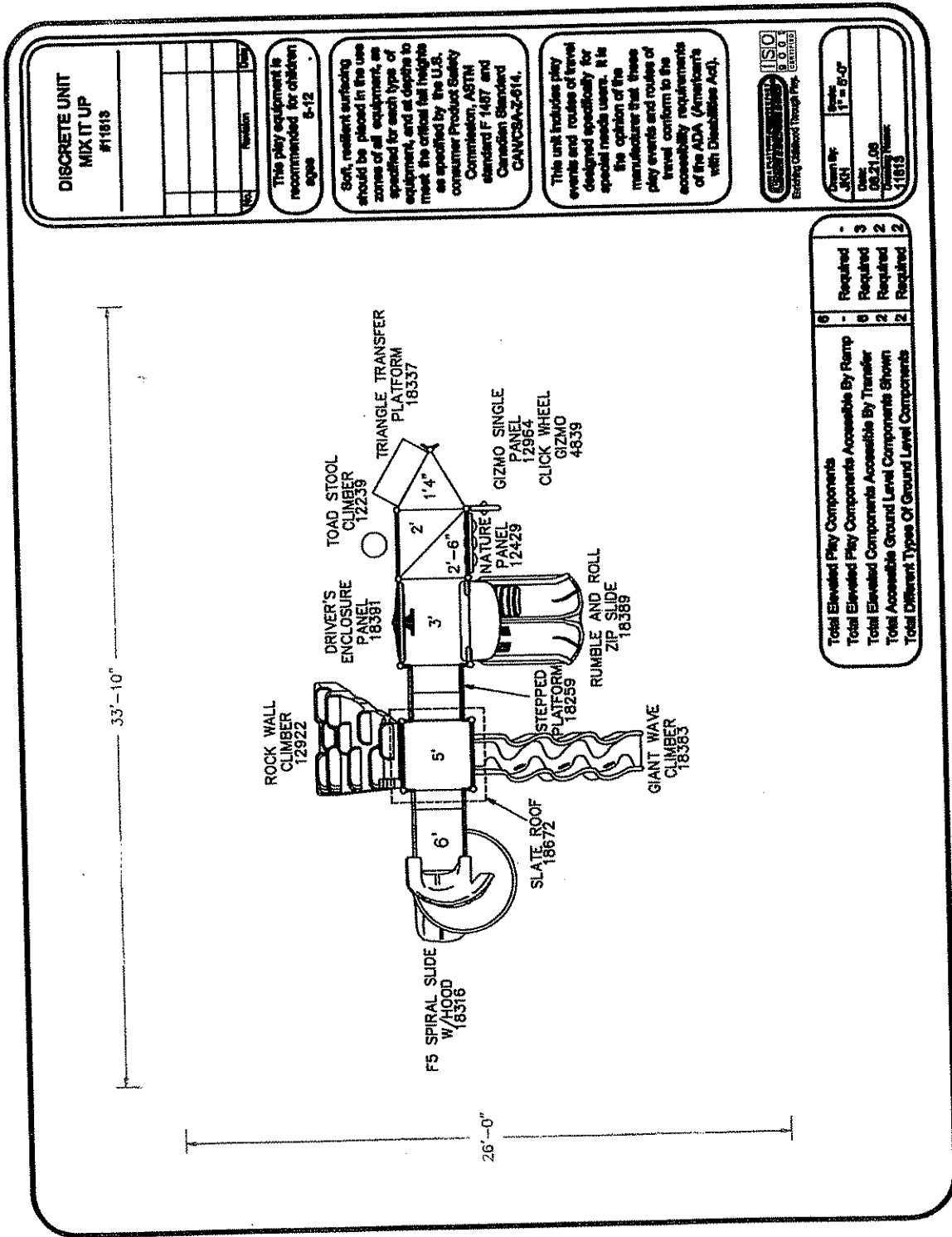

**DISCRETE UNIT
MIX IT UP
#11819**

The play equipment is recommended for children ages 5-12

Soft, resilient surfacing should be placed in the use zones of all equipment, as specified for each type of equipment, and at depths to meet the critical fall heights as specified by the U.S. Consumer Product Safety Commission, ASTM standard F 1487 and Canadian Standard CANC98A-Z-614.

This unit includes play events and routes of travel designed specifically for special needs users. It is the opinion of the manufacturer that these play events and routes of travel conform to the accessibility requirements of the ADA (Americans with Disabilities Act).



Drawn by: JCH
Date: 09.21.08
Drawing Name: #11819
Scale: 1" = 8'-0"

Pipestem Resort State Park PLAYGROUND EQUIPMENT SHEET

Please complete the below information concerning the brand(s) of equipment being bid in relation to this project. If bidding in or equal inch brands, please attach manufacturer's literature documenting that it meets the mandatory requirements stated in the specifications. Vendors should note the areas of the provided manufacturer's literature that adheres to the mandatory requirements outlined in the Request For Quotation.

Item No.	Equipment	Manufacturer	Model
1	McKeever Lodge Area Playground PrimeTime kid corral play structure, Model #G11823, or equal. Structure must include the following components:	Henderson	B300077R0
	One (1) PrimeTime 2-5 crunch bar, Item #13540, or equal.		
	One (1) PrimeTime nature panel, Item #12793, or equal.		
	One (1) PrimeTime transfer point, Item #18255, or equal.		
	One (1) PrimeTime access attachment, Item #18274, or equal.		
	One (1) PrimeTime wallcano vertical wall climber, Item #18274, or equal.		
	One (1) PrimeTime slate roof, Item #18674, or equal.		
	One (1) PrimeTime mini arch bridge, Item #18330, or equal.		
	One (1) PrimeTime clover leaf climber, item #12883, or equal.		
	One (1) PrimeTime double zip slide, Item #18377, or equal.		

Pipestem Resort State Park
PLAYGROUND EQUIPMENT SHEET

Item No.	Equipment	Manufacturer	Model
	One (1) PrimeTime ADA gizmo panel, Item #12968, or equal. Panel must include the following items: PrimeTime click wheel, Item #4839, or equal; PrimeTime answer wheel, Item #4840, or equal; and PrimeTime maze wheel, Item #4841, or equal.		↓
	One (1) PrimeTime double steering wheel enclosure, Item #12814, or equal.		
	Two (2) PrimeTime square decks.		
2	Cottage "C" Area Playground PrimeTime timberline play structure, Model #G11812, or equal. Structure must include the following components:	Henderson	B300074 RO
	One (1) PrimeTime shingle roof, Item #18673, or equal.		↓
	One (1) Primetime crawl tube, Item #12328, or equal.		
	One (1) PrimeTime chain net, Item #12285, or equal.		
	One (1) PrimeTime tree climber, Item #12008, or equal.		
	Two (2) PrimeTime crunch bar, Item #12215, or equal.		
	One (1) PrimeTime transfer point, Item #18254, or equal.		
	One (1) PrimeTime access attachment, Item #18273, or equal.		

Pipestem Resort State Park
PLAYGROUND EQUIPMENT SHEET

Item No.	Equipment	Manufacturer	Model
	One (1) PrimeTime single seat, Item "12728, or equal.		
	One (1) PrimeTime bubble climber, Item #12916, or equal.		
	Two (2) PrimeTime talk tube, Item#81679, or equal.		
	One (1) PrimeTime rung ladder, Item #12620, or equal.		
	One (1) PrimeTime suspension bridge, Item #18335, or equal.		
	One (1) PrimeTime rumble and roll zip slide, Item #18389, or equal.		
	One (1) PrimeTime 1' barrier, Item #12441, or equal.		
	One (1) PrimeTime handhold transfer, Item #12055, or equal.		
	One (1) PrimeTime decorative panel with steering wheel, Item #18376, or equal.		
	One (1) PrimeTime F5 spiral slide with hood, Item #18341, or equal.		
	One (1) PrimeTime shingle roof, Item #18673, or equal.		
	One (1) PrimeTime wallcano vertical wall climber, Item #18364, or equal.		
	One (1) PrimeTime climbing pole, Item #12630, or equal.		

Pipestem Resort State Park
PLAYGROUND EQUIPMENT SHEET

Item No.	Equipment	Manufacturer	Model
	Two (2) Primetime square decks, Item #18250, or equal.		↓
	One (1) PrimeTime square deck, Item #18250, or equal.		
	Two (2) PrimeTime triangle deck, Item #18203, or equal.		
3	Campground Area Playground PowerScape carousel play structure, Model #85113, or equal. Structure must include the following components:	Henderson	B300075R0
	One (1) PowerScape zip slide, Item #81337, or equal.		↓
	One (1) PowerScape wave climber, Item #80340, or equal.		
	Two (2) PowerScape talk tub, Item #81675, or equal.		
	One (1) PowerScape chinning bar (one level), Item #81656, or equal.		
	One (1) PowerScape overhead tree climber, Item 81529, or equal.		
	One (1) PowerScape crunch bar, Item #81670, or equal.		
	One (1) PowerScape overhead ladder access package, Item #80653, or equal.		
	One (1) PowerScape transfer point, Item #80653, or equal.		
	One (1) PowerScape access attachment, Item #80656, or equal.		

Pipestem Resort State Park
PLAYGROUND EQUIPMENT SHEET

Item No.	Equipment	Manufacturer	Model
	One (1) PowerScape clover climber, Item #80303, or equal.		
	One (1) PowerScape stepped platform, Item #81202, or equal.		
	One (1) PowerScape wave zip slide, Item #81339, or equal.		
	One (1) PowerScape zipper climber.		
	Two (2) PowerScape triangle decks or equal.		
	Two (2) PowerScape triangle decks or equal.		
	Two (2) PowerScape triangle decks or equal.		
4	Mountain Creek Lodge Playground PrimeTime mix it up play structure, Model #G11813, or equal. Structure must include the following components:	Henderson	B300076R0
	One (1) PrimeTime driver's enclosure panel, Item #18391, or equal.		
	One (1) PrimeTime toad stool climber, Item #12239, or equal.		
	One (1) PrimeTime triangle transfer platform, Item #18337, or equal.		
	One (1) PrimeTime square stepped deck.		
	One (1) PrimeTime gizmo single panel, Item #12964, or equal. Panel must include a click wheel gizmo, Item #4839, or equal.		

Pipestem Resort State Park
PLAYGROUND EQUIPMENT SHEET

Item No.	Equipment	Manufacturer	Model
	One (1) PrimeTime nature panel, Item #12429, or equal.		
	One (1) PrimeTime rumble and roll zip slide, Item #18389, or equal.		
	One (1) PrimeTime stepped platform, Item #18259, or equal.		
	One (1) PrimeTime giant wave climber, Item #18383, or equal.		
	One (1) PrimeTime slate roof, Item #18672, or equal.		
	One (1) PrimeTime F5 spiral slide with hood, Item #18316, or equal.		
	One (1) PrimeTime rock wall climber, Item #12922, or equal.		
	One (1) PrimeTime rectangle deck.		
	One (1) PrimeTime square deck or equal.		
5	Items For All Four Playgrounds geotextile 2,250 sq. ft. roll or equal.		
6	Items For All Four Playgrounds engineered wood fiber or equal @ 8" compacted depth.		



Pipestem Resort State Park Playground Equipment
PRICING SHEET

Item No.	Quantity	Description	Unit Price	Amount
1	1	McKeever Lodge Area Playground PrimeTime kid corral play structure, Model #G11823, or equal.		\$11,216
2	1	Cottage "C" Area Playground PrimeTime timberline play structure, Model #G11812, or equal.		\$18,999
3	1	Campground Area Playground PowerScape carousel play structure, Model #85113, or equal.		\$14,704.88
4	1	Mountain Creek Lodge Playground PrimeTime mix it up play structure, Model #G11813, or equal.		\$12,172.12
5	2 Rolls	Items For All Four Playgrounds geotextile 2,250 sq. ft. roll or equal.	\$500.00	\$1,000.00
6	4,183 Sq. Ft.	Items For All Four Playgrounds engineered wood fiber or equal @ 8" compacted depth.	\$.81	\$3,388.23
		TOTALS		\$61,480.23

State of West Virginia

VENDOR PREFERENCE CERTIFICATE

Certification and application* is hereby made for Preference in accordance with West Virginia Code, §5A-3-37. (Does not apply to construction contracts). West Virginia Code, §5A-3-37, provides an opportunity for qualifying vendors to request (at the time of bid) preference for their residency status. Such preference is an evaluation method only and will be applied only to the cost bid in accordance with the West Virginia Code. This certificate for application is to be used to request such preference. The Purchasing Division will make the determination of the Resident Vendor Preference, if applicable.

- 1. Application is made for 2.5% resident vendor preference for the reason checked: Bidder is an individual resident vendor and has resided continuously in West Virginia for four (4) years immediately preceding the date of this certification; or, Bidder is a partnership, association or corporation resident vendor and has maintained its headquarters or principal place of business continuously in West Virginia for four (4) years immediately preceding the date of this certification; or 80% of the ownership interest of Bidder is held by another individual, partnership, association or corporation resident vendor who has maintained its headquarters or principal place of business continuously in West Virginia for four (4) years immediately preceding the date of this certification; or, Bidder is a nonresident vendor which has an affiliate or subsidiary which employs a minimum of one hundred state residents and which has maintained its headquarters or principal place of business within West Virginia continuously for the four (4) years immediately preceding the date of this certification; or,
2. Application is made for 2.5% resident vendor preference for the reason checked: Bidder is a resident vendor who certifies that, during the life of the contract, on average at least 75% of the employees working on the project being bid are residents of West Virginia who have resided in the state continuously for the two years immediately preceding submission of this bid; or,
3. Application is made for 2.5% resident vendor preference for the reason checked: Bidder is a nonresident vendor employing a minimum of one hundred state residents or is a nonresident vendor with an affiliate or subsidiary which maintains its headquarters or principal place of business within West Virginia employing a minimum of one hundred state residents who certifies that, during the life of the contract, on average at least 75% of the employees or Bidder's affiliate's or subsidiary's employees are residents of West Virginia who have resided in the state continuously for the two years immediately preceding submission of this bid; or,
4. Application is made for 5% resident vendor preference for the reason checked: Bidder meets either the requirement of both subdivisions (1) and (2) or subdivision (1) and (3) as stated above; or,
5. Application is made for 3.5% resident vendor preference who is a veteran for the reason checked: Bidder is an individual resident vendor who is a veteran of the United States armed forces, the reserves or the National Guard and has resided in West Virginia continuously for the four years immediately preceding the date on which the bid is submitted; or,
6. Application is made for 3.5% resident vendor preference who is a veteran for the reason checked: Bidder is a resident vendor who is a veteran of the United States armed forces, the reserves or the National Guard, if, for purposes of producing or distributing the commodities or completing the project which is the subject of the vendor's bid and continuously over the entire term of the project, on average at least seventy-five percent of the vendor's employees are residents of West Virginia who have resided in the state continuously for the two immediately preceding years.

Bidder understands if the Secretary of Revenue determines that a Bidder receiving preference has failed to continue to meet the requirements for such preference, the Secretary may order the Director of Purchasing to: (a) reject the bid; or (b) assess a penalty against such Bidder in an amount not to exceed 5% of the bid amount and that such penalty will be paid to the contracting agency or deducted from any unpaid balance on the contract or purchase order.

By submission of this certificate, Bidder agrees to disclose any reasonably requested information to the Purchasing Division and authorizes the Department of Revenue to disclose to the Director of Purchasing appropriate information verifying that Bidder has paid the required business taxes, provided that such information does not contain the amounts of taxes paid nor any other information deemed by the Tax Commissioner to be confidential.

Under penalty of law for false swearing (West Virginia Code, §61-5-3), Bidder hereby certifies that this certificate is true and accurate in all respects; and that if a contract is issued to Bidder and if anything contained within this certificate changes during the term of the contract, Bidder will notify the Purchasing Division in writing immediately.

Bidder: Davis Athletics, LLC Signed: [Signature]
Date: 6/9/09 Title: Owner

*Check any combination of preference consideration(s) indicated above, which you are entitled to receive.

STATE OF WEST VIRGINIA
Purchasing Division

PURCHASING AFFIDAVIT

VENDOR OWING A DEBT TO THE STATE:

West Virginia Code §5A-3-10a provides that: No contract or renewal of any contract may be awarded by the state or any of its political subdivisions to any vendor or prospective vendor when the vendor or prospective vendor or a related party to the vendor or prospective vendor is a debtor and the debt owed is an amount greater than one thousand dollars in the aggregate.

PUBLIC IMPROVEMENT CONTRACTS & DRUG-FREE WORKPLACE ACT:

If this is a solicitation for a public improvement construction contract, the vendor, by its signature below, affirms that it has a written plan for a drug-free workplace policy in compliance with Article 1D, Chapter 21 of the *West Virginia Code*. The vendor **must** make said affirmation with its bid submission. Further, public improvement construction contract may not be awarded to a vendor who does not have a written plan for a drug-free workplace policy in compliance with Article 1D, Chapter 21 of the *West Virginia Code* and who has not submitted that plan to the appropriate contracting authority in timely fashion. For a vendor who is a subcontractor, compliance with Section 5, Article 1D, Chapter 21 of the *West Virginia Code* may take place before their work on the public improvement is begun.

ANTITRUST:

In submitting a bid to any agency for the state of West Virginia, the bidder offers and agrees that if the bid is accepted the bidder will convey, sell, assign or transfer to the state of West Virginia all rights, title and interest in and to all causes of action it may now or hereafter acquire under the antitrust laws of the United States and the state of West Virginia for price fixing and/or unreasonable restraints of trade relating to the particular commodities or services purchased or acquired by the state of West Virginia. Such assignment shall be made and become effective at the time the purchasing agency tenders the initial payment to the bidder.

I certify that this bid is made without prior understanding, agreement, or connection with any corporation, firm, limited liability company, partnership or person or entity submitting a bid for the same materials, supplies, equipment or services and is in all respects fair and without collusion or fraud. I further certify that I am authorized to sign the certification on behalf of the bidder or this bid.

LICENSING:

Vendors must be licensed and in good standing in accordance with any and all state and local laws and requirements by any state or local agency of West Virginia, including, but not limited to, the West Virginia Secretary of State's Office, the West Virginia Tax Department, West Virginia Insurance Commission, or any other state agencies or political subdivision. Furthermore, the vendor must provide all necessary releases to obtain information to enable the Director or spending unit to verify that the vendor is licensed and in good standing with the above entities.

CONFIDENTIALITY:

The vendor agrees that he or she will not disclose to anyone, directly or indirectly, any such personally identifiable information or other confidential information gained from the agency, unless the individual who is the subject of the information consents to the disclosure in writing or the disclosure is made pursuant to the agency's policies, procedures and rules. Vendor further agrees to comply with the Confidentiality Policies and Information Security Accountability Requirements, set forth in <http://www.state.wv.us/admin/purchase/privacy/noticeConfidentiality.pdf>.

Under penalty of law for false swearing (*West Virginia Code* §61-5-3), it is hereby certified that the vendor affirms and acknowledges the information in this affidavit and is in compliance with the requirements as stated.

Vendor's Name: Davis Athletics, LLC
Authorized Signature: [Signature] Date: 6/9/09



Pipestem WV State Park - Mckeever Lodge Area

Model No. B300077R0 - Davis Athletics

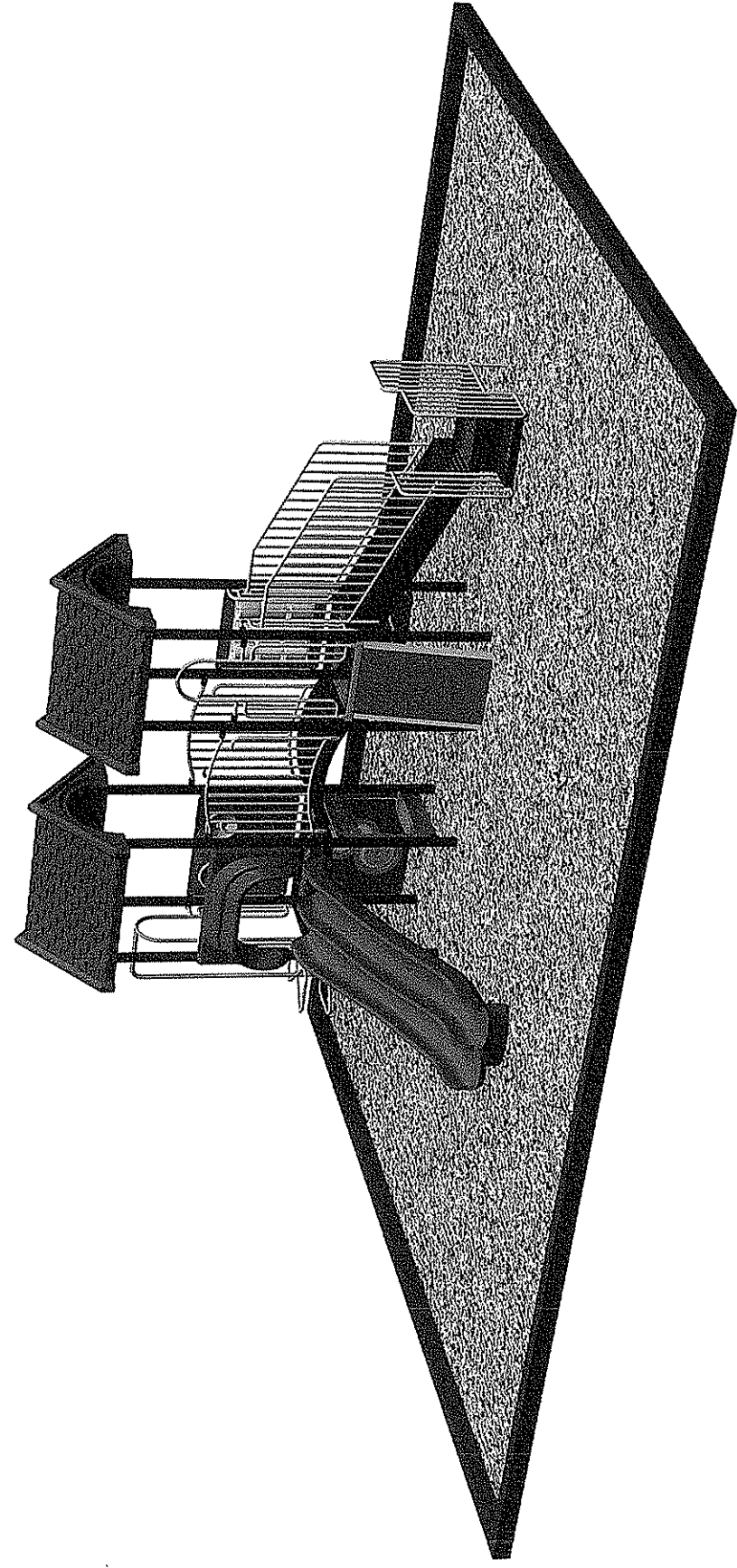

All colours shown here are approximate

© 2002 HENDERSON RECREATION. ALL RIGHTS RESERVED. HENDERSON RECREATION IS A REGISTERED TRADEMARK OF HENDERSON RECREATION. HENDERSON RECREATION IS A REGISTERED TRADEMARK OF HENDERSON RECREATION.



Pipestem WV State Park - Mckeever Lodge Area

Model No. B300077R0 - Davis Athletics

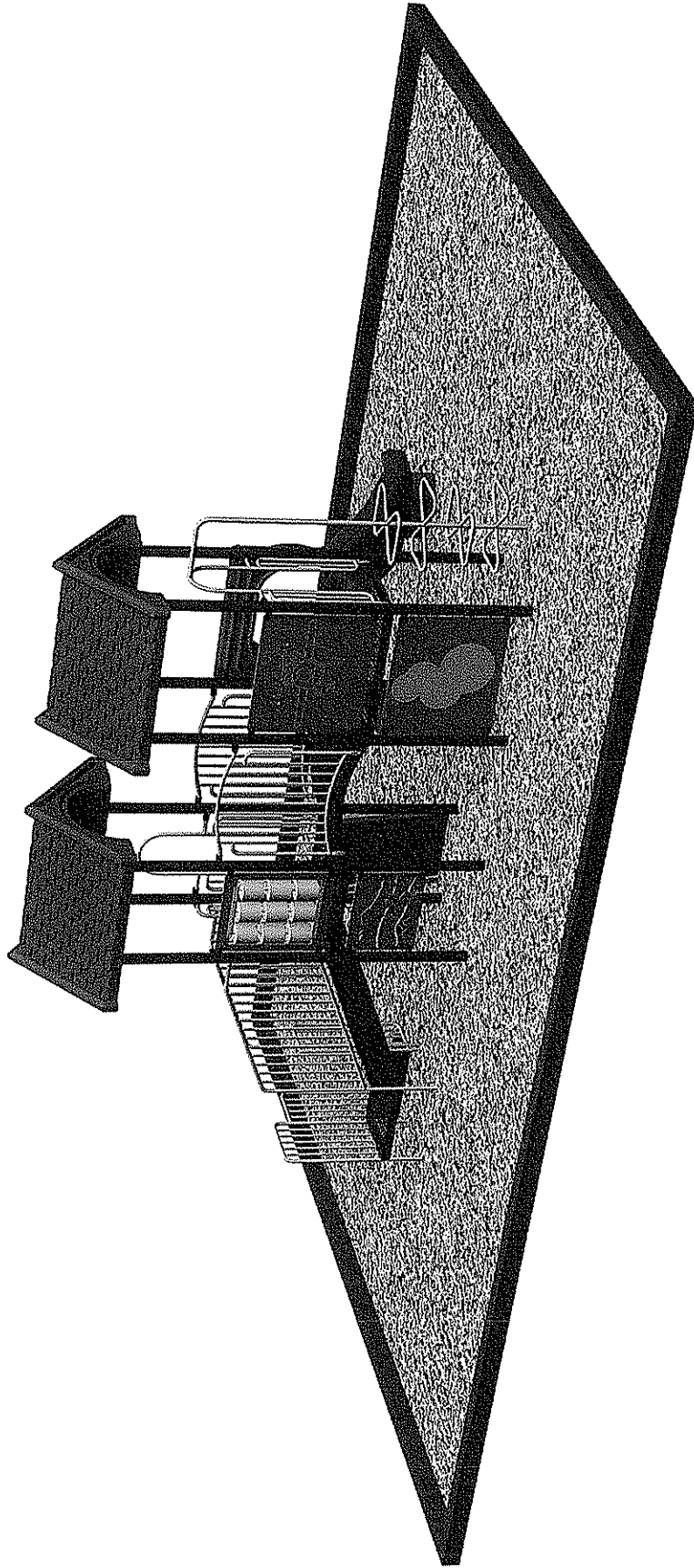

© 2008 HENDERSON RECREATION EQUIPMENT CO. ALL RIGHTS RESERVED. THIS IS A TRADE SHOW SAMPLE. FOR MORE INFORMATION, VISIT US AT WWW.HENDERSONRECREATION.COM

Model # B300077R0

Davis Athletics

Pipestem WV State Park - McKeever Lodge Area Playground

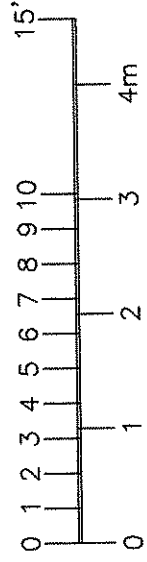

35'-0" [10.7M]

26'-0" [7.9M]

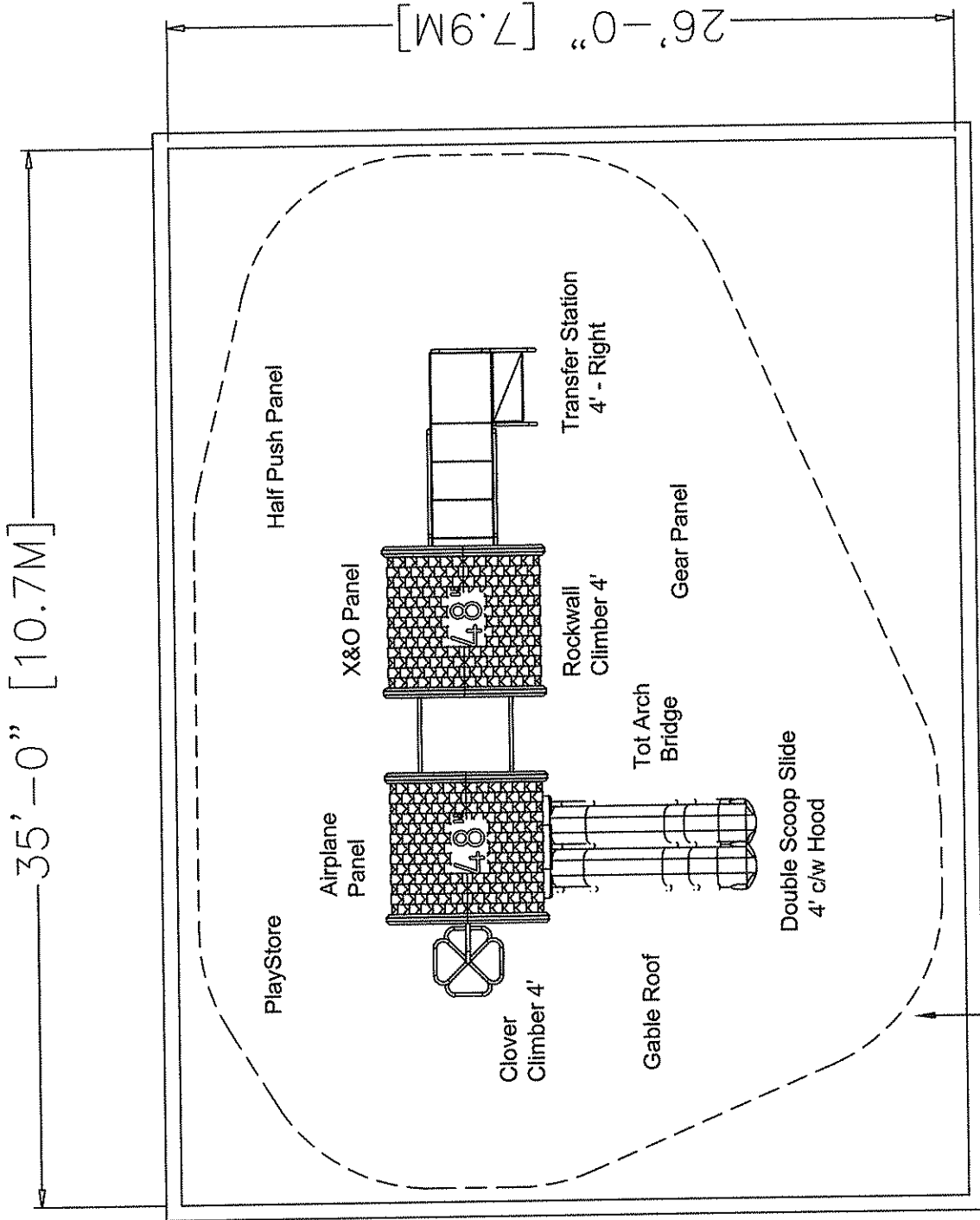

WARNING
Installation Over A Hard Surface Such As Asphalt May Result In Serious Injury Or Death From Falls.

Best User Age: 5 to 12

Accessibility: Yes

Colour:

Posts: Brown
Tan
Accent: Roto Plastic: Green
3/4 Plastic: Green/Tan
Other:

Surfacing Type: Wood Chis

Border Area: 910

Border Perimeter: 122

Installation Style:

Inground 36"

Footing Quantity: 0

Compliance:

ASTM F 1487, CPSC

Sales Rep: F.D.

Note:

All border dimensions are inside border measurements. All play structure dimensions are centre-to-centre of the posts unless otherwise specified. The locations of oil telephone, hydro, cable, water, gas, and drainage lines must be clearly marked by the customer prior to the playground installation.

All playgrounds must be installed with appropriate resilient surfacing and safety zones to meet the required guidelines of the latest CAN/CSA-Z814 (CAN) or ASTM F 1487 (USA) releases. The playground installation site must be properly prepared to Henderson Recreation's installation specifications prior to installation.

Henderson Recreation assumes the playground installation site has correct soil and digging conditions. Please notify us of any unusual soil conditions.

Henderson Recreation Equipment Limited has a commitment to continuous product development and improvement and therefore reserves the right to improve, alter or discontinue products and specifications without notice.

*Attention:
No-encroachment zones that are adjacent to but outside of the safety surface area must be free of any obstacles that would impede or block safe pedestrian traffic flow around the safety surface area. No-encroachment zones that are within the safety surface area must be free of all obstacles.

Drawn By: R.H.

Date Drawn: June 4, 2009

Revised By:

Revision Date:

Scale: See Key



Pipestem Resort WV State Park - Cottage "C" Area

Model No. B300074R0 - Davis Athletics

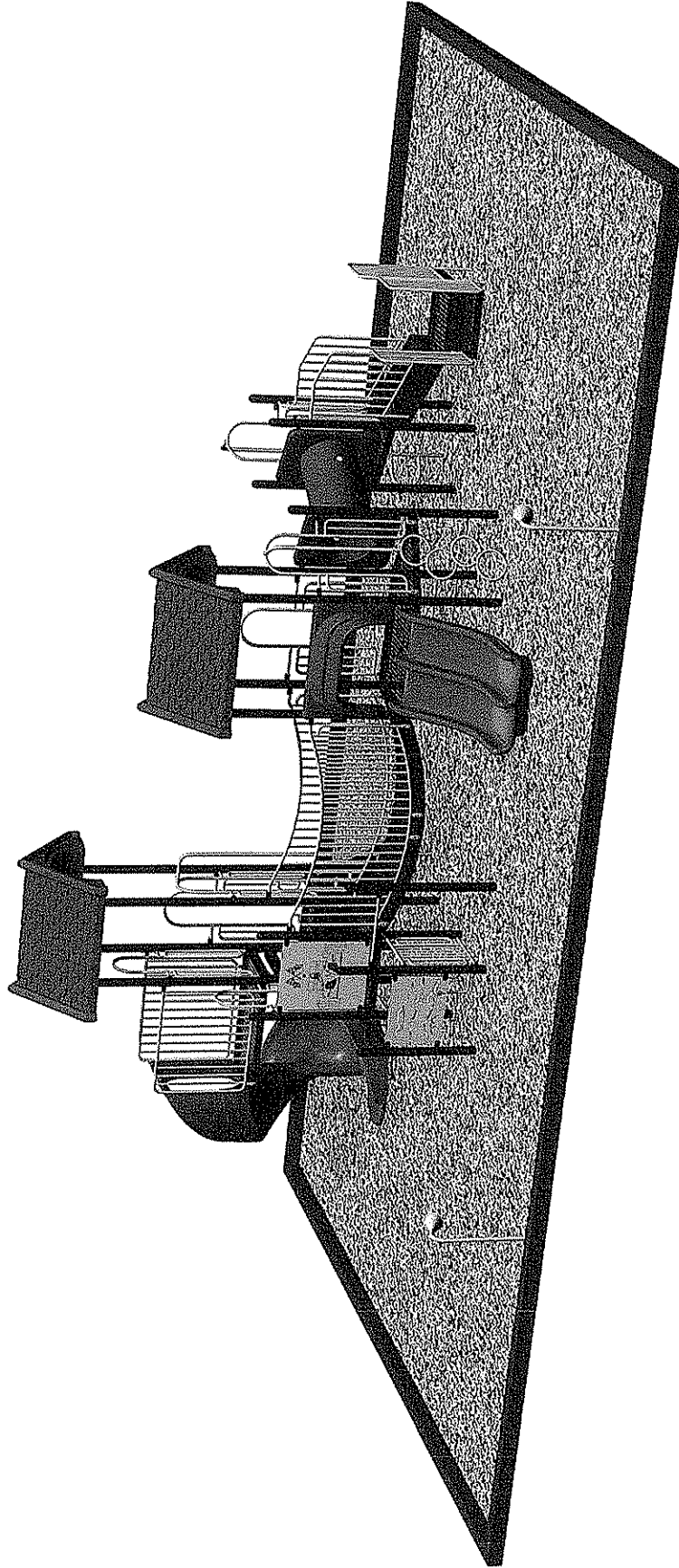

© HENDERSON RECREATION EQUIPMENT LIMITED. PO. BOX 4831 THE BRIDGEWAY, BRIDGE, ONTARIO CANADA. M3M 1S7. ALL RIGHTS RESERVED. THIS DRAWING IS NOT TO BE REPRODUCED IN ANY MANNER WITHOUT THE EXPRESS WRITTEN PERMISSION OF HENDERSON RECREATION EQUIPMENT LIMITED.



Pipestem Resort WV State Park - Cottage "C" Area

Model No. B300074R0 - Davis Athletics

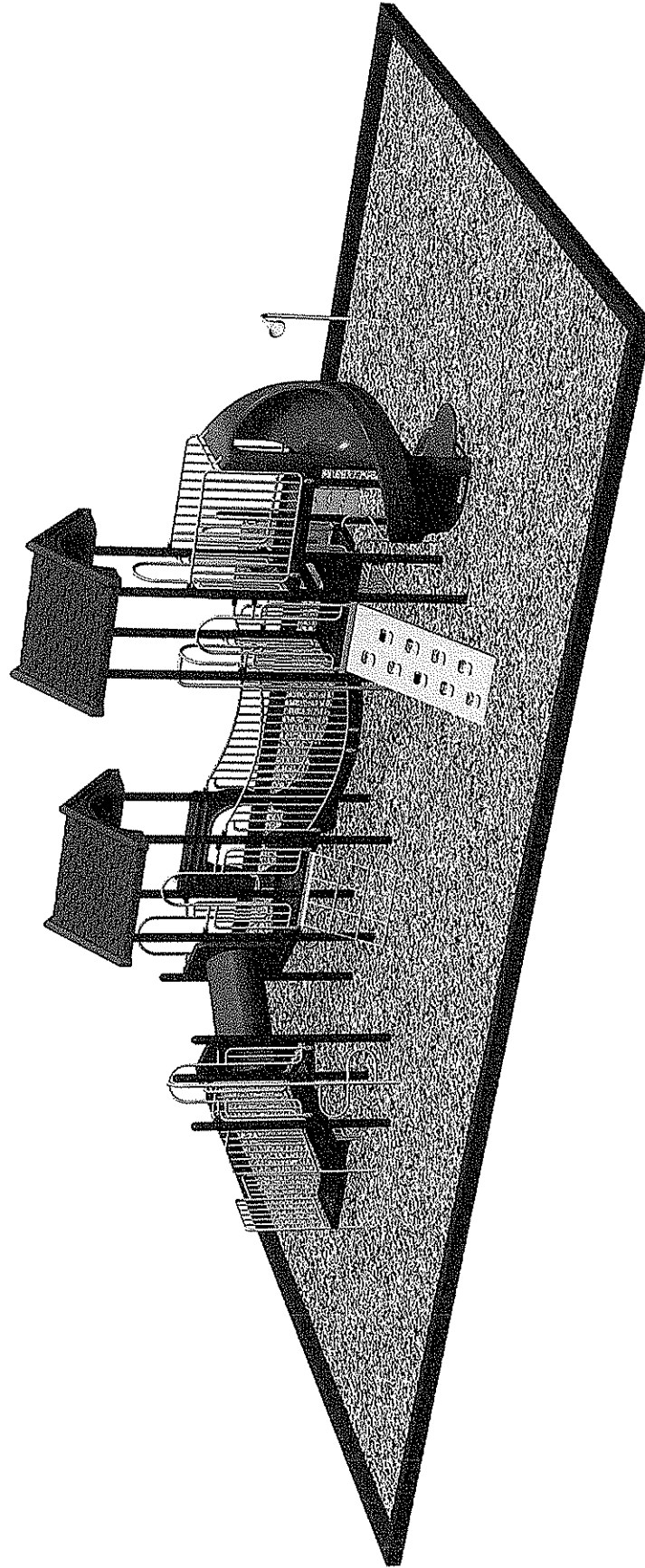

All colors shown here are approximate

HDPE Colours

Roto-Molded Plastic Colours

Powder-Coated Metal Colours

© 2000 Henderson Recreation, Inc. All rights reserved. This equipment is designed for use on safety mats. The manufacturer is not responsible for any injuries or damage caused by misuse of this equipment. The manufacturer is not responsible for any injuries or damage caused by misuse of this equipment. The manufacturer is not responsible for any injuries or damage caused by misuse of this equipment.

Model # B300074R0

Davis Athletics

Pipestem Resort WV State Park - Cottage "C" Area Playground

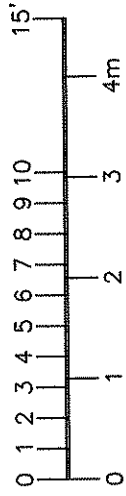

45'-6" [13.9M]

28'-0" [8.5M]

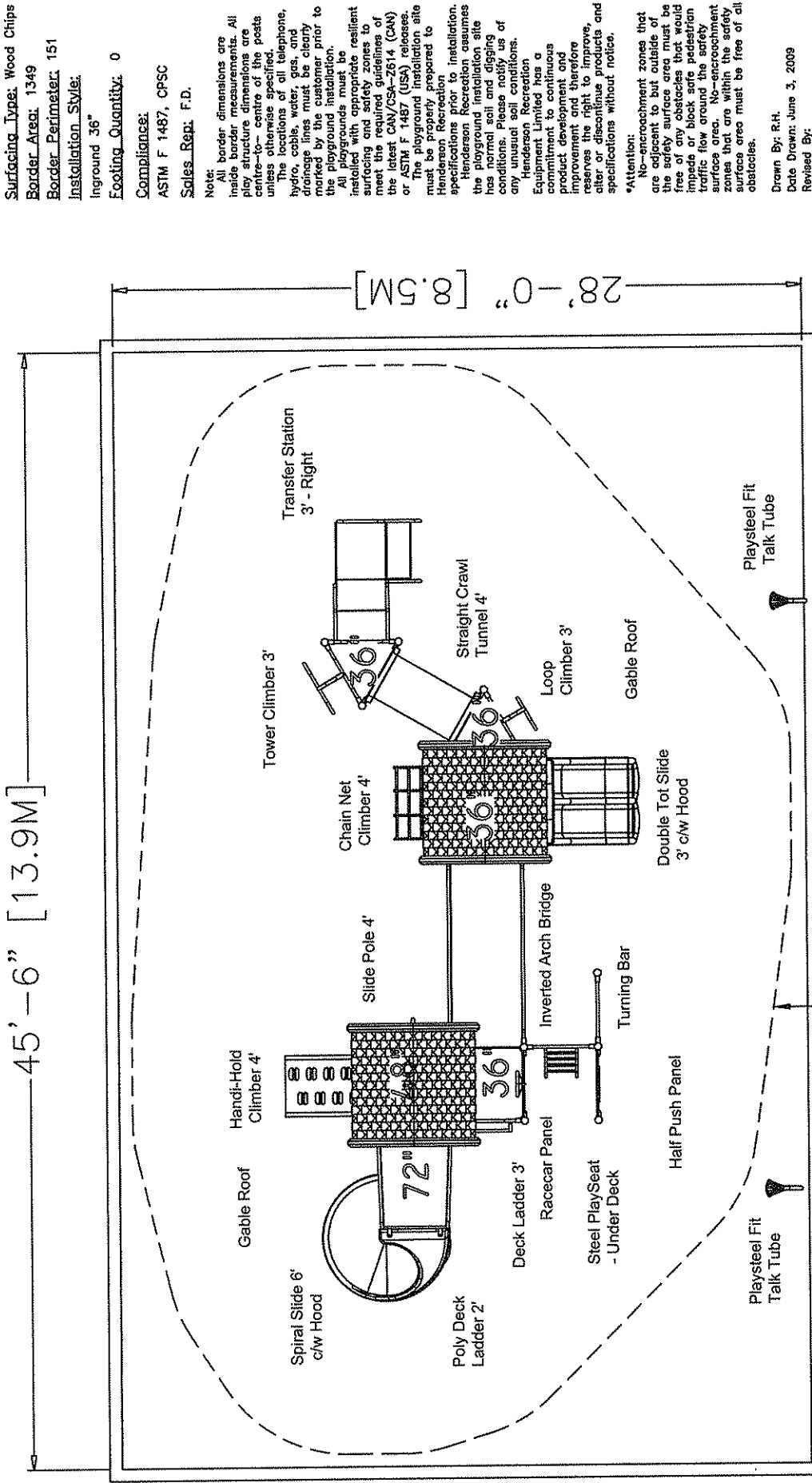

Recommended Protective Surface Zone

WARNING
Installation Over A Hard Surface Such As Concrete, Asphalt, Or Paved Areas Must Be Avoided. Front Panel Must Be Installed On A Level Surface.

Best User Age: 5 to 12

Accessibility: Yes

Colour:

Posts: Brown
 Accent: Tan
 Roto Plastic: Green
 3/4 Plastic: Tan/Green
 Other:

Surfacing Type: Wood Chips

Border Area: 1349

Border Perimeter: 151

Installation Style:

Inground 36"

Footing Quantity: 0

Compliance:

ASTM F 1487, CPSC

Sales Rept. F.D.

Note: All border dimensions are inside border measurements. All play structure dimensions are centre-to-centre of the posts unless otherwise specified.

The locations of oil telephone, hydro, cable, water, gas, and drainage lines must be clearly marked by the customer prior to the playground installation.

All playgrounds must be installed with appropriate resilient surfacing and safety zones to meet the required guidelines of the latest CAN/CSA-Z2614 (CAN) or ASTM F 1487 (USA) releases.

The playground installation site must be properly prepared to Henderson Recreation specifications prior to installation.

Henderson Recreation assumes the playground installation site has normal soil and existing conditions. Please advise us of any unusual soil conditions.

Henderson Recreation Equipment Limited has a commitment to continuous product development and improvement and therefore reserves the right to improve, alter or discontinue products and specifications without notice.

*Attention: No-encroachment zones that are adjacent to, but outside of the safety surface area must be free of any obstacles that would impede or block safe pedestrian traffic flow around the safety surface area. No-encroachment zones that are within the safety surface area must be free of all obstacles.

Date Drawn: June 3, 2009

Revised By:

Revision Date:

Scale: See Key



Pipestem WV State Park - Campground Area Playground

Model No. B300075R0 - Davis Athletics

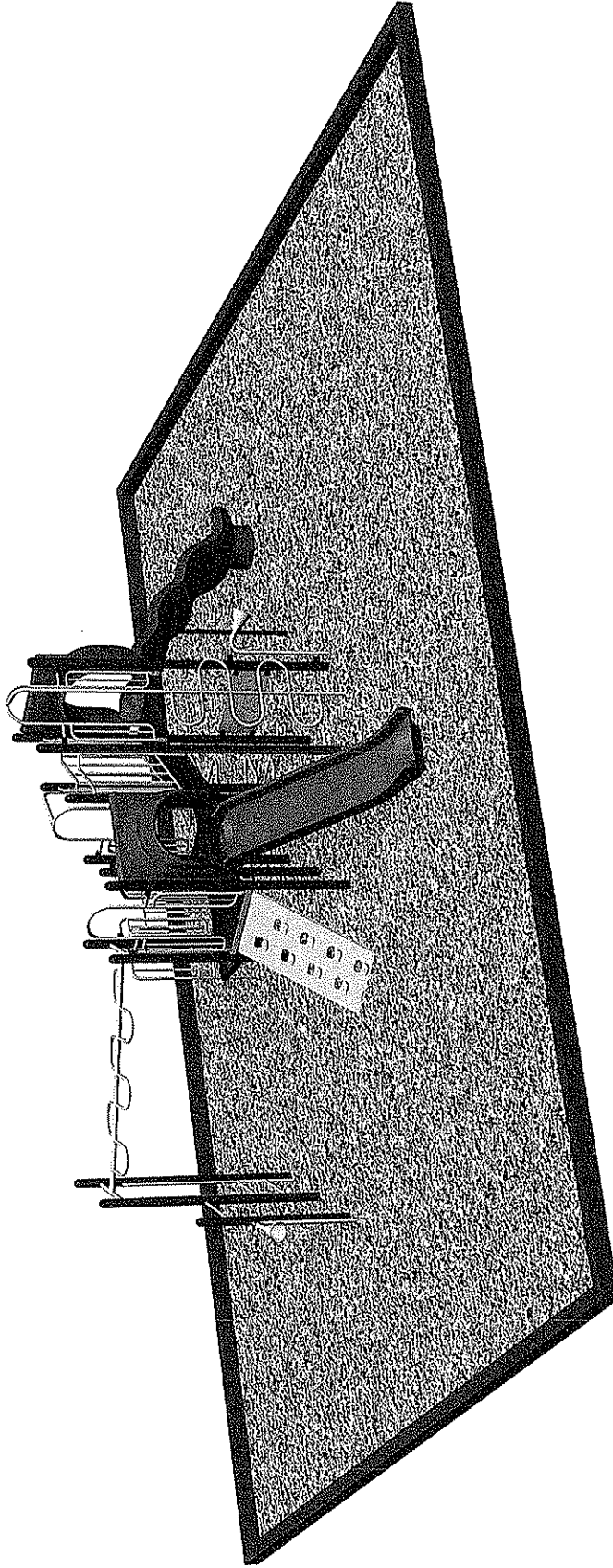

Black
Blue
Brown
Green
Orange
Purple
Red
Yellow
White
Tan
Silver
Aluminum
All colors shown here are approximate

© 2000 Playsteel, Inc. All rights reserved. Playsteel, Inc. is a registered trademark of Playsteel, Inc. All other trademarks are the property of their respective owners.



Pipestem WV State Park - Campground Area Playground

Model No. B300075R0 - Davis Athletics

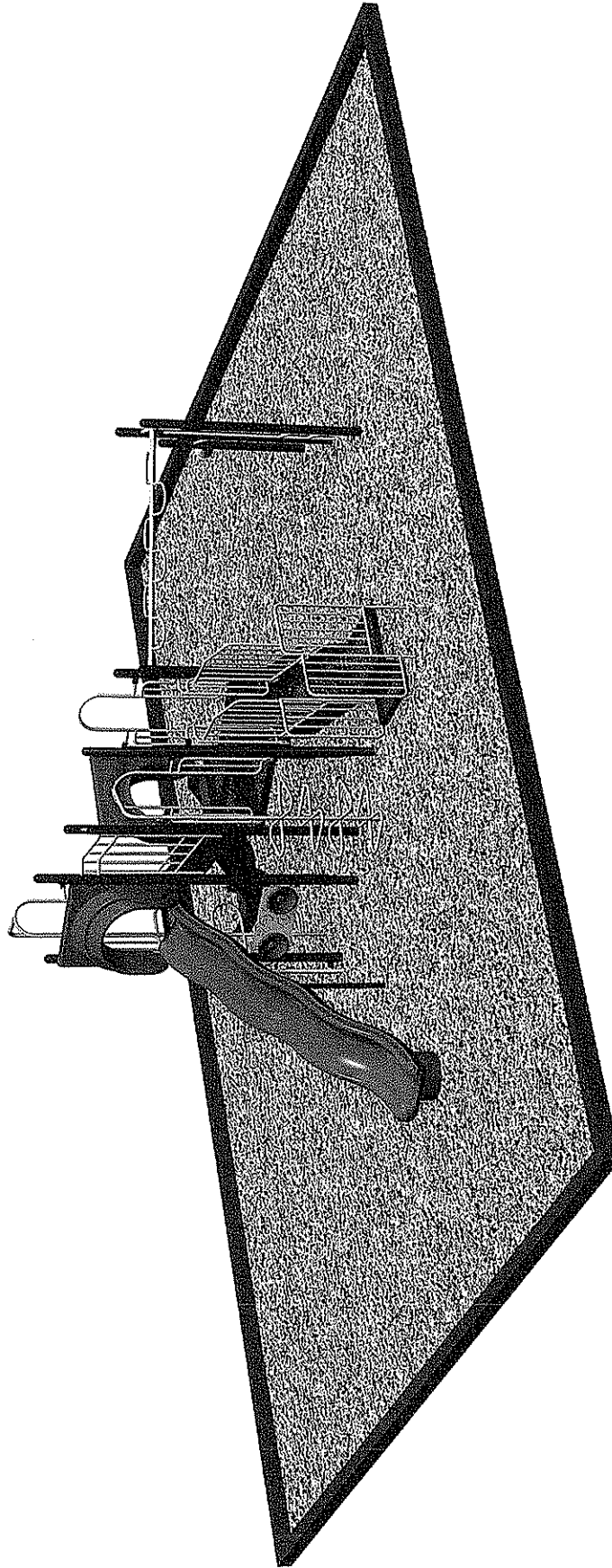

© 2008 HENDERSON RECREATION LIMITED. ALL RIGHTS RESERVED. THIS DRAWING IS NOT TO BE REPRODUCED IN ANY WAY WITHOUT EXPRESS WRITTEN PERMISSION FROM HENDERSON RECREATION.

Model # B300075R0

Davis Athletics

Pipestem WV State Park - Campground Area Playground

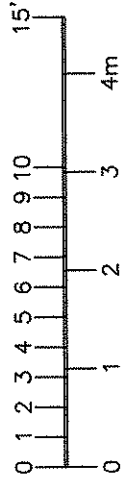

40'-6" [12.3M]

32'-0" [9.8M]

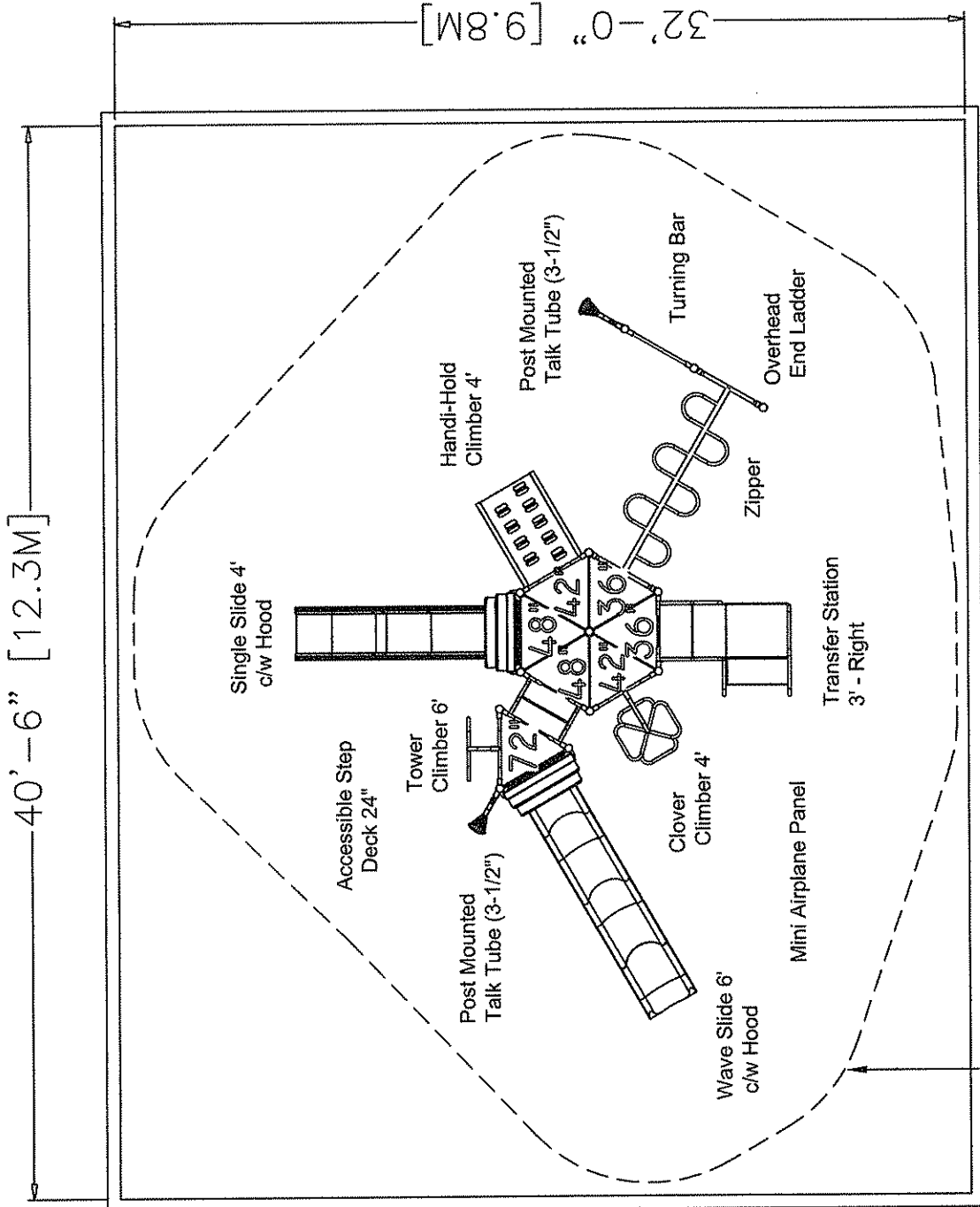

Recommended Protective Surface Zone

WARNING
 Installation Over A Hard Surface Such As Concrete May Result In Serious Injury Or Death From Falls.

Best User Age: 5 to 12

Accessibility: Yes

Colour:

Posts: Brown
 Accent: Tan
 Roto Plastic: Green
 3/4 Plastic: Green/Tan
 Other:

Surfacing Type: Wood Chips

Border Area: 1369

Border Perimeter: 149

Installation Style:

Inground 36"

Footing Quantity: 0

Compliance:

ASTM F 1487, CPSC

Sales Repr: F.D.

Note: All border dimensions are inside border measurements. All play structure dimensions are centre-to-centre of the posts unless otherwise specified.

The locations of all telephone, hydro, cable, water, gas, and drainage lines must be clearly marked by the customer prior to the playground installation.

All playgrounds must be installed with appropriate resilient surfacing and safety zones to meet the required guidelines of the latest CAN/CSA-2614 (CAN) or ASTM F 1487 (USA) releases.

The playground installation site must be properly prepared to Henderson Recreation specifications prior to installation. Henderson Recreation assumes the playground manufacturer has provided all design conditions. Please notify us of any unusual soil conditions.

Henderson Recreation Equipment Limited has a commitment to continuous product development and improvement and therefore reserves the right to improve, alter or discontinue products and specifications without notice.

*Attention: No encroachment zones that are adjacent to but outside of the safety surface area must be free of any obstacles that would impede or block safe pedestrian traffic flow around the safety surface area. No-encroachment zones that are within the safety surface area must be free of all obstacles.

Drawn By: R.H.

Date Drawn: June 3, 2009

Revised By:

Revision Date:

Scale: See Key

Henderson
 recreates equipment better



Pipestem WV State Park - Mountain Creek Lodge

Model No. B300076R0 - Davis Athletics

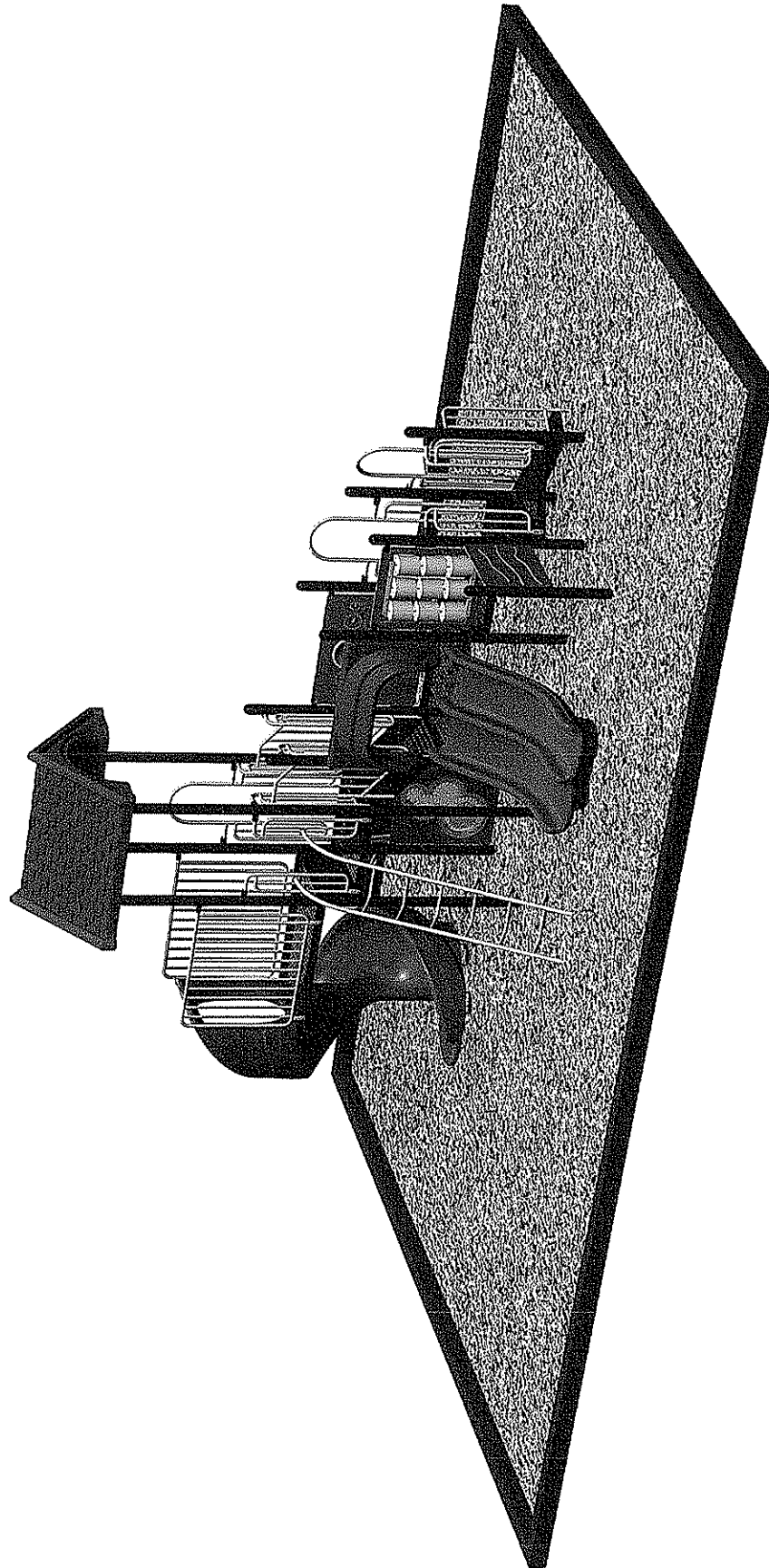

All colours shown here are approximate

Roto-Molded Plastic Colours

HDPE Colours

Powder-Coated Metal Colours

Roto-Molded Plastic Colours

HDPE Colours

Powder-Coated Metal Colours



Pipestem WV State Park - Mountain Creek Lodge

Model No. B300076R0 - Davis Athletics

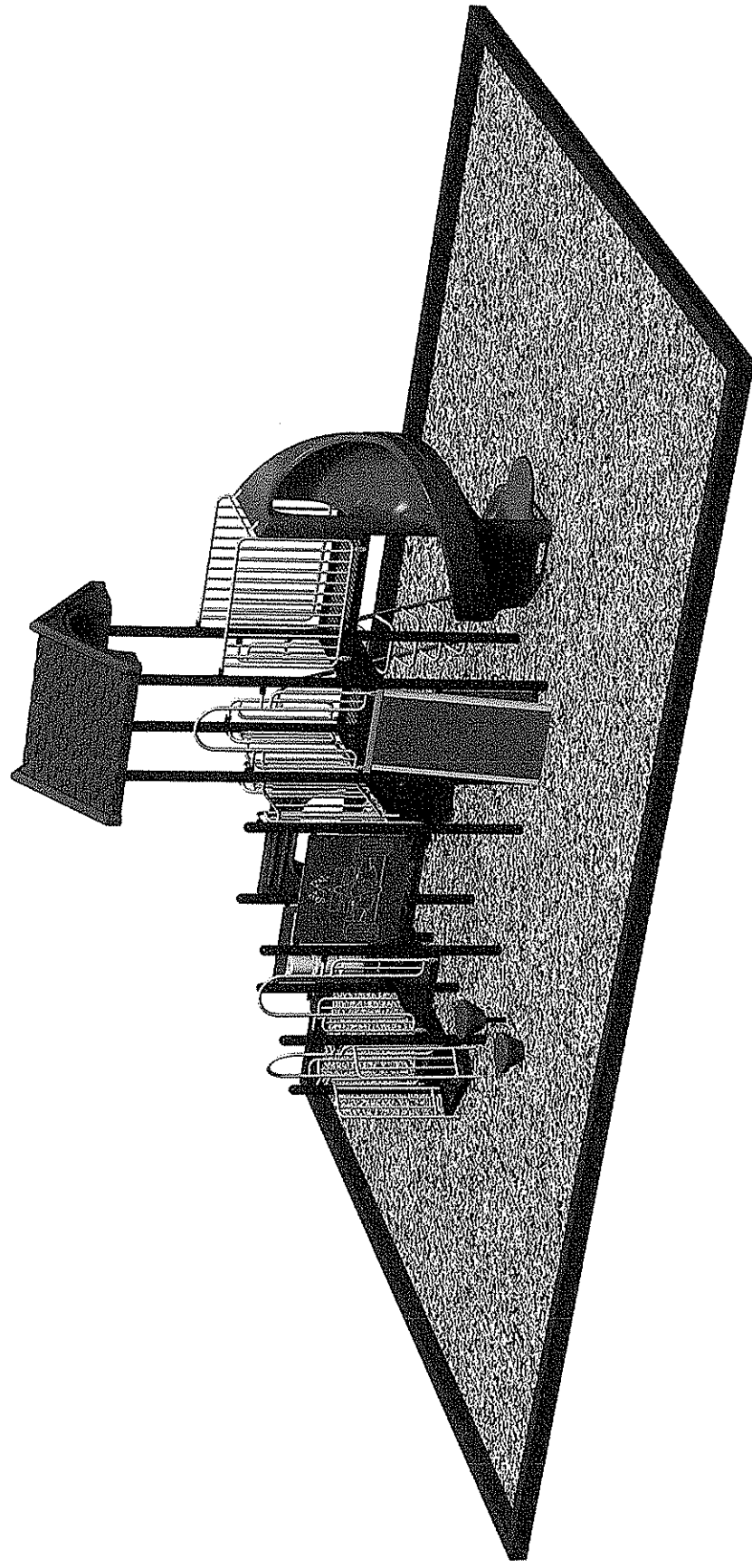

As colours shown here are approximate

HDPE Colours

Roto-Molded Plastic Colours

Powder-Coated Metal Colours

© 2005 Henderson Recreation, Inc. All rights reserved. Henderson Recreation, Inc. is a registered trademark of Henderson Recreation, Inc. All other trademarks are the property of their respective owners.

Model # B300076R0

Davis Athletics

Pipestem WV State Park - Mountain Creek Lodge Playground

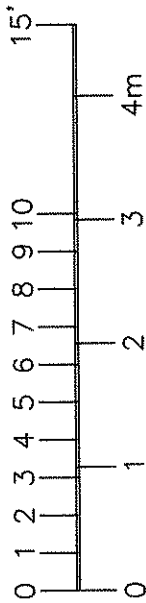

36'-0" [11.0M]

25'-0" [7.6M]

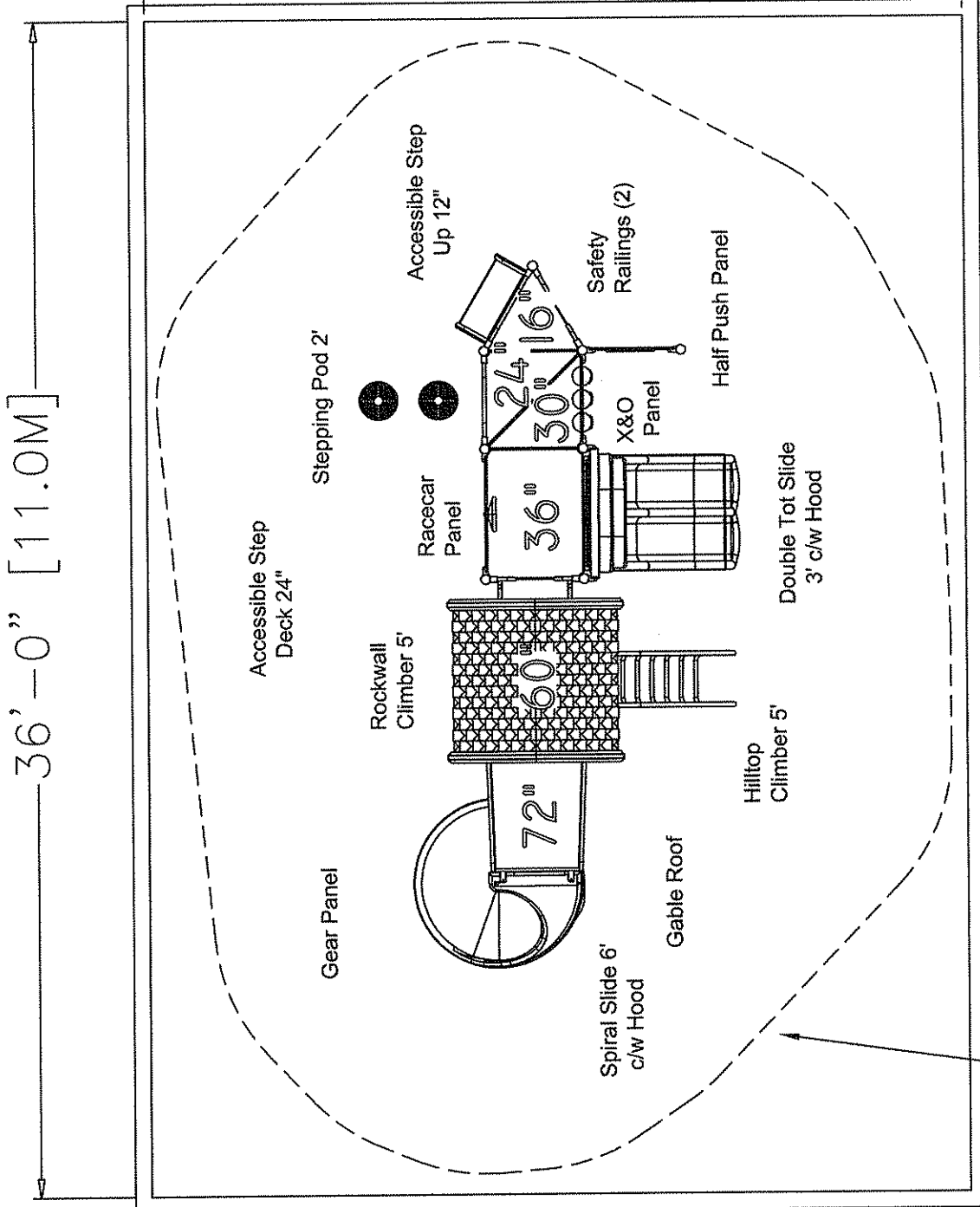

WARNING
 Installation Over A Hard Surface Such As Concrete, Asphalt, Paved Or Gravel From Fall.

Best User Age: 5 to 12

Accessibility: Yes

Colour:

Posts: Brown
 Accent: Tan
 Roto Plastic: Green
 3/4 Plastic: Green/Tan
 Other:

Surfacing Type: Wood Chips

Border Area: 962

Border Perimeter: 126

Installation Style:

Inground 36"

Footing Quantity: 0

Compliance:

ASTM F 1487, CPSC

Sales Rep: F.D.

Note:

All border dimensions are inside border measurements. All play structure dimensions are centre-to-centre of the posts unless otherwise specified. The locations of all telephone, hydro, cable, water, gas, and drainage lines must be clearly marked by the customer prior to the playground installation.

All playgrounds must be installed with appropriate resilient surfacing and safety zones to meet the required guidelines of the latest CAN/CSA-2614 (CAN) or ASTM F 1487 (USA) releases. The playground installation site must be properly prepared to Henderson Recreation specifications prior to installation.

Henderson Recreation assumes the playground installation site has normal site conditions and designs accordingly. Please notify us of any unusual soil conditions.

Henderson Recreation Equipment Limited has a commitment to continuous product development and improvement and therefore reserves the right to improve, alter or discontinue products and specifications without notice.

*Attention: No encroachment zones that are adjacent to but outside of the safety surface area must be free of any obstacles that would impede or block safe pedestrian traffic flow around the safety surface area. No-encroachment zones that are within the safety surface area must be free of all obstacles.

Drawn By: R.H.
 Date Drawn: June 3, 2009
 Revised By:
 Revision Date:
 Scale: See Key



recreable equipment limited



ASTM-F1487 Compliance Certificate

Organization:

Project:

Model:

Regarding Supply and Installation of Playground Equipment Only

This will confirm that the play ground equipment offered by Henderson Recreation is designed to comply with the most current edition of ASTM F1487, "Standard Consumer Safety Performance Specification for Playground Equipment for Public Use."

In addition, Henderson Recreation Equipment Limited will undertake to ensure that the installation of the playground equipment proposed complies with the above mentioned standard if the equipment is installed by Henderson Recreation Equipment Limited or its designated agent.

Compliance with Play Equipment Standards

Henderson Recreation Equipment Limited warrants that its products are designed and manufactured to meet or exceed the requirements of the most current edition of the ASTM F1487, "Standard Consumer Safety Performance Specification for Playground Equipment for Public Use" at the time of installation or shipment of the product.

For a period of 12 months from the date of installation or shipment, should a non-compliance to the Standard be identified that is caused by improper design, manufacturing or original installation procedure, Henderson Recreation Equipment Limited will make the necessary corrections to the equipment at its cost.

This ASTM compliance certificate does not apply when the cause of the non-compliance is the result of the following:

- Oversight by owner/operator or its designated inspectors that are not identified within the 12 month warranty period
- Oversight by third party inspectors that are not identified within the 12 month warranty period
- Failure of owner/operator to report any non-compliance to Henderson Recreation within the 12 month warranty period
- Vandalism

- Abuse
- Damage caused by natural occurrences
- Improper maintenance procedures by owner/operator or designate
- Equipment alterations that are not performed by Henderson Recreation
- Amendments or complete revisions to CAN/CSA-Z614 or ASTM F1487
- Requirements exceeding the scope of CAN/CSA-Z614 or ASTM F1487 that are mandated by various licensing, regulatory or governmental authorities
- Comments and observations offered by play space inspectors related to the design, manufacture and installation of the equipment that exceed or are outside of the scope of CAN/CSA-Z614 or ASTM F1487

Yours truly,

Gordon Henderson, President
Henderson Recreation Equipment Limited

Henderson
recreation equipment limited

Rev. 04-09

Warranty

Henderson
recreation equipment limited

Lifetime* limited warranty on bolt-through fastening system against structural failure due to corrosion or deterioration caused by defects in materials or workmanship.

20 Year* limited warranty on Mighty Shades™ steel framework against structural failure due to corrosion or deterioration caused by defects in materials or workmanship.

10 Year* limited warranty on polyethylene components, sheet plastic, decks and Geodes™ against structural failure due to corrosion or deterioration caused by defects in materials or workmanship.

10 Year* limited warranty on Mighty Shades™ fabric against deterioration, rot, or faulty workmanship, including seam failure.

Lifetime* limited warranty on steel support posts against structural failure due to corrosion or deterioration caused by defects in materials or workmanship.

15 Year* limited warranty on steel rails, loops and rungs against structural failure due to corrosion or deterioration caused by defects in materials or workmanship.

10 Year* limited warranty on Southern Yellow Pine pressure-treated wood products against structural failure due to insect infestation and fungal decay caused by defects in materials and workmanship.

5 Year* Limited Warranty on all Site Amenities, including all benches, tables, litter receptacles and bike racks, against structural failure due to corrosion or deterioration caused by defects in materials and workmanship.

One Year* General Warranty

Limited 1-Year Warranty on all other moving parts, swing seats, and any other materials not covered above. Henderson Recreation will repair or replace all parts of the product or equipment found to be defective free of charge. Warranty periods start at date of invoice.

* Items Not Covered in the above Warranties

Product or equipment that is not installed in conformity with the layout plan and/or installation instructions provided by Henderson Recreation; product or equipment that has not been maintained and inspected in accordance with Henderson Recreation's instructions; product or equipment that has been subjected to misuse, negligence or accident; product or equipment that has been subjected to addition, modification, alteration, repair, or part substitution by persons other than Henderson Recreation or Henderson Recreation's designees. Labour or damages resulting from vandalism, abnormal use, incorrect installation, and lack of routine maintenance are not covered by the above warranties. These warranties do not include any or all of the following cosmetic issues: scratches, dents, marring, fading of colours, discoloration, normal wear and tear and natural fading, and the weathering of wood, including but not limited to raised grain, splitting, checking, twisting, warping, shrinkage, swelling or any other physical property of the wood. The terms, "rot" and "fungal decay," as used in this warranty mean attack by wood-

destroying fungi that disintegrate the wood cell walls, but exclude surface mold and mildew fungi associated with the "weathering of wood." "Weathering" of wood is not decay, fungal decay, or rot of any type or definition. The above warranties are exclusive and in lieu of all other warranties, whether expressed or implied, including, but not limited to any warranty of merchantability or fitness for a particular purpose. Further, no representation, oral or written, of any representative of Henderson Recreation may be substituted for the above described limited warranties. To the extent permitted by law, Henderson Recreation shall not be liable for, direct, indirect, special, incidental, or consequential damages which are expressly excluded from the above warranties.

Any freight costs associated with the warranty claim, any costs for dismantling the defective part in order to replace it, and any installation costs associated with the replacement part(s) are not considered part of this warranty and will not be paid by Henderson Recreation. This warranty excludes liability other than that expressly stated, including but not limited to any incidental or consequential damages.

Warranty Claims

To be valid, all warranty claims must be submitted in writing promptly following discovery of the defect(s) and within the specified warranty period. Henderson Recreation requires that all warranty claims be

accompanied by a copy of the original invoice and photograph(s) clearly identifying the defect(s) in question.

Product Replacement

Henderson Recreation Equipment Limited has a commitment to continuous product development and improvement and therefore reserves the right to make approved substitutions in design or specifications.

Loss or Damage in Transit

Henderson Recreation cannot be held responsible for the loss or damage of products by common carriers. Please check the bill of lading carefully to ensure your product is in good order prior to signing it. After the product departs our plants(s), we are no longer responsible for any loss, damage, or shortage.

Maintenance

The demand for safety requires regular inspection of playground structures for signs of wear and tear. All necessary repairs should be completed promptly by a qualified repair person. For more information on the regulations concerning playground equipment, installation, maintenance, and protective surfacing, please refer to your local and national safety standards.

PlaySteel Fit/Max Playsystems: Unit-Built, 3.5" Modular & 5" Modular

Product and Coating Specifications

Steel Component Specifications:

All round steel tubing shall be in-line galvanized and tested in compliance with ASTM-A500, ASTM-A-135, or ASTM-A-513 standards.

Unit-Built System: Square Posts – 4.00" x 4.00" x 0.125" wall (11 ga.), *in-line galvanized steel*
Mechanical Properties: 50,000 psi yield / 55,000 psi tensile strength

3.5" Modular System: Round Posts – 3.50" O.D. x 0.095" wall (13 ga.), *in-line galvanized steel*
Mechanical Properties: 45,000 psi yield / 48,000 psi tensile strength

5" Modular System: Round Posts – 5.00" O.D. x 0.120" wall (11 ga.), *in-line galvanized steel*
Mechanical Properties: 45,000 psi yield / 48,000 psi tensile strength

Post Caps and Modular System Clamps – Aluminum Alloy SAE 413

Typical Handrails – 1.3125" O.D. x 11 ga. or 14 ga. wall and 1" x 0.75" Oval x 15 ga., In-line galvanized steel

Stringer Channels – 4" x 1.5" x 3/16" G40.21 iron

Platforms and Deck Surfaces – 12 ga. perforated sheet steel

Plastic Component Specifications:

Polyethylene for rotationally molded or sheet components shall have ultraviolet (UV) stabilizers and colour pigment molded in. This material shall be tested in compliance with ASTM Test Method D1248, Type 2, Class A, and Federal Specifications LP-390C, Type 1, Class M, Grade 2, Category 3, and rotationally molded items shall have an average wall thickness of .25" (6.4mm).

Fastener Specifications:

All bolts, nuts, screws, and washers shall be either zinc plated, di-chromate washed, or stainless steel. All necessary fasteners shall be supplied.

Polyester Powder Coated Items:

Steel shall receive premium galvanic rust inhibiting treatments and an electrostatically applied polyester powder coating. The coating shall be cured at temperatures between 400 degrees F (204 degrees C) and 450 degrees F (232 degrees C). The polyester powder shall be tested in compliance with ASTM standards: D522 Flexibility Mandrel Test, D2794 Impact Resistance Test, B117 Salt Spray Resistance Test, D2247 Humidity Resistance Test, D3363 Pencil Hardness Test, D3359 Method B Crosshatch Adhesion Test. Such testing demonstrates the superior weatherability characteristics of polyester powder coating over epoxy or hybrid paints.

Steel items without In-Line Galvanized Coatings shall receive a Zinc-Rich Epoxy Primer prior to Polyester Powder Coating. This only applies to a relatively small range of components that utilize non-standard tubing sizes.

Plastisol Coatings:

Thickness shall average approximately 1/8" (3.2 mm) providing a safe, resilient surface

Polyethylene Coatings:

Thickness shall average approximately 1/16" (2 mm) providing more durability than plastisol yet still retaining resilience.

BELAIR has endeavoured to ensure that all specifications and representations of products provided in this catalogue were accurate at time of publication. BELAIR reserves the right to improve, alter or discontinue any item without notice. As a result, some items may not be exactly as depicted or specified.

DIN Compliance: Note: All BELAIR playground related products are designed to be installed over a protective surface.

CSA Compliance:

Products manufactured after 2003 are designed to comply with CSA Standard CAN/CSA-Z614-03, Children's Playspaces and Equipment.

All components are designed to comply with CSA Requirements and are periodically tested for Structural Integrity as per CSA Sections: 9.2 Stability, 9.3 Load Testing Criteria, 9.4 Strength of Swing Components and Structures, 9.5 Vertical Loads, 9.6.2 Accidental Concentrated Load (Lateral Force of 2000 Newtons), and 9.6.3 Lateral Surge Load.

This standard is published by the CSA (Canadian Standards Association). A copy of this Standard can be ordered by calling (416) 747-4044, or by contacting the nearest CSA office.

ASTM Testing Parameters

STRUCTURAL SQUARE AND RECTANGULAR TUBING ASTM A-500 GRADES B AND C

ASTM A-500 is a cold formed electric weld product. Advantages include material strength, ability to resist stress from any direction, and ease of connection to other structural shapes.

CHEMICAL COMPOSITION CHECK ANALYSIS		
Max. Percent	ASTM A-500 Grade B	ASTM A-500 Grade C
Carbon	0.30	0.27
Phosphorus	0.045	0.045
Sulphur	0.045	0.045

WORKABILITY AND WELDABILITY

Can be subjected to most of the usual fabricating operations. Its ductility is good, bends well, flattens, cuts, punches, flares, and flanges easily. Can also be welded by commonly employed techniques and practices.

MECHANICAL PROPERTIES		
	ASTM	
	A-500 Grade B	Grade C
Tensile Strength, min, psi	58,000	62,000
Yield Strength, min, psi	46,000	50,000
Elongation in 2 inch, min, percent	23	21

STRUCTURAL SQUARE AND RECTANGULAR TUBING MAXIMUM OUTSIDE CORNER RADII TOLERANCES

10.6 Radius of Corners—For square or rectangular structural tubing, the radius of any outside corner of the section shall not exceed three times the specified wall thickness.

OUTSIDE DIMENSIONS AND WALL THICKNESS SQUARE AND RECTANGULAR		
Largest Outside Dimension Across Flats, Inches	Tolerance for Outside Dimensions Including Convexity or Concavity	Wall Thickness Tolerance
1 to 2-1/2 incl.	Plus or minus 0.020"	Plus or minus 10% Exclusive of weld area
Over 2-1/2 to 3-1/2 incl.	Plus or minus 0.025"	Plus or minus 10% Exclusive of weld area
Over 3-1/2 to 5-1/2 incl	Plus or minus 0.030"	Plus or minus 10% Exclusive of weld area
Over 5-1/2	Plus or minus 1%	Plus or minus 10% Exclusive of weld area

NOTE: The allowable variation in wall thickness does not apply at corners.

A500 ROUND OD AND WALL TOLERANCES

1.900" and smaller OD: ±1/2%
 2.000 and larger OD: ±3/4%
WALL THICKNESS ±10%

TOLERANCES			
SQUARENESS OF SIDES			
Adjacent sides of structural hollows may deviate from 90° by plus or minus two degrees maximum.			
VARIATIONS FROM EXACT STRAIGHTNESS			
Permissible Variations, In. (Includes Camber and Sweep) 1/8" x 5		Number of Feet of Total Length 5	
MAXIMUM TWIST			
Longer Outside Dimensions, Inches		Maximum Twist Per 3 Feet of Length, Inches	
1 to 1-1/2 incl.		0.050	
Over 1-1/2 to 2-1/2 incl.		0.062	
Over 2-1/2 to 4 incl.		0.075	
Over 4 to 6 incl.		0.087	
Over 6 to 8 incl.		0.100	
Over 8		0.112	
Twist is measured by holding down the edge of one end of a square or rectangular structural hollow on a surface plate with the bottom side of the tube parallel to the surface plate and noting the height that either corner on the opposite end of the bottom side is above the surface plate.			
PERMISSIBLE VARIATION — MILL LENGTHS			
To 22' incl.		Over 22' to 44' incl.	
Over	Under	Over	Under
1/2"	1/4"	3/4"	1/4"

Cut lengths of stock material can normally be held within 1/8 in. or closer if desired.