

**MODULAR PLAYGROUND**  
PREPARED FOR  
**PINNACLE ROCK**  
**STATE PARK**  
**BLUEFIELD, WV**  
**MAY 7<sup>TH</sup>, 2009**

**CONTENTS**

**PROPOSAL**  
**2-D DRAWING**  
**3-D RENDERING**  
**COMPLIANCE INFORMATION**  
**ISO 9001 CERTIFICATION**  
**GAMETIME INSURANCE POLICY**  
**GAMETIME WARRANTY**  
**ORDER CHECK SHEET**  
**COLOR SELECTION SHEET**  
**GAMETIME COLOR OPTIONS**

**CUNNINGHAM ASSOCIATES, INC**  
**P.O. BOX 240981**  
**CHARLOTTE, NC 28224**  
**1-800-438-2780**

RECEIVED  
2009 MAY 11 PM 12:33  
WV PURCHASING  
DIVISION



State of West Virginia  
 Department of Administration  
 Purchasing Division  
 2019 Washington Street East  
 Post Office Box 50130  
 Charleston, WV 25305-0130

# Request for Quotation

RFQ NUMBER  
**DNR209111**

PAGE  
**1**

ADDRESS CORRESPONDENCE TO ATTENTION OF  
**FRANK WHITTAKER  
 304-558-2316**

**\*709033753 800-438-2780**  
**CUNNINGHAM ASSOCIATES INC**  
**PO BOX 240981**  
  
**CHARLOTTE NC 28224**

**DIVISION OF NATURAL RESOURCES**  
**PINNACLE ROCK STATE PARK**  
**ATTN: PARK SUPERINTENDENT**  
**POST OFFICE BOX 704**  
**BLUEFIELD, WV**  
**24701 589-5307**

DATE PRINTED <b>04/14/2009</b>	TERMS OF SALE	SHIP VIA	F.O.B.	FREIGHT TERMS
BID OPENING DATE: <b>05/12/2009</b>		BID OPENING TIME <b>01:30PM</b>		

LINE	QUANTITY	UOP	CAT NO.	ITEM NUMBER	UNIT PRICE	AMOUNT
<b>J001</b>	<b>1</b>	<b>LS</b>		<b>650-38</b>	<b>\$38,851.90</b>	
<p><b>PLAYGROUND EQUIPMENT PINNACLE ROCK STATE PARK</b></p> <p><b>REQUEST FOR QUOTATION (RFQ)</b></p> <p>THE WEST VIRGINIA STATE PURCHASING DIVISION FOR THE AGENCY, THE WEST VIRGINIA DIVISION OF NATURAL RESOURCES, IS SOLICITING BIDS TO PROVIDE ALL MATERIAL AND INSTALLATION OF PLAYGROUND EQUIPMENT FOR PINNACLE ROCK STATE PARK LOCATED IN BRAMWELL, WEST VIRGINIA PER THE ATTACHED SPECIFICATIONS.</p> <p>A MANDATORY PRE-BID MEETING WILL BE HELD ON APRIL 29, 2009 AT 11:00 AM AT THE PARK HEADQUARTERS IN BRAMWELL, WEST VIRGINIA. ALL VENDORS WISHING TO SUBMIT A BID FOR THIS PROJECT MUST ATTEND THIS MEETING. NO ONE PERSON MAY REPRESENT MORE THAN ONE VENDOR.</p> <p>TECHNICAL QUESTIONS CONCERNING THIS PROJECT MUST BE SUBMITTED TO FRANK WHITTAKER IN THE WEST VIRGINIA STATE PURCHASING DIVISION VIA FAX AT 304-558-4115 OR VIA EMAIL AT FRANK.M.WHITTAKER@WV.GOV. DEADLINE FOR ALL TECHNICAL QUESTIONS IS MAY 5, 2009 AT THE CLOSE OF BUSINESS. ALL TECHNICAL QUESTIONS RECEIVED, IF ANY, WILL BE ANSWERED BY ADDENDUM AFTER THE DEADLINE HAS LAPSED.</p> <p>QUESTIONS CONCERNING THE PROCESS BY WHICH A VENDOR MAY SUBMIT A BID TO THE STATE OF WEST VIRGINIA ARE</p>						

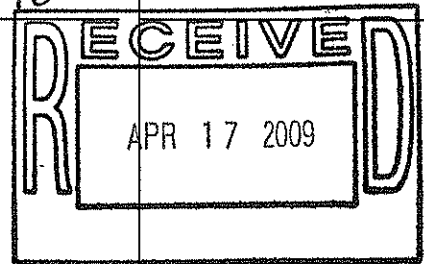

SEE REVERSE SIDE FOR TERMS AND CONDITIONS

SIGNATURE <i>[Signature]</i>	TELEPHONE <b>800-438-2780</b>	DATE <b>5/7/09</b>
---------------------------------	----------------------------------	-----------------------

TITLE <b>Project Manager</b>	FEIN <b>54-0887979</b>	ADDRESS CHANGES TO BE NOTED ABOVE
---------------------------------	---------------------------	-----------------------------------

WHEN RESPONDING TO RFQ, INSERT NAME AND ADDRESS IN SPACE ABOVE LABELED 'VENDOR'



State of West Virginia  
 Department of Administration  
 Purchasing Division  
 2019 Washington Street East  
 Post Office Box 50130  
 Charleston, WV 25305-0130

# Request for Quotation

RFQ NUMBER  
**DNR209111**

PAGE  
**2**

ADDRESS CORRESPONDENCE TO ATTENTION OF  
**FRANK WHITTAKER  
 304-558-2316**

**\*709033753 800-438-2780**  
**CUNNINGHAM ASSOCIATES INC**  
**PO BOX 240981**  
**CHARLOTTE NC 28224**

**DIVISION OF NATURAL RESOURCES**  
**PINNACLE ROCK STATE PARK**  
**ATTN: PARK SUPERINTENDENT**  
**POST OFFICE BOX 704**  
**BLUEFIELD, WV**  
**24701 589-5307**

DATE PRINTED <b>04/14/2009</b>	TERMS OF SALE	SHIP VIA	F.O.B.	FREIGHT TERMS
-----------------------------------	---------------	----------	--------	---------------

BID OPENING DATE: **05/12/2009** BID OPENING TIME **01:30PM**

LINE	QUANTITY	UOP	CAT NO	ITEM NUMBER	UNIT PRICE	AMOUNT
<p>NOT CONSIDERED TO BE TECHNICAL QUESTIONS AND MAY BE SUBMITTED AT ANY TIME PRIOR TO THE BID OPENING AND IN ANY FORMAT.</p> <p>EXHIBIT 5</p> <p>WEST VIRGINIA CODE 21-1D-5 PROVIDES THAT: ANY SOLICITATION FOR A PUBLIC IMPROVEMENT CONSTRUCTION CONTRACT REQUIRES EACH VENDOR THAT SUBMITS A BID FOR THE WORK TO SUBMIT AT THE SAME TIME AN AFFIDAVIT OF COMPLIANCE WITH THE BID. THE ENCLOSED DRUG-FREE WORKPLACE AFFIDAVIT MUST BE SIGNED AND SUBMITTED WITH THE BID AS EVIDENCE OF THE VENDOR'S COMPLIANCE WITH THE PROVISIONS OF ARTICLE 1D, CHAPTER 21 OF THE WEST VIRGINIA CODE. FAILURE TO SUBMIT THE SIGNED DRUG-FREE WORKPLACE AFFIDAVIT WITH THE BID SHALL RESULT IN DISQUALIFICATION OF SUCH BID.</p> <p>NOTICE TO PROCEED: THIS CONTRACT IS TO BE PERFORMED WITHIN 90 CALENDAR DAYS AFTER THE NOTICE TO PROCEED IS RECEIVED. UNLESS OTHERWISE SPECIFIED, THE FULLY EXECUTED PURCHASE ORDER WILL BE CONSIDERED NOTICE TO PROCEED.</p> <p>CANCELLATION: THE DIRECTOR OF PURCHASING RESERVES THE RIGHT TO CANCEL THIS CONTRACT IMMEDIATELY UPON WRITTEN NOTICE TO THE VENDOR IF THE MATERIALS OR WORKMANSHIP SUPPLIED ARE OF AN INFERIOR QUALITY OR DO NOT CONFORM WITH THE SPECIFICATIONS OF THE BID AND CONTRACT HERE IN.</p> <p>WAGE RATES: THE CONTRACTOR OR SUBCONTRACTOR SHALL PAY THE HIGHER OF THE U.S. DEPARTMENT OF LABOR MINIMUM WAGE RATES AS ESTABLISHED FOR POCAHONTAS COUNTY, PURSUANT TO WEST VIRGINIA CODE 21-5A, ET, SEQ. (PREVAILING WAGE RATES APPLY TO THIS PROJECT)</p>						

SEE REVERSE SIDE FOR TERMS AND CONDITIONS

SIGNATURE <i>[Signature]</i>	TELEPHONE <b>800-438-2780</b>	DATE <b>5/4/09</b>
---------------------------------	----------------------------------	-----------------------

TITLE <b>Project Manager</b>	FEIN <b>54-0583979</b>	ADDRESS CHANGES TO BE NOTED ABOVE
---------------------------------	---------------------------	-----------------------------------

WHEN RESPONDING TO RFQ, INSERT NAME AND ADDRESS IN SPACE ABOVE LABELED 'VENDOR'



State of West Virginia  
 Department of Administration  
 Purchasing Division  
 2019 Washington Street East  
 Post Office Box 50130  
 Charleston, WV 25305-0130

# Request for Quotation

RFO NUMBER  
**DNR209111**

PAGE  
**3**

ADDRESS CORRESPONDENCE TO ATTENTION OF  
**FRANK WHITTAKER  
 304-558-2316**

**\*709033753 800-438-2780**  
**CUNNINGHAM ASSOCIATES INC**  
**PO BOX 240981**  
**CHARLOTTE NC 28224**

**S H I P T O**  
 DIVISION OF NATURAL RESOURCES  
 PINNACLE ROCK STATE PARK  
 ATTN: PARK SUPERINTENDENT  
 POST OFFICE BOX 704  
 BLUEFIELD, WV  
 24701 589-5307

DATE PRINTED <b>04/14/2009</b>	TERMS OF SALE	SHIP VIA	F.O.B.	FREIGHT TERMS
BID OPENING DATE: <b>05/12/2009</b>		BID OPENING TIME <b>01:30PM</b>		

LINE	QUANTITY	UOP	CAT NO.	ITEM NUMBER	UNIT PRICE	AMOUNT
<p>ARBITRATION: ANY REFERENCES MADE TO ARBITRATION OR INTEREST FOR PAYMENTS DUE (EXCEPT FOR ANY INTEREST REQUIRED BY STATE LAW) CONTAINED IN THIS CONTRACT OR IN ANY AMERICAN INSTITUTE OF ARCHITECTS DOCUMENTS PERTAINING TO THIS CONTRACT ARE HEREBY DELETED.</p> <p>WORKERS' COMPENSATION: VENDOR IS REQUIRED TO PROVIDE A CERTIFICATE FROM WORKERS' COMPENSATION, IF SUCCESSFUL, FOR THE LIFE OF THE CONTRACT.</p> <p>ALL OF THE ITEMS CHECKED BELOW WILL BE A REQUIREMENT OF THIS CONTRACT:</p> <p>(XX) INSURANCE: SUCCESSFUL VENDOR SHALL FURNISH PROOF OF COMMERCIAL GENERAL LIABILITY INSURANCE PRIOR TO ISSUANCE OF CONTRACT. UNLESS OTHERWISE SPECIFIED IN THE BID DOCUMENTS, THE MINIMUM AMOUNT OF INSURANCE COVERAGE REQUIRED IS \$250,000.</p> <p>( ) BUILDERS RISK INSURANCE: SUCCESSFUL VENDOR SHALL FURNISH PROOF OF BUILDERS RISK - ALL RISK INSURANCE IN AN AMOUNT EQUAL TO 100% OF THE AMOUNT OF THE CONTRACT.</p> <p>(XX) BONDS: FIVE PERCENT (5%) OF THE TOTAL AMOUNT OF THE BID PAYABLE TO THE STATE OF WEST VIRGINIA, SHALL BE SUBMITTED WITH EACH BID AS A BID BOND. THE SUCCESSFUL BIDDER SHALL ALSO FURNISH A PERFORMANCE BOND AND LABOR/MATERIAL BOND FOR 100% OF THE AMOUNT OF THE CONTRACT. BONDS MAY BE PROVIDED IN THE FORM OF A CERTIFIED CHECK, IRREVOCABLE LETTER OF CREDIT, OR BOND FURNISHED BY A SOLVENT SURETY COMPANY AUTHORIZED TO DO BUSINESS IN THE STATE OF WEST VIRGINIA. A LETTER OF CREDIT SUBMITTED IN LIEU OF A BOND WILL ONLY BE ALLOWED FOR PROJECTS UNDER \$100,000. PERSONAL OR BUSINESS CHECKS ARE NOT ACCEPTABLE IN LIEU OF THE 5% BID BOND, PERFORMANCE BOND, OR LABOR AND MATERIAL BOND.</p>						

SEE REVERSE SIDE FOR TERMS AND CONDITIONS

SIGNATURE TELEPHONE **800-438-2780** DATE **5/7/09**

TITLE **Project Manager** FEIN **54-0882979** ADDRESS CHANGES TO BE NOTED ABOVE

WHEN RESPONDING TO RFQ, INSERT NAME AND ADDRESS IN SPACE ABOVE LABELED 'VENDOR'



State of West Virginia  
 Department of Administration  
 Purchasing Division  
 2019 Washington Street East  
 Post Office Box 50130  
 Charleston, WV 25305-0130

# Request for Quotation

RFQ NUMBER  
**DNR209111**

PAGE  
**4**

ADDRESS CORRESPONDENCE TO ATTENTION OF  
**FRANK WHITTAKER  
 304-558-2316**

**\*709033753 800-438-2780**  
**CUNNINGHAM ASSOCIATES INC**  
**PO BOX 240981**  
**CHARLOTTE NC 28224**

**DIVISION OF NATURAL RESOURCES**  
**PINNACLE ROCK STATE PARK**  
**ATTN: PARK SUPERINTENDENT**  
**POST OFFICE BOX 704**  
**BLUEFIELD, WV**  
**24701 589-5307**

DATE PRINTED <b>04/14/2009</b>	TERMS OF SALE	SHIP VIA	F.O.B.	FREIGHT TERMS
-----------------------------------	---------------	----------	--------	---------------

BID OPENING DATE: **05/12/2009** BID OPENING TIME **01:30PM**

LINE	QUANTITY	UOP	CAT. NO.	ITEM NUMBER	UNIT PRICE	AMOUNT
				<p>( ) MAINTENANCE BOND: A TWO (2) YEAR MAINTENANCE BOND COVERING THE ROOFING SYSTEM WILL BE A REQUIREMENT OF THE SUCCESSFUL VENDOR.</p> <p>REV. 11/00</p> <p>EXHIBIT 7</p> <p>DOMESTIC ALUMINUM, GLASS &amp; STEEL IN PUBLIC WORKS PROJECTS</p> <p>IN ACCORDANCE WITH WEST VIRGINIA CODE 5-19-1 ET., SEQ., EVERY CONTRACT FOR CONSTRUCTION, RECONSTRUCTION, ALTERATION, REPAIR, IMPROVEMENT OR MAINTENANCE OF PUBLIC WORKS, WHERE THE COST IS MORE THAN \$50,000 AND, IN THE CASE OF STEEL ONLY, WHERE THE COST OF STEEL IS MORE THAN \$50,000 OR WHERE MORE THAN 10,000 POUNDS OF STEEL ARE REQUIRED, THE STATE WILL ACCEPT ONLY ALUMINUM GLASS, OR STEEL PRODUCTS PRODUCED IN THE UNITED STATES. IN ADDITION, ITEMS OF MACHINERY OR EQUIPMENT PURCHASED FOR USE AT THE SITE OF PUBLIC WORKS SHALL BE MADE OF DOMESTIC ALUMINUM, GLASS OR STEEL, UNLESS THE COST OF THE PRODUCT IS LESS THAN \$50,000 OR LESS THAN 10,000 POUNDS OF STEEL ARE USED IN PUBLIC WORKS PROJECTS.</p> <p>FOREIGN MADE ALUMINUM, GLASS OR STEEL PRODUCTS MAY BE ACCEPTED ONLY IF THE COST OF DOMESTIC PRODUCTS IS FOUND TO BE UNREASONABLE. SUCH COST IS UNREASONABLE IF IT IS 20% OR MORE HIGHER THAN THE BID PRICE FOR FOREIGN MADE PRODUCTS. IF THE DOMESTIC ALUMINUM, GLASS OR STEEL PRODUCTS TO BE SUPPLIED OR PRODUCED IN A "SUBSTANTIAL LABOR SURPLUS AREA", AS DEFINED BY THE UNITED STATES DEPARTMENT OF LABOR, FOREIGN PRODUCTS MAY BE SUPPLIED ONLY IF DOMESTIC PRODUCTS ARE 30% OR MORE HIGHER IN</p>		

SEE REVERSE SIDE FOR TERMS AND CONDITIONS

SIGNATURE *[Signature]* TELEPHONE **800-438-2780** DATE **5/7/09**

TITLE **Project Manager** FEIN **54-0583979** ADDRESS CHANGES TO BE NOTED ABOVE

WHEN RESPONDING TO RFQ, INSERT NAME AND ADDRESS IN SPACE ABOVE LABELED 'VENDOR'



State of West Virginia  
 Department of Administration  
 Purchasing Division  
 2019 Washington Street East  
 Post Office Box 50130  
 Charleston, WV 25305-0130

### Request for Quotation

RFQ NUMBER  
**DNR209111**

PAGE  
**5**

ADDRESS CORRESPONDENCE TO ATTENTION OF  
**FRANK WHITTAKER**  
**304-558-2316**

**VENDOR**

\*709033753      800-438-2780  
**CUNNINGHAM ASSOCIATES INC**  
**PO BOX 240981**  
  
**CHARLOTTE NC 28224**

**SHIP TO**

**DIVISION OF NATURAL RESOURCES**  
**PINNACLE ROCK STATE PARK**  
**ATTN: PARK SUPERINTENDENT**  
**POST OFFICE BOX 704**  
**BLUEFIELD, WV**  
**24701                      589-5307**

DATE PRINTED	TERMS OF SALE	SHIP VIA	F.O.B.	FREIGHT TERMS
04/14/2009				

BID OPENING DATE: **05/12/2009**      BID OPENING TIME **01:30PM**

LINE	QUANTITY	UOP	CAT NO	ITEM NUMBER	UNIT PRICE	AMOUNT
<p>PRICE THAN THE FOREIGN MADE PRODUCTS.</p> <p>IF, PRIOR TO THE AWARD OF A CONTRACT UNDER THE ABOVE PROVISIONS, THE SPENDING OFFICER OF THE SPENDING UNIT DETERMINES THAT THERE EXISTS A BID FOR LIKE FOREIGN ALUMINUM, GLASS OR STEEL THAT IS REASONABLE AND LOWER THAN THE LOWEST BID DOMESTIC PRODUCTS, THE SPENDING OFFICE MAY REQUEST, IN WRITING, A REEVALUATION AND REDUCTION IN THE LOWEST BID FOR SUCH DOMESTIC PRODUCTS. ALL VENDORS MUST INDICATE IN THEIR BID IF THEY ARE SUPPLYING FOREIGN ALUMINUM, GLASS OR STEEL.</p> <p>REV. 3/88</p> <p>EXHIBIT 9</p> <p>NOTICE FOR ISSUANCE &amp; ACKNOWLEDGEMENT OF CONSTRUCTION PROJECT ADDENDA</p> <p>THE ARCHITECT/ENGINEER AND/OR AGENCY SHALL BE REQUIRED TO ABIDE BY THE FOLLOWING SCHEDULE IN ISSUING CONSTRUCTION PROJECT ADDENDA FOR STATE AGENCIES:</p> <p>(1) THE ARCHITECT/ENGINEER SHALL PREPARE THE ADDENDUM AND A LIST OF ALL PARTIES THAT HAVE PROCURED DRAWINGS AND SPECIFICATIONS FOR THE PROJECT. THE ADDENDUM AND LIST SHALL BE FORWARDED TO THE BUYER IN THE STATE PURCHASING DIVISION. THE ARCHITECT/ENGINEER SHALL ALSO SEND A COPY OF THE ADDENDUM TO THE STATE AGENCY FOR WHICH THE CONTRACT IS ISSUED.</p> <p>(2) THE BUYER SHALL SEND THE ADDENDUM TO ALL INTERESTED PARTIES AND, IF NECESSARY, EXTEND THE BID OPENING DATE. ANY ADDENDUM SHOULD BE RECEIVED BY THE BUYER WITHIN FOURTEEN (14) DAYS PRIOR TO THE BID</p>						

SEE REVERSE SIDE FOR TERMS AND CONDITIONS

SIGNATURE *[Signature]*      TELEPHONE **800-438-2780**      DATE **5/7/09**

TITLE **Project Manager**      FEIN **54-0883979**      ADDRESS CHANGES TO BE NOTED ABOVE

WHEN RESPONDING TO RFQ, INSERT NAME AND ADDRESS IN SPACE ABOVE LABELED 'VENDOR'



State of West Virginia  
 Department of Administration  
 Purchasing Division  
 2019 Washington Street East  
 Post Office Box 50130  
 Charleston, WV 25305-0130

# Request for Quotation

RFQ NUMBER  
**DNR209111**

PAGE  
**6**

ADDRESS CORRESPONDENCE TO ATTENTION OF  
**FRANK WHITTAKER  
 304-558-2316**

**\*709033753 800-438-2780**  
**CUNNINGHAM ASSOCIATES INC**  
**PO BOX 240981**  
  
**CHARLOTTE NC 28224**

**DIVISION OF NATURAL RESOURCES**  
**PINNACLE ROCK STATE PARK**  
**ATTN: PARK SUPERINTENDENT**  
**POST OFFICE BOX 704**  
**BLUEFIELD, WV**  
**24701 589-5307**

DATE PRINTED <b>04/14/2009</b>	TERMS OF SALE	SHIP VIA	F.O.B.	FREIGHT TERMS
-----------------------------------	---------------	----------	--------	---------------

BID OPENING DATE: **05/12/2009** BID OPENING TIME **01:30PM**

LINE	QUANTITY	UOP	CAT NO	ITEM NUMBER	UNIT PRICE	AMOUNT
<p>OPENING DATE.</p> <p>(3) ALL ADDENDA SHOULD BE FORMALLY ACKNOWLEDGED BY ALL BIDDERS AND SUBMITTED TO THE STATE PURCHASING DIVISION. THE SAME RULES AND REGULATIONS THAT APPLY TO THE ORIGINAL BIDDING DOCUMENT SHALL ALSO APPLY TO AN ADDENDUM DOCUMENT. THE ONLY EXCEPTION MAY BE FOR AN ADDENDUM THAT IS ISSUED FOR THE SOLE PURPOSE OF CHANGING A BID OPENING TIME AND/OR DATE.</p> <p>REV. 11/96</p> <p>EXHIBIT 10</p> <p>ADDENDUM ACKNOWLEDGEMENT</p> <p>I HEREBY ACKNOWLEDGE RECEIPT OF THE FOLLOWING CHECKED ADDENDUM(S) AND HAVE MADE THE NECESSARY REVISIONS TO MY PROPOSAL, PLANS AND/OR SPECIFICATION, ETC.</p> <p>ADDENDUM NOS.:</p> <p>NO. 1 .. <i>Pre-Bid</i> .. <i>650-38</i></p> <p>NO. 2 ..</p> <p>NO. 3 ..</p> <p>NO. 4 ..</p> <p>NO. 5 ..</p> <p>I UNDERSTAND THAT FAILURE TO CONFIRM THE RECEIPT OF THE ADDENDUM(S) MAY BE CAUSE FOR REJECTION OF THE BIDS.</p>						

SEE REVERSE SIDE FOR TERMS AND CONDITIONS

SIGNATURE *[Signature]* TELEPHONE **800-438-2780** DATE **5/7/09**

TITLE **Project Manager** FEIN **54-0883979** ADDRESS CHANGES TO BE NOTED ABOVE

WHEN RESPONDING TO RFQ, INSERT NAME AND ADDRESS IN SPACE ABOVE LABELED 'VENDOR'



State of West Virginia  
 Department of Administration  
 Purchasing Division  
 2019 Washington Street East  
 Post Office Box 50130  
 Charleston, WV 25305-0130

# Request for Quotation

RFQ NUMBER  
**DNR209111**

PAGE  
**7**

ADDRESS CORRESPONDENCE TO ATTENTION OF  
**FRANK WHITTAKER  
 304-558-2316**

PURCHASING

\*709033753      800-438-2780  
**CUNNINGHAM ASSOCIATES INC**  
**PO BOX 240981**  
  
**CHARLOTTE NC 28224**

SHIP TO

**DIVISION OF NATURAL RESOURCES**  
**PINNACLE ROCK STATE PARK**  
**ATTN: PARK SUPERINTENDENT**  
**POST OFFICE BOX 704**  
**BLUEFIELD, WV**  
**24701                      589-5307**

DATE PRINTED <b>04/14/2009</b>	TERMS OF SALE	SHIP VIA	F.O.B.	FREIGHT TERMS
BID OPENING DATE: <b>05/12/2009</b>		BID OPENING TIME <b>01:30PM</b>		

LINE	QUANTITY	UOP	CAT NO	ITEM NUMBER	UNIT PRICE	AMOUNT
<p>VENDOR MUST CLEARLY UNDERSTAND THAT ANY VERBAL REPRESENTATION MADE OR ASSUMED TO BE MADE DURING ANY ORAL DISCUSSION HELD BETWEEN VENDOR'S REPRESENTATIVES AND ANY STATE PERSONNEL IS NOT BINDING. ONLY THE INFORMATION ISSUED IN WRITING AND ADDED TO THE SPECIFICATIONS BY AN OFFICIAL ADDENDUM IS BINDING.</p> <p>..... SIGNATURE  <i>GameTime c/o Cunningham Assoc.</i> ..... COMPANY            ..... DATE  <i>5/7/09</i></p> <p>REV. 11/96</p> <p>CONTRACTORS LICENSE</p> <p>WEST VIRGINIA STATE CODE 21-11-2 REQUIRES THAT ALL PERSONS DESIRING TO PERFORM CONTRACTING WORK IN THIS STATE MUST BE LICENSED. THE WEST VIRGINIA CONTRACTORS LICENSING BOARD IS EMPOWERED TO ISSUE THE CONTRACTORS LICENSE. APPLICATIONS FOR A CONTRACTORS LICENSE MAY BE MADE BY CONTACTING THE WEST VIRGINIA DIVISION OF LABOR CAPITOL COMPLEX, BUILDING 3, ROOM 319, CHARLESTON, WV 25305. TELEPHONE: (304) 558-7890.</p> <p>WEST VIRGINIA STATE CODE 21-11-11 REQUIRES ANY PROSPECTIVE BIDDER TO INCLUDE THE CONTRACTORS LICENSE NUMBER ON THEIR BID.</p> <p>BIDDER TO COMPLETE:            CONTRACTORS NAME: .... <i>Jet Cat Construction</i> .....</p>						

SEE REVERSE SIDE FOR TERMS AND CONDITIONS

SIGNATURE *[Signature]* TELEPHONE **800-438-2780** DATE **5/7/09**

TITLE *Project Manager* FEIN **54-0883979** ADDRESS CHANGES TO BE NOTED ABOVE

WHEN RESPONDING TO RFQ, INSERT NAME AND ADDRESS IN SPACE ABOVE LABELED 'VENDOR'





State of West Virginia  
 Department of Administration  
 Purchasing Division  
 2019 Washington Street East  
 Post Office Box 50130  
 Charleston, WV 25305-0130

# Request for Quotation

RFQ NUMBER  
**DNR209111**

PAGE  
**8**

ADDRESS CORRESPONDENCE TO ATTENTION OF  
**FRANK WHITTAKER**  
**304-558-2316**

PROCUREMENT

\*709033753      800-438-2780  
**CUNNINGHAM ASSOCIATES INC**  
**PO BOX 240981**  
  
**CHARLOTTE NC 28224**

SHIP TO

**DIVISION OF NATURAL RESOURCES**  
**PINNACLE ROCK STATE PARK**  
**ATTN: PARK SUPERINTENDENT**  
**POST OFFICE BOX 704**  
**BLUEFIELD, WV**  
**24701                      589-5307**

DATE PRINTED <b>04/14/2009</b>	TERMS OF SALE	SHIP VIA	F.O.B.	FREIGHT TERMS
-----------------------------------	---------------	----------	--------	---------------

BID OPENING DATE: **05/12/2009**      BID OPENING TIME **01:30PM**

LINE	QUANTITY	UOP	CAT NO.	ITEM NUMBER	UNIT PRICE	AMOUNT
				CONTRACTORS LICENSE NO.: <b>WV037072</b> .....		
				THE SUCCESSFUL BIDDER WILL BE REQUIRED TO FURNISH A COPY OF THEIR CONTRACTORS LICENSE PRIOR TO ISSUANCE OF A PURCHASE ORDER/CONTRACT		
				APPLICABLE LAW		
				THE WEST VIRGINIA STATE CODE, PURCHASING DIVISION RULES AND REGULATIONS, AND THE INFORMATION PROVIDED IN THE "REQUEST FOR QUOTATION" ISSUED BY THE PURCHASING DIVISION IS THE SOLE AUTHORITY GOVERNING THIS PROCUREMENT.		
				ANY INFORMATION PROVIDED IN SPECIFICATION MANUALS, OR ANY OTHER SOURCE, VERBAL OR WRITTEN, WHICH CONTRADICTS OR ALTERS THE INFORMATION PROVIDED FROM THE SOURCES AS DESCRIBED IN THE ABOVE PARAGRAPH IS VOID AND OF NO EFFECT.		
				BANKRUPTCY: IN THE EVENT THE VENDOR/CONTRACTOR FILES FOR BANKRUPTCY PROTECTION, THIS CONTRACT IS AUTOMATICALLY NULL AND VOID, AND IS TERMINATED WITHOUT FURTHER ORDER.		
				REV. 1/2005		
				NOTICE		
				A SIGNED BID MUST BE SUBMITTED TO:		
				DEPARTMENT OF ADMINISTRATION PURCHASING DIVISION BUILDING 15		

SEE REVERSE SIDE FOR TERMS AND CONDITIONS

SIGNATURE       TELEPHONE **800-438-2780**      DATE **5/7/09**

TITLE **Project Manager**      FEIN **54-0883979**      ADDRESS CHANGES TO BE NOTED ABOVE

WHEN RESPONDING TO RFQ, INSERT NAME AND ADDRESS IN SPACE ABOVE LABELED 'VENDOR'



State of West Virginia  
 Department of Administration  
 Purchasing Division  
 2019 Washington Street East  
 Post Office Box 50130  
 Charleston, WV 25305-0130

# Request for Quotation

RFO NUMBER
DNR209111

PAGE
9

ADDRESS CORRESPONDENCE TO ATTENTION OF
FRANK WHITTAKER 304-558-2316

VENDOR

\*709033753      800-438-2780  
 CUNNINGHAM ASSOCIATES INC  
 PO BOX 240981  
  
 CHARLOTTE NC 28224

SHIP TO

DIVISION OF NATURAL RESOURCES  
 PINNACLE ROCK STATE PARK  
 ATTN: PARK SUPERINTENDENT  
 POST OFFICE BOX 704  
 BLUEFIELD, WV  
 24701                      589-5307

DATE PRINTED	TERMS OF SALE	SHIP VIA	F.O.B.	FREIGHT TERMS
04/14/2009				

BID OPENING DATE: **05/12/2009**                      BID OPENING TIME **01:30PM**

LINE	QUANTITY	UOP	CAT. NO.	ITEM NUMBER	UNIT PRICE	AMOUNT
				2019 WASHINGTON STREET, EAST CHARLESTON, WV 25305-0130		
				THE BID SHOULD CONTAIN THIS INFORMATION ON THE FACE OF THE ENVELOPE OR THE BID MAY NOT BE CONSIDERED:		
				SEALED BID		
				BUYER: FRANK WHITTAKER-FILE 44		
				REQ. NO.: DNR209111		
				BID OPENING DATE: 05/12/2009		
				BID OPENING TIME: 1:30 PM		
				PLEASE PROVIDE A FAX NUMBER IN CASE IT IS NECESSARY TO CONTACT YOU REGARDING YOUR BID:		
				----- 704-525-7356 -----		
				PLEASE PRINT OR TYPE NAME OF PERSON TO CONTACT CONCERNING THIS QUOTE:		
				----- John Cunningham -----		
				***** THIS IS THE END OF RFQ DNR209111 *****		
				TOTAL:		\$38,851.90

SEE REVERSE SIDE FOR TERMS AND CONDITIONS			
SIGNATURE	TELEPHONE 800-438-2780	DATE 5/7/09	
TITLE Project Manager	FEIN 54-0883979	ADDRESS CHANGES TO BE NOTED ABOVE	

WHEN RESPONDING TO RFQ, INSERT NAME AND ADDRESS IN SPACE ABOVE LABELED 'VENDOR'

Pinnacle Rock State Park Playground Equipment  
PRICING SHEET

Item No.	Quantity	Description	Unit Price	Amount
1	1	Cre8Play Strato Rock Climber, Model #STRATO1, or equal.		See attached
2	1	Cre8Play Summit Rock Climber, Model #SUMMIT1, or equal.		↓
3	1	GameTime T-frame swing, Item #P831, or equal.		
4	1	GameTime T-frame zero-G chair, Item #8555, or equal.		
5	1	GameTime super seat-2, Item #1479.		
6	1,812 sq. ft.	Engineered wood fiber compacted @12 inches deep.		
7	1 roll	Geo-textile fabric, 2,250 sq. ft. roll, or equal.		
8	14	Six inch by six inch 16 foot long treated timbers for a border around playground area.		
9	1	Installation of items 1,2,3,4,5,6,7, and 8.		
10	1	Site preparation which includes the removal of six (6) stumps.		
		<b>TOTAL</b>		

WVDNR209065  
 Pinnacle Rock State Park  
**PLAYGROUND EQUIPMENT SHEET**

Please complete the below information concerning the brand(s) of equipment being bid in relation to this project. If bidding "or equal" brands, please attach manufacturer's literature documenting that it meets the mandatory requirements stated in the specifications. Vendors should note the areas of the provided manufacturer's literature that adheres to the mandatory requirements outlined in the Request For Proposal.

Item No.	Equipment	Manufacturer	Model
1	Cre8Play Strato Rock Climber, Model #STRATO1, or equal.		see attached
2	Cre8Play Summit Rock Climber, Model #SUMMIT1, or equal.		↓
3	GameTime T-frame swing, Item #P831, or equal.		
4	GameTime T-frame zero-G chair, Item #8555, or equal.		
5	GameTime super seat-2, Item #1479.		
6	Engineered wood fiber compacted @12 inches deep.		
7	Geo-textile fabric, 2,250 sq. ft. roll, or equal.		
8	Six inch by six inch 16 foot long treated timbers for a border around playground area.		
9	Installation of items 1,2,3,4,5,6,7, and 8.		
10	Site preparation which includes the removal of six (6) stumps.		



State of West Virginia  
DRUG FREE WORKPLACE CONFORMANCE AFFIDAVIT  
West Virginia Code §21-1D-5

STATE OF North Carolina

COUNTY OF Mecklenburg, TO-WIT:

I, John Cunningham, after being first duly sworn, depose and state as follows:

- 1. I am an employee of Cunningham Associates; and,  
(Company Name)
- 2. I do hereby attest that Cunningham Associates  
(Company Name)

maintains a valid written drug free workplace policy and that such policy is in compliance with **West Virginia Code** §21-1D-5.

The above statements are sworn to under the penalty of perjury.

Cunningham Associates  
(Company Name)

By: John Cunningham

Title: Project Manager

Date: 5/7/09

Taken, subscribed and sworn to before me this 7 day of May, 2009.

By Commission expires March 5, 2014

(Seal)

Cynthia A. Pasquelli  
(Notary Public)

**THIS AFFIDAVIT MUST BE SUBMITTED WITH THE BID IN ORDER TO COMPLY WITH WV CODE PROVISIONS. FAILURE TO INCLUDE THE AFFIDAVIT WITH THE BID SHALL RESULT IN DISQUALIFICATION OF THE BID.**

RFQ No. DNR209111

STATE OF WEST VIRGINIA  
Purchasing Division

## PURCHASING AFFIDAVIT

### VENDOR OWING A DEBT TO THE STATE:

**West Virginia Code §5A-3-10a** provides that: No contract or renewal of any contract may be awarded by the state or any of its political subdivisions to any vendor or prospective vendor when the vendor or prospective vendor or a related party to the vendor or prospective vendor is a debtor and the debt owed is an amount greater than one thousand dollars in the aggregate.

### PUBLIC IMPROVEMENT CONTRACTS & DRUG-FREE WORKPLACE ACT:

If this is a solicitation for a public improvement construction contract, the vendor, by its signature below, affirms that it has a written plan for a drug-free workplace policy in compliance with Article 1D, Chapter 21 of the **West Virginia Code**. The vendor **must** make said affirmation with its bid submission. Further, public improvement construction contract may not be awarded to a vendor who does not have a written plan for a drug-free workplace policy in compliance with Article 1D, Chapter 21 of the **West Virginia Code** and who has not submitted that plan to the appropriate contracting authority in timely fashion. For a vendor who is a subcontractor, compliance with Section 5, Article 1D, Chapter 21 of the **West Virginia Code** may take place before their work on the public improvement is begun.

### ANTITRUST:

In submitting a bid to any agency for the state of West Virginia, the bidder offers and agrees that if the bid is accepted the bidder will convey, sell, assign or transfer to the state of West Virginia all rights, title and interest in and to all causes of action it may now or hereafter acquire under the antitrust laws of the United States and the state of West Virginia for price fixing and/or unreasonable restraints of trade relating to the particular commodities or services purchased or acquired by the state of West Virginia. Such assignment shall be made and become effective at the time the purchasing agency tenders the initial payment to the bidder.

I certify that this bid is made without prior understanding, agreement, or connection with any corporation, firm, limited liability company, partnership or person or entity submitting a bid for the same materials, supplies, equipment or services and is in all respects fair and without collusion or fraud. I further certify that I am authorized to sign the certification on behalf of the bidder or this bid.

### LICENSING:

Vendors must be licensed and in good standing in accordance with any and all state and local laws and requirements by any state or local agency of West Virginia, including, but not limited to, the West Virginia Secretary of State's Office, the West Virginia Tax Department, West Virginia Insurance Commission, or any other state agencies or political subdivision. Furthermore, the vendor must provide all necessary releases to obtain information to enable the Director or spending unit to verify that the vendor is licensed and in good standing with the above entities.

### CONFIDENTIALITY:

The vendor agrees that he or she will not disclose to anyone, directly or indirectly, any such personally identifiable information or other confidential information gained from the agency, unless the individual who is the subject of the information consents to the disclosure in writing or the disclosure is made pursuant to the agency's policies, procedures and rules. Vendor further agrees to comply with the Confidentiality Policies and Information Security Accountability Requirements, set forth in <http://www.state.wv.us/admin/purchase/privacy/noticeConfidentiality.pdf>.

Under penalty of law for false swearing (**West Virginia Code §61-5-3**), it is hereby certified that the vendor affirms and acknowledges the information in this affidavit and is in compliance with the requirements as stated.

Vendor's Name: GameTime clo Cunningham Associates  
 Authorized Signature: [Signature] Date: 5/7/09



State of West Virginia  
 Department of Administration  
 Purchasing Division  
 2019 Washington Street East  
 Post Office Box 50130  
 Charleston, WV 25305-0130

# Request for Quotation

RFQ NUMBER
DNR209111

PAGE
1

ADDRESS CORRESPONDENCE TO ATTENTION OF:
FRANK WHITTAKER
304-558-2316

VENDOR

\*709033753      800-438-2780  
 CUNNINGHAM ASSOCIATES INC  
 PO BOX 240981  
  
 CHARLOTTE NC 28224

SHIP TO

DIVISION OF NATURAL RESOURCES  
 PINNACLE ROCK STATE PARK  
 ATTN: PARK SUPERINTENDENT  
 POST OFFICE BOX 704  
 BLUEFIELD, WV  
 24701      589-5307

DATE PRINTED	TERMS OF SALE	SHIP VIA	F.O.B.	FREIGHT TERMS
05/04/2009				

BID OPENING DATE: 05/12/2009      BID OPENING TIME 01:30PM

LINE	QUANTITY	UOP	CAT NO	ITEM NUMBER	UNIT PRICE	AMOUNT
***** ADDENDUM NO. 1 *****						
THIS ADDENDUM IS ISSUED TO PROVEDE THE ATTACHED:						
1) VENDOR TECHNICAL QUESTIONS & AGENCY RESPONSES.						
2) MANDATORY PRE-BID SIGN IN SHEET.						
BID OPENING DATE AND TIME REMAINS 05/12/09 AT 1:30 PM.						
0001	1	LS		650-38		
PLAYGROUND EQUIPMENT PINNACLE ROCK STATE PARK						
***** THIS IS THE END OF RFQ DNR209111 ***** TOTAL:						\$ 38,851.90

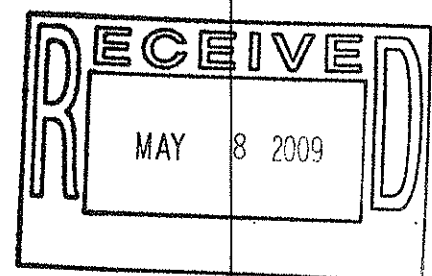

SEE REVERSE SIDE FOR TERMS AND CONDITIONS			
SIGNATURE <i>JR</i>	TELEPHONE 800-438-2780	DATE 5/7/09	
TITLE Project Manager	FEIN 54-0883979	ADDRESS CHANGES TO BE NOTED ABOVE	

WHEN RESPONDING TO RFQ, INSERT NAME AND ADDRESS IN SPACE ABOVE LABELED 'VENDOR'

Pinnacle Rock State Park  
Playground Equipment  
DNR209111

- 1.) What is to be done with the six stumps after they are removed?  
answer: The stumps are to be cleared of as much soil as possible and taken to a brush pile located one half mile away on park property.
- 2.) Which stumps are to be removed?  
answer: I marked the area and pointed out the exact stumps.
- 3.) On our drawing of the area, is the swing shown turned in the wrong direction?  
answer: Yes. It will need to be turned 90 degrees to allow for safety clearance.
- 4.) How will materials be able to be brought up on the narrow access road?  
answer: Large trucks will need to be unloaded in parking lot and playground equipment, mulch, and other supplies must be transported with forklift or suitable equipment.
- 5.) Does the park have any large equipment that can be borrowed?  
answer: No.
- 6.) Are concrete bases acceptable underneath the two climbing rocks? Is an addendum needed for this addition?  
answer: As stated in the playground specifications, the equipment is to be installed in a manner consistent with products recommendations by the company awarded the bid. No addendum will be required.
- 7.) Is it acceptable to have an infant swing and a belt swing together on a T-swing arrangement?  
answer: Once again as stated in the playground specifications, the equipment must be in compliance with U.S. Consumer Product Safety Commission and ASTM Standards. This must be documented by the vendor.
- 8.) Is it acceptable to allow a subcontractor to attend this pre-bid meeting to represent a company?  
answer: Yes. As long as the subcontractor only is in attendance to represent only one company.



PR-21-2009 TUE 11:57AM ID:

APR-29-2009 03:28P FROM:

### SIGN IN SHEET

Page \_\_\_\_\_ of \_\_\_\_\_

Request for Proposal No. \_\_\_\_\_

PLEASE PRINT

Date: \_\_\_\_\_

\* PLEASE BE SURE TO PRINT LEGIBLY - IF POSSIBLE, LEAVE A BUSINESS CARD

TELEPHONE & FAX NUMBERS

FIRM & REPRESENTATIVE NAME	MAILING ADDRESS	TELEPHONE & FAX NUMBERS
Company: Va. Playground Service / Little Tikes Rep: Roger Altizer Email Address: jim@va.playgrounds.com	14276 Riverside Dr. Ashland, Va 23005	PHONE 434-249-2158 TOLL FREE FAX 434-296-3289
Company: Playground Specialists Rep: Tammy Wood Email Address: tammy@playspec.com	17352 N. Seton Avenue Emmitsburg, MD 21727	PHONE 301-271-9236 TOLL FREE 800-385-0075 FAX 301-271-9239
Company: Service Supply Rep: Pam Melton Email Address: playgroundpam@yahoo	947 Sunset Terr. Milton, WV 25541	PHONE 304-743-5260 TOLL FREE 800-548-7550 FAX 304-743-3250
Company: CUNNINGHAM ASSOC / GARDNER ERECTOR Rep: LARRY FITZGERALD Email Address: LARRY@CUNNINGHAMASSOC.COM	Box 240981 CHARLOTTE, NC 28224	PHONE 800-438-2780 X151 TOLL FREE FAX 704-525-7356
Company: _____ Rep: _____ Email Address: _____	_____	PHONE _____ TOLL FREE _____ FAX _____

TO: 13045582165

P: 4/4

PAGE: 2

Page 3

THE AMERICAN INSTITUTE OF ARCHITECTS



AIA Document A310

Bid Bond

Bond No. ATLA-2009-2256

KNOW ALL MEN BY THESE PRESENTS, that we
GameTime, 150 PlayCore Drive, Fort Payne, AL 35967

(Here insert full name and address or legal title of Contractor)

as Principal, hereinafter called the Principal, and

(Here insert full name and address or legal title of Surety)

Berkley Regional Insurance Company
5900 Windward Parkway, #335, Alpharetta, GA 30005

a corporation duly organized under the laws of the State of Delaware
as Surety, hereinafter called the Surety, are held and firmly bound unto

(Here insert full name and address or legal title of Owner)

West Virginia State Parks

as Obligee, hereinafter called the Obligee, in the sum of Five Percent of Amount Bid
Dollars (\$ 5% of Bid ),
for the payment of which sum well and truly to be made, the said Principal and the said Surety, bind
ourselves, our heirs, executors, administrators, successors and assigns, jointly and severally, firmly by
these presents.

WHEREAS, the Principal has submitted a bid for

(Here insert full name, address and description of project)

Furnish & Install Playground Equipment - Pinnacle Rock
State Park (RFQ#DNR209111).

NOW, THEREFORE, if the Obligee shall accept the bid of the Principal and the Principal shall enter into a Contract
with the Obligee in accordance with the terms of such bid, and give such bond or bonds as may be specified in the bidding
or Contract Documents with good and sufficient surety for the faithful performance of such Contract and for the prompt
payment of labor and material furnished in the prosecution thereof, or in the event of the failure of the Principal to enter
such Contract and give such bond or bonds, if the Principal shall pay to the Obligee the difference not to exceed the penalty
hereof between the amount specified in said bid and such larger amount for which the Obligee may in good faith contract
with another party to perform the Work covered by said bid, then this obligation shall be null and void, otherwise to remain
in full force and effect. The attached Warranty Limitation Rider is a part of this bond.

Signed and sealed this 7th day of May 20 09

GameTime

By

[Signature of Mike Hawkins]

(Principal)

(Seal)

Mike Hawkins, VP Risk Mgmt
(Title)

[Signature of Maria Gomez]

(Witness)

Berkley Regional Insurance Company

(Surety)

(Seal)

[Signature of Virginia B. McManus]

(Title)

Virginia B. McManus, Attorney-in-fact

[Signature of Cheryl Wilson]

(Witness)

WARRANTY LIMITATION RIDER TO BID BOND

This Rider is an attachment to and forms a part of the bid bond executed by Berkley Regional Insurance Company ("Berkley"), as Surety, on behalf of GameTime ("Principal") and in favor of West Virginia State Parks ("Obligee") in connection with the bid submitted by the Principal on May 12, 2009 involving proposal for Furnish & Install Playground Equipment – Pinnacle Rock State Park (RFQ# DNR209111) "Contract").

---

It is the condition of this bid bond that the warranty obligations of Berkley under its final performance bond, notwithstanding any provision to the contrary in the proposed Contract or bid documents, shall not exceed one year from the date of substantial completion of the Principal's performance under the Contract, and that any claim by the Obligee under the performance bond must be discovered and asserted against Berkley within one year from the date of substantial completion of the Contract by the Principal. Any extended warranties provided in the Contract by the Principal and/or product manufacturers for workmanship or materials that exceed one year from the substantial completion date shall be the sole obligations of the Principal and/or the product manufacturers and shall be explicitly excluded from coverage under the performance bond to be provided by Berkley.

By acceptance of this bid bond, the Obligee acknowledges that the warranty obligations of Berkley Regional Insurance Company in the final performance bond shall not exceed one year from the date of the project's substantial completion.

By submission of this bid bond, the Principal acknowledges that Berkley has no liability to the Principal in the event that this bid bond is rejected by the Obligee.

Signed, sealed, and dated this 7th day of May, 2009.

Berkley Regional Insurance Company

By: Virginia B. McManus  
Virginia B. McManus, Attorney in Fact

POWER OF ATTORNEY  
BERKLEY REGIONAL INSURANCE COMPANY  
WILMINGTON, DELAWARE

NOTICE: The warning found elsewhere in this Power of Attorney affects the validity thereof. Please review carefully.

KNOW ALL MEN BY THESE PRESENTS, that BERKLEY REGIONAL INSURANCE COMPANY (the "Company"), a corporation duly organized and existing under the laws of the State of Delaware, having its principal office in Urbandale, Iowa, has made, constituted and appointed, and does by these presents make, constitute and appoint:

*Sandra S. Carter, Gary D. Eklund, Virginia B. McManus, Barbara S. MacArthur, Edward L. Mitchell, Nancy G. Nix or Chaun M. Wilson of Marsh USA Inc. of Atlanta, Georgia*

its true and lawful Attorney-in-Fact, to sign its name as surety only as delineated below and to execute, seal, acknowledge and deliver any and all bonds and undertakings, with the exception of Financial Guaranty Insurance, providing that no single obligation shall exceed Fifty Million and 00/100 Dollars (\$50,000,000.00), to the same extent as if such bonds had been duly executed and acknowledged by the regularly elected officers of the Company at its principal office in their own proper persons.

This Power of Attorney shall be construed and enforced in accordance with, and governed by, the laws of the State of Delaware, without giving effect to the principles of conflicts of laws thereof. This Power of Attorney is granted pursuant to the following resolutions which were duly and validly adopted at a meeting of the Board of Directors of the Company held on August 21, 2000:

"RESOLVED, that the proper officers of the Company are hereby authorized to execute powers of attorney authorizing and qualifying the attorney-in-fact named therein to execute bonds, undertakings, recognizances, or other suretyship obligations on behalf of the Company, and to affix the corporate seal of the Company to powers of attorney executed pursuant hereto; and further

RESOLVED, that such power of attorney limits the acts of those named therein to the bonds, undertakings, recognizances, or other suretyship obligations specifically named therein, and they have no authority to bind the Company except in the manner and to the extent therein stated; and further

RESOLVED, that such power of attorney revokes all previous powers issued on behalf of the attorney-in-fact named; and further

RESOLVED, that the signature of any authorized officer and the seal of the Company may be affixed by facsimile to any power of attorney or certification thereof authorizing the execution and delivery of any bond, undertaking, recognizance, or other suretyship obligation of the Company; and such signature and seal when so used shall have the same force and effect as though manually affixed. The Company may continue to use for the purposes herein stated the facsimile signature of any person or persons who shall have been such officer or officers of the Company, notwithstanding the fact that they may have ceased to be such at the time when such instruments shall be issued."

IN WITNESS WHEREOF, the Company has caused these presents to be signed and attested by its appropriate officers and its corporate seal hereunto affixed this 29 day of December, 2008.

Attest:

Berkley Regional Insurance Company

(Seal)

By

Ira S. Lederman  
Senior Vice President & Secretary

By

Robert P. Cole  
Senior Vice President

WARNING: THIS POWER INVALID IF NOT PRINTED ON BLUE "BERKLEY" SECURITY PAPER.

STATE OF CONNECTICUT )

) ss:

COUNTY OF FAIRFIELD )

Sworn to before me, a Notary Public in the State of Connecticut, this 29 day of December, 2008, by Robert P. Cole and Ira S. Lederman who are sworn to me to be the Senior Vice President, and the Senior Vice President and Secretary, respectively, of Berkley Regional Insurance Company.

EILEEN KILLEEN  
NOTARY PUBLIC  
MY COMMISSION EXPIRES JUNE 30, 2012

Eileen Killeen  
Notary Public, State of Connecticut

CERTIFICATE

I, the undersigned, Assistant Secretary of BERKLEY REGIONAL INSURANCE COMPANY, DO HEREBY CERTIFY that the foregoing is a true, correct and complete copy of the original Power of Attorney; that said Power of Attorney has not been revoked or rescinded and that the authority of the Attorney-in-Fact set forth therein, who executed the bond or undertaking to which this Power of Attorney is attached, is in full force and effect as of this date.

Given under my hand and seal of the Company, this 7th day of May, 2009.

(Seal)

Steven J. Coward  
Steven Coward

WARNING -- Any unauthorized reproduction or alteration of this document is prohibited. This power of attorney is void unless seals are readable and the certification seal at the bottom is embossed. The background imprint, warning and confirmation (on reverse) must be in blue ink.



State of West Virginia  
 Department of Administration  
 Purchasing Division  
 2019 Washington Street East  
 Post Office Box 50130  
 Charleston, WV 25305-0130

request for  
 Quotation

RFQ NUMBER
DNR209111

PAGE
1

ADDRESS CORRESPONDENCE TO ATTENTION OF
FRANK WHITTAKER 304-558-2316

\*709033753 800-438-2780  
 CUNNINGHAM ASSOCIATES INC  
 PO BOX 240981  
 CHARLOTTE NC 28224

DIVISION OF NATURAL RESOURCES  
 PINNACLE ROCK STATE PARK  
 ATTN: PARK SUPERINTENDENT  
 POST OFFICE BOX 704  
 BLUEFIELD, WV  
 24701 589-5307

DATE PRINTED	TERMS OF SALE	SHIP VIA	FOB	FREIGHT TERMS
05/04/2009				

BID OPENING DATE: 05/12/2009 BID OPENING TIME: 01:30PM

LINE	QUANTITY	UOP	CAT NO	ITEM NUMBER	UNIT PRICE	AMOUNT
0001	1	LS		650-38		
***** THIS IS THE END OF RFQ DNR209111 ***** TOTAL: <u>\$38,851.90</u>						

SEE REVERSE SIDE FOR TERMS AND CONDITIONS		
SIGNATURE	TELEPHONE	DATE
	800-438-2780	5/7/09
TITLE	FERN	ADDRESS CHANGES TO BE NOTED ABOVE
Project Manager	54-0883979	

WHEN RESPONDING TO RFQ, INSERT NAME AND ADDRESS IN SPACE ABOVE LABELED 'VENDOR'

SIGN IN SHEET

Page \_\_\_\_\_ of \_\_\_\_\_

Request for Proposal No. \_\_\_\_\_

PLEASE PRINT

Date: \_\_\_\_\_

\* PLEASE BE SURE TO PRINT LEGIBLY - IF POSSIBLE, LEAVE A BUSINESS CARD

TELEPHONE & FAX NUMBERS

FIRM & REPRESENTATIVE NAME

MAILING ADDRESS

FIRM & REPRESENTATIVE NAME	MAILING ADDRESS	TELEPHONE & FAX NUMBERS
Company: Va. Playground Service / Little Tikes Rep: Roger Altizer Email Address: jio1@va-playgrounds.com	14276 Riverside Dr. Ashland, VA 23005	PHONE 434-249-2158 TOLL FREE FAX 434-296-3289
Company: Playground Specialists Rep: Tammy Wood Email Address: tammy@playspec.com	17352 N. Seton Avenue Emmitsburg, MD 21727	PHONE 301-271-9236 TOLL FREE 800-385-0075 FAX 301-271-9239
Company: Service Supply Rep: Jan Melton Email Address: play-ground-pam@yahoo.com	907 Sunset Terr. Milton, WV 25541	PHONE 304-743-5260 TOLL FREE 800-843-7556 FAX 304-743-3250
Company: CUNNINGHAM ASSOC / ELEGANT PLAY Rep: LARRY FITZGERALD Email Address: LARRY@CUNNINGHAMASSOC.COM	Box 240981 Charlotte, NC 28224	PHONE 800-438-2780 X151 TOLL FREE FAX 704-525-7356
Company: _____ Rep: _____ Email Address: _____	_____	PHONE _____ TOLL FREE _____ FAX _____

PRC-29-2009 03:28P FROM:

TO: 13245582165

P:4/4

Page 3

09-21-2009 TUE 11:57AM ID:

PAGE:2

Pinnacle Rock State Park  
Playground Equipment  
DNR209111

- 1.) What is to be done with the six stumps after they are removed?  
answer: The stumps are to be cleared of as much soil as possible and taken to a brush pile located one half mile away on park property.
- 2.) Which stumps are to be removed?  
answer: I marked the area and pointed out the exact stumps.
- 3.) On our drawing of the area, is the swing shown turned in the wrong direction?  
answer: Yes. It will need to be turned 90 degrees to allow for safety clearance.
- 4.) How will materials be able to be brought up on the narrow access road?  
answer: Large trucks will need to be unloaded in parking lot and playground equipment, mulch, and other supplies must be transported with forklift or suitable equipment.
- 5.) Does the park have any large equipment that can be borrowed?  
answer: No.
- 6.) Are concrete bases acceptable underneath the two climbing rocks? Is an addendum needed for this addition?  
answer: As stated in the playground specifications, the equipment is to be installed in a manner consistent with products recommendations by the company awarded the bid. No addendum will be required.
- 7.) Is it acceptable to have an infant swing and a belt swing together on a T-swing arrangement?  
answer: Once again as stated in the playground specifications, the equipment must be in compliance with U.S. Consumer Product Safety Commission and ASTM Standards. This must be documented by the vendor.
- 8.) Is it acceptable to allow a subcontractor to attend this pre-bid meeting to represent a company?  
answer: Yes. As long as the subcontractor only is in attendance to represent only one company.



**CUNNINGHAM ASSOCIATES INC.**  
Park & Playground Products

**Pinnacle Rock State Park - BID**

West Virginia State Parks  
Attn: Ken Caplinger  
Capitol Complex  
Building 3, Room 712  
Charleston, WV 25305  
Phone: 304-558-2764

**QUOTE**

5/6/2009

# 61088

Ship To Zip: 25305

Quantity	Part #	Description
1	STRATO	Cre8play - Strato Rock
1	SUMMIT	Cre8play - Summit Rock
1	P831	GameTime - T-Swing (painted), 3 1/2" Od
1	1479	GameTime - 3 1/2" Super Seat 2-Galv Chain
1	8555	GameTime - 3 1/2" Zero-G Chair (2-5)-Galv Chain
1812	EWf	GT-Impax - Engineered Wood Fiber @ 12" Compacted Depth
1	161290	GameTime - Geo-Textile 2250 Sq Ft Roll
1	INSTALL	MISC - Installation of Above Equipment - Includes: Installation of (1) Strato Rock, (1) Summit Rock, (1) T-Swing and (2) Seats. Removal of stumps, hauling fill dirt, grade to matching grade of driveway. Installation of felt and 1,812 ft2 of surfacing. Provide and Install 190 LF of Timber Border. Coat drive w/ water based sealants and mark sites.
1	BOND	MISC - Performance & Payment Bond

Site must be level and free of obstructions.

**Total Amount: \$38,851.90**

Pricing: Prices are firm for 30 days unless otherwise noted.

Shipment: Order shipped 30-45 day after receipt of order and acceptance of your purchase order, color selections, approved submittals, (if required) unless otherwise noted. It is the responsibility of the owner to offload and inventory equipment, unless other arrangements have been made. Missing or damaged equipment must be reported within 60 days of acceptance of delivery

Payment Terms: Net 30 days subject to approval by Credit Manager. A signed P.O. made out to Gametime C/O Cunningham Associates, Inc. or this signed quotation is required for all orders.

Acceptance of this proposal indicates your agreement to the terms and condition stated herein.

Site should be level and allow for unrestricted access of trucks and machinery. Customer shall be responsible for unknown conditions such as buried utilities, tree stumps, rock, or any concealed materials or conditions that may result in additional labor or materials cost. Customer will be billed hourly or per job for any additional costs.







**6-1-07**

**WARRANTIES: LIMITED FIVE-YEAR WARRANTY.** The STRATO and SUMMIT Rock Climbers sold under this contract are warranted to be free from manufacturing defects, in workmanship and materials for five years. If the purchaser discovers within this period a failure of the product to conform to specifications, or a defect in material or workmanship, the purchaser must promptly notify CRE8PLAY in writing within fifteen thirty (15) days of discovering the defect. Within a reasonable time after notification, at the sole option of CRE8PLAY, repair or correct these products if defective in manufacturing workmanship, materials or parts only, labor is excluded. CRE8PLAY extends this warranty only to the original purchaser. No other affirmation by CRE8PLAY or its representatives, by words or action, shall constitute a warranty.

This warranty does not apply to:

1. Damage resulting from improper use.
2. Any product, components or parts not supplied by CRE8PLAY
3. Defects generated by uses other than those for which it was created.
4. Damage resulting from vandalism.
5. Damage resulting from natural catastrophic events.
6. Normal expected wear or weathering such as color changes, minor scratches or normal weather related stains.
7. Accidents, injuries or liabilities which result from the use of CRE8PLAY products and services.
8. Damage caused during shipment.
9. Damage which results from incorrect installation that does not conform to CRE8PLAY instructions and specifications.
10. Warranty is void if sand or pea gravel safety surfacing is used as a resilient surface under products.

This warranty period of 60 months begins on the date that CRE8PLAY Products are shipped. The warranty starting and ending dates do not coincide with payment dates or the completion of work done by others. NOTE: All concrete has naturally occurring hairline cracks and these are not product defects.

**custom themed play ENVIRONMENTS**

CRE8PLAY, LLC • 4645 Yorktown Lane N. • Plymouth, MN 55442  
Phone 612.670.8195 Fax 612.486.7740 • www.cre8play.com • info@cre8play.com

# STRATO™ ROCK CLIMBER

## Installation Instructions

### SPECIFICATIONS AND DESCRIPTION

Manufactured from color integrated Glass Fiber Reinforced Concrete (GFRC) over structural steel frame. Glass fiber is Alkali Resistant (AR) type glass formulated for concrete. GFRC shall be 1,500 pounds per square inch in tension, 5,000 pounds per square inch in compression. Hardened GFRC is colored with an Alkali reactive chemical stain, which permanently changes the surface color of the concrete. Final coloring is achieved with latex stain made for concrete. GFRC is readily repairable no matter the age of the material.

The estimated delivery date will be confirmed within 24 hours prior to shipping. If delivery date is changed a service charge of 10% of the shipping charge will be added to the rescheduled shipping.

It is the responsibility of the installation contractor to coordinate with the driver to insure timely offloading. The truck will remain on-site for 2 hours after the appointed delivery time. After this period there would be a fee of \$50 per hour

### INSTALLATION

Read installation instructions thoroughly before starting installation process.

1. Foundation shall be prepared in advance of delivery of the climber. Base shall be compacted stone base - 12" minimum thickness with a vibratory compactor - to be determined by local soil conditions. Density requirement is 95% compaction with final condition of stone as level and stable so as not to shift when traveled on or during surface installation process. Area shall be 8'6" x 8'6".
2. STRATO is shipped in one piece on a Flatbed Semi to site. Fork Lift pockets are built in for lifting. Placement of components shall be placed with a Lull-type Forklift, Crane or Boom Truck capable of lifting 6,000 pounds centered on the compacted stone foundation. Test overall stability and rigidity of equipment. Take care in protecting the STRATO by not to make contact with concrete surface with installation equipment.
3. Shock absorbing properties of safety surfacing materials vary. If you determine that less or more than 12" of surfacing is required, make up the difference in elevation with earth and base before applying the surfacing. A soft, resilient surface should be placed around all climbers, extending at least eight feet in all directions surrounding the climber. NEVER INSTALL PLAY EQUIPMENT ON CONCRETE OR ASPHALT. A fall on a hard surface can result in serious injury to the equipment user.

ELEVATION

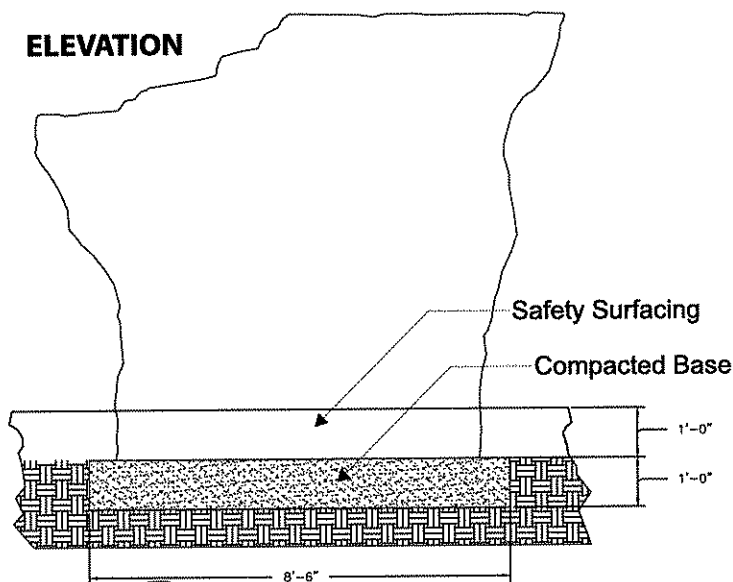

PLAN VIEW

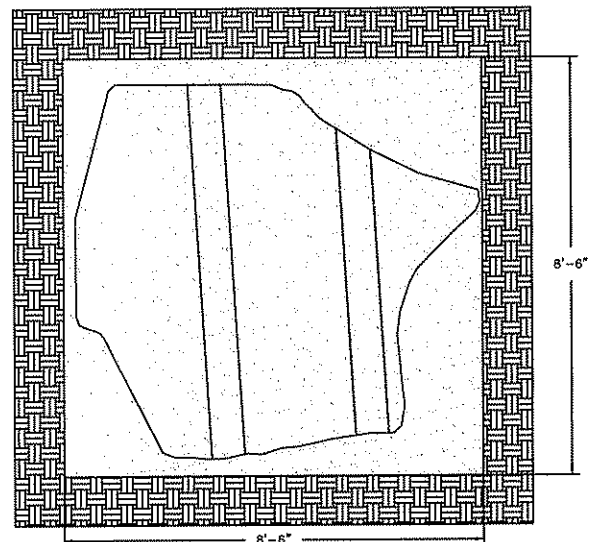

We put the 'fun' in Functional.

custom themed play ENVIRONMENTS

CRE8PLAY, LLC • 4645 Yorktown Lane N. • Plymouth, MN 55442 • Phone 612.670.8195 Fax 612.486.7740 • info@cre8play.com

# STRATO™

## ROCK CLIMBER

# Installation Instructions



Start with a base of compacted aggregate

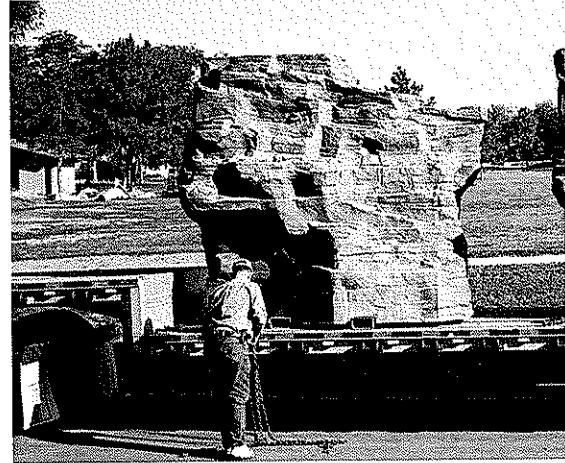

STRATO is shipped in one piece on a Flatbed Semi

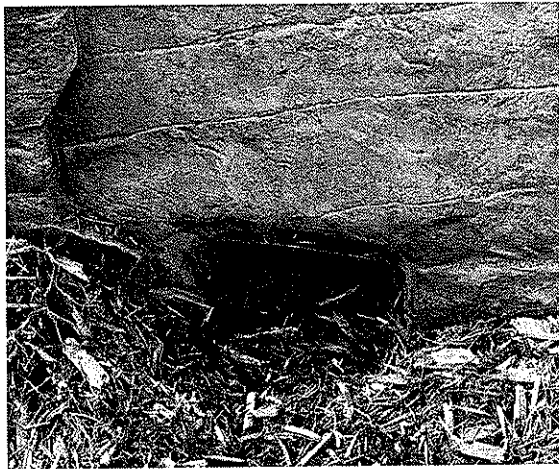

Forklift pockets built in for Lifting

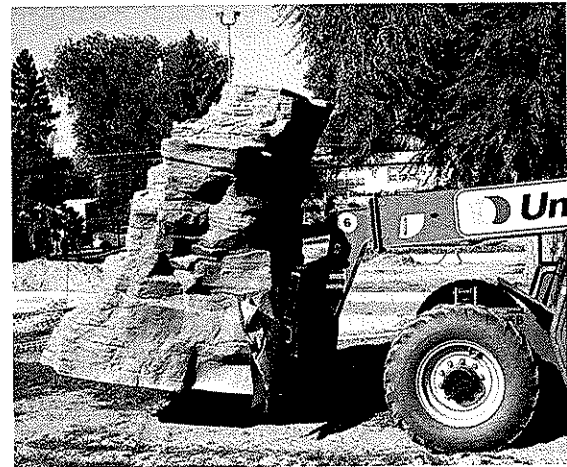

Lower the STRATO into place with a Lull-type Forklift, Crane or Boom

**WARNING**  
 INSTALLATION OVER  
 A HARD SURFACE  
 SUCH AS CONCRETE,  
 ASPHALT, OR PACKED  
 EARTH MAY RESULT  
 IN SERIOUS INJURY  
 OR DEATH  
 FROM FALLS.

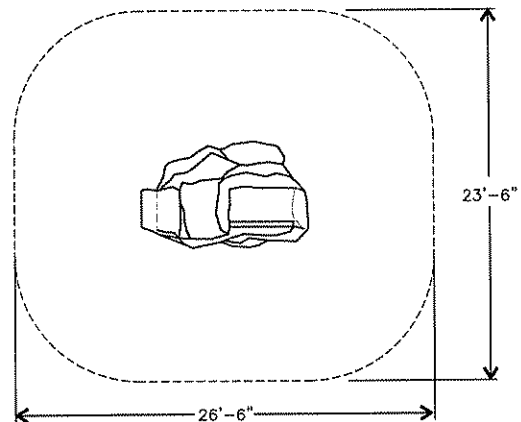

We put the 'fun' in Functional.

custom themed play ENVIRONMENTS

CRE8PLAY, LLC • 4645 Yorktown Lane N. • Plymouth, MN 55442 • Phone 612.670.8195 Fax 612.486.7740 • info@cre8play.com

Lookout  
Ridge

8595 Central Park Place • Woodbury, MN

A themed, life-like design and sound effects accompany slides, forests, a tree house, and even a cave. Kids are able to climb inside cliffs imitating the St. Croix River Valley, then zoom down a mountain spiral slide emerging from a cave. Children also can venture to the top of the tree house, cross over to the gigantic fallen tree, and race down a 30-foot superslide! For a more challenging adventure, kids can explore the tree foam forest and cross through the tube jam.

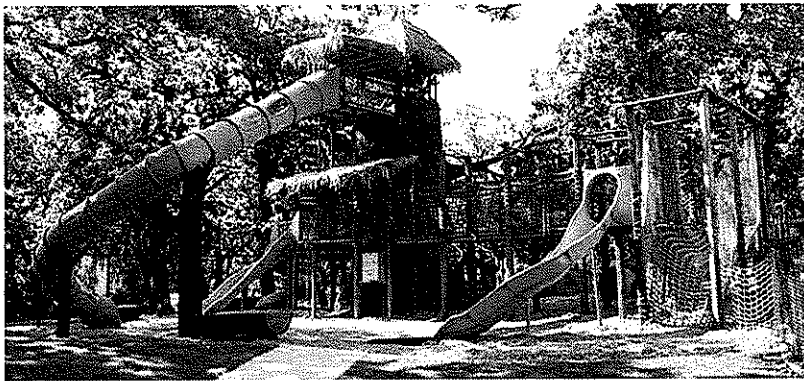
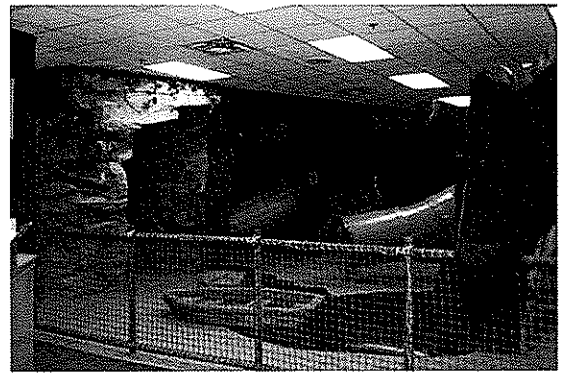

Edina Aquatic Center  
4300 W. 66th St. • Edina, MN 55436  
612-928-4582

To enjoy a little out-of-the-water fun, the City of Edina created to the Oakwood Forest. Climb up the hollowed trunk of the magical tree house to reach the look-out tower. After viewing the whole facility from the tower, climb down and enjoy the slides, monkey bars, bridges, and rope climbing. Hide in the crawl-through log or get caught in the spider web. Make friends with the hippopotamus, alligator and giraffe that watch over the play area. This dry playground offers a plethora of activities when you need a break from the water.

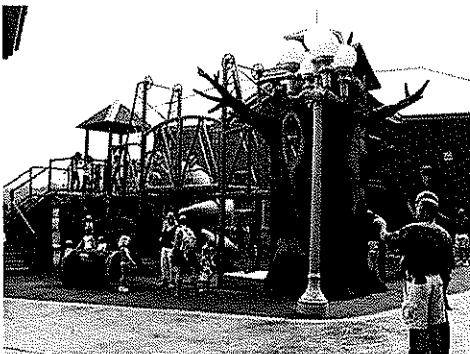

TEDDY  
BEAR  
PARK

Located at South 2nd Street and Nelson Street near downtown Stillwater. The park play equipment is designed for children younger than 8 years of age.



15200 Hanson Blvd NW • Andover, MN 55304  
(763) 230-9622





**City of Springfield, MO.**

Springfield-Greene County Park - Miles Park  
417-864-1326. The 207-acre farm park was created to provide educational, as well as various recreational resources for the community and will celebrate the rich agricultural heritage of the area.

Amenities include a new animal barn, new visitor's center and gift shop, and milking barn, farm-themed playground, and Wilson's Creek. This farm themed play environment is unlike anything else. Climbing up a giant Hay Bail, exploring the inside of a Barn and scaling rock formations



**City of Woodbury, MN** Bob Klatt 651-714-3580

A themed life-like design and sound effect accompany slides, forests, a tree house and even a cave. Kids are able to climb inside cliffs, imitating the St. Croix River Valley, then zoom down a mountain

spiral slide emerging from a cave. Children also can venture to the top of the tree house, cross over to the gigantic fallen tree and race down a 30-foot super-slide! For a more challenging adventure, kids can explore the tree foam forest and cross through the tube jam.

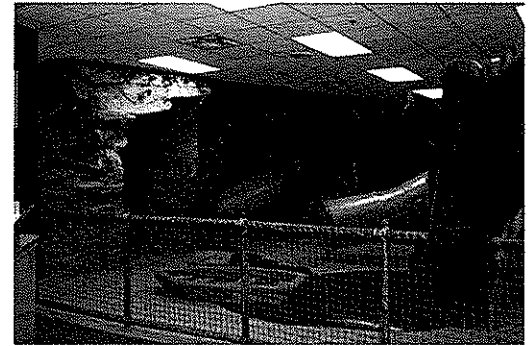

**Edina Aquatic Center** - 952-928-4582

To enjoy a little out-of-the-water fun, the City of Edina created the Oakwood Forest. Climb up the hollow trunk of the magical tree house to reach the look-out tower. After viewing the whole facility from the tower, climbing down and

enjoy the slides, monkey bars, bridges, and rope climbing. Hide in the cral-through log or get caught in the spider web. Make friends with the hippopotamus, alligator and giraffe that watch over the play area. This dry playground offers a plethora of activities when you need a break from the water.



**Dulles 28 Centre**, a 150,000 square foot lifestyle shopping center is located near the Dulles Airport. This unique Airport themed structure is manufactured from concrete and steel - (It's amazing what we can do with concrete!) The environment just wouldn't be complete without the awesome themed surfacing with a runway, pond, walking path and runway lights. So, fasten your seat belts, we're taking play to a whole new altitude!



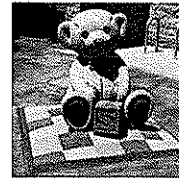
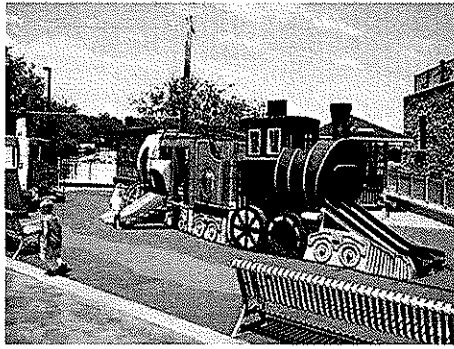
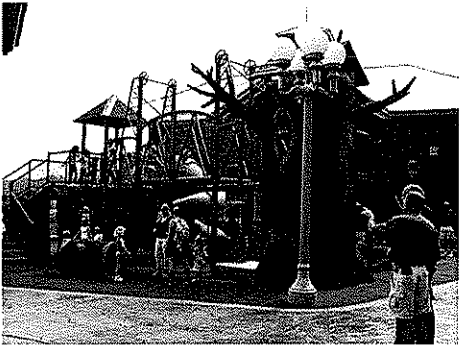

## Teddy Bear Park

Dewey Thorbeck - 612-871-7979. Teddy Bear Park is geared to children ages 6 months to 7 years. It includes a small amphitheater, a gazebo, themed play structures featuring antique toys and Stillwater's history, a sandbox with a train station, and climbing walls. The park includes separate play areas for children of different ages.



**Bowen Park**  
City of Waukegan working with Hitchcock design group was looking to create a realistic

Play environment including giant log climbers, and fungi climbers to help kids get back to nature. These log climbers are over 16' in length. Each includes details such as wood pecker holes, talk tubes, and mushrooms growing from the bark.

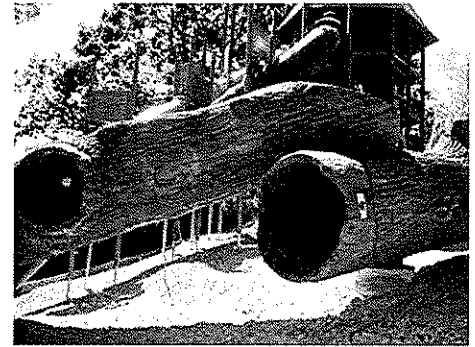
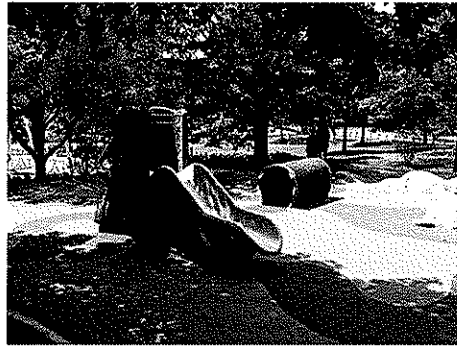

**Gateway Wetlands** - City of Bolingbrook's Gateway Wetlands is one of the few remaining federally-protected wetlands in Illinois. We worked closely with the City and architect to create a nature themed structure that would blend into the surroundings and offer the residents a one of a kind play environment.



The YMCA was looking to create a unique play experience to attract kids and parents alike to a whimsical north woods camping experience. We used products that were suitable for the age appropriateness and challenge level they were looking for. We completed the theme with murals and wall art and hanging elements. The smaller kids can climb across soft boulders while the older players can climb the trees and hang out in the fort log cabin.

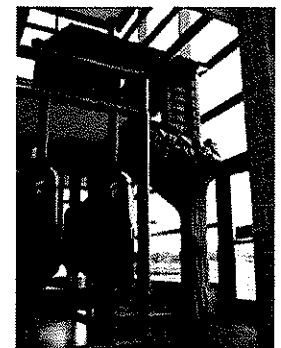

# MARSH

## CERTIFICATE OF INSURANCE

CERTIFICATE NUMBER  
ATL-001038993-07

**PRODUCER**  
MARSH  
3475 PIEDMONT ROAD NE  
SUITE 1200  
ATLANTA, GA 30305  
Attn: Tami Rouse 404-995-3430

457102-GL-pg-02-03

**INSURED**  
Game Time  
a division of Playcore Wisconsin, Inc.  
150 GameTime Drive  
Fort Payne, AL 35967

THIS CERTIFICATE IS ISSUED AS A MATTER OF INFORMATION ONLY AND CONFERS NO RIGHTS UPON THE CERTIFICATE HOLDER OTHER THAN THOSE PROVIDED IN THE POLICY. THIS CERTIFICATE DOES NOT AMEND, EXTEND OR ALTER THE COVERAGE AFFORDED BY THE POLICIES DESCRIBED HEREIN.

### COMPANIES AFFORDING COVERAGE

COMPANY	A	STEADFAST INSURANCE COMPANY
COMPANY	B	NATIONAL UNION FIRE INSURANCE CO OF PITTSBURGH
COMPANY	C	OHIO CASUALTY INSURANCE CO
COMPANY	D	N/A

**COVERAGES** This certificate supersedes and replaces any previously issued certificate for the policy period noted below. 2  
THIS IS TO CERTIFY THAT POLICIES OF INSURANCE DESCRIBED HEREIN HAVE BEEN ISSUED TO THE INSURED NAMED HEREIN FOR THE POLICY PERIOD INDICATED NOTWITHSTANDING ANY REQUIREMENT, TERM OR CONDITION OF ANY CONTRACT OR OTHER DOCUMENT WITH RESPECT TO WHICH THE CERTIFICATE MAY BE ISSUED OR MAY PERTAIN. THE INSURANCE AFFORDED BY THE POLICIES DESCRIBED HEREIN IS SUBJECT TO ALL THE TERMS, CONDITIONS AND EXCLUSIONS OF SUCH POLICIES. AGGREGATE LIMITS SHOWN MAY HAVE BEEN REDUCED BY PAID CLAIMS.

CO LTR	TYPE OF INSURANCE	POLICY NUMBER	POLICY EFFECTIVE DATE (MM/DD/YY)	POLICY EXPIRATION DATE (MM/DD/YY)	LIMITS	
A	<b>GENERAL LIABILITY</b>	SC05344512-01	02/26/06	08/01/07	GENERAL AGGREGATE	\$ 5,000,000
	<input checked="" type="checkbox"/> COMMERCIAL GENERAL LIABILITY				PRODUCTS - COMP/OP AGG	\$ 2,000,000
	<input type="checkbox"/> CLAIMS MADE <input checked="" type="checkbox"/> OCCUR				PERSONAL & ADV INJURY	\$ 1,000,000
	OWNER'S & CONTRACTOR'S PROT				EACH OCCURRENCE	\$ 1,000,000
	<input checked="" type="checkbox"/> SIR \$150,000				FIRE DAMAGE (Any one fire)	\$ 50,000
					MED EXP (Any one person)	\$ EXCLUDED
	<b>AUTOMOBILE LIABILITY</b>				COMBINED SINGLE LIMIT	\$
	<input type="checkbox"/> ANY AUTO				BODILY INJURY (Per person)	\$
	<input type="checkbox"/> ALL OWNED AUTOS				BODILY INJURY (Per accident)	\$
	<input type="checkbox"/> SCHEDULED AUTOS				PROPERTY DAMAGE	\$
	<input type="checkbox"/> HIRED AUTOS					
	<b>GARAGE LIABILITY</b>				AUTO ONLY - EA ACCIDENT	\$
	<input type="checkbox"/> ANY AUTO				OTHER THAN AUTO ONLY:	
					EACH ACCIDENT	\$
					AGGREGATE	\$
B	<b>EXCESS LIABILITY</b>	BE 5190218	02/26/06	08/01/07	EACH OCCURRENCE	\$ 25,000,000
	<input checked="" type="checkbox"/> UMBRELLA FORM				AGGREGATE	\$ 25,000,000
	OTHER THAN UMBRELLA FORM				SIR	\$ 10,000
					WC STATUTORY LIMITS	OTHER
	<b>WORKERS COMPENSATION AND EMPLOYERS' LIABILITY</b>				EL EACH ACCIDENT	\$
	THE PROPRIETOR/PARTNERS/EXECUTIVE OFFICERS ARE				EL DISEASE-POLICY LIMIT	\$
	<input type="checkbox"/> INCL <input type="checkbox"/> EXCL				EL DISEASE-EACH EMPLOYEE	\$
	OTHER					
C	Excess Umbrella	ECO (07) 53059239	02/26/06	08/01/07	25,000,000 Excess 25,000,000	

DESCRIPTION OF OPERATIONS/LOCATIONS/VEHICLES/SPECIAL ITEMS

### CERTIFICATE HOLDER

For Informational Purposes Only

### CANCELLATION

SHOULD ANY OF THE POLICIES DESCRIBED HEREIN BE CANCELLED BEFORE THE EXPIRATION DATE THEREOF, THE INSURER AFFORDING COVERAGE WILL ENDEAVOR TO MAIL 30 DAYS WRITTEN NOTICE TO THE CERTIFICATE HOLDER NAMED HEREIN, BUT FAILURE TO MAIL SUCH NOTICE SHALL IMPOSE NO OBLIGATION OR LIABILITY OF ANY KIND UPON THE INSURER AFFORDING COVERAGE, ITS AGENTS OR REPRESENTATIVES, OR THE ISSUER OF THIS CERTIFICATE

MARSH USA INC.

BY: Walter Gilstrap

MM1(3/02)

*Walt Gilstrap*

VALID AS OF: 02/23/06

Industry standards set a minimum level that playground manufacturers must meet. We meet or exceed those standards, because we understand that the ultimate playground offers peace of mind as well as thrills. After all, we're parents too.



## American Society for Testing and Materials (ASTM)

We don't just follow the rules; we help create them. Several key people at GameTime, including our Manager of Compliance and Standards, serve on the ASTM committee that sets the standards for the entire playground industry. GameTime products conform to that standard, ASTM F1487-01, the Standard Consumer Safety Performance Specification for Playground Equipment for Public Use.

## CPSC

The Consumer Product Safety Commission is an independent agency within the United States Federal Government with the authority to inform the public of current product safety performance information and recommended practices. The CPSC first published their guidelines for public playgrounds in 1981 and have updated their publication since then. The current CPSC Handbook for Public Playground Safety, publication #325, is an excellent guide for owners and operators of public play environments.



## IPEMA Equipment Certification

GameTime is one of the founding members of IPEMA, and several of our people serve as board members, committee members and chairpersons of the association. In the interest of public playground safety, IPEMA provides a 3rd party certification, to validate conformance to established standards. Our use of the IPEMA seal is your assurance that GameTime has received written validation from an independent lab that the products associated with the seal conform with the ASTM standard, as well as the Canadian CSA standard CAN Z-614. A list of our validated products may be found on the IPEMA website, [www.ipema.org](http://www.ipema.org).



## IPEMA Surfacing Certification

GameTime's GT Impax product provides you with the assurance that our surfacing has been certified as compliant to the appropriate ASTM standard. In the interest of public playground safety, IPEMA provides a third party certification to validate a manufacturer's conformance to the ASTM F-1292-99 Standard Specification for Impact Attenuation of Surface Systems Under And Around Playground Equipment.

The use of the IPEMA Certification Seal displayed above signifies that the manufacturer has received written validation from the independent laboratory that the product associated with the use of the seal conforms with the requirements of ASTM F1292-99. A complete list of our validated products may be found on the IPEMA website at [www.ipema.com](http://www.ipema.com).



ADA

GameTime is the only manufacturer to have a lab partnership with an Institute for children with special needs, so that we can develop and test our accessible products for superiority before bringing them to market. GameTime is also the only manufacturer to meet accessibility guidelines on all of its pre-designed PowerScape Plus and PrimeTime playground plans. We also recommend accessible surfacing options. For more information, log on to [www.access-board.gov](http://www.access-board.gov)



ISO 9001:2000

GameTime is the first (and at this issue, the only) playground manufacturer to obtain the ISO9001:2000 standard. In order to obtain this certification, the company's manuals, policies, objectives and quality procedures are closely examined during a surveillance audit by ISO representatives. Strict attention is paid to policies and procedures in manufacturing, communication channels, system monitoring, customer relations and order processing, which are reviewed for consistency and standards. Companies who meet the standard are awarded the ISO designation.



TUV

An international organization that is a European Union Notified and Competent Body, providing testing and certification. Use of the TUV seal demonstrates that indicate that products have passed a comprehensive testing procedure based upon the European Harmonized Standard for Commercial Playground Equipment, and that the GameTime plant is regularly monitored by TUV.



Certificate Number #: 005400

Registration #: 0689-01



# CERTIFICATE OF REGISTRATION

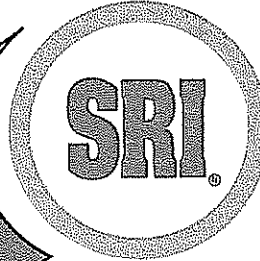
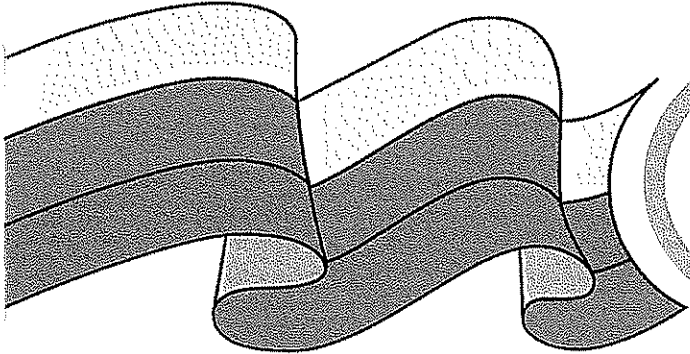

Quality  
System  
Registrar

Having been audited in accordance with requirements of

**ISO 9001:2000 - ANSI/ISO/ASQ Q9001-2000**

SRI Quality System Registrar, Wexford, Pennsylvania, USA, hereby grants to:

## **GameTime Division of Playcore**

registration of the quality system at its location:

**150 GameTime Drive  
Fort Payne, Alabama, USA**

The conditions for maintaining this certificate of registration are set forth in the SRI registration agreements R20.3 and R20.4. Further clarifications regarding the scope of this certificate and the applicability of ISO 9001:2000 requirements may be obtained by consulting the organization.

Scope of ISO 9001:2000 registration: "Design, manufacture and supply of park and playground equipment, site furnishings and rotational molded plastics."  
Exclusions: Control of Service Provision; Customer Property.

Initial registration date: September 18, 1996.  
Current registration period: September 18, 2005 through September 17, 2008.

Signed for SRI:

Peter B. Lake, CEO

Date: September 2, 2005

150 GameTime Drive  
Fort Payne, Alabama 35967  
Telephone: 256/845-6610  
Facsimile: 256/997-9653  
Email: service@gametime.com



## GAMETIME WARRANTIES

GameTime provides warranties on all materials and workmanship for one year, excluding vandalism. In addition, GameTime offers:

- ✓ Lifetime limited warranty on PowerScape® Plus, PrimeTime™ and TotStuff™ uprights.
- ✓ Lifetime limited warranty on all hardware.
- ✓ Lifetime limited warranty on GameTime PowerScape MegaLocs® and PowerLocks™.
- ✓ Ten-Year limited warranty on PrimeTime and TotTime bolt-through connection.
- ✓ Fifteen-Year limited warranty on rotationally molded KIDtime products.
- ✓ Fifteen-Year limited warranty on metal decks, pipes, rungs, rails and loops.
- ✓ Ten-Year limited warranty on pressure-treated pine and redwood products.
- ✓ Ten-Year limited warranty on Parcourse® fitness equipment.
- ✓ Fifteen-Year limited warranty on rotationally molded products.
- ✓ Five-Year limited warranty on SuperSeats™.
- ✓ Three-Year limited warranty on rubber or "C"-springs used on SaddleMates.
- ✓ One-Year limited warranty on all other GameTime products.

*All warranties specifically exclude damage caused by vandalism; negligence, improper installation or improper use; changes in appearance resulting from weathering; scratches, dents or marring as a result of use.*

*Warranties are valid only if products are installed and maintained in accordance with GameTime instructions and use approved parts.*

GTW030320

Page 1

### General warranty info

#### Lifetime Limited Warranty

PowerScape® Plus, PrimeTime™ and TotStuff™ uprights

All hardware

PowerScape PowerLocks™

#### 15 Year Limited Warranty

Rotationally molded products

Rotationally molded KidTime™ products

Metal decks

Pipes

Rungs

Rails

Loops

#### 10 Year Limited Warranty

PrimeTime bolt-through connections

Parcourse® fitness equipment

#### 5 Year Limited Warranty

Super Seats

#### 3 Year Limited Warranty

Rubber or "C" springs used on SaddleMates®

#### 1 Year Limited Warranty

All other GameTime products

**GameTime offers you peace of mind with one of the best, most all encompassing warranties in the industry.**

We want to assure you that we are part of your community playground long after the sales is made. Our quality is legendary, and we stand behind our products with one of the best warranties in the business. For complete Warranty information, consult your GameTime sales representative.

For the purpose of this warranty, "lifetime" encompasses no specific term of years, but rather that seller warrants to its original customer for as long as the original customer owns the product and uses the product for its intended purpose that the product and all its parts will be free from defects in material and manufacturing workmanship.

# GameTime Order Check Sheet

Please include all checked items (✓) with your order.

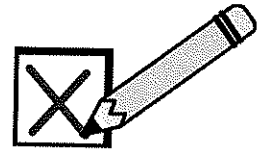

✓ Signed Proposal

✓ Signed Purchase Order made out to GameTime c/o Cunningham Associates, Inc.

✓ Signed GameTime Color Selection Form

✓ Billing Address: \_\_\_\_\_  
\_\_\_\_\_  
\_\_\_\_\_  
\_\_\_\_\_

✓ Contact Person: \_\_\_\_\_

Phone: (\_\_\_\_\_) \_\_\_\_\_ Fax: (\_\_\_\_\_) \_\_\_\_\_

✓ Shipping Address: \_\_\_\_\_  
\_\_\_\_\_  
\_\_\_\_\_

✓ Contact Person: \_\_\_\_\_

Phone: (\_\_\_\_\_) \_\_\_\_\_ Fax: (\_\_\_\_\_) \_\_\_\_\_

✓ Tax Exempt Number & Certificate (or tax will be added): \_\_\_\_\_

*Please send everything back to the office by fax and/or mail.*

⇒ Terms are Net 30 with approved Credit. No retainage allowed.

⇒ Shipment will be 30-45 days after factory receipt of all information checked above.

⇒ It is the responsibility of the owner to offload and inventory equipment, unless otherwise noted.

Missing or damaged equipment must be reported within 60 days from acceptance of delivery.

⇒ It is the responsibility of the owner to provide installation, safety surfacing, borders, site preparation, drainage, or other costs, unless otherwise noted in the proposal.

If you have any questions please call:

Design/Sales Questions Courtney (ext. 128) or Kerri (ext. 120)

Order Entry/Delivery Questions Courtney (ext. 128) or Kerri (ext. 120)

Represented by: Cunningham Associates, Inc.

P.O. Box 240981 • Charlotte, NC 28224 • (800) 438-2780 • Fax (704) 525-7356

# GameTime Color Selection Sheet



**Equipment Type:**  Xscape  PowerScape  PrimeTime (Choose Custom Colors or a Play Palette)

**Custom Colors:**

Upright Metal Color: \_\_\_\_\_

Accent Metal Color: \_\_\_\_\_

Deck TuffClad Color: \_\_\_\_\_

Slide & Panel Plastic Color: \_\_\_\_\_

Roof Plastic, Metal, or Timber Color: \_\_\_\_\_

(Plastic roof may be one-color or multi-color. Please list colors in order)

Tube Plastic Color: \_\_\_\_\_

(Tube may be one-color or multi-color. Please let colors in order)

MegaRock or WallCano Rock Color: \_\_\_\_\_ Handhold Color: \_\_\_\_\_

Net Climber: \_\_\_\_\_

SunBlox Roof & Shade Color: \_\_\_\_\_

**Play Palette:** (Choose one from list below) \_\_\_\_\_

**KidTime Play Palette:** (circle one) Natural Primary Contemporary

**Freestanding Play Events, Fitness, Site Furnishings, Shade:**

\_\_\_\_\_  
 \_\_\_\_\_  
 \_\_\_\_\_

- |                     |                    |                                  |                                                 |
|---------------------|--------------------|----------------------------------|-------------------------------------------------|
| <b>Metals:</b>      | <b>Plastics</b>    | <b>1-Color Poly Panel (HPDE)</b> | <b>Timber Décor:</b> Redwood or Cedar           |
| Yellow Butterscotch | Yellow Red         | Red Yellow Green                 |                                                 |
| Red Burgundy        | Purple Blue        | Blue Beige                       | <b>TuffClad</b>                                 |
| Purple Blue         | Teal Green         |                                  | Red Brown Blue Dark Green                       |
| Teal Green          | Brown Beige        | <b>2-Color Poly Panel</b>        | <b>Net Climbers:</b> Red Blue Green             |
| Dark Green Brown    | Gray               | Outside/Inside Color             | <b>Xscape Nets:</b> Red Black                   |
| Beige Gray          | <b>Rock Colors</b> | Red/Yellow Yellow/Red            |                                                 |
| Metallic Black      | Sandstone Granite  | Green/Beige Blue/Beige           |                                                 |
| White               |                    |                                  | <b>WallCano Handholds:</b> Red Blue Green Beige |
- SunBlox Roof & Shade Colors:**  
 White Red Royal Blue Laguna Blue Navy Blue Turquoise Rain Forest Terra Cotta Arizona Silver  
 Black Sunflower Yellow

**Play Palettes:**

- Blueberry Periwinkle Lemon Sunrise Botanical Tropics Forest Timber Earth Navy Dramatic  
 Salute Coast Field Brook Scenic Horizon Vista Celebrate Candy Centennial Sunshine  
 Moonlight Crimson