



State of West Virginia  
 Department of Administration  
 Purchasing Division  
 2019 Washington Street East  
 Post Office Box 50130  
 Charleston, WV 25305-0130

# Request for Quotation

RFQ NUMBER  
 DEP14156

PAGE  
 1

ADDRESS CORRESPONDENCE TO ATTENTION OF  
 CHUCK BOWMAN  
 304-558-2157

VENDOR

\*311144600 304-732-8303  
 PINEVILLE PAVING & EXCAVATING  
 PO BOX 1290  
 RT 10 SOUTH  
 PINEVILLE WV 24874

SHIP TO

ENVIRONMENTAL PROTECTION  
 DEPT. OF  
 OFFICE OF SPECIAL RECLAMATION  
 105 S. RAILROAD STREET  
 PHILIPPI, WV  
 26416-9998 304-457-3219

DATE PRINTED	TERMS OF SALE	SHIP VIA	F.O.B	FREIGHT TERMS
06/16/2009				

BID OPENING DATE: 06/24/2009 BID OPENING TIME 01:30PM

LINE	QUANTITY	UOP	CAT. NO.	ITEM NUMBER	UNIT PRICE	AMOUNT
***** ADDENDUM NO. 1 *****						
ADDENDUM ISSUED FOR THE BUFFALO COAL COMPANY PROJECT TO DISTRIBUTE THE PRE-BID SIGN-IN SHEETS AND THE Q/A RESULTING FROM THE 05/27/09 MANDATORY PRE-BID MEETING.						
BID OPENING DATE AND TIME REMAIN UNCHANGED AS 06/24/09 AT 1:30 PM.						
***** NO OTHER CHANGES *****						
0001	1	JB		962-73		
RECLAMATION: RESTORATION OF LAND					<i>Total</i>	<i>\$1,233,000.<sup>00</sup></i>

RECEIVED  
 2009 JUN 23 AM 9:57  
 WV PURCHASING DIVISION

SEE REVERSE SIDE FOR TERMS AND CONDITIONS

SIGNATURE *Kevin A. Bowland* TELEPHONE 304-732-8303 DATE 6-18-09  
 TITLE Vice President FEIN 550709824 ADDRESS CHANGES TO BE NOTED ABOVE

WHEN RESPONDING TO RFQ, INSERT NAME AND ADDRESS IN SPACE ABOVE LABELED 'VENDOR'

## GENERAL TERMS & CONDITIONS REQUEST FOR QUOTATION (RFQ) AND REQUEST FOR PROPOSAL (RFP)

1. Awards will be made in the best interest of the State of West Virginia.
2. The State may accept or reject in part, or in whole, any bid.
3. All quotations are governed by the **West Virginia Code** and the **Legislative Rules** of the Purchasing Division.
4. Prior to any award, the apparent successful vendor must be properly registered with the Purchasing Division and have paid the required \$125 fee.
5. All services performed or goods delivered under State Purchase Order/Contracts are to be continued for the term of the Purchase Order/Contracts, contingent upon funds being appropriated by the Legislature or otherwise being made available. In the event funds are not appropriated or otherwise available for these services or goods, this Purchase Order/Contract becomes void and of no effect after June 30.
6. Payment may only be made after the delivery and acceptance of goods or services.
7. Interest may be paid for late payment in accordance with the **West Virginia Code**.
8. Vendor preference will be granted upon written request in accordance with the **West Virginia Code**.
9. The State of West Virginia is exempt from federal and state taxes and will not pay or reimburse such taxes.
10. The Director of Purchasing may cancel any Purchase Order/Contract upon 30 days written notice to the seller.
11. The laws of the State of West Virginia and the **Legislative Rules** of the Purchasing Division shall govern all rights and duties under the Contract, including without limitation the validity of this Purchase Order/Contract.
12. Any reference to automatic renewal is hereby deleted. The Contract may be renewed only upon mutual written agreement of the parties.
13. **BANKRUPTCY:** In the event the vendor/contractor files for bankruptcy protection, the State may deem this contract null and void, and terminate such contract without further order.
14. **HIPAA BUSINESS ASSOCIATE ADDENDUM:** The West Virginia State Government HIPAA Business Associate Addendum (BAA), approved by the Attorney General, and available online at the Purchasing Division's web site (<http://www.state.wv.us/admin/purchase/vrc/hipaa.htm>) is hereby made part of the agreement. Provided that, the Agency meets the definition of a Cover Entity (45 CFR §160.103) and will be disclosing Protected Health Information (45 CFR §160.103) to the vendor.
15. **WEST VIRGINIA ALCOHOL & DRUG-FREE WORKPLACE ACT:** If this Contract constitutes a public improvement construction contract as set forth in Article 1D, Chapter 21 of the West Virginia Code ("The West Virginia Alcohol and Drug-Free Workplace Act"), then the following language shall hereby become part of this Contract: "The contractor and its subcontractors shall implement and maintain a written drug-free workplace policy in compliance with the West Virginia Alcohol and Drug-Free Workplace Act, as set forth in Article 1D, Chapter 21 of the West Virginia Code. The contractor and its subcontractors shall provide a sworn statement in writing, under the penalties of perjury, that they maintain a valid drug-free work place policy in compliance with the West Virginia and Drug-Free Workplace Act. It is understood and agreed that this Contract shall be cancelled by the awarding authority if the Contractor: 1) Fails to implement its drug-free workplace policy; 2) Fails to provide information regarding implementation of the contractor's drug-free workplace policy at the request of the public authority; or 3) Provides to the public authority false information regarding the contractor's drug-free workplace policy."

---

### INSTRUCTIONS TO BIDDERS

1. Use the quotation forms provided by the Purchasing Division.
2. **SPECIFICATIONS:** Items offered must be in compliance with the specifications. Any deviation from the specifications must be clearly indicated by the bidder. Alternates offered by the bidder as **EQUAL** to the specifications must be clearly defined. A bidder offering an alternate should attach complete specifications and literature to the bid. The Purchasing Division may waive minor deviations to specifications.
3. Complete all sections of the quotation form.
4. Unit prices shall prevail in case of discrepancy.
5. All quotations are considered F.O.B. destination unless alternate shipping terms are clearly identified in the quotation.
6. **BID SUBMISSION:** All quotations must be delivered by the bidder to the office listed below prior to the date and time of the bid opening. Failure of the bidder to deliver the quotations on time will result in bid disqualifications: Department of Administration, Purchasing Division, 2019 Washington Street East, P.O. Box 50130, Charleston, WV 25305-0130

**Addendum #1 - Questions During Pre-Bid Conference  
For DEP 14156  
Buffalo Coal Company, Inc. Permit # S-2003-03**

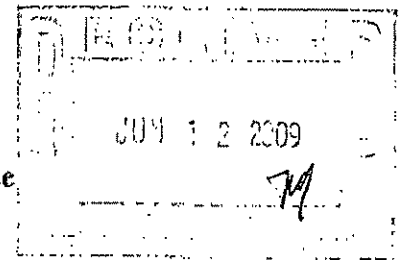

The following questions were identified at the Pre Bid Conference (PBC). The answers provided herein take precedence over verbal answers at the PBC should there be any conflicts between the two.

- 1.) Q. Item 6.0, liming, what type of lime do you want? Is it required for pit dewatering, or treating continuously throughout after dewatering is over, do we have to monitor that (water quality)? Is it going to cover up spoil (backfilling) or going to treat the water?  
A. The lime in the backfill will be the same as the agricultural lime for revegetation. It's not for water treatment, it's for liming the pit and/or creating a pad for toxic material. If we don't find toxic material on the pit floor after it's been dewatered, we're going to use it in the subsurface. We plan to use the whole amount here on the job as an alkalinity amendment.
- 2.) Q. Are we going to treat the water as we dewater the pits?  
A. Yes, that's under pit dewatering. Water treatment is incidental to pit dewatering.
- 3.) Q. Will that second gate need to stay closed all the time?  
A. Yes, both gates need to be closed and locked, in and out at all times.
- 4.) Q. Is water treatment incidental to pit dewatering?  
A. Yes.
- 5.) Q. What is the current pH of the pit water?  
A. About 4 or 5, but it's not real high in metals, not a real hard treat.
- 6.) Q. When you say agricultural lime, you're not meaning limestone sands, you're meaning burnt lime?  
A. Under bid item 9.1: Unless otherwise specified, all lime used shall be registered with the WV Dept. of Agriculture, have an 85% minimum calcium carbonate equivalent, and meet the fineness classification no larger than for ground lime. The following fineness classifications or combinations of lime are acceptable: See chart for sieve passing percentages for pulverized and ground lime. For the revegetation line item, lime is to be spread at 5 tons/acre, but we'll do 40 tons/acre in the backfilling for alkaline amendment. Clarification: Not burnt lime.
- 7.) Q. On the previous statement you made on backfilling acreage (a lump sum item), you're saying the pit areas equal approximately 19 acres. If it's more than that, can we bring it to your attention after the fact?  
A. No, the actual areas and volumes are up to the contractor to determine. 19 acres is a rough estimate. The acreage doesn't matter to us, it's a lump sum bid item, however you bid it is how much you'll get paid for completing it.

- 8.) Q. If it's more than 19 acres, do we just stop at 19 acres?  
 A. No, you do whatever it takes; if it's 30 acres you do it. We're not paying anything different, it's a lump sum bid item. Individually, it's up to the contractor to come out here and verify it. We're not negotiating anything this time (no 20% over/under), it's going to be up to the contractor to verify areas and volumes.
  
- 9.) Q. (Directed towards statement of needing approval for more work on regrading and topsoiling) Do we need approval to go after more material for backfilling? We have to do everything that's exposed, there's no need for permission to go after material on the backfilling lump sum item?  
 A. That's correct, but we don't want to touch anything that's not disturbed, keep to the permit boundaries. That's why on the site map we talk about going from site reference point A to point B. After we get through the spoil material that's closest to pit area 1 done, you're going to have to start going out where they took all this material out on the old haulroad. We want that material brought in to backfill these pits. Anything left over we're just going to regrade in place. Clarification: We expect there to be enough spoil material to complete the backfilling without needing to dig below the approximate original contour.
  
- 10.) Q. (In reference to regrading the old haulroad in place) Is it all going to drain towards that ditch (between access road and spoil area A), or are we going to crown it?  
 A. We'll crown it; it'll go off both ways. On the map, we have all the V-ditches routed into the sediment control structure, so in the case that the water is still bad, we can eventually treat it.
  
- 11.) Q. (In reference to original grade above pit area 1, on the south/southwest side) Is that where the finished grade will be?  
 A. That will be your finished grade there, and it tapers out into a big bowl, with the center between the two pits. Get everything to drain towards the center where the sediment control pond is.
  
- 12.) Q. Have you made any calculations as to total cubic yards in all this that have to be moved?  
 A. No, that's up to the contractor.
  
- 13.) Q. (At pit 1, in reference to the two parts of pit 1) Is this water (large pit pool) going through this rock into this (smaller pool to the northeast)? Is it all just level?  
 A. We think you're getting drainage from over here (above the pit to the northwest) on around (behind the central spoil pile).
  
- 14.) Q. (At pit 1) Is pit 2 draining this way too?  
 A. No, the low point is over there (between the two pits).
  
- 15.) Q. (At final outflow culvert) Does anything happen on the outfall of this pipe?  
 A. We've got some trapezoidal ditch and V-ditch. If anything we might use some trapezoidal ditch to redo a little bit, but we didn't have planned to go down through there very far. We plan to use that (trapezoidal ditch?).

- 16.) Q. (Standing at the 36 inch road culvert) This is the final discharge?  
A. Yes.
- 17.) Q. (Pointing up to the north of pit 2) That area up there, is that included in the revegetation, where it's clear and grubbed?  
A. Yes, up to the tree line and back to where it comes up this way. You can see a dark green area to the left, then you see where it gets to the more disturbed areas. If it's not been disturbed much and there's good vegetation on it, you might not have to do anything on those areas. So it's going to be more of the lower part of it here where the pit is, this section down to the haulroad is where we're focusing.
- 18.) Q. What about the topsoil, if there's not a lot of topsoil on site?  
A. You'll have to use the best available material. Stockpile the best that we have.
- 19.) Q. Concerning the year warranty on the seed, as far as coming back if you're wanting to do more reforestation, how are you going to deal with that? What about seeing a lot of bare spots? What if we have to come back?  
A. Reforestation is why we're doing a light vegetation, light seeding, fertilizing and liming. We're shooting for a light vegetation here, but if we've got big bare areas, you're going to have to come back.
- 20.) Q. If it's still as spotty as it is up there, is that going to be good enough?  
A. Yes, probably. We don't want to get the soil all limed up, we want an acidic soil for future tree vegetation, so you're going to have some spotty vegetation.
- 21.) Q. As far as you said mixing in the brush and roots that are piled up, it can all just be mixed?  
A. Just bring it back in, yes. That was the intent. We can utilize those stockpiles of brush that can actually be placed back in.
- 22.) Q. What about surface conditions when we're finished, with big rocks sticking up and whatnot?  
A. These sites are rough as a cob when you're done, if there are rocks sticking up, no big deal.
- 23.) Q. Could you go over the tree species for this planting, are they listed in there?  
A. No, that's a separate contract that will be done next spring.
- 24.) Q. They're going to do that the following year?  
A. We're hoping if this job's done by winter, next spring is when we'll plant. If it's not done in time, we'll have to wait until the next spring.
- 25.) Q. You're not going to plant trees if we're still working right?  
A. No, if you're still working, we aren't going to do the trees. But we may come in if you've got a section done, and do that. It's to our benefit to get the vegetation in as quick as possible.

- 26.) Q. You said to pump this pond (pit 2) back out after we pumped that pond (pit 1) into it, do you pump it into here (final pond)?  
A. Yes. Once you're down to this, you're not going to have a lot of water to treat. That's the intent, to keep going from big areas to smaller areas (of water), but hopefully we'll get some sediment control and settling out of that final pond, so we're not discharging turbid water.
- 27.) Q. On the water treatment, we're responsible for treatment when we're pumping in here and it's discharging, is that the only time?  
A. Yes. And of course, we have to keep the pits dewatered when you're backfilling.
- 28.) Q. If we pump the pits down, and there's discharge not due to us pumping, are we responsible for that? How long are we responsible for treatment? Through the warranty period, or just when we're pumping?  
A. No, no treatment during times it's discharging without you pumping, you only need to treat while you're pumping.
- 29.) Q. So normal flow, like right now, we wouldn't be treating?  
A. Right. We have our own treatment that may be set up to kick in and help treat at those times. But we're not taking the responsibility to treat while it's being pumped.
- 30.) Q. (At the wetlands between the haulroads) Does anything happen here?  
A. No, we hope to leave everything approximately the same there, we don't want to dewater that, it's an existing wetland. Clarification: a new 24" culvert for the outflow of that wetland (bid item 15.0) will be placed by the contractor. All efforts shall be made to minimize impact to the wetland during culvert placement and regrading the access road.
- 31.) Q. Are you going to have another date set up (to survey the site)?  
A. Yes, we'll get a couple dates set up to come out and see things (call Brad Moore, 304-203-4051 or call David McCoy, 304-203-2921).

# MANDATORY PRE-BID SIGN-IN ATTENDANCE SHEET

RFQ # : DEP14156  
 Project: Buffalo Coal Company  
 Permit # S-2003-03

Bid Date: 6/24/09  
 Pre-Bid Date: 5/27/09

~~Name : \_\_\_\_\_  
 Company: \_\_\_\_\_  
 Address: \_\_\_\_\_  
 Phone #: \_\_\_\_\_  
 Fax #: \_\_\_\_\_  
 Email : \_\_\_\_\_~~

Name : Jason Rohr  
 Company: Rohrco Corp  
 Address: 154 Clarksburg Rd  
Buckhannon WV 26201  
 Phone# : 304 472 4790  
 Fax # : 304 472 3949  
 Email : jasonrohrco@yahoo.com

Name : RALPH MILLER  
 Company: ROHRCO CORP  
 Address: 154 CLARKSBURG RD  
BUCKHANNON, WV  
26201  
 Phone # : 304-472-4790  
 Fax # : 304-472-3949  
 Email : ralphm@msw.com

Name : WAYNE H. STANLEY  
 Company: STANLEY INDUSTRIES, INC  
 Address: 7 Maple Lake  
Bridgeport, WV 26330  
 Phone# : 304-842-8560  
 Fax # : 304-842-8609  
 Email : GSTANLEY@Ma. ILL. COM

Name : DAVID H. BOWMAN  
 Company: GREEN MOUNTAIN CO.  
 Address: 511 50TH STREET  
CHAS. WV  
25304  
 Phone # : 304-925-0253  
 Fax # : 925-9230  
 Email : Jody Mayer AOL.com

Name : JAMIE Pritzol  
 Company: J.L. Pritzol Contracting  
 Address: 9 Belgian Est.  
Burketon Mills WV 26525  
 Phone# : 304-379-7789  
 Fax # : 304-379-7788  
 Email : pritzol@AOL.com

Name : Matt Evans  
 Company: PE Contracting Inc  
 Address: Charlesburg WV

Name : Jeff Brumfield  
 Company: Mountaineer Grading  
 Address: 159 Elkview  
WV 25071

Phone # : 620-2400  
 Fax # : 620-2400  
 Email : \_\_\_\_\_

Phone# : 304-548-6800  
 Fax # : 304-548-6900  
 Email : Jeff.Brumbfield@mountaineergrading.com

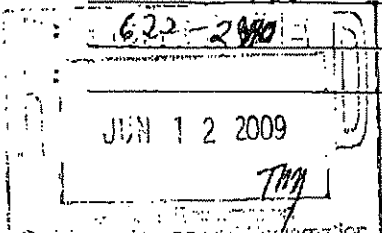

# MANDATORY PRE-BID SIGN-IN ATTENDANCE SHEET

RFQ # : DEP14156 Bid Date: 6/24/09  
 Project: Buffalo Coal Company Pre-Bid Date: 5/27/09  
 Permit # S-2003-03

Name : James Nelson  
 Company: Nelson Limited  
 Address: PO Box 298 Thomas  
304 463 4313  
Fax 304 463 4311  
 Phone #: \_\_\_\_\_  
 Fax # : \_\_\_\_\_  
 Email : \_\_\_\_\_

Name : JAMES ALLEN  
 Company: JF Allen Co  
 Address: P.O. Box 2049  
Beckham WV 26201  
 Phone# : 304 472 8890  
 Fax # : 304 472 8897  
 Email : \_\_\_\_\_

Name : Ann Wardwell  
 Company: EASTERN ATROX  
 Address: PO Box 4108  
CHARLESTON WV  
25364  
 Phone # : 304. 414. 0255  
 Fax # : 0256  
 Email : \_\_\_\_\_

Name : RAY RICE  
 Company: SHAMROCK ENV. CORP.  
 Address: 6106 CORPORATE PARK DR.  
BROWNS SUMMIT, NC  
27214  
 Phone# : (336) 207-4034  
 Fax # : \_\_\_\_\_  
 Email : RRICE@SHAMROCKENVRO.COM

Name : Angie L. Collins Jr.  
 Company: Collins Building & Contracting Inc.  
 Address: 3426 Corley - Conroy Rd.  
Flintknob WV 26021  
 Phone # : 704-765-3521  
 Fax # : same  
 Email : Collins Building & Contracting, Inc.

Name : JAMES BUCKLAND  
 Company: B B TRANSIT INC  
 Address: 720 Beaman WV  
 Phone# : 304 292 4903  
 Fax # : 304 253 4533  
 Email : bb Transit - net

Name : Robert Barnes  
 Company: Barnes EXC. INC.  
 Address: P.O. Box 13384  
Sissonville WV  
25360  
 Phone # : 304-984-7725  
 Fax # : 304-984-0074  
 Email : none

Name : Steve Jurasko  
 Company: Polino Contracting Inc.  
 Address: PO Box 230  
Elkins WV 26241  
 Phone# : 304 636-3886  
 Fax # : 304 636-5108  
 Email : STurasko@Polino.com



# MANDATORY PRE-BID SIGN-IN ATTENDANCE SHEET

RFQ # : DEP14156  
 Project: Buffalo Coal Company  
 Permit # S-2003-03

Bid Date: 6/24/09  
 Pre-Bid Date: 5/27/09

Name : THOMAS HART  
 Company: LEXINGTON MALL RECREATION  
 Address: MARLBOROUGH WV

Phone #: 304-949-2372  
 Fax #: 304-949-2395  
 Email : thart@LEXINGTONCOAL  
COM

Name : BRIAN SCARFNER  
 Company: BYCO ENT.  
 Address: 11746 BITINGER RD  
GRANTSVILLE MD 21536

Phone #: 301 245-4322  
 Fax #: 301 245-4364  
 Email : bwsbyco@aol.com

Name : Wade Hooser  
 Company: Honey Hill Corp  
 Address: 5544 Stemple Rd  
26705

Phone #: (304) 755-5465  
 Fax # : \_\_\_\_\_  
 Email : \_\_\_\_\_

Name : Ronald Phoros  
 Company: R'S construction  
 Address: PO Box 142  
Circleville WV

Phone #: 304-567-2634  
 Fax # : \_\_\_\_\_  
 Email : \_\_\_\_\_

Name : Kerir Bradford  
 Company: Pineville Paving & Excavating Inc  
 Address: P.O. Box 1290  
Pineville WV 24874

Phone#: 304-732-8303  
 Fax # : 304-732-7855  
 Email : \_\_\_\_\_

Name : ALL Construction Inc  
 Company: Jason Kitzmiller  
 Address: PO Box 92  
MT. STORM WV 26737

Phone#: 304-693-7131  
 Fax # : 304-693-7199  
 Email : Kitzmillertjason@msw.com

Name : Charles H Moyers  
 Company: Bruceston Ag Service  
 Address: PO Box 107  
Bruceston mills WV  
26575

Phone#: 304-379-2641  
 Fax # : 304-379-2645  
 Email : charlie.moyers@sscoop.com

Name : Tina Winters  
 Company: Eglen Farm Service  
 Address: 55 main street  
Eglen WV 26716

Phone#: 304-735-3761  
 Fax # : 304-735-3762  
 Email : tina.winters@sscoop.com  
cell 304-216-5113

# MANDATORY PRE-BID SIGN-IN ATTENDANCE SHEET

RFQ # : DEP14156 Bid Date: 6/24/09  
 Project: Buffalo Coal-Company Pre-Bid Date: 5/27/09  
 Permit # S-2003-03

Name : Spencer Woodell  
 Company: Cowgirl Up Inc  
 Address: PO Box 243  
Simpson WVa  
26435  
 Phone #: 304-739-4897  
 Fax #: 304-739-4401  
 Email : scw.cowgirlup@gmail.com

Name : ~~\_\_\_\_\_~~  
 Company: ~~\_\_\_\_\_~~  
 Address: ~~\_\_\_\_\_~~  
 Phone#: ~~\_\_\_\_\_~~  
 Fax #: ~~\_\_\_\_\_~~  
 Email : ~~\_\_\_\_\_~~

Name : ~~\_\_\_\_\_~~  
 Company: ~~\_\_\_\_\_~~  
 Address: ~~\_\_\_\_\_~~  
 Phone #: ~~\_\_\_\_\_~~  
 Fax #: ~~\_\_\_\_\_~~  
 Email : ~~\_\_\_\_\_~~

Name : ~~\_\_\_\_\_~~  
 Company: ~~\_\_\_\_\_~~  
 Address: ~~\_\_\_\_\_~~  
 Phone#: ~~\_\_\_\_\_~~  
 Fax #: ~~\_\_\_\_\_~~  
 Email : ~~\_\_\_\_\_~~

Name : ~~\_\_\_\_\_~~  
 Company: ~~\_\_\_\_\_~~  
 Address: ~~\_\_\_\_\_~~  
 Phone #: ~~\_\_\_\_\_~~  
 Fax #: ~~\_\_\_\_\_~~  
 Email : ~~\_\_\_\_\_~~

Name : ~~\_\_\_\_\_~~  
 Company: ~~\_\_\_\_\_~~  
 Address: ~~\_\_\_\_\_~~  
 Phone#: ~~\_\_\_\_\_~~  
 Fax #: ~~\_\_\_\_\_~~  
 Email : ~~\_\_\_\_\_~~

Name : ~~\_\_\_\_\_~~  
 Company: ~~\_\_\_\_\_~~  
 Address: ~~\_\_\_\_\_~~  
 Phone #: ~~\_\_\_\_\_~~  
 Fax #: ~~\_\_\_\_\_~~  
 Email : ~~\_\_\_\_\_~~

5-27-09  
 Name : David McCoy  
 Company: WV DEP  
 Address: Philippi, WV  
 Phone#: 304-457-3219  
 Fax #: \_\_\_\_\_  
 Email : \_\_\_\_\_



State of West Virginia  
 Department of Administration  
 Purchasing Division  
 2019 Washington Street East  
 Post Office Box 50130  
 Charleston, WV 25305-0130

# Request for Quotation

RFQ NUMBER
DEP14156

PAGE
1

ADDRESS CORRESPONDENCE TO ATTENTION OF
CHUCK BOWMAN 304-558-2157

\*311144600 304-732-8303  
 PINEVILLE PAVING & EXCAVATING  
 PO BOX 1290  
 RT 10 SOUTH  
 PINEVILLE WV 24874

ENVIRONMENTAL PROTECTION  
 DEPT. OF  
 OFFICE OF SPECIAL RECLAMATION  
 105 S. RAILROAD STREET  
 PHILIPPI, WV  
 26416-9998 304-457-3219

DATE PRINTED	TERMS OF SALE	SHIP VIA	F.O.B	FREIGHT TERMS
05/07/2009				

BID OPENING DATE: 06/24/2009 BID OPENING TIME 01:30PM

LINE	QUANTITY	UOP	CAT. NO.	ITEM NUMBER	UNIT PRICE	AMOUNT
0001	1	JB		962-73		
<p>RECLAMATION: RESTORATION OF LAND</p> <p>THE WEST VIRGINIA PURCHASING DIVISION, FOR THE AGENCY, THE WEST VIRGINIA DEPARTMENT OF ENVIRONMENTAL PROTECTION'S OFFICE OF SPECIAL RECLAMATION, IS SOLICITING QUALIFIED CONTRACTORS FOR A CONTRACT TO PROVIDE ALL LABOR AND MATERIALS TO PERFORM RECLAMATION ON THE MINING OPERATION OF BUFFALO COAL COMPANY, INC., NOW UNDER REVOKED PERMIT NUMBER(S) S-2003-03, ON A SITE CONSISTING OF APPROXIMATELY 60 ACRES LOCATED NEAR MOUNT STORM, WV, (GRANT CO.).</p> <p>THE RECLAMATION SHALL BE PERFORMED UNDER THE GUIDANCE AND GENERAL SUPERVISION OF THE AGENT ASSIGNED TO THE PROJECT FOR THE STATE OF WEST VIRGINIA, DEPARTMENT OF ENVIRONMENTAL PROTECTION.</p> <p>A MANDATORY ON-SITE PREBID CONFERENCE WILL BE HELD ON 05/27/2009 @ 10:00 AM. FAILURE TO ATTEND THE PREBID CONFERENCE WILL RESULT IN BID DISQUALIFICATION.</p> <p>DIRECTIONS TO PREBID: IN TUCKER CO., FROM THE INTERSECTION OF STATE RT 32 AND 93 NEAR DAVIS, GO 11.5 MILES EAST ON RT 93 TO THE TUCKER/GRANT CO. LINE. JUST PAST THE CAUTION LIGHT, TURN RIGHT ONTO A GATED HAULROAD. THE SITE IS 5.5 MILES OUT THIS ROAD.</p> <p>ALL WORK MUST BE COMPLETED IN ACCORDANCE WITH THE PLANS AND SPECIFICATIONS PREPARED BY THE DEPARTMENT OF ENVIRONMENTAL PROTECTION AND PURCHASE ORDER ISSUED</p>						

SEE REVERSE SIDE FOR TERMS AND CONDITIONS

SIGNATURE <i>Kevin A. Bunch</i>	TELEPHONE 304-732-8303	DATE 6-18-09
TITLE Vice President	FEIN 550709801	ADDRESS CHANGES TO BE NOTED ABOVE

WHEN RESPONDING TO RFQ, INSERT NAME AND ADDRESS IN SPACE ABOVE LABELED 'VENDOR'



State of West Virginia  
 Department of Administration  
 Purchasing Division  
 2019 Washington Street East  
 Post Office Box 50130  
 Charleston, WV 25305-0130

# Request for Quotation

RFQ NUMBER
DEP14156

PAGE
2

ADDRESS CORRESPONDENCE TO ATTENTION OF
CHUCK BOWMAN 304-558-2157

\*311144600 304-732-8303  
 PINEVILLE PAVING & EXCAVATING  
 PO BOX 1290  
 RT 10 SOUTH  
 PINEVILLE WV 24874

ENVIRONMENTAL PROTECTION  
 DEPT. OF  
 OFFICE OF SPECIAL RECLAMATION  
 105 S. RAILROAD STREET  
 PHILIPPI, WV  
 26416-9998 304-457-3219

DATE PRINTED	TERMS OF SALE	SHIP VIA	F.O.B.	FREIGHT TERMS
05/07/2009				

BID OPENING DATE: 06/24/2009 BID OPENING TIME 01:30PM

LINE	QUANTITY	UOP	CAT NO.	ITEM NUMBER	UNIT PRICE	AMOUNT
<p>BY THE DEPARTMENT OF ADMINISTRATION, DIVISION OF PURCHASING.</p> <p>EXHIBIT 5</p> <p>WEST VIRGINIA CODE 21-1D-5 PROVIDES THAT: ANY SOLICITATION FOR A PUBLIC IMPROVEMENT CONSTRUCTION CONTRACT REQUIRES EACH VENDOR THAT SUBMITS A BID FOR THE WORK TO SUBMIT AT THE SAME TIME AN AFFIDAVIT OF COMPLIANCE WITH THE BID. THE ENCLOSED PURCHASING AFFIDAVIT MUST BE SIGNED AND SUBMITTED WITH THE BID AS EVIDENCE OF THE VENDOR'S COMPLIANCE WITH THE PROVISIONS OF ARTICLE 1D, CHAPTER 21 OF THE WEST VIRGINIA CODE. FAILURE TO SUBMIT THE SIGNED PURCHASING AFFIDAVIT WITH THE BID SHALL RESULT IN DISQUALIFICATION OF SUCH BID.</p> <p>NOTICE TO PROCEED: THIS CONTRACT IS TO BE PERFORMED WITH 365 CALENDAR DAYS AFTER THE NOTICE TO PROCEED IS RECEIVED. UNLESS OTHERWISE SPECIFIED, THE FULLY EXECUTED PURCHASE ORDER WILL BE CONSIDERED NOTICE TO PROCEED.</p> <p>CANCELLATION: THE DIRECTOR OF PURCHASING RESERVES THE RIGHT TO CANCEL THIS CONTRACT IMMEDIATELY UPON WRITTEN NOTICE TO THE VENDOR IF THE MATERIALS OR WORKMANSHIP SUPPLIED ARE OF AN INFERIOR QUALITY OR DO NOT CONFORM WITH THE SPECIFICATIONS OF THE THE BID AND CONTRACT HERE IN.</p> <p>WAGE RATES: THE CONTRACTOR OR SUBCONTRACTOR SHALL PAY THE HIGHER OF THE U.S. DEPARTMENT OF LABOR MINIMUM WAGE RATES AS ESTABLISHED FOR GRANT COUNTY, PURSUANT TO WEST VIRGINIA CODE 21-5A, ET, SEQ. (PREVAILING WAGE RATES APPLY TO THIS PROJECT)</p>						

SIGNATURE <i>Kenn D. Beall</i>		SEE REVERSE SIDE FOR TERMS AND CONDITIONS		TELEPHONE	DATE <i>6-18-09</i>
TITLE <i>V. Pres.</i>	FEIN	ADDRESS CHANGES TO BE NOTED ABOVE			

WHEN RESPONDING TO RFQ, INSERT NAME AND ADDRESS IN SPACE ABOVE LABELED 'VENDOR'



State of West Virginia  
 Department of Administration  
 Purchasing Division  
 2019 Washington Street East  
 Post Office Box 50130  
 Charleston, WV 25305-0130

# Request for Quotation

RFQ NUMBER
DEP14156

PAGE
4

ADDRESS CORRESPONDENCE TO ATTENTION OF
CHUCK BOWMAN 304-558-2157

VENDOR

\*311144600      304-732-8303  
 PINEVILLE PAVING & EXCAVATING  
 PO BOX 1290  
 RT 10 SOUTH  
 PINEVILLE WV 24874

SHIP TO

ENVIRONMENTAL PROTECTION  
 DEPT. OF  
 OFFICE OF SPECIAL RECLAMATION  
 105 S. RAILROAD STREET  
 PHILIPPI, WV  
 26416-9998      304-457-3219

DATE PRINTED	TERMS OF SALE	SHIP VIA	F.O.B.	FREIGHT TERMS
05/07/2009				

BID OPENING DATE: **06/24/2009**      BID OPENING TIME **01:30PM**

LINE	QUANTITY	UOP	CAT. NO.	ITEM NUMBER	UNIT PRICE	AMOUNT
<p>( ) MAINTENANCE BOND: A TWO (2) YEAR MAINTENANCE BOND COVERING THE ROOFING SYSTEM WILL BE A REQUIREMENT OF THE SUCCESSFUL VENDOR.</p> <p>REV. 11/00</p> <p>CONTRACTORS LICENSE</p> <p>WEST VIRGINIA STATE CODE 21-11-2 REQUIRES THAT ALL PERSONS DESIRING TO PERFORM CONTRACTING WORK IN THIS STATE MUST BE LICENSED. THE WEST VIRGINIA CONTRACTORS LICENSING BOARD IS EMPOWERED TO ISSUE THE CONTRACTORS LICENSE. APPLICATIONS FOR A CONTRACTORS LICENSE MAY BE MADE BY CONTACTING THE WEST VIRGINIA DIVISION OF LABOR CAPITOL COMPLEX, BUILDING 3, ROOM 319, CHARLESTON, WV 25305. TELEPHONE: (304) 558-7890.</p> <p>WEST VIRGINIA STATE CODE 21-11-11 REQUIRES ANY PROSPECTIVE BIDDER TO INCLUDE THE CONTRACTORS LICENSE NUMBER ON THEIR BID.</p> <p>BIDDER TO COMPLETE: <i>Pineville Paving &amp; Excavating, Inc.</i>          CONTRACTORS NAME: ..<i>Pineville Paving &amp; Excavating, Inc.</i>.....</p> <p>CONTRACTORS LICENSE NO.: ..<i>WV010542</i>.....</p> <p>THE SUCCESSFUL BIDDER WILL BE REQUIRED TO FURNISH A COPY OF THEIR CONTRACTORS LICENSE PRIOR TO ISSUANCE OF A PURCHASE ORDER/CONTRACT.</p> <p>APPLICABLE LAW</p> <p>THE WEST VIRGINIA STATE CODE, PURCHASING DIVISION RULES AND REGULATIONS, AND THE INFORMATION PROVIDED IN THE "REQUEST FOR QUOTATION" ISSUED BY THE PURCHASING</p>						

SEE REVERSE SIDE FOR TERMS AND CONDITIONS		
SIGNATURE <i>Kevin D. Bradford</i>	TELEPHONE	DATE <i>6-18-09</i>
TITLE <i>V. Pres.</i>	ADDRESS CHANGES TO BE NOTED ABOVE	

WHEN RESPONDING TO RFQ, INSERT NAME AND ADDRESS IN SPACE ABOVE LABELED 'VENDOR'



State of West Virginia  
 Department of Administration  
 Purchasing Division  
 2019 Washington Street East  
 Post Office Box 50130  
 Charleston, WV 25305-0130

# Request for Quotation

RFQ NUMBER  
**DEP14156**

PAGE  
**5**

ADDRESS CORRESPONDENCE TO ATTENTION OF  
**CHUCK BOWMAN**  
**304-558-2157**

P U R C H A S I N G

\*311144600      304-732-8303  
**PINEVILLE PAVING & EXCAVATING**  
**PO BOX 1290**  
**RT 10 SOUTH**  
**PINEVILLE WV 24874**

S H I P T O

**ENVIRONMENTAL PROTECTION**  
**DEPT. OF**  
**OFFICE OF SPECIAL RECLAMATION**  
**105 S. RAILROAD STREET**  
**PHILIPPI, WV**  
**26416-9998      304-457-3219**

DATE PRINTED <b>05/07/2009</b>	TERMS OF SALE	SHIP VIA	F.O.B.	FREIGHT TERMS
-----------------------------------	---------------	----------	--------	---------------

BID OPENING DATE: **06/24/2009**      BID OPENING TIME **01:30PM**

LINE	QUANTITY	UOP	CAT NO	ITEM NUMBER	UNIT PRICE	AMOUNT
<p><b>DIVISION IS THE SOLE AUTHORITY GOVERNING THIS PROCUREMENT.</b></p> <p><b>ANY INFORMATION PROVIDED IN SPECIFICATION MANUALS, OR ANY OTHER SOURCE, VERBAL OR WRITTEN, WHICH CONTRADICTS OR ALTERS THE INFORMATION PROVIDED FROM THE SOURCES AS DESCRIBED IN THE ABOVE PARAGRAPH IS VOID AND OF NO EFFECT.</b></p> <p><b>BANKRUPTCY: IN THE EVENT THE VENDOR/CONTRACTOR FILES FOR BANKRUPTCY PROTECTION, THIS CONTRACT IS AUTOMATICALLY NULL AND VOID, AND IS TERMINATED WITHOUT FURTHER ORDER.</b></p> <p><b>PREFERENCE FOR USE OF DOMESTIC STEEL PRODUCTS</b></p> <p><b>1. EXCEPT WHEN AUTHORIZED BY THE DIRECTOR OF THE PURCHASING DIVISION PURSUANT TO SUBSECTION 2 BELOW NO CONTRACTOR MAY USE OR SUPPLY STEEL PRODUCTS FOR A STATE CONTRACT PROJECT OTHER THAN THOSE STEEL PRODUCTS MADE IN THE UNITED STATES. AS USED USED IN THIS CONTRACT,</b></p> <p><b>A. "STATE CONTRACT PROJECT" MEANS ANY ERECTION OR CONSTRUCTION OF, OR ANY ADDITION TO, ALTERATION OF OR OTHER IMPROVEMENT TO ANY BUILDING OR STRUCTURE, INCLUDING, BUT NOT LIMITED TO, ROADS OR HIGHWAYS, OR THE INSTALLATION OF ANY HEATING OR COOLING OR VENTILATING PLANTS OR OTHER EQUIPMENT, OR THE SUPPLY OF AND MATERIALS FOR SUCH PROJECTS, PURSUANT TO A CONTRACT WITH THE STATE OF WEST VIRGINIA FOR WHICH BIDS WERE SOLICITED ON OR AFTER JUNE 6, 2001.</b></p> <p><b>B. "STEEL PRODUCTS" MEANS PRODUCTS ROLLED, FORMED, SHAPED, DRAWN, EXTRUDED, FORGED, CAST,</b></p>						

SEE REVERSE SIDE FOR TERMS AND CONDITIONS

SIGNATURE <i>Kari O. Bugh</i>	TELEPHONE	DATE <b>6-18-09</b>
TITLE <i>V. Pres.</i>	ADDRESS CHANGES TO BE NOTED ABOVE	

WHEN RESPONDING TO RFQ, INSERT NAME AND ADDRESS IN SPACE ABOVE LABELED 'VENDOR'



State of West Virginia  
 Department of Administration  
 Purchasing Division  
 2019 Washington Street East  
 Post Office Box 50130  
 Charleston, WV 25305-0130

# Request for Quotation

RFQ NUMBER
DEP14156

PAGE
6

ADDRESS CORRESPONDENCE TO ATTENTION OF
CHUCK BOWMAN 304-558-2157

VENDOR

\*311144600 304-732-8303  
 PINEVILLE PAVING & EXCAVATING  
 PO BOX 1290  
 RT 10 SOUTH  
 PINEVILLE WV 24874

SHIP TO

ENVIRONMENTAL PROTECTION  
 DEPT. OF  
 OFFICE OF SPECIAL RECLAMATION  
 105 S. RAILROAD STREET  
 PHILIPPI, WV  
 26416-9998 304-457-3219

DATE PRINTED	TERMS OF SALE	SHIP VIA	F.O.B.	FREIGHT TERMS
05/07/2009				

BID OPENING DATE: 06/24/2009 BID OPENING TIME 01:30PM

LINE	QUANTITY	UOP	CAT NO	ITEM NUMBER	UNIT PRICE	AMOUNT
				FABRICATED OR OTHERWISE SIMILARLY PROCESSED, OR PROCESSED BY A COMBINATION OF TWO OR MORE OF SUCH OPERATIONS, FROM STEEL MADE BY THE OPEN HEARTH, BASIC OXYGEN, ELECTRIC FURNACE, BESSEMER OR OTHER STEEL MAKING PROCESS.		
				C. "UNITED STATES" MEANS THE UNITED STATES OF AMERICA AND INCLUDES ALL TERRITORY, CONTINENTAL OR INSULAR, SUBJECT TO THE JURISDICTION OF THE UNITED STATES.		
				2. THE DIRECTOR OF THE PURCHASING DIVISION MAY, IN WRITING, AUTHORIZE THE USE OF FOREIGN STEEL PRODUCTS IF:		
				A. THE COST FOR EACH CONTRACT ITEM USED DOES NOT EXCEED ONE TENTH OF ONE PERCENT (.1%) OF THE TOTAL CONTRACT COST OR TWO THOUSAND FIVE HUNDRED DOLLARS (2,500.00), WHICHEVER IS GREATER. FOR THE PURPOSES OF THIS SECTION, THE COST IS THE VALUE OF THE STEEL PRODUCT AS DELIVERED TO THE PROJECT OR,		
				B. THE DIRECTOR OF THE PURCHASING DIVISION DETERMINES THAT SPECIFIED STEEL MATERIALS ARE NOT PRODUCED IN THE UNITED STATES IN SUFFICIENT QUANTITY OR OTHERWISE ARE NOT REASONABLY AVAILABLE TO MEET CONTRACT REQUIREMENTS.		
				3. A CONTRACTOR WHO USES STEEL PRODUCTS IN VIOLATION OF THIS SECTION MAY BE SUBJECT TO CIVIL PENALTIES PURSUANT TO WV CODE SECTION 5A-3-56.		
				REV. 10/01/01		

SEE REVERSE SIDE FOR TERMS AND CONDITIONS

SIGNATURE	TELEPHONE	DATE
<i>Karin D. Broughal</i>		6-18-09
TITLE	ADDRESS CHANGES TO BE NOTED ABOVE	
V. Pres.		

WHEN RESPONDING TO RFQ, INSERT NAME AND ADDRESS IN SPACE ABOVE LABELED 'VENDOR'



State of West Virginia  
 Department of Administration  
 Purchasing Division  
 2019 Washington Street East  
 Post Office Box 50130  
 Charleston, WV 25305-0130

# Request for Quotation

RFQ NUMBER
DEP14156

PAGE
7

ADDRESS CORRESPONDENCE TO ATTENTION OF:
CHUCK BOWMAN 304-558-2157

VENDOR

\*311144600      304-732-8303  
 PINEVILLE PAVING & EXCAVATING  
 PO BOX 1290  
 RT 10 SOUTH  
 PINEVILLE WV 24874

SHIP TO

ENVIRONMENTAL PROTECTION  
 DEPT. OF  
 OFFICE OF SPECIAL RECLAMATION  
 105 S. RAILROAD STREET  
 PHILIPPI, WV  
 26416-9998      304-457-3219

DATE PRINTED	TERMS OF SALE	SHIP VIA	F.O.B.	FREIGHT TERMS
05/07/2009				

BID OPENING DATE: **06/24/2009**      BID OPENING TIME **01:30PM**

LINE	QUANTITY	UOP	CAT NO.	ITEM NUMBER	UNIT PRICE	AMOUNT
				<p><b>EXHIBIT 7</b></p> <p><b>DOMESTIC ALUMINUM, GLASS &amp; STEEL IN PUBLIC WORKS PROJECTS</b></p> <p>IN ACCORDANCE WITH WEST VIRGINIA CODE 5-19-1 ET., SEQ., EVERY CONTRACT FOR CONSTRUCTION, RECONSTRUCTION, ALTERATION, REPAIR, IMPROVEMENT OR MAINTENANCE OF PUBLIC WORKS, WHERE THE COST IS MORE THAN \$50,000 AND, IN THE CASE OF STEEL ONLY, WHERE THE COST OF STEEL IS MORE THAN \$50,000 OR WHERE MORE THAN 10,000 POUNDS OF STEEL ARE REQUIRED, THE STATE WILL ACCEPT ONLY ALUMINU GLASS, OR STEEL PRODUCTS PRODUCED IN THE UNITED STATES. IN ADDITION, ITEMS OF MACHINERY OR EQUIPMENT PURCHASED FOR USE AT THE SITE OF PUBLIC WORKS SHALL BE MADE OF DOMESTIC ALUMINUM, GLASS OR STEEL, UNLESS THE COST OF THE PRODUCT IS LESS THAN \$50,000 OR LESS THAN 10,000 POUNDS OF STEEL ARE USED IN PUBLIC WORKS PROJECTS.</p> <p>FOREIGN MADE ALUMINUM, GLASS OR STEEL PRODUCTS MAY BE ACCEPTED ONLY IF THE COST OF DOMESTIC PRODUCTS IS FOUND TO BE UNREASONABLE. SUCH COST IS UNREASONABLE IF IT IS 20% OR MORE HIGHER THAN THE BID PRICE FOR FOREIGN MADE PRODUCTS. IF THE DOMESTIC ALUMINUM, GLASS OR STEEL PRODUCTS TO BE SUPPLIED OR PRODUCED IN A "SUBSTANTIAL LABOR SURPLUS AREA", AS DEFINED BY THE UNITED STATES DEPARTMENT OF LABOR, FOREIGN PRODUCTS MAY BE SUPPLIED ONLY IF DOMESTIC PRODUCTS ARE 30% OR MORE HIGHER IN PRICE THAN THE FOREIGN MADE PRODUCTS.</p> <p>IF, PRIOR TO THE AWARD OF A CONTRACT UNDER THE ABOVE PROVISIONS, THE SPENDING OFFICER OF THE SPENDING UNIT DETERMINES THAT THERE EXISTS A BID FOR LIKE FOREIGN ALUMINUM, GLASS OR STEEL THAT IS REASONABLE AND LOWER THAN THE LOWEST BID DOMESTIC PRODUCTS, THE SPENDING OFFICE MAY REQUEST, IN WRITING, A REEVALUATION AND</p>		

SEE REVERSE SIDE FOR TERMS AND CONDITIONS			
SIGNATURE	TELEPHONE	DATE	
<i>Karin D. Benefield</i>		6-18-09	
TITLE	V.EIN	ADDRESS CHANGES TO BE NOTED ABOVE	
V. Pres.			

WHEN RESPONDING TO RFQ, INSERT NAME AND ADDRESS IN SPACE ABOVE LABELED 'VENDOR'





State of West Virginia  
Department of Administration  
Purchasing Division  
2019 Washington Street East  
Post Office Box 50130  
Charleston, WV 25305-0130

### Request for Quotation

RFQ NUMBER
DEP14156

PAGE
8

ADDRESS CORRESPONDENCE TO ATTENTION OF
CHUCK BOWMAN 304-558-2157

VENDOR

\*311144600 304-732-8303  
PINEVILLE PAVING & EXCAVATING  
PO BOX 1290  
RT 10 SOUTH  
PINEVILLE WV 24874

SHIP TO

ENVIRONMENTAL PROTECTION  
DEPT. OF  
OFFICE OF SPECIAL RECLAMATION  
105 S. RAILROAD STREET  
PHILIPPI, WV  
26416-9998 304-457-3219

DATE PRINTED	TERMS OF SALE	SHIP VIA	F.O.B.	FREIGHT TERMS
05/07/2009				

BID OPENING DATE: 06/24/2009 BID OPENING TIME 01:30PM

LINE	QUANTITY	UOP	CAT NO	ITEM NUMBER	UNIT PRICE	AMOUNT
<p>REDUCTION IN THE LOWEST BID FOR SUCH DOMESTIC PRODUCTS. ALL VENDORS MUST INDICATE IN THEIR BID IF THEY ARE SUPPLYING FOREIGN ALUMINUM, GLASS OR STEEL.</p> <p>REV. 3/88</p> <p>EXHIBIT 9</p> <p>NOTICE FOR ISSUANCE &amp; ACKNOWLEDGEMENT OF CONSTRUCTION PROJECT ADDENDA</p> <p>THE ARCHITECT/ENGINEER AND/OR AGENCY SHALL BE REQUIRED TO ABIDE BY THE FOLLOWING SCHEDULE IN ISSUING CONSTRUCTION PROJECT ADDENDA FOR STATE AGENCIES:</p> <p>(1) THE ARCHITECT/ENGINEER SHALL PREPARE THE ADDENDUM AND A LIST OF ALL PARTIES THAT HAVE PROCURED DRAWINGS AND SPECIFICATIONS FOR THE PROJECT. THE ADDENDUM AND LIST SHALL BE FORWARDED TO THE BUYER IN THE STATE PURCHASING DIVISION. THE ARCHITECT/ENGINEER SHALL ALSO SEND A COPY OF THE ADDENDUM TO THE STATE AGENCY FOR WHICH THE CONTRACT IS ISSUED.</p> <p>(2) THE BUYER SHALL SEND THE ADDENDUM TO ALL INTERESTED PARTIES AND, IF NECESSARY, EXTEND THE BID OPENING DATE. ANY ADDENDUM SHOULD BE RECEIVED BY THE BUYER WITHIN FOURTEEN (14) DAYS PRIOR TO THE BID OPENING DATE.</p> <p>(3) ALL ADDENDA SHOULD BE FORMALLY ACKNOWLEDGED BY ALL BIDDERS AND SUBMITTED TO THE STATE PURCHASING DIVISION. THE SAME RULES AND REGULATIONS THAT APPLY TO THE ORIGINAL BIDDING DOCUMENT SHALL ALSO APPLY TO AN ADDENDUM DOCUMENT. THE ONLY EXCEPTION MAY BE FOR AN ADDENDUM THAT IS ISSUED FOR THE SOLE PURPOSE OF CHANGING A BID OPENING TIME AND/OR</p>						

SEE REVERSE SIDE FOR TERMS AND CONDITIONS

SIGNATURE <i>Kevin D. Bradford</i>	TELEPHONE 304-732-8303	DATE 6-18-09
TITLE V. Pres.	FEIN	ADDRESS CHANGES TO BE NOTED ABOVE

WHEN RESPONDING TO RFQ, INSERT NAME AND ADDRESS IN SPACE ABOVE LABELED 'VENDOR'



State of West Virginia  
 Department of Administration  
 Purchasing Division  
 2019 Washington Street East  
 Post Office Box 50130  
 Charleston, WV 25305-0130

# Request for Quotation

RFQ NUMBER  
 DEP14156

PAGE  
 9

ADDRESS CORRESPONDENCE TO ATTENTION OF  
 CHUCK BOWMAN  
 304-558-2157

VENDOR

\*311144600 304-732-8303  
 PINEVILLE PAVING & EXCAVATING  
 PO BOX 1290  
 RT 10 SOUTH  
 PINEVILLE WV 24874

SHIP TO

ENVIRONMENTAL PROTECTION  
 DEPT. OF  
 OFFICE OF SPECIAL RECLAMATION  
 105 S. RAILROAD STREET  
 PHILIPPI, WV  
 26416-9998 304-457-3219

DATE PRINTED	TERMS OF SALE	SHIP VIA	F.O.B.	FREIGHT TERMS
05/07/2009				

BID OPENING DATE: 06/24/2009 BID OPENING TIME 01:30PM

LINE	QUANTITY	UOP	CAT NO	ITEM NUMBER	UNIT PRICE	AMOUNT
				DEP14156		
<p>DATE .</p> <p>REV. 11/96</p> <p>EXHIBIT 10</p> <p>ADDENDUM ACKNOWLEDGEMENT</p> <p>I HEREBY ACKNOWLEDGE RECEIPT OF THE FOLLOWING CHECKED ADDENDUM(S) AND HAVE MADE THE NECESSARY REVISIONS TO MY PROPOSAL, PLANS AND/OR SPECIFICATION, ETC.</p> <p>ADDENDUM NOS. :</p> <p>NO. 1 ..... ✓</p> <p>NO. 2 ..... </p> <p>NO. 3 ..... </p> <p>NO. 4 ..... </p> <p>NO. 5 ..... </p> <p>I UNDERSTAND THAT FAILURE TO CONFIRM THE RECEIPT OF THE ADDENDUM(S) MAY BE CAUSE FOR REJECTION OF THE BIDS.</p> <p>VENDOR MUST CLEARLY UNDERSTAND THAT ANY VERBAL REPRESENTATION MADE OR ASSUMED TO BE MADE DURING ANY ORAL DISCUSSION HELD BETWEEN VENDOR'S REPRESENTATIVES AND ANY STATE PERSONNEL IS NOT BINDING. ONLY THE INFORMATION ISSUED IN WRITING AND ADDED TO THE SPECIFICATIONS BY AN OFFICIAL ADDENDUM IS BINDING.</p>						

SEE REVERSE SIDE FOR TERMS AND CONDITIONS

SIGNATURE <i>Karin O'Dougherty</i>	TELEPHONE	DATE 6-18-09
TITLE V. Pres.	ADDRESS CHANGES TO BE NOTED ABOVE	

WHEN RESPONDING TO RFQ, INSERT NAME AND ADDRESS IN SPACE ABOVE LABELED 'VENDOR'



State of West Virginia  
 Department of Administration  
 Purchasing Division  
 2019 Washington Street East  
 Post Office Box 50130  
 Charleston, WV 25305-0130

### Request for Quotation

RFQ NUMBER
DEP14156

PAGE
10

ADDRESS CORRESPONDENCE TO ATTENTION OF
CHUCK BOWMAN 304-558-2157

VENDOR

\*311144600      304-732-8303  
 PINEVILLE PAVING & EXCAVATING  
 PO BOX 1290  
 RT 10 SOUTH  
 PINEVILLE WV 24874

SHIP TO

ENVIRONMENTAL PROTECTION  
 DEPT. OF  
 OFFICE OF SPECIAL RECLAMATION  
 105 S. RAILROAD STREET  
 PHILIPPI, WV  
 26416-9998      304-457-3219

DATE PRINTED <b>05/07/2009</b>	TERMS OF SALE	SHIP VIA	F.O.B.	FREIGHT TERMS
-----------------------------------	---------------	----------	--------	---------------

BID OPENING DATE: **06/24/2009**      BID OPENING TIME **01:30PM**

LINE	QUANTITY	UOP	CAT NO	ITEM NUMBER	UNIT PRICE	AMOUNT
<p>..... <i>Karin A Boudrel</i> ..... SIGNATURE            ..... <i>Pineville Paving, Excavating, Inc.</i> ..... COMPANY            ..... <i>6-18-09</i> ..... DATE</p> <p>REV. 11/96</p> <p>NOTICE</p> <p>A SIGNED BID MUST BE SUBMITTED TO:</p> <p>DEPARTMENT OF ADMINISTRATION            PURCHASING DIVISION            BUILDING 15            2019 WASHINGTON STREET, EAST            CHARLESTON, WV 25305-0130</p> <p>THE BID SHOULD CONTAIN THIS INFORMATION ON THE FACE OF            THE ENVELOPE OR THE BID MAY NOT BE CONSIDERED:</p> <p>SEALED BID</p> <p>BUYER:                                      CB-23</p> <p>REQ. NO.:                                      DEP14156</p> <p>BID OPENING DATE:                      06/24/2009</p> <p>BID OPENING TIME:                      1:30 P.M.</p> <p>PLEASE PROVIDE A FAX NUMBER IN CASE IT IS NECESSARY            TO CONTACT YOU REGARDING YOUR BID:</p>						

SEE REVERSE SIDE FOR TERMS AND CONDITIONS			
SIGNATURE <i>Karin A Boudrel</i>	TELEPHONE	DATE <i>6-18-09</i>	
TITLE <i>V. Pres.</i>	FIRM	ADDRESS CHANGES TO BE NOTED ABOVE	

WHEN RESPONDING TO RFQ, INSERT NAME AND ADDRESS IN SPACE ABOVE LABELED 'VENDOR'



State of West Virginia  
 Department of Administration  
 Purchasing Division  
 2019 Washington Street East  
 Post Office Box 50130  
 Charleston, WV 25305-0130

# Request for Quotation

RFQ NUMBER  
**DEP14156**

PAGE  
**11**

ADDRESS CORRESPONDENCE TO ATTENTION OF  
**CHUCK BOWMAN**  
**304-558-2157**

VENDOR

\*311144600      304-732-8303  
**PINEVILLE PAVING & EXCAVATING**  
**PO BOX 1290**  
**RT 10 SOUTH**  
**PINEVILLE WV 24874**

SHIP TO

**ENVIRONMENTAL PROTECTION**  
**DEPT. OF**  
**OFFICE OF SPECIAL RECLAMATION**  
**105 S. RAILROAD STREET**  
**PHILIPPI, WV**  
**26416-9998      304-457-3219**

DATE PRINTED <b>05/07/2009</b>	TERMS OF SALE	SHIP VIA	F.O.B.	FREIGHT TERMS
-----------------------------------	---------------	----------	--------	---------------

BID OPENING DATE: **06/24/2009**      BID OPENING TIME **01:30PM**

LINE	QUANTITY	UOP	CAT NO	ITEM NUMBER	UNIT PRICE	AMOUNT
				<b>304-732-7855</b>		
PLEASE PRINT OR TYPE NAME OF PERSON TO CONTACT CONCERNING THIS QUOTE: <b>Kevin D Bradford</b>						
***** THIS IS THE END OF RFQ DEP14156 *****						<b>\$1,233,000.00</b>

SEE REVERSE SIDE FOR TERMS AND CONDITIONS

SIGNATURE: *Kevin D Bradford*      TELEPHONE:      DATE: **6-18-09**

TITLE: **V. Pres.**      ADDRESS CHANGES TO BE NOTED ABOVE

WHEN RESPONDING TO RFQ, INSERT NAME AND ADDRESS IN SPACE ABOVE LABELED 'VENDOR'

LOCATION MAP

MARYLAND

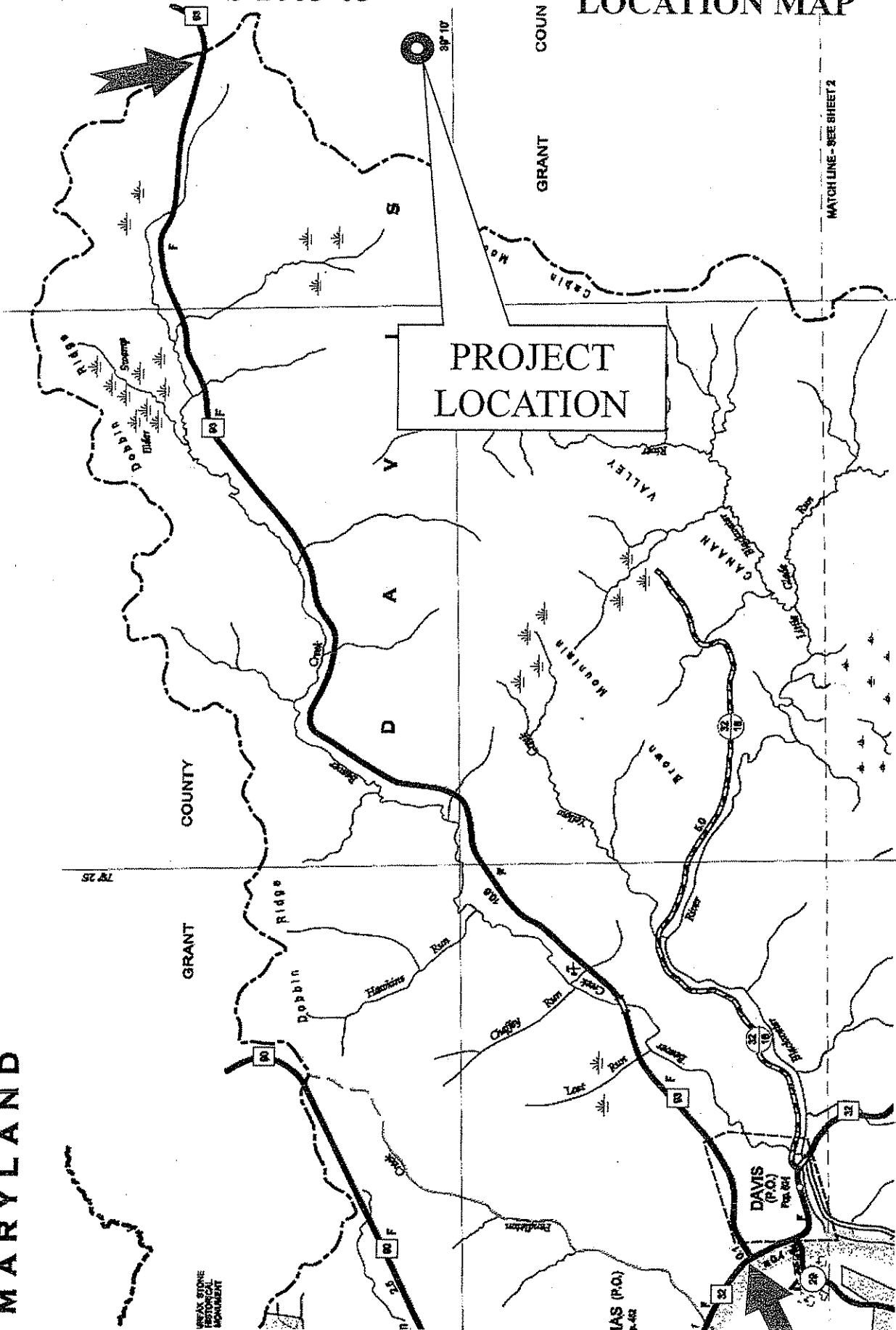

In Tucker County, from the intersection of State Route 32 and 93 near Davis, go 11.5 miles East on Rt 93 to the Tucker/Grant County line. You will also see a flashing caution light. Just past the caution light, turn right onto a gated haulroad. The sight is 5.5 miles out this road.

BUYER CB-23	PAGE <b>013</b>	REQ. OR PO NO. DEP 14156
SPENDING UNIT WEST VIRGINIA DEPARTMENT OF ENVIRONMENTAL PROTECTION/SPECIAL RECLAMATION		

WV-36a STATE OF WEST VIRGINIA  
 REV. 5-1-08 PURCHASING CONTINUATION SHEET  
 VENDOR:

**SCOPE OF WORK**

The successful bidder shall provide appropriate equipment, materials, labor, and any technical services needed for the successful reclamation of Buffalo Coal Company, Inc, Permit S-2003-03, and any disturbance associated with such operation. The General Performance Standards (GPS) shall apply to all items in Scope of Work.

Work necessary on this site will include the following items, but is not limited to these:

1. Upon mobilization to the site, which will be directed in a written Notice to Proceed, the access roads shall be developed in accordance with bid item #3. If, fuel and lubricants are to be stored on site, bid item # 2 shall be in place before fuel is delivered. Project sign is to be obtained and installed at beginning of work.
2. Storm water management in the form as described in bid item #11 shall be installed (described locations).
3. Concurrent and continuous reclamation shall begin at point A as shown on the site plan and shall end at point B. Backfill is required for pits 1&2. Pit 1 shall be backfilled first utilizing material adjacent to the pit. Any additional material needed shall be obtained from spoil area A. Pit 2 shall be backfilled following the backfilling of pit 1, and backfill material shall be obtained from spoil area A. Any disturbance to original ground shall be kept to a minimum. Regrading and topsoiling is required for all disturbed area. Revegetation is required for all disturbed areas. Reclamation is to be according to the attached specifications, plans, and clarifying discussions at the Pre-Bid Conference.
4. Construct riprap ditches or open limestone channels.
5. Remove structures and debris from site.
6. Upgrade access roads.
7. Install culverts.
8. Dewater pits and water treatment while discharging.
9. Alkalinity amendments to spoil material with lime.
10. Fertilize, lime, seed, and mulch approximately 60 acres of disturbed area.
11. Any other site specific items required.

I, David B. McCoy, the undersigned, hereby certify <sup>1</sup> that this Reclamation Plan is correct and shows to the best of my knowledge and belief all the information required by the surface mining laws of the State of West Virginia. The source of information was the approved mining and reclamation plan contained in the forfeited surface mine permit, existing site conditions and information contained in the WV DEP, Inspection and Enforcement files.

*David B. McCoy*

Registered Professional Engineer WV No. 14375

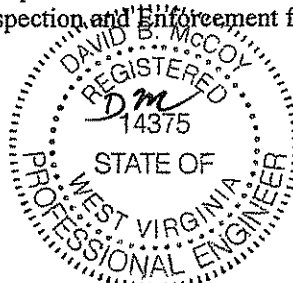

Date: 4-16-09

<sup>1</sup> The term "certify" as used herein is defined as follows: An engineer's certification of conditions is a declaration of professional judgment. It does not constitute a warranty or guarantee, either expressed or implied.

WV-36a STATE OF WEST VIRGINIA  
 REV. 5-1-08 PURCHASING CONTINUATION SHEET  
 VENDOR: Pineville Paving & Excavating Inc.

ITEM NO.	QUANTITY	DESCRIPTION	UNIT PRICE	AMOUNT
<b>BID SCHEDULE</b>				
PERMIT NAME: <u>BUFFALO COAL COMPANY INC.</u>				
PERMIT NUMBER(S): <u>S-2003-03</u>				
The DEP reserves the right to request additional information and supporting documentation regarding unit prices when the unit price appears to be unreasonable.				
1.0	LUMP SUM	<u>MOBILIZATION/DEMOBILIZATION/PROJECT SIGN</u> (5% Total Bid Maximum for this permit)	LUMP SUM	\$ <u>6,000.<sup>00</sup></u>
2.0	LUMP SUM	<u>SPILL CONTAINMENT AREA (S.C.A.)</u> (\$1,000.00 Maximum Bid for this permit)	LUMP SUM	\$ <u>1,000.<sup>00</sup></u>
3.0	<u>5500 LF</u>	<u>HAULROAD/ACCESS ROAD UPGRADE</u>	\$ <u>10.<sup>00</sup></u> PER LF	\$ <u>55,000.<sup>00</sup></u>
4.0	<u>500 TON</u>	<u>INCIDENTAL #1 STONE FOR ROAD UPGRADE</u>	\$ <u>22.50</u> PER TON	\$ <u>11,250.<sup>00</sup></u>
5.0	LUMP SUM	<u>PIT DEWATERING</u>	LUMP SUM	\$ <u>200,000.<sup>00</sup></u>
6.0	<u>800 TON</u>	<u>LIMING</u>	\$ <u>40.<sup>00</sup></u> PER TON	\$ <u>32,000.<sup>00</sup></u>
7.0	LUMP SUM	<u>BACKFILLING</u>	LUMP SUM	\$ <u>548,400.<sup>00</sup></u>
8.0	LUMP SUM	<u>REGRADING AND TOPSOILING</u>	LUMP SUM	\$ <u>120,000.<sup>00</sup></u>
9.0	<u>REVEGETATION</u>			
9.1	<u>60 AC</u>	<u>AGRICULTURAL LIME</u>	\$ <u>125.<sup>00</sup></u> PER ACRE	\$ <u>7,500.<sup>00</sup></u>
9.2	<u>60 AC</u>	<u>FERTILIZER</u>	\$ <u>125.<sup>00</sup></u> PER ACRE	\$ <u>7,500.<sup>00</sup></u>
9.3	<u>60 AC</u>	<u>MULCH</u>	\$ <u>125.<sup>00</sup></u> PER ACRE	\$ <u>7,500.<sup>00</sup></u>

WV-36a STATE OF WEST VIRGINIA  
 REV. 5-1-08 PURCHASING CONTINUATION SHEET  
 VENDOR:

9.4	<u>60</u> AC	<u>VEGETATIVE SPECIES</u>	\$ <u>125.<sup>00</sup></u> PER ACRE	\$ <u>7,500.<sup>00</sup></u>
10.0	<u>1</u> EA	<u>EXISTING SEDIMENT CONTROL STRUCTURE</u>	\$ <u>10,000.<sup>00</sup></u> PER EA	\$ <u>10,000.<sup>00</sup></u>
11.0	<u>2500</u> LF	<u>SEDIMENT CONTROL WITH SILT FENCE AND HAYBALE DIKE</u> (Max. Bid \$5.00 Per LF)	\$ <u>50</u> PER LF	\$ <u>1,250.<sup>00</sup></u>
12.0	<u>3500</u> LF	<u>RIPRAP DITCH</u>	\$ <u>25.<sup>00</sup></u> PER LF	\$ <u>87,500.<sup>00</sup></u>
13.0	<u>700</u> LF	<u>TRAPAZOIDAL RIPRAP DITCH</u>	\$ <u>60.<sup>00</sup></u> PER LF	\$ <u>42,000.<sup>00</sup></u>
14.0	<u>40</u> LF	<u>HDPE CULVERT 36 INCH DIAMETER</u>	\$ <u>45.<sup>00</sup></u> PER LF	\$ <u>1,800.<sup>00</sup></u>
15.0	<u>40</u> LF	<u>HDPE CULVERT 24 INCH DIAMETER</u>	\$ <u>45.<sup>00</sup></u> PER LF	\$ <u>1,800.<sup>00</sup></u>
16.0	LUMP SUM	<u>STRUCTURE AND/OR DEBRIS REMOVAL</u>	LUMP SUM	\$ <u>30,000.<sup>00</sup></u>
<b>TOTAL PERMIT S-2003-03</b>				\$ <u>1,233,000.<sup>00</sup></u>



BUYER CB-23	PAGE <b>016</b>	REQ. OR PO NO. DEP 14156
SPENDING UNIT WEST VIRGINIA DEPARTMENT OF ENVIRONMENTAL PROTECTION/SPECIAL RECLAMATION		

WV-36a STATE OF WEST VIRGINIA  
REV. 5-1-08 PURCHASING CONTINUATION SHEET  
VENDOR:

## BID ITEM TECHNICAL SPECIFICATIONS

### 1.0 MOBILIZATION/DEMObILIZATION/PROJECT SIGN PROJECT SIGN

A project sign shall be obtained or manufactured and installed as indicated on the attached specifications and details. Payment for this sign shall be incidental to the mobilization item. No separate payment will be made.

#### MOBILIZATION

This work shall consist of the performance of construction preparatory operations, including the movement of personnel, equipment and other facilities to the project site necessary to begin work on a substantial phase of the contract.

#### DEMObILIZATION

Prior to demobilization, an inspection shall be conducted by the Department of Environmental Protection and the contractor to insure compliance with contract performance. Once compliance is ascertained, demobilization activities can be initiated and completed. Demobilization shall be totally completed before the invoice for payment shall be processed.

#### PAYMENT

The lump sum bid for this item shall not exceed 5% of the total bid for this permit. Payment shall be made in two 50% amounts, one upon completion of the mobilization and project sign items and the second payment at the completion of demobilization. No deduction shall be made nor shall any increase be made in the lump sum item amount, regardless of decreases or increases in the final total contract amount or any other reason.

### 2.0 SPILL CONTAINMENT AREA (S.C.A.)

Spill containment measures shall be used for fuel and lubricant storage areas. All containers, barrels, buckets, cans, etc., are to be legally disposed of off site. Used lubricants are to be disposed of according to state law to minimize pollution to the local surface and ground water supplies. Spills are the responsibility of the contractor and need immediate clean up and maintained at no expense to the State. This S.C.A. shall be constructed in accordance with the typical drawing specification. (See Attachment) Alternate containment measures will be considered for approval by the Program Manager if acceptable results can be shown. Fuel tanks manufactured with secondary containment are desirable. Minimum secondary containment is 110 percent. (Bid limited to \$1,000.00 maximum)

### 3.0 HAULROAD/ACCESS ROAD UPGRADE

The contractor shall maintain and/or construct haulroad/access road(s) during the reclamation process to provide access on a well drained surface. Plan to upgrade the existing access road to the specifications and details as indicated in the Upgrade Access Road drawing. The access road on the reclamation site shall be graded, sloped, and maintained to drain to provide a road surface free of excessive mud and standing waters at all times while work is in progress. Upon completion of all reclamation activities, a final 3 inch layer of 1 ½ crusher run limestone shall be placed on the roadway. Roads which are below the project shall be guarded against rolling rock and removal of rocks done as necessary. Dust-control measures may be necessary if hauling creates airborne material. Snow removal is to be included in this item.

### 4.0 INCIDENTAL #1 STONE FOR ROAD UPGRADE

During construction of culvert installations, roadway ditch improvements, and reshaping of the roadway, areas may need additional base layer stone. After any necessary re-compaction and re-grading work on roadways has been performed by the contractor, a six (6) inch layer of #1 limestone (3.5" to 1.5" size) shall be placed as needed. This stone shall be graded and tracked in with a dozer or other equipment to achieve a compacted base for the final top layer of 1 ½ inch crusher run limestone (separate bid item).

Payment shall be paid per ton of stone applied by weight ticket and will be made at completion of all work

BUYER CB-23	PAGE <b>017</b>	REQ. OR PO NO. DEP 14156
SPENDING UNIT WEST VIRGINIA DEPARTMENT OF ENVIRONMENTAL PROTECTION/SPECIAL RECLAMATION		

WV-36a STATE OF WEST VIRGINIA  
REV. 5-1-08 PURCHASING CONTINUATION SHEET  
VENDOR:

and acceptance by DEP.

### 5.0 PIT DEWATERING

Two pits will need to be dewatered prior to backfilling operations. Pit 1 has an average depth of 25 feet with the deepest areas of 30 feet adjacent to the highwall and in the center. Pit 2 has an average depth of 20 feet. The contractor shall treat all water discharge to a pH of 6-9 throughout the dewatering process.

Pits shall be dewatered in the following manner in order to facilitate sediment control. Pit 1 shall be dewatered first with the water being pumped into pit 2. Upon completion of backfilling of pit 1, pit 2 shall be dewatered. The water from pit 2 shall be pumped into an old pit area shown on the site map as "temporary drainage control" and from there into a ditch to a cell that is part of the existing sediment pond. Pits shall remain dewatered during backfilling. Water treatment by the contractor shall take place in the existing sediment structure, when pit water is being pumped and discharged. This is a lump sum item.

### 6.0 LIMING

Liming of open pits is to be carried out at a rate of 40 tons/acre. All potentially toxic material shall be cleaned from the pavement prior to spreading lime uniformly over the exposed pavement. This potentially toxic material shall be placed on a pad prepared in the backfilling of the pits. The top of the pad shall be a minimum of ten (10) feet above the elevation of saturation and twenty (20) feet from the highwall. Lime shall be blended with the toxic material or (lime shall be spread over top of toxic material.) Coal refuse shall be treated in the same manner as the toxic material above. The specifications for this lime shall be the same as required in the Agricultural Lime bid item.

### 7.0 BACKFILLING

Areas of this project subject to backfilling to achieve the post-mining land-use shall: be accomplished in a continuous concurrent manner on all surface disturbances within the original permit and associated disturbed areas as existing at bid showing; be filled by mechanical methods to eliminate highwall and rock outcropping, to produce slopes of consistent lines and of the approximate original contour; be free of protruding rock and debris; be compacted in a progressive backfilling manner with mechanical equipment to ensure stability of backfill material. Potentially toxic material shall be placed on an alkaline material /clean pad a minimum of ten (10) feet above the elevation of saturation and twenty (20) feet from the highwall. Upon final placement, the material shall be compacted to minimize air contact and promptly covered by a minimum of ten (10) feet of non toxic overburden. The maximum acceptable slope of any backfill face shall not exceed two (2) horizontal to one (1) vertical, unless otherwise stated. Backfilling shall cease during periods of adverse site conditions. (For example: excessive soil moisture) The estimated area of backfilling is 19 acres. It shall be the contractor's responsibility to verify acreage for bidding purposes. This is a lump sum bid item.

### 8.0 REGRADEING AND TOPSOILING

Concurrent regrading and topsoiling shall immediately follow backfilling and shall distribute topsoil or the best available material to support vegetation, as identified by the Department of Environmental Protection contact person. This item shall include the construction of sediment control sumps, the removal of sediment control sumps, the grading of spoil and/or fill materials. Topsoil presently stockpiled on site shall be preserved and spread on the fill surface. In the absence of stockpiled topsoil, material which can be used as a topsoil substitute shall be identified, segregated, and stockpiled for spreading on the surface. Following final regrading of the mine site, the original topsoil and upper horizon material shall be spread over the backfill to an approximate depth of 18 inches to provide growth medium for permanent grasses and seedlings. Seed bed preparation shall be performed using light equipment and minimal passes to avoid compaction. For forestry purposes, the growth medium shall be left loose and non-compacted with random depressions left on the surface of the final backfill. Where possible, some organic matter may be added to the growth medium in the form of tree tops, root wads, leaves, etc. Regrading and topsoiling shall be conducted prior to and in preparation for the revegetation item. The estimated area of regrading and topsoiling is

BUYER CB-23	PAGE <b>018</b>	REQ. OR PO NO. DEP 14156
SPENDING UNIT WEST VIRGINIA DEPARTMENT OF ENVIRONMENTAL PROTECTION/SPECIAL RECLAMATION		

WV-36a STATE OF WEST VIRGINIA  
REV. 5-1-08 PURCHASING CONTINUATION SHEET  
VENDOR:

60 acres. It shall be the contractor's responsibility to verify acreage for bidding purposes. This is a lump sum bid item.

### 9.0 REVEGETATION

The actual seeding date, within the work performance period, shall be at the discretion of the contractor, but a permanent vegetative cover must be established. Verification of materials used shall be required for payment. Seeding shall commence after seedbed preparation on a loose and uncompacted soil and with the approval of the Department of Environmental Protection. Contractor shall provide equipment as necessary to secure approval of the seedbed. Revegetation activities shall be carried out in a continuous, concurrent, timely and uniform manner. Failure to do this may result in nonpayment for portions of or the entire Revegetation item. Hydroseeding or broadcast seeding with the approved species is acceptable. The application rate may be increased but the ratio is to remain constant, but no additional monetary compensation will be awarded. Areas outside the limits of construction, disturbed by the contractor, shall be revegetated by the contractor at no expense to DEP. Water utilized for hydroseeding shall be free of injurious or other toxic substances harmful to plant life. The source of water is subject to the approval of the DEP Specialist. It shall be the vendor's responsibility to repeat the procedures under REVEGETATION until a permanent vegetation is established. The acreage quantities in this contract are for bidding purposes only. It shall be the contractor's responsibility to verify acreage for bidding purposes. The contractor shall not exceed the contract amount of 60 acres. If any additional amount is required, the contractor must have written approval from the DEP, prior to any additional work being completed.

A warranty period of one (1) year shall commence upon completion and payment of the revegetation item of the contract. No payment will be made for additional seeding necessary to comply with warranty requirements. The warranty period will be extended for one (1) year from the date of the last augmented seeding done by the contractor. The performance bond and labor and materials bond shall remain in effect throughout the warranty period. The Standards for Evaluating Vegetative Cover as presented in Title 38, CSR2, Section 9 of the West Virginia Surface Mining Reclamation Regulations will apply.

Equipment for the retracking/scarification to eliminate rills and gullies shall be mobilized and utilized to produce slopes consistent with the regrading and topsoiling bid item prior to warranty reseeding. No additional payment will be made by DEP for this warranty work.

### 9.1 AGRICULTURAL LIME

Unless otherwise specified, all lime used shall be registered with the West Virginia Department of Agriculture, have an 85% minimum calcium carbonate equivalent, and meet the fineness classification no larger than that for ground lime. The following fineness classifications or combinations of lime are acceptable:

- Pulverized - 100% passing a U.S. Standard 20 mesh sieve
  - 70% passing a U.S. Standard 100 mesh sieve
- Ground - 90% passing a U.S. Standard 20 mesh sieve
  - 50% passing a U.S. Standard 60 mesh sieve
  - 35% passing a U.S. Standard 100 mesh sieve

Use of blends and low-grade agricultural liming materials shall require prior approval. Lime shall be spread as soon as possible after delivery to site. Lime shall be applied evenly and uniformly distributed over the treated area. Lime shall be thoroughly mixed into the soil material. Lime subjected to adverse conditions before spreading will be deemed unacceptable. Failure to complete this phase shall result in nonpayment of this bid item.

Lime shall be applied at 5 ton/acre.

WV-36a STATE OF WEST VIRGINIA  
 REV. 5-1-08 PURCHASING CONTINUATION SHEET  
 VENDOR:

---

**9.2 FERTILIZER**

Fertilizer rates given for REVEGETATION are for 300 lbs. of 10-20-20 per acre. These rates are minimum and for bidding purposes.

Fertilizer shall be applied evenly and uniformly distributed over the treated area. Common complete fertilizers which meet the minimum standards are acceptable.

**9.3 MULCH**

Acceptable mulch for this project is wood fiber, hay, or straw.

Mulch: Wood Fiber @ 1.0 ton/Acre

Hay or straw mulch may be substituted at a rate of 2 tons/Acre

**9.4 VEGETATIVE SPECIES**

Seeding rate required is for pure live seed (pls) in pounds per acre. The use of annuals or cover crops will not be considered for vegetative success.

<u>VEGETATIVE SPECIES</u> <sup>1</sup>	<u>RATE/ACRE</u> <sup>1</sup>
Perennial rye grass	@ 10 lbs/acre
Birdsfoot Trefoil <sup>2</sup>	@ 10 lbs/acre
White clover	@ 3 lbs/acre
Weeping lovegrass	@ 3 lbs/acre
Redtop	@ 5 lbs./acre
Foxtail Millet <sup>3</sup>	@ 5 lbs/acre
Wheat or Oats <sup>4</sup>	@ 10 lbs/acre

1. Seeding rate suggested is for pure live seed (pls) in pounds per acre.
2. Herbaceous legumes must be treated with the appropriate bacterium before seeding.
3. Spring mix.
4. Fall mix.

BUYER CB-23	PAGE <b>020</b>	REQ. OR PO NO. DEP 14156
SPENDING UNIT WEST VIRGINIA DEPARTMENT OF ENVIRONMENTAL PROTECTION/SPECIAL RECLAMATION		

WV-36a STATE OF WEST VIRGINIA  
REV. 5-1-08 PURCHASING CONTINUATION SHEET  
VENDOR:

---

### **10.0 EXISTING SEDIMENT CONTROL STRUCTURE**

An existing sediment pond shall be cleaned out and resized. At this time the pond is approximately 150 feet by 126 feet. The reduced size shall be 150 feet by 75 feet. Depth of the pond shall be eight (8) feet with two (2) feet of freeboard. Such structures shall be cleaned out when the sediment capacity reaches 60%, repaired, and maintained until demobilization. This item will be a one-time payment. Clean-out and maintenance shall be conducted by the contractor at no expense to DEP.

### **11.0 SEDIMENT CONTROL WITH SILT FENCE AND HAYBALE DIKE**

Disturbed areas which have storm water runoff and does not pass through a sediment control structure shall utilize the following Best Management Practice (BMP) methods to manage storm water runoff. For more information on BMP methods go to the WVDEP website <http://www.wvdep.org/dwwm/stormwater/BMP.htm> and click on **BMP Manual**. The WV Erosion and Sediment Control Best Management Practice Manual may be accessed or printed. This item has a Maximum Bid of \$5.00/LF of silt fence and hay bale material used on site.

1. Silt fence shall be utilized on perimeter barriers and shall be properly removed after permanent vegetation has been established. See attached drawing for further details.
2. For slope stability, place bales on the contour; at the top of cuts; and at the toe of slopes. Bales shall be placed in a row with ends tightly abutting the adjacent bales.
3. Bales shall be securely anchored in place by stakes or rebars driven through the bales. Rebar to be removed at the direction of DEP. The first stake in each bale shall be driven toward previously laid bale to force the bales together.
4. Construction of sediment control sumps before culvert inlets and/or rock check dams in ditch lines may become necessary to supplement the silt fence and hay bale dikes. These items shall be installed upon request of the DEP onsite representative. Sumps and rock check dams shall be incidental to this bid item.

### **12.0 RIPRAP DITCH**

Provide all materials, excavate and construct ditch or channel as indicated on the attached typical plans, cross-section, specifications, and as discussed at the Pre-Bid Showing. Channels and ditches shall be free draining upon completion of construction. Length of ditch may be adjusted to meet on site conditions. (See riprap specifications) R-5 limestone riprap shall be used at a thickness of 1 ½ feet. The top width of the ditch shall be four (4) feet. Payment shall be for the linear feet of ditch installed.

### **13.0 TRAPEZOIDAL DITCH**

Provide all materials, excavate and construct six-foot trapezoidal ditches as indicated on the attached typical plans, cross-section, specifications, and as discussed at the Pre-Bid Showing. Channels shall be free draining upon completion of construction. Length of channel may be adjusted to meet on site conditions. (See riprap specifications) R-5 limestone riprap shall be used at a thickness of 1 ½ feet. The top width of the ditch shall be ten (10) feet. Payment shall be for the linear feet of ditch installed.

### **14.0 HDPE CULVERT 36 INCH DIAMETER**

The culvert shall be HDPE, dual wall smooth interior corrugated twenty (20) foot joint type. The pipe joints shall be silt-tight and the pipe shall meet ASTM D3350 manufacturing standards. The culvert locations shall be determined by the onsite DEP representative.

BUYER CB-23	PAGE 021	REQ. OR PO NO. DEP 14156
SPENDING UNIT WEST VIRGINIA DEPARTMENT OF ENVIRONMENTAL PROTECTION/SPECIAL RECLAMATION		

WV-36a STATE OF WEST VIRGINIA  
REV. 5-1-08 PURCHASING CONTINUATION SHEET  
VENDOR:

**STANDARD INSTALLATION**

Culverts installed in access roads shall cross the road at a 30 degree angle downgrade with a minimum grade of three percent (3%) from inlet to outlet, except in streams or diversion ditches where the pipe shall be installed straight and coincide with the normal direction of flow.

The culvert inlet and outlet ends shall be protected by a headwall of stable non-erodible material and the slope at the outlet shall be protected with an apron of rock riprap, energy dissipater or other designated material. The culvert shall be installed in a trench excavated in solid undisturbed ground or formed by compacted earth.

The culvert shall be imbedded in a formed trench to a depth no less than 1/10 the outside diameter of the pipe. Selected backfill material shall be placed around the culvert in four (4) inch layers and thoroughly compacted by means of hand tamping or manually directed power tampers or plate vibrators.

The culvert shall be covered with a minimum of eighteen (18) inches of material. Payment shall be for length of culvert installed.

**19.0 HDPE CULVERT 24 INCH DIAMETER**

The culvert shall be HDPE, dual wall smooth interior corrugated twenty (20) foot joint type. The pipe joints shall be silt-tight and the pipe shall meet ASTM D3350 manufacturing standards. The culvert locations shall be determined by the onsite DEP representative.

**STANDARD INSTALLATION**

Culverts installed in access roads shall cross the road at a 30 degree angle downgrade with a minimum grade of three percent (3%) from inlet to outlet, except in streams or diversion ditches where the pipe shall be installed straight and coincide with the normal direction of flow.

The culvert inlet and outlet ends shall be protected by a headwall of stable non-erodible material and the slope at the outlet shall be protected with an apron of rock riprap, energy dissipater or other designated material. The culvert shall be installed in a trench excavated in solid undisturbed ground or formed by compacted earth.

The culvert shall be imbedded in a formed trench to a depth no less than 1/10 the outside diameter of the pipe. Selected backfill material shall be placed around the culvert in four (4) inch layers and thoroughly compacted by means of hand tamping or manually directed power tampers or plate vibrators.

The culvert shall be covered with a minimum of twelve (12) inches of material. Payment shall be for length of culvert installed.

**20.0 STRUCTURE AND/OR DEBRIS REMOVAL**

All existing man-made items particular to the site and not to be utilized in the total reclamation of this site shall be demolished (if necessary) and disposed of in a legal manner. All iron, steel, aluminum, or any other metal, plastic, or any other man made material, including but not limited to I-Beams, Angle Iron, Channel Iron, Corrugated Metal, Flat Metal, Floc Drums, Grease Drums, Pipe or Conduit is to be dismantled, removed and properly disposed of off site and according to state, local, and federal requirements. These structures are identified as:

All transformers, rectifiers, and other electrical structures, which may or may not contain toxic materials, shall be removed.

BUYER CB-23	PAGE 022	REQ. OR PO NO. DEP 14156
SPENDING UNIT WEST VIRGINIA DEPARTMENT OF ENVIRONMENTAL PROTECTION/SPECIAL RECLAMATION		

WV-36a STATE OF WEST VIRGINIA  
REV. 5-1-08 PURCHASING CONTINUATION SHEET  
VENDOR:

---

## BID PREPARATION INFORMATION

### HISTORICAL INFORMATION

Prospective bidders may review files at the West Virginia Department of Environmental Protection, Charleston, WV office, or the Regional West Virginia Department of Environmental Protection Office at 105 South Railroad St., Philippi, WV 26416. These files may contain additional information not included in the contract. Documents including, but not limited to, permit applications, permits, inspection reports, environmental documents, permit violation history, geological and geotechnical information, probable hydrologic consequences, maps, modifications, NPDES information and other related data. Copies may be obtained upon request and payment of copying fees.

### EXAMINATION OF BID PACKAGE AND SITE OF WORK

The bidder is required to examine, carefully, the bid package (plans, specifications, supplemental specifications, contract forms, etc.) and the site of the work contemplated. The submission of a bid shall be considered prima facie evidence that the bidder has made such examination and has judged for and satisfied themselves as to the character, quantity, and quality of work to be performed and the materials required to be furnished under the contract.

### PREBID CONFERENCE

Only the prospective bidders on the sign-in sheet in attendance for the entire Pre-Bid Conference will be eligible to submit bids for consideration of this project. Considerable foot travel over rough terrain and/or inclement weather may be required.

### VIDEO

The information given at the pre-bid showing by the project contact person or the assigned person shall be documented on video tape and shall be an integral part of this contract's requirements, but will not supersede the written contract. All information on video tape that is new or provides clarification to the specifications, will be issued in writing by a formal addendum and will become part of the written contract.

### INTENT OF CONTRACT

The intent of the contract is for the reclamation/restoration of forfeited mine lands as required by West Virginia Department of Environmental Protection. The contractor is to provide for the construction and completion in every detail of the work described. The Contractor shall furnish all labor, materials, equipment, tools, transportation, and supplies required to complete the work in accordance with the Plans, Specifications, and terms of the Contract.

Should any misunderstanding arise as to the intent or meaning of the Contract, or any discrepancy appear, the decision of the Director of Division of Land Restoration shall be final.

BUYER CB-23	PAGE 023	REQ. OR PO NO. DEP 14156
SPENDING UNIT WEST VIRGINIA DEPARTMENT OF ENVIRONMENTAL PROTECTION/SPECIAL RECLAMATION		

WV-36a STATE OF WEST VIRGINIA  
REV. 5-1-08 PURCHASING CONTINUATION SHEET  
VENDOR:

## GENERAL PERFORMANCE STANDARDS

### INTRODUCTION

The performance standards and non-compliance penalties which govern special reclamation-bond forfeiture projects are in Chapter 22A, Article 3, of the Code of West Virginia and subsequent rules and regulations. The following performance standards are of a general nature and do not represent all the performance standards applicable to a special reclamation-bond forfeiture project. However, some or all of these standards will pertain to each project.

### BACKFILLING

1. Unless otherwise noted, the highwall shall be eliminated and the disturbed area graded to the approximate original contour.
2. The material used to backfill and eliminate the highwall shall be sufficiently compacted so as to insure stability of the backfill throughout the warranty period.
3. The land above the highwall shall not be disturbed unless otherwise directed.
4. The best available material to support vegetation, sufficient to establish a permanent vegetative cover and to achieve the approved post mining land use, shall be used.

### LIFE OF CONTRACT

The purchase order contract becomes effective on the starting date as specified in the notice to proceed as issued by the Department of Environmental Protection. This contract extends for a period of one (1) year and may be renewed until such "reasonable time" thereafter as is necessary to complete the payment therefore. A responsible Contractor's Agent shall be on the site at all working times who demonstrates a knowledge of mined land reclamation, contract requirements and responds to DEP (owner) inspections.

### WORK PERFORMANCE PERIOD

The work performance period is a defined portion of the contract in which all items shall be completed. The work performance period is to be performed within 365 calendar days. Extensions may be granted based upon contractor's performance, weather conditions and site-specific site conditions.

### NOTICE TO PROCEED

A notice to proceed shall be issued to the Contractor by the project contact person for the Department of Environmental Protection. Actual construction may only begin after a Notice to Proceed is given and as specified. Such notice shall specify the starting date of the Purchase Order, the work performance period, and the completion date of the work performance period.

### PRE-CONSTRUCTION CONFERENCE

The Contractor in possession of the awarded purchase order shall schedule a Pre-Construction Conference on the site within ten (10) days after receiving the Notice To Proceed. The Contractor's foreman or the on-the-ground supervisor must be in attendance.



BUYER CB-23	PAGE 024	REQ. OR PO NO. DEP 14156
SPENDING UNIT WEST VIRGINIA DEPARTMENT OF ENVIRONMENTAL PROTECTION/SPECIAL RECLAMATION		

WV-36a STATE OF WEST VIRGINIA  
REV. 5-1-08 PURCHASING CONTINUATION SHEET  
VENDOR:

**GENERAL SUPERVISION** - This contract is under the general supervision of the West Virginia Department of Environmental Protection's contact person for the purpose of contract compliance inspection only. Contractor shall supervise work being conducted at all times. All services rendered by the Engineer/Contact Person consist of professional opinions and recommendations made in accordance with generally accepted engineering practice. Under no circumstances is it the intent of the Engineer/Contact Person to directly control the physical activities of the Contractor or the Contractor's workmen's accomplishment of work on this project.

**CONTRACTOR RESPONSIBILITY**

The contractor is responsible for compliance with all aspects of this written contract. No changes will be honored without prior approval from the Program Supervisor.

**LAWS TO BE OBSERVED**

The Contractor shall keep fully informed of all Federal and State laws, all local laws, ordinances, and regulations and all orders and decrees of bodies or tribunals having any jurisdiction or authority, which in any manner affect those engaged or employed on the work, or which in any way affect the conduct of the work. The Contractor shall at all times observe and comply with all such laws, ordinances, regulations, orders and decrees; and shall protect and indemnify the State and its representatives against any claim or liability arising from or based on the violation of any such laws, ordinances, regulations, orders, or decrees, whether by themselves, their subcontractors or their employees.

**PERMITS, LICENSES AND TAXES**

The Contractor shall procure all permits and licenses, pay all charges, fees, and taxes, and give all notices necessary and incidental to the due and lawful prosecution of the work.

**CONCURRENT RECLAMATION**

Reclamation of this project shall commence at a definite point as defined and shall progress from that point with total reclamation to include backfilling, grading/regrading, and revegetation. Changes may be granted based upon weather or differing site conditions with prior approval.

**WATER QUALITY CONTROL**

Shall commence with initial start-up of the project and remain in effect for the extent of the backfilling, regrading and revegetation activity. DEP obtains a storm water permit for each project from the Water Resources Division. (General Water Pollution Control Permit WVO115924) The Contractor is responsible for performing the best management practices. Adequate facilities shall be installed, operated and maintained using the best management practices of the U.S. Environmental Protection Agency's Non-Point Source (NPS) Program for sediment control during the active reclamation. The contractor shall take any and all steps necessary to prevent erosion or silting problems from occurring and to minimize pollution or sedimentation of the stream. If any such problems develop, the contractor shall be responsible to take immediate corrective action. No separate payment for this work will be honored. All impounded waters which require removal during reclamation, shall be pumped with appropriate measures taken to prevent erosion from the discharge. The contractor shall be responsible for treatment of said waters to meet pH standards. The water shall be discharged only when the quality meets a pH equivalent to the pH of the receiving stream but not less than 6.0.

BUYER CB-23	PAGE <b>025</b>	REQ. OR PO NO. DEP 14156
SPENDING UNIT WEST VIRGINIA DEPARTMENT OF ENVIRONMENTAL PROTECTION/SPECIAL RECLAMATION		

WV-36a            STATE OF WEST VIRGINIA  
REV. 5-1-08      PURCHASING CONTINUATION SHEET  
VENDOR:

**DIFFERING SITE CONDITIONS**

During the progress of the work, if subsurface or latent physical conditions are encountered at the site differing materially from those indicated in the contract or if unknown physical conditions of an unusual nature, differing materially from those ordinarily encountered and generally recognized as inherent in the work provided by the contract, are encountered at the site, the party discovering such conditions shall promptly notify the other party in writing of the specific differing conditions before they are disturbed and before the affected work is performed.

Upon written notification, the Engineer/Contact Person will investigate the conditions, and if determined that the conditions materially differ and cause an increase or decrease in the cost or time required for the performance of any work under the contract, an adjustment, excluding loss of anticipated profits, will be made and the contract modified in writing accordingly. The Engineer/Contact Person will notify the Contractor of DEP's determination whether or not an adjustment of the contract is warranted.

No contract adjustment which results in a benefit to the Contractor will be allowed unless the Contractor has provided the required written notice.

No contract adjustment will be allowed under this clause for any effects caused on unchanged work.

**HANDLING AND STORAGE OF MATERIALS**

Materials which are stored on site, before utilization, shall be stored so as to assure the preservation of their quality and fitness for the work. Stored materials, even though approved before storage, may be inspected again prior to their use in the work. Damaged or deteriorated materials shall be removed and replaced by materials meeting the original specifications.

Aggregate stockpiles shall be made on ground that is denuded of vegetation, hard, and well drained. Removal of aggregate from the stockpile shall be done in a manner which will not result in the inclusion of foreign material into the aggregate. The use of the aggregate will determine if exceptions are permitted.

All materials shall be handled in such a manner as to preserve their quality and fitness for the work.

**MAINTENANCE DURING CONSTRUCTION**

The contractor shall maintain the work during construction and until the project is accepted. All cost of maintenance work during construction and before the project is accepted shall be included in the unit or lump sum prices on the various pay items.

**FINAL INSPECTION**

A final inspection meeting by the Department of Environmental Protection's Specialist and the contractor is required for the construction phase and prior to demobilization.

**ACREAGE QUANTITIES**

The acreage quantities in this contract are for bidding purpose and are set (definite) number for the project area as specified at the pre-bid showing. Only surveyed acreage's through figures the Contractor and/or the State develops will be honored to alter these acreage numbers.

BUYER CB-23	PAGE 026	REQ. OR PO NO. DEP 14156
SPENDING UNIT WEST VIRGINIA DEPARTMENT OF ENVIRONMENTAL PROTECTION/SPECIAL RECLAMATION		

WV-36a STATE OF WEST VIRGINIA  
REV. 5-1-08 PURCHASING CONTINUATION SHEET  
VENDOR:

**PAYMENT**

Invoices must be submitted on prescribed Department of Environmental Protection, Special Reclamation Program forms and include verification. Certified contractor payrolls for operators directly involved in this project and a current workers compensation certificate must accompany each invoice for payment. Verification of wage rates may include employee interviews. Invoices shall be signed in blue ink so that it is easy to verify that document is an original.

MOBILIZATION/DEMOLIBILIZATION shall be invoiced at fifty percent (50%) with the first invoice and the last 50% invoiced after demobilization and acceptance of the road abandonment or final invoice. Demobilization must have written approval.

SPILL CONTAINMENT AREA shall not exceed \$1,000.00 and will be payable in two payments. The first fifty percent (50%) payable with the first invoice and the remainder payable when all fuel tanks, containers and etc., are removed from the site.

Lump sum items shall be percentage payments based on work completed at time of invoice and paid upon acceptance by the Department of Environmental Protection.

Unit items shall be invoiced by specified units completed and accepted by the DEP.

**FAILURE TO COMPLETE ON TIME AND LIQUIDATED DAMAGES**

Time is an essential element of the Contract and it is important that the work be completed within the time specified. The cost to the Department of the administration of the Contract, including engineering, inspection and supervision, will increase as the time required to complete the work is increased.

The work performance period as specified in the contract's Notice to Proceed shall be complied with or result in liquidated damages. Such damages shall be assessed at an amount of two hundred and fifty dollars (\$250.00) per day for each and every day beyond the work performance period as specified in the Notice to Proceed. The total amount of daily charges will be deducted from any moneys due the Contractor, not as a penalty but as liquidated damages.

**REVEGETATION AND WARRANTY**

The seeding date shall be at the discretion of the contractor once an approved seedbed has been prepared. In all cases a permanent vegetative cover capable of supporting the post-mining land use must be established. A warranty period of one (1) year shall commence upon completion and payment of the revegetation item of the contract. No payment will be made for additional seeding necessary to comply with warranty requirements. The warranty period will be extended for one (1) year from the date of the last augmented seeding done by the contractor. The performance bond and labor and materials bond shall remain in effect throughout the warranty period. The Standards for Evaluating Vegetative Cover as presented in Title 38, CSR2, Section 9 of the West Virginia Surface Mining Reclamation Regulations will apply.

Equipment for the retracking/scarification to eliminate rills and gullies shall be mobilized and utilized to produce slopes consistent with the regrading and topsoiling bid item prior to warranty reseeding. No additional payment will be made by DEP for this warranty work.

Water utilized for hydroseeding shall be free of injurious or other toxic substances harmful to plant life. The source of water is subject to the approval of the DEP contact person.

BUYER CB-23	PAGE 027	REQ. OR PO NO. DEP 14156
SPENDING UNIT WEST VIRGINIA DEPARTMENT OF ENVIRONMENTAL PROTECTION/SPECIAL RECLAMATION		

WV-36a STATE OF WEST VIRGINIA  
REV. 5-1-08 PURCHASING CONTINUATION SHEET  
VENDOR:

**CONTRACT NON-COMPLIANCE**

If in the opinion of the Department of Environmental Protection the contract is not in compliance with any line item specification, that portion of the project shall cease until a compliance schedule and understanding is demonstrated in writing and accepted by the Director of Division of Land Restoration.

**CONTRACT DELETIONS**

Any line item, or any portion thereof, may be deleted when determined by the project contact person that such line item, or portion thereof, is deemed unnecessary for the successful reclamation of this project. No claim for loss of anticipated profits will be considered.

**CANCELLATION**

The performance of work under contract may be terminated by the State in whole, or from time to time in part whenever the State shall determine that such termination is in the best interest of the State. Any such termination shall be effected by delivery to the Contractor of a Notice of Termination specifying the extent to which performance of work under the Contract is terminated and the date upon which such termination becomes effective.

When contracts, or any portion thereof, are terminated before completion of all items of work in the Contract, payment will be made for the actual number of units or items of work completed and accepted at the contract unit price. No claim for loss of anticipated profits will be considered. Reimbursement for organization of the work, when not otherwise included in the Contract, and moving equipment to and from the job will be considered where the volume of work completed and accepted is too small to compensate the Contractor for these expenses under the contract unit prices, the intent being that an equitable settlement will be made with the Contractor.

Termination of the Contract or a portion thereof shall not relieve the Contractor of his responsibilities for the completed work, nor shall it relieve his surety of its obligation for and concerning any just claims arising out of the work performed.

This contract may be cancelled in whole or in part in writing by the Director of Purchasing, without prejudice to any other right or remedy it may have, provided that the contractor is given not less than thirty (30) calendar days written notice, (delivered by certified mail, return receipt requested) of intent to terminate. This contract objective is to comply with the reclamation laws of this state and must be expedient to meet the time requirements for reclamation of revoked surface mine permits.

BUYER CB-23	PAGE 028	REQ. OR PO NO. DEP 14156
SPENDING UNIT WEST VIRGINIA DEPARTMENT OF ENVIRONMENTAL PROTECTION/SPECIAL RECLAMATION		

WV-36a STATE OF WEST VIRGINIA  
 REV. 5-1-08 PURCHASING CONTINUATION SHEET  
 VENDOR:

**S**

Attn:

**A**

Re: Notice to Proceed  
 Permit Name: \_\_\_\_\_  
 Permit No. \_\_\_\_\_  
 Purchase Order No.: DEP

Dear :

**M**

The purpose of this letter is to express our appreciation for your work in advance and to recognize a reclamation partnership project. The official starting date for the above mentioned purchase order is . The work performance period must be completed by . The contract life of one year is provided to accomplish all line items and to process all payments within that period.

**P**

You must schedule a pre-construction conference on site within ten (10) days after receiving this notice to proceed. It is then mandatory that construction begins within ten (10) days of the pre-construction conference and continues diligently until completion of the project. Please contact this office to schedule the pre-construction conference. The foreman, superintendent, or on-the-ground supervisor must be in attendance at this conference.

Failure to comply with this notice to proceed will cause termination of the contract and forfeiture of your performance bond.

**T**

If you have any questions please feel free to contact this office.

Sincerely,

**E**

BUYER CB-23	PAGE 029	REQ. OR PO NO. DEP 14156
SPENDING UNIT WEST VIRGINIA DEPARTMENT OF ENVIRONMENTAL PROTECTION/SPECIAL RECLAMATION		

WV-36a            STATE OF WEST VIRGINIA  
REV. 5-1-08      PURCHASING CONTINUATION SHEET  
VENDOR:

---

## General Requirements

### Project Construction Sign

#### Work Required

The work to be performed under this Section consists of providing all labor, material and equipment necessary to install a project sign as indicated on the detail included herein and as specified herein.

#### Materials

- (a) Paint. Paint for the project sign shall be one (1) coat Exterior-Grade Wood Primer- Sealer, and two (2) coats Exterior-Grade Enamel by Glidden or equivalent.
- (b) Wood. Sign face shall be 3/4" X 4' X 8' Marine Exterior plywood, and posts and cross braces shall be treated.
- (c) Hardware. All hardware shall be manufactured from good, commercial-quality material and be rust resistant such as galvanized coated.

#### Execution

- (a) Project Sign. The signboard shall be cut to the dimensions shown on the details herein. The sign shall be painted with one (1) coat of primer and two (2) coats of white enamel. All exterior cut edges shall be smooth sanded prior to painting. All edges shall be double primed. The letters, border and strips shall be painted as shown on the detail drawing.

The Contractor shall bolt the sign to posts and provide required cross bracing. The posts and sign shall be erected and posts set in gravel base, as shown on the drawings. One (1) sign is required and is to be located at the direction of WVDEP.

- (b) Payment. Payment for the work which shall include installation of the project sign shall be incidental to the lump sum bid item for "Mobilization/Demobilization"

Note: No construction work shall commence prior to the project sign being installed.



Joe Manchin, III  
Governor



Randy C. Huffiman,  
Cabinet Secretary



Ken Ellison,  
Director

STATE OF WEST VIRGINIA  
DEPARTMENT OF ENVIRONMENTAL PROTECTION

Division of Land Restoration  
Office of Special Reclamation

Project Cost: \$XXX,XXX.00  
Funding provided by the Special Reclamation Coal Tax paid by WV Coal Mine Companies

Permit Name  
Permit Number

Contractor: Joe Smith Contracting

Project Start Date: 01/01/01

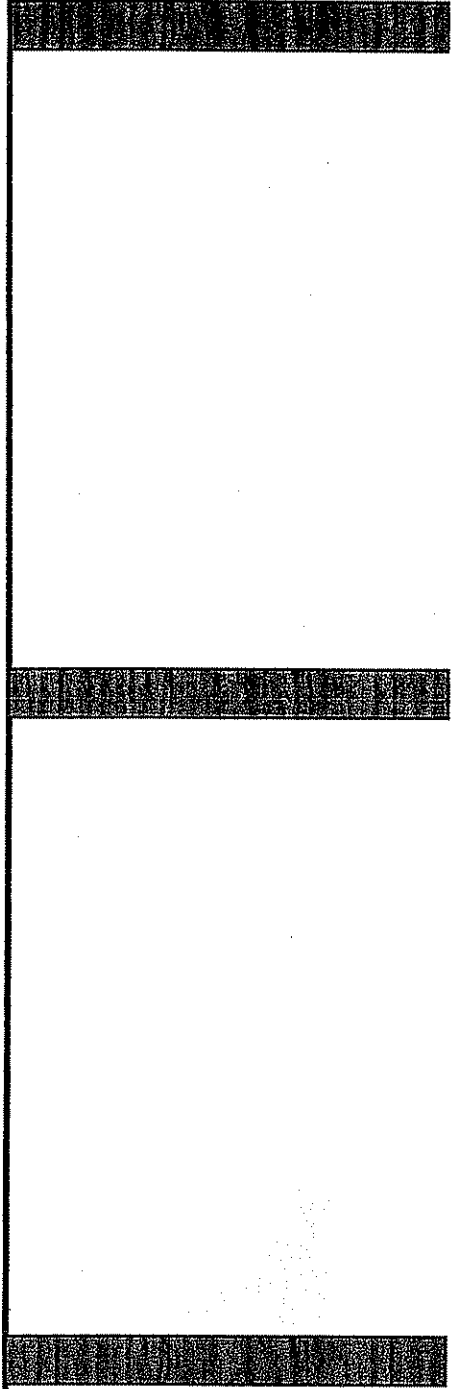

77 1/4"

27 3/4"

STATE OF WEST VIRGINIA  
DEPARTMENT OF ENVIRONMENTAL PROTECTION

Division of Land Restoration  
Office of Special Reclamation

Project Cost: \$XXX,XXX.00  
Funding provided by the Special Reclamation Coal Tax paid by WV Coal Mine Companies

Permit Name  
Permit Number

Project Start Date: 01/01/01

Contractor: Joe Smith Contracting

17 1/4"

1 1/2"

1 1/8"

15 3/4"

7 7/8"

3 3/4"

7 7/8"

3"

8 5/8"



Joe Manchin, III  
Governor



Randy C. Huffman,  
Cabinet Secretary



Ken Ellison,  
Director

18"

2 1/4"

73 7/8"

36"

36"

48"

6"

6"



96"



STATE OF WEST VIRGINIA  
DEPARTMENT OF ENVIRONMENTAL PROTECTION

Division of Land Restoration  
Office of Special Reclamation

Joe Manchin, III  
Governor

48"

Project Cost: \$XXX,XXX.00  
Funding provided by the Special Reclamation Coal Tax paid by WV Coal Mine Companies



Randy C. Huffman,  
Cabinet Secretary



Ken Ellison,  
Director

Permit Name  
Permit Number

Contractor: Joe Smith Contracting

Project Start Date: 01/01/01

7 7/8"

9 3/8"

5 1/2"

81 3/8"

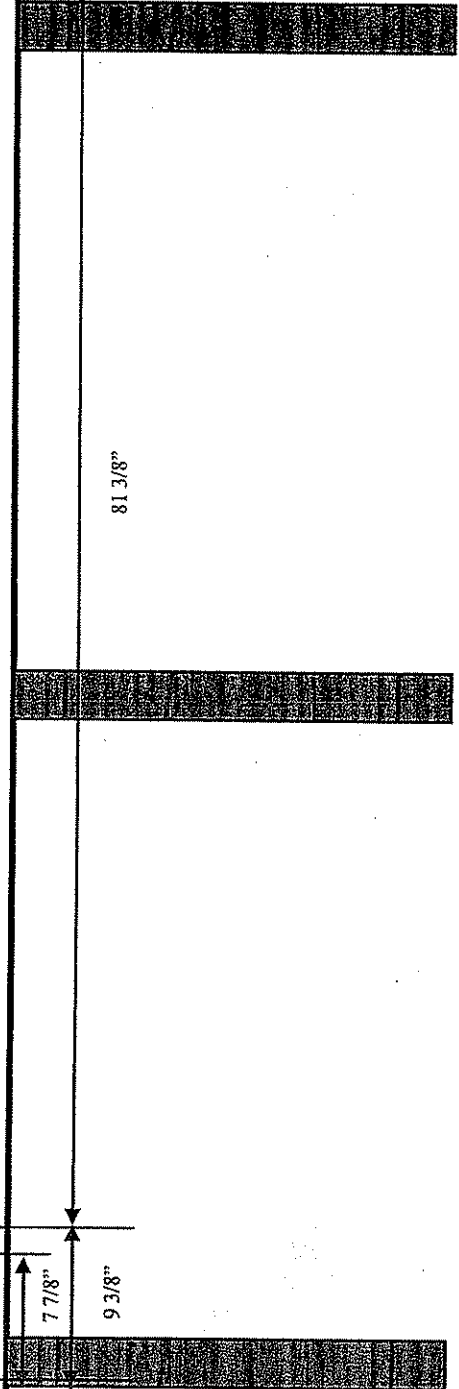

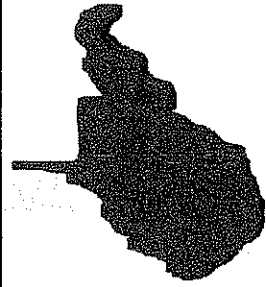

STATE OF WEST VIRGINIA  
DEPARTMENT OF ENVIRONMENTAL PROTECTION

Joe Manchin, III  
Governor



Randy C. Huffman  
Cabinet Secretary



Ken Ellison  
Director

Division of Land Restoration  
Office of Special Reclamation

Project Cost: \$XXX,XXX.00

Funding provided by the Special Reclamation Coal Tax paid by WY Coal Mine Companies

Permit Name

Permit Number

Contractor: Joe Smith Contracting  
Project Start Date: 01/01/01

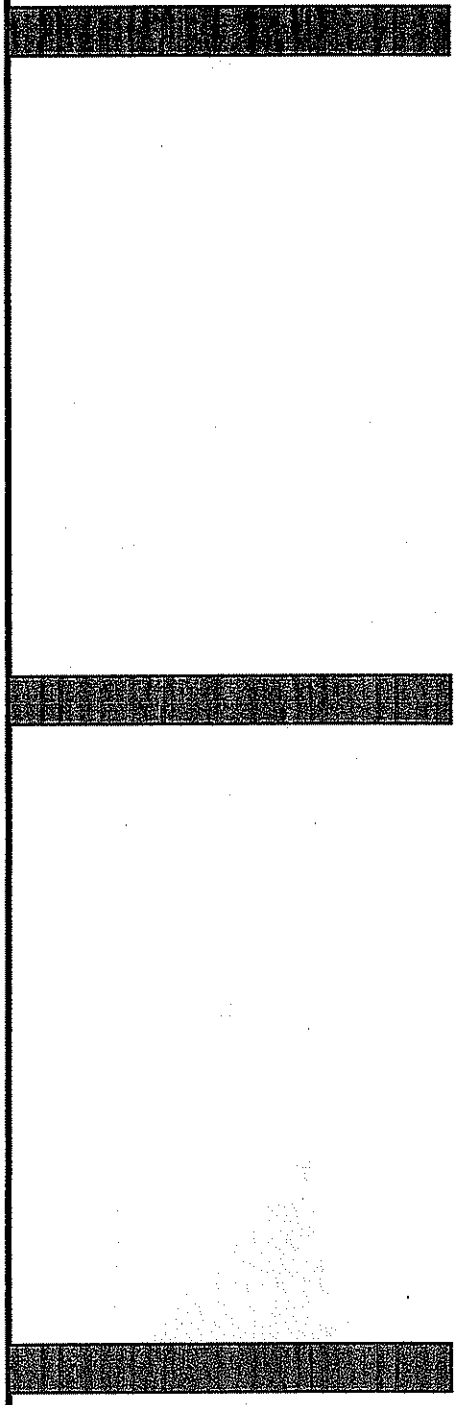
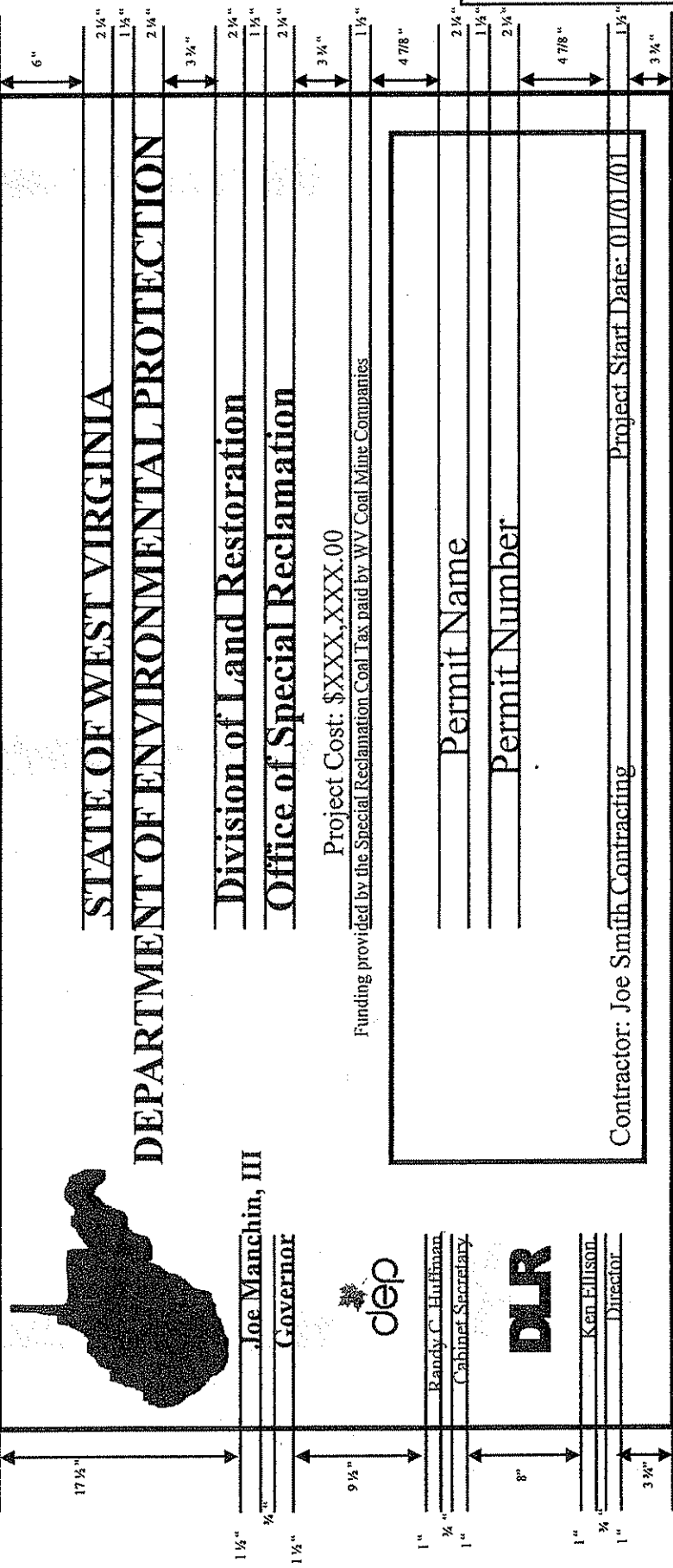

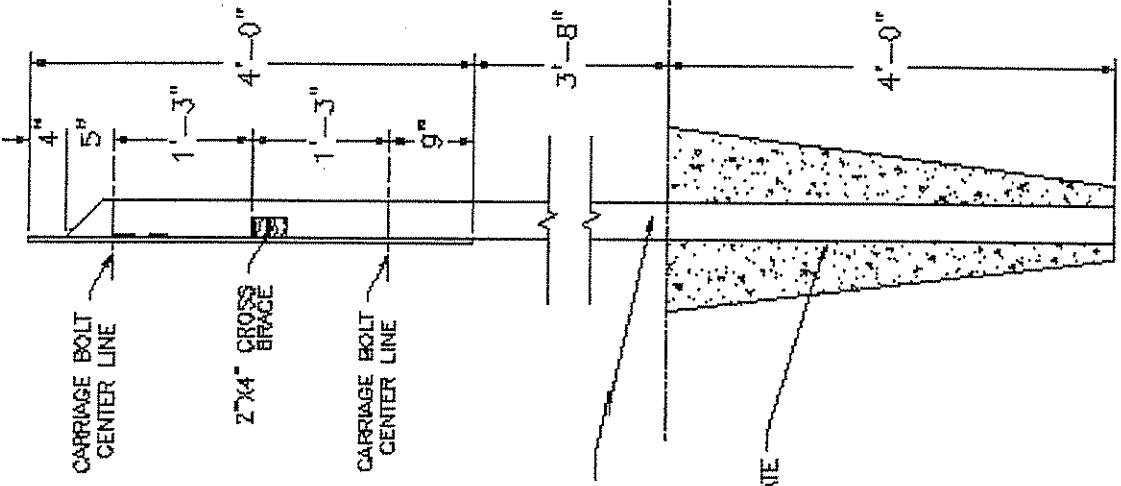

- NOTES:**
- 1.) SIGN BOARD TO BE 3/4" x 4' x 8' MARINE PLYWOOD.
  - 2.) SIGN BOARD COLOR IS WHITE AND LETTER COLORS ARE DARK GREEN.
  - 3.) TREATED 2" x 4" CROSS BRACE LET INTO POSTS.
  - 4.) MOUNT SIGN TO POSTS USING 3/8" x 5" GALVANIZED CARRIAGE BOLTS.
  - 5.) USE 4" x 4" x 12' TREATED POSTS.
  - 6.) LOCATION DETERMINED BY WVDEP.

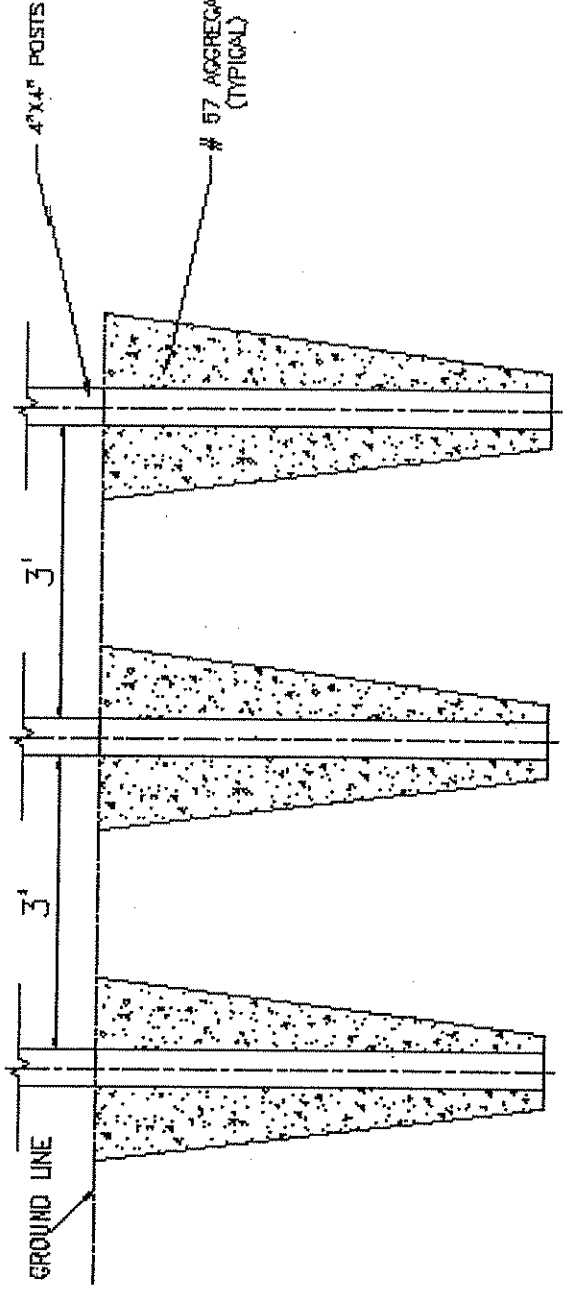

PROJECT SIGN  
NOT TO SCALE

BUFFALO - S-2003-03  
SITE PLAN

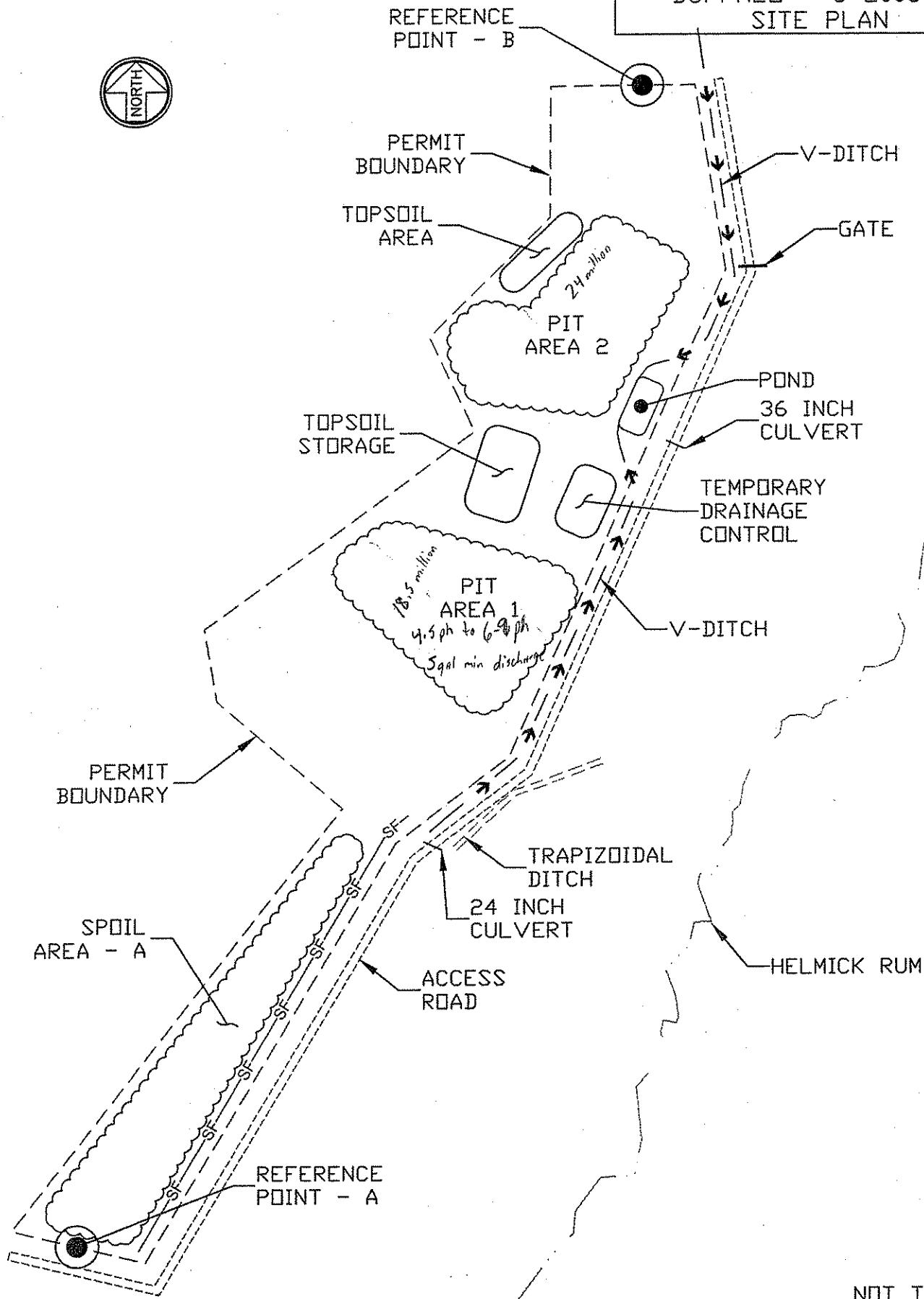

NOT TO SCALE

SPILL CONTAINMENT

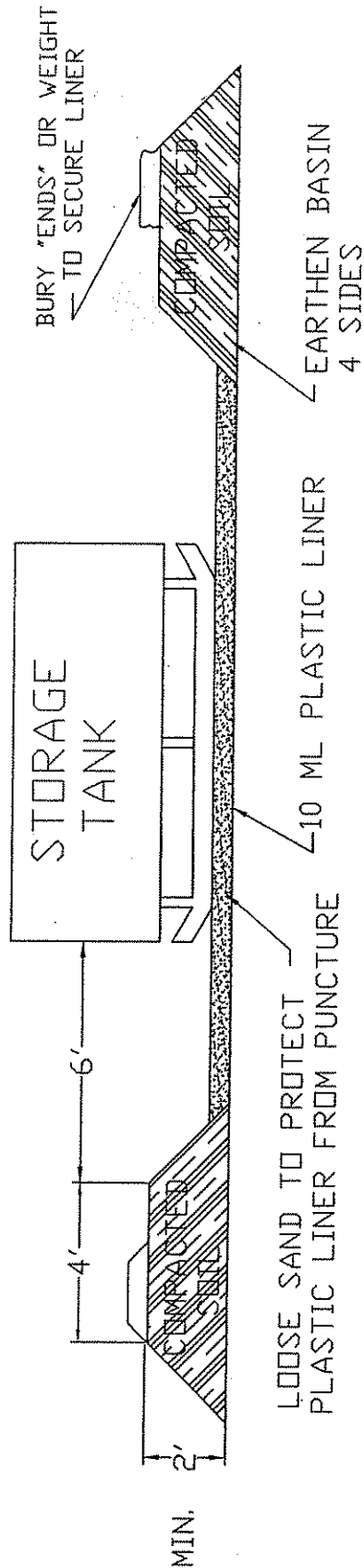

SELECTED HEIGHT OF EARTHEN BERM IS TO BE A TWO (2') FOOT MINIMUM OR ONE HUNDRED TEN PERCENT (110%) OF THE CAPACITY OF THE TANK(S) TOTAL VOLUME WITHIN THE BERM. A SIX (6") INCH FREEBOARD MUST BE INCLUDED.

NOTE: A TWO INCH (2") WATER REMOVAL DRAIN SHALL BE LOCATED AT THE LOWEST POINT IN THE BOTTOM OF THE CONTAINMENT VOLUME. IT SHALL CONNECT TO A NORMALLY CLOSED VALVE OUTSIDE THE DIKE. THE VALVE SHALL BE MANUALLY OPERATED AND PROTECTED FROM UNAUTHORIZED OPERATION. RAINWATER CONTAINED WITHIN THIS DIKE SHALL BE EXAMINED PRIOR TO RELEASE TO ENSURE THAT HARMFUL QUANTITIES OF FUELS AND LUBRICANTS ARE NOT DISCHARGED. ALTERNATE METHODS OF WATER REMOVAL WILL BE CONSIDERED FOR APPROVAL.

TANKS WITH SECONDARY CONTAINMENT MAY BE USED AS AN ALTERNATIVE.

SILT FENCE INSTALLATION

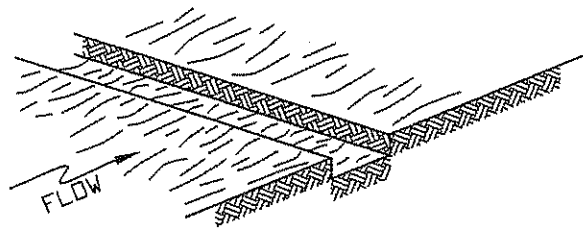

1. EXCAVATE 6' X 6' TRENCH

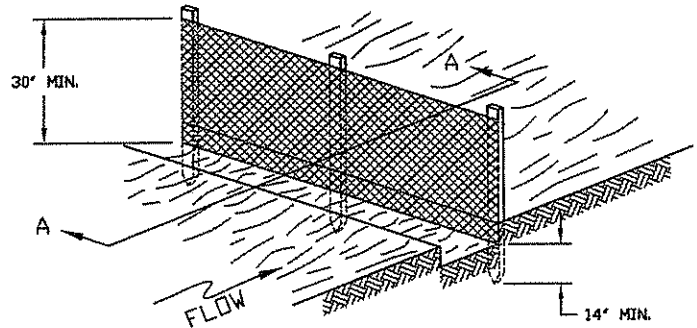

2. PLACE FENCE AT BACK EDGE OF TRENCH (FABRIC FACING DIRECTION OF FLOW)

3. DRIVE POST UNTIL FABRIC REACHES BOTTOM OF TRENCH

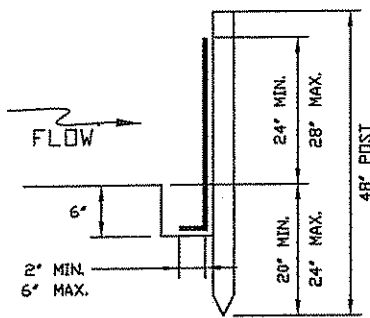

SECTION A-A

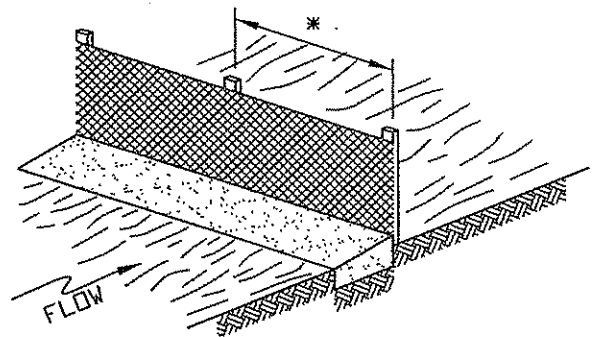

\* SEE SPECIFICATIONS FOR REQUIRED POST SPACING.

4. FILL TRENCH WITH EMBANKMENT & TAMP

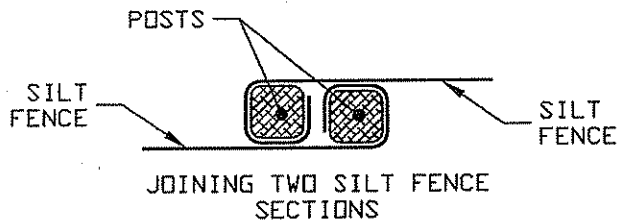

NOTE: WHEN MORE THAN ONE ROLL OF SILT FENCE IS USED, THE FENCE AT THE JUNCTION MUST BE PLACED SO THAT THE LAST POST OF THE FIRST RUN & THE FIRST POST OF THE SECOND RUN OVERLAP & ARE TIED TOGETHER.

HAY/STRAW BALE DIKE  
SEDIMENT CONTROL

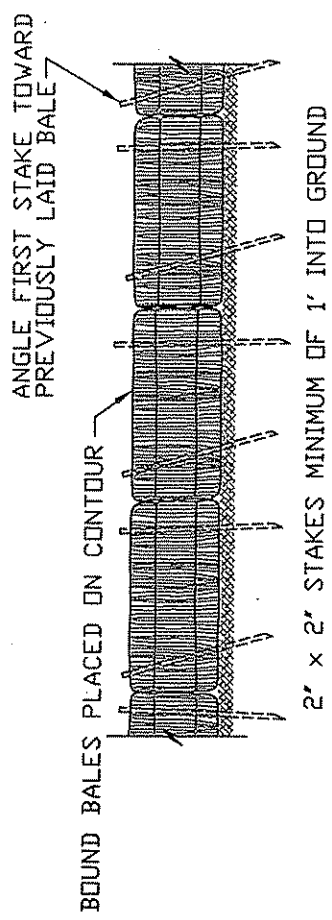

ANCHORING DETAIL

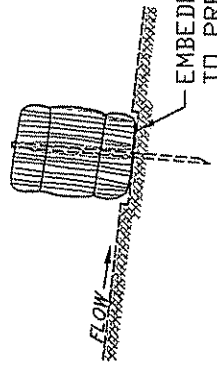

END VIEW

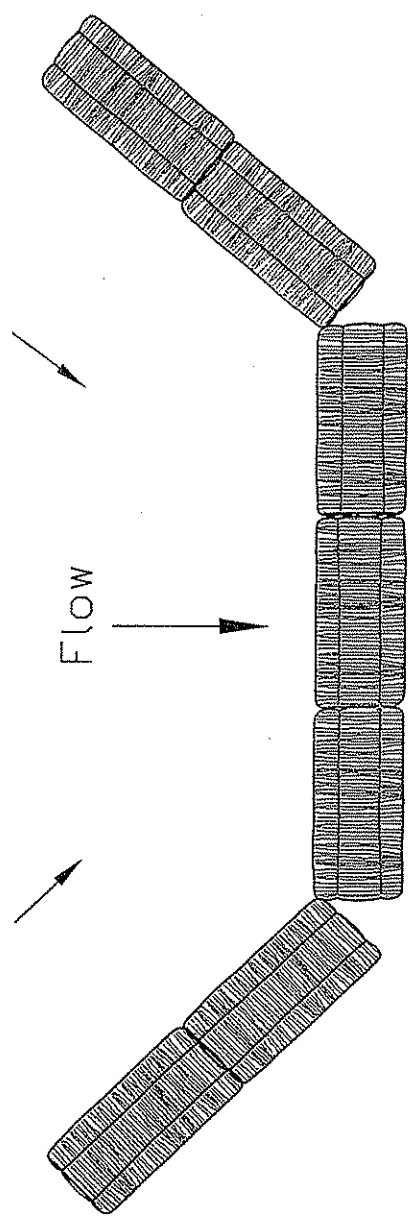

DESIGN TO FIT SITE CONDITIONS

SEDIMENT BARRIER  
TOP VIEW

NOT TO SCALE

ACCESS ROAD UPGRADE

ACCESS ROAD UPGRADE

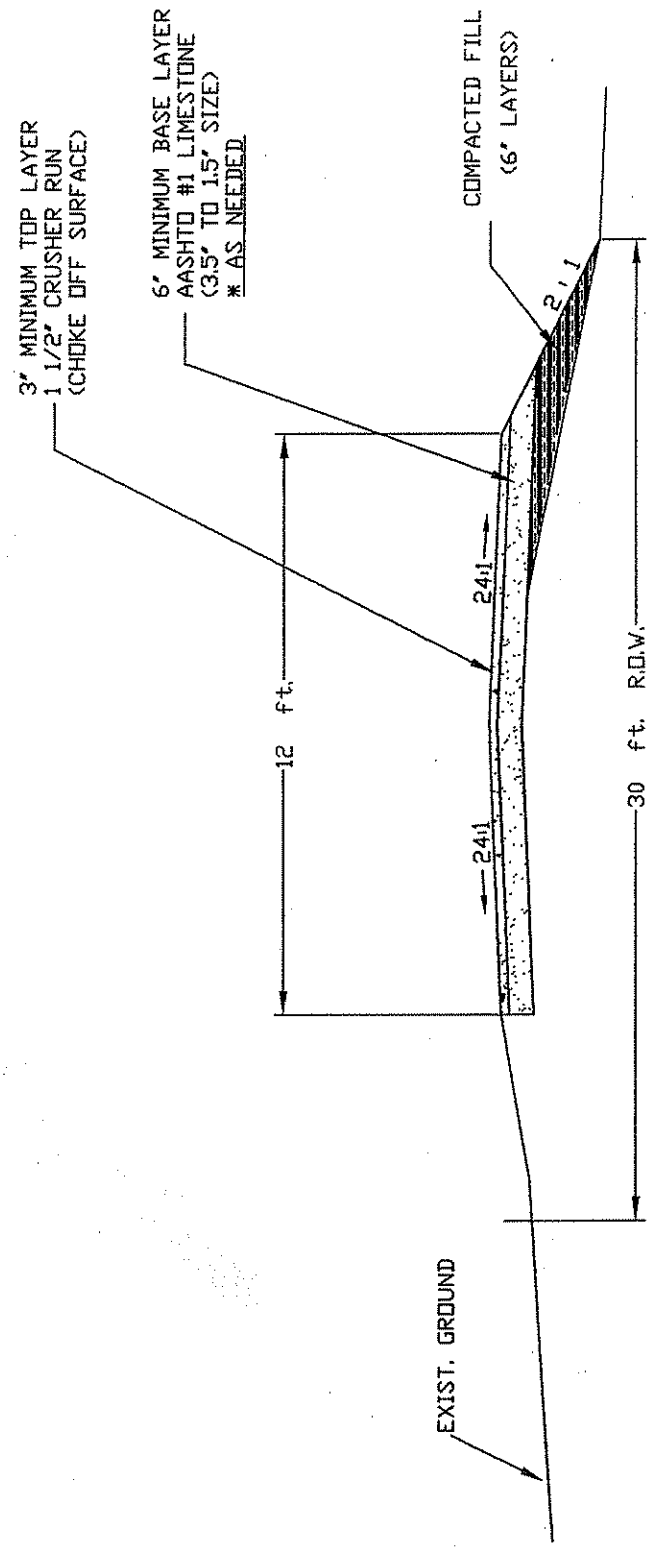

TYPICAL SECTION

- NOTES:
- THE EXISTING ROAD SHALL BE REGRADED, SHAPED, AND ROCKED AS NECESSARY TO MEET THESE SPECIFICATIONS.
  - ANY TREES OR BRUSH WITHIN THE 30 FEET R.O.W. OF THE ROAD SHALL BE REMOVED.
  - ANY OVERHANGING TREE LIMBS IN THE R.O.W. AT A HEIGHT OF 15 FEET OR LESS SHALL BE REMOVED.



CULVERT INSTALLATION

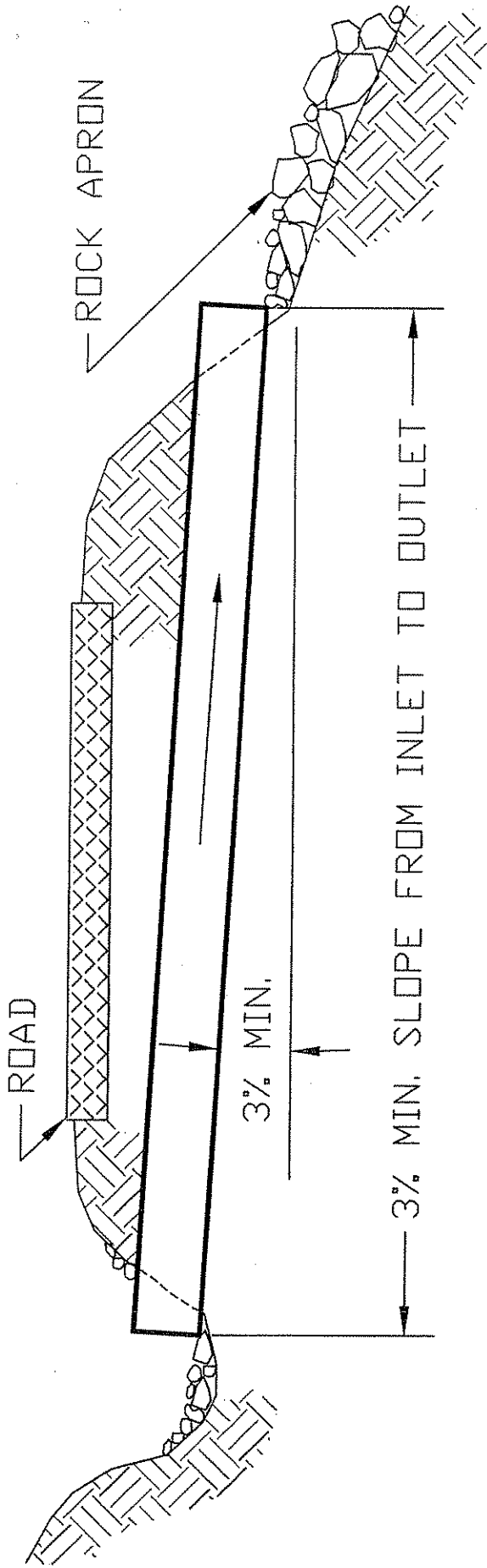

EARTHEN DIKE TO BE INSTALLED IN DITCH  
LINE BELOW CULVERT INLET

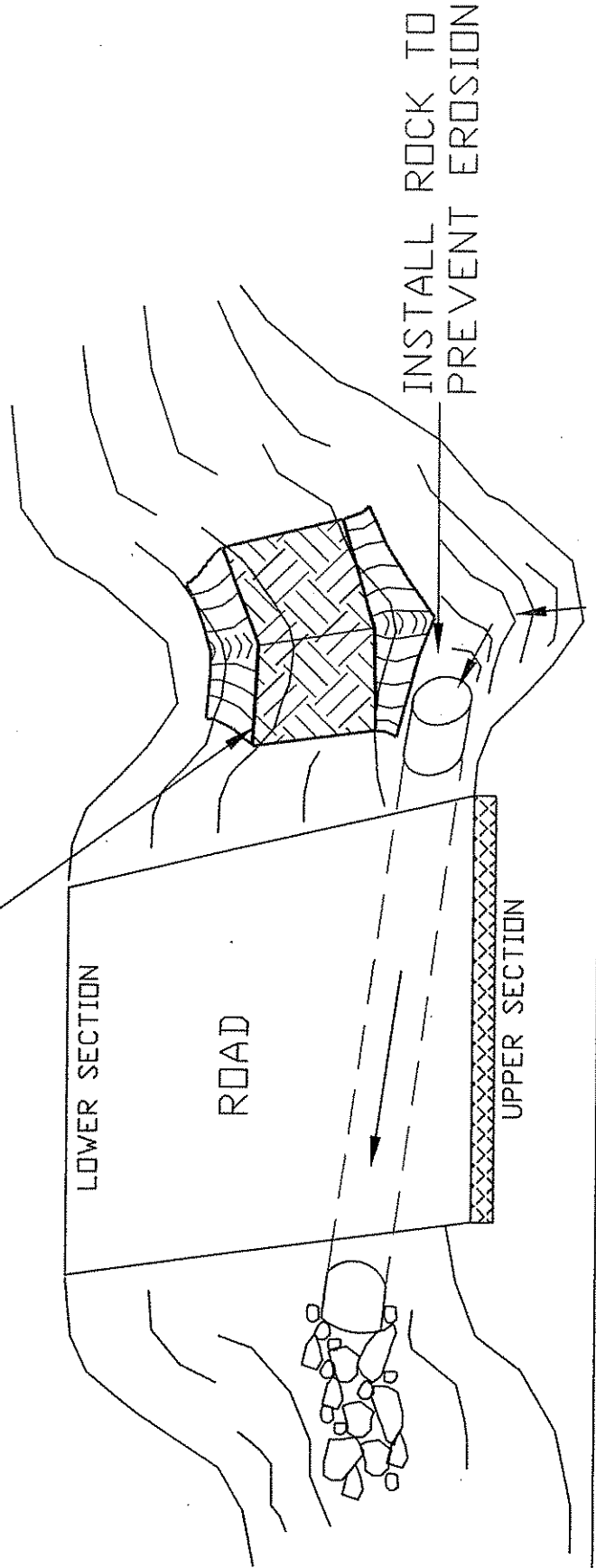

CULVERT INSTALLATION

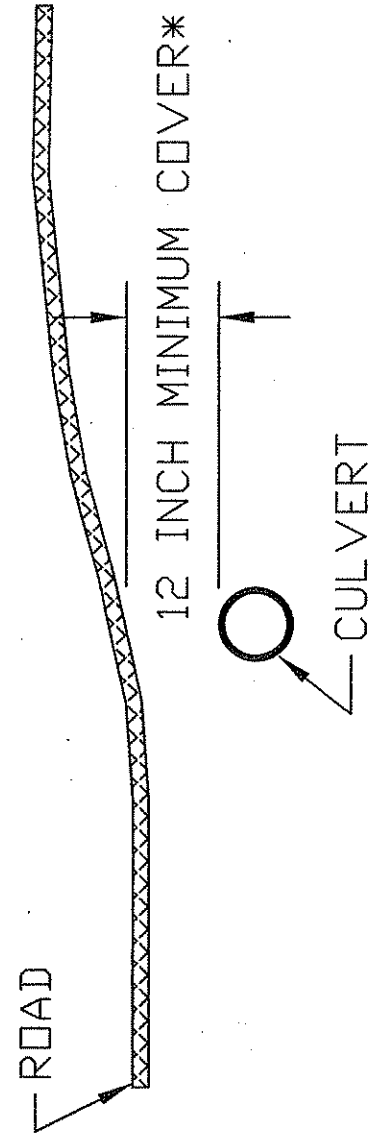
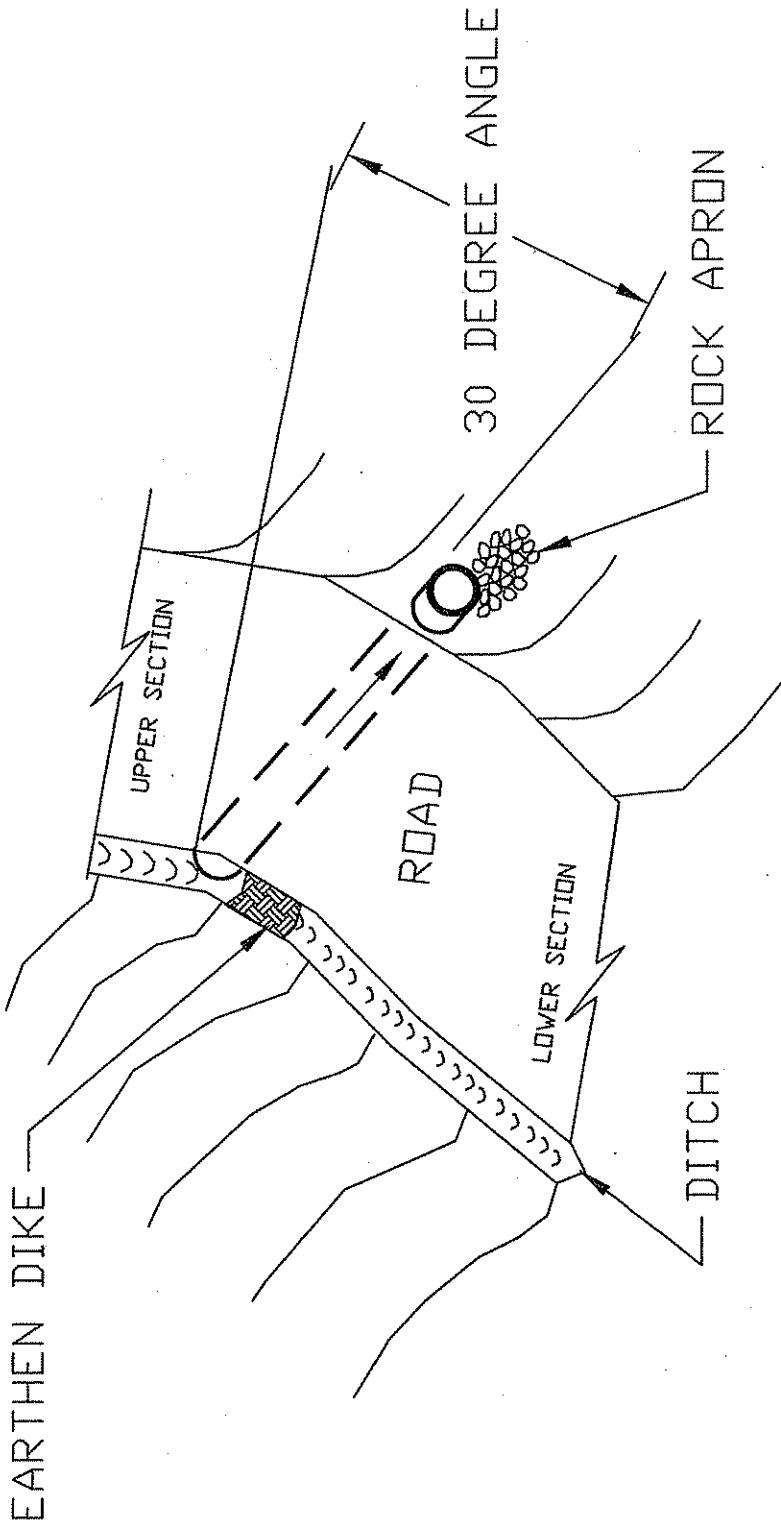

\*OR 1/2 CULVERT DIAMETER, WHICHEVER IS GREATER.

V - DITCH 4' WIDE

V - DITCH

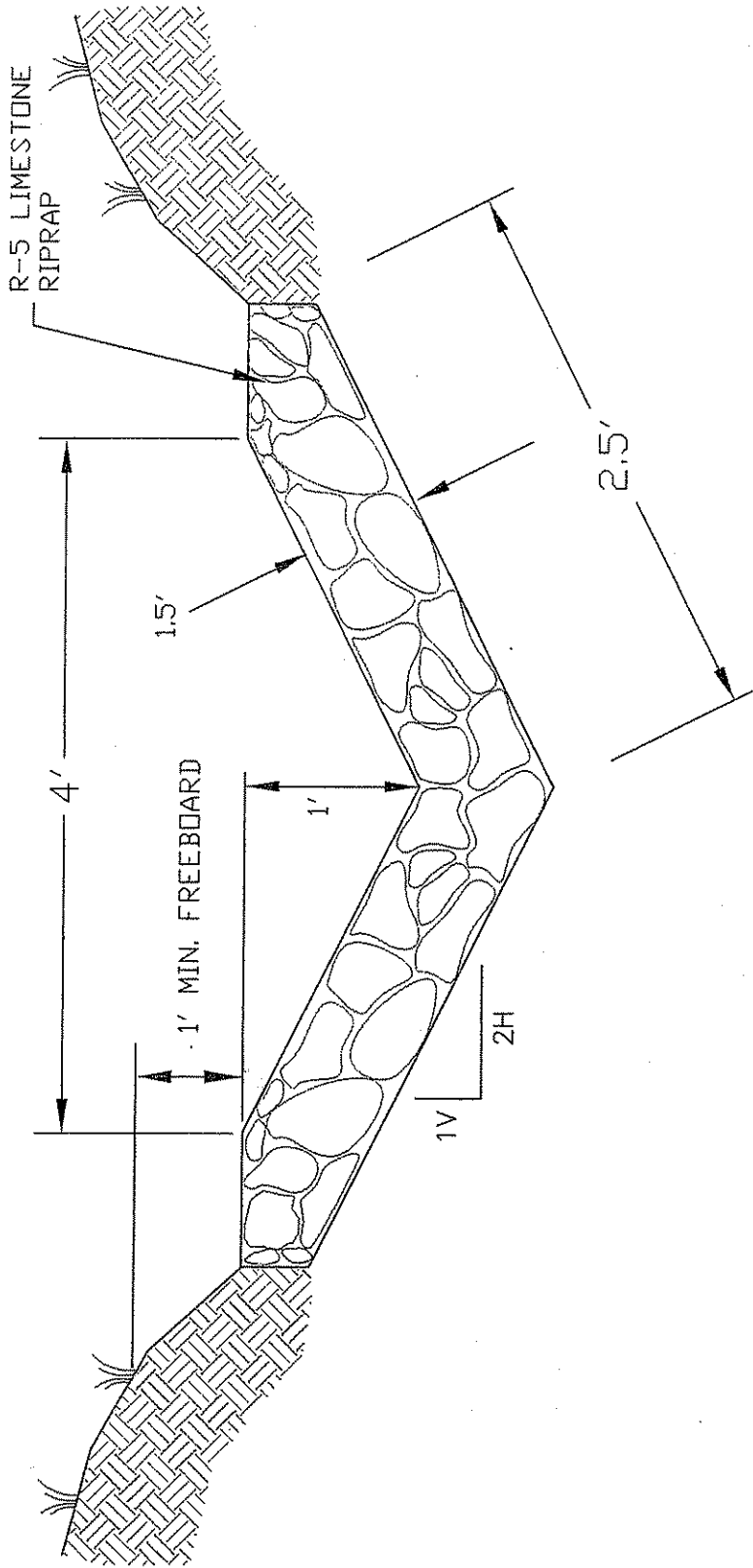

NOT TO SCALE

PAYMENT SHALL BE FOR ACTUAL LENGTH OF DITCH CONSTRUCTED.

R-5 LIMESTONE RIPRAP (STANDARD) UNLESS OTHERWISE NOTED, RIPRAP SHALL BE DURABLE ROCK PLACED IN A 15 FOOT BLANKET. TWENTY-FIVE (25%) OF THE ROCK WILL BE OF 18 INCHES OR LARGER, THE REMAINING SEVENTY-FIVE (75%) SHALL BE WELL GRADED MATERIAL (MINIMUM 3 INCHES TO MAXIMUM 15 INCHES) OF SUFFICIENT ROCK SMALL ENOUGH TO FILL THE VOIDS BETWEEN THE LARGER ROCK. SHALE SHALL NOT BE USED FOR RIPRAP. IF RIPRAP STABILITY IS QUESTIONABLE, DURABILITY SHALL BE DETERMINED BY THE SODIUM SULPHATE TEST ASTM C 88/AASHTO T 104-77.

TRAPEZOIDAL - DITCH

TRAPEZOIDAL - DITCH

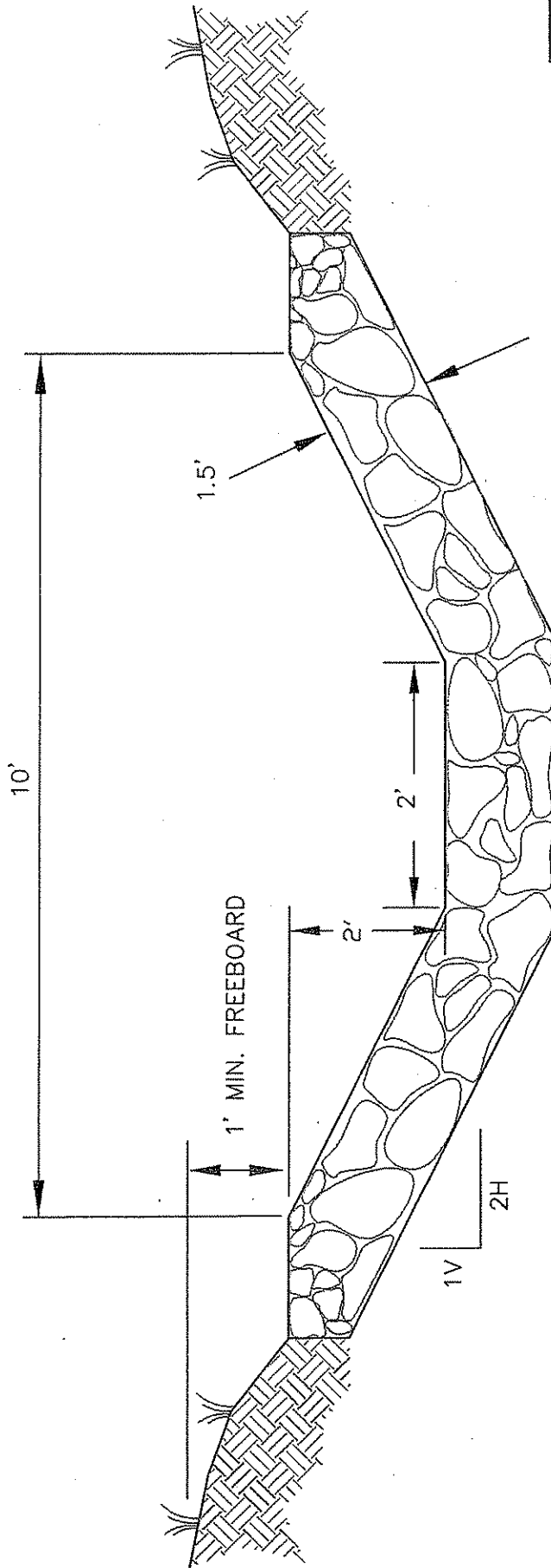

NOT TO SCALE

PAYMENT SHALL BE FOR ACTUAL LENGTH OF DITCH CONSTRUCTED.

R-5 LIMESTONE RIPRAP (STANDARD) UNLESS OTHERWISE NOTED, RIPRAP SHALL BE DURABLE ROCK PLACED IN A 1.5 FOOT BLANKET. TWENTY-FIVE (25%) OF THE ROCK WILL BE OF 18 INCHES OR LARGER, THE REMAINING SEVENTY-FIVE (75%) SHALL BE WELL GRADED MATERIAL (MINIMUM 3 INCHES TO MAXIMUM 15 INCHES) OF SUFFICIENT ROCK SMALL ENOUGH TO FILL THE VOIDS BETWEEN THE LARGER ROCK. SHALE SHALL NOT BE USED FOR RIPRAP. IF RIPRAP STABILITY IS QUESTIONABLE, DURABILITY SHALL BE DETERMINED BY THE SODIUM SULPHATE TEST ASTM C 88/AASHTO T 104-77.

STATE OF WEST VIRGINIA  
Purchasing Division

**PURCHASING AFFIDAVIT**

**VENDOR OWING A DEBT TO THE STATE:**

*West Virginia Code* §5A-3-10a provides that: No contract or renewal of any contract may be awarded by the state or any of its political subdivisions to any vendor or prospective vendor when the vendor or prospective vendor or a related party to the vendor or prospective vendor is a debtor and the debt owed is an amount greater than one thousand dollars in the aggregate.

**PUBLIC IMPROVEMENT CONTRACTS & DRUG-FREE WORKPLACE ACT:**

If this is a solicitation for a public improvement construction contract, the vendor, by its signature below, affirms that it has a written plan for a drug-free workplace policy in compliance with Article 1D, Chapter 21 of the *West Virginia Code*. The vendor **must** make said affirmation with its bid submission. Further, public improvement construction contract may not be awarded to a vendor who does not have a written plan for a drug-free workplace policy in compliance with Article 1D, Chapter 21 of the *West Virginia Code* and who has not submitted that plan to the appropriate contracting authority in timely fashion. For a vendor who is a subcontractor, compliance with Section 5, Article 1D, Chapter 21 of the *West Virginia Code* may take place before their work on the public improvement is begun.

**ANTITRUST:**

In submitting a bid to any agency for the state of West Virginia, the bidder offers and agrees that if the bid is accepted the bidder will convey, sell, assign or transfer to the state of West Virginia all rights, title and interest in and to all causes of action it may now or hereafter acquire under the antitrust laws of the United States and the state of West Virginia for price fixing and/or unreasonable restraints of trade relating to the particular commodities or services purchased or acquired by the state of West Virginia. Such assignment shall be made and become effective at the time the purchasing agency tenders the initial payment to the bidder.

I certify that this bid is made without prior understanding, agreement, or connection with any corporation, firm, limited liability company, partnership or person or entity submitting a bid for the same materials, supplies, equipment or services and is in all respects fair and without collusion or fraud. I further certify that I am authorized to sign the certification on behalf of the bidder or this bid.

**LICENSING:**

Vendors must be licensed and in good standing in accordance with any and all state and local laws and requirements by any state or local agency of West Virginia, including, but not limited to, the West Virginia Secretary of State's Office, the West Virginia Tax Department, West Virginia Insurance Commission, or any other state agencies or political subdivision. Furthermore, the vendor must provide all necessary releases to obtain information to enable the Director or spending unit to verify that the vendor is licensed and in good standing with the above entities.

**CONFIDENTIALITY:**

The vendor agrees that he or she will not disclose to anyone, directly or indirectly, any such personally identifiable information or other confidential information gained from the agency, unless the individual who is the subject of the information consents to the disclosure in writing or the disclosure is made pursuant to the agency's policies, procedures and rules. Vendor further agrees to comply with the Confidentiality Policies and Information Security Accountability Requirements, set forth in <http://www.state.wv.us/admin/purchase/privacy/noticeConfidentiality.pdf>.

Under penalty of law for false swearing (*West Virginia Code* §61-5-3), it is hereby certified that the vendor affirms and acknowledges the information in this affidavit and is in compliance with the requirements as stated.

Vendor's Name: Pineville Paving & Excavating Inc.

Authorized Signature: Kevin D. Baulf Date: 6-18-09



State of West Virginia  
DRUG FREE WORKPLACE CONFORMANCE AFFIDAVIT  
West Virginia Code §21-1D-5

STATE OF West Virginia

COUNTY OF Wyoming, TO-WIT:

I, Kevin D Bradford after being first duly sworn, depose and state as follows:

1. I am an employee of Pineville Paving & Excavating Inc.; and,  
(Company Name)

2. I do hereby attest that Pineville Paving & Excavating Inc.  
(Company Name)

maintains a valid written drug free workplace policy and that such policy is in compliance with **West Virginia Code §21-1D-5**.

The above statements are sworn to under the penalty of perjury.

Pineville Paving & Excavating Inc.  
(Company Name)

By: Kevin D Bradford

Title: Vice President

Date: 6-18-09

Taken, subscribed and sworn to before me this 18<sup>th</sup> day of June.

By Commission Expires February 20, 2019

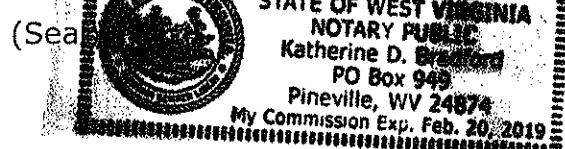

Katherine D. Bradford  
(Notary Public)

**THIS AFFIDAVIT MUST BE SUBMITTED WITH THE BID IN ORDER TO COMPLY WITH WV CODE PROVISIONS. FAILURE TO INCLUDE THE AFFIDAVIT WITH THE BID SHALL RESULT IN DISQUALIFICATION OF THE BID.**

BID BOND

KNOW ALL MEN BY THESE PRESENTS, That we, the undersigned, \_\_\_\_\_  
of \_\_\_\_\_, \_\_\_\_\_, as Principal, and \_\_\_\_\_  
of \_\_\_\_\_, \_\_\_\_\_, a corporation organized and existing under the laws of the State of \_\_\_\_\_  
with its principal office in the City of \_\_\_\_\_, as Surety, are held and firmly bound unto the State  
of West Virginia, as Obligee, in the penal sum of \_\_\_\_\_ (\$ \_\_\_\_\_) for the payment of which,  
well and truly to be made, we jointly and severally bind ourselves, our heirs, administrators, executors, successors and assigns.

The Condition of the above obligation is such that whereas the Principal has submitted to the Purchasing Section of the  
Department of Administration a certain bid or proposal, attached hereto and made a part hereof, to enter into a contract in writing for  
\_\_\_\_\_  
\_\_\_\_\_  
\_\_\_\_\_

NOW THEREFORE,

- (a) If said bid shall be rejected, or
- (b) If said bid shall be accepted and the Principal shall enter into a contract in accordance with the bid or proposal attached  
hereto and shall furnish any other bonds and insurance required by the bid or proposal, and shall in all other respects perform the  
agreement created by the acceptance of said bid, then this obligation shall be null and void, otherwise this obligation shall remain in full  
force and effect. It is expressly understood and agreed that the liability of the Surety for any and all claims hereunder shall, in no event,  
exceed the penal amount of this obligation as herein stated.

The Surety, for the value received, hereby stipulates and agrees that the obligations of said Surety and its bond shall be in no  
way impaired or affected by any extension of the time within which the Obligee may accept such bid, and said Surety does hereby  
waive notice of any such extension.

IN WITNESS WHEREOF, Principal and Surety have hereunto set their hands and seals, and such of them as are corporations  
have caused their corporate seals to be affixed hereunto and these presents to be signed by their proper officers, this  
\_\_\_\_\_ day of \_\_\_\_\_, 20\_\_\_\_\_.

Principal Corporate Seal

\_\_\_\_\_  
(Name of Principal)

By \_\_\_\_\_  
(Must be President or  
Vice President)

\_\_\_\_\_  
(Title)

Surety Corporate Seal

\_\_\_\_\_  
(Name of Surety)

\_\_\_\_\_  
Attorney-in-Fact

**IMPORTANT – Surety executing bonds must be licensed in West Virginia to transact surety insurance. Raised corporate seals  
must be affixed, a power of attorney must be attached.**

AGENCY \_\_\_\_\_ (A)  
 RFQ/RFP# \_\_\_\_\_ (B)

**Bid Bond**

- (A) WV State Agency  
(Stated on Page 1 "Spending Unit")  
Request for Quotation Number (upper right corner of page #1)
- (C) Your Company Name
- (D) City, Location of your Company
- (E) State, Location of your Company
- (F) Surety Corporate Name
- (G) City, Location of Surety
- (H) State, Location of Surety
- (I) State of Surety Incorporation
- (J) City of Surety Incorporation
- (K) Minimum amount of acceptable bid bond is 5% of total bid. You may state "5% of bid" or a specific amount on this line in words.
- (L) Amount of bond in figures
- (M) Brief Description of scope of work
- (N) Day of the month
- (O) Month
- (P) Year
- (Q) Name of Corporation
- (R) Raised Corporate Seal of Principal
- (S) Signature of President or Vice President
- (T) Title of person signing
- (U) Raised Corporate Seal of Surety
- (V) Corporate Name of Surety
- (W) Signature of Attorney in Fact of the Surety

NOTE: Dated, Power of Attorney with Raised Surety Seal must accompany this bid bond.

KNOW ALL MEN BY THESE PRESENTS, That we, the undersigned, \_\_\_\_\_ (C) of \_\_\_\_\_ (D), \_\_\_\_\_ (E) as Principal, and \_\_\_\_\_ (F) of \_\_\_\_\_ (G), \_\_\_\_\_ (H), a corporation organized and existing under the laws of the State of \_\_\_\_\_ (I) with its principal office in the City of \_\_\_\_\_ (J), as Surety, are held and firmly bound unto The State of West Virginia, as Obligee, in the penal sum of \_\_\_\_\_ (K) (\$ \_\_\_\_\_ (L)) for the payment of which, well and truly to be made, we jointly and severally bind ourselves, our heirs, administrators, executors, successors and assigns.

The Condition of the above obligation is such that whereas the Principal has submitted to the Purchasing Section of the Department of Administration a certain bid or proposal, attached hereto and made a part hereof to enter into a contract in writing for \_\_\_\_\_ (M)

NOW THEREFORE.

(a) If said bid shall be rejected, or  
 (b) If said bid shall be accepted and the Principal shall enter into a contract in accordance with the bid or proposal attached hereto and shall furnish any other bonds and insurance required by the bid or proposal, and shall in all other respects perform the agreement created by the acceptance of said bid then this obligation shall be null and void, otherwise this obligation shall remain in full force and effect. It is expressly understood and agreed that the liability of the Surety for any and all claims hereunder shall, in no event, exceed the penal amount of this obligation as herein stated

The Surety for value received, hereby stipulates and agrees that the obligations of said Surety and its bond shall be in no way impaired or affected by any extension of time within which the Obligee may accept such bid: and said Surety does hereby waive notice of any such extension.

IN WITNESS WHEREOF, Principal and Surety have hereunto set their hands and seals, and such of them as are corporations have caused their corporate seals to be affixed hereto and these presents to be signed by their proper officers, this \_\_\_\_\_ (N) day of \_\_\_\_\_ (O), 20 \_\_\_\_\_ (P).

Principal Corporate Seal \_\_\_\_\_ (O)  
 (Name of Principal)  
 By \_\_\_\_\_ (S)  
 (Must be President or Vice President)  
 \_\_\_\_\_ (T)  
 Title  
 \_\_\_\_\_ (U)  
 Surety Corporate Seal \_\_\_\_\_ (V)  
 (Name of Surety)  
 \_\_\_\_\_ (W)  
 Attorney-in-Fact

**IMPORTANT** – Surety executing bonds must be licensed in West Virginia to transact surety insurance. Raised Corporate Seals must be affixed and a Power of Attorney must be attached.



**BID BOND**

KNOW ALL MEN BY THESE PRESENTS, That we, the undersigned, Pineville Paving & Excavating, Inc  
of PO Box 1290 Pineville, WV 25874, as Principal, and Ohio Farmers Insurance Company  
of One Park Circle Westfield Center OH, a corporation organized and existing under the laws of the State of Ohio  
with its principal office in the City of Westfield Center, as Surety, are held and firmly bound unto the State  
of West Virginia, as Obligee, in the penal sum of Five Percent (\$ 5%) for the payment of which,  
well and truly to be made, we jointly and severally bind ourselves, our heirs, administrators, executors, successors and assigns.

The Condition of the above obligation is such that whereas the Principal has submitted to the Purchasing Section of the  
Department of Administration a certain bid or proposal, attached hereto and made a part hereof, to enter into a contract in writing for  
DEP14156, Buffalo Coal Company, Inc. in Grant County, according to plans and specifications.

NOW THEREFORE,

- (a) If said bid shall be rejected, or
- (b) If said bid shall be accepted and the Principal shall enter into a contract in accordance with the bid or proposal attached hereto and shall furnish any other bonds and insurance required by the bid or proposal, and shall in all other respects perform the agreement created by the acceptance of said bid, then this obligation shall be null and void, otherwise this obligation shall remain in full force and effect. It is expressly understood and agreed that the liability of the Surety for any and all claims hereunder shall, in no event, exceed the penal amount of this obligation as herein stated.

The Surety, for the value received, hereby stipulates and agrees that the obligations of said Surety and its bond shall be in no way impaired or affected by any extension of the time within which the Obligee may accept such bid, and said Surety does hereby waive notice of any such extension.

IN WITNESS WHEREOF, Principal and Surety have hereunto set their hands and seals, and such of them as are corporations have caused their corporate seals to be affixed hereunto and these presents to be signed by their proper officers, this  
17th day of June, 2009.

Principal Corporate Seal

Pineville Paving & Excavating, Inc  
(Name of Principal)

By Kevin D Bradford  
Kevin Bradford (Must be President or Vice President)

Vice President  
(Title)

Surety Corporate Seal

Ohio Farmers Insurance Company  
(Name of Surety)

Ross E. Johnson  
Ross E. Johnson Attorney-in-Fact

IMPORTANT – Surety executing bonds must be licensed in West Virginia to transact surety insurance. Corporate seals must be affixed, and a power of attorney must be attached.

General  
Power  
of Attorney

POWER NO. 4751892 01

**Westfield Insurance Co.  
Westfield National Insurance Co.  
Ohio Farmers Insurance Co.**  
Westfield Center, Ohio

CERTIFIED COPY

Know All Men by These Presents, That WESTFIELD INSURANCE COMPANY, WESTFIELD NATIONAL INSURANCE COMPANY and OHIO FARMERS INSURANCE COMPANY, corporations, hereinafter referred to individually as a "Company" and collectively as "Companies," duly organized and existing under the laws of the State of Ohio, and having its principal office in Westfield Center, Medina County, Ohio, do by these presents make, constitute and appoint  
**ROSS E. JOHNSON, H. RANDOLPH NEVILLE, PATRICK B. KEE, SHEILA D. MCCORMICK, JOINTLY OR SEVERALLY**

of CHARLESTON and State of WV its true and lawful Attorney(s)-in-Fact, with full power and authority hereby conferred in its name, place and stead, to execute, acknowledge and deliver any and all bonds, recognizances, undertakings, or other instruments or contracts of suretyship-

**LIMITATION: THIS POWER OF ATTORNEY CANNOT BE USED TO EXECUTE NOTE GUARANTEE, MORTGAGE DEFICIENCY, MORTGAGE GUARANTEE, OR BANK DEPOSITORY BONDS.**

and to bind any of the Companies thereby as fully and to the same extent as if such bonds were signed by the President, sealed with the corporate seal of the applicable Company and duly attested by its Secretary, hereby ratifying and confirming all that the said Attorney(s)-in-Fact may do in the premises. Said appointment is made under and by authority of the following resolution adopted by the Board of Directors of each of the WESTFIELD INSURANCE COMPANY, WESTFIELD NATIONAL INSURANCE COMPANY and OHIO FARMERS INSURANCE COMPANY:

"Be It Resolved, that the President, any Senior Executive, any Secretary or any Fidelity & Surety Operations Executive or other Executive shall be and is hereby vested with full power and authority to appoint any one or more suitable persons as Attorney(s)-in-Fact to represent and act for and on behalf of the Company subject to the following provisions:

The Attorney-in-Fact may be given full power and authority for and in the name of and on behalf of the Company, to execute, acknowledge and deliver, any and all bonds, recognizances, contracts, agreements of indemnity and other conditional or obligatory undertakings and any and all notices and documents canceling or terminating the Company's liability thereunder, and any such instruments so executed by any such Attorney-in-Fact shall be as binding upon the Company as if signed by the President and sealed and attested by the Corporate Secretary."

"Be it Further Resolved, that the signature of any such designated person and the seal of the Company heretofore or hereafter affixed to any power of attorney or any certificate relating thereto by facsimile, and any power of attorney or certificate bearing facsimile signatures or facsimile seal shall be valid and binding upon the Company with respect to any bond or undertaking to which it is attached." (Each adopted at a meeting held on February 8, 2000).

In Witness Whereof, WESTFIELD INSURANCE COMPANY, WESTFIELD NATIONAL INSURANCE COMPANY and OHIO FARMERS INSURANCE COMPANY have caused these presents to be signed by their Senior Executive and their corporate seals to be hereto affixed this 25th day of AUGUST A.D., 2008 .

Corporate  
Seals  
Affixed



WESTFIELD INSURANCE COMPANY  
WESTFIELD NATIONAL INSURANCE COMPANY  
OHIO FARMERS INSURANCE COMPANY

*Richard L. Kinnaird, Jr.*

By:  
Richard L. Kinnaird, Jr., Senior Executive

State of Ohio  
County of Medina ss.:

On this 25th day of AUGUST A.D., 2008 , before me personally came Richard L. Kinnaird, Jr. to me known, who, being by me duly sworn, did depose and say, that he resides in Medina, Ohio; that he is Senior Executive of WESTFIELD INSURANCE COMPANY, WESTFIELD NATIONAL INSURANCE COMPANY and OHIO FARMERS INSURANCE COMPANY, the companies described in and which executed the above instrument; that he knows the seals of said Companies; that the seals affixed to said instrument are such corporate seals; that they were so affixed by order of the Boards of Directors of said Companies; and that he signed his name thereto by like order.

Notarial  
Seal  
Affixed



*William J. Kahelin*

William J. Kahelin, Attorney at Law, Notary Public  
My Commission Does Not Expire (Sec. 147.03 Ohio Revised Code)

State of Ohio  
County of Medina ss.:

I, Frank A. Carrino, Secretary of WESTFIELD INSURANCE COMPANY, WESTFIELD NATIONAL INSURANCE COMPANY and OHIO FARMERS INSURANCE COMPANY, do hereby certify that the above and foregoing is a true and correct copy of a Power of Attorney, executed by said Companies, which is still in full force and effect; and furthermore, the resolutions of the Boards of Directors, set out in the Power of Attorney are in full force and effect.

In Witness Whereof, I have hereunto set my hand and affixed the seals of said Companies at Westfield Center, Ohio, this 17th day of June A.D., 2009 .



*Frank A. Carrino*  
Frank A. Carrino, Secretary