



State of West Virginia  
 Department of Administration  
 Purchasing Division  
 2019 Washington Street East  
 Post Office Box 50130  
 Charleston, WV 25305-0130

# Request for Quotation

RFQ NUMBER  
**DEP14152**

PAGE  
**1**

ADDRESS CORRESPONDENCE TO ATTENTION OF  
**CHUCK BOWMAN**  
**304-558-2157**

VENDOR

**PRO CONTRACTING, INC.**  
**P.O. BOX 2442 / ARMORY RD**  
**CLARKSBURG, WV 26302**

SHIP TO

**ENVIRONMENTAL PROTECTION**  
**DEPT. OF**  
**OFFICE OF SPECIAL RECLAMATION**  
**105 S. RAILROAD STREET**  
**PHILIPPI, WV**  
**26416-9998 304-457-3219**

DATE PRINTED	TERMS OF SALE	SHIP VIA	F.O.B.	FREIGHT TERMS
01/26/2009				

BID OPENING DATE: **02/18/2009** BID OPENING TIME **01:30PM**

LINE	QUANTITY	UOP	CAT NO	ITEM NUMBER	UNIT PRICE	AMOUNT
<p>***** ADDENDUM NO. 1 *****</p> <p>ADDENDUM ISSUED FOR THE S. KELLY INDUSTRIES PROJECT TO DISTRIBUTE THE PRE-BID SIGN-IN SHEETS AND THE Q/A RESULTING FROM THE MANDATORY PRE-BID MEETING HELD 01/14/2009.</p> <p>BID OPENING DATE AND TIME HAVE BEEN EXTENDED TO 02/18/2009 AT 1:30 PM</p> <p>***** NO OTHER CHANGES *****</p>						
0001	1	JB		962-73		
RECLAMATION: WATER TREATMENT						566,365 <sup>00</sup>

RECEIVED

2009 FEB 18 A 10:08

PURCHASING DIVISION  
 STATE OF WV

SEE REVERSE SIDE FOR TERMS AND CONDITIONS

SIGNATURE <i>Chuck Bowman</i>	TELEPHONE 304-600-2400	DATE 2-17-09
TITLE President	FEIN 26-3348007	ADDRESS CHANGES TO BE NOTED ABOVE

WHEN RESPONDING TO RFQ, INSERT NAME AND ADDRESS IN SPACE ABOVE LABELED 'VENDOR'

**GENERAL TERMS & CONDITIONS**  
**REQUEST FOR QUOTATION (RFQ) AND REQUEST FOR PROPOSAL (RFP)**

1. Awards will be made in the best interest of the State of West Virginia.
2. The State may accept or reject in part, or in whole, any bid.
3. All quotations are governed by the *West Virginia Code* and the *Legislative Rules* of the Purchasing Division.
4. Prior to any award, the apparent successful vendor must be properly registered with the Purchasing Division and have paid the required \$125 fee.
5. All services performed or goods delivered under State Purchase Order/Contracts are to be continued for the term of the Purchase Order/Contracts, contingent upon funds being appropriated by the Legislature or otherwise being made available. In the event funds are not appropriated or otherwise available for these services or goods, this Purchase Order/Contract becomes void and of no effect after June 30.
6. Payment may only be made after the delivery and acceptance of goods or services.
7. Interest may be paid for late payment in accordance with the *West Virginia Code*.
8. Vendor preference will be granted upon written request in accordance with the *West Virginia Code*.
9. The State of West Virginia is exempt from federal and state taxes and will not pay or reimburse such taxes.
10. The Director of Purchasing may cancel any Purchase Order/Contract upon 30 days written notice to the seller.
11. The laws of the State of West Virginia and the *Legislative Rules* of the Purchasing Division shall govern all rights and duties under the Contract, including without limitation the validity of this Purchase Order/Contract.
12. Any reference to automatic renewal is hereby deleted. The Contract may be renewed only upon mutual written agreement of the parties.
13. **BANKRUPTCY:** In the event the vendor/contractor files for bankruptcy protection, this Contract may be deemed null and void, and terminated without further order.
14. **HIPAA BUSINESS ASSOCIATE ADDENDUM:** The West Virginia State Government HIPAA Business Associate Addendum (BAA), approved by the Attorney General, and available online at the Purchasing Division's web site (<http://www.state.wv.us/admin/purchase/vrc/hipaa.htm>) is hereby made part of the agreement. Provided that, the Agency meets the definition of a Cover Entity (45 CFR §160.103) and will be disclosing Protected Health Information (45 CFR §160.103) to the vendor.
15. **WEST VIRGINIA ALCOHOL & DRUG-FREE WORKPLACE ACT:** If this Contract constitutes a public improvement construction contract as set forth in Article 1D, Chapter 21 of the West Virginia Code ("The West Virginia Alcohol and Drug-Free Workplace Act"), then the following language shall hereby become part of this Contract: "The contractor and its subcontractors shall implement and maintain a written drug-free workplace policy in compliance with the West Virginia Alcohol and Drug-Free Workplace Act, as set forth in Article 1D, Chapter 21 of the West Virginia Code. The contractor and its subcontractors shall provide a sworn statement in writing, under the penalties of perjury, that they maintain a valid drug-free work place policy in compliance with the West Virginia and Drug-Free Workplace Act. It is understood and agreed that this Contract shall be cancelled by the awarding authority if the Contractor: 1) Fails to implement its drug-free workplace policy; 2) Fails to provide information regarding implementation of the contractor's drug-free workplace policy at the request of the public authority; or 3) Provides to the public authority false information regarding the contractor's drug-free workplace policy."

---

**INSTRUCTIONS TO BIDDERS**

1. Use the quotation forms provided by the Purchasing Division.
2. **SPECIFICATIONS:** Items offered must be in compliance with the specifications. Any deviation from the specifications must be clearly indicated by the bidder. Alternates offered by the bidder as **EQUAL** to the specifications must be clearly defined. A bidder offering an alternate should attach complete specifications and literature to the bid. The Purchasing Division may waive minor deviations to specifications.
3. Complete all sections of the quotation form.
4. Unit prices shall prevail in case of discrepancy.
5. All quotations are considered F.O.B. destination unless alternate shipping terms are clearly identified in the quotation.
6. **BID SUBMISSION:** All quotations must be delivered by the bidder to the office listed below prior to the date and time of the bid opening. Failure of the bidder to deliver the quotations on time will result in bid disqualifications: Department of Administration, Purchasing Division, 2019 Washington Street East, P.O. Box 50130, Charleston, WV 25305-0130



State of West Virginia  
 Department of Administration  
 Purchasing Division  
 2019 Washington Street East  
 Post Office Box 50130  
 Charleston, WV 25305-0130

# Request for Quotation

RFQ NUMBER  
 DEP14152

PAGE  
 1

ADDRESS CORRESPONDENCE TO ATTENTION OF  
 CHUCK BOWMAN  
 304-558-2157

VENDOR

PRO CONTRACTING, INC.  
 P.O. BOX 2442 / ARMORY RD  
 CLARKSBURG, WV 26302

SHIP TO

ENVIRONMENTAL PROTECTION  
 DEPT. OF  
 OFFICE OF SPECIAL RECLAMATION  
 105 S. RAILROAD STREET  
 PHILIPPI, WV  
 26416-9998 304-457-3219

DATE PRINTED	TERMS OF SALE	SHIP VIA	F.O.B.	FREIGHT TERMS
12/11/2008				

BID OPENING DATE: 02/10/2009 BID OPENING TIME 01:30PM

LINE	QUANTITY	UOP	CAT NO	ITEM NUMBER	UNIT PRICE	AMOUNT
0001	1	JB		962-73		566,365 <sup>00</sup>
RECLAMATION: WATER TREATMENT  THE WEST VIRGINIA PURCHASING DIVISION, FOR THE AGENCY, THE WEST VIRGINIA DEPARTMENT OF ENVIRONMENTAL PROTECTION, IS SOLICITING BIDS FROM QUALIFIED CONTRACTORS FOR A CONTRACT TO PROVIDE ALL LABOR AND MATERIALS TO PERFORM RECLAMATION ON THE MINING OPERATION OF S. KELLEY INDUSTRIES, NOW UNDER REVOKED PERMIT NUMBER(S) 51-78. THIS SITE CONSISTS OF APPROXIMATELY 10 ACRES AND IS LOCATED NEAR LITTLE FALLS, WV IN MONONGALIA COUNTY.  THE RECLAMATION SHALL BE PERFORMED UNDER THE GUIDANCE AND GENERAL SUPERVISION OF THE AGENT ASSIGNED TO THE PROJECT FOR THE STATE OF WEST VIRGINIA DEPARTMENT OF ENVIRONMENTAL PROTECTION.  A MANDATORY ON-SITE PREBID CONFERENCE SHALL BE HELD ON 01/14/2008 @ 10:00 AM. FAILURE TO ATTEND THE PREBI CONFERENCE WILL RESULT IN BID DISQUALIFICATION.  DIRECTIONS TO PREBID: IN MONONGALIA COUNTY, TURN SOUTH ON US ROUTE 119 AT I-68 INTERSECTION AND TRAVEL 5.3 MILES. TURN ONTO GUM SPRING ROAD (CR 119/11) AND TRAVEL 1.8 MILE. TURN LEFT ONTO ANOTHER ROCK BASED ROAD (CR 76/5) AND TRAVEL 1500 FEET TO THE SITE ON THE RIGHT.  ALL WORK MUST BE COMPLETED IN ACCORDANCE WITH THE PLANS AND SPECIFICATIONS PREPARED BY THE DEPARTMENT OF ENVIRONMENTAL PROTECTION AND PURCHASE ORDER ISSUED						

SEE REVERSE SIDE FOR TERMS AND CONDITIONS

SIGNATURE <i>A w R</i>	TELEPHONE 304-620-2400	DATE 2-18-09
TITLE President	FEIN 06-3348007	ADDRESS CHANGES TO BE NOTED ABOVE

WHEN RESPONDING TO RFQ, INSERT NAME AND ADDRESS IN SPACE ABOVE LABELED 'VENDOR'



State of West Virginia  
 Department of Administration  
 Purchasing Division  
 2019 Washington Street East  
 Post Office Box 50130  
 Charleston, WV 25305-0130

# Request for Quotation

RFQ NUMBER
DEP14152

PAGE
2

ADDRESS CORRESPONDENCE TO ATTENTION OF
CHUCK BOWMAN 304-558-2157

VENDOR

PRO CONTRACTING, INC.  
 P.O. BOX 2442 / ARMORY RD  
 CLARKSBURG, WV 26302

SHIP TO

ENVIRONMENTAL PROTECTION  
 DEPT. OF  
 OFFICE OF SPECIAL RECLAMATION  
 105 S. RAILROAD STREET  
 PHILIPPI, WV  
 26416-9998 304-457-3219

DATE PRINTED	TERMS OF SALE	SHIP VIA	F.O.B.	FREIGHT TERMS
12/11/2008				

BID OPENING DATE: 02/10/2009 BID OPENING TIME 01:30PM

LINE	QUANTITY	UOP	CAT NO	ITEM NUMBER	UNIT PRICE	AMOUNT
<p>BY THE DEPARTMENT OF ADMINISTRATION, DIVISION OF PURCHASING.</p> <p>EXHIBIT 5</p> <p>WEST VIRGINIA CODE 21-1D-5 PROVIDES THAT: ANY SOLICITATION FOR A PUBLIC IMPROVEMENT CONSTRUCTION CONTRACT REQUIRES EACH VENDOR THAT SUBMITS A BID FOR THE WORK TO SUBMIT AT THE SAME TIME AN AFFIDAVIT OF COMPLIANCE WITH THE BID. THE ENCLOSED PURCHASING AFFIDAVIT MUST BE SIGNED AND SUBMITTED WITH THE BID AS EVIDENCE OF THE VENDOR'S COMPLIANCE WITH THE PROVISIONS OF ARTICLE 1D, CHAPTER 21 OF THE WEST VIRGINIA CODE. FAILURE TO SUBMIT THE SIGNED PURCHASING AFFIDAVIT WITH THE BID SHALL RESULT IN DISQUALIFICATION OF SUCH BID.</p> <p>NOTICE TO PROCEED: THIS CONTRACT IS TO BE PERFORMED WITH 365 CALENDAR DAYS AFTER THE NOTICE TO PROCEED IS RECEIVED. UNLESS OTHERWISE SPECIFIED, THE FULLY EXECUTED PURCHASE ORDER WILL BE CONSIDERED NOTICE TO PROCEED.</p> <p>CANCELLATION: THE DIRECTOR OF PURCHASING RESERVES THE RIGHT TO CANCEL THIS CONTRACT IMMEDIATELY UPON WRITTEN NOTICE TO THE VENDOR IF THE MATERIALS OR WORKMANSHIP SUPPLIED ARE OF AN INFERIOR QUALITY OR DO NOT CONFORM WITH THE SPECIFICATIONS OF THE THE BID AND CONTRACT HERE IN.</p> <p>WAGE RATES: THE CONTRACTOR OR SUBCONTRACTOR SHALL PAY THE HIGHER OF THE U.S. DEPARTMENT OF LABOR MINIMUM WAGE RATES AS ESTABLISHED FOR MONONGALIA COUNTY, PURSUANT TO WEST VIRGINIA CODE 21-5A, ET, SEQ. (PREVAILING WAGE RATES APPLY TO THIS PROJECT)</p>						

SEE REVERSE SIDE FOR TERMS AND CONDITIONS

SIGNATURE <i>BWR</i>	TELEPHONE 304-620-2400	DATE 2-18-09
TITLE President	FEIN 06-3348207	ADDRESS CHANGES TO BE NOTED ABOVE

WHEN RESPONDING TO RFQ, INSERT NAME AND ADDRESS IN SPACE ABOVE LABELED 'VENDOR'



State of West Virginia  
 Department of Administration  
 Purchasing Division  
 2019 Washington Street East  
 Post Office Box 50130  
 Charleston, WV 25305-0130

# Request for Quotation

RFQ NUMBER
DEP14152

PAGE
3

ADDRESS CORRESPONDENCE TO ATTENTION OF
CHUCK BOWMAN 304-558-2157

VENDOR

PRO CONTRACTING, INC.  
 P.O. BOX 2442 / ARMORY RD  
 CLARKSBURG, WV 26302

SHIP TO

ENVIRONMENTAL PROTECTION  
 DEPT. OF  
 OFFICE OF SPECIAL RECLAMATION  
 105 S. RAILROAD STREET  
 PHILIPPI, WV  
 26416-9998 304-457-3219

DATE PRINTED	TERMS OF SALE	SHIP VIA	F.O.B.	FREIGHT TERMS
12/11/2008				

BID OPENING DATE: 02/10/2009 BID OPENING TIME 01:30PM

LINE	QUANTITY	UOP	CAT NO	ITEM NUMBER	UNIT PRICE	AMOUNT
<p>ARBITRATION: ANY REFERENCES MADE TO ARBITRATION OR INTEREST FOR PAYMENTS DUE (EXCEPT FOR ANY INTEREST REQUIRED BY STATE LAW) CONTAINED IN THIS CONTRACT OR IN ANY AMERICAN INSTITUTE OF ARCHITECTS DOCUMENTS PERTAINING TO THIS CONTRACT ARE HEREBY DELETED.</p> <p>WORKERS' COMPENSATION: VENDOR IS REQUIRED TO PROVIDE A CERTIFICATE FROM WORKERS' COMPENSATION IF SUCCESSFUL.</p> <p>ALL OF THE ITEMS CHECKED BELOW WILL BE A REQUIREMENT OF THIS CONTRACT:</p> <p>(XX) INSURANCE: SUCCESSFUL VENDOR SHALL FURNISH PROOF OF COMMERCIAL GENERAL LIABILITY INSURANCE PRIOR TO ISSUANCE OF CONTRACT. UNLESS OTHERWISE SPECIFIED IN THE BID DOCUMENTS, THE MINIMUM AMOUNT OF INSURANCE COVERAGE REQUIRED IS \$250,000.</p> <p>( ) BUILDERS RISK INSURANCE: SUCCESSFUL VENDOR SHALL FURNISH PROOF OF BUILDERS RISK - ALL RISK INSURANCE IN AN AMOUNT EQUAL TO 100% OF THE AMOUNT OF THE CONTRACT.</p> <p>(XX) BONDS: FIVE PERCENT (5%) OF THE TOTAL AMOUNT OF THE BID PAYABLE TO THE STATE OF WEST VIRGINIA, SHALL BE SUBMITTED WITH EACH BID AS A BID BOND. THE SUCCESSFUL BIDDER SHALL ALSO FURNISH A PERFORMANCE BOND AND LABOR/MATERIAL BOND FOR 100% OF THE AMOUNT OF THE CONTRACT. BONDS MAY BE PROVIDED IN THE FORM OF A CERTIFIED CHECK, IRREVOCABLE LETTER OF CREDIT, OR BOND FURNISHED BY A SOLVENT SURETY COMPANY AUTHORIZED TO DO BUSINESS IN THE STATE OF WEST VIRGINIA. A LETTER OF CREDIT SUBMITTED IN LIEU OF A BOND WILL ONLY BE ALLOWED FOR PROJECTS UNDER \$100,000. PERSONAL OR BUSINESS CHECKS ARE NOT ACCEPTABLE IN LIEU OF THE 5% BID BOND, PERFORMANCE BOND, OR LABOR AND MATERIAL BOND.</p>						

SEE REVERSE SIDE FOR TERMS AND CONDITIONS

SIGNATURE	<i>John W. R...</i>	TELEPHONE	304 622-2400	DATE	2/18/09
TITLE	PRESIDENT	FEIN	26-3348227	ADDRESS CHANGES TO BE NOTED ABOVE	

WHEN RESPONDING TO RFQ, INSERT NAME AND ADDRESS IN SPACE ABOVE LABELED 'VENDOR'



State of West Virginia  
 Department of Administration  
 Purchasing Division  
 2019 Washington Street East  
 Post Office Box 50130  
 Charleston, WV 25305-0130

# Request for Quotation

RFQ NUMBER
DEP14152

PAGE
4

ADDRESS CORRESPONDENCE TO ATTENTION OF
CHUCK BOWMAN 304-558-2157

VENDOR

PRO CONTRACTING, INC.  
 P.O. BOX 2442 / ARMORY RD  
 CLARKSBURG, WV 26302

SHIP TO

ENVIRONMENTAL PROTECTION  
 DEPT. OF  
 OFFICE OF SPECIAL RECLAMATION  
 105 S. RAILROAD STREET  
 PHILIPPI, WV  
 26416-9998 304-457-3219

DATE PRINTED	TERMS OF SALE	SHIP VIA	FOB	FREIGHT TERMS
12/11/2008				

BID OPENING DATE: 02/10/2009	BID OPENING TIME 01:30PM
------------------------------	--------------------------

LINE	QUANTITY	UOP	CAT NO	ITEM NUMBER	UNIT PRICE	AMOUNT
<p>( ) MAINTENANCE BOND: A TWO (2) YEAR MAINTENANCE BOND COVERING THE ROOFING SYSTEM WILL BE A REQUIREMENT OF THE SUCCESSFUL VENDOR.</p> <p>REV. 11/00</p> <p>CONTRACTORS LICENSE</p> <p>WEST VIRGINIA STATE CODE 21-11-2 REQUIRES THAT ALL PERSONS DESIRING TO PERFORM CONTRACTING WORK IN THIS STATE MUST BE LICENSED. THE WEST VIRGINIA CONTRACTORS LICENSING BOARD IS EMPOWERED TO ISSUE THE CONTRACTORS LICENSE. APPLICATIONS FOR A CONTRACTORS LICENSE MAY BE MADE BY CONTACTING THE WEST VIRGINIA DIVISION OF LABOR CAPITOL COMPLEX, BUILDING 3, ROOM 319, CHARLESTON, WV 25305. TELEPHONE: (304) 558-7890.</p> <p>WEST VIRGINIA STATE CODE 21-11-11 REQUIRES ANY PROSPECTIVE BIDDER TO INCLUDE THE CONTRACTORS LICENSE NUMBER ON THEIR BID.</p> <p>BIDDER TO COMPLETE:          CONTRACTORS NAME: ..... <i>Pro Contracting, Inc...</i>          CONTRACTORS LICENSE NO.: <i>WV# 044670</i>.....</p> <p>THE SUCCESSFUL BIDDER WILL BE REQUIRED TO FURNISH A COPY OF THEIR CONTRACTORS LICENSE PRIOR TO ISSUANCE OF A PURCHASE ORDER/CONTRACT.</p> <p>APPLICABLE LAW</p> <p>THE WEST VIRGINIA STATE CODE, PURCHASING DIVISION RULES AND REGULATIONS, AND THE INFORMATION PROVIDED IN THE "REQUEST FOR QUOTATION" ISSUED BY THE PURCHASING</p>						

SEE REVERSE SIDE FOR TERMS AND CONDITIONS			
SIGNATURE <i>D. W. H.</i>	TELEPHONE <i>304-600-2400</i>	DATE <i>2-18-09</i>	
TITLE <i>President</i>	FEIN <i>06-3348007</i>	ADDRESS CHANGES TO BE NOTED ABOVE	

WHEN RESPONDING TO RFQ, INSERT NAME AND ADDRESS IN SPACE ABOVE LABELED 'VENDOR'



State of West Virginia  
 Department of Administration  
 Purchasing Division  
 2019 Washington Street East  
 Post Office Box 50130  
 Charleston, WV 25305-0130

# Request for Quotation

RFQ NUMBER
DEP14152

PAGE
5

ADDRESS CORRESPONDENCE TO ATTENTION OF
CHUCK BOWMAN 304-558-2157

VENDOR

PRO CONTRACTING, INC.  
 P.O. BOX 2442 / ARMORY RD  
 CLARKSBURG, WV 26302

SHIP TO

ENVIRONMENTAL PROTECTION  
 DEPT. OF  
 OFFICE OF SPECIAL RECLAMATION  
 105 S. RAILROAD STREET  
 PHILIPPI, WV  
 26416-9998 304-457-3219

DATE PRINTED	TERMS OF SALE	SHIP VIA	F.O.B.	FREIGHT TERMS
12/11/2008				

BID OPENING DATE: 02/10/2009 BID OPENING TIME 01:30PM

LINE	QUANTITY	UOP	CAT. NO.	ITEM NUMBER	UNIT PRICE	AMOUNT
<p>DIVISION IS THE SOLE AUTHORITY GOVERNING THIS PROCUREMENT.</p> <p>ANY INFORMATION PROVIDED IN SPECIFICATION MANUALS, OR ANY OTHER SOURCE, VERBAL OR WRITTEN, WHICH CONTRADICTS OR ALTERS THE INFORMATION PROVIDED FROM THE SOURCES AS DESCRIBED IN THE ABOVE PARAGRAPH IS VOID AND OF NO EFFECT.</p> <p>BANKRUPTCY: IN THE EVENT THE VENDOR/CONTRACTOR FILES FOR BANKRUPTCY PROTECTION, THIS CONTRACT IS AUTOMATICALLY NULL AND VOID, AND IS TERMINATED WITHOUT FURTHER ORDER.</p> <p>PREFERENCE FOR USE OF DOMESTIC STEEL PRODUCTS</p> <p>L. EXCEPT WHEN AUTHORIZED BY THE DIRECTOR OF THE PURCHASING DIVISION PURSUANT TO SUBSECTION 2 BELOW NO CONTRACTOR MAY USE OR SUPPLY STEEL PRODUCTS FOR A STATE CONTRACT PROJECT OTHER THAN THOSE STEEL PRODUCTS MADE IN THE UNITED STATES. AS USED USED IN THIS CONTRACT,</p> <p>A. "STATE CONTRACT PROJECT" MEANS ANY ERECTION OR CONSTRUCTION OF, OR ANY ADDITION TO, ALTERATION OF OR OTHER IMPROVEMENT TO ANY BUILDING OR STRUCTURE, INCLUDING, BUT NOT LIMITED TO, ROADS OR HIGHWAYS, OR THE INSTALLATION OF ANY HEATING OR COOLING OR VENTILATING PLANTS OR OTHER EQUIPMENT, OR THE SUPPLY OF AND MATERIALS FOR SUCH PROJECTS, PURSUANT TO A CONTRACT WITH THE STATE OF WEST VIRGINIA FOR WHICH BIDS WERE SOLICITED ON OR AFTER JUNE 6, 2001.</p> <p>B. "STEEL PRODUCTS" MEANS PRODUCTS ROLLED, FORMED, SHAPED, DRAWN, EXTRUDED, FORGED, CAST,</p>						

SEE REVERSE SIDE FOR TERMS AND CONDITIONS

SIGNATURE	<i>De W L</i>	TELEPHONE	304-622-2400	DATE	2-18-09
TITLE	President	FEIN	06-3348207	ADDRESS CHANGES TO BE NOTED ABOVE	

WHEN RESPONDING TO RFQ, INSERT NAME AND ADDRESS IN SPACE ABOVE LABELED 'VENDOR'



State of West Virginia  
 Department of Administration  
 Purchasing Division  
 2019 Washington Street East  
 Post Office Box 50130  
 Charleston, WV 25305-0130

# Request for Quotation

RFO NUMBER
DEP14152

PAGE
6

ADDRESS CORRESPONDENCE TO ATTENTION OF:
CHUCK BOWMAN 304-558-2157

VENDOR

PRO CONTRACTING, INC.  
 P.O. BOX 2442 / ARMORY RD  
 CLARKSBURG, WV 26302

SHIP TO

ENVIRONMENTAL PROTECTION  
 DEPT. OF  
 OFFICE OF SPECIAL RECLAMATION  
 105 S. RAILROAD STREET  
 PHILIPPI, WV  
 26416-9998 304-457-3219

DATE PRINTED	TERMS OF SALE	SHIP VIA	FOB	FREIGHT TERMS
12/11/2008				

BID OPENING DATE: 02/10/2009 BID OPENING TIME 01:30PM

LINE	QUANTITY	UOP	CAT NO.	ITEM NUMBER	UNIT PRICE	AMOUNT
				<p>FABRICATED OR OTHERWISE SIMILARLY PROCESSED, OR PROCESSED BY A COMBINATION OF TWO OR MORE OF SUCH OPERATIONS, FROM STEEL MADE BY THE OPEN HEARTH, BASIC OXYGEN, ELECTRIC FURNACE, BESSEMER OR OTHER STEEL MAKING PROCESS.</p> <p>C. "UNITED STATES" MEANS THE UNITED STATES OF AMERICA AND INCLUDES ALL TERRITORY, CONTINENTAL OR INSULAR, SUBJECT TO THE JURISDICTION OF THE UNITED STATES.</p> <p>2. THE DIRECTOR OF THE PURCHASING DIVISION MAY, IN WRITING, AUTHORIZE THE USE OF FOREIGN STEEL PRODUCTS IF:</p> <p>A. THE COST FOR EACH CONTRACT ITEM USED DOES NOT EXCEED ONE TENTH OF ONE PERCENT (.1%) OF THE TOTAL CONTRACT COST OR TWO THOUSAND FIVE HUNDRED DOLLARS (2,500.00), WHICHEVER IS GREATER. FOR THE PURPOSES OF THIS SECTION, THE COST IS THE VALUE OF THE STEEL PRODUCT AS DELIVERED TO THE PROJECT OR</p> <p>B. THE DIRECTOR OF THE PURCHASING DIVISION DETERMINES THAT SPECIFIED STEEL MATERIALS ARE NOT PRODUCED IN THE UNITED STATES IN SUFFICIENT QUANTITY OR OTHERWISE ARE NOT REASONABLY AVAILABLE TO MEET CONTRACT REQUIREMENTS.</p> <p>3. A CONTRACTOR WHO USES STEEL PRODUCTS IN VIOLATION OF THIS SECTION MAY BE SUBJECT TO CIVIL PENALTIES PURSUANT TO WV CODE SECTION 5A-3-56.</p>		

REV. 10/01/01

SEE REVERSE SIDE FOR TERMS AND CONDITIONS

SIGNATURE	<i>Chuck Bowman</i>	TELEPHONE	304-620-2400	DATE	0-18-09
TITLE	President	FEIN	26-3348227	ADDRESS CHANGES TO BE NOTED ABOVE	

WHEN RESPONDING TO RFQ, INSERT NAME AND ADDRESS IN SPACE ABOVE LABELED 'VENDOR'





State of West Virginia  
 Department of Administration  
 Purchasing Division  
 2019 Washington Street East  
 Post Office Box 50130  
 Charleston, WV 25305-0130

# Request for Quotation

RFQ NUMBER
DEP14152

PAGE
7

ADDRESS CORRESPONDENCE TO ATTENTION OF
CHUCK BOWMAN 304-558-2157

VENDOR

PRO CONTRACTING, INC.  
 P.O. BOX 2442 / ARMORY RD  
 CLARKSBURG, WV 26302

SHIP TO

ENVIRONMENTAL PROTECTION  
 DEPT. OF  
 OFFICE OF SPECIAL RECLAMATION  
 105 S. RAILROAD STREET  
 PHILIPPI, WV  
 26416-9998 304-457-3219

DATE PRINTED	TERMS OF SALE	SHIP VIA	F.O.B.	FREIGHT TERMS
12/11/2008				

BID OPENING DATE: 02/10/2009 BID OPENING TIME 01:30PM

LINE	QUANTITY	UOP	CAT. NO.	ITEM NUMBER	UNIT PRICE	AMOUNT
EXHIBIT 7						
DOMESTIC ALUMINUM, GLASS & STEEL IN PUBLIC WORKS PROJECTS						
IN ACCORDANCE WITH WEST VIRGINIA CODE 5-19-1 ET., SEQ., EVERY CONTRACT FOR CONSTRUCTION, RECONSTRUCTION, ALTERATION, REPAIR, IMPROVEMENT OR MAINTENANCE OF PUBLIC WORKS, WHERE THE COST IS MORE THAN \$50,000 AND, IN THE CASE OF STEEL ONLY, WHERE THE COST OF STEEL IS MORE THAN \$50,000 OR WHERE MORE THAN 10,000 POUNDS OF STEEL ARE REQUIRED, THE STATE WILL ACCEPT ONLY ALUMINUM GLASS, OR STEEL PRODUCTS PRODUCED IN THE UNITED STATES. IN ADDITION, ITEMS OF MACHINERY OR EQUIPMENT PURCHASED FOR USE AT THE SITE OF PUBLIC WORKS SHALL BE MADE OF DOMESTIC ALUMINUM, GLASS OR STEEL, UNLESS THE COST OF THE PRODUCT IS LESS THAN \$50,000 OR LESS THAN 10,000 POUNDS OF STEEL ARE USED IN PUBLIC WORKS PROJECTS.						
FOREIGN MADE ALUMINUM, GLASS OR STEEL PRODUCTS MAY BE ACCEPTED ONLY IF THE COST OF DOMESTIC PRODUCTS IS FOUND TO BE UNREASONABLE. SUCH COST IS UNREASONABLE IF IT IS 20% OR MORE HIGHER THAN THE BID PRICE FOR FOREIGN MADE PRODUCTS. IF THE DOMESTIC ALUMINUM, GLASS OR STEEL PRODUCTS TO BE SUPPLIED OR PRODUCED IN A "SUBSTANTIAL LABOR SURPLUS AREA", AS DEFINED BY THE UNITED STATES DEPARTMENT OF LABOR, FOREIGN PRODUCTS MAY BE SUPPLIED ONLY IF DOMESTIC PRODUCTS ARE 30% OR MORE HIGHER IN PRICE THAN THE FOREIGN MADE PRODUCTS.						
IF, PRIOR TO THE AWARD OF A CONTRACT UNDER THE ABOVE PROVISIONS, THE SPENDING OFFICER OF THE SPENDING UNIT DETERMINES THAT THERE EXISTS A BID FOR LIKE FOREIGN ALUMINUM, GLASS OR STEEL THAT IS REASONABLE AND LOWER THAN THE LOWEST BID DOMESTIC PRODUCTS, THE SPENDING OFFICE MAY REQUEST, IN WRITING, A REEVALUATION AND						

SEE REVERSE SIDE FOR TERMS AND CONDITIONS

SIGNATURE	<i>Chuck Bowman</i>	TELEPHONE	304-622-2400	DATE	2-18-09
TITLE	President	FEIN	06-3348007	ADDRESS CHANGES TO BE NOTED ABOVE	

WHEN RESPONDING TO RFQ, INSERT NAME AND ADDRESS IN SPACE ABOVE LABELED 'VENDOR'



State of West Virginia  
 Department of Administration  
 Purchasing Division  
 2019 Washington Street East  
 Post Office Box 50130  
 Charleston, WV 25305-0130

# Request for Quotation

RFQ NUMBER
DEP14152

PAGE
8

ADDRESS CORRESPONDENCE TO ATTENTION OF
CHUCK BOWMAN 304-558-2157

PROPERTY

PRO CONTRACTING, INC.  
 P.O. BOX 2442 / ARMORY RD  
 CLARKSBURG, WV 26302

SHIP TO

ENVIRONMENTAL PROTECTION  
 DEPT. OF  
 OFFICE OF SPECIAL RECLAMATION  
 105 S. RAILROAD STREET  
 PHILIPPI, WV  
 26416-9998 304-457-3219

DATE PRINTED	TERMS OF SALE	SHIP VIA	F.O.B.	FREIGHT TERMS
12/11/2008				

BID OPENING DATE: 02/10/2009 BID OPENING TIME 01:30PM

LINE	QUANTITY	UOP	CAT NO	ITEM NUMBER	UNIT PRICE	AMOUNT
<p>REDUCTION IN THE LOWEST BID FOR SUCH DOMESTIC PRODUCTS. ALL VENDORS MUST INDICATE IN THEIR BID IF THEY ARE SUPPLYING FOREIGN ALUMINUM, GLASS OR STEEL.</p> <p>REV. 3/88</p> <p>EXHIBIT 9</p> <p>NOTICE FOR ISSUANCE &amp; ACKNOWLEDGEMENT OF CONSTRUCTION PROJECT ADDENDA</p> <p>THE ARCHITECT/ENGINEER AND/OR AGENCY SHALL BE REQUIRED TO ABIDE BY THE FOLLOWING SCHEDULE IN ISSUING CONSTRUCTION PROJECT ADDENDA FOR STATE AGENCIES:</p> <p>(1) THE ARCHITECT/ENGINEER SHALL PREPARE THE ADDENDUM AND A LIST OF ALL PARTIES THAT HAVE PROCURED DRAWINGS AND SPECIFICATIONS FOR THE PROJECT. THE ADDENDUM AND LIST SHALL BE FORWARDED TO THE BUYER IN THE STATE PURCHASING DIVISION. THE ARCHITECT/ENGINEER SHALL ALSO SEND A COPY OF THE ADDENDUM TO THE STATE AGENCY FOR WHICH THE CONTRACT IS ISSUED.</p> <p>(2) THE BUYER SHALL SEND THE ADDENDUM TO ALL INTERESTED PARTIES AND, IF NECESSARY, EXTEND THE BID OPENING DATE. ANY ADDENDUM SHOULD BE RECEIVED BY THE BUYER WITHIN FOURTEEN (14) DAYS PRIOR TO THE BID OPENING DATE.</p> <p>(3) ALL ADDENDA SHOULD BE FORMALLY ACKNOWLEDGED BY ALL BIDDERS AND SUBMITTED TO THE STATE PURCHASING DIVISION. THE SAME RULES AND REGULATIONS THAT APPLY TO THE ORIGINAL BIDDING DOCUMENT SHALL ALSO APPLY TO AN ADDENDUM DOCUMENT. THE ONLY EXCEPTION MAY BE FOR AN ADDENDUM THAT IS ISSUED FOR THE SOLE PURPOSE OF CHANGING A BID OPENING TIME AND/OR</p>						

SEE REVERSE SIDE FOR TERMS AND CONDITIONS

SIGNATURE	TELEPHONE	DATE
<i>Bowman</i>	304-622-2400	2-18-09
TITLE	FEIN	ADDRESS CHANGES TO BE NOTED ABOVE
President	06-3348007	

WHEN RESPONDING TO RFQ, INSERT NAME AND ADDRESS IN SPACE ABOVE LABELED 'VENDOR'



State of West Virginia  
 Department of Administration  
 Purchasing Division  
 2019 Washington Street East  
 Post Office Box 50130  
 Charleston, WV 25305-0130

# Request for Quotation

RFQ NUMBER  
 DEP14152

PAGE  
 9

ADDRESS CORRESPONDENCE TO ATTENTION OF  
 CHUCK BOWMAN  
 304-558-2157

VENDOR

PRO CONTRACTING, INC.  
 P.O. BOX 2442 / ARMORY RD  
 CLARKSBURG, WV 26302

SHIP TO

ENVIRONMENTAL PROTECTION  
 DEPT. OF  
 OFFICE OF SPECIAL RECLAMATION  
 105 S. RAILROAD STREET  
 PHILIPPI, WV  
 26416-9998 304-457-3219

DATE PRINTED	TERMS OF SALE	SHIP VIA	F.O.B.	FREIGHT TERMS
12/11/2008				

BID OPENING DATE: 02/10/2009 BID OPENING TIME 01:30PM

LINE	QUANTITY	UOP	CAT. NO.	ITEM NUMBER	UNIT PRICE	AMOUNT
------	----------	-----	----------	-------------	------------	--------

DATE. REV. 11/96 EXHIBIT 10 ADDENDUM ACKNOWLEDGEMENT I HEREBY ACKNOWLEDGE RECEIPT OF THE FOLLOWING CHECKED ADDENDUM(S) AND HAVE MADE THE NECESSARY REVISIONS TO MY PROPOSAL, PLANS AND/OR SPECIFICATION, ETC. ADDENDUM NOS.: NO. 1     ✓     1-26-09 NO. 2     ..... NO. 3     ..... NO. 4     ..... NO. 5     ..... I UNDERSTAND THAT FAILURE TO CONFIRM THE RECEIPT OF THE ADDENDUM(S) MAY BE CAUSE FOR REJECTION OF THE BIDS. VENDOR MUST CLEARLY UNDERSTAND THAT ANY VERBAL REPRESENTATION MADE OR ASSUMED TO BE MADE DURING ANY ORAL DISCUSSION HELD BETWEEN VENDOR'S REPRESENTATIVES AND ANY STATE PERSONNEL IS NOT BINDING. ONLY THE INFORMATION ISSUED IN WRITING AND ADDED TO THE SPECIFICATIONS BY AN OFFICIAL ADDENDUM IS BINDING.						
---	--	--	--	--	--	--

SEE REVERSE SIDE FOR TERMS AND CONDITIONS

SIGNATURE *Chuck Bowman* TELEPHONE 304-622-0400 DATE 0-18-09

TITLE *President* FEIN 06-3348007 ADDRESS CHANGES TO BE NOTED ABOVE

WHEN RESPONDING TO RFQ, INSERT NAME AND ADDRESS IN SPACE ABOVE LABELED 'VENDOR'



State of West Virginia  
 Department of Administration  
 Purchasing Division  
 2019 Washington Street East  
 Post Office Box 50130  
 Charleston, WV 25305-0130

# Request for Quotation

RFQ NUMBER  
 DEP14152

PAGE  
 10

ADDRESS CORRESPONDENCE TO ATTENTION OF  
 CHUCK BOWMAN  
 304-558-2157

VENDOR

PRO CONTRACTING, INC.  
 P.O. BOX 2442 / ARMORY RD  
 CLARKSBURG, WV 26302

SHIP TO

ENVIRONMENTAL PROTECTION  
 DEPT. OF  
 OFFICE OF SPECIAL RECLAMATION  
 105 S. RAILROAD STREET  
 PHILIPPI, WV  
 26416-9998 304-457-3219

DATE PRINTED	TERMS OF SALE	SHIP VIA	F.O.B.	FREIGHT TERMS
12/11/2008				

BID OPENING DATE: 02/10/2009 BID OPENING TIME 01:30PM

LINE	QUANTITY	UOP	CAT NO	ITEM NUMBER	UNIT PRICE	AMOUNT
<p>.....SIGNATURE</p> <p>.....COMPANY</p> <p>.....DATE</p> <p>REV. 11/96</p> <p>NOTICE</p> <p>A SIGNED BID MUST BE SUBMITTED TO:</p> <p>DEPARTMENT OF ADMINISTRATION            PURCHASING DIVISION            BUILDING 15            2019 WASHINGTON STREET, EAST            CHARLESTON, WV 25305-0130</p> <p>THE BID SHOULD CONTAIN THIS INFORMATION ON THE FACE OF THE ENVELOPE OR THE BID MAY NOT BE CONSIDERED:</p> <p>SEALED BID</p> <p>BUYER: CB-23</p> <p>REQ. NO.: DEP14152</p> <p>BID OPENING DATE: 02/10/2009</p> <p>BID OPENING TIME: 1:30 P.M.</p> <p>PLEASE PROVIDE A FAX NUMBER IN CASE IT IS NECESSARY TO CONTACT YOU REGARDING YOUR BID:</p>						

SEE REVERSE SIDE FOR TERMS AND CONDITIONS

SIGNATURE <i>B. W. P.</i>	TELEPHONE 304-622-2400	DATE 2-18-09
TITLE <i>President</i>	FEIN 06-3348227	ADDRESS CHANGES TO BE NOTED ABOVE

WHEN RESPONDING TO RFQ, INSERT NAME AND ADDRESS IN SPACE ABOVE LABELED 'VENDOR'



State of West Virginia  
 Department of Administration  
 Purchasing Division  
 2019 Washington Street East  
 Post Office Box 50130  
 Charleston, WV 25305-0130

# Request for Quotation

RFQ NUMBER
DEP14152

PAGE
11

ADDRESS CORRESPONDENCE TO ATTENTION OF
CHUCK BOWMAN 304-558-2157

PROBID

PRO CONTRACTING, INC.  
 P.O. BOX 2442 / ARMORY RD  
 CLARKSBURG, WV 26302

SHIP TO

ENVIRONMENTAL PROTECTION  
 DEPT. OF  
 OFFICE OF SPECIAL RECLAMATION  
 105 S. RAILROAD STREET  
 PHILIPPI, WV  
 26416-9998 304-457-3219

DATE PRINTED	TERMS OF SALE	SHIP VIA	F.O.B.	FREIGHT TERMS
12/11/2008				

BID OPENING DATE: 02/10/2009 BID OPENING TIME 01:30PM

LINE	QUANTITY	UOP	CAT NO	ITEM NUMBER	UNIT PRICE	AMOUNT
------	----------	-----	--------	-------------	------------	--------

304 600-0410

PLEASE PRINT OR TYPE NAME OF PERSON TO CONTACT CONCERNING THIS QUOTE:

Steve Szabo

\*\*\*\*\* THIS IS THE END OF RFQ DEP14152 \*\*\*\*\* TOTAL: 566,365<sup>00</sup>

SEE REVERSE SIDE FOR TERMS AND CONDITIONS

SIGNATURE <i>John W. ...</i>	TELEPHONE 304-600-2400	DATE 2-18-09
TITLE President	FEIN 06-3348207	ADDRESS CHANGES TO BE NOTED ABOVE

WHEN RESPONDING TO RFQ, INSERT NAME AND ADDRESS IN SPACE ABOVE LABELED 'VENDOR'

SITE LOCATION

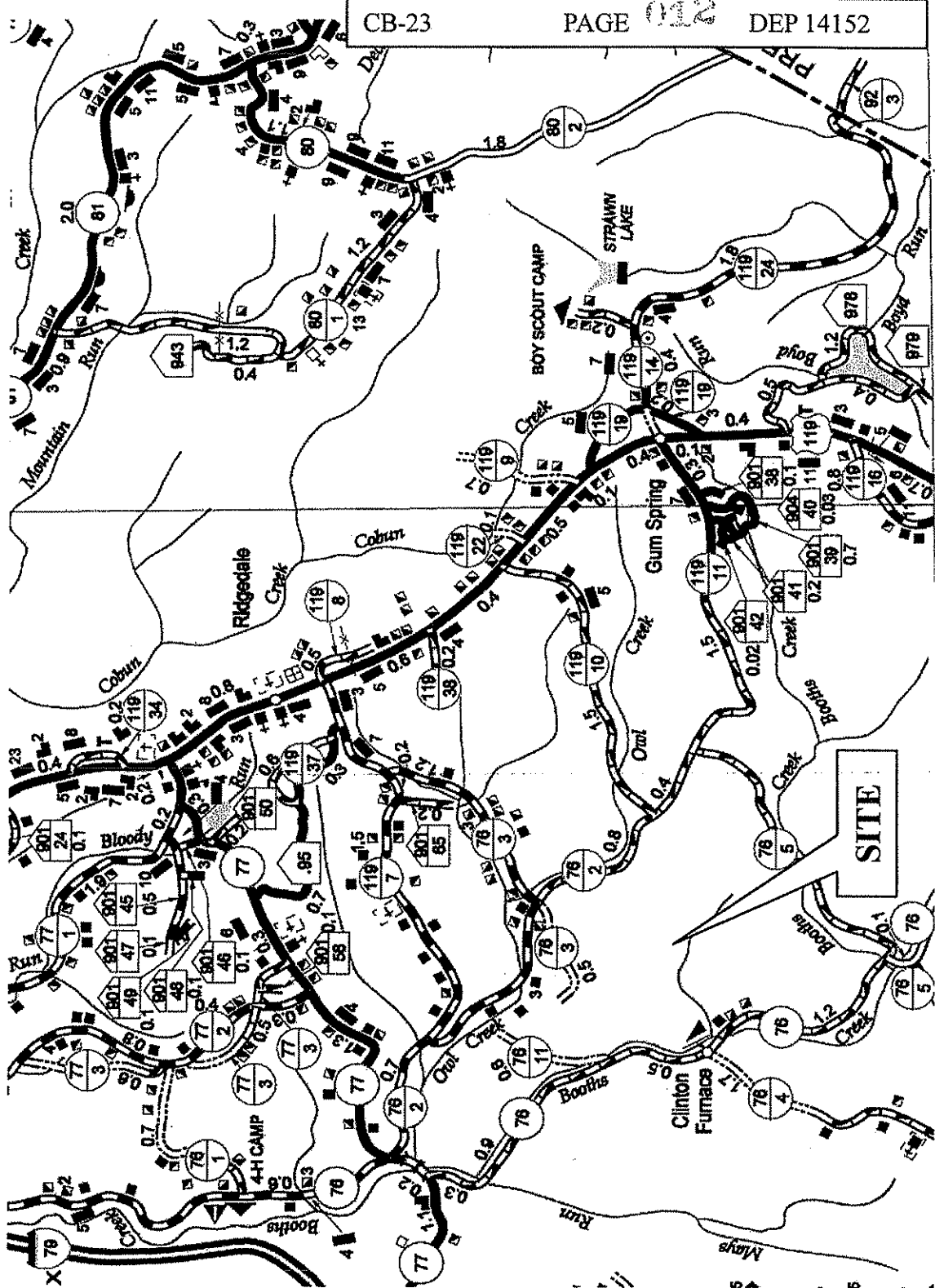

In Monongalia County, turn South on US Route 119 at I-68 intersection, and travel 5.3 miles. Turn onto Gum Spring Road (CR 119/11) and travel 1.8 miles. Turn left onto another rock based road (CR 76/5) and travel 1500 feet to the site on the right.

WV-36a STATE OF WEST VIRGINIA  
REV. 5-1-08 PURCHASING CONTINUATION SHEET  
VENDOR:

### SCOPE OF WORK

The successful bidder shall provide appropriate equipment, materials, labor and any technical services needed for the successful reclamation of S. KELLY INDUSTRIES, Permit 51-78, and any disturbance associated with such operation. The General Performance Standards (GPS) shall apply to all items in Scope of Work.

Work necessary on this site will include the following items, but is not limited to these:

1. Upon mobilization to the site, which will be directed in a written Notice to Proceed, the access roads shall be developed in accordance with bid item #4. If, fuel and lubricants are to be stored on site, bid item #2 shall be in place before fuel is delivered. The project sign is to be obtained and installed.
2. Storm water management in the form as described in bid item #8 shall be installed (described locations).
3. Revegetation and soil improvements are required for all disturbed areas. Reclamation is to be according to the attached specifications, plans, and clarifying discussions at the Pre-Bid Conference.
4. Construct new access road.
5. Install culverts.
6. Construct grouted riprap channels.
7. Construct seep conveyance drains (5).
8. Eliminate pond and wetland.
9. Modify existing wetlands (2).
10. Install a dosing unit and twenty ton silo for calcium oxide treatment of the seep water.
11. Construct sludge disposal cells (2).
12. Vegetative enhancement with seed, lime, fertilizer, and mulch.
13. Any other site specific items required.

I, David B. McCoy, the undersigned, hereby certify <sup>1</sup> that this Reclamation Plan is correct and shows to the best of my knowledge and belief all the information required by the surface mining laws of the State of West Virginia. The source of information was the approved mining and reclamation plan contained in the forfeited surface mine permit, existing site conditions and information contained in the WV DEP, Inspection and Enforcement files.

*David B. McCoy*

Registered Professional Engineer WV No. 14375

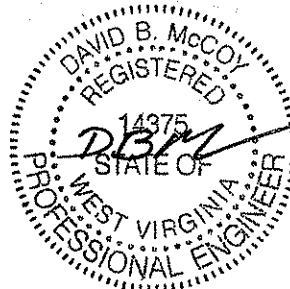

Date: 10-27-08

<sup>1</sup> The term "certify" as used herein is defined as follows: An engineer's certification of conditions is a declaration of professional judgment. It does not constitute a warranty or guarantee, either expressed or implied.

PRO CONTRACTING, INC.  
 PO BOX 2442  
 CLARKSBURG, WV 26302

BUYER CB-23	PAGE 014	REQ. OR PO NO. DEP 14152
SPENDING UNIT WEST VIRGINIA DEPARTMENT OF ENVIRONMENTAL PROTECTION/SPECIAL RECLAMATION		

WV-36a STATE OF WEST VIRGINIA  
 REV. 5-1-08 PURCHASING CONTINUATION SHEET  
 VENDOR:

ITEM NO.	QUANTITY	DESCRIPTION	UNIT PRICE	AMOUNT
<b>BID SCHEDULE</b>				
PERMIT NAME: <u>S. KELLY INDUSTRIES</u> PERMIT NUMBER(S): <u>51-78</u>				
The DEP reserves the right to request additional information and supporting documentation regarding unit prices when the unit price appears to be unreasonable.				
1.0	LUMP SUM	<u>MOBILIZATION/DEMobilIZATION/PROJECT SIGN</u> (5% Total Bid Maximum for this permit)	LUMP SUM	\$ <u>26,148<sup>00</sup></u>
2.0	LUMP SUM	<u>SPILL CONTAINMENT AREA (S.C.A.)</u> (\$1,000.00 Maximum Bid for this permit)	LUMP SUM	\$ <u>750<sup>00</sup></u>
3.0	<u>200 TON</u>	<u>INCIDENTAL #1 STONE</u>	\$ <u>20<sup>00</sup></u> PER TON	\$ <u>4,000<sup>00</sup></u>
4.0	<u>4700 LF</u>	<u>CONSTRUCT NEW ACCESS ROAD</u>	\$ <u>26<sup>00</sup></u> PER LF	\$ <u>122,200<sup>00</sup></u>
5.0	<u>200 LF</u>	<u>18-INCH CULVERTS</u>	\$ <u>44<sup>00</sup></u> PER LF	\$ <u>8,800<sup>00</sup></u>
6.0	<u>120 LF</u>	<u>24-INCH CULVERTS</u>	\$ <u>46<sup>00</sup></u> PER LF	\$ <u>5,520<sup>00</sup></u>
7.0	LUMP SUM	<u>CLEAR AND GRUB</u>	LUMP SUM	\$ <u>10,200<sup>00</sup></u>
8.0	<u>1000 LF</u>	<u>SEDIMENT CONTROL WITH SILT FENCE AND HAYBALE DIKE (Max. Bid \$5.00 per LF)</u>	\$ <u>3<sup>00</sup></u> PER LF	\$ <u>3,000<sup>00</sup></u>
9.0		<u>REVEGETATION</u>		
9.1	<u>10 AC</u>	<u>AGRICULTURAL LIME</u>	\$ <u>600<sup>00</sup></u> PER ACRE	\$ <u>6,000<sup>00</sup></u>



PRO CONTRACTING, INC.  
 PO BOX 2442  
 CLARKSBURG, WV 26302

BUYER CB-23	PAGE 015	REQ. OR PO NO. DEP 14152
SPENDING UNIT WEST VIRGINIA DEPARTMENT OF ENVIRONMENTAL PROTECTION/SPECIAL RECLAMATION		

WV-36a STATE OF WEST VIRGINIA  
 REV. 5-1-08 PURCHASING CONTINUATION SHEET  
 VENDOR:

ITEM NO.	QUANTITY	DESCRIPTION	UNIT PRICE	AMOUNT
9.2	10 AC	<u>FERTILIZER</u>	\$ 500 <sup>00</sup> PER ACRE	\$ 5,000 <sup>00</sup>
9.3	10 AC	<u>MULCH</u>	\$ 800 <sup>00</sup> PER ACRE	\$ 8,000 <sup>00</sup>
9.4	10 AC	<u>VEGETATIVE SPECIES</u>	\$ 250 <sup>00</sup> PER ACRE	\$ 2,500 <sup>00</sup>
<u>WATER QUALITY ABATEMENT</u>				
10.0	545 LF	<u>TWO FOOT BOTTOM GROUTED RIPRAP DITCH</u>	21/10/09 \$5 \$ 63 <sup>00</sup> PER LF	\$ 34,335 <sup>00</sup>
11.0	LUMP SUM	<u>WATER TREATMENT</u>	LUMP SUM	\$ 15,000 <sup>00</sup>
12.0	LUMP SUM	<u>POND 1 ELIMINATION</u>	LUMP SUM	\$ 5,000 <sup>00</sup>
13.0	LUMP SUM	<u>WETLAND 1 ELIMINATION</u>	LUMP SUM	\$ 5,000 <sup>00</sup>
14.0	LUMP SUM	<u>WETLAND 2 MODIFICATION</u>	LUMP SUM	\$ 17,000 <sup>00</sup>
15.0	LUMP SUM	<u>WETLAND 3 MODIFICATION</u>	LUMP SUM	\$ 17,000 <sup>00</sup>
16.0	300 LF	<u>SEEP COLLECTORS</u>	\$ 86 <sup>00</sup> PER LF	\$ 25,800 <sup>00</sup>
17.0	450 LF	<u>6 INCH SDR- 35 PIPE</u>	\$ 38 <sup>00</sup> PER LF	\$ 17,100 <sup>00</sup>
18.0	LUMP SUM	<u>MANHOLE</u>	LUMP SUM	\$ 3,500 <sup>00</sup>

PRO CONTRACTING, INC.  
 PO BOX 2442  
 CLARKSBURG, WV 26302

BUYER CB-23	PAGE 016	REQ. OR PO NO. DEP 14152
SPENDING UNIT WEST VIRGINIA DEPARTMENT OF ENVIRONMENTAL PROTECTION/SPECIAL RECLAMATION		

WV-36a STATE OF WEST VIRGINIA  
 REV. 5-1-08 PURCHASING CONTINUATION SHEET  
 VENDOR:

ITEM NO.	QUANTITY	DESCRIPTION	UNIT PRICE	AMOUNT
19.0	LUMP SUM	<u>BAFFLE CURTAIN</u>	LUMP SUM	\$ 25,000 <sup>00</sup>
20.0	<u>10</u> LF (Depth)	<u>SUB-FOUNDATION PREPARATION</u>	\$ 1054 PER LF	\$ 10,540 <sup>00</sup>
21.0	LUMP SUM	<u>FOUNDATION</u>	LUMP SUM	\$ 15,282 <sup>00</sup>
22.0	LUMP SUM	<u>CRANE</u>	LUMP SUM	\$ 2,500 <sup>00</sup>
23.0	LUMP SUM	<u>DOSING UNIT AND SILO</u>	LUMP SUM	\$ 18,690 <sup>00</sup>
24.0	<u>40</u> LF	<u>4 INCH HDPE DRIVE LINE</u>	\$ 25 <sup>00</sup> PER LF	\$ 1,000 <sup>00</sup>
25.0	<u>750</u> LF	<u>6 INCH HDPE SLUDGE PIPE</u>	\$ 35 <sup>00</sup> PER LF	\$ 26,250 <sup>00</sup>
26.0	<u>400</u> LF	<u>8 INCH HDPE PIPE</u>	\$ 38 <sup>00</sup> PER LF	\$ 15,200 <sup>00</sup>
27.0	LUMP SUM	<u>SLUDGE DISPOSAL CELLS</u>	LUMP SUM	\$ 7,500 <sup>00</sup>
28.0	LUMP SUM	<u>PUMP CONNECTION END</u>	LUMP SUM	\$ 750 <sup>00</sup>
29.0	LUMP SUM	<u>WATER CONNECTION AT DISPENSING UNIT</u>	LUMP SUM	\$ 2,000 <sup>00</sup>
TOTAL PERMIT #51-78				\$ 566,365 <sup>00</sup>

BUYER CB-23	PAGE 017	REQ. OR PO NO. DEP 14152
SPENDING UNIT WEST VIRGINIA DEPARTMENT OF ENVIRONMENTAL PROTECTION/SPECIAL RECLAMATION		

WV-36a STATE OF WEST VIRGINIA  
REV. 5-1-08 PURCHASING CONTINUATION SHEET  
VENDOR:

## BID ITEM TECHNICAL SPECIFICATIONS

### **1.0 MOBILIZATION/DEMobilIZATION/PROJECT SIGN** PROJECT SIGN

A project sign shall be obtained or manufactured and installed as indicated on the attached specifications and details. Payment for this sign shall be incidental to the mobilization item. No separate payment will be made.

#### MOBILIZATION

This work shall consist of the performance of construction preparatory operations, including the movement of personnel, equipment and other facilities to the project site necessary to begin work on a substantial phase of the contract.

#### DEMobilIZATION

Prior to demobilization, an inspection shall be conducted by the Department of Environmental Protection and the contractor to insure compliance with contract performance. Once compliance is ascertained, demobilization activities can be initiated and completed. Demobilization shall be totally completed before the invoice for payment shall be processed.

#### PAYMENT

The lump sum bid for this item shall not exceed 5% of the total bid for this permit. Payment shall be made in two 50% amounts, one upon completion of the mobilization and project sign items and the second payment at the completion of demobilization. No deduction shall be made nor shall any increase be made in the lump sum item amount, regardless of decreases or increases in the final total contract amount or any other reason.

### **2.0 SPILL CONTAINMENT AREA (S.C.A.)**

Spill containment measures shall be used for fuel and lubricant storage areas. All containers, barrels, buckets, cans, etc., are to be legally disposed of off site. Used lubricants are to be disposed of according to state law to minimize pollution to the local surface and ground water supplies. Spills are the responsibility of the contractor and need immediate clean up and maintained at no expense to the State. This S.C.A. shall be constructed in accordance with the typical drawing specification. (See Attachment) Alternate containment measures will be considered for approval by the Program Manager if acceptable results can be shown. Fuel tanks manufactured with secondary containment are desirable. Minimum secondary containment is 110 percent. (Bid limited to \$1,000.00 maximum)

### **3.0 INCIDENTAL #1 STONE**

During construction of culvert installations, roadway ditch improvements, and reshaping of the roadway, areas may need additional base layer stone. After any necessary re-compaction and re-grading work on roadways has been performed by the contractor, a six (6) inch layer of #1 limestone (3.5" to 1.5" size) shall be placed as needed. This stone shall be graded and tracked in with a dozer or other equipment to achieve a compacted base for the final top layer of 1 1/2 inch crusher run limestone (separate bid item).

Payment shall be paid per ton of stone applied by weight ticket and will be made at completion of all work and acceptance by DEP.

### **4.0 CONSTRUCT NEW ACCESS ROAD**

This road will include approximately 4700 LF. Accompanying plans show the details of the construction of the road. The contractor shall provide all services, materials, construction layout, equipment, or other materials necessary to execute the work.

#### SITE PREPARATION

Any areas with soft unsuitable foundation materials shall be undercut to remove this material. The material

BUYER CB-23	PAGE 018	REQ. OR PO NO. DEP 14152
SPENDING UNIT WEST VIRGINIA DEPARTMENT OF ENVIRONMENTAL PROTECTION/SPECIAL RECLAMATION		

WV-36a STATE OF WEST VIRGINIA  
REV. 5-1-08 PURCHASING CONTINUATION SHEET  
VENDOR:

removed shall be disposed of within the construction area at a site agreed to between the contractor and the DEP on site representative. Construction stake out shall be completed as necessary to complete that phase of the work being undertaken. Payment for the road construction stakeout is to be included in the road price.

#### ROAD CONSTRUCTION

Suitable foundation material shall then be placed in compacted layers not to exceed six (6) inches in thickness to obtain the desired grade and alignment. Compaction equipment is to be approved by DEP on site representative. Filter Fabric (Tyvar 3401, Mirafi 500X, or equivalent) shall be placed over the completed foundation and covered with a six (6) inch minimum layer of No. 1 limestone (3½ to 1½ inches). The No. 1 stone shall then be covered with 1½ inch crusher run limestone so that the surface is choked off and a three (3) inch minimum layer remains on top. The completed road shall have a minimum width of twelve (12) feet and the surface shall be crowned and sloped to both sides a minimum of 24-horizontal to 1 vertical. Any fill sections, if used, shall not impound water. The total length of roadside ditch shall be along the entire length of the road. A roadside drainage ditch shall be established along the hillside of the road, and shall be free draining to any culverts crossing under the road. The ditch shall be vegetated and constructed as indicated in the New Access Road drawing.

Payment shall be for completed length of road, and shall include two truck turn-around areas paid as length of road. The first turn-around area shall be approximately twenty four (24) feet wide and ninety (90) feet in length, see Truck Turn-around Detail drawing. The second turn-around area shall be twelve (12) feet wide and fifty (25) feet in length. Both turn-around area locations shall be designated by the DEP on-site representative.

#### 5.0 18-INCH CULVERTS

The culvert shall be HDPE, dual wall smooth interior corrugated twenty (20) foot joint type. The pipe joints shall be silt-tight and the pipe shall meet ASTM D3350 manufacturing standards. The culvert locations shall be determined by the onsite DEP representative.

#### STANDARD INSTALLATION

Culverts installed in access roads shall cross the road at a 30 degree angle downgrade with a minimum grade of three percent (3%) from inlet to outlet, except in streams or diversion ditches where the pipe shall be installed straight and coincide with the normal direction of flow.

The culvert inlet and outlet ends shall be protected by a headwall of stable non-erodible material and the slope at the outlet shall be protected with an apron of rock riprap, energy dissipater or other designated material. The culvert shall be installed in a trench excavated in solid undisturbed ground or formed by compacted earth. The culvert shall be imbedded in a formed trench to a depth no less than 1/10 the outside diameter of the pipe. Selected backfill material shall be placed around the culvert in four (4) inch layers and thoroughly compacted by means of hand tamping or manually directed power tampers or plate vibrators.

The culvert shall be covered with a minimum of twelve (12) inches of material. Payment shall be for length of culvert installed, and any riprap for rock aprons, headwalls and end walls shall be incidental to this bid item.

#### 6.0 24-INCH CULVERTS

The culvert shall be HDPE, dual wall smooth interior corrugated twenty (20) foot joint type. The pipe joints shall be silt-tight and the pipe shall meet ASTM D3350 manufacturing standards. The culvert locations shall be determined by the onsite DEP representative.

#### STANDARD INSTALLATION

Culverts installed in access roads shall cross the road at a 30 degree angle downgrade with a minimum grade of three percent (3%) from inlet to outlet, except in streams or diversion ditches where the pipe shall be installed

PRO CONTRACTING, INC.  
PO BOX 2442  
CLARKSBURG, WV 26302

BUYER CB-23	PAGE 019	REQ. OR PO NO. DEP 14152
SPENDING UNIT WEST VIRGINIA DEPARTMENT OF ENVIRONMENTAL PROTECTION/SPECIAL RECLAMATION		

WV-36a STATE OF WEST VIRGINIA  
REV. 5-1-08 PURCHASING CONTINUATION SHEET  
VENDOR:

straight and coincide with the normal direction of flow.

The culvert inlet and outlet ends shall be protected by a headwall of stable non-erodible material and the slope at the outlet shall be protected with an apron of rock riprap, energy dissipater or other designated material. The culvert shall be installed in a trench excavated in solid undisturbed ground or formed by compacted earth. The culvert shall be imbedded in a formed trench to a depth no less than 1/10 the outside diameter of the pipe. Selected backfill material shall be placed around the culvert in four (4) inch layers and thoroughly compacted by means of hand tamping or manually directed power tampers or plate vibrators.

The culvert shall be covered with a minimum of twelve (12) inches of material. Payment shall be for length of culvert installed, and any riprap for rock aprons, headwalls and end walls shall be incidental to this bid item.

#### **7.0 CLEAR AND GRUB**

All vegetative cover (trees, shrubs, bushes, etc.) within the entire work area shall be removed to bare ground. It is the contractor's responsibility to obtain all necessary permits and to follow state guidelines for burning and proper disposal of vegetative materials. Disposal of the trees and shrubs on-site with a chipper is an acceptable alternative to burning.

#### **8.0 SEDIMENT CONTROL WITH SILT FENCE AND HAYBALE DIKE**

Disturbed areas which have storm water runoff and does not pass through a sediment control structure shall utilize the following Best Management Practice (BMP) methods to manage storm water runoff. For more information on BMP methods go to the WVDEP website <http://www.wvdep.org/dwvm/stormwater/BMP.htm> and click on **BMP Manual**. The WV Erosion and Sediment Control Best Management Practice Manual may be accessed or printed. This item has a Maximum Bid of \$5.00/LF of silt fence and hay bale material used on site.

1. Silt fence shall be utilized on perimeter barriers and shall be properly removed after permanent vegetation has been established. See attached drawing for further details.
2. For slope stability, place bales on the contour; at the top of cuts; and at the toe of slopes. Bales shall be placed in a row with ends tightly abutting the adjacent bales.
3. Bales shall be securely anchored in place by stakes or rebar driven through the bales. Rebar shall be removed at the direction of DEP. The first stake in each bale shall be driven toward previously laid bale to force the bales together.
4. Construction of sediment control sumps before culvert inlets and/or rock check dams in ditch lines may become necessary to supplement the silt fence and hay bale dikes. These items shall be installed upon request of the DEP onsite representative. Sumps and rock check dams shall be incidental to this bid item.

#### **9.0 REVEGETATION**

The actual seeding date, within the work performance period, shall be at the discretion of the contractor, but a permanent vegetative cover must be established. Verification of materials used shall be required for payment. Seed bed preparation, unless otherwise approved, shall be conducted by industrial disks or tracking with heavy equipment with cleat marks across slope and parallel to the final contours. The surface shall be tracked, track to track. Seeding shall commence after seedbed preparation on a loose and uncompacted soil and with the approval of the Department of Environmental Protection. Contractor shall provide equipment as necessary to secure approval of the seedbed. Revegetation activities shall be carried out in a continuous, concurrent, timely and uniform manner. Failure to do this may result in nonpayment for portions of or the entire Revegetation item. Hydro seeding or broadcast seeding

PRO CONTRACTING, INC.  
PO BOX 2442  
CLARKSBURG, WV 26302

BUYER CB-23	PAGE 020	REQ. OR PO NO. DEP 14152
SPENDING UNIT WEST VIRGINIA DEPARTMENT OF ENVIRONMENTAL PROTECTION/SPECIAL RECLAMATION		

WV-36a STATE OF WEST VIRGINIA  
REV. 5-1-08 PURCHASING CONTINUATION SHEET  
VENDOR:

with the approved species is acceptable. The application rate may be increased but the ratio is to remain constant, but no additional monetary compensation will be awarded. Areas outside the limits of construction, disturbed by the contractor, shall be revegetated by the contractor at no expense to DEP. Water utilized for hydro seeding shall be free of injurious or other toxic substances harmful to plant life. The source of water is subject to the approval of the DEP Specialist. It shall be the vendor's responsibility to repeat the procedures under REVEGETATION until permanent vegetation is established. The acreage quantities in this contract are for bidding purposes only.

A warranty period of one (1) year shall commence upon completion and payment of the revegetation item of the contract. No payment will be made for additional seeding necessary to comply with warranty requirements. The warranty period will be extended for one (1) year from the date of the last augmented seeding done by the contractor. The performance bond and labor and materials bond shall remain in effect throughout the warranty period. The Standards for Evaluating Vegetative Cover as presented in Title 38, CSR2, Section 9 of the West Virginia Surface Mining Reclamation Regulations will apply.

Equipment for the retracking/scarification to eliminate rills and gullies shall be mobilized and utilized to produce slopes consistent with the regrading and top soiling bid item prior to warranty reseeding. No additional payment will be made by DEP for this warranty work.

### 9.1 AGRICULTURAL LIME

Unless otherwise specified, all lime used shall be registered with the West Virginia Department of Agriculture, have an 85% minimum calcium carbonate equivalent, and meet the fineness classification no larger than that for ground lime. The following fineness classifications or combinations of lime are acceptable:

- Pulverized - 100% passing a U.S. Standard 20 mesh sieve  
70% passing a U.S. Standard 100 mesh sieve
- Ground - 90% passing a U.S. Standard 20 mesh sieve  
- 50% passing a U.S. Standard 60 mesh sieve  
- 35% passing a U.S. Standard 100 mesh sieve

Use of blends and low-grade agricultural liming materials shall require prior approval. Lime shall be spread as soon as possible after delivery to site. Lime shall be applied evenly and uniformly distributed over the treated area. Lime shall be thoroughly mixed into the soil material. Lime subjected to adverse conditions before spreading will be deemed unacceptable. Failure to complete this phase shall result in nonpayment of this bid item.

Lime shall be applied at 10 ton/acre.

### 9.2 FERTILIZER

Fertilizer rates given for REVEGETATION are for 1,000 lbs. of 10-20-10 per acre. These rates are minimum and for bidding purposes.

Fertilizer shall be applied evenly and uniformly distributed over the treated area. Common complete fertilizers which meet the minimum standards are acceptable.

### 9.3 MULCH

Acceptable mulch for this project is wood fiber, hay, or straw.

Mulch: Wood Fiber @ 1.0 ton/Acre

Hay or straw mulch may be substituted at a rate of 1 tons/Acre.

PRO CONTRACTING, INC.  
PO BOX 2442  
CLARKSBURG, WV 26302

BUYER CB-23	PAGE 021	REQ. OR PO NO. DEP 14152
SPENDING UNIT WEST VIRGINIA DEPARTMENT OF ENVIRONMENTAL PROTECTION/SPECIAL RECLAMATION		

WV-36a STATE OF WEST VIRGINIA  
REV. 5-1-08 PURCHASING CONTINUATION SHEET  
VENDOR:

#### 9.4 VEGETATIVE SPECIES

Seeding rate required is for pure live seed (pls) in pounds per acre. The use of annuals or cover crops will not be considered for vegetative success.

##### NORTH MIX

<u>VEGETATIVE SPECIES</u> <sup>1</sup>	<u>RATE/ACRE</u> <sup>1</sup>
Birds foot Trefoil	@ 30 lbs/acre
Weeping Lovegrass <sup>2</sup>	@ 3 lbs/acre
Red Top <sup>3</sup>	@ 10 lbs/acre
Ky 31 Fescue	@ 35 lbs/acre

1. Seeding rate suggested is for pure live seed (pls) in pounds per acre.
2. Spring mix.
3. Fall mix.

#### 10.0 TWO-FOOT BOTTOM GROUDED TRAPAZOIDAL RIPRAP DITCH

This ditch shall be approximately 545 linear feet (LF). Provide all materials, excavate and construct the two-foot bottom grouted trapezoidal riprap ditch as indicated on the attached typical plans, cross-section, specifications, and as discussed at the Pre-Bid Showing. Ditches shall be free draining upon completion of construction. Length of ditch may be adjusted to meet on site conditions. R-5 limestone riprap shall be used at a thickness of 1.5 foot.

The grout filler shall be composed of a mixture of one part Type II (sulfate resistant) Portland cement and three parts sand, mixed with water to produce a workable consistency. The stone shall be thoroughly wet immediately before grout is applied. As soon as the grout is deposited on the surface, it shall be thoroughly worked into the joints. The stones shall then be brushed, so that their top surfaces are exposed. Grout shall penetrate 100% of the riprap thickness.

Payment shall be per linear feet of channel installed.

#### 11.0 WATER TREATMENT

This site currently consists of one settling pond followed by three constructed wetlands. All structures must be dewatered. During dewatering the contractor shall maintain a pH between 6 and 9 and utilize drainage control measures for suspended solids. Payment for this item shall be lump sum at completion of all dewatering activities.

#### 12.0 POND 1 ELIMINATION

Pond 1 shall be cleaned to original ground. All pond cleanings shall be disposed at the location depicted on the site plans (Site Layout drawing). Upon completion the area shall then be regarded to obtain an approximate 5% grade from the foundation of the treatment building to the entrance of the newly established Pond 1 (see Wetland 2 Modification).

#### 13.0 WETLAND 1 ELIMINATION

Wetland 1 shall be cleaned to original ground. Upon completion the area shall then be regarded to obtain an approximate 5% grade from the foundation of the treatment building to the entrance of the newly established Pond 1 (see Wetland 2 Modification bid item).

PRO CONTRACTING, INC.  
PO BOX 2442  
CLARKSBURG, WV 26302

BUYER CB-23	PAGE 022	REQ. OR PO NO. DEP 14152
SPENDING UNIT WEST VIRGINIA DEPARTMENT OF ENVIRONMENTAL PROTECTION/SPECIAL RECLAMATION		

WV-36a STATE OF WEST VIRGINIA  
REV. 5-1-08 PURCHASING CONTINUATION SHEET  
VENDOR:

#### **14.0 WETLAND 2 MODIFICATION**

Wetland 2 shall be excavated to create a new Pond 1. All organic material removed from the wetland shall be disposed at the location depicted on the site plans (see Site Layout drawing). Pond 1 shall then be excavated to a total depth of ten feet (10 ft), consisting of an eight foot water depth and two foot of freeboard. This area shall also be enlarged to obtain final dimensions of sixty-two feet wide by one hundred and sixteen feet in length (62 ft X 116 ft). All side slopes shall be two horizontal to one vertical (2h:1v).

#### **15.0 WETLAND 3 MODIFICATION**

Wetland 3 shall be excavated to create Pond 2. All organic material removed from the wetland shall be disposed at the location depicted on the site plans (see page 31). Pond 2 shall then be excavated to a total depth of ten feet (10 ft), consisting of an eight foot water depth and two foot of freeboard. This area shall also be enlarged to obtain final dimensions of fifty feet wide by one hundred and forty feet in length (50 ft X 140 ft). All side slopes shall be two horizontal to one vertical (2h:1v).

#### **16.0 SEEP COLLECTORS**

Five seep collectors shall be constructed according to the lengths indicated on the site plans (see Site Layout drawing). Upon exiting the seep collectors, all water conveyance shall be through six inch SDR-35 PVC pipe. Seep collectors 1, and 5 shall convey all drainage to the manhole. Seep collector 4 shall convey all drainage directly through the treatment building. Drainage exiting seep collectors 2 and 3 shall be directed to the two foot bottom grouted riprap ditch. Each seep collector shall be 4 ft. X 4 ft. in cross-section. Stone for the collectors shall be non-calcareous with a size of 3" to 6" in diameter. The seep collectors shall be wrapped with filter fabric (Tyvar 3401 or equivalent). Filter fabric may be omitted from areas where the seepage enters the seep collector if approved by the DEP on site representative. A 6" perforated SDR-35 PVC pipe shall extend the length of the collector and connect to solid pipe, exiting the collectors. Upon exiting the seep collectors any additional solid 6" SDR-35 PVC pipe shall be covered under a separate bid item. The perforated end of the 6" pipe shall extend to the surface as a clean-out with 6" diameter pipe and cap. A 40 mil HDPE synthetic liner (or equivalent) shall cover the bottom and lower side/ends of the seep collectors.

Cover the collectors with a minimum of 1.0 foot of material and grade the surface so it is well drained. Material on the down slope side of the collector shall be impervious to prevent leakage from the collectors to the surface. Provide all fittings necessary for installation. Refer to the attached drawing for further details. All materials specified above and on the attached drawing shall be incidental to this bid item, unless stated otherwise. Payment for each seep collector is by linear foot upon completion, and verification by DEP with photos.

#### **17.0 6 INCH SDR-35 PVC PIPE**

The 6 Inch SDR-35 PVC pipe will be used to convey all drainage exiting the seep collectors to each of the destinations mentioned in the Seep Collector bid item. Approximately three hundred and sixty (360) linear feet will be required. This pipe shall be buried at least 2.5 feet deep to prevent freezing. Animal guards shall be installed at the exit of each pipe, and shall day light into an open channel. Payment for this bid item shall be for the actual length of pipe installed.

#### **18.0 MANHOLE**

The manhole shall be "Type A" as specified by the West Virginia Department of Highways or shown on drawings. The elevation of the manhole shall be determined according to the invert of the 6 inch SDR-35 PVC pipe exiting seep collector #5 (see Profile drawing). Excavation shall be done to the elevation determined by the seep collector excavation. Undercutting shall be required if competent foundation conditions are not encountered. Compacted crushed stone shall be placed under manhole for bedding. The lid and ring shall be of standard cast iron construction and shall be watertight with bolt anchors in the concrete. Entrance pipes shall extend four (4) inches past the manhole wall. The exit pipe is a 6" SDR 35 pipe. This pipe shall be paid under a separate bid item. Ensure that the exit pipe is sealed into the manhole wall. The purpose of the manhole is to establish a collection point to



PRO CONTRACTING, INC.  
PO BOX 2442  
CLARKSBURG, WV 26302

BUYER CB-23	PAGE 023	REQ. OR PO NO. DEP 14152
SPENDING UNIT WEST VIRGINIA DEPARTMENT OF ENVIRONMENTAL PROTECTION/SPECIAL RECLAMATION		

WV-36a            STATE OF WEST VIRGINIA  
REV. 5-1-08      PURCHASING CONTINUATION SHEET  
VENDOR:

drive the dosing unit while maintaining minimal slope from the seep collector. Also, the manhole shall serve as an entry point to perform maintenance on the conveyance pipes. See detail sheet for layout and desired location. Payment shall be made upon completion of installation of the manhole and 6" SDR 35 pipe.

### **19.0 BAFFLE CURTAIN**

Three baffle curtains shall be installed at this site. The baffle curtains shall be of an ultraviolet (UV) resistant type vinyl coated polyester material with a minimum total weight rating of 17 oz. /sq. yd. Styrofoam floats of minimum size 3"x4"x24" shall be hot seam sealed into the top of baffle curtain, and shall be evenly spaced 4 inches apart end to end. A grommet shall be placed between each of the Styrofoam floats. A 5/16 inch diameter stainless steel wire cable shall be seamed into the top of the baffle to anchor at the sides of the pond. The cable and bottom chain shall extend 10 feet past the cut length of the baffle curtain on each end. A 1/4 inch diameter link chain shall be hot seam sealed into the bottom of the baffle for weight, and to anchor at the sides of the pond. Chain shall be bolted at each end through the top hot seam to create another anchor point for the curtain. Secure anchor points (pipe, rods, or treated posts) shall be installed at the ponds edge to hold the baffle in place. Anchor points and the baffle location shall be approved by the DEP onsite representative before installation. The wire cable and chain shall be attached in such a way to allow for easy disconnect while sludge is being pumped from the pond. All cable fasteners, eye bolts, and other accessories shall be stainless steel to prevent corrosion, and shall be incidental to this pay item. The baffle curtains opening slots shall be cut into the curtain below the hot seam seal at the top of the baffle, as indicated on the attached drawing. The spacing and the size of the slots shall be determined by the DEP engineer or onsite representative, and shall be installed at the time of installation. Payment shall be lump sum, and shall include all posts, anchors, fasteners, chain, and cable required to secure baffles in place. Baffle curtains shall be installed at three different locations. The approximate total length of curtain is 180 linear feet.

### **20.0 SUB-FOUNDATION PREPARATION**

The sub-foundation shall be undercut to remove all fill (unconsolidated material) down to a competent foundation as determined by the DEP on site representative. The sub-foundation shall be constructed in substantial conformity to the plans and/or specifications. The DEP on site representative shall be present during this work. The sub-foundation material shall be suitable material free of particles larger than three inches in diameter and consist of granular material conforming to WVDOH specification 716.1.1.2. A bearing capacity of approximately 6 tons per square ft should be obtained.

Compaction shall be done with a suitable compactor to obtain approximately 98% Standard Proctor Density. Layers shall be six (6) inches or less in thickness before compaction is initiated. Moisture content of the fill material shall be controlled to obtain maximum compaction.

Payment shall be made for each one (1) foot depth of undercut required.

### **21.0 FOUNDATION**

The foundation shall be Type II (Sulfate Resistant) Concrete and shall conform to the dimensions and shape shown in the detail drawings and specifications. Include all reinforcing bars with supports and anchor bolts as necessary. Provide all forms, personnel and equipment required for the placement, finishing, and curing of the concrete. The concrete shall be consolidated with use of an internal spud vibrator to liquefy the concrete so that entrapped air and water can come to the surface. Also, supplement the mechanical vibrator by hand-spading, Roding, or tamping. Adverse weather conditions shall be avoided during completion of this item. WVDOH specifications (Section 601-Construction Manual) for concrete shall apply to this item. Concrete shall cure for a minimum of 5 to 7 days before the silo may be erected in place. Excavation for the foundation is incidental to this item with no separate payment being made. Concrete shall meet minimum 28-day compressive test strength of 4000 psi, and the slump shall be between 2 and 3 inches during placement of concrete.

The channel in the foundation is to receive water from the manhole and seep collector #4 with solid 6 inch

PRO CONTRACTING, INC.  
PO BOX 2442  
CLARKSBURG, WV 26302

BUYER CB-23	PAGE 024	REQ. OR PO NO. DEP 14152
SPENDING UNIT WEST VIRGINIA DEPARTMENT OF ENVIRONMENTAL PROTECTION/SPECIAL RECLAMATION		

WV-36a STATE OF WEST VIRGINIA  
REV. 5-1-08 PURCHASING CONTINUATION SHEET  
VENDOR:

pipng. After treatment with the reagent, the water will exit the foundation into a two foot bottom grouted trapezoidal riprap ditch (separate bid item). This item shall be paid for as a lump sum item after completion of the foundation and acceptance by the DEP.

## 22.0 CRANE

This shall include furnishing a crane of sufficient capacity to unload and erect the silo structure on its foundation and to install the reagent dispensing unit. The silo is estimated to weigh less than 10 ton. Payment for this work shall be made based on the lump sum contract and paid upon final acceptance by DEP.

## 23.0 DOSING UNIT AND SILO

This item includes all work necessary to purchase, install and initiate operation of an Aqua fix water powered dosing unit (Unit type MSS-SM-OA-20). This item shall be subcontracted to:

Aqua-Fix Water Treatment Systems.  
Michael Jenkins  
301 Maple Lane  
Kingwood, WV 26537 Telephone: (304) 329-1056.

Structural elements shall be warranted by the manufacturer to withstand normal static and dynamic loads as commonly accepted by industry. Changes to these specifications shall be made only with the written approval of the Program Manager.

A 20 ton steel silo to store the reagent is required. The silo shall be equipped with an interior ladder, an exterior ladder with a protective cage and a lockable steel safety door, a steel safety fence around the top of the silo, and a filler pipe to extend to the unloading port. A steel cone shall be placed at the base of the silo to direct the discharge of the reagent through a steel flange, which is sized and located to accommodate the reagent dispensing unit. Silo shall include a vent pipe to prevent pressure buildup during filling. An emergency pop off valve shall be included in case the vent pipe malfunctions. Pneumatic filling of the silo is to be utilized.

An insulated steel security enclosure attached to the silo structure support system to protect the dosing unit from vandalism and the weather is required. The wall thickness of the silo enclosure shall be equivalent to the steel used in the construction of the silo. The enclosure shall be equipped with a hinged, lockable steel door of sufficient size to facilitate removal of the dosing unit for repair and/or future replacement. The enclosed structure shall be fitted with a propane heating unit with a capacity to prevent freezing of the dosing unit during the winter. The heater will include all needed piping, regulator and fittings to connect to the tank. A 100 gallon tank shall be included, and will need to be filled one time.

Painting of the silo and steel security enclosure shall be done in accordance with WVDOH Specification 711. Preferred colors are green and/or tan.

The dosing unit, silo, and filler pipe shall be designed to facilitate the use of Calcium Oxide (CaO) during the service life of the unit. A water line will be installed to power the water wheel. This portion of the work shall include the initial filling and the start up of the unit, at the direction of the Program Manager, to confirm that all units function as intended. Any repairs and/or adjustments required to the unloading system and dosing unit to allow them to function as designed shall be performed at no cost to the DEP. The system shall be operated successfully for a one-week period before acceptance by the DEP. All settling ponds and riprap ditches leading to them must be completed before testing is initiated. The Calcium Oxide shall be 20 tons in amount and delivered as scheduled by the onsite DEP representative.

Payment for all of the work specified above shall be made based on the lump sum contract price.

PRO CONTRACTING, INC.  
PO BOX 2442  
CLARKSBURG, WV 26302

BUYER CB-23	PAGE 025	REQ. OR PO NO. DEP 14152
SPENDING UNIT WEST VIRGINIA DEPARTMENT OF ENVIRONMENTAL PROTECTION/SPECIAL RECLAMATION		

WV-36a            STATE OF WEST VIRGINIA  
REV. 5-1-08      PURCHASING CONTINUATION SHEET  
VENDOR:

#### **24.0 4 INCH HDPE DRIVE LINE**

This pipe will lead from the manhole to the treatment building. Approximately 30 LF will be required. Pipe shall be 4-inch diameter, SDR-15.5 or 17 HDPE of standard manufacture. Install to manufacturers recommendations. Install the pipe as indicated in the specifications and/or as shown on the drawings. Payment is for the actual length of pipe installed. This 4-inch HDPE pipe shall be used for drive line to power the dispensing unit. Provide all materials, equipment and personnel necessary for installation. Pipe shall be buried at least 2.5 feet deep. Use butt weld fusion process to join pipes. A qualified fusion technician shall supervise the fusion of all joints. See site plan for location.

#### **25.0 6 INCH HDPE SLUDGE PIPE**

Pipe shall be 6 inch diameter, SDR 15.5 or 17 HDPE of standard manufacture. Install to manufacturers recommendations. Install the pipe as indicated in the specifications and/or as shown on the drawings.

Payment shall be for the actual length of pipe installed. This 6 inch HDPE pipe shall be used for sludge line. Provide all materials, equipment and personnel necessary for installation. Pipe shall be buried at least 2.5 feet deep. Use butt weld fusion process to join pipes. A qualified fusion technician shall supervise the fusion of all joints. See site plan for location.

#### **26.0 8 INCH HDPE PIPE**

This 8 inch HDPE pipe shall be used as an emergency spillway from the sludge cells during pumping activities. The pipe shall be SDR 15.5 or 17.0 HDPE of standard manufacture. Provide all materials, equipment and personnel necessary for installation. Pipe shall be buried at least 2.5 feet deep. Use butt weld fusion process to join pipes. A qualified fusion technician shall supervise the fusion of all joints. Payment shall be for the actual length of pipe installed. See site plan for location.

#### **27.0 SLUDGE DISPOSAL CELLS**

Two sludge disposal cells shall be constructed to receive sludge pumped from the settling ponds. These cells shall have a completed holding capacity of at least 30,000 cubic feet. Each constructed cell shall have a fifty (50) foot top width, a top length of one hundred (100) feet, and a total depth of ten (10) feet, including two feet of freeboard. The sludge disposal cells shall have side slopes not exceeding one horizontal to one vertical. The cells shall be constructed in the area between seep collector 1 and the existing rock lined diversion ditch. Material which is removed during construction shall be utilized on-site. The emergency spillway shall consist of a 8 inch diameter, SDR 15.5 or 17 HDPE pipe which will convey the overflow back down to the two foot bottom grouted trapezoidal ditch leading to Pond 1. This pipe shall be paid under a separate bid item. Lump sum payment shall be for the completed item upon approval of the DEP on site representative.

#### **28.0 PUMP CONNECTION END**

The settling pond end of the HDPE 6 inch diameter pipe shall be fitted with a 6 inch HDPE wye incorporating a six by two inch HDPE reducer. The two inch shall then be fitted with a stainless steel (SS) national pipe thread (NPT) end to accommodate a two inch SS ball valve. The six inch end shall include a SS, NTP end to receive a 6 inch cam-lock adaptor (see attached drawing). Install posts or pipes to protect outlet from damage. Use riprap around pipe as necessary to accommodate access to the valve. Include a cam-lock cap for sealing the adaptor. Payment for this item shall be lump sum.

#### **29.0 WATER CONNECTION AT DISPENSING UNIT**

At the dispensing unit, the 4-inch diameter HDPE line (separate bid item) shall be connected with a four (4) inch True union PVC ball valve and a two (2) inch True union PVC ball valve, various HDPE fittings (see Drive Line Schematic drawing), cleanouts, molded elbows, caps, reducer fittings, and flanges to supply water to the unit. This is a lump sum payment upon completion of work. All material costs are incidental to this bid item.

PRO CONTRACTING, INC.  
PO BOX 2442  
CLARKSBURG, WV 26302

BUYER CB-23	PAGE 026	REQ. OR PO NO. DEP 14152
SPENDING UNIT WEST VIRGINIA DEPARTMENT OF ENVIRONMENTAL PROTECTION/SPECIAL RECLAMATION		

WV-36a STATE OF WEST VIRGINIA  
REV. 5-1-08 PURCHASING CONTINUATION SHEET  
VENDOR:

---

## BID PREPARATION INFORMATION

### HISTORICAL INFORMATION

Prospective bidders may review files at the West Virginia Department of Environmental Protection, Charleston, WV office, or the Regional West Virginia Department of Environmental Protection Office at 105 South Railroad St., Philippi, WV 26416. These files may contain additional information not included in the contract. Documents including, but not limited to, permit applications, permits, inspection reports, environmental documents, permit violation history, geological and geotechnical information, probable hydrologic consequences, maps, modifications, NPDES information and other related data. Copies may be obtained upon request and payment of copying fees.

### EXAMINATION OF BID PACKAGE AND SITE OF WORK

The bidder is required to examine, carefully, the bid package (plans, specifications, supplemental specifications, contract forms, etc.) and the site of the work contemplated. The submission of a bid shall be considered prima facie evidence that the bidder has made such examination and has judged for and satisfied themselves as to the character, quantity, and quality of work to be performed and the materials required to be furnished under the contract.

### PREBID CONFERENCE

Only the prospective bidders on the sign-in sheet in attendance for the entire Pre-Bid Conference will be eligible to submit bids for consideration of this project. Considerable foot travel over rough terrain and/or inclement weather may be required.

### VIDEO

The information given at the pre-bid showing by the project contact person or the assigned person shall be documented on video tape and shall be an integral part of this contract's requirements, but will not supersede the written contract. All information on video tape that is new or provides clarification to the specifications will be issued in writing by a formal addendum and will become part of the written contract.

### INTENT OF CONTRACT

The intent of the contract is for the reclamation/restoration of forfeited mine lands as required by West Virginia Department of Environmental Protection. The contractor is to provide for the construction and completion in every detail of the work described. The Contractor shall furnish all labor, materials, equipment, tools, transportation, and supplies required to complete the work in accordance with the Plans, Specifications, and terms of the Contract. Should any misunderstanding arise as to the intent or meaning of the Contract, or any discrepancies appear, the decision of the Director of Division of Land Restoration shall be final.

PRO CONTRACTING, INC.  
PO BOX 2442  
CLARKSBURG, WV 26302

BUYER CB-23	PAGE 027	REQ. OR PO NO. DEP 14152
SPENDING UNIT WEST VIRGINIA DEPARTMENT OF ENVIRONMENTAL PROTECTION/SPECIAL RECLAMATION		

WV-36a      STATE OF WEST VIRGINIA  
REV. 5-1-08      PURCHASING CONTINUATION SHEET  
VENDOR:

---

## GENERAL PERFORMANCE STANDARDS

### INTRODUCTION

The performance standards and non-compliance penalties which govern special reclamation-bond forfeiture projects are in Chapter 22A, Article 3, of the Code of West Virginia and subsequent rules and regulations. The following performance standards are of a general nature and do not represent all the performance standards applicable to a special reclamation-bond forfeiture project. However, some or all of these standards will pertain to each project.

### BACKFILLING

1. Unless otherwise noted, the high wall shall be eliminated and the disturbed area graded to the approximate original contour.
2. The material used to backfill and eliminate the high wall shall be sufficiently compacted so as to insure stability of the backfill throughout the warranty period.
3. The land above the high wall shall not be disturbed unless otherwise directed.
4. The best available material to support vegetation, sufficient to establish a permanent vegetative cover and to achieve the approved post mining land use, shall be used.

### BLASTING

The performance standards of the blasting regulations must be adhered to.

### LIFE OF CONTRACT

The purchase order contract becomes effective on the starting date as specified in the notice to proceed as issued by the Department of Environmental Protection. This contract extends for a period of one (1) year and may be renewed until such "reasonable time" thereafter as is necessary to complete the payment therefore. A responsible Contractor's Agent shall be on the site at all working times that demonstrates knowledge of mined land reclamation, contract requirements and responds to DEP (owner) inspections.

### WORK PERFORMANCE PERIOD

The work performance period is a defined portion of the contract in which all items shall be completed. The work performance period is to be performed within 365 calendar days. Extensions may be granted based upon contractor's performance, weather conditions and site-specific site conditions.

### NOTICE TO PROCEED

A notice to proceed shall be issued to the Contractor by the project contact person for the Department of Environmental Protection. Actual construction may only begin after a Notice to Proceed is given and as specified. Such notice shall specify the starting date of the Purchase Order, the work performance period, and the completion date of the work performance period.

### PRE-CONSTRUCTION CONFERENCE

The Contractor in possession of the awarded purchase order shall schedule a Pre-Construction Conference on the site within ten (10) days after receiving the Notice to Proceed. The Contractor's foreman or the on-the-ground supervisor must be in attendance.

PRO CONTRACTING, INC.  
PO BOX 2442  
CLARKSBURG, WV 26302

BUYER CB-23	PAGE 028	REQ. OR PO NO. DEP 14152
SPENDING UNIT WEST VIRGINIA DEPARTMENT OF ENVIRONMENTAL PROTECTION/SPECIAL RECLAMATION		

WV-36a STATE OF WEST VIRGINIA  
REV. 5-1-08 PURCHASING CONTINUATION SHEET  
VENDOR:

### **GENERAL SUPERVISION**

This contract is under the general supervision of the West Virginia Department of Environmental Protection's contact person for the purpose of contract compliance inspection only. Contractor shall supervise work being conducted at all times. All services rendered by the Engineer/Contact Person consist of professional opinions and recommendations made in accordance with generally accepted engineering practice. Under no circumstances is it the intent of the Engineer/Contact Person to directly control the physical activities of the Contractor or the Contractor's workmen's accomplishment of work on this project.

### **CONTRACTOR RESPONSIBILITY**

The contractor is responsible for compliance with all aspects of this written contract. No changes will be honored without prior approval from the Program Supervisor.

### **LAWS TO BE OBSERVED**

The Contractor shall keep fully informed of all Federal and State laws, all local laws, ordinances, and regulations and all orders and decrees of bodies or tribunals having any jurisdiction or authority, which in any manner affect those engaged or employed on the work, or which in any way affect the conduct of the work. The Contractor shall at all times observe and comply with all such laws, ordinances, regulations, orders and decrees; and shall protect and indemnify the State and its representatives against any claim or liability arising from or based on the violation of any such laws, ordinances, regulations, orders, or decrees, whether by themselves, their subcontractors or their employees.

### **PERMITS, LICENSES AND TAXES**

The Contractor shall procure all permits and licenses, pay all charges, fees, and taxes, and give all notices necessary and incidental to the due and lawful prosecution of the work.

### **CONCURRENT RECLAMATION**

Reclamation of this project shall commence at a definite point as defined and shall progress from that point with total reclamation to include backfilling, grading/regarding, and revegetation. Changes may be granted based upon weather or differing site conditions with prior approval.

### **WATER QUALITY CONTROL**

Shall commence with initial start-up of the project and remain in effect for the extent of the backfilling, regrading and revegetation activity. DEP obtains a storm water permit for each project from the Water Resources Division. (General Water Pollution Control Permit WVO115924) The Contractor is responsible for performing the best management practices. Adequate facilities shall be installed, operated and maintained using the best management practices of the U.S. Environmental Protection Agency's Non-Point Source (NPS) Program for sediment control during the active reclamation. The contractor shall take any and all steps necessary to prevent erosion or silting problems from occurring and to minimize pollution or sedimentation of the stream. If any such problems develop, the contractor shall be responsible to take immediate corrective action. No separate payment for this work will be honored. All impounded waters which require removal during reclamation, shall be pumped with appropriate measures taken to prevent erosion from the discharge. The contractor shall be responsible for treatment of said waters to meet pH standards. The water shall be discharged only when the quality meets a pH equivalent to the pH of the receiving stream but not less than 6.0.

### **DIFFERING SITE CONDITIONS**

During the progress of the work, if subsurface or latent physical conditions are encountered at the site differing materially from those indicated in the contract or if unknown physical conditions of an unusual nature, differing materially from those ordinarily encountered and generally recognized as inherent in the work provided by the

PRO CONTRACTING, INC.  
PO BOX 2442  
CLARKSBURG, WV 26302

BUYER CB-23	PAGE 029	REQ. OR PO NO. DEP 14152
SPENDING UNIT WEST VIRGINIA DEPARTMENT OF ENVIRONMENTAL PROTECTION/SPECIAL RECLAMATION		

WV-36a STATE OF WEST VIRGINIA  
REV. 5-1-08 PURCHASING CONTINUATION SHEET  
VENDOR:

contract, are encountered at the site, the party discovering such conditions shall promptly notify the other party in writing of the specific differing conditions before they are disturbed and before the affected work is performed.

Upon written notification, the Engineer/Contact Person will investigate the conditions, and if determined that the conditions materially differ and cause an increase or decrease in the cost or time required for the performance of any work under the contract, an adjustment, excluding loss of anticipated profits, will be made and the contract modified in writing accordingly. The Engineer/Contact Person will notify the Contractor of DEP's determination whether or not an adjustment of the contract is warranted.

No contract adjustment which results in a benefit to the Contractor will be allowed unless the Contractor has provided the required written notice. No contract adjustment will be allowed under this clause for any effects caused on unchanged work.

#### **HANDLING AND STORAGE OF MATERIALS**

Materials which are stored on site, before utilization, shall be stored so as to assure the preservation of their quality and fitness for the work. Stored materials, even though approved before storage, may be inspected again prior to their use in the work. Damaged or deteriorated materials shall be removed and replaced by materials meeting the original specifications.

Aggregate stockpiles shall be made on ground that is denuded of vegetation, hard, and well drained. Removal of aggregate from the stockpile shall be done in a manner which will not result in the inclusion of foreign material into the aggregate. The use of the aggregate will determine if exceptions are permitted. All materials shall be handled in such a manner as to preserve their quality and fitness for the work.

#### **MAINTENANCE DURING CONSTRUCTION**

The contractor shall maintain the work during construction and until the project is accepted. All cost of maintenance work during construction and before the project is accepted shall be included in the unit or lump sum prices on the various pay items.

#### **FINAL INSPECTION**

A final inspection meeting by the Department of Environmental Protection's Specialist and the contractor is required for the construction phase and prior to demobilization.

#### **ACREAGE QUANTITIES**

The acreage quantities in this contract are for bidding purpose and are set (definite) number for the project area as specified at the pre-bid showing. Only surveyed acreage's through figures the Contractor and/or the State develops will be honored to alter these acreage numbers.

#### **PAYMENT**

Invoices must be submitted on prescribed Department of Environmental Protection; Special Reclamation Program forms and include verification. Certified contractor payrolls for operators directly involved in this project and a current workers compensation certificate must accompany each invoice for payment. Verification of wage rates may include employee interviews. Invoices shall be signed in blue ink so that it is easy to verify that document is an original.

MOBILIZATION/DEMobilIZATION shall be invoiced at fifty percent (50%) with the first invoice and the last 50% invoiced after demobilization and acceptance of the road abandonment or final invoice. Demobilization must have written approval.

SPILL CONTAINMENT AREA shall not exceed \$1,000.00 and will be payable in two payments. The first fifty

PRO CONTRACTING, INC.  
PO BOX 2442  
CLARKSBURG, WV 26302

BUYER CB-23	PAGE 030	REQ. OR PO NO. DEP 14152
SPENDING UNIT WEST VIRGINIA DEPARTMENT OF ENVIRONMENTAL PROTECTION/SPECIAL RECLAMATION		

WV-36a STATE OF WEST VIRGINIA  
REV. 5-1-08 PURCHASING CONTINUATION SHEET  
VENDOR:

percent (50%) payable with the first invoice and the remainder payable when all fuel tanks, containers and etc., are removed from the site.

Lump sum items shall be percentage payments based on work completed at time of invoice and paid upon acceptance by the Department of Environmental Protection.

Unit items shall be invoiced by specified units completed and accepted by the DEP.

ROAD ABANDONMENT shall be included in the final construction invoice.

#### **FAILURE TO COMPLETE ON TIME AND LIQUIDATED DAMAGES**

Time is an essential element of the Contract and it is important that the work be completed within the time specified. The cost to the Department of the administration of the Contract, including engineering, inspection and supervision, will increase as the time required to complete the work is increased.

The work performance period as specified in the contract's Notice to Proceed shall be complied with or result in liquidated damages. Such damages shall be assessed at an amount of two hundred and fifty dollars (\$250.00) per day for each and every day beyond the work performance period as specified in the Notice to Proceed. The total amount of daily charges will be deducted from any moneys due the Contractor, not as a penalty but as liquidated damages.

#### **REVEGETATION AND WARRANTY**

The seeding date shall be at the discretion of the contractor once an approved seedbed has been prepared. In all cases a permanent vegetative cover capable of supporting the post-mining land use must be established. A warranty period of one (1) year shall commence upon completion and payment of the revegetation item of the contract. No payment will be made for additional seeding necessary to comply with warranty requirements. The warranty period will be extended for one (1) year from the date of the last augmented seeding done by the contractor. The performance bond and labor and materials bond shall remain in effect throughout the warranty period. The Standards for Evaluating Vegetative Cover as presented in Title 38, CSR2, and Section 9 of the West Virginia Surface Mining Reclamation Regulations will apply.

Equipment for the retracking/scarification to eliminate rills and gullies shall be mobilized and utilized to produce slopes consistent with the regrading and top soiling bid item prior to warranty reseeding. No additional payment will be made by DEP for this warranty work.

Water utilized for hydro seeding shall be free of injurious or other toxic substances harmful to plant life. The source of water is subject to the approval of the DEP contact person.

#### **CONTRACT NON-COMPLIANCE**

If in the opinion of the Department of Environmental Protection the contract is not in compliance with any line item specification, that portion of the project shall cease until a compliance schedule and understanding is demonstrated in writing and accepted by the Director of Division of Land Restoration.

#### **CONTRACT DELETIONS**

Any line item, or any portion thereof, may be deleted when determined by the project contact person that such line item or portion thereof, is deemed unnecessary for the successful reclamation of this project. No claim for loss of anticipated profits will be considered.

#### **CANCELLATION**

The performance of work under contract may be terminated by the State in whole, or from time to time in part whenever the State shall determine that such termination is in the best interest of the State. Any such termination



PRO CONTRACTING, INC.  
PO BOX 2442  
CLARKSBURG, WV 26302

BUYER CB-23	PAGE 031	REQ. OR PO NO. DEP 14152
SPENDING UNIT WEST VIRGINIA DEPARTMENT OF ENVIRONMENTAL PROTECTION/SPECIAL RECLAMATION		

WV-36a            STATE OF WEST VIRGINIA  
REV. 5-1-08      PURCHASING CONTINUATION SHEET  
VENDOR:

---

shall be effected by delivery to the Contractor of a Notice of Termination specifying the extent to which performance of work under the Contract is terminated and the date upon which such termination becomes effective.

When contracts, or any portion thereof, are terminated before completion of all items of work in the Contract, payment will be made for the actual number of units or items of work completed and accepted at the contract unit price. No claim for loss of anticipated profits will be considered. Reimbursement for organization of the work, when not otherwise included in the Contract, and moving equipment to and from the job will be considered where the volume of work completed and accepted is too small to compensate the Contractor for these expenses under the contract unit prices, the intent being that an equitable settlement will be made with the Contractor.

Termination of the Contract or a portion thereof shall not relieve the Contractor of his responsibilities for the completed work, nor shall it relieve his surety of its obligation for and concerning any just claims arising out of the work performed. This contract may be cancelled in whole or in part in writing by the Director of Purchasing, without prejudice to any other right or remedy it may have, provided that the contractor is given not less than thirty (30) calendar days written notice, (delivered by certified mail, return receipt requested) of intent to terminate. This contract objective is to comply with the reclamation laws of this state and must be expedient to meet the time requirements for reclamation of revoked surface mine permits.

PRO CONTRACTING, INC  
P.O. BOX 2442  
CLARKSBURG, WV 26302

BUYER CB-23	PAGE 032	REQ. OR PO NO. DEP 14152
SPENDING UNIT WEST VIRGINIA DEPARTMENT OF ENVIRONMENTAL PROTECTION/SPECIAL RECLAMATION		

WV-36a            STATE OF WEST VIRGINIA  
REV. 5-1-08      PURCHASING CONTINUATION SHEET  
VENDOR:

---

**S**

Attn:

**A**  
Re: Notice to Proceed  
Permit Name: \_\_\_\_\_  
Permit No. \_\_\_\_\_  
Purchase Order No.: DEP

Dear :

**M**  
The purpose of this letter is to express our appreciation for your work in advance and to recognize a reclamation partnership project. The official starting date for the above mentioned purchase order is . The work performance period must be completed by . The contract life of one year is provided to accomplish all line items and to process all payments within that period.

**P**  
You must schedule a pre-construction conference on site within ten (10) days after receiving this notice to proceed. It is then mandatory that construction begins within ten (10) days of the pre-construction conference and continues diligently until completion of the project. Please contact this office to schedule the pre-construction conference. The foreman, superintendent, or on-the-ground supervisor must be in attendance at this conference.

Failure to comply with this notice to proceed will cause termination of the contract and forfeiture of your performance bond.

If you have any questions please feel free to contact this office.

**L**

Sincerely,

**E**

PRO CONTRACTING, INC.  
PO BOX 2442  
CLARKSBURG, WV 26302

BUYER CB-23	PAGE 033	REQ. OR PO NO. DEP 14152
SPENDING UNIT WEST VIRGINIA DEPARTMENT OF ENVIRONMENTAL PROTECTION/SPECIAL RECLAMATION		

WV-36a            STATE OF WEST VIRGINIA  
REV. 5-1-08      PURCHASING CONTINUATION SHEET  
VENDOR:

---

## General Requirements

### Project Construction Sign

#### Work Required

The work to be performed under this Section consists of providing all labor, material and equipment necessary to install a project sign as indicated on the detail included herein and as specified herein.

#### Materials

- (a) Paint. Paint for the project sign shall be one (1) coat Exterior-Grade Wood Primer- Sealer, and two (2) coats Exterior-Grade Enamel by Glidden or equivalent.
- (b) Wood. Sign face shall be ¾" X 4' X 8' Marine Exterior plywood and posts and cross braces shall be treated.
- (c) Hardware. All hardware shall be manufactured from good, commercial-quality material and be rust resistant such as galvanized coated.

#### Execution

- (a) Project Sign. The signboard shall be cut to the dimensions shown on the details herein. The sign shall be painted with one (1) coat of primer and two (2) coats of white enamel. All exterior cut edges shall be smooth sanded prior to painting. All edges shall be double primed. The letters, border and strips shall be painted as shown on the detail drawing.

The Contractor shall bolt the sign to posts and provide required cross bracing. The posts and sign shall be erected and posts set in gravel base, as shown on the drawings. One (1) sign is required and is to be located at the direction of WVDEP.

- (b) Payment. Payment for the work which shall include installation of the project sign shall be incidental to the lump sum bid item for "Mobilization/Demobilization"  
Note: No construction work shall commence prior to the project sign being installed.

**STATE OF WEST VIRGINIA**  
**DEPARTMENT OF ENVIRONMENTAL PROTECTION**

**Division of Land Restoration**  
**Office of Special Reclamation**

Project Cost: \$XXX,XXX.00  
 Funding provided by the Special Reclamation Coal Tax paid by WV Coal Mine Companies

Permit Name  
 Permit Number

Contractor: Joe Smith Contracting      Project Start Date: 01/01/01

Contractor: Joe Smith Contracting      Project Start Date: 01/01/01



Joe Manchin, III  
Governor



Randy C. Huffman,  
Cabinet Secretary



Ken Ellison,  
Director

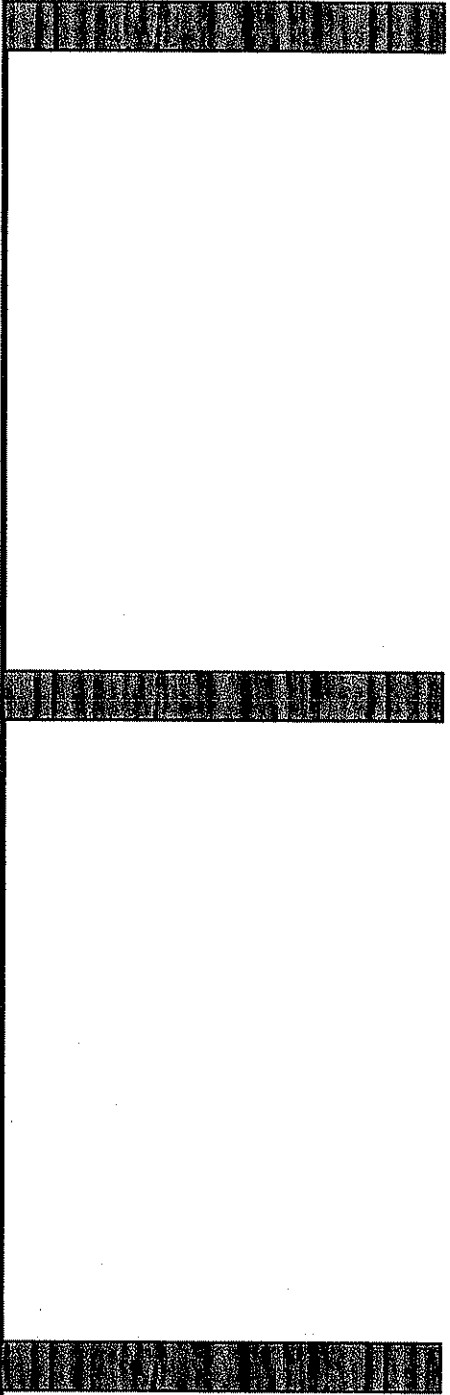

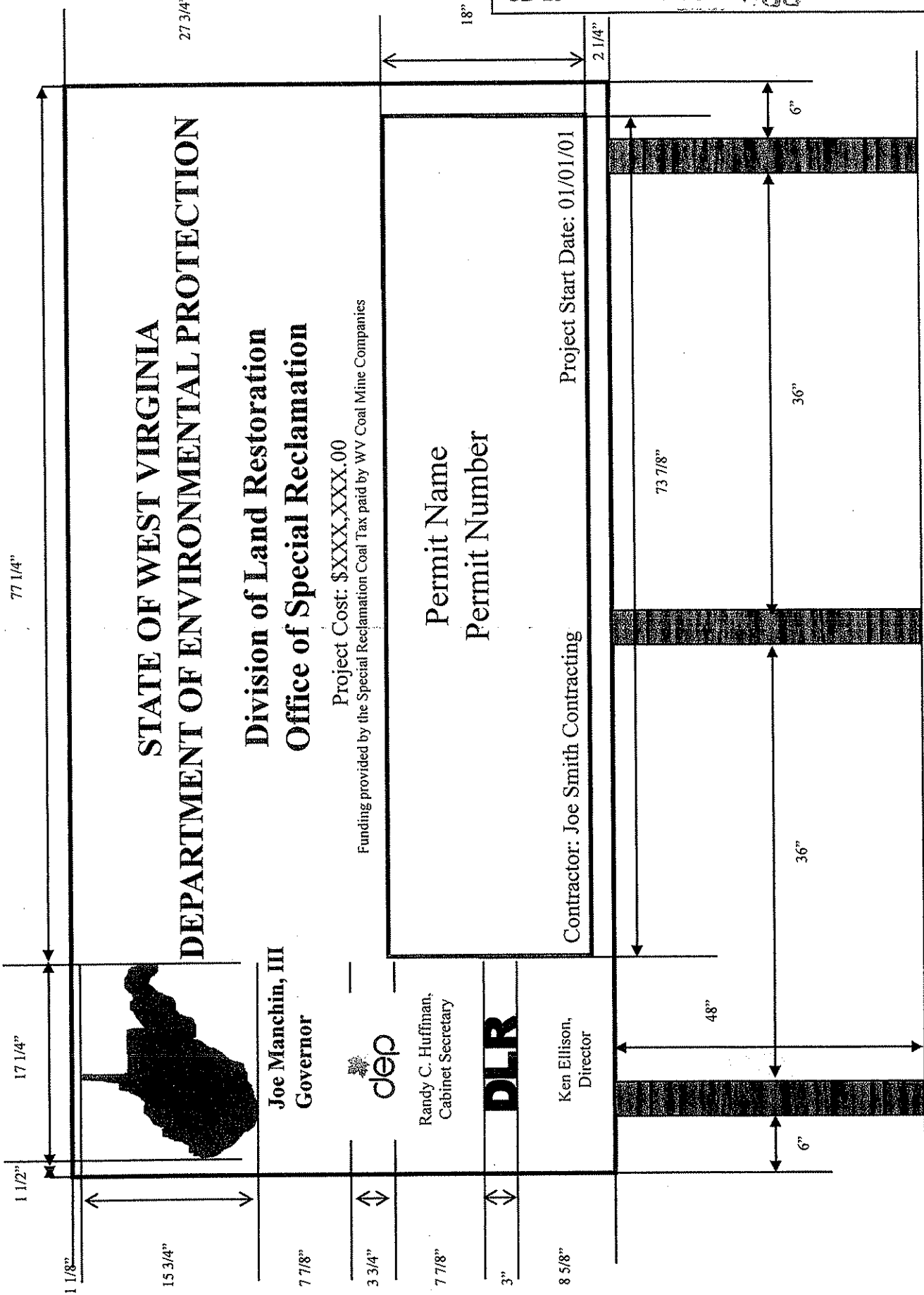

77 1/4"

17 1/4"

1 1/2"

1 1/8"

15 3/4"

27 3/4"

18"

2 1/4"

73 7/8"

36"

36"

48"

6"

Project Cost: \$XXXX,XXX.00  
Funding provided by the Special Reclamation Coal Tax paid by WV Coal Mine Companies

Permit Name  
Permit Number

Contractor: Joe Smith Contracting  
Project Start Date: 01/01/01

Joe Manchin, III  
Governor



Randy C. Huffman,  
Cabinet Secretary



Ken Ellison,  
Director

96"



STATE OF WEST VIRGINIA  
DEPARTMENT OF ENVIRONMENTAL PROTECTION

Division of Land Restoration  
Office of Special Reclamation

Joe Manchin, III  
Governor

Project Cost: \$XXX,XXX.00  
Funding provided by the Special Reclamation Coal Tax paid by WV Coal Mine Companies



Randy C. Huffman,  
Cabinet Secretary



Ken Ellison,  
Director

Permit Name  
Permit Number  
Contractor: Joe Smith Contracting  
Project Start Date: 01/01/01

81 3/8"

7 7/8"

9 3/8"

5 1/4"

48"

6" 2 1/4" 1 1/4" 2 1/4" 3 3/4" 2 3/4" 1 1/4" 2 1/4" 3 3/4" 1 1/4" 4 7/8" 2 1/4" 1 1/4" 2 1/4" 4 7/8" 1 1/4" 3 3/4"

**STATE OF WEST VIRGINIA**  
**DEPARTMENT OF ENVIRONMENTAL PROTECTION**

**Division of Land Restoration**  
**Office of Special Reclamation**

Project Cost: \$XXX,XXX.00  
 Funding provided by the Special Reclamation Coal Tax paid by WV Coal Mine Companies

Permit Name  
 Permit Number

Contractor: Joe Smith Contracting  
 Project Start Date: 01/01/01



Joe Manchin, III  
Governor



Randy C. Huffman,  
Cabinet Secretary



Ken Ellison,  
Director



**NOTES:**

- 1.) SIGN BOARD TO BE 3/4" x 4' x 8' MARINE PLYWOOD.
- 2.) SIGN BOARD COLOR IS WHITE AND LETTER COLORS ARE DARK GREEN.
- 3.) TREATED 2" x 4" CROSS BRACE LET INTO POSTS.
- 4.) MOUNT SIGN TO POSTS USING 3/8" x 5" GALVANIZED CARRIAGE BOLTS.
- 5.) USE 4" x 4" x 12' TREATED POSTS.
- 6.) LOCATION DETERMINED BY WVDEP.

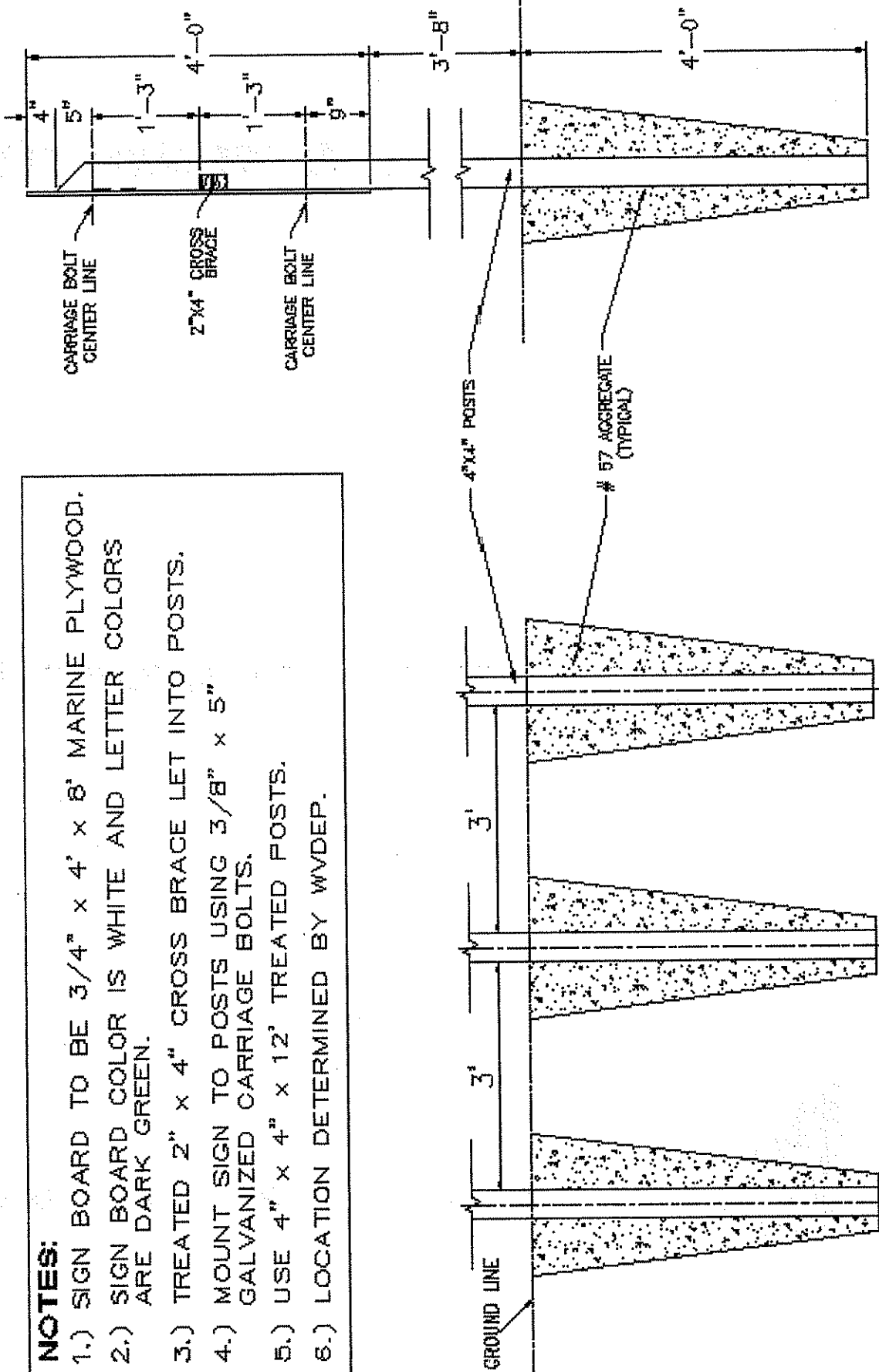

PROJECT SIGN  
NOT TO SCALE



S. KELLY - PERMIT# 51-78  
EXISTING CONDITIONS

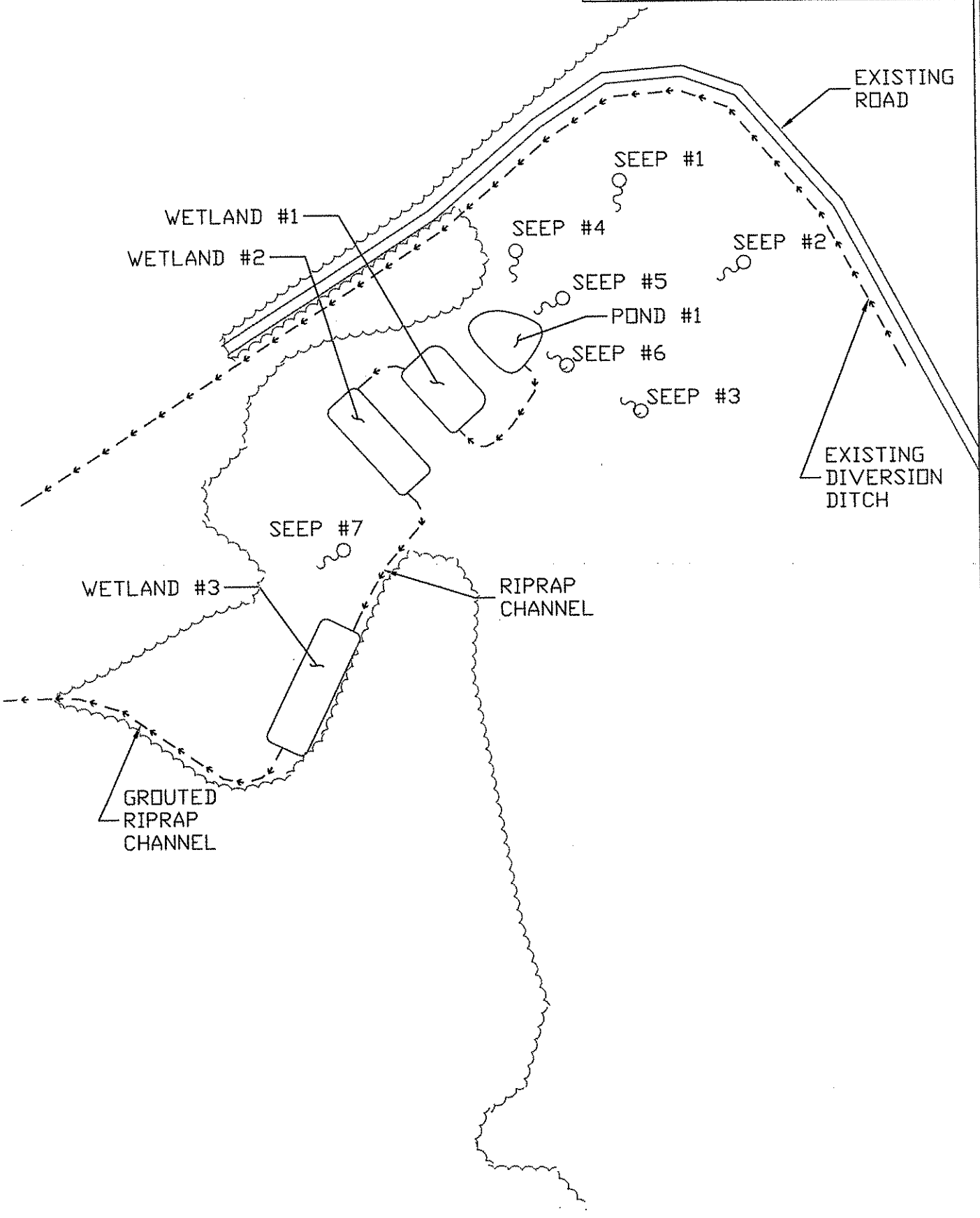

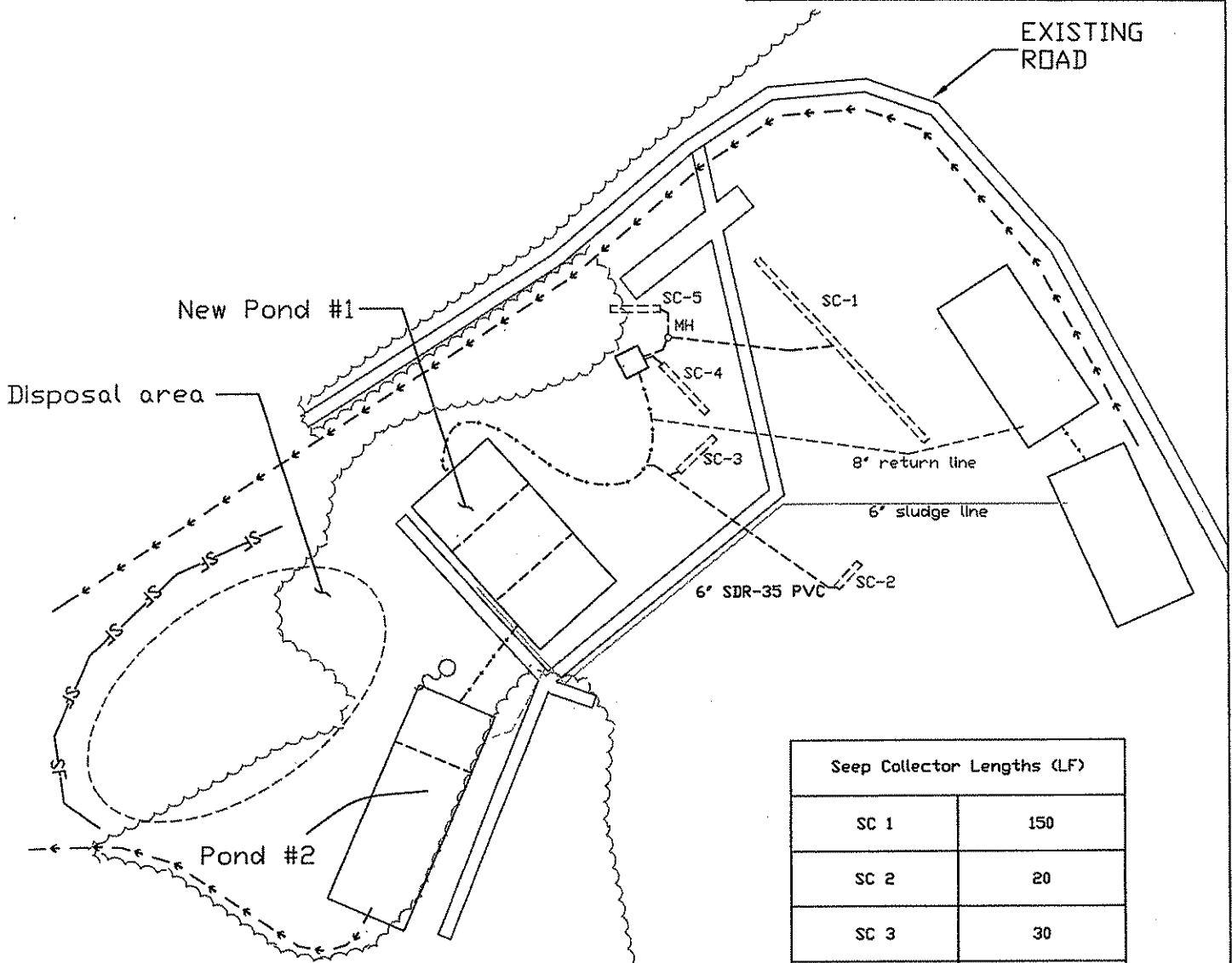

Seep Collector Lengths (LF)	
SC 1	150
SC 2	20
SC 3	30
SC 4	40
SC 5	30

NOTES:

1. Eliminate existing Pond 1
2. Install seep collectors (SC)
3. Install Manhole
4. Clean Wetlands
5. Expand Wetland 2.
6. Excavate wetlands 2 & 3 to settling pond depth consisting of 8ft water depth w/ 2ft freeboard.
7. Install grouted riprap ditches
8. Install dosing unit and silo.
9. Install piping to manhole
10. Construct sludge disposal cells
11. Install sludge pumping line.
12. Install emergency overflow line from sludge cells.
13. Install curtain baffles.
14. Install silt fence at low end of construction limits for sediment control

SPILL CONTAINMENT

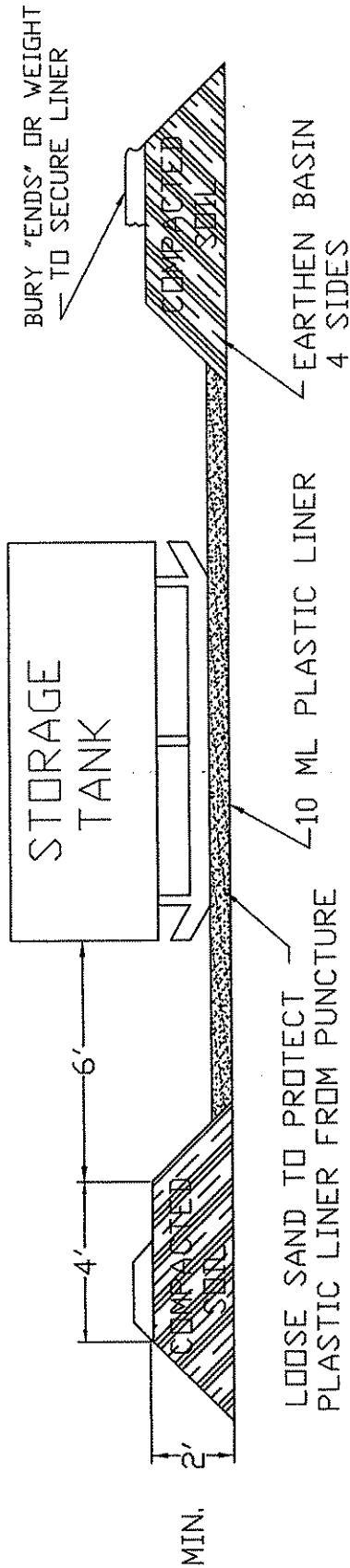

SELECTED HEIGHT OF EARTHEN BERM IS TO BE A TWO (2') FOOT MINIMUM OR ONE HUNDRED TEN PERCENT (110%) OF THE CAPACITY OF THE TANK(S) TOTAL VOLUME WITHIN THE BERM. A SIX (6") INCH FREEBOARD MUST BE INCLUDED.

NOTE: A TWO INCH (2") WATER REMOVAL DRAIN SHALL BE LOCATED AT THE LOWEST POINT IN THE BOTTOM OF THE CONTAINMENT VOLUME. IT SHALL CONNECT TO A NORMALLY CLOSED VALVE OUTSIDE THE DIKE. THE VALVE SHALL BE MANUALLY OPERATED AND PROTECTED FROM UNAUTHORIZED OPERATION. RAINWATER CONTAINED WITHIN THIS DIKE SHALL BE EXAMINED PRIOR TO RELEASE TO ENSURE THAT HARMFUL QUANTITIES OF FUELS AND LUBRICANTS ARE NOT DISCHARGED. ALTERNATE METHODS OF WATER REMOVAL WILL BE CONSIDERED FOR APPROVAL.

TANKS WITH SECONDARY CONTAINMENT MAY BE USED AS AN ALTERNATIVE.

NEW ACCESS ROAD

NEW ACCESS ROAD

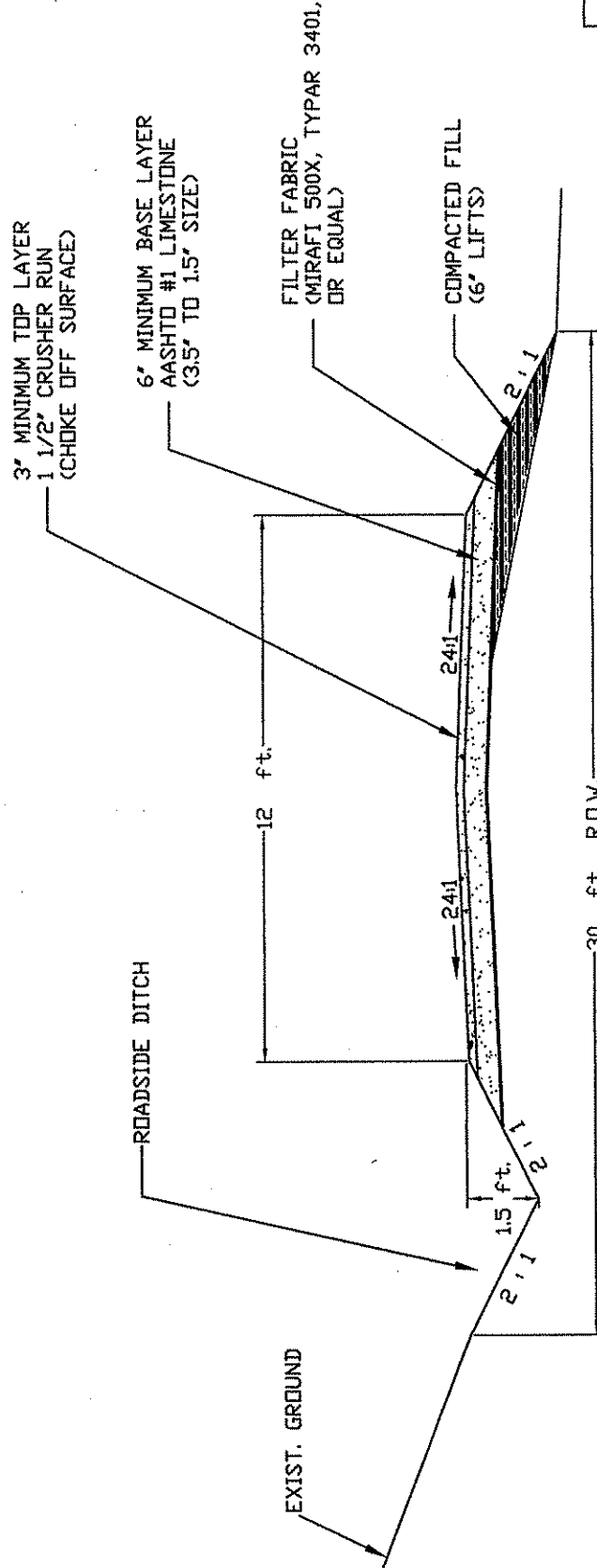

TYPICAL SECTION

NOTES: ANY TREES OR BRUSH WITHIN THE 30 FEET R.O.W. OF THE ROAD SHALL BE REMOVED.  
 ANY OVERHANGING TREE LIMBS IN THE R.O.W. AT A HEIGHT OF 15 FEET OR LESS SHALL BE REMOVED.

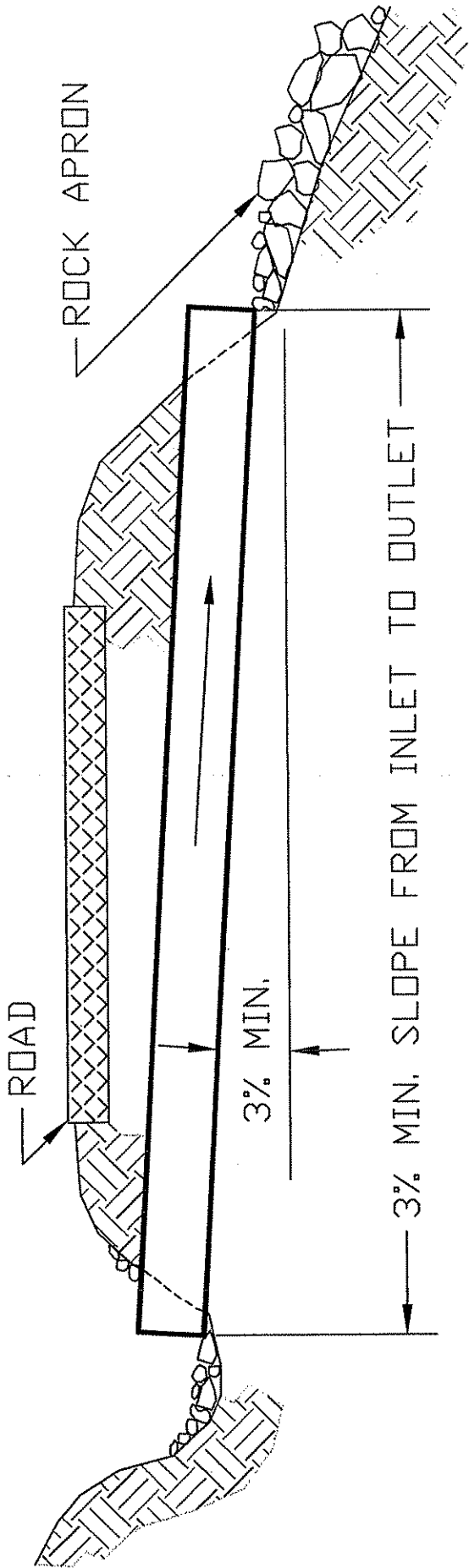

EARTHEN DIKE TO BE INSTALLED IN DITCH  
LINE BELOW CULVERT INLET

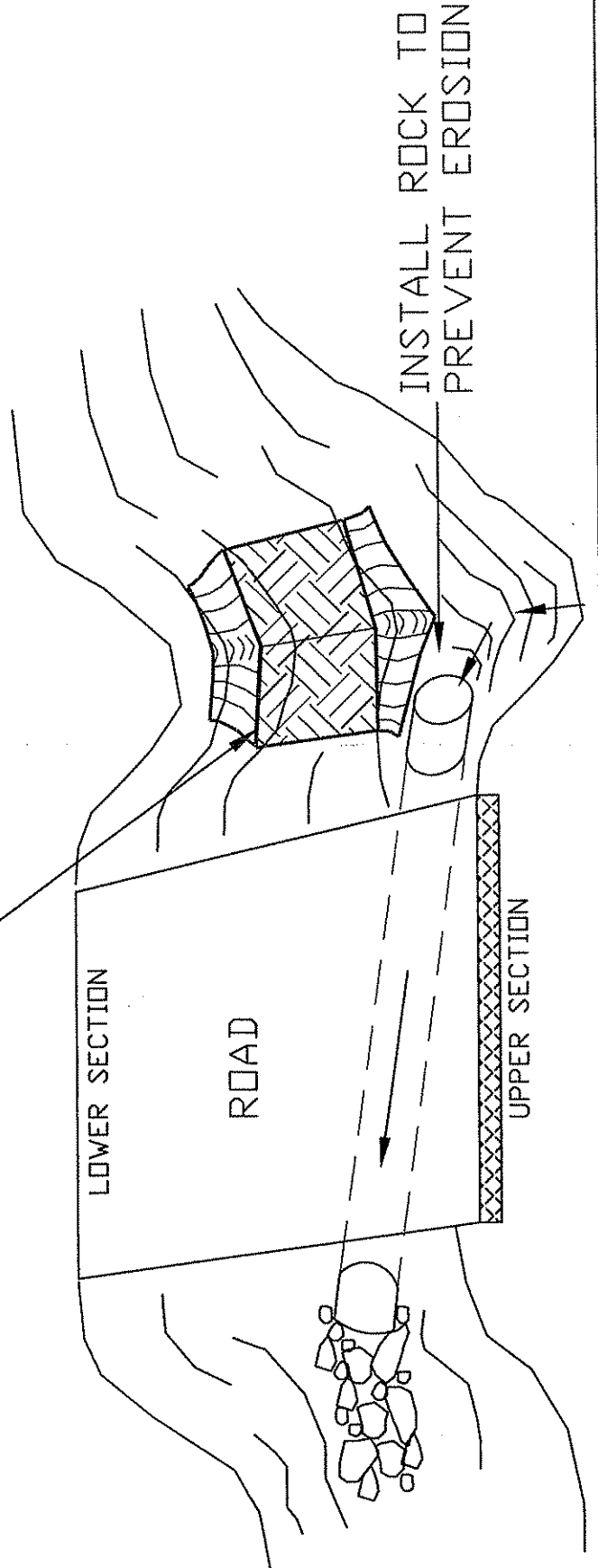

CULVERT INSTALLATION

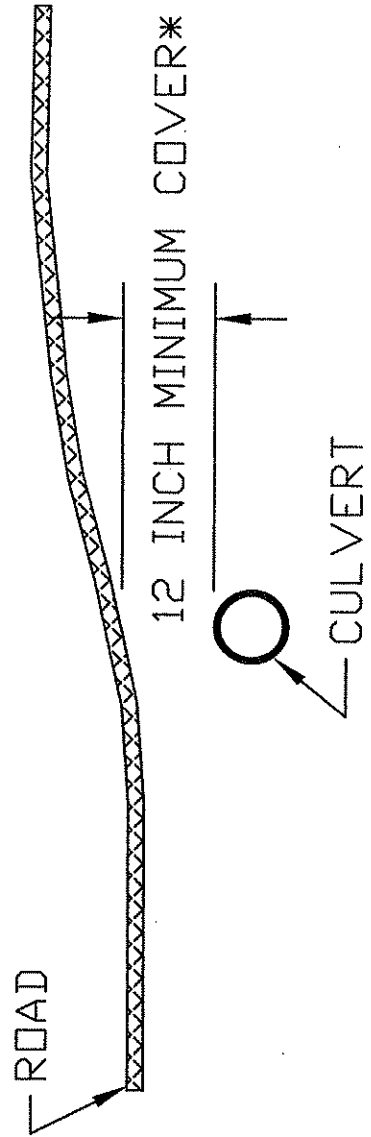
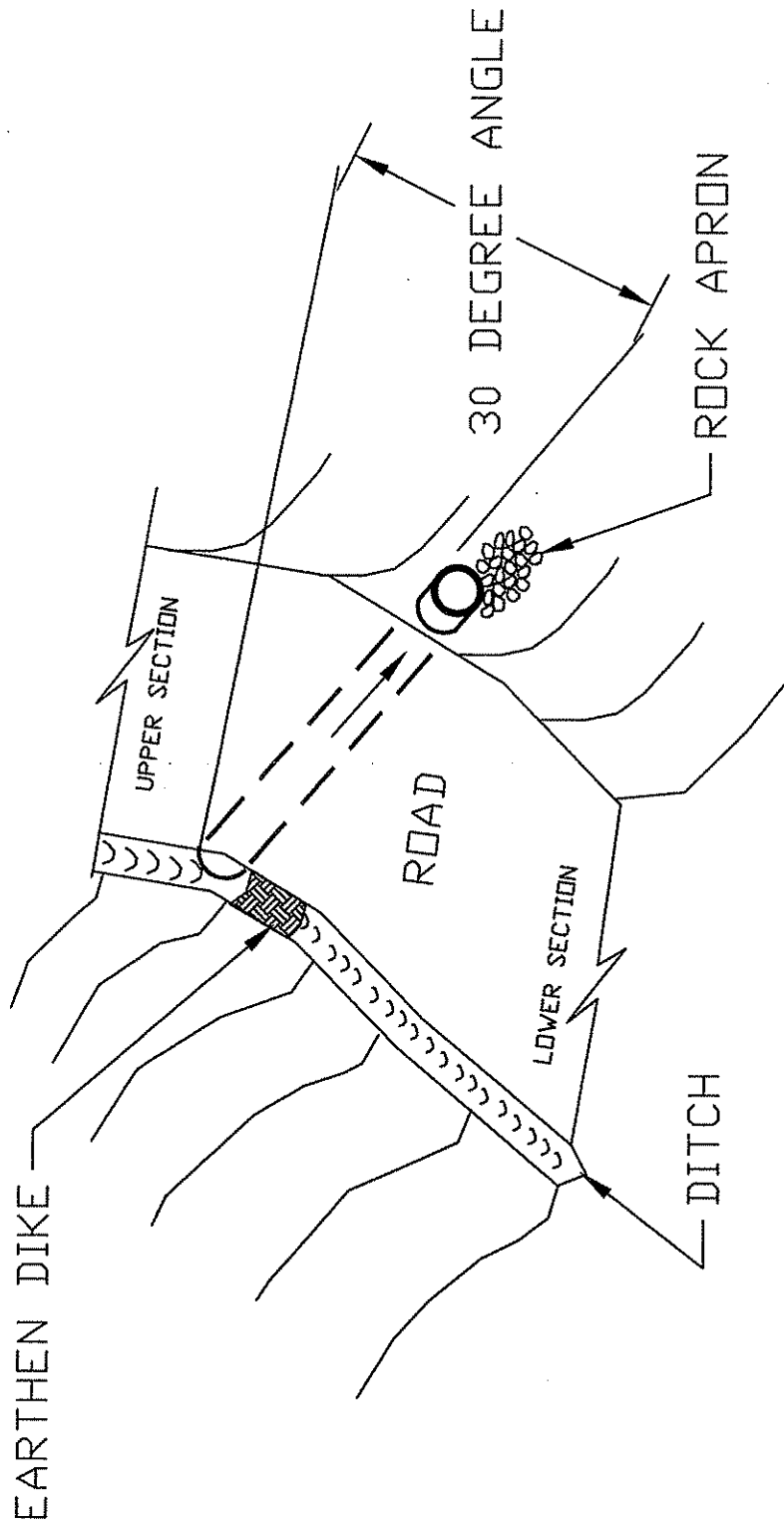

\*OR 1/2 CULVERT DIAMETER, WHICHEVER IS GREATER.

STRAW/HAY BALE DIKE

2 REBAR, STEEL PICKETS, OR  
2"X2" STAKERS PER BALE  
DRIVEN 1' MIN. INTO GROUND

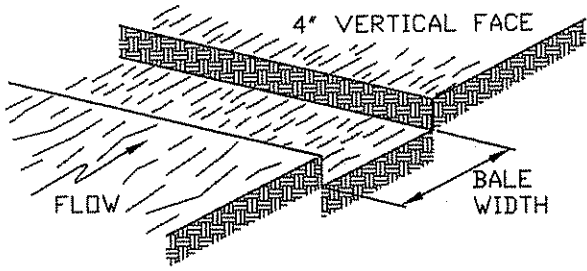

1. EXCAVATE THE TRENCH.

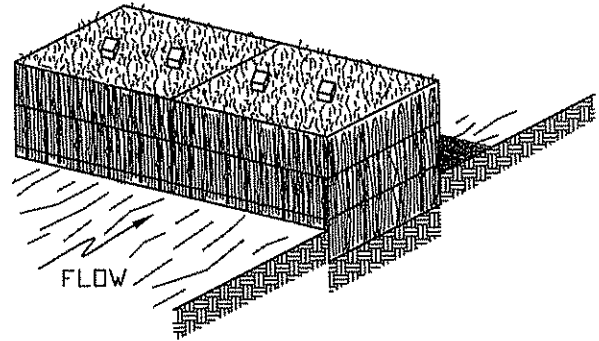

2. PLACE AND STAKE THE BALES.

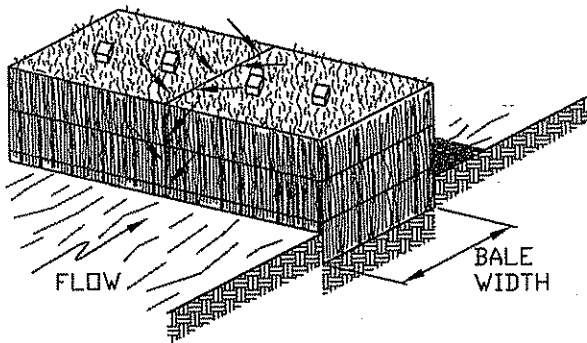

3. WEDGE LOOSE STRAW BETWEEN BALES.

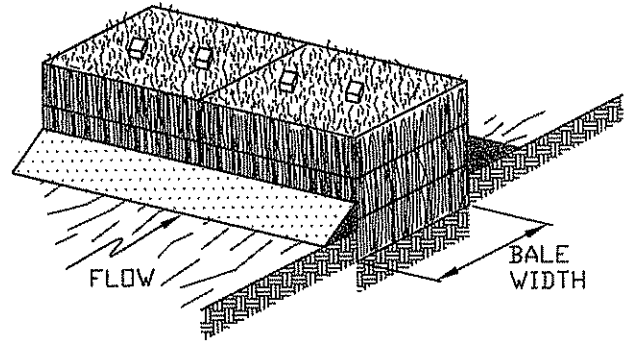

4. BACKFILL AND COMPACT THE EXCAVATED SOIL.

HAY OR STRAW BALE INSTALLATION SEQUENCE

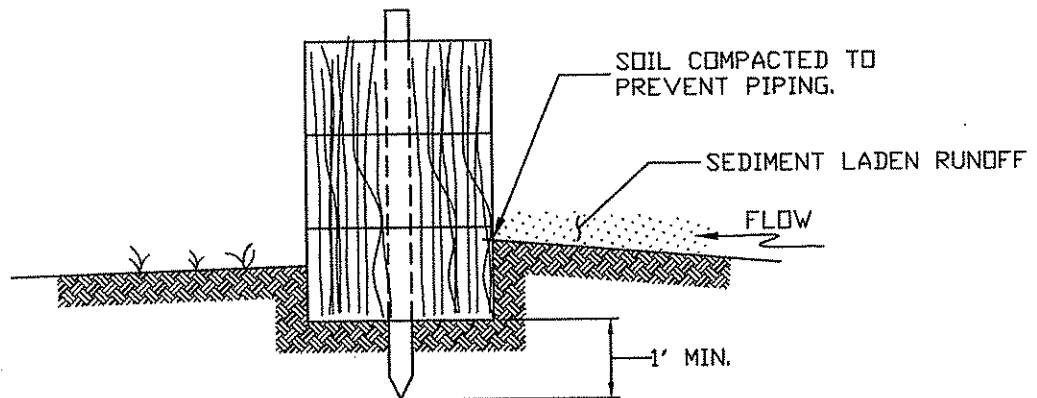

PROPERLY INSTALLED BALE

SILT FENCE INSTALLATION

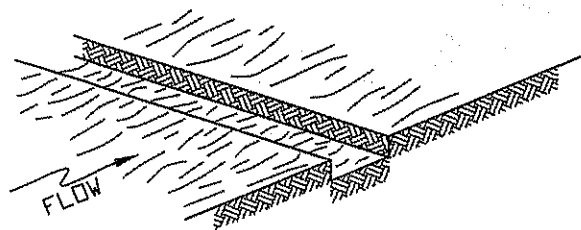

1. EXCAVATE 6" X 6" TRENCH

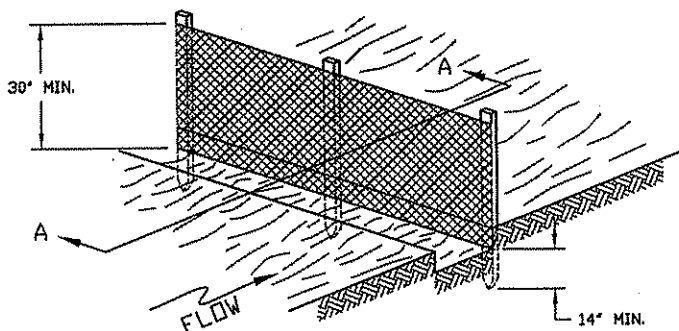

2. PLACE FENCE AT BACK EDGE OF TRENCH (FABRIC FACING DIRECTION OF FLOW)

3. DRIVE POST UNTIL FABRIC REACHES BOTTOM OF TRENCH

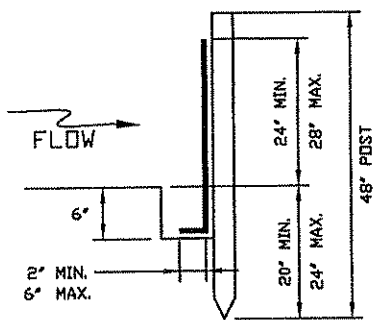

SECTION A-A

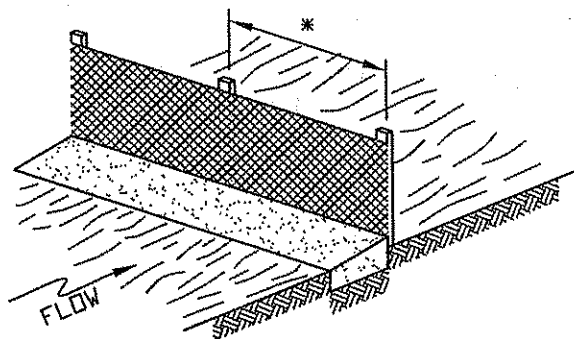

\* SEE SPECIFICATIONS FOR REQUIRED POST SPACING.

4. FILL TRENCH WITH EMBANKMENT & TAMP

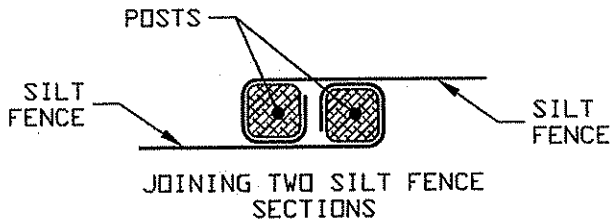

NOTE: WHEN MORE THAN ONE ROLL OF SILT FENCE IS USED, THE FENCE AT THE JUNCTION MUST BE PLACED SO THAT THE LAST POST OF THE FIRST RUN & THE FIRST POST OF THE SECOND RUN OVERLAP & ARE TIED TOGETHER.



# GROUTED TRAPEZOIDAL DITCH

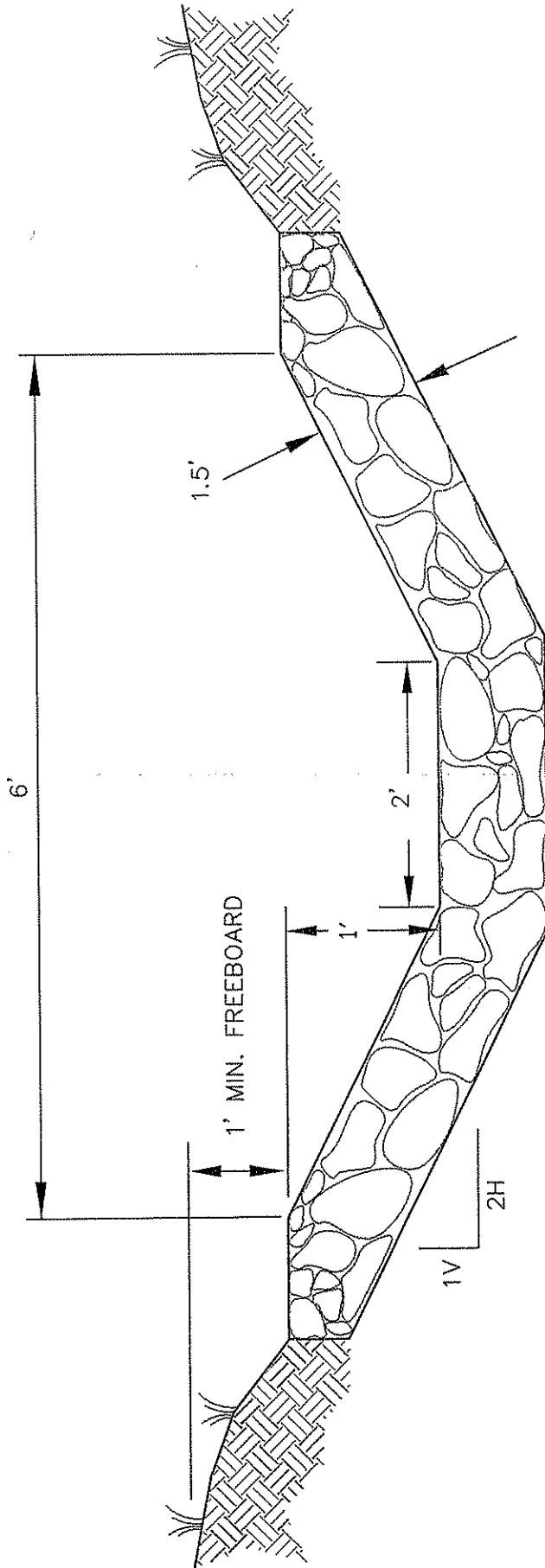

USE ONE PART OF TYPE II (SULPHATE RESISTANT) PORTLAND CEMENT AND 3 PARTS SAND, ADD WATER TO MAKE GROUT, THOROUGHLY WORK GROUT INTO VOID SPACES, AND BRUSH EXCESS GROUT OFF TOP OF RIPRAP STONES.

NOT TO SCALE

PAYMENT SHALL BE FOR ACTUAL LENGTH OF DITCH CONSTRUCTED.

R-5 LIMESTONE RIPRAP (STANDARD) UNLESS OTHERWISE NOTED, RIPRAP SHALL BE DURABLE ROCK PLACED IN A 1.5 FOOT BLANKET. TWENTY-FIVE (25%) OF THE ROCK WILL BE OF 18 INCHES OR LARGER, THE REMAINING SEVENTY-FIVE (75%) SHALL BE WELL GRADED MATERIAL (MINIMUM 3 INCHES TO MAXIMUM 15 INCHES) OF SUFFICIENT ROCK SMALL ENOUGH TO FILL THE VOIDS BETWEEN THE LARGER ROCK. SHALE SHALL NOT BE USED FOR RIPRAP. IF RIPRAP STABILITY IS QUESTIONABLE, DURABILITY SHALL BE DETERMINED BY THE SODIUM SULPHATE TEST ASTM C 88/AASHTO T 104-77.

BUYER  
CB-23

PAGE  
047

REQ. or P.D. No.  
DEP 14152

GROUTED RIPRAP DITCH

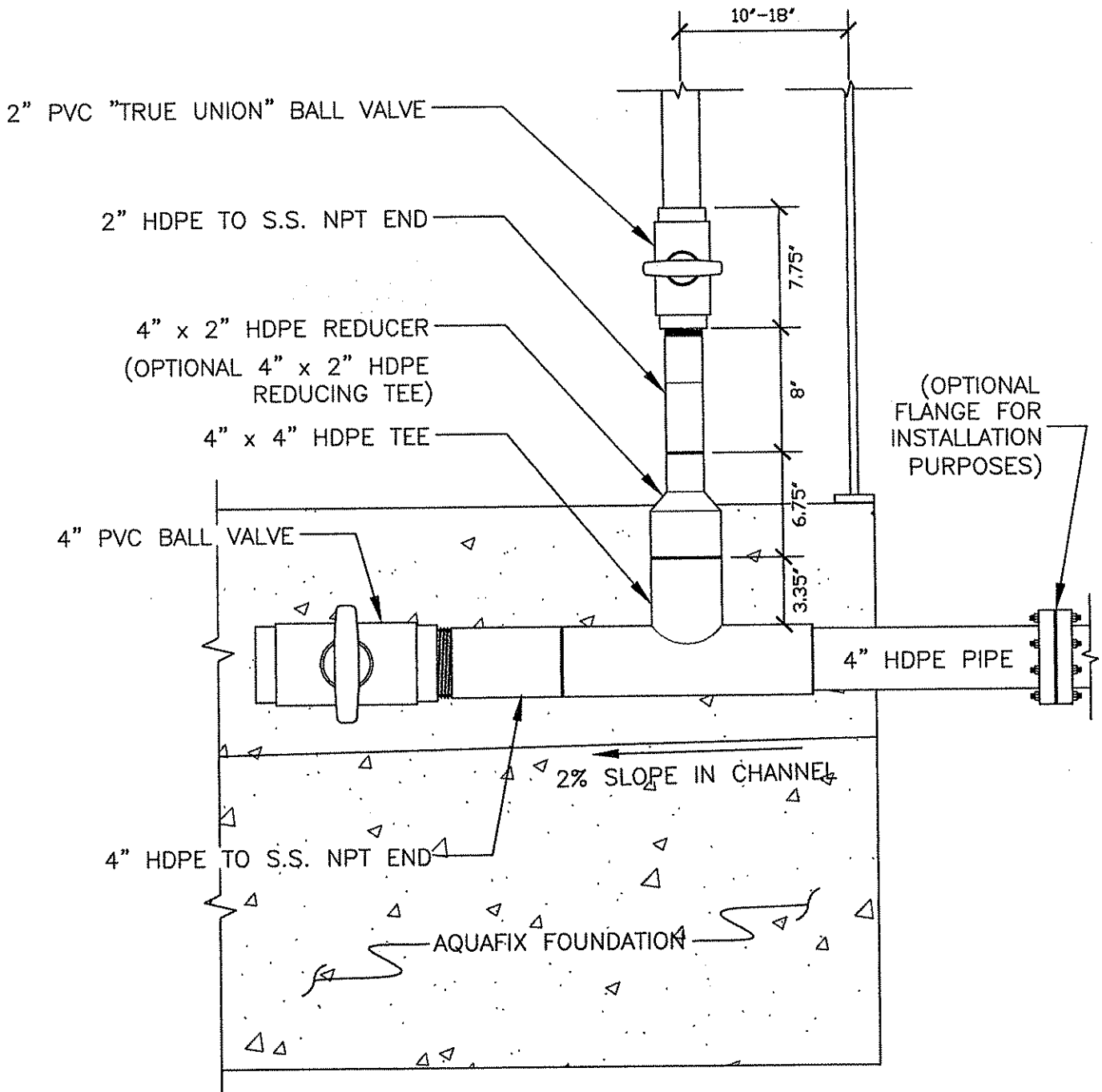

NOT TO SCALE

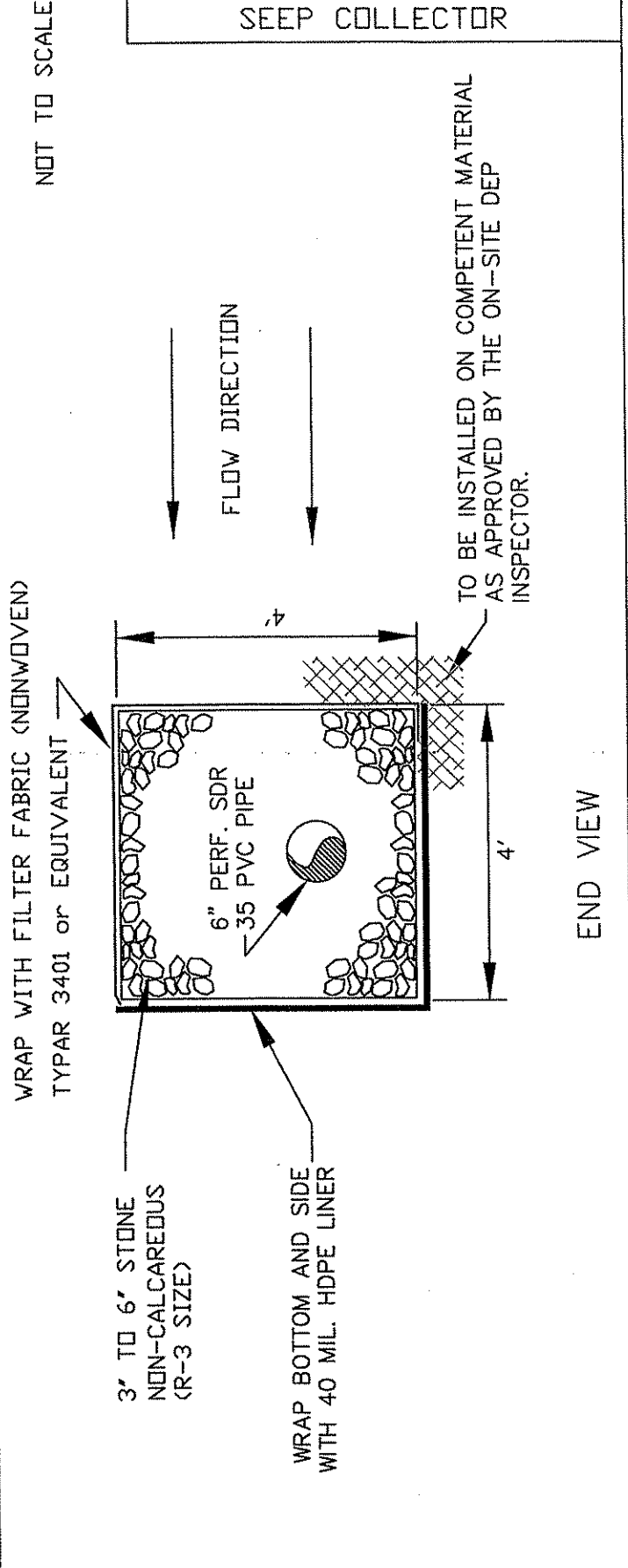
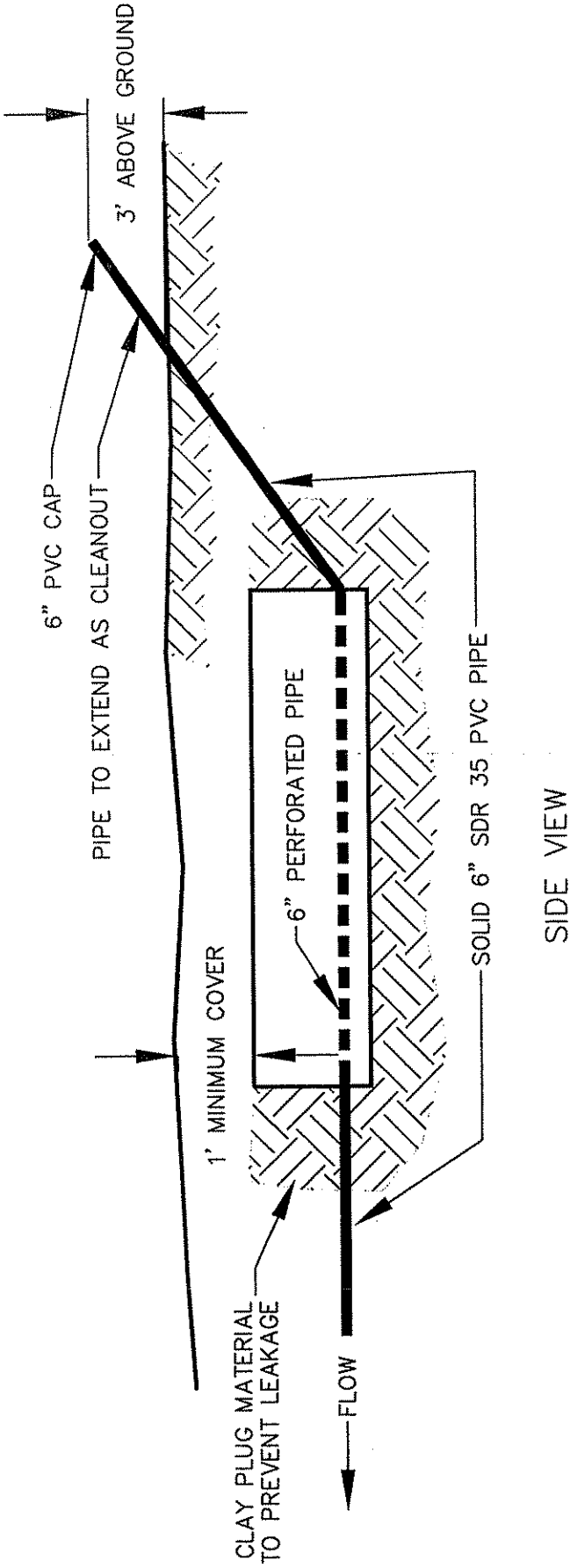

SC 1

MH

SC 5 0.0'

SC 4

Bldg.

SC 2

SC 3

Pond 1

-0.39'

-1.39'

-8.51

-9.39

-9.64

-13.49

-20.39

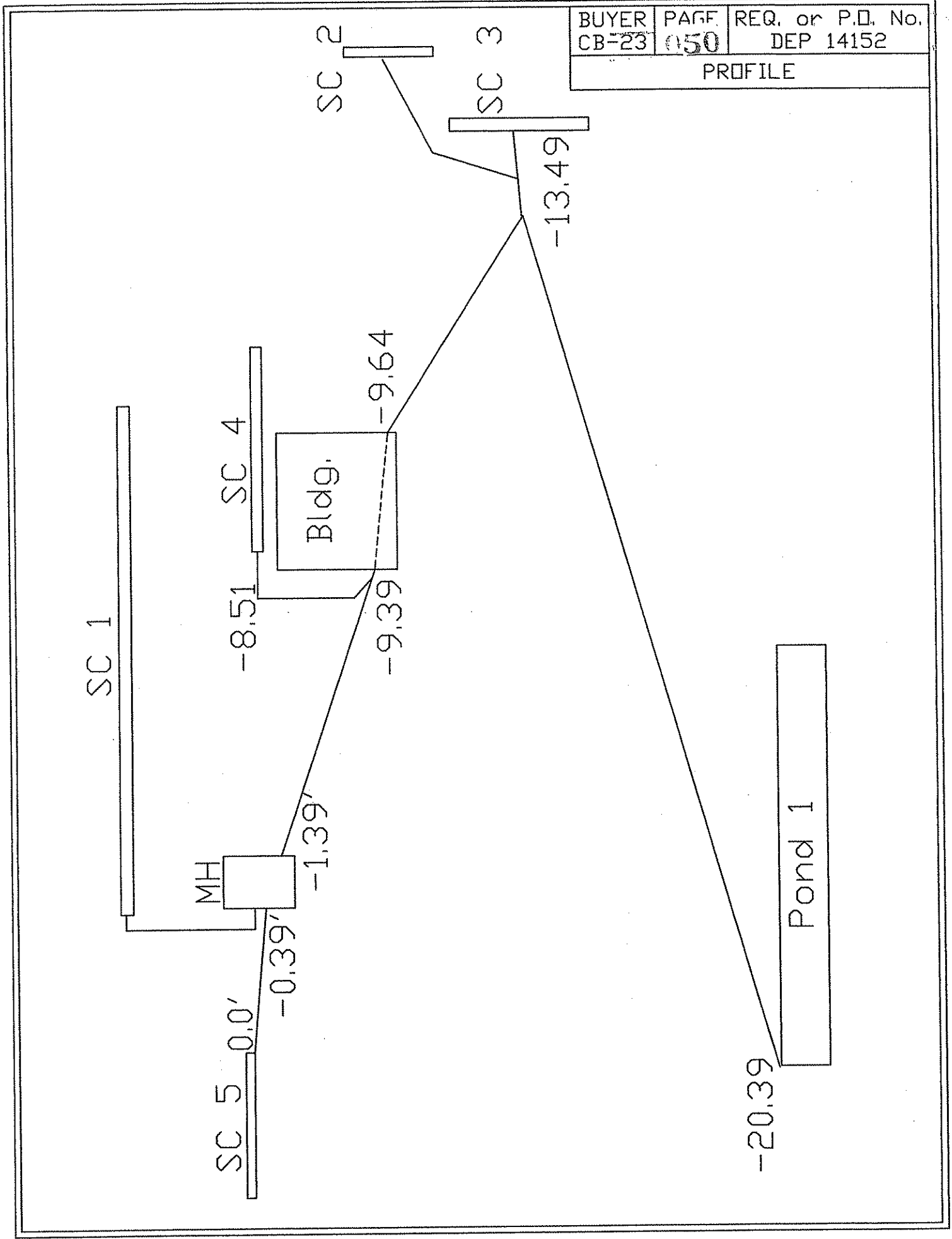

MANHOLE

**NOTES**  
 Manhole steps shall be placed into plastic concrete wall during manufacture or mortared into holes after the concrete has set.  
 Sidewall sections may be used in any combination to produce a manhole of desired depth, except the tapered top section shall be retained as shown.  
 Lifting hole in the tapered top section and the circumferential notches in the manhole cover are for handling purposes only.  
 Drawing shows pipe entering and leaving manhole in a straight line. However, the pipes may enter or leave at any angle or place as called for or shown on the plans.

Pipe at elevations other than shown may be joined to the manhole by cutting a hole the size of the connecting pipe in the manhole, inserting the pipe the thickness of the manhole shell and closing all openings around the connecting pipe with joint mortar.  
 Minimum height of bench wall above flow line of pipe is 25% of the diameter of the pipes.  
 The bearing area of the frame and cover shall be so fitted and finished as to provide a firm and even seat for the entire cover in the frame.  
 No projections shall exist on bearing areas of wither casting, and the cover shall seat in its frame without rocking.

Pipe invert shall be held at the minimal slope from the seep collector to the manhole.  
 The 6" SDR-35 invert will be held 6" above the 4" pipe in the manhole bottom.  
 The 4" pipe will be held at the treatment building finished floor.  
 Two six inch pipes from seep collectors #1 & #5 to the manhole.  
 Two outlet pipes: one 4 inch HDPE pipe to be used as the drive line to the dosing unit. The second pipe shall be a 6 inch SDR-35 PVC pipe to the concrete channel.

The invert of the 6 inch outlet pipe shall be two inches higher than the top of the 4 inch drive line.

2-6 inch inlet pipes  
 6 inch outlet pipe

4 inch drive line

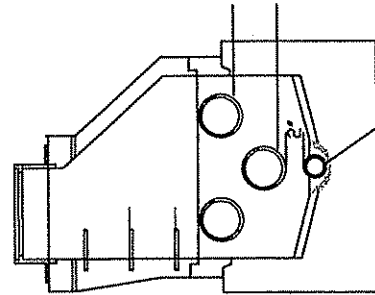
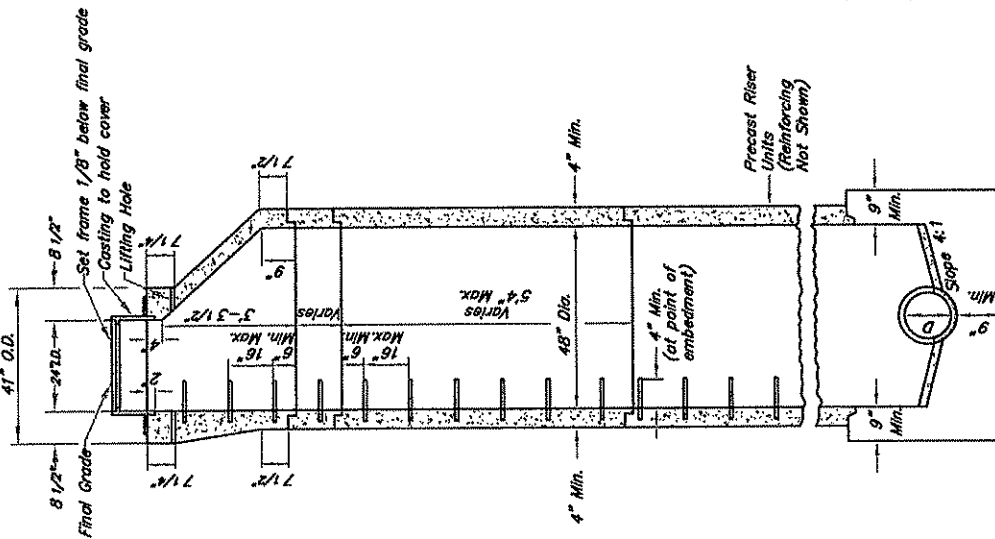

STANDARD DETAIL  
 TYPE A MANHOLE  
 Pre-Cast

# PIPE PERFORATION DETAILS

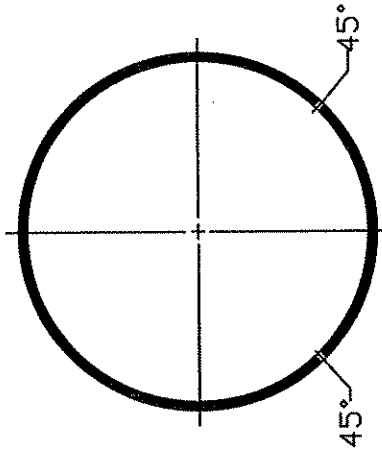

## 2, 4, & 6 INCH DIAMETER PIPE PERFORATIONS

HOLE SPACING SHALL BE 1/2 INCH DIAMETER FOR 2 & 4 INCH PIPE. USE 1 INCH DIAMETER HOLES FOR 6 INCH PIPE.

HOLE SPACING SHALL BE 4 INCHES ON CENTER ALONG THE LENGTH OF PIPE WITHIN SEEP COLLECTOR.

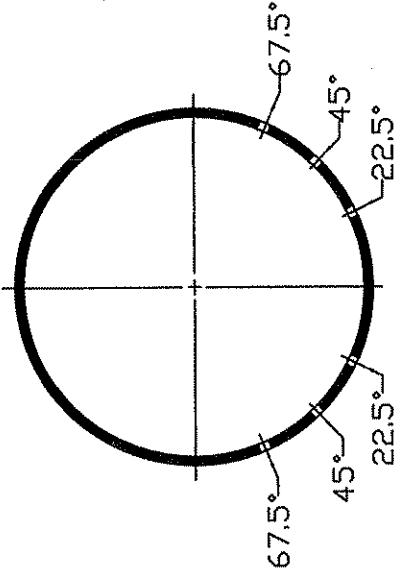

## 12 INCH DIAMETER PIPE PERFORATIONS

HOLE SPACING SHALL BE 6 INCHES ON CENTER ALONG THE LENGTH OF PIPE WITHIN SEEP COLLECTOR.

HOLE SPACING SHALL BE 6 INCHES ON CENTER ALONG THE LENGTH OF PIPE WITHIN SEEP COLLECTOR.

# ANIMAL GUARD DETAILS

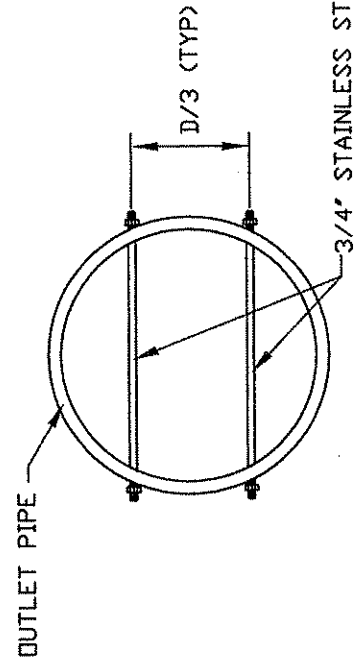

## PIPE PERFORATION & ANIMAL GUARD DETAILS

5/16" STAINLESS STEEL  
WIRE CABLE IN SEAM

1/2" GROMMETS

LOOP CHAIN  
BOLT IN PLACE  
AT SEAM ON  
EACH END (TYP)  
OR ATTACH  
SHACKLE WITH  
REINFORCING  
ALUMINUM  
PLATES

3"x4"x24"  
STYROFOAM

3"x4"x24"  
STYROFOAM

3"x4"x24"  
STYROFOAM

3"  
6"

CUT LINE  
FOLD LINE  
SPACING  
DETERMINED  
BY DEP

2 VINYL COATED POLYESTER  
17 OZ./SQ.YD. TOTAL WEIGHT

4'

HOT SEAM SEAL

1/2" POLYPROPYLENE  
ROPE SEAM IN ENDS

1/4" OR LARGER LINK CHAIN FOR WEIGHT

NOTE: THE CABLE MUST EXTEND 10 FEET PAST THE BAFFLE MATERIAL ON EACH END.  
THE OPENINGS SHALL BE CUT IN THE CURTAINS ON-SITE AT THE DIRECTION OF THE  
ON-SITE REPRESENTATIVE.

FOUNDATION DETAILS

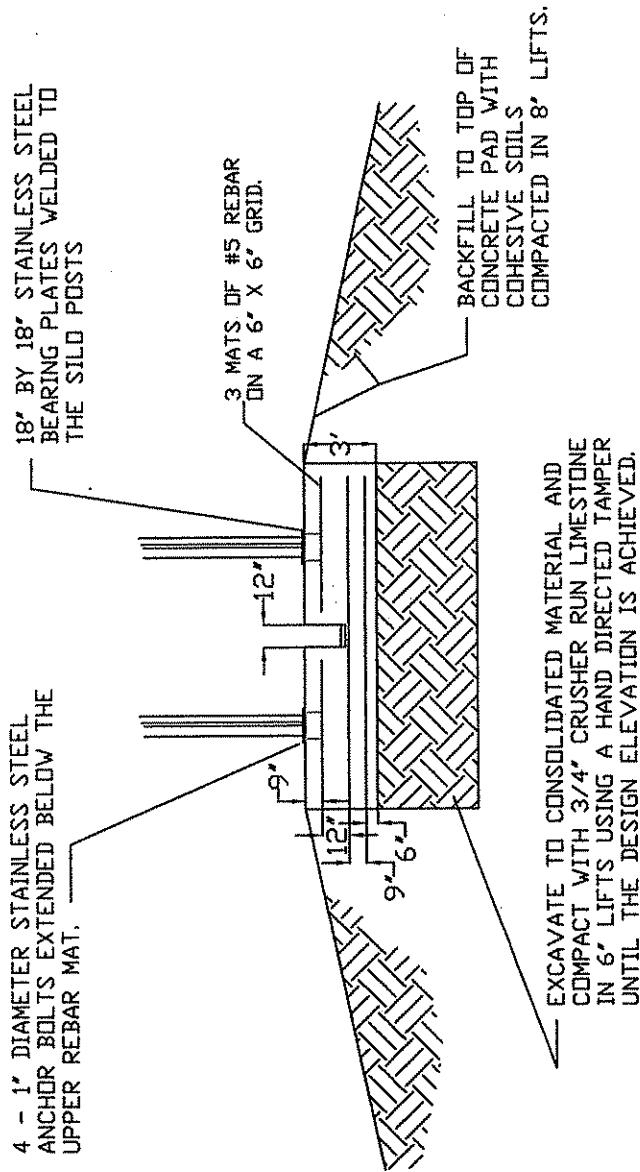

CROSS -SECTION B-B'

MOUNTING PLATE DETAILS

ANCHOR BOLTS ARE SPACED 15' APART MEASURED FROM CENTER TO CENTER.

STAINLESS STEEL PLATES ARE 18" BY 18" BY 1" THICK

HOLES ARE 1 1/8" IN DIAMETER.

ANCHOR BOLT SPACING TEMPLATE TO BE PROVIDED BY LIME SILO MANUFACTURER.

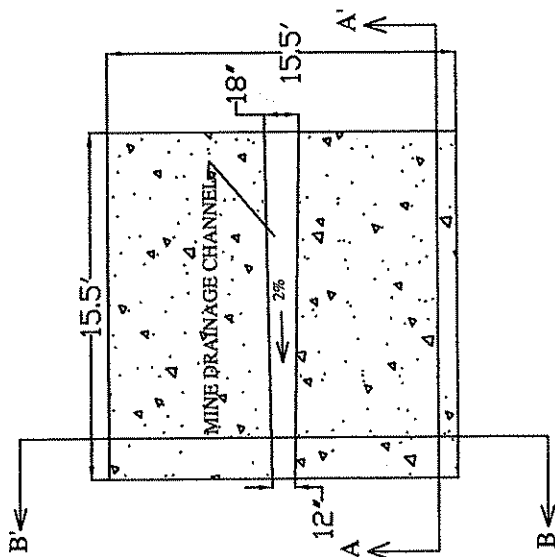

PLAN VIEW

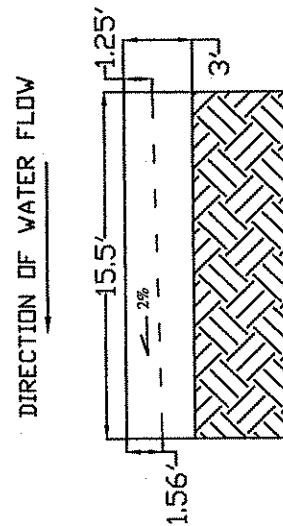

CROSS -SECTION A-A'



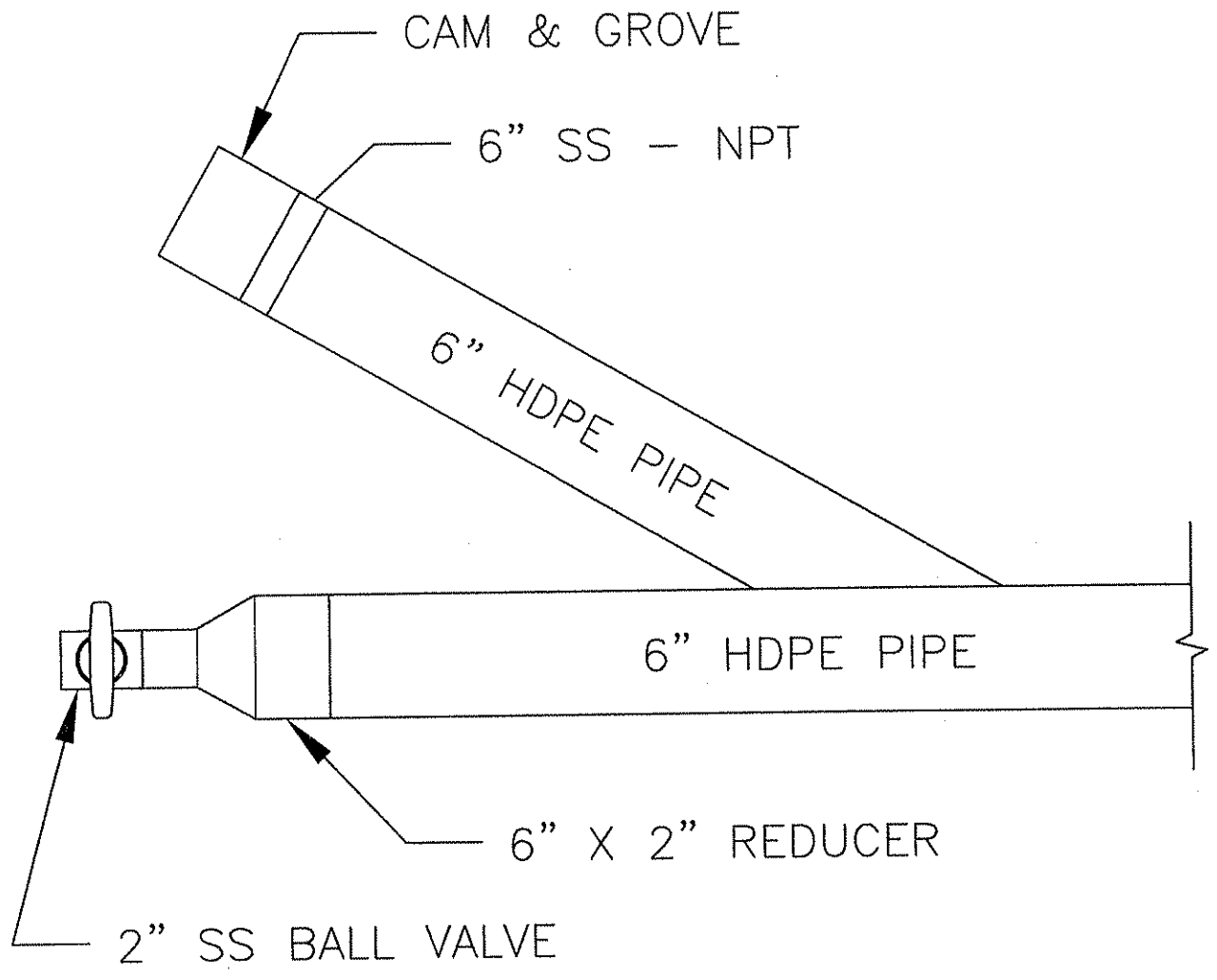

TRUCK TURN-AROUND

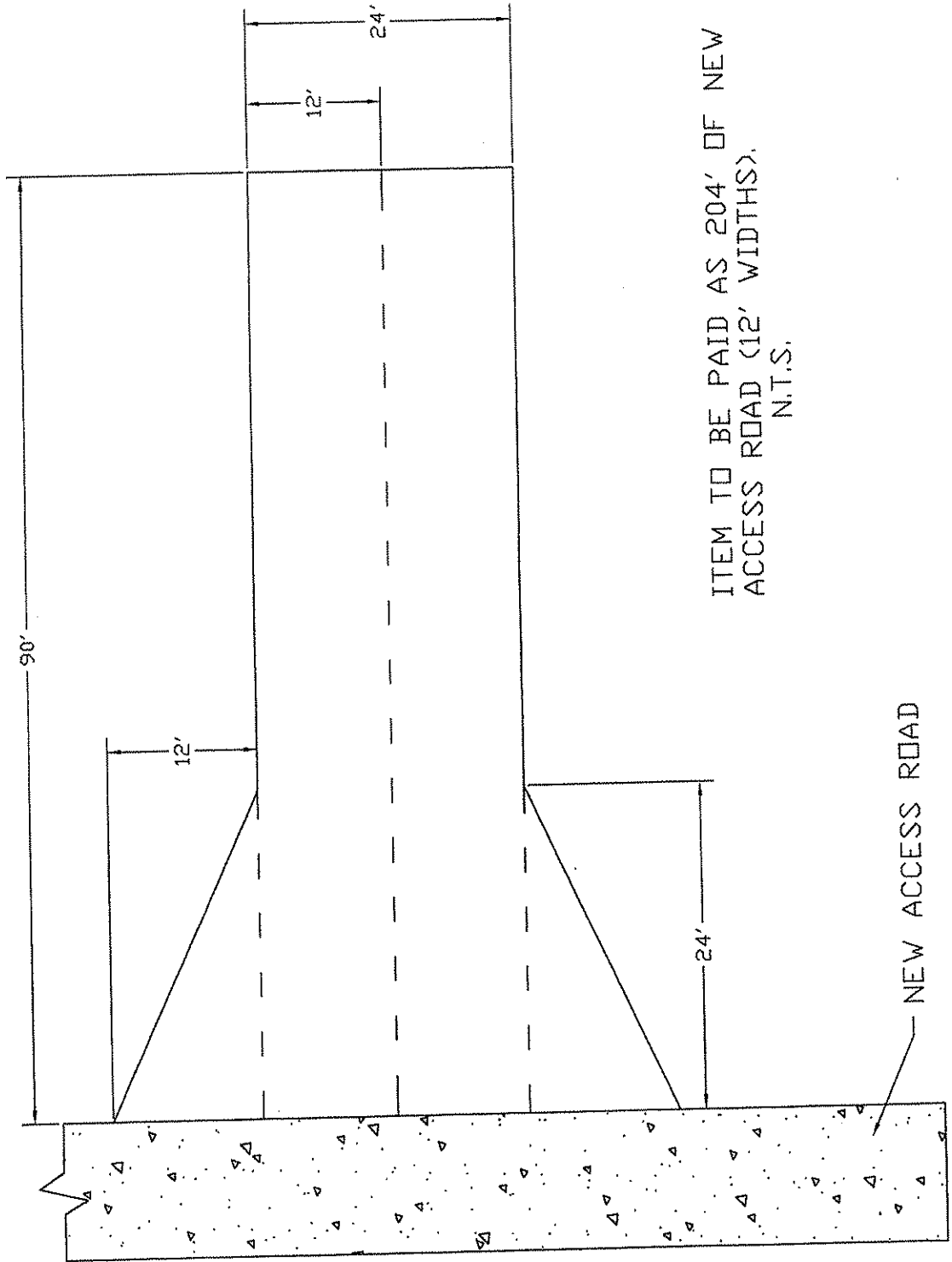

ITEM TO BE PAID AS 204' OF NEW  
ACCESS ROAD (12' WIDTHS),  
N.T.S.

NEW ACCESS ROAD

**BID BOND**

KNOW ALL MEN BY THESE PRESENTS, That we, the undersigned, Pro Contracting, Inc.  
of P. O. Box 2442, Clarksburg, WV 26302, as Principal, and Travelers Casualty and Surety Company  
of America of 1 Tower Sq., 5PB, Hartford, CT, a corporation organized and existing under the laws of the State of  
Connecticut with its principal office in the City of Hartford, as Surety, are held and firmly bound unto the State  
of West Virginia, as Obligee, in the penal sum of Five Percent of the total amount bid (\$ 5%) for the payment of which,  
well and truly to be made, we jointly and severally bind ourselves, our heirs, administrators, executors, successors and assigns.

The Condition of the above obligation is such that whereas the Principal has submitted to the Purchasing Section of the  
Department of Administration a certain bid or proposal, attached hereto and made a part hereof, to enter into a contract in writing for  
**DEP14152: Reclamation: Water Treatment**  
**Little Falls, WV - Monongalia County**

**NOW THEREFORE,**

(a) If said bid shall be rejected, or  
(b) If said bid shall be accepted and the Principal shall enter into a contract in accordance with the bid or proposal attached  
hereto and shall furnish any other bonds and insurance required by the bid or proposal, and shall in all other respects perform the  
agreement created by the acceptance of said bid, then this obligation shall be null and void, otherwise this obligation shall remain in full  
force and effect. It is expressly understood and agreed that the liability of the Surety for any and all claims hereunder shall, in no event,  
exceed the penal amount of this obligation as herein stated.

The Surety, for the value received, hereby stipulates and agrees that the obligations of said Surety and its bond shall be in no  
way impaired or affected by any extension of the time within which the Obligee may accept such bid, and said Surety does hereby  
waive notice of any such extension.

IN WITNESS WHEREOF, Principal and Surety have hereunto set their hands and seals, and such of them as are corporations  
have caused their corporate seals to be affixed hereunto and these presents to be signed by their proper officers, this  
18th day of February, 20 09.

Principal Corporate Seal

Pro Contracting, Inc.

(Name of Principal)

By [Signature]

(Must be President or  
Vice President)

President

(Title)

Surety Corporate Seal

Travelers Casualty and Surety Company of America

(Name of Surety)

[Signature]

Attorney-in-Fact

**IMPORTANT – Surety executing bonds must be licensed in West Virginia to transact surety insurance. Raised corporate seals  
must be affixed, a power of attorney must be attached.**



POWER OF ATTORNEY

Farmington Casualty Company
Fidelity and Guaranty Insurance Company
Fidelity and Guaranty Insurance Underwriters, Inc.
Seaboard Surety Company
St. Paul Fire and Marine Insurance Company

St. Paul Guardian Insurance Company
St. Paul Mercury Insurance Company
Travelers Casualty and Surety Company
Travelers Casualty and Surety Company of America
United States Fidelity and Guaranty Company

Attorney-In Fact No. 218346

Certificate No. 002462237

KNOW ALL MEN BY THESE PRESENTS: That Seaboard Surety Company is a corporation duly organized under the laws of the State of New York, that St. Paul Fire and Marine Insurance Company, St. Paul Guardian Insurance Company and St. Paul Mercury Insurance Company are corporations duly organized under the laws of the State of Minnesota, that Farmington Casualty Company, Travelers Casualty and Surety Company, and Travelers Casualty and Surety Company of America are corporations duly organized under the laws of the State of Connecticut, that United States Fidelity and Guaranty Company is a corporation duly organized under the laws of the State of Maryland, that Fidelity and Guaranty Insurance Company is a corporation duly organized under the laws of the State of Iowa, and that Fidelity and Guaranty Insurance Underwriters, Inc. is a corporation duly organized under the laws of the State of Wisconsin (herein collectively called the "Companies"), and that the Companies do hereby make, constitute and appoint

C. David Thomas, Richard L. Higginbotham, Bunnie Marie Perrine, Jeffery O'Dell, and Robin Hubbard-Sherrod

of the City of Charleston, State of West Virginia, their true and lawful Attorney(s)-in-Fact, each in their separate capacity if more than one is named above, to sign, execute, seal and acknowledge any and all bonds, recognizances, conditional undertakings and other writings obligatory in the nature thereof on behalf of the Companies in their business of guaranteeing the fidelity of persons, guaranteeing the performance of contracts and executing or guaranteeing bonds and undertakings required or permitted in any actions or proceedings allowed by law.

IN WITNESS WHEREOF, the Companies have caused this instrument to be signed and their corporate seals to be hereto affixed, this 23rd day of June, 2008

Farmington Casualty Company
Fidelity and Guaranty Insurance Company
Fidelity and Guaranty Insurance Underwriters, Inc.
Seaboard Surety Company
St. Paul Fire and Marine Insurance Company

St. Paul Guardian Insurance Company
St. Paul Mercury Insurance Company
Travelers Casualty and Surety Company
Travelers Casualty and Surety Company of America
United States Fidelity and Guaranty Company



State of Connecticut
City of Hartford ss.

By: [Signature]
George W. Thompson, Senior Vice President

On this the 23rd day of June, 2008, before me personally appeared George W. Thompson, who acknowledged himself to be the Senior Vice President of Farmington Casualty Company, Fidelity and Guaranty Insurance Company, Fidelity and Guaranty Insurance Underwriters, Inc., Seaboard Surety Company, St. Paul Fire and Marine Insurance Company, St. Paul Guardian Insurance Company, St. Paul Mercury Insurance Company, Travelers Casualty and Surety Company, Travelers Casualty and Surety Company of America, and United States Fidelity and Guaranty Company, and that he, as such, being authorized so to do, executed the foregoing instrument for the purposes therein contained by signing on behalf of the corporations by himself as a duly authorized officer.

In Witness Whereof, I hereunto set my hand and official seal. My Commission expires the 30th day of June, 2011.



[Signature]
Marie C. Tetreault, Notary Public

This Power of Attorney is granted under and by the authority of the following resolutions adopted by the Boards of Directors of Farmington Casualty Company, Fidelity and Guaranty Insurance Company, Fidelity and Guaranty Insurance Underwriters, Inc., Seaboard Surety Company, St. Paul Fire and Marine Insurance Company, St. Paul Guardian Insurance Company, St. Paul Mercury Insurance Company, Travelers Casualty and Surety Company, Travelers Casualty and Surety Company of America, and United States Fidelity and Guaranty Company, which resolutions are now in full force and effect, reading as follows:

**RESOLVED**, that the Chairman, the President, any Vice Chairman, any Executive Vice President, any Senior Vice President, any Vice President, any Second Vice President, the Treasurer, any Assistant Treasurer, the Corporate Secretary or any Assistant Secretary may appoint Attorneys-in-Fact and Agents to act for and on behalf of the Company and may give such appointee such authority as his or her certificate of authority may prescribe to sign with the Company's name and seal with the Company's seal bonds, recognizances, contracts of indemnity, and other writings obligatory in the nature of a bond, recognizance, or conditional undertaking, and any of said officers or the Board of Directors at any time may remove any such appointee and revoke the power given him or her; and it is

**FURTHER RESOLVED**, that the Chairman, the President, any Vice Chairman, any Executive Vice President, any Senior Vice President or any Vice President may delegate all or any part of the foregoing authority to one or more officers or employees of this Company, provided that each such delegation is in writing and a copy thereof is filed in the office of the Secretary; and it is

**FURTHER RESOLVED**, that any bond, recognizance, contract of indemnity, or writing obligatory in the nature of a bond, recognizance, or conditional undertaking shall be valid and binding upon the Company when (a) signed by the President, any Vice Chairman, any Executive Vice President, any Senior Vice President or any Vice President, any Second Vice President, the Treasurer, any Assistant Treasurer, the Corporate Secretary or any Assistant Secretary and duly attested and sealed with the Company's seal by a Secretary or Assistant Secretary; or (b) duly executed (under seal, if required) by one or more Attorneys-in-Fact and Agents pursuant to the power prescribed in his or her certificate or their certificates of authority or by one or more Company officers pursuant to a written delegation of authority; and it is

**FURTHER RESOLVED**, that the signature of each of the following officers: President, any Executive Vice President, any Senior Vice President, any Vice President, any Assistant Vice President, any Secretary, any Assistant Secretary, and the seal of the Company may be affixed by facsimile to any power of attorney or to any certificate relating thereto appointing Resident Vice Presidents, Resident Assistant Secretaries or Attorneys-in-Fact for purposes only of executing and attesting bonds and undertakings and other writings obligatory in the nature thereof, and any such power of attorney or certificate bearing such facsimile signature or facsimile seal shall be valid and binding upon the Company and any such power so executed and certified by such facsimile signature and facsimile seal shall be valid and binding on the Company in the future with respect to any bond or understanding to which it is attached.

I, Kori M. Johanson, the undersigned, Assistant Secretary, of Farmington Casualty Company, Fidelity and Guaranty Insurance Company, Fidelity and Guaranty Insurance Underwriters, Inc., Seaboard Surety Company, St. Paul Fire and Marine Insurance Company, St. Paul Guardian Insurance Company, St. Paul Mercury Insurance Company, Travelers Casualty and Surety Company, Travelers Casualty and Surety Company of America, and United States Fidelity and Guaranty Company do hereby certify that the above and foregoing is a true and correct copy of the Power of Attorney executed by said Companies, which is in full force and effect and has not been revoked.

IN TESTIMONY WHEREOF, I have hereunto set my hand and affixed the seals of said Companies this 18<sup>th</sup> day of February, 20 09

WARNING: THIS POWER OF ATTORNEY IS INVALID WITHOUT THE RED BORDER

*Kori M. Johanson*  
Kori M. Johanson, Assistant Secretary



To verify the authenticity of this Power of Attorney, call 1-800-421-3880 or contact us at [www.travelersbond.com](http://www.travelersbond.com). Please refer to the Attorney-In-Fact number, the above-named individuals and the details of the bond to which the power is attached.

STATE OF WEST VIRGINIA  
Purchasing Division**PURCHASING AFFIDAVIT****VENDOR OWING A DEBT TO THE STATE:**

*West Virginia Code* §5A-3-10a provides that: No contract or renewal of any contract may be awarded by the state or any of its political subdivisions to any vendor or prospective vendor when the vendor or prospective vendor or a related party to the vendor or prospective vendor is a debtor and the debt owed is an amount greater than one thousand dollars in the aggregate.

**PUBLIC IMPROVEMENT CONTRACTS & DRUG-FREE WORKPLACE ACT:**

*West Virginia Code* §21-1D-5 provides that: Any solicitation for a public improvement construction contract shall require each vendor that submits a bid for the work to submit at the same time an affidavit that the vendor has a written plan for a drug-free workplace policy in compliance with Article 1D, Chapter 21 of the West Virginia Code. A public improvement construction contract may not be awarded to a vendor who does not have a written plan for a drug-free workplace policy in compliance with Article 1D, Chapter 21 of the West Virginia Code and who has not submitted that plan to the appropriate contracting authority in timely fashion. For a vendor who is a subcontractor, compliance with Section 5, Article 1D, Chapter 21 of the West Virginia Code may take place before their work on the public improvement is begun.

**ANTITRUST:**

In submitting a bid to any agency for the state of West Virginia, the bidder offers and agrees that if the bid is accepted the bidder will convey, sell, assign or transfer to the state of West Virginia all rights, title and interest in and to all causes of action it may now or hereafter acquire under the antitrust laws of the United States and the state of West Virginia for price fixing and/or unreasonable restraints of trade relating to the particular commodities or services purchased or acquired by the state of West Virginia. Such assignment shall be made and become effective at the time the purchasing agency tenders the initial payment to the bidder.

I certify that this bid is made without prior understanding, agreement, or connection with any corporation, firm, limited liability company, partnership or person or entity submitting a bid for the same materials, supplies, equipment or services and is in all respects fair and without collusion or fraud. I further certify that I am authorized to sign the certification on behalf of the bidder or this bid.

**LICENSING:**

Vendors must be licensed and in good standing in accordance with any and all state and local laws and requirements by any state or local agency of West Virginia, including, but not limited to, the West Virginia Secretary of State's Office, the West Virginia Tax Department, West Virginia Insurance Commission, or any other state agencies or political subdivision. Furthermore, the vendor must provide all necessary releases to obtain information to enable the Director or spending unit to verify that the vendor is licensed and in good standing with the above entities.

**CONFIDENTIALITY:**

The vendor agrees that he or she will not disclose to anyone, directly or indirectly, any such personally identifiable information or other confidential information gained from the agency, unless the individual who is the subject of the information consents to the disclosure in writing or the disclosure is made pursuant to the agency's policies, procedures and rules. Vendors should visit [www.state.wv.us/admin/purchase/privacy](http://www.state.wv.us/admin/purchase/privacy) for the Notice of Agency Confidentiality Policies.

Under penalty of law for false swearing (West Virginia Code §61-5-3), it is hereby certified that the vendor acknowledges the information in this said affidavit and is in compliance with the requirements as stated.

Vendor's Name: Pro Contracting Inc.

Authorized Signature: [Signature] Date: 2-17-09



State of West Virginia  
DRUG FREE WORKPLACE CONFORMANCE AFFIDAVIT  
West Virginia Code §21-1D-5

STATE OF WEST VIRGINIA,

COUNTY OF HARRISON, TO-WIT:

I, MATT EVANS, after being first duly sworn, depose and state as follows:

- 1. I am an employee of PRO CONTRACTING, INC.; and,  
(Company Name)
- 2. I do hereby attest that PRO CONTRACTING, INC.  
(Company Name)

maintains a valid written drug free workplace policy and that such policy is in compliance with **West Virginia Code §21-1D-5**.

The above statements are sworn to under the penalty of perjury.

PRO CONTRACTING, INC.  
(Company Name)

By: Matthew B. Lang

Title: Sec.

Date: 2/16/09

Taken, subscribed and sworn to before me this 16<sup>th</sup> day of February 2009.

By Commission expires 1-28-09

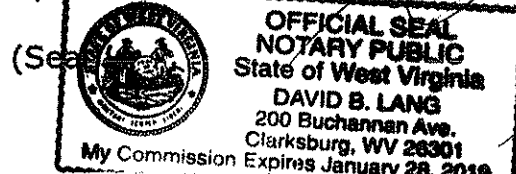

[Signature]  
(Notary Public)

**THIS AFFIDAVIT MUST BE SUBMITTED WITH THE BID IN ORDER TO COMPLY WITH WV CODE PROVISIONS. FAILURE TO INCLUDE THE AFFIDAVIT WITH THE BID SHALL RESULT IN DISQUALIFICATION OF THE BID.**

# CONTRACTOR LICENSE

Authorized by the  
West Virginia Contractor Licensing Board

Number: WV044670

**Classification:**

GENERAL ENGINEERING

PRO CONTRACTING INC  
PO BOX 2442  
CLARKSBURG, WV 26301

**Date Issued**

OCTOBER 06, 2008

**Expiration Date**

OCTOBER 06, 2009

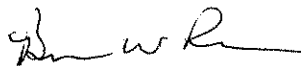

Authorized Company Signature



Chair, West Virginia Contractor  
Licensing Board



WEST VIRGINIA  
CONTRACTOR  
LICENSING  
BOARD

This license, or a copy thereof, must be posted in a conspicuous place at every construction site where work is being performed. This license number must appear in all advertisements, on all bid submissions and on all fully executed and binding contracts. This license cannot be assigned or transferred by licensee. Issued under provisions of West Virginia Code, Chapter 21, Article 11.



**ACORD CERTIFICATE OF LIABILITY INSURANCE**

OP ID IM  
PROCO-1

DATE (MM/DD/YYYY)  
10/16/08

<p><b>PRODUCER</b></p> <p>United Security Agency 139 West Main Street Bridgeport WV 26330 Phone: 304-842-3314 Fax: 304-842-7321</p>	<p>THIS CERTIFICATE IS ISSUED AS A MATTER OF INFORMATION ONLY AND CONFERS NO RIGHTS UPON THE CERTIFICATE HOLDER. THIS CERTIFICATE DOES NOT AMEND, EXTEND OR ALTER THE COVERAGE AFFORDED BY THE POLICIES BELOW.</p>												
<p><b>INSURED</b></p> <p>PRO CONTRACTING INC DAVE LANG P O BOX 2442 CLARKSBURG WV 26302-2442</p>	<table border="1"> <tr> <th>INSURERS AFFORDING COVERAGE</th> <th>NAIC #</th> </tr> <tr> <td>INSURER A: <b>BRICKSTREET INSURANCE</b></td> <td></td> </tr> <tr> <td>INSURER B:</td> <td></td> </tr> <tr> <td>INSURER C:</td> <td></td> </tr> <tr> <td>INSURER D:</td> <td></td> </tr> <tr> <td>INSURER E:</td> <td></td> </tr> </table>	INSURERS AFFORDING COVERAGE	NAIC #	INSURER A: <b>BRICKSTREET INSURANCE</b>		INSURER B:		INSURER C:		INSURER D:		INSURER E:	
INSURERS AFFORDING COVERAGE	NAIC #												
INSURER A: <b>BRICKSTREET INSURANCE</b>													
INSURER B:													
INSURER C:													
INSURER D:													
INSURER E:													

**COVERAGES**

THE POLICIES OF INSURANCE LISTED BELOW HAVE BEEN ISSUED TO THE INSURED NAMED ABOVE FOR THE POLICY PERIOD INDICATED. NOTWITHSTANDING ANY REQUIREMENT, TERM OR CONDITION OF ANY CONTRACT OR OTHER DOCUMENT WITH RESPECT TO WHICH THIS CERTIFICATE MAY BE ISSUED OR MAY PERTAIN, THE INSURANCE AFFORDED BY THE POLICIES DESCRIBED HEREIN IS SUBJECT TO ALL THE TERMS, EXCLUSIONS AND CONDITIONS OF SUCH POLICIES. AGGREGATE LIMITS SHOWN MAY HAVE BEEN REDUCED BY PAID CLAIMS.

INSR LTR	ADD'L INSR	TYPE OF INSURANCE	POLICY NUMBER	POLICY EFFECTIVE DATE (MM/DD/YY)	POLICY EXPIRATION DATE (MM/DD/YY)	LIMITS								
		<p><b>GENERAL LIABILITY</b></p> <p><input type="checkbox"/> COMMERCIAL GENERAL LIABILITY</p> <p><input type="checkbox"/> CLAIMS MADE <input type="checkbox"/> OCCUR</p> <p>GEN'L AGGREGATE LIMIT APPLIES PER:</p> <p><input type="checkbox"/> POLICY <input type="checkbox"/> PRO-JECT <input type="checkbox"/> LOC</p>				<p>EACH OCCURRENCE \$</p> <p>DAMAGE TO RENTED PREMISES (Ea occurrence) \$</p> <p>MED EXP (Any one person) \$</p> <p>PERSONAL &amp; ADV INJURY \$</p> <p>GENERAL AGGREGATE \$</p> <p>PRODUCTS - COMP/OP AGG \$</p>								
		<p><b>AUTOMOBILE LIABILITY</b></p> <p><input type="checkbox"/> ANY AUTO</p> <p><input type="checkbox"/> ALL OWNED AUTOS</p> <p><input type="checkbox"/> SCHEDULED AUTOS</p> <p><input type="checkbox"/> HIRED AUTOS</p> <p><input type="checkbox"/> NON-OWNED AUTOS</p>				<p>COMBINED SINGLE LIMIT (Ea accident) \$</p> <p>BODILY INJURY (Per person) \$</p> <p>BODILY INJURY (Per accident) \$</p> <p>PROPERTY DAMAGE (Per accident) \$</p>								
		<p><b>GARAGE LIABILITY</b></p> <p><input type="checkbox"/> ANY AUTO</p>				<p>AUTO ONLY - EA ACCIDENT \$</p> <p>OTHER THAN EA ACC \$</p> <p>AUTO ONLY: AGG \$</p>								
		<p><b>EXCESS/UMBRELLA LIABILITY</b></p> <p><input type="checkbox"/> OCCUR <input type="checkbox"/> CLAIMS MADE</p> <p>DEDUCTIBLE</p> <p>RETENTION \$</p>				<p>EACH OCCURRENCE \$</p> <p>AGGREGATE \$</p> <p>\$</p> <p>\$</p> <p>\$</p>								
A		<p><b>WORKERS COMPENSATION AND EMPLOYERS' LIABILITY</b></p> <p>ANY PROPRIETOR/PARTNER/EXECUTIVE OFFICER/MEMBER EXCLUDED?</p> <p>If yes, describe under SPECIAL PROVISIONS below</p>	WC1021175401	10/01/08	10/01/09	<table border="1"> <tr> <td>WC STATU-TORY LIMITS</td> <td>OTH-ER</td> </tr> <tr> <td>E.L. EACH ACCIDENT</td> <td>\$ 100000</td> </tr> <tr> <td>E.L. DISEASE - EA EMPLOYEE</td> <td>\$ 100000</td> </tr> <tr> <td>E.L. DISEASE - POLICY LIMIT</td> <td>\$ 500000</td> </tr> </table>	WC STATU-TORY LIMITS	OTH-ER	E.L. EACH ACCIDENT	\$ 100000	E.L. DISEASE - EA EMPLOYEE	\$ 100000	E.L. DISEASE - POLICY LIMIT	\$ 500000
WC STATU-TORY LIMITS	OTH-ER													
E.L. EACH ACCIDENT	\$ 100000													
E.L. DISEASE - EA EMPLOYEE	\$ 100000													
E.L. DISEASE - POLICY LIMIT	\$ 500000													
		OTHER												
DESCRIPTION OF OPERATIONS / LOCATIONS / VEHICLES / EXCLUSIONS ADDED BY ENDORSEMENT / SPECIAL PROVISIONS														

<p><b>CERTIFICATE HOLDER</b></p> <p>PRO CONTRACTING INC DAVE LANG PO BOX 2442 CLARKSBURG WV 26302</p>	<p><b>CANCELLATION</b></p> <p>SHOULD ANY OF THE ABOVE DESCRIBED POLICIES BE CANCELLED BEFORE THE EXPIRATION DATE THEREOF, THE ISSUING INSURER WILL ENDEAVOR TO MAIL _____ DAYS WRITTEN NOTICE TO THE CERTIFICATE HOLDER NAMED TO THE LEFT, BUT FAILURE TO DO SO SHALL IMPOSE NO OBLIGATION OR LIABILITY OF ANY KIND UPON THE INSURER, ITS AGENTS OR REPRESENTATIVES.</p> <p>AUTHORIZED REPRESENTATIVE</p> <p>LISA MCGUIRE <i>Lisa McGuire</i></p>
---	---

reportviewer

AVSGuest@avs.osmre.gov

Email Report PDF XLS

**AVSOFI Report by Entity**

All OFT's where the selected entity is listed in the OFT

10/16/2008 4:28:14 PM  
Guest

Parent	Description	Ownership	SubEntity	Percentage	BeginDate	EndDate
248140 Pro Contracting Inc	Shareholder	Is Owned By	145524 Bryan W Reger	80%	09/18/2008	
248140 Pro Contracting Inc	President	President	145524 Bryan W Reger		09/18/2008	
248140 Pro Contracting Inc	Shareholder	Is Owned By	151167 Matthew Evans	20%	09/18/2008	
248140 Pro Contracting Inc	Secretary	Secretary	151167 Matthew Evans		09/18/2008	