



State of West Virginia
 Department of Administration
 Purchasing Division
 2019 Washington Street East
 Post Office Box 50130
 Charleston, WV 25305-0130

Request for Quotation

RFQ NUMBER
DEP14149

PAGE
1

ADDRESS CORRESPONDENCE TO ATTENTION OF
CHUCK BOWMAN
304-558-2157

RFQ COPY
 TYPE NAME/ADDRESS HERE

VENDOR

J. F. Allen Company
 P.O. Box 2049
 Buckhannon, WV 26201-2049

SHIP TO

ENVIRONMENTAL PROTECTION
 DEPT. OF
 OFFICE OF SPECIAL RECLAMATION
 105 S. RAILROAD STREET
 PHILIPPI, WV
 26416-9998 304-457-3219

DATE PRINTED	TERMS OF SALE	SHIP VIA	F.O.B.	FREIGHT TERMS
05/29/2008				
BID OPENING DATE: 07/23/2008		BID OPENING TIME 01:30PM		

LINE	QUANTITY	UOP	CAT NO	ITEM NUMBER	UNIT PRICE	AMOUNT
0001	1	JB		962-73		
<p>RECLAMATION: RESTORATION OF WATER</p> <p>THE WEST VIRGINIA PURCHASING DIVISION, FOR THE AGENCY, THE WEST VIRGINIA DEPARTMENT OF ENVIRONMENTAL PROTECTION, IS SOLICITING BIDS FROM QUALIFIED CONTRACTORS FOR A CONTRACT TO PROVIDE ALL LABOR AND MATERIALS TO PERFORM RECLAMATION ON THE MINING OPERATION OF FRUSH ENTERPRISES, INC., NOW UNDER REVOKED PERMIT NUMBER(S) S-1008-89. THIS SITE CONSISTS OF APPROXIMATELY 3 ACRES AND IS LOCATED NEAR BRIDGEPORT, WV IN HARRISON COUNTY.</p> <p>THE RECLAMATION SHALL BE PERFORMED UNDER THE GUIDANCE AND GENERAL SUPERVISION OF THE AGENT ASSIGNED TO THE PROJECT FOR THE STATE OF WEST VIRGINIA, DEPARTMENT OF ENVIRONMENTAL PROTECTION.</p> <p>A MANDATORY ON-SITE PREBID CONFERENCE SHALL BE HELD ON 06/24/2008 @ 10:00 AM. FAILURE TO ATTEND THE PREBID CONFERENCE WILL RESULT IN BID DISQUALIFICATION.</p> <p>DIRECTIONS TO PREBID: FROM I-79 STONEWOOD EXIT #115, WEST ON SR 20, TURN RIGHT ON CR 42 AND TRAVEL 2.7 MILES TO SR 23/9. TURN RIGHT AND TRAVEL APPROX. 3.2 MILES TO CR 23/4. TURN LEFT AND TRAVEL APPROX. 0.5 MILES. BEAR LEFT ONTO CR 77/4 APPROX. 1.2 MILES TO ENTRANCE ROAD ON LEFT.</p> <p>ALL WORK MUST BE COMPLETED IN ACCORDANCE WITH THE PLANS AND SPECIFICATIONS PREPARED BY THE DEPARTMENT</p>						

RECEIVED
 2008 JUL 23 A 8:08
 PURCHASING DIVISION
 STATE OF WV

SEE REVERSE SIDE FOR TERMS AND CONDITIONS

SIGNATURE	TELEPHONE	DATE
<i>Michael D. [Signature]</i>	304-472-8890	July 22, 2008
TITLE	FEIN	ADDRESS CHANGES TO BE NOTED ABOVE
Vice President	550328617	

WHEN RESPONDING TO RFQ, INSERT NAME AND ADDRESS IN SPACE ABOVE LABELED 'VENDOR'

**GENERAL TERMS & CONDITIONS
REQUEST FOR QUOTATION (RFQ) AND REQUEST FOR PROPOSAL (RFP)**

1. Awards will be made in the best interest of the State of West Virginia.
2. The State may accept or reject in part, or in whole, any bid.
3. All quotations are governed by the *West Virginia Code* and the *Legislative Rules* of the Purchasing Division.
4. Prior to any award, the apparent successful vendor must be properly registered with the Purchasing Division and have paid the required \$125.00 registration fee.
5. All services performed or goods delivered under State Purchase Orders/Contracts are to be continued for the term of the Purchase Order/Contract, contingent upon funds being appropriated by the Legislature or otherwise being made available. In the event funds are not appropriated or otherwise available for these services or goods, this Purchase Order/Contract becomes void and of no effect after June 30.
6. Payment may only be made after the delivery and acceptance of goods or services.
7. Interest may be paid for late payment in accordance with the *West Virginia Code*.
8. Vendor preference will be granted upon written request in accordance with the *West Virginia Code*.
9. The State of West Virginia is exempt from federal and state taxes and will not pay or reimburse such taxes.
10. The Director of Purchasing may cancel any Purchase Order/Contract upon 30 days written notice to the seller.
11. The laws of the State of West Virginia and the *Legislative Rules* of the Purchasing Division shall govern all rights and duties under the Contract, including without limitation the validity of this Purchase Order/Contract.
12. Any reference to automatic renewal is hereby deleted. The Contract may be renewed only upon mutual written agreement of the parties.
13. **BANKRUPTCY:** In the event the vendor/contractor files for bankruptcy protection, this Contract may be deemed null and void, and terminated without further order.
14. **HIPAA Business Associate Addendum -** The West Virginia State Government HIPAA Business Associate Addendum (BAA), approved by the Attorney General, and available online at the Purchasing Division's web site (<http://www.state.wv.us/admin/purchase/vrc/hipaa.htm>) is hereby made part of the agreement. Provided that, the Agency meets the definition of a Covered Entity (45 CFR §160.103) and will be disclosing Protected Health Information (45 CFR §160.103) to the vendor.

INSTRUCTIONS TO BIDDERS

1. Use the quotation forms provided by the Purchasing Division.
2. **SPECIFICATIONS:** Items offered must be in compliance with the specifications. Any deviation from the specifications must be clearly indicated by the bidder. Alternates offered by the bidder as **EQUAL** to the specifications must be clearly defined. A bidder offering an alternate should attach complete specifications and literature to the bid. The Purchasing Division may waive minor deviations to specifications.
3. Complete all sections of the quotation form.
4. Unit prices shall prevail in cases of discrepancy.
5. All quotations are considered F.O.B. destination unless alternate shipping terms are clearly identified in the quotation.
6. **BID SUBMISSION:** All quotations must be delivered by the bidder to the office listed below prior to the date and time of the bid opening. Failure of the bidder to deliver the quotations on time will result in bid disqualifications.

SIGNED BID TO:

Department of Administration
Purchasing Division
2019 Washington Street East
Post Office Box 50130
Charleston, WV 25305-0130



State of West Virginia
 Department of Administration
 Purchasing Division
 2019 Washington Street East
 Post Office Box 50130
 Charleston, WV 25305-0130

Request for Quotation

RFQ NUMBER
DEP14149

PAGE
2

ADDRESS CORRESPONDENCE TO ATTENTION OF
CHUCK BOWMAN 304-558-2157

RFQ COPY
 TYPE NAME/ADDRESS HERE

PROPERTY

J. F. Allen Company
 P.O. Box 2049
 Buckhannon, WV 26201-2049

SHIP TO

ENVIRONMENTAL PROTECTION
 DEPT. OF
 OFFICE OF SPECIAL RECLAMATION
 105 S. RAILROAD STREET
 PHILIPPI, WV
 26416-9998 304-457-3219

DATE PRINTED 05/29/2008	TERMS OF SALE	SHIP VIA	F.O.B.	FREIGHT TERMS
BID OPENING DATE: 07/23/2008			BID OPENING TIME	01:30PM

LINE	QUANTITY	UOP	CAT NO	ITEM NUMBER	UNIT PRICE	AMOUNT
<p>OF ENVIRONMENTAL PROTECTION AND PURCHASE ORDER ISSUED BY THE DEPARTMENT OF ADMINISTRATION, DIVISION OF PURCHASING.</p> <p>EXHIBIT 5</p> <p>NOTICE TO PROCEED: THIS CONTRACT IS TO BE PERFORMED WITHIN 365 CALENDAR DAYS AFTER THE NOTICE TO PROCEED IS RECEIVED. UNLESS OTHERWISE SPECIFIED, THE FULLY EXECUTED PURCHASE ORDER WILL BE CONSIDERED NOTICE TO PROCEED.</p> <p>CANCELLATION: THE DIRECTOR OF PURCHASING RESERVES THE RIGHT TO CANCEL THIS CONTRACT IMMEDIATELY UPON WRITTEN NOTICE TO THE VENDOR IF THE MATERIALS OR WORKMANSHIP SUPPLIED ARE OF AN INFERIOR QUALITY OR DO NOT CONFORM WITH THE SPECIFICATIONS OF THE THE BID AND CONTRACT HEREIN.</p> <p>WAGE RATES: THE CONTRACTOR OR SUBCONTRACTOR SHALL PAY THE HIGHER OF THE U.S. DEPARTMENT OF LABOR MINIMUM WAGE RATES AS ESTABLISHED FOR HARRISON COUNTY, PURSUANT TO WEST VIRGINIA CODE 21-5A, ET, SEQ.</p> <p>ARBITRATION: ANY REFERENCES MADE TO ARBITRATION OR INTEREST FOR PAYMENTS DUE (EXCEPT FOR ANY INTEREST REQUIRED BY STATE LAW) CONTAINED IN THIS CONTRACT OR IN ANY AMERICAN INSTITUTE OF ARCHITECTS DOCUMENTS PERTAINING TO THIS CONTRACT ARE HEREBY DELETED.</p> <p>WORKERS' COMPENSATION: VENDOR IS REQUIRED TO PROVIDE A CERTIFICATE FROM WORKERS' COMPENSATION IF SUCCESSFUL.</p> <p>ALL OF THE ITEMS CHECKED BELOW WILL BE A REQUIREMENT OF THIS CONTRACT:</p>						

SEE REVERSE SIDE FOR TERMS AND CONDITIONS

SIGNATURE <i>[Signature]</i>	TELEPHONE 304-472-8890	DATE JULY 22, 2008
TITLE Vice President	FEIN 550328627	ADDRESS CHANGES TO BE NOTED ABOVE

WHEN RESPONDING TO RFQ, INSERT NAME AND ADDRESS IN SPACE ABOVE LABELED 'VENDOR'



State of West Virginia
 Department of Administration
 Purchasing Division
 2019 Washington Street East
 Post Office Box 50130
 Charleston, WV 25305-0130

Request for Quotation

RFO NUMBER
 DEP14149

PAGE
 3

ADDRESS CORRESPONDENCE TO ATTENTION OF
 CHUCK BOWMAN
 304-558-2157

RFQ COPY
 TYPE NAME/ADDRESS HERE

PURCHASER

J. F. Allen Company
 P.O. Box 2049
 Buckhannon, WV 26201-2049

SHIP TO

ENVIRONMENTAL PROTECTION
 DEPT. OF
 OFFICE OF SPECIAL RECLAMATION
 105 S. RAILROAD STREET
 PHILIPPI, WV
 26416-9998 304-457-3219

DATE PRINTED 05/29/2008	TERMS OF SALE	SHIP VIA	F.O.B.	FREIGHT TERMS
BID OPENING DATE: 07/23/2008		BID OPENING TIME 01:30PM		

LINE	QUANTITY	UOP	CAT NO	ITEM NUMBER	UNIT PRICE	AMOUNT
<p>(XX) INSURANCE: SUCCESSFUL VENDOR SHALL FURNISH PROOF OF COMMERCIAL GENERAL LIABILITY INSURANCE PRIOR TO ISSUANCE OF CONTRACT. UNLESS OTHERWISE SPECIFIED IN THE BID DOCUMENTS, THE MINIMUM AMOUNT OF INSURANCE COVERAGE REQUIRED IS \$250,000.</p> <p>() BUILDERS RISK INSURANCE: SUCCESSFUL VENDOR SHALL FURNISH PROOF OF BUILDERS RISK - ALL RISK INSURANCE IN AN AMOUNT EQUAL TO 100% OF THE AMOUNT OF THE CONTRACT.</p> <p>(XX) BONDS: FIVE PERCENT (5%) OF THE TOTAL AMOUNT OF THE BID PAYABLE TO THE STATE OF WEST VIRGINIA, SHALL BE SUBMITTED WITH EACH BID AS A BID BOND. THE SUCCESSFUL BIDDER SHALL ALSO FURNISH A PERFORMANCE BOND AND LABOR/MATERIAL BOND FOR 100% OF THE AMOUNT OF THE CONTRACT. BONDS MAY BE PROVIDED IN THE FORM OF A CERTIFIED CHECK IRREVOCABLE LETTER OF CREDIT, OR BOND FURNISHED BY A SOLVENT SURETY COMPANY AUTHORIZED TO DO BUSINESS IN THE STATE OF WEST VIRGINIA. A LETTER OF CREDIT SUBMITTED IN LIEU OF A PERFORMANCE AND LABOR & MATERIAL BOND WILL ONLY BE ALLOWED FOR PROJECTS UNDER \$100,000. PERSONAL OR BUSINESS CHECKS ARE NOT ACCEPTABLE IN LIEU OF THE 5% BID BOND, PERFORMANCE BOND, OR LABOR/MATERIAL BOND.</p> <p>() MAINTENANCE BOND: A TWO (2) YEAR MAINTENANCE BOND COVERING THE ROOFING SYSTEM WILL BE A REQUIREMENT OF THE SUCCESSFUL VENDOR.</p> <p>REV. 11/00</p> <p>CONTRACTORS LICENSE</p> <p>WEST VIRGINIA STATE CODE 21-11-2 REQUIRES THAT ALL PERSONS DESIRING TO PERFORM CONTRACTING WORK IN THIS</p>						

SEE REVERSE SIDE FOR TERMS AND CONDITIONS

SIGNATURE <i>[Signature]</i>	TELEPHONE 304-472-8890	DATE July 27, 2008
TITLE VICE PRESIDENT	FEIN 550328627	ADDRESS CHANGES TO BE NOTED ABOVE

WHEN RESPONDING TO RFQ, INSERT NAME AND ADDRESS IN SPACE ABOVE LABELED 'VENDOR'



State of West Virginia
 Department of Administration
 Purchasing Division
 2019 Washington Street East
 Post Office Box 50130
 Charleston, WV 25305-0130

Request for Quotation

RFQ NUMBER
DEP14149

PAGE
4

ADDRESS CORRESPONDENCE TO ATTENTION OF
CHUCK BOWMAN
304-558-2157

RFQ COPY
 TYPE NAME/ADDRESS HERE

PURCHASING

J. F. Allen Company
 P.O. Box 2049
 Buckhannon, WV 26201-2049

SHIP TO

ENVIRONMENTAL PROTECTION
 DEPT. OF
 OFFICE OF SPECIAL RECLAMATION
 105 S. RAILROAD STREET
 PHILIPPI, WV
 26416-9998 304-457-3219

DATE PRINTED 05/29/2008	TERMS OF SALE	SHIP VIA	F.O.B.	FREIGHT TERMS
BID OPENING DATE: 07/23/2008			BID OPENING TIME	01:30PM

LINE	QUANTITY	UOP	CAT NO	ITEM NUMBER	UNIT PRICE	AMOUNT
<p>STATE MUST BE LICENSED. THE WEST VIRGINIA CONTRACTORS LICENSING BOARD IS EMPOWERED TO ISSUE THE CONTRACTORS LICENSE. APPLICATIONS FOR A CONTRACTORS LICENSE MAY BE MADE BY CONTACTING THE WEST VIRGINIA DIVISION OF LABOR CAPITOL COMPLEX, BUILDING 3, ROOM 319, CHARLESTON, WV 25305. TELEPHONE: (304) 558-7890.</p> <p>WEST VIRGINIA STATE CODE 21-11-11 REQUIRES ANY PROSPECTIVE BIDDER TO INCLUDE THE CONTRACTORS LICENSE NUMBER ON THEIR BID.</p> <p>BIDDER TO COMPLETE: CONTRACTORS NAME - J. F. Allen Company CONTRACTORS LICENSE NO. - WV000376</p> <p>THE SUCCESSFUL BIDDER IS REQUIRED TO FURNISH A COPY OF THEIR CONTRACTORS LICENSE PRIOR TO ISSUANCE OF A PURCHASE ORDER/CONTRACT.</p> <p>APPLICABLE LAW</p> <p>THE WEST VIRGINIA STATE CODE, PURCHASING DIVISION RULES AND REGULATIONS, AND THE INFORMATION PROVIDED IN THE "REQUEST FOR QUOTATION" ISSUED BY THE PURCHASING DIVISION IS THE SOLE AUTHORITY GOVERNING THIS PROCUREMENT.</p> <p>ANY INFORMATION PROVIDED IN SPECIFICATION MANUALS, OR ANY OTHER SOURCE, VERBAL OR WRITTEN, WHICH CONTRADICTS OR ALTERS THE INFORMATION PROVIDED FROM THE SOURCES AS DESCRIBED IN THE ABOVE PARAGRAPH IS VOID AND OF NO EFFECT.</p> <p>BANKRUPTCY: IN THE EVENT THE VENDOR/CONTRACTOR FILES FOR BANKRUPTCY PROTECTION, THIS CONTRACT IS AUTOMATI-</p>						

SEE REVERSE SIDE FOR TERMS AND CONDITIONS

SIGNATURE 	TELEPHONE 304-472-8890	DATE JULY 22, 2008
TITLE VICE PRESIDENT	FEIN 550328627	ADDRESS CHANGES TO BE NOTED ABOVE

WHEN RESPONDING TO RFQ, INSERT NAME AND ADDRESS IN SPACE ABOVE LABELED 'VENDOR'



State of West Virginia
 Department of Administration
 Purchasing Division
 2019 Washington Street East
 Post Office Box 50130
 Charleston, WV 25305-0130

Request for Quotation

RFQ NUMBER
 DEP14149

PAGE
 5

ADDRESS CORRESPONDENCE TO ATTENTION OF:
 CHUCK BOWMAN
 304-558-2157

RFQ COPY
 TYPE NAME/ADDRESS HERE

VENDOR

J. F. Allen Company
 P.O. Box 2049
 Buckhannon, WV 26201-2049

SHIP TO

ENVIRONMENTAL PROTECTION
 DEPT. OF
 OFFICE OF SPECIAL RECLAMATION
 105 S. RAILROAD STREET
 PHILIPPI, WV
 26416-9998 304-457-3219

DATE PRINTED 05/29/2008	TERMS OF SALE	SHIP VIA	FOB	FREIGHT TERMS
BID OPENING DATE: 07/23/2008		BID OPENING TIME 01:30PM		

LINE	QUANTITY	UOP	CAT NO	ITEM NUMBER	UNIT PRICE	AMOUNT
<p>CALLY NULL AND VOID, AND IS TERMINATED WITHOUT FURTHER ORDER.</p> <p>PREFERENCE FOR USE OF DOMESTIC STEEL PRODUCTS</p> <p>1. EXCEPT WHEN AUTHORIZED BY THE DIRECTOR OF THE PURCHASING DIVISION PURSUANT TO SUBSECTION 2 BELOW, NO CONTRACTOR MAY USE OR SUPPLY STEEL PRODUCTS FOR A STATE CONTRACT PROJECT OTHER THAN THOSE STEEL PRODUCTS MADE IN THE UNITED STATES. AS USED USED IN THIS CONTRACT,</p> <p>A. "STATE CONTRACT PROJECT" MEANS ANY ERECTION OR CONSTRUCTION OF, OR ANY ADDITION TO, ALTERATION OF OR OTHER IMPROVEMENT TO ANY BUILDING OR STRUCTURE, INCLUDING, BUT NOT LIMITED TO, ROADS OR HIGHWAYS, OR THE INSTALLATION OF ANY HEATING OR COOLING OR VENTILATING PLANTS OR OTHER EQUIPMENT, OR THE SUPPLY OF AND MATERIALS FOR SUCH PROJECTS, PURSUANT TO A CONTRACT WITH THE STATE OF WEST VIRGINIA FOR WHICH BIDS WERE SOLICITED ON OR AFTER JUNE 6, 2001.</p> <p>B. "STEEL PRODUCTS" MEANS PRODUCTS ROLLED, FORMED SHAPED, DRAWN, EXTRUDED, FORGED, CAST, FABRICATED OR OTHERWISE SIMILARLY PROCESSED, OR PROCESSED BY A COMBINATION OF TWO OR MORE OF SUCH OPERATIONS, FROM STEEL MADE BY THE OPEN HEARTH, BASIC OXYGEN, ELECTRIC FURNACE, BESSEMER OR OTHER STEEL MAKING PROCESS.</p> <p>C. "UNITED STATES" MEANS THE UNITED STATES OF AMERICA AND INCLUDES ALL TERRITORY, CONTINENTAL OR INSULAR, SUBJECT TO THE JURISDICTION OF THE UNITED STATES.</p>						

SEE REVERSE SIDE FOR TERMS AND CONDITIONS

SIGNATURE <i>[Signature]</i>	TELEPHONE 304-472-8890	DATE July 22, 2008
TITLE Vice President	FEIN 550328627	ADDRESS CHANGES TO BE NOTED ABOVE

WHEN RESPONDING TO RFQ, INSERT NAME AND ADDRESS IN SPACE ABOVE LABELED 'VENDOR'



State of West Virginia
 Department of Administration
 Purchasing Division
 2019 Washington Street East
 Post Office Box 50130
 Charleston, WV 25305-0130

Request for Quotation

RFQ NUMBER
DEP14149

PAGE
6

ADDRESS CORRESPONDENCE TO ATTENTION OF
CHUCK BOWMAN
304-558-2157

RFQ COPY

TYPE NAME/ADDRESS HERE

PURCHASING

J. F. Allen Company
 P.O. Box 2049
 Buckhannon, WV 26201-2049

SHIP TO

ENVIRONMENTAL PROTECTION
 DEPT. OF
 OFFICE OF SPECIAL RECLAMATION
 105 S. RAILROAD STREET
 PHILIPPI, WV
 26416-9998 304-457-3219

DATE PRINTED	TERMS OF SALE	SHIP VIA	F.O.B.	FREIGHT TERMS
05/29/2008				
BID OPENING DATE: 07/23/2008		BID OPENING TIME 01:30PM		

LINE	QUANTITY	UOP	CAT. NO.	ITEM NUMBER	UNIT PRICE	AMOUNT
2.						
<p>THE DIRECTOR OF THE PURCHASING DIVISION MAY, IN WRITING, AUTHORIZE THE USE OF FOREIGN STEEL PRODUCTS IF:</p> <p>A. THE COST FOR EACH CONTRACT ITEM USED DOES NOT EXCEED ONE TENTH OF ONE PERCENT (.1%) OF THE TOTAL CONTRACT COST OR TWO THOUSAND FIVE HUNDRED DOLLARS (2,500.00), WHICHEVER IS GREATER. FOR THE PURPOSES OF THIS SECTION, THE COST IS THE VALUE OF THE STEEL PRODUCT AS DELIVERED TO THE PROJECT OR,</p> <p>B. THE DIRECTOR OF THE PURCHASING DIVISION DETERMINES THAT SPECIFIED STEEL MATERIALS ARE NOT PRODUCED IN THE UNITED STATES IN SUFFICIENT QUANTITY OR OTHERWISE ARE NOT REASONABLY AVAILABLE TO MEET CONTRACT REQUIREMENTS.</p> <p>B. A CONTRACTOR WHO USES STEEL PRODUCTS IN VIOLATION OF THIS SECTION MAY BE SUBJECT TO CIVIL PENALTIES PURSUANT TO WV CODE SECTION 5A-3-56.</p>						
REV. 10/01/01						
EXHIBIT 7						
DOMESTIC ALUMINUM, GLASS & STEEL IN PUBLIC WORKS PROJECTS						
IN ACCORDANCE WITH WEST VIRGINIA CODE 5-19-1 ET., SEQ., EVERY CONTRACT FOR CONSTRUCTION, RECONSTRUCTION, ALTERATION, REPAIR, IMPROVEMENT OR MAINTENANCE OF PUBLIC WORKS, WHERE THE COST IS MORE THAN \$50,000 AND, IN THE CASE OF STEEL ONLY, WHERE THE COST OF STEEL IS MORE THAN \$50,000 OR WHERE MORE THAN 10,000 POUNDS OF						

SEE REVERSE SIDE FOR TERMS AND CONDITIONS

SIGNATURE	TITLE	FEIN	TELEPHONE	DATE
<i>[Signature]</i>	Vice President	550328627	304-472-8890	JULY 22, 2008
				ADDRESS CHANGES TO BE NOTED ABOVE

WHEN RESPONDING TO RFQ, INSERT NAME AND ADDRESS IN SPACE ABOVE LABELED 'VENDOR'



State of West Virginia
 Department of Administration
 Purchasing Division
 2019 Washington Street East
 Post Office Box 50130
 Charleston, WV 25305-0130

Request for Quotation

RFQ NUMBER DEP14149

PAGE 7

ADDRESS CORRESPONDENCE TO ATTENTION OF: CHUCK BOWMAN 304-558-2157

RFQ COPY
 TYPE NAME/ADDRESS HERE

VENDOR

J. F. Allen Company
 P.O. Box 2049
 Buckhannon, WV 26201-2049

SHIP TO

ENVIRONMENTAL PROTECTION
 DEPT. OF
 OFFICE OF SPECIAL RECLAMATION
 105 S. RAILROAD STREET
 PHILIPPI, WV
 26416-9998 304-457-3219

DATE PRINTED 05/29/2008	TERMS OF SALE	SHIP VIA	F.O.B.	FREIGHT TERMS
BID OPENING DATE: 07/23/2008		BID OPENING TIME		01:30PM

LINE	QUANTITY	UOP	CAT NO	ITEM NUMBER	UNIT PRICE	AMOUNT
<p>STEEL ARE REQUIRED, THE STATE WILL ACCEPT ONLY ALUMINUM GLASS, OR STEEL PRODUCTS PRODUCED IN THE UNITED STATES. IN ADDITION, ITEMS OF MACHINERY OR EQUIPMENT PURCHASED FOR USE AT THE SITE OF PUBLIC WORKS SHALL BE MADE OF DOMESTIC ALUMINUM, GLASS OR STEEL, UNLESS THE COST OF THE PRODUCT IS LESS THAN \$50,000 OR LESS THAN 10,000 POUNDS OF STEEL ARE USED IN PUBLIC WORKS PROJECTS.</p> <p>FOREIGN MADE ALUMINUM, GLASS OR STEEL PRODUCTS MAY BE ACCEPTED ONLY IF THE COST OF DOMESTIC PRODUCTS IS FOUND TO BE UNREASONABLE. SUCH COST IS UNREASONABLE IF IT IS 20% OR MORE HIGHER THAN THE BID PRICE FOR FOREIGN MADE PRODUCTS. IF THE DOMESTIC ALUMINUM, GLASS OR STEEL PRODUCTS TO BE SUPPLIED OR PRODUCED IN A "SUBSTANTIAL LABOR SURPLUS AREA", AS DEFINED BY THE UNITED STATES DEPARTMENT OF LABOR, FOREIGN PRODUCTS MAY BE SUPPLIED ONLY IF DOMESTIC PRODUCTS ARE 30% OR MORE HIGHER IN PRICE THAN THE FOREIGN MADE PRODUCTS.</p> <p>IF, PRIOR TO THE AWARD OF A CONTRACT UNDER THE ABOVE PROVISIONS, THE SPENDING OFFICER OF THE SPENDING UNIT DETERMINES THAT THERE EXISTS A BID FOR LIKE FOREIGN ALUMINUM, GLASS OR STEEL THAT IS REASONABLE AND LOWER THAN THE LOWEST BID DOMESTIC PRODUCTS, THE SPENDING OFFICE MAY REQUEST, IN WRITING, A REEVALUATION AND REDUCTION IN THE LOWEST BID FOR SUCH DOMESTIC PRODUCTS. ALL VENDORS MUST INDICATE IN THEIR BID IF THEY ARE SUPPLYING FOREIGN ALUMINUM, GLASS OR STEEL.</p> <p>REV. 3/88</p> <p>EXHIBIT 9</p> <p>NOTICE FOR ISSUANCE & ACKNOWLEDGEMENT OF CONSTRUCTION PROJECT ADDENDA</p>						

SEE REVERSE SIDE FOR TERMS AND CONDITIONS

SIGNATURE <i>[Signature]</i>	TELEPHONE 304-472-8890	DATE July 22, 2008
TITLE Vice President	FEIN 550328627	ADDRESS CHANGES TO BE NOTED ABOVE

WHEN RESPONDING TO RFQ, INSERT NAME AND ADDRESS IN SPACE ABOVE LABELED 'VENDOR'



State of West Virginia
 Department of Administration
 Purchasing Division
 2019 Washington Street East
 Post Office Box 50130
 Charleston, WV 25305-0130

Request for Quotation

RFQ NUMBER
DEP14149

PAGE
8

ADDRESS CORRESPONDENCE TO ATTENTION OF
CHUCK BOWMAN
304-558-2157

RFQ COPY
 TYPE NAME/ADDRESS HERE

PURCHASING

J. F. Allen Company
 P.O. Box 2049
 Buckhannon, WV 26201-2049

SHIP TO

ENVIRONMENTAL PROTECTION
 DEPT. OF
 OFFICE OF SPECIAL RECLAMATION
 105 S. RAILROAD STREET
 PHILIPPI, WV
 26416-9998 304-457-3219

DATE PRINTED 05/29/2008	TERMS OF SALE	SHIP VIA	F.O.B.	FREIGHT TERMS
BID OPENING DATE: 07/23/2008		BID OPENING TIME 01:30PM		

LINE	QUANTITY	UOP	CAT NO	ITEM NUMBER	UNIT PRICE	AMOUNT
<p>THE ARCHITECT/ENGINEER AND/OR AGENCY SHALL BE REQUIRED TO ABIDE BY THE FOLLOWING SCHEDULE IN ISSUING CONSTRUCTION PROJECT ADDENDA FOR STATE AGENCIES:</p> <p>(1) THE ARCHITECT/ENGINEER SHALL PREPARE THE ADDENDUM AND A LIST OF ALL PARTIES THAT HAVE PROCURED DRAWINGS AND SPECIFICATIONS FOR THE PROJECT. THE ADDENDUM AND LIST SHALL BE FORWARDED TO THE BUYER IN THE STATE PURCHASING DIVISION. THE ARCHITECT/ENGINEER SHALL ALSO SEND A COPY OF THE ADDENDUM TO THE STATE AGENCY FOR WHICH THE CONTRACT IS ISSUED.</p> <p>(2) THE BUYER SHALL SEND THE ADDENDUM TO ALL INTERESTED PARTIES AND IF NECESSARY, EXTEND THE BID OPENING DATE ANY ADDENDUM SHOULD BE RECEIVED BY THE BUYER WITHIN FOURTEEN (14) DAYS PRIOR TO THE BID OPENING DATE</p> <p>(3) ALL ADDENDA SHOULD BE FORMALLY ACKNOWLEDGED BY ALL BIDDERS AND SUBMITTED TO THE STATE PURCHASING DIVISION. THE SAME RULES AND REGULATIONS THAT APPLY TO THE ORIGINAL BIDDING DOCUMENT SHALL ALSO APPLY TO AN ADDENDUM DOCUMENT. THE ONLY EXCEPTION MAY BE FOR AN ADDENDUM THAT IS ISSUED FOR THE SOLE PURPOSE OF CHANGING A BID OPENING TIME AND/OR DATE.</p> <p>REV. 11/96</p> <p>EXHIBIT 10</p> <p>DEP14149</p> <p>ADDENDUM ACKNOWLEDGEMENT</p> <p>I HEREBY ACKNOWLEDGE RECEIPT OF THE FOLLOWING CHECKED ADDENDUM(S) AND HAVE MADE THE NECESSARY REVISIONS TO</p>						

SEE REVERSE SIDE FOR TERMS AND CONDITIONS

SIGNATURE <i>[Signature]</i>	TELEPHONE 304-472-8890	DATE July 22, 2008
TITLE VICE PRESIDENT	FEM 550328627	ADDRESS CHANGES TO BE NOTED ABOVE

WHEN RESPONDING TO RFQ, INSERT NAME AND ADDRESS IN SPACE ABOVE LABELED 'VENDOR'



State of West Virginia
 Department of Administration
 Purchasing Division
 2019 Washington Street East
 Post Office Box 50130
 Charleston, WV 25305-0130

Request for Quotation

RFQ NUMBER
 DEP14149

PAGE
 9

ADDRESS CORRESPONDENCE TO ATTENTION OF
 CHUCK BOWMAN
 304-558-2157

RFQ COPY

TYPE NAME/ADDRESS HERE

V
E
N
D
O
R

J. F. Allen Company
 P.O. Box 2049
 Buckhannon, WV 26201-2049

S
H
I
P
T
O

ENVIRONMENTAL PROTECTION
 DEPT. OF
 OFFICE OF SPECIAL RECLAMATION
 105 S. RAILROAD STREET
 PHILIPPI, WV
 26416-9998 304-457-3219

DATE PRINTED 05/29/2008	TERMS OF SALE	SHIP VIA	F.O.B.	FREIGHT TERMS
BID OPENING DATE: 07/23/2008			BID OPENING TIME	01:30PM

LINE	QUANTITY	UOP	CAT NO.	ITEM NUMBER	UNIT PRICE	AMOUNT
				MY PROPOSAL, PLANS AND/OR SPECIFICATION, ETC.		
				ADDENDUM NOS :		
				NO. 1 ✓		
				NO. 2		
				NO. 3		
				NO. 4		
				NO. 5		
<p>I UNDERSTAND THAT FAILURE TO CONFIRM THE RECEIPT OF THE ADDENDUM(S) MAY BE CAUSE FOR REJECTION OF THE BIDS.</p> <p>VENDOR MUST CLEARLY UNDERSTAND THAT ANY VERBAL REPRESENTATION MADE OR ASSUMED TO BE MADE DURING ANY ORAL DISCUSSION HELD BETWEEN VENDOR'S REPRESENTATIVES AND ANY STATE PERSONNEL IS NOT BINDING. ONLY THE INFORMATION ISSUED IN WRITING AND ADDED TO THE SPECIFICATIONS BY AN OFFICIAL ADDENDUM IS BINDING.</p>						
				<i>Michael D. Byrd</i>	SIGNATURE	
				J. F. ALLEN COMPANY	COMPANY	
				JULY 22, 2008	DATE	
REV. 11/96						
NOTICE						

SEE REVERSE SIDE FOR TERMS AND CONDITIONS

SIGNATURE <i>[Signature]</i>	TELEPHONE 304-472-8890	DATE JULY 22, 2008
TITLE VICE PRESIDENT	FEIN 550328627	ADDRESS CHANGES TO BE NOTED ABOVE

WHEN RESPONDING TO RFQ, INSERT NAME AND ADDRESS IN SPACE ABOVE LABELED 'VENDOR'



State of West Virginia
 Department of Administration
 Purchasing Division
 2019 Washington Street East
 Post Office Box 50130
 Charleston, WV 25305-0130

Request for Quotation

RFQ NUMBER
DEP14149

PAGE
10

ADDRESS CORRESPONDENCE TO ATTENTION OF:
CHUCK BOWMAN
304-558-2157

RFQ COPY
 TYPE NAME/ADDRESS HERE

VENDOR

J. F. Allen Company
 P.O. Box 2049
 Buckhannon, WV 26201-2049

SHIP TO

ENVIRONMENTAL PROTECTION
 DEPT. OF
 OFFICE OF SPECIAL RECLAMATION
 105 S. RAILROAD STREET
 PHILIPPI, WV
 26416-9998 304-457-3219

DATE PRINTED 05/29/2008	TERMS OF SALE	SHIP VIA	F.O.B.	FREIGHT TERMS
BID OPENING DATE: 07/23/2008		BID OPENING TIME 01:30PM		

LINE	QUANTITY	UOP	CAT NO	ITEM NUMBER	UNIT PRICE	AMOUNT
<p>A SIGNED BID MUST BE SUBMITTED TO:</p> <p>DEPARTMENT OF ADMINISTRATION PURCHASING DIVISION BUILDING 15 2019 WASHINGTON STREET, EAST CHARLESTON, WV 25305-0130</p> <p>THE BID SHOULD CONTAIN THIS INFORMATION ON THE FACE OF THE ENVELOPE OR THE BID MAY NOT BE CONSIDERED:</p> <p>SEALED BID</p> <p>BUYER: CB-23</p> <p>REQ. NO.: DEP14149</p> <p>BID OPENING DATE: 07/23/2008</p> <p>BID OPENING TIME: 1:30 P.M.</p> <p>PLEASE PROVIDE A FAX NUMBER IN CASE IT IS NECESSARY TO CONTACT YOU REGARDING YOUR BID: <u>304-472-8897</u></p> <p>PLEASE PRINT OR TYPE NAME OF PERSON TO CONTACT CONCERNING THIS QUOTE: <u>Michael D. Griffith</u></p>						

SEE REVERSE SIDE FOR TERMS AND CONDITIONS

SIGNATURE <i>[Signature]</i>	TELEPHONE 304-472-8890	DATE JULY 22, 2008
TITLE VICE PRESIDENT	FEIN 550328627	ADDRESS CHANGES TO BE NOTED ABOVE

WHEN RESPONDING TO RFQ, INSERT NAME AND ADDRESS IN SPACE ABOVE LABELED 'VENDOR'

LOCATION MAP

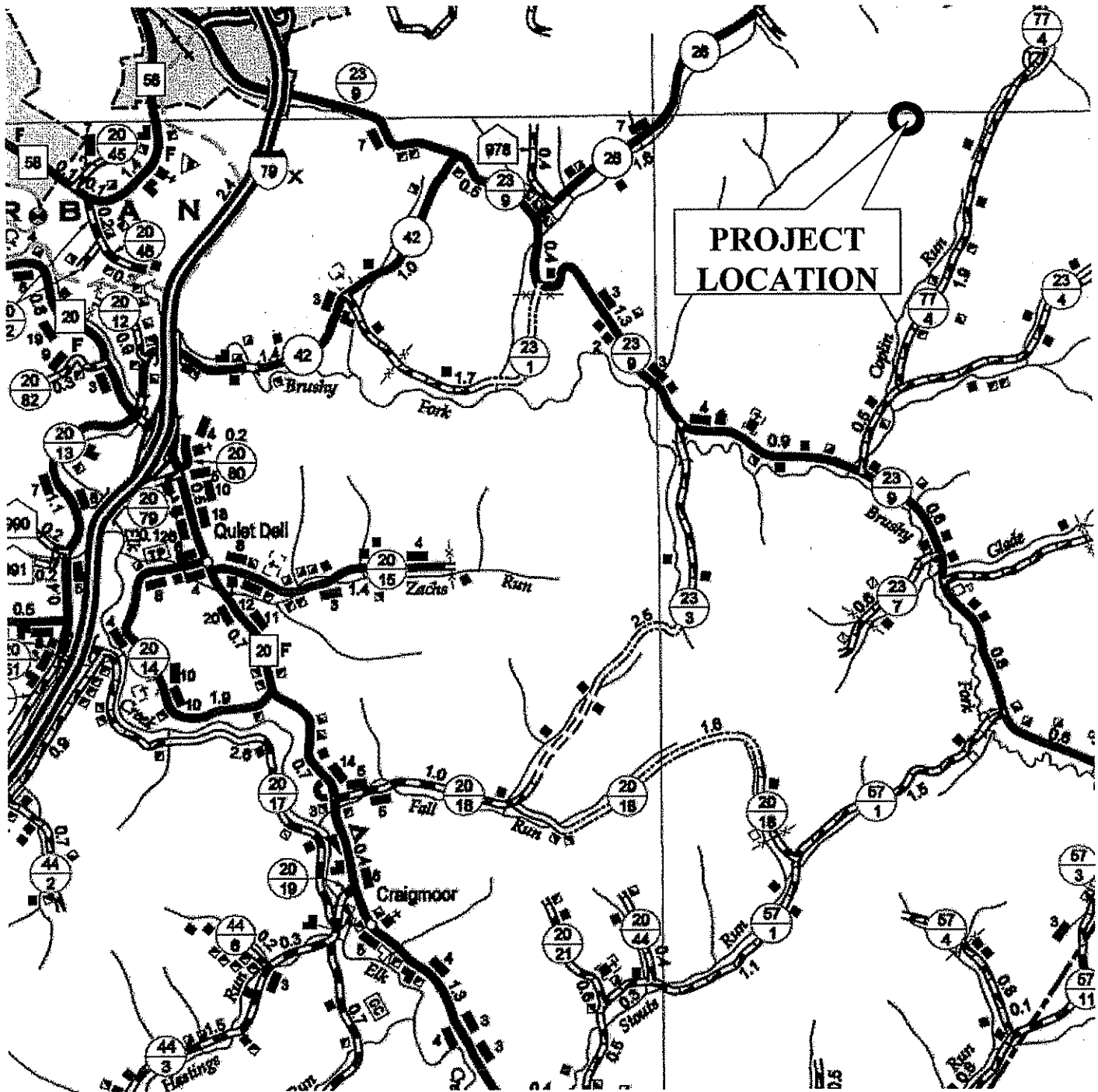

From I-79 Stonewood Exit # 115, West on St. Route 20 turn right on County Route 42 and travel 2.7 miles to St. Route 23/9. Turn right and travel approximately 3.2 miles to County Route 23/4. Turn Left and travel approximately 0.5 miles. Bear left onto County Route 77/4 approximately 1.2 miles to entrance road on left.

BUYER CB-23	PAGE 012	REQ. OR PO NO. DEP 14149
SPENDING UNIT WEST VIRGINIA DEPARTMENT OF ENVIRONMENTAL PROTECTION/SPECIAL RECLAMATION		

WV-36a STATE OF WEST VIRGINIA
 Rev. 1/29/02 PURCHASING CONTINUATION SHEET
 VENDOR:

SCOPE OF WORK

The successful bidder shall provide appropriate equipment, materials, labor and any technical services needed for the successful reclamation of Frush Enterprises, Inc., Permit S-1008-89, and any disturbance associated with such operation. The General Performance Standards (GPS) shall apply to all items in Scope of Work.

Work necessary on this site will include the following items, but is not limited to these:

1. Upon mobilization to the site, which will be directed in a written Notice to Proceed, the access roads shall be developed in accordance with bid item # 3.0 & 4.0. If, fuel and lubricants are to be stored on site, bid item # 2.0 shall be in place before fuel is delivered. Project sign is to be obtained and installed.
2. Storm water management in the form as described in bid item # 7.0 & 8.0 shall be installed (described locations).
3. Reclamation is to be according to the attached specifications, plans, and clarifying discussions at the Pre-Bid Conference.
4. Construction stakeout as necessary to carry out work. (Bid Item # 6.0)
5. Construct riprap ditches.
6. Construct settling pond.
7. Remove debris from site.
8. Install culverts.
9. Bore, jack in casing, install pipe to drain mine.
10. Any other site specific items required.

I, David B. McCoy, the undersigned, hereby certify ¹ that this Reclamation Plan is correct and shows to the best of my knowledge and belief all the information required by the surface mining laws of the State of West Virginia. The source of information was the approved mining and reclamation plan contained in the forfeited surface mine permit, existing site conditions and information contained in the WV DEP, Inspection and Enforcement files.

David B. McCoy

Registered Professional Engineer WV No. 14375

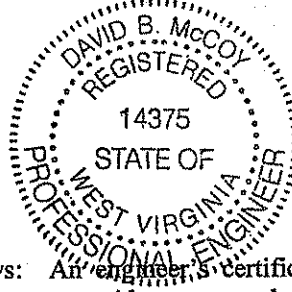

DBS

Date: 4-21-08

¹ The term "certify" as used herein is defined as follows: An engineer's certification of conditions is a declaration of professional judgment. It does not constitute a warranty or guarantee, either expressed or implied.

J. F. Allen Company
P.O. Box 2049
Buckhannon, WV 26201-2049

BUYER CB-23	PAGE 013	REQ. OR PO NO. DEP 14149
SPENDING UNIT WEST VIRGINIA DEPARTMENT OF ENVIRONMENTAL PROTECTION/SPECIAL RECLAMATION		

WV-36a STATE OF WEST VIRGINIA
Rev. 1/29/02 PURCHASING CONTINUATION SHEET
VENDOR:

ITEM NO.	QUANTITY	DESCRIPTION	UNIT PRICE	AMOUNT
BID SCHEDULE				
PERMIT NAME: <u>FRUSH ENTERPRISES, INC.</u>				
PERMIT NUMBER(S): <u>S-1008-89</u>				
The DEP reserves the right to request additional information and supporting documentation regarding unit prices when the unit price appears to be unreasonable.				
1.0	LUMP SUM	<u>MOBILIZATION/DEMOBILIZATION/PROJECT SIGN</u> (5% Total Bid Maximum for this permit)	LUMP SUM	\$ <u>20,000.00</u>
2.0	LUMP SUM	<u>SPILL CONTAINMENT AREA (S.C.A.)</u> (\$1,000.00 Maximum Bid for this permit)	LUMP SUM	\$ <u>1,000.00</u>
3.0	<u>1500 LF</u>	<u>ACCESS ROAD UPGRADE</u>	\$ <u>7.00</u> PER LF	\$ <u>10,500.00</u>
3.1	<u>175 LF</u>	<u>FILTER FABRIC FOR ROAD UPGRADE</u>	\$ <u>3.00</u> PER LF	\$ <u>525.00</u>
3.2	<u>50 TON</u>	<u>INCIDENTAL #1 STONE FOR ROAD UPGRADE</u>	\$ <u>35.00</u> PER TON	\$ <u>1,750.00</u>
4.0	<u>1680 LF</u>	<u>CONSTRUCT NEW ACCESS ROAD</u>	\$ <u>20.00</u> PER LF	\$ <u>33,600.00</u>
5.0		<u>REVEGETATION</u>		
5.1	<u>3 AC</u>	<u>AGRICULTURAL LIME</u>	\$ <u>500.00</u> PER ACRE	\$ <u>1,500.00</u>
5.2	<u>3 AC</u>	<u>FERTILIZER</u>	\$ <u>1,000.00</u> PER ACRE	\$ <u>3,000.00</u>
5.3	<u>3 AC</u>	<u>MULCH</u>	\$ <u>1,000.00</u> PER ACRE	\$ <u>3,000.00</u>
5.4	<u>3 AC</u>	<u>VEGETATIVE SPECIES</u>	\$ <u>750.00</u> PER ACRE	\$ <u>2,250.00</u>
6.0	LUMP SUM	<u>CONSTRUCTION STAKEOUT</u> (Limited to 5% Total Bid)	LUMP SUM	\$ <u>20,000.00</u>
7.0	<u>2 EA</u>	<u>CONSTRUCTED SEDIMENT CONTROL SUMPS</u>	\$ <u>500.00</u> PER EA	\$ <u>1,000.00</u>

J. F. Allen Company

P.O. Box 2049

Buckhannon, WV 26201-2049

BUYER CB-23	PAGE 014	REQ. OR PO NO. DEP 14149
----------------	-------------	-----------------------------

SPENDING UNIT
WEST VIRGINIA DEPARTMENT OF ENVIRONMENTAL
PROTECTION/SPECIAL RECLAMATION

WV-36a

STATE OF WEST VIRGINIA

Rev. 1/29/02

PURCHASING CONTINUATION SHEET

VENDOR:

8.0	<u>500 LF</u>	<u>HAYBALE DIKE</u> (Max. Bid \$5.00 Per LF)	\$ <u>5.00</u> PER LF	\$ <u>2,500.00</u>
9.0		<u>HORIZONTAL BORING</u>		
9.1	LUMP SUM	<u>BORING PIT EXCAVATION</u>	LUMP SUM	\$ <u>3,000.00</u>
9.2	<u>1440 LF</u>	<u>PILOT HOLES</u>	\$ <u>60.00</u> PER LF	\$ <u>86,400.00</u>
9.3	<u>360 LF</u>	<u>DOUBLE 12-INCH DIAMETER MINE DRAINS</u>	\$ <u>368.00</u> PER LF	\$ <u>132,480.00</u>
10.0	<u>500 LF</u>	<u>DOUBLE 12-INCH HDPE PIPE</u>	\$ <u>70.00</u> PER LF	\$ <u>35,000.00</u>
11.0	<u>2 EA</u>	<u>WYE (12" HDPE, LATERAL 45°)</u>	\$ <u>1,500.00</u> PER EA	\$ <u>3,000.00</u>
12.0	<u>2 EA</u>	<u>FLANGE (12" HDPE)</u>	\$ <u>1,500.00</u> PER EA	\$ <u>3,000.00</u>
13.0	<u>1100 LF</u>	<u>RIPRAP V-DITCH</u>	\$ <u>16.00</u> PER LF	\$ <u>17,600.00</u>
14.0	<u>160 LF</u>	<u>HDPE CULVERTS -12 INCH</u>	\$ <u>18.00</u> PER LF	\$ <u>2,880.00</u>
15.0	<u>120 LF</u>	<u>HDPE CULVERTS -24 INCH</u>	\$ <u>32.00</u> PER LF	\$ <u>3,840.00</u>
16.0	LUMP SUM	<u>STRUCTURE AND/OR DEBRIS REMOVAL</u>	LUMP SUM	\$ <u>3,000.00</u>
17.0	LUMP SUM	<u>CONSTRUCT SETTLING POND</u>	LUMP SUM	\$ <u>12,000.00</u>
18.0	LUMP SUM	<u>WATER TREATMENT</u>	LUMP SUM	\$ <u>4,000.00</u>
19.0	LUMP SUM	<u>CLEAR AND GRUB</u>	LUMP SUM	\$ <u>10,000.00</u>
20.0	LUMP SUM	<u>BAFFLE CURTAIN</u>	LUMP SUM	\$ <u>3,000.00</u>
TOTAL PERMIT S-1008-89				\$ <u>446,825.00</u>

BUYER CB-23	PAGE 015	REQ. OR PO NO. DEP 14149
SPENDING UNIT WEST VIRGINIA DEPARTMENT OF ENVIRONMENTAL PROTECTION/SPECIAL RECLAMATION		

WV-36a STATE OF WEST VIRGINIA
 Rev. 1/29/02 PURCHASING CONTINUATION SHEET
 VENDOR:

BID ITEM TECHNICAL SPECIFICATIONS

1.0 MOBILIZATION/DEMobilIZATION/PROJECT SIGN **PROJECT SIGN**

A project sign shall be obtained or manufactured and installed as indicated on the attached specifications and details. Payment for this sign shall be incidental to the mobilization item. No separate payment will be made.

MOBILIZATION

This work shall consist of the performance of construction preparatory operations, including the movement of personnel, equipment and other facilities to the project site necessary to begin work on a substantial phase of the contract.

DEMobilIZATION

Prior to demobilization, an inspection shall be conducted by the Department of Environmental Protection and the contractor to insure compliance with contract performance. Once compliance is ascertained, demobilization activities can be initiated and completed. Demobilization shall be totally completed before the invoice for payment shall be processed.

PAYMENT

The lump sum bid for this item shall not exceed 5% of the total bid for this permit. Payment shall be made in two 50% amounts, one upon completion of the mobilization and project sign items and the second payment at the completion of demobilization. No deduction shall be made nor shall any increase be made in the lump sum item amount, regardless of decreases or increases in the final total contract amount or any other reason.

2.0 SPILL CONTAINMENT AREA (S.C.A.)

Spill containment measures shall be used for fuel and lubricant storage areas. All containers, barrels, buckets, cans, etc., are to be legally disposed of off site. Used lubricants are to be disposed of according to state law to minimize pollution to the local surface and ground water supplies. Spills are the responsibility of the contractor and need immediate clean up and maintained at no expense to the State. This S.C.A. shall be constructed in accordance with the typical drawing specification. (See Attachment) Alternate containment measures will be considered for approval by the Program Manager if acceptable results can be shown. Fuel tanks manufactured with secondary containment are desirable. Minimum secondary containment is 110 percent. (Bid limited to \$1,000.00 maximum)

3.0 ACCESS ROAD UPGRADE

The contractor shall maintain and/or construct access road(s) during the reclamation process to provide access on a well drained surface. Plan to upgrade the existing access road to the specifications and details as indicated in the Upgrade Access Road drawing. The access road on the reclamation site shall be graded, sloped, and maintained to drain and provide a road surface free of excessive mud and standing waters at all times while work is in progress. Upon completion of all reclamation activities, a final 3 inch layer of 1 ½ crusher run limestone shall be placed on the roadway. Dust-control measures may be necessary if hauling creates airborne material. Snow removal is to be included in this item. This required road will be approximately fifteen hundred (1500) LF.

3.1 FILTER FABRIC FOR ROAD UPGRADE

Filter Fabric (Tyvar 3401, Mirafi 500X, or equivalent) shall be placed over the completed road foundation (12' width) and covered with a six (6) inch minimum layer of No. 1 limestone (3½ to 1½ inches) (separate bid item). The fabric shall be paid for by the linear foot of road construction.

Filter Fabric is to be used when the road base foundation is unsuitable. Filter Fabric will be placed where directed by the on-site inspector and installed according to the manufacturer's recommendations.

BUYER CB-23	PAGE 016	REQ. OR PO NO. DEP 14149
SPENDING UNIT WEST VIRGINIA DEPARTMENT OF ENVIRONMENTAL PROTECTION/SPECIAL RECLAMATION		

WV-36a STATE OF WEST VIRGINIA
 Rev. 1/29/02 PURCHASING CONTINUATION SHEET
 VENDOR:

3.2 INCIDENTAL #1 STONE FOR ROAD UPGRADE

During construction of culvert installations, roadway ditch improvements, and reshaping of the roadway, areas may need additional base layer stone. After any necessary re-compaction and re-grading work on roadways has been performed by the contractor, a six (6) inch layer of #1 limestone (3.5" to 1.5" size) shall be placed as needed. This stone shall be graded and tracked in with a dozer or other equipment to achieve a compacted base for the final top layer of 1 ½ inch crusher run limestone (separate bid item).

Payment shall be paid per ton of stone applied by weight ticket and will be made at completion of all work and acceptance by DEP.

4.0 CONSTRUCT NEW ACCESS ROAD

This required road will be approximately sixteen hundred and eighty (1680) LF. Accompanying plans show the details of the construction of the road. The contractor shall provide all services, materials, construction layout, equipment, or other materials necessary to execute the work.

SITE PREPARATION

Any areas with soft unsuitable foundation materials shall be undercut to remove this material. The material removed shall be disposed of within the construction area at a site agreed to between the contractor and the DEP on site representative. Construction stake out shall be completed as necessary to complete that phase of the work being undertaken. Payment for the construction stakeout is to be included in the road price. No separate payment will be made for construction stake out.

ROAD CONSTRUCTION

Suitable foundation material shall then be placed in compacted layers not to exceed six (6) inches in thickness to obtain the desired grade and alignment. Compaction equipment is to be approved by DEP on site representative. Filter Fabric (Tyvar 3401, Mirafi 500X, or equivalent) shall be placed over the completed foundation and covered with a six (6) inch minimum layer of No. 1 limestone (3½ to 1½ inches). The No. 1 stone shall then be covered with 1½ inch crusher run limestone so that the surface is choked off and a three (3) inch minimum layer remains on top. The completed road shall have a minimum width of twelve (12) feet and the surface shall be crowned and sloped to both sides a minimum of 24-horizontal to 1 vertical. Any fill sections, if used, shall not impound water. The total length of roadside ditch shall be along the entire length of the road. A roadside drainage ditch shall be established along the hillside of the road, and shall be free draining to any culverts crossing under the road. The ditch shall be vegetated and constructed as indicated in the New Access Road drawing.

5.0 REVEGETATION

The actual seeding date, within the work performance period, shall be at the discretion of the contractor, but a permanent vegetative cover must be established. Verification of materials used shall be required for payment. Seed bed preparation, unless otherwise approved, shall be conducted by industrial disks or tracking with heavy equipment with cleat marks across slope and parallel to the final contours. The surface shall be tracked, track to track. Seeding shall commence after seedbed preparation on a loose and uncompacted soil and with the approval of the Department of Environmental Protection. Contractor shall provide equipment as necessary to secure approval of the seedbed. Revegetation activities shall be carried out in a continuous, concurrent, timely and uniform manner. Failure to do this may result in nonpayment for portions of or the entire Revegetation item. Hydroseeding or broadcast seeding with the approved species is acceptable. The application rate may be increased but the ratio is to remain constant, but no additional monetary compensation will be awarded. Areas outside the limits of construction, disturbed by the contractor, shall be revegetated by the contractor at no expense to DEP. Water utilized for hydroseeding shall be free of injurious or other toxic substances harmful to plant life. The source of water is subject to the approval of the DEP Specialist. It shall be the vendor's responsibility to repeat the procedures under REVEGETATION until permanent vegetation is established. The acreage quantities in this contract are for bidding purposes only.

A warranty period of one (1) year shall commence upon completion and payment of the revegetation item of the contract. No payment will be made for additional seeding necessary to comply with warranty requirements. The

BUYER CB-23	PAGE 017	REQ. OR PO NO. DEP 14149
SPENDING UNIT WEST VIRGINIA DEPARTMENT OF ENVIRONMENTAL PROTECTION/SPECIAL RECLAMATION		

WV-36a STATE OF WEST VIRGINIA
 Rev. 1/29/02 PURCHASING CONTINUATION SHEET
 VENDOR:

warranty period will be extended for one (1) year from the date of the last augmented seeding done by the contractor. The performance bond and labor and materials bond shall remain in effect throughout the warranty period. The Standards for Evaluating Vegetative Cover as presented in Title 38, CSR2, Section 9 of the West Virginia Surface Mining Reclamation Regulations will apply.

Equipment for the retracking/scarification to eliminate rills and gullies shall be mobilized and utilized to produce slopes consistent with the regrading and topsoiling bid item prior to warranty reseeding. No additional payment will be made by DEP for this warranty work.

5.1 AGRICULTURAL LIME

Unless otherwise specified, all lime used shall be registered with the West Virginia Department of Agriculture, have an 85% minimum calcium carbonate equivalent, and meet the fineness classification no larger than that for ground lime. The following fineness classifications or combinations of lime are acceptable:

- Pulverized - 100% passing a U.S. Standard 20 mesh sieve
 - 70% passing a U.S. Standard 100 mesh sieve
- Ground - 90% passing a U.S. Standard 20 mesh sieve
 - 50% passing a U.S. Standard 60 mesh sieve
 - 35% passing a U.S. Standard 100 mesh sieve

Use of blends and low-grade agricultural liming materials shall require prior approval. Lime shall be spread as soon as possible after delivery to site. Lime shall be applied evenly and uniformly distributed over the treated area. Lime shall be thoroughly mixed into the soil material. Lime subjected to adverse conditions before spreading will be deemed unacceptable. Failure to complete this phase shall result in nonpayment of this bid item.

Lime shall be applied at 10 ton/acre.

5.2 FERTILIZER

Fertilizer rates given for REVEGETATION are for 1,000 lbs. of 10-20-20 per acre. These rates are minimum and for bidding purposes.

Fertilizer shall be applied evenly and uniformly distributed over the treated area. Common complete fertilizers which meet the minimum standards are acceptable.

5.3 MULCH

Acceptable mulch for this project is wood fiber, hay, or straw.

Mulch: Wood Fiber @ 1.0 ton/Acre

Hay or straw mulch may be substituted at a rate of 2 tons/Acre

WV-36a STATE OF WEST VIRGINIA
 Rev. 1/29/02 PURCHASING CONTINUATION SHEET
 VENDOR:

5.4 VEGETATIVE SPECIES

Seeding rate required is for pure live seed (pls) in pounds per acre. The use of annuals or cover crops will not be considered for vegetative success.

NORTH MIX

<u>VEGETATIVE SPECIES</u> ¹	<u>RATE/ACRE</u> ¹
Orchard Grass	@ 15 lbs/acre
Birdsfoot Trefoil ²	@ 15 lbs/acre
Yellow Sweet Clover	@ 5 lbs/acre
Red Clover	@ 10 lbs/acre
Ky 31 Fescue	@ 15 lbs/acre
Foxtail Millet ³	@ 12 lbs/acre
Wheat or Rye ⁴	@ 50 lbs/acre

1. Seeding rate suggested is for pure live seed (pls) in pounds per acre.
2. Herbaceous legumes must be treated with the appropriate bacterium before seeding.
3. Spring mix.
4. Fall mix.

6.0 CONSTRUCTION STAKEOUT

This work shall consist of furnishing, placing, and maintaining construction layout stakes necessary for the proper execution of the work required under the Contract. The Contractor shall provide control points for initial layout of the work. These points will be placed in a location which future work will not effect the set points. These points will remain until the contract is completed. The DEP on-site inspector will have access to these points to verify the work as it is occurring. (Shall not exceed 5% of the total bid for this permit.)

A. MATERIALS

Wooden stakes and other marking materials as described herein.

B. CONSTRUCTION METHODS

B(1). The Contractor shall provide field forces and shall set all additional stakes needed, such as offset stakes, reference point stakes, stakes for roadway drainage, sub-drains, fence, culverts or other structures, and any other horizontal or vertical controls necessary to secure a correct layout of the work.

B(2). Elevation control hubs with guard stakes shall be set, at a convenient distance outside the construction limits. The centerline station, the distance from centerline, and the elevation of the hub shall be recorded on each guard stake.

B(3). The Contractor shall be responsible for having the layout staking work conform to the lines, grades, elevations, and dimensions called for on the Plans. The Contractor shall be responsible for reporting any discrepancies to the Supervisor for clarification. Minor adjustments to suit field conditions are anticipated

BUYER CB-23	PAGE 019	REQ. OR PO NO. DEP 14149
SPENDING UNIT WEST VIRGINIA DEPARTMENT OF ENVIRONMENTAL PROTECTION/SPECIAL RECLAMATION		

WV-36a STATE OF WEST VIRGINIA
Rev. 1/29/02 PURCHASING CONTINUATION SHEET
VENDOR:

and it shall be the responsibility of the Supervisor to make decisions regarding adjustments.

B(4). Any inspection or checking of the Contractor's layout by the Supervisor and the acceptance of all or any part of it shall not relieve the Contractor of his responsibility to secure the proper dimensions, grades and elevations of the required work.

7.0 CONSTRUCTED SEDIMENT CONTROL SUMPS

Sediment control sumps shall be constructed as per attached detailed plans. Such structures shall be cleaned out when the sediment capacity reaches 60%, repaired, and maintained until demobilization. Clean-out and maintenance shall be conducted by the contractor at no expense to DEP. Each sump shall be approximately 6 feet wide by 12 feet long and 4 feet deep. The sump location shall be determined by the DEP onsite representative. The sumps shall be in the flow line of the constructed Riprap V-Ditch. The sides slopes of the sumps shall have riprap added upon completion of the project. This item will be a one-time payment for each one installed.

8.0 HAYBALE DIKE

Disturbed areas which have storm water runoff which does not pass through a sediment control structure shall utilize the following method to manage storm water runoff: Max. Bid of \$5.00/LF of Hay Bale Dike.

1. All bales shall be placed on the contour.
2. Bales shall be placed in a row with ends tightly abutting the adjacent bales.
3. Bales shall be securely anchored in place by stakes or rebars driven through the bales. Rebar to be removed at the direction of DEP. The first stake in each bale shall be driven toward previously laid bale to force the bales together. Construction of sediment control sumps (separate bid item) may become necessary to supplement the hay bale dikes.

9.0 HORIZONTAL BORING

The mine shall be dewatered by horizontal boreholes at the location shown on the plans and in accordance with the specifications and detail drawings. Prior to installing permanent mine drains, the existing mine pool shall be drained completely in a safe and controlled manner through two (2) 6-inch diameter pilot holes drilled from a boring pit to facilitate the horizontal drilling activities. The pilot hole shall be drilled about four (4) feet apart at the approximate alignment and grades shown on detail drawings. A drilling log shall be completed and kept at the site during all phases of the pilot hole installation. Depending on the drilling for the first pilot hole, the drilling of the second pilot hole may be altered as directed by the WVDEP.

The drilling site will require excavation to provide access for the drilling assembly. Measures must be employed to assure that site preparation is conducted in a safe manner. All appropriate accessories for the drill to function properly including motor controls and hoses shall be properly installed and provided with safety measures to prevent hazards to all persons who may visit the site. All material common to the operation must be stored and maintained properly.

The mine workings to be dewatered were located by test borings. The existing borings may be used as a guide to intercept the mine workings. Since the exact location of the mine workings was not identified, extra footage has been included in the bid item for pilot hole drilling. The Contractor will then have more than one opportunity to intercept the mine workings. There are two piezometers that may be used for monitoring the mine water level. The Contractor shall monitor the water level within the mine and perform the dewatering work in the safest manner possible. Any damages due to improperly controlled flows from the proposed boring shall be the sole responsibility of the Contractor. The Contractor will be required to submit surveying information, proposed hole alignment and other relevant information to the WVDEP for approval before drilling.

Pilot holes for dewatering the mine pool shall be drilled through proper standpipe casing and valves so that once the pilot holes encounter water, the outflow can be controlled and/or, if required, can be shut off. Adequate

BUYER CB-23	PAGE 020	REQ. OR PO NO. DEP 14149
SPENDING UNIT WEST VIRGINIA DEPARTMENT OF ENVIRONMENTAL PROTECTION/SPECIAL RECLAMATION		

WV-36a STATE OF WEST VIRGINIA
 Rev. 1/29/02 PURCHASING CONTINUATION SHEET
 VENDOR:

pipng is to be installed, or other arrangements shall be made that are previously approved by the WVDEP, so that water discharging from the pilot holes can be safely drained and the boring pit can be maintained relatively dry, and soil erosion can be minimized. The outlet for discharge shall be located downslope of the boring pit into a newly constructed mine drain pipes and settling pond as shown on the plans.

The Contractor shall use a self-leveling laser or similar instrument to check the line and grade elevation during drilling operations. At every 20 feet of drilling advancement, and at the beginning of each work shift, the Contractor shall remove the drilling tool from the hole, "defog" the casing pipe and check the line and grade elevation. If misalignment occurs during the operations, the Contractor shall be responsible for abandoning the hole, backfilling and sealing the misaligned hole with grout, and drilling a new hole at the desired alignment and grade. No payment shall be made for a misaligned hole.

Advancement of the pilot holes (and subsequent construction of the permanent mine drains) beyond the limits shown on the plans may be required if significant water volumes are not encountered. Following the completion of the pilot hole drilling, the Contractor shall allow the existing mine pool to drain while periodically measuring the mine pool elevation through the two piezometers. Discharged mine water shall be tested for pH throughout the dewatering process and may have to be treated with soda ash briquettes. A mine water neutralization system shall be constructed as necessary and the discharge treated in accordance with the Water Treatment Bid item.

All excess material generated by the work involved in this section may have to be placed into a temporary or permanent waste area within the construction limits. There are disposal areas identified within the construction limits for this project. On-site waste areas must be approved by the WVDEP.

After the existing mine pool is drained, the Contractor shall enlarge the pilot holes by reaming to sufficient diameter so that 16-inch diameter steel casing can be installed. Pipe sections shall be welded together as drilling advances. The pipe shall be perforated with 2-inch diameter holes on the inlet end for a minimum of 20 feet and/or as determined by the WVDEP from information obtained from the pilot hole drill log.

Permanent 12-inch diameter HDPE SDR11 drain pipes shall be installed inside the 16-inch steel casing as directed by the WVDEP. The void space between the 16-inch diameter casing and the 12-inch HDPE pipe shall be pressure cement grouted. The grout shall begin at the pit end of the casing for a minimum of 20 feet to ensure an adequate seal to prevent mine water seepage.

The permanent 12-inch HDPE SDR 11 mine drain at its inlet end shall be provided with stainless steel rod guards to prevent entry of obstructions into the mine drain. A minimum of 20 feet of the 12 inch pipe shall be perforated (1 inch diameter holes) and shall extend into the mine void area beyond the 16-inch steel casing.

Trenches and excavation for the boring pit exceeding 5 feet in depth shall be adequately supported with suitable temporary shoring/bracing or other means, with all trenching and excavation activities being performed in accordance with OSHA Regulations 29 CFR Part 1926 and as approved by the WVDEP, to prevent caving, slipping or cracking of the sides and to protect workmen from injury. Any temporary shoring installed shall be removed promptly following backfilling of the trench and excavation. It shall be the responsibility of the Contractor to design the shoring or other means of supporting the trench and excavation sides to prevent failure. Excavation stability and safety, as with all other safety aspects of this project, are the Contractor's responsibility, with the WVDEP and WVDEP Engineer accepting no responsibility or liability for damages or injuries arising from the work described herein.

At the completion of the dewatering system installation, the pit area material shall be replaced in compacted lifts with no lift exceeding six (6) inches. The entire width of each 6" lift shall be compacted with an overlapping pattern. If necessary, compaction equipment (vibratory roller, sheep's foot roller, etc.) may be used to help secure a solid area, which will not slip or allow seepage of the mine water. All stones exceeding 6 inches shall be removed from the embankment material prior to being placed. Also, any organic material (tree limbs, roots, top soil, etc.) shall be removed from embankment material prior to compaction. Weak or compressible areas, which cannot be satisfactorily compacted, shall be removed and replaced with properly compacted fill material. During dry conditions, water may need to be added to the fill material during the placement process to achieve optimum compaction. If the fill material is over saturated with water, the material may need to be spread and aerated prior to placement at the fill site for compaction.

BUYER CB-23	PAGE 021	REQ. OR PO NO. DEP 14149
SPENDING UNIT		
WEST VIRGINIA DEPARTMENT OF ENVIRONMENTAL PROTECTION/SPECIAL RECLAMATION		

WV-36a STATE OF WEST VIRGINIA
Rev. 1/29/02 PURCHASING CONTINUATION SHEET
VENDOR:

Backfill material shall be suitable on-site or off-site material which is dry to damp and free of organic material. Any material planned for use as backfill material shall be approved by the WVDEP before use. If off-site material is utilized, the Contractor will be required to obtain an agreement from the borrow area landowner.

All remaining disturbed areas shall be regraded as directed by the WVDEP, including the drilling access area, waste areas and revegetated in accordance with the Revegetation bid item.

9.1 BORING PIT EXCAVATION

This item shall include the removal of material needed to set up the drilling rig on the proper elevation to horizontally drill into the deep mine void area for dewatering, as indicated in the attached drawings. Also, proper replacement of the material in compacted lifts shall be required to prevent any slippage or allow any seepage of mine water, as indicated in the Horizontal Boring bid item.

Sloping and benching for the pit excavation shall be performed in accordance with OSHA Regulations 29 CFR Part 1926 Subpart P App B and as approved by the WVDEP, to prevent caving, slipping or cracking of the sides and to protect workmen from injury. Consider the soil classification to be Type C soil which requires side slopes to be 1 ½ to 1 H:V maximum allowable. Due to the excavation site in backfill material with partial mine water saturation, plan to slope the sides at 2 H: 1V. The site may have to be over excavated to meet OSHA standards on maximum depth of excavation. The contractor is responsible to have any approved excavation plans, if needed.

9.2 PILOT HOLES

The method of measurement for installation of "Pilot Holes" shall be per the linear foot, properly installed. This shall include the cost of furnishing all labor, materials, tools and equipment required for installing the holes, removing all cuttings and maintaining the holes open and clean until enlarged under the Double 12 -Inch Mine Drains bid item. The basis of payment for "Pilot Holes" shall be per linear foot, properly installed. The linear foot price shall include full compensation for all labor, drilling equipment, materials and incidentals necessary to complete the work. The 1440 LF includes enough length for four (4) separate attempts to hit the mine void, and only two (2) are required.

9.3 DOUBLE 12-INCH DIAMETER MINE DRAINS

The method of measurement for installation of "Double 12-inch Diameter Mine Drains" shall be per the linear foot, properly installed. This shall include the cost of furnishing all labor, materials, tools and equipment required for installing the drains, including the removal and disposal of all cuttings, proper installation of the 16-inch diameter casing, 12-inch diameter HDPE SDR 11 pipe, and all incidental work connected. The basis of payment for "Double 12-inch Diameter Mine Drains" shall be per the linear foot of two (2) casings and drain pipes, properly installed. Said linear foot price shall include full compensation for all labor, drilling, pipe, equipment, materials and incidentals necessary to complete the work.

10.0 DOUBLE 12-INCH HDPE PIPE

Pipe shall be twelve (12) inch diameter, SDR 11 HDPE of standard manufacture. Install to manufacturers recommendations. Location of the pipe installation will be determined during construction by the DEP on site representative. The "Double 12-inch HDPE Pipe" will convey the mine drainage water from the boring pit location to the "Constructed Settling Pond".

Provide all materials, equipment and personnel necessary for installation. Pipe shall be buried at least 2.5 ft. deep. Use butt fusion process to join pipes. A qualified fusion technician shall supervise the fusion of all joints.

The "Double 12-inch HDPE pipe" will be back filled according to the detail drawing and specifications. The two (2) 12-inch HDPE pipes will be installed with a 12 inch separation in a minimum four (4) feet wide trench. There will also be a minimum of 6 inches of stone on the bottom of the pipe and 18 inches above the pipes. There will be R-3 (3"-6") non calcareous stone placed around the HDPE pipe and cover the top of the stone with approved filter fabric. The three feet depth of stone shall transfer any water encountered in the trench from the backfill before the earthen material is layered and compacted over the pipes to the finished grade elevation. The pipes and water

BUYER CB-23	PAGE 022	REQ. OR PO NO. DEP 14149
SPENDING UNIT WEST VIRGINIA DEPARTMENT OF ENVIRONMENTAL PROTECTION/SPECIAL RECLAMATION		

WV-36a STATE OF WEST VIRGINIA
 Rev. 1/29/02 PURCHASING CONTINUATION SHEET
 VENDOR:

carried in the trench shall exit into the new settling pond. The pipes shall have animal guards installed on the exit end and shall be incidental to this bid item. Payment shall be per linear foot of dual pipe, stone, and fabric installed.

11.0 WYES (12" HDPE, LATERAL 45°)

Wyes shall be of standard manufacture for twelve inch diameter HDPE pipe (to allow 45° junction). Payment shall be for each wye installed. Use butt weld fusion process to join fittings to pipes. A qualified fusion technician shall supervise the fusion of all joints. The end of the HDPE 12 inch diameter pipe shall be fitted with a flange and blank end (separate bid item) above ground surface for cleanout purposes.

12.0 FLANGE (12 INCH HDPE)

On the end of the 12 inch HDPE line from the Wye, a flange with a stainless steel backer ring, bolts and nuts, and a blank end shall extend above the ground surface as a cleanout for the mine pipe. Use butt weld fusion process to join fittings to pipes. A qualified fusion technician shall supervise the fusion of all joints. Payment shall be for each location installed. Install posts or pipes to protect outlet from damage. All items shall be incidental to this bid item.

13.0 RIPRAP V-DITCH

Provide all materials, excavate and construct Ditch as indicated on the attached typical plans, cross-section, specifications, and/or discussions at the Pre-Bid Showing. Ditch shall be free draining and impervious upon completion of construction. Length of ditch may be adjusted to meet site conditions. Payment shall be for completed length of ditch. Limestone riprap R-4 shall be utilized at a thickness of 1.0 ft.

14.0 HDPE CULVERT 12 INCH DIAMETER

The culvert shall be HDPE, dual wall smooth interior corrugated twenty (20) foot joint type. The pipe joints shall be silt-tight and the pipe shall meet ASTM D3350 manufacturing standards. The culvert locations shall be determined by the onsite DEP representative.

Culverts installed in access roads shall cross the road at a 30 degree angle downgrade with a minimum grade of three percent (3%) from inlet to outlet, except in streams or diversion ditches where the pipe shall be installed straight and coincide with the normal direction of flow.

The culvert inlet and outlet ends shall be protected by a headwall of stable non-erodible material and the slope at the outlet shall be protected with an apron of rock riprap, energy dissipater or other designated material. The culvert shall be installed in a trench excavated in solid undisturbed ground or formed by compacted earth.

The culvert shall be imbedded in a formed trench to a depth no less than 1/10 the outside diameter of the pipe. Selected backfill material shall be placed around the culvert in four (4) inch layers and thoroughly compacted by means of hand tamping or manually directed power tampers or plate vibrators.

The culvert shall be covered with a minimum of twelve (12) inches of material. Payment shall be for length of culvert installed.

15.0 HDPE CULVERT 24 INCH DIAMETER

The culvert shall be HDPE, dual wall smooth interior corrugated twenty (20) foot joint type. The pipe joints shall be silt-tight and the pipe shall meet ASTM D3350 manufacturing standards. The culvert locations shall be determined by the onsite DEP representative.

Culverts installed in access roads shall cross the road at a 30 degree angle downgrade with a minimum grade of three percent (3%) from inlet to outlet, except in streams or diversion ditches where the pipe shall be installed straight and coincide with the normal direction of flow.

The culvert inlet and outlet ends shall be protected by a headwall of stable non-erodible material and the slope at the outlet shall be protected with an apron of rock riprap, energy dissipater or other designated material. The culvert shall be installed in a trench excavated in solid undisturbed ground or formed by compacted earth.

The culvert shall be imbedded in a formed trench to a depth no less than 1/10 the outside diameter of the

BUYER CB-23	PAGE 023	REQ. OR PO NO. DEP 14149
SPENDING UNIT WEST VIRGINIA DEPARTMENT OF ENVIRONMENTAL PROTECTION/SPECIAL RECLAMATION		

WV-36a STATE OF WEST VIRGINIA
 Rev. 1/29/02 PURCHASING CONTINUATION SHEET
 VENDOR:

pipe. Selected backfill material shall be placed around the culvert in four (4) inch layers and thoroughly compacted by means of hand tamping or manually directed power tampers or plate vibrators. The culvert shall be covered with a minimum of twelve (12) inches of material. Payment shall be for length of culvert installed.

16.0 STRUCTURE AND/OR DEBRIS REMOVAL

All existing man-made items particular to the site and not to be utilized in the total reclamation of this site shall be demolished (if necessary) and disposed of in a legal manner. All iron, steel, aluminum, or any other metal, plastic, or any other man made material, including but not limited to I-Beams, Angle Iron, Channel Iron, Corrugated Metal, Flat Metal, Floc Drums, Grease Drums, Pipe or Conduit is to be dismantled, removed and properly disposed of off site and according to state, local, and federal requirements. These structures are identified as: metal drums, scrap metal and general trash along work area.

17.0 CONSTRUCT SETTLING POND

One settling pond shall be constructed. The pond shall have a top width of approximately forty (40) feet, a top length of eighty (80) feet and a total excavation volume of approximately 790 cubic yards. The pond shall have a water depth of approximately 8 ft. with 2 ft. of freeboard. Side slopes shall be one horizontal to one vertical (1h:1v).

The settling pond is a lump sum bid item. The settling pond inlet and outlet spillways shall be paid for under the Riprap V-Ditch bid item, and shall be trapezoidal in shape instead of a V-ditch. Payment for this item is lump sum at the completion of this work.

EMBANKMENT CONSTRUCTION

Embankments shall be constructed in compacted lifts with no lift exceeding six (6) inches. The entire width of each 6" lift shall be compacted with an overlapping pattern. If necessary, compaction equipment (vibratory roller, sheep's foot roller, etc.) may be used to help secure a solid embankment, which will not slip or allow seepage of the ponded water. The base of any fill areas shall be undercut to solid material, and benched or keyed into the existing bank. All stones exceeding 6 inches shall be removed from the embankment material prior to being placed. Also, any organic material (tree limbs, roots, top soil, etc.) shall be removed from embankment material prior to compaction. Weak or compressible areas, which cannot be satisfactorily compacted, shall be removed and replaced with properly compacted fill material. During dry conditions, water may need to be added to the fill material during the placement process to achieve optimum compaction. If the fill material is over saturated with water, the material may need to be spread and aerated prior to placement at the fill site for compaction. The top pond berm width shall be a minimum of 12.0 feet. During construction if the above mentioned compaction equipment is not utilized, the top berm may need to be wider than 12.0 feet (20 feet wide) to accommodate multiple dozer passes and overlapping tracking to obtain compaction across the entire top width of pond berm. After appropriate compaction of material is achieved, the embankment slopes may be cut back to a 12.0 feet top width.

18.0 WATER TREATMENT

Water from the impounded deep mine works shall be analyzed and treated before entering a settling pond and discharge to receiving waters of the state. Treat to a pH between 6 and 9, or to the minimum pH of the receiving stream (whichever is greater.)

19.0 CLEAR AND GRUB

All vegetative cover (trees, shrubs, bushes etc.) within the entire work area shall be removed to bare ground. It is the contractor's responsibility to obtain all necessary permits and to follow state guidelines for burning and proper disposal of vegetative materials. Disposal of the trees and shrubs on-site with a chipper is an acceptable alternative to burning. Any timber cut in the clear and grub area that the landowner wishes to retain shall be de-limbed and stockpiled.

BUYER CB-23	PAGE 024	REQ. OR PO NO. DEP 14149
SPENDING UNIT WEST VIRGINIA DEPARTMENT OF ENVIRONMENTAL PROTECTION/SPECIAL RECLAMATION		

WV-36a STATE OF WEST VIRGINIA
Rev. 1/29/02 PURCHASING CONTINUATION SHEET
VENDOR:

20.0 BAFFLE CURTAIN

The baffle curtain shall be of an ultraviolet (UV) resistant type vinyl coated polyester material with a minimum total weight rating of 17 oz./sq. yd. Styrofoam floats of minimum size 3"x4"x24" shall be hot seam sealed into the top of baffle curtain, and shall be evenly spaced 4 inches apart end to end. A grommet shall be placed between each of the styrofoam floats. A 5/16 inch diameter stainless steel wire cable shall be seamed into the top of the baffle to anchor at the sides of the pond. The cable and bottom chain shall extend 10 feet past the cut length of the baffle curtain on each end. A 1/4 inch diameter link chain shall be hot seam sealed into the bottom of the baffle for weight, and to anchor at the sides of the pond. Chain shall be bolted at each end through the top hot seam to create another anchor point for the curtain. Secure anchor points (pipe, rods, or treated posts) shall be installed at the ponds edge to hold the baffle in place. Anchor points and the baffle location shall be approved by the DEP onsite representative before installation. The wire cable and chain shall be attached in such a way to allow for easy disconnect while sludge is being pumped from the pond. All cable fasteners, eye bolts, and other accessories shall be stainless steel to prevent corrosion, and shall be incidental to this pay item. The baffle curtain opening slots shall be cut into the curtain below the hot seam seal at the top of the baffle, as indicated on the attached drawing. The spacing and the size of the slots shall be determined by the DEP engineer or onsite representative, and shall be installed at the time of installation. Payment shall be lump sum, and shall include all posts, anchors, fasteners, chain, and cable required to secure baffles in place. Baffle curtains shall be installed at one location. The approximate total length of curtain is 41 linear feet.

BUYER CB-23	PAGE 025	REQ. OR PO NO. DEP 14149
SPENDING UNIT WEST VIRGINIA DEPARTMENT OF ENVIRONMENTAL PROTECTION/SPECIAL RECLAMATION		

WV-36a STATE OF WEST VIRGINIA
 Rev. 1/29/02 PURCHASING CONTINUATION SHEET
 VENDOR:

BID PREPARATION INFORMATION

HISTORICAL INFORMATION

Prospective bidders may review files at the West Virginia Department of Environmental Protection, Charleston, WV office, or the Regional West Virginia Department of Environmental Protection Office at 105 South Railroad St., Philippi, WV 26416. These files may contain additional information not included in the contract. Documents including, but not limited to, permit applications, permits, inspection reports, environmental documents, permit violation history, geological and geotechnical information, probable hydrologic consequences, maps, modifications, NPDES information and other related data. Copies may be obtained upon request and payment of copying fees.

EXAMINATION OF BID PACKAGE AND SITE OF WORK

The bidder is required to examine, carefully, the bid package (plans, specifications, supplemental specifications, contract forms, etc.) and the site of the work contemplated. The submission of a bid shall be considered prima facie evidence that the bidder has made such examination and has judged for and satisfied themselves as to the character, quantity, and quality of work to be performed and the materials required to be furnished under the contract.

PREBID CONFERENCE

Only the prospective bidders on the sign-in sheet in attendance for the entire Pre-Bid Conference will be eligible to submit bids for consideration of this project.

VIDEO

The information given at the pre-bid showing by the project contact person or the assigned person shall be documented on video tape and shall be an integral part of this contract's requirements, but will not supersede the written contract.

INTENT OF CONTRACT

The intent of the contract is for the reclamation/restoration of forfeited mine lands as required by West Virginia Department of Environmental Protection. The contractor is to provide for the construction and completion in every detail of the work described. The Contractor shall furnish all labor, materials, equipment, tools, transportation, and supplies required to complete the work in accordance with the Plans, Specifications, and terms of the Contract.

Should any misunderstanding arise as to the intent or meaning of the Contract, or any discrepancy appear, the decision of the Director of Division of Land Restoration shall be final.

BUYER CB-23	PAGE 026	REQ. OR PO NO. DEP 14149
SPENDING UNIT WEST VIRGINIA DEPARTMENT OF ENVIRONMENTAL PROTECTION/SPECIAL RECLAMATION		

WV-36a STATE OF WEST VIRGINIA
 Rev. 1/29/02 PURCHASING CONTINUATION SHEET
 VENDOR:

GENERAL PERFORMANCE STANDARDS

INTRODUCTION

The performance standards and non-compliance penalties which govern special reclamation-bond forfeiture projects are in Chapter 22A, Article 3, of the Code of West Virginia and subsequent rules and regulations. The following performance standards are of a general nature and do not represent all the performance standards applicable to a special reclamation-bond forfeiture project. However, some or all of these standards will pertain to each project.

BACKFILLING

1. Unless otherwise noted, the highwall shall be eliminated and the disturbed area graded to the approximate original contour.
2. The material used to backfill and eliminate the highwall shall be sufficiently compacted so as to insure stability of the backfill throughout the warranty period.
3. The land above the highwall shall not be disturbed unless otherwise directed.
4. The best available material to support vegetation, sufficient to establish a permanent vegetative cover and to achieve the approved post mining land use, shall be used.

BLASTING

The performance standards of the blasting regulations must be adhered to.

LIFE OF CONTRACT

The purchase order contract becomes effective on the starting date as specified in the notice to proceed as issued by the Department of Environmental Protection. This contract extends for a period of one (1) year and may be renewed until such "reasonable time" thereafter as is necessary to complete the payment therefore. A responsible Contractor's Agent shall be on the site at all working times who demonstrates a knowledge of mined land reclamation, contract requirements and responds to DEP (owner) inspections.

WORK PERFORMANCE PERIOD

The work performance period is a defined portion of the contract in which all items shall be completed. The work performance period is to be performed within 365 calendar days. Extensions may be granted based upon contractor's performance, weather conditions and site-specific site conditions.

NOTICE TO PROCEED

A notice to proceed shall be issued to the Contractor by the project contact person for the Department of Environmental Protection. Actual construction may only begin after a Notice to Proceed is given and as specified. Such notice shall specify the starting date of the Purchase Order, the work performance period, and the completion date of the work performance period.

PRE-CONSTRUCTION CONFERENCE

The Contractor in possession of the awarded purchase order shall schedule a Pre-Construction Conference on the site within ten (10) days after receiving the Notice To Proceed. The Contractor's foreman or the on-the-ground supervisor must be in attendance.

BUYER CB-23	PAGE 027	REQ. OR PO NO. DEP 14149
SPENDING UNIT WEST VIRGINIA DEPARTMENT OF ENVIRONMENTAL PROTECTION/SPECIAL RECLAMATION		

WV-36a STATE OF WEST VIRGINIA
Rev. 1/29/02 PURCHASING CONTINUATION SHEET
VENDOR:

GENERAL SUPERVISION - This contract is under the general supervision of the West Virginia Department of Environmental Protection's contact person for the purpose of contract compliance inspection only. Contractor shall supervise work being conducted at all times. All services rendered by the Engineer/Contact Person consist of professional opinions and recommendations made in accordance with generally accepted engineering practice. Under no circumstances is it the intent of the Engineer/Contact Person to directly control the physical activities of the Contractor or the Contractor's workmen's accomplishment of work on this project.

CONTRACTOR RESPONSIBILITY

The contractor is responsible for compliance with all aspects of this written contract. No changes will be honored without prior approval from the Program Supervisor.

SILENCE OF SPECIFICATIONS

The apparent silence of these Specifications, Supplemental Specifications, plans and Special Provisions as to any detail, or the apparent omission from them of a detailed description concerning any point shall be regarded as meaning that only material and workmanship of acceptable quality are to be used.

LAWS TO BE OBSERVED

The Contractor shall keep fully informed of all Federal and State laws, all local laws, ordinances, and regulations and all orders and decrees of bodies or tribunals having any jurisdiction or authority, which in any manner affect those engaged or employed on the work, or which in any way affect the conduct of the work. The Contractor shall at all times observe and comply with all such laws, ordinances, regulations, orders and decrees; and shall protect and indemnify the State and its representatives against any claim or liability arising from or based on the violation of any such laws, ordinances, regulations, orders, or decrees, whether by themselves, their subcontractors or their employees.

PERMITS, LICENSES AND TAXES

The Contractor shall procure all permits and licenses, pay all charges, fees, and taxes, and give all notices necessary and incidental to the due and lawful prosecution of the work.

CONCURRENT RECLAMATION

Reclamation of this project shall commence at a definite point as defined and shall progress from that point with total reclamation to include backfilling, grading/regrading, and revegetation. Changes may be granted based upon weather or differing site conditions with prior approval.

WATER QUALITY CONTROL

Shall commence with initial start-up of the project and remain in effect for the extent of the backfilling, regrading and revegetation activity. DEP obtains a storm water permit for each project from the Water Resources Division. (General Water Pollution Control Permit WVO115924) The Contractor is responsible for performing the best management practices. Adequate facilities shall be installed, operated and maintained using the best management practices of the U.S. Environmental Protection Agency's Non-Point Source (NPS) Program for sediment control during the active reclamation. The contractor shall take any and all steps necessary to prevent erosion or silting problems from occurring and to minimize pollution or sedimentation of the stream. If any such problems develop, the contractor shall be responsible to take immediate corrective action. No separate payment for this work will be honored. All impounded waters which require removal during reclamation, shall be pumped with appropriate measures taken to prevent erosion from the discharge. The contractor shall be responsible for treatment of said waters to meet pH standards. The water shall be discharged only when the quality meets a pH equivalent to the pH of the receiving stream but not less than 6.0.

BUYER CB-23	PAGE 028	REQ. OR PO NO. DEP 14149
SPENDING UNIT WEST VIRGINIA DEPARTMENT OF ENVIRONMENTAL PROTECTION/SPECIAL RECLAMATION		

WV-36a STATE OF WEST VIRGINIA
 Rev. 1/29/02 PURCHASING CONTINUATION SHEET
 VENDOR:

DIFFERING SITE CONDITIONS

During the progress of the work, if subsurface or latent physical conditions are encountered at the site differing materially from those indicated in the contract or if unknown physical conditions of an unusual nature, differing materially from those ordinarily encountered and generally recognized as inherent in the work provided by the contract, are encountered at the site, the party discovering such conditions shall promptly notify the other party in writing of the specific differing conditions before they are disturbed and before the affected work is performed.

Upon written notification, the Engineer/Contact Person will investigate the conditions, and if determined that the conditions materially differ and cause an increase or decrease in the cost or time required for the performance of any work under the contract, an adjustment, excluding loss of anticipated profits, will be made and the contract modified in writing accordingly. The Engineer/Contact Person will notify the Contractor of DEP's determination whether or not an adjustment of the contract is warranted.

No contract adjustment which results in a benefit to the Contractor will be allowed unless the Contractor has provided the required written notice.

No contract adjustment will be allowed under this clause for any effects caused on unchanged work.

HANDLING AND STORAGE OF MATERIALS

Materials which are stored on site, before utilization, shall be stored so as to assure the preservation of their quality and fitness for the work. Stored materials, even though approved before storage, may be inspected again prior to their use in the work. Damaged or deteriorated materials shall be removed and replaced by materials meeting the original specifications.

Aggregate stockpiles shall be made on ground that is denuded of vegetation, hard, and well drained. Removal of aggregate from the stockpile shall be done in a manner which will not result in the inclusion of foreign material into the aggregate. The use of the aggregate will determine if exceptions are permitted.

All materials shall be handled in such a manner as to preserve their quality and fitness for the work.

MAINTENANCE DURING CONSTRUCTION

The contractor shall maintain the work during construction and until the project is accepted. All cost of maintenance work during construction and before the project is accepted shall be included in the unit or lump sum prices on the various pay items.

FINAL INSPECTION

A final inspection meeting by the Department of Environmental Protection's Specialist and the contractor is required for the construction phase and prior to demobilization.

ACREAGE QUANTITIES

The acreage quantities in this contract are for bidding purpose and are set (definite) number for the project area as specified at the pre-bid showing. Only surveyed acreage's through figures the Contractor and/or the State develops will be honored to alter these acreage numbers.

PAYMENT

Invoices must be submitted on prescribed Department of Environmental Protection, Special Reclamation Program forms and include verification. Certified contractor payrolls for operators directly involved in this project and a current workers compensation certificate must accompany each invoice for payment. Verification of wage rates may include employee interviews. Invoices shall be signed in blue ink so that it is easy to verify that document is an original.

MOBILIZATION/DEMobilIZATION shall be invoiced at fifty percent (50%) with the first invoice and the last 50% invoiced after demobilization and acceptance of the road abandonment or final invoice. Demobilization must have written approval.

BUYER CB-23	PAGE 029	REQ. OR PO NO. DEP 14149
SPENDING UNIT WEST VIRGINIA DEPARTMENT OF ENVIRONMENTAL PROTECTION/SPECIAL RECLAMATION		

WV-36a STATE OF WEST VIRGINIA
 Rev. 1/29/02 PURCHASING CONTINUATION SHEET
 VENDOR:

SPILL CONTAINMENT AREA shall not exceed \$1,000.00 and will be payable in two payments. The first fifty percent (50%) payable with the first invoice and the remainder payable when all fuel tanks, containers and etc., are removed from the site.

Lump sum items shall be percentage payments based on work completed at time of invoice and paid upon acceptance by the Department of Environmental Protection.

Unit items shall be invoiced by specified units completed and accepted by the DEP.

FAILURE TO COMPLETE ON TIME AND LIQUIDATED DAMAGES

Time is an essential element of the Contract and it is important that the work be completed within the time specified. The cost to the Department of the administration of the Contract, including engineering, inspection and supervision, will increase as the time required to complete the work is increased.

The work performance period as specified in the contract's Notice to Proceed shall be complied with or result in liquidated damages. Such damages shall be assessed at an amount of two hundred and fifty dollars (\$250.00) per day for each and every day beyond the work performance period as specified in the Notice to Proceed. The total amount of daily charges will be deducted from any moneys due the Contractor, not as a penalty but as liquidated damages.

REVEGETATION AND WARRANTY

The seeding date shall be at the discretion of the contractor once an approved seedbed has been prepared. In all cases a permanent vegetative cover capable of supporting the post-mining land use must be established. A warranty period of one (1) year shall commence upon completion and payment of the revegetation item of the contract. No payment will be made for additional seeding necessary to comply with warranty requirements. The warranty period will be extended for one (1) year from the date of the last augmented seeding done by the contractor. The performance bond and labor and materials bond shall remain in effect throughout the warranty period. The Standards for Evaluating Vegetative Cover as presented in Title 38, CSR2, Section 9 of the West Virginia Surface Mining Reclamation Regulations will apply.

Equipment for the retracking/scarification to eliminate rills and gullies shall be mobilized and utilized to produce slopes consistent with the regrading and topsoiling bid item prior to warranty reseeding. No additional payment will be made by DEP for this warranty work.

Water utilized for hydroseeding shall be free of injurious or other toxic substances harmful to plant life. The source of water is subject to the approval of the DEP contact person.

CONTRACT NON-COMPLIANCE

If in the opinion of the Department of Environmental Protection the contract is not in compliance with any line item specification, that portion of the project shall cease until a compliance schedule and understanding is demonstrated in writing and accepted by the Director of Division of Land Restoration.

CONTRACT DELETIONS

Any line item, or any portion thereof, may be deleted when determined by the project contact person that such line item, or portion thereof, is deemed unnecessary for the successful reclamation of this project. No claim for loss of anticipated profits will be considered.

CANCELLATION

The performance of work under contract may be terminated by the State in whole, or from time to time in part whenever the State shall determine that such termination is in the best interest of the State. Any such termination shall be effected by delivery to the Contractor of a Notice of Termination specifying the extent to which performance of work under the Contract is terminated and the date upon which such termination becomes effective.

BUYER CB-23	PAGE 030	REQ. OR PO NO. DEP 14149
SPENDING UNIT WEST VIRGINIA DEPARTMENT OF ENVIRONMENTAL PROTECTION/SPECIAL RECLAMATION		

WV-36a STATE OF WEST VIRGINIA
Rev. 1/29/02 PURCHASING CONTINUATION SHEET
VENDOR:

When contracts, or any portion thereof, are terminated before completion of all items of work in the Contract, payment will be made for the actual number of units or items of work completed and accepted at the contract unit price. No claim for loss of anticipated profits will be considered. Reimbursement for organization of the work, when not otherwise included in the Contract, and moving equipment to and from the job will be considered where the volume of work completed and accepted is too small to compensate the Contractor for these expenses under the contract unit prices, the intent being that an equitable settlement will be made with the Contractor.

Termination of the Contract or a portion thereof shall not relieve the Contractor of his responsibilities for the completed work, nor shall it relieve his surety of its obligation for and concerning any just claims arising out of the work performed.

This contract may be cancelled in whole or in part in writing by the Director of Purchasing, without prejudice to any other right or remedy it may have, provided that the contractor is given not less than thirty (30) calendar days written notice, (delivered by certified mail, return receipt requested) of intent to terminate. This contract objective is to comply with the reclamation laws of this state and must be expedient to meet the time requirements for reclamation of revoked surface mine permits.

BUYER CB-23	PAGE 031	REQ. OR PO NO. DEP 14149
SPENDING UNIT		
WEST VIRGINIA DEPARTMENT OF ENVIRONMENTAL PROTECTION/SPECIAL RECLAMATION		

WV-36a STATE OF WEST VIRGINIA
 Rev. 1/29/02 PURCHASING CONTINUATION SHEET
 VENDOR:

S

Attn:

Re: Notice to Proceed
 Permit Name: _____
 Permit No. _____
 Purchase Order No.: DEP

Dear :

The purpose of this letter is to express our appreciation for your work in advance and to recognize a reclamation partnership project. The official starting date for the above mentioned purchase order is . The work performance period must be completed by . The contract life of one year is provided to accomplish all line items and to process all payments within that period.

You must schedule a pre-construction conference on site within ten (10) days after receiving this notice to proceed. It is then mandatory that construction begins within ten (10) days of the pre-construction conference and continues diligently until completion of the project. Please contact this office to schedule the pre-construction conference. The foreman, superintendent, or on-the-ground supervisor must be in attendance at this conference.

Failure to comply with this notice to proceed will cause termination of the contract and forfeiture of your performance bond.

If you have any questions please feel free to contact this office.

L

Sincerely,

E

BUYER CB-23	PAGE 032	REQ. OR PO NO. DEP 14149
SPENDING UNIT WEST VIRGINIA DEPARTMENT OF ENVIRONMENTAL PROTECTION/SPECIAL RECLAMATION		

WV-36a STATE OF WEST VIRGINIA
Rev. 1/29/02 PURCHASING CONTINUATION SHEET
VENDOR:

General Requirements

Project Construction Sign

Work Required

The work to be performed under this Section consists of providing all labor, material and equipment necessary to install a project sign as indicated on the detail included herein and as specified herein.

Materials

- (a) Paint. Paint for the project sign shall be one (1) coat Exterior-Grade Wood Primer- Sealer, and two (2) coats Exterior-Grade Enamel by Glidden or equivalent.
- (b) Wood. Sign face shall be 3/4" X 4' X 8' Marine Exterior plywood, and posts and cross braces shall be treated.
- (c) Hardware. All hardware shall be manufactured from good, commercial-quality material and be rust resistant such as galvanized coated.

Execution

- (a) Project Sign. The signboard shall be cut to the dimensions shown on the details herein. The sign shall be painted with one (1) coat of primer and two (2) coats of white enamel. All exterior cut edges shall be smooth sanded prior to painting. All edges shall be double primed. The letters, border and strips shall be painted as shown on the detail drawing.

The Contractor shall bolt the sign to posts and provide required cross bracing. The posts and sign shall be erected and posts set in gravel base, as shown on the drawings. One (1) sign is required and is to be located at the direction of WVDEP.

- (b) Payment. Payment for the work which shall include installation of the project sign shall be incidental to the lump sum bid item for "Mobilization/Demobilization"

Note: No construction work shall commence prior to the project sign being installed.



STATE OF WEST VIRGINIA
DEPARTMENT OF ENVIRONMENTAL PROTECTION

Division of Land Restoration
Office of Special Reclamation

Joe Manchin, III
Governor



Stephanie Timmermeyer,
Cabinet Secretary



Ken Ellison,
Director

Project Cost: \$XXX,XXX.00
Funding provided by the Special Reclamation Coal Tax paid by WV Coal Mine Companies

Permit Name Permit Number	Project Start Date: 01/01/01
------------------------------	------------------------------

Contractor: Joe Smith Contracting

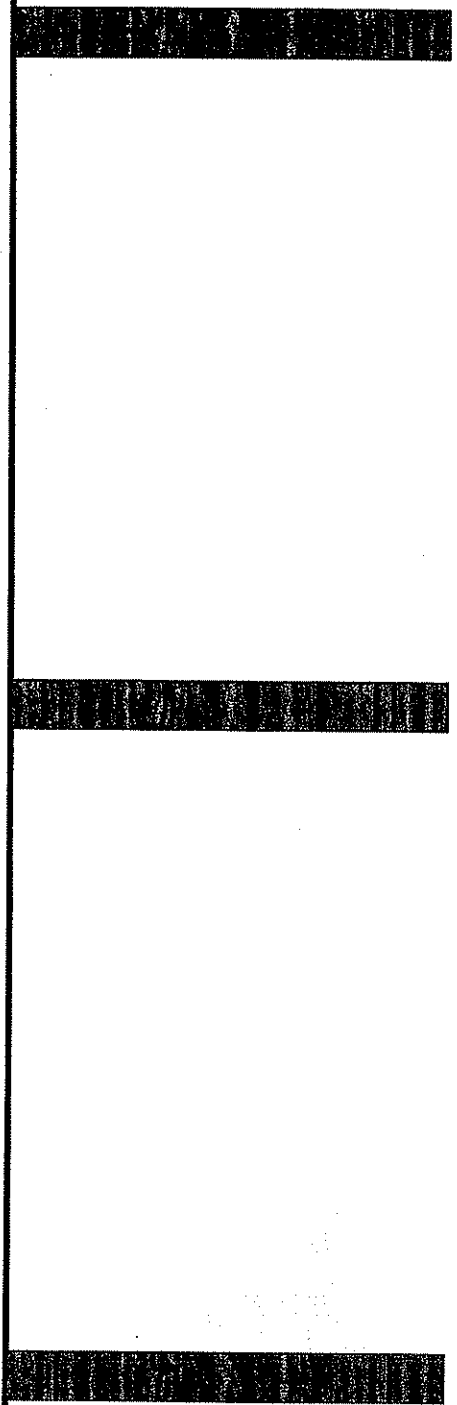

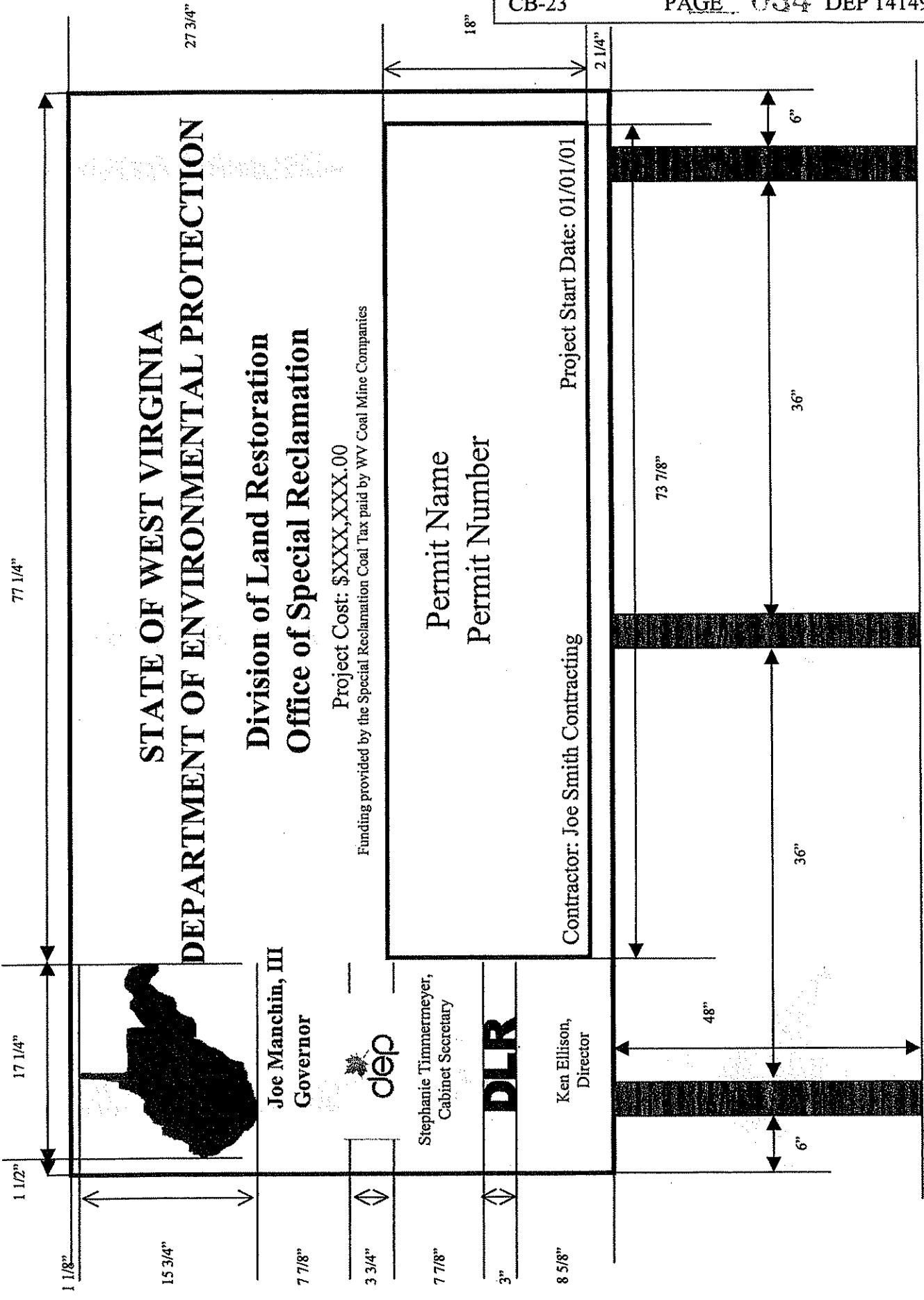

77 1/4"

27 3/4"

18"

2 1/4"

17 1/4"

1 1/2"

15 3/4"

7 7/8"

3 3/4"

7 7/8"

3"

8 5/8"

STATE OF WEST VIRGINIA
DEPARTMENT OF ENVIRONMENTAL PROTECTION

Division of Land Restoration
Office of Special Reclamation

Project Cost: \$XXX,XXX.00
 Funding provided by the Special Reclamation Coal Tax paid by WV Coal Mine Companies

Joe Manchin, III
 Governor



Stephanie Timmermeyer,
 Cabinet Secretary



Ken Ellison,
 Director

Permit Name
 Permit Number

Contractor: Joe Smith Contracting

Project Start Date: 01/01/01

73 7/8"

36"

36"

48"

6"

6"

96"



STATE OF WEST VIRGINIA
DEPARTMENT OF ENVIRONMENTAL PROTECTION

Division of Land Restoration
Office of Special Reclamation

Joe Manchin, III
Governor

48"

Project Cost: \$XXX,XXX.00
Funding provided by the Special Reclamation Coal Tax paid by WV Coal Mine Companies



Stephanie Timmermeyer,
Cabinet Secretary



Ken Ellison,
Director

Permit Name	Project Start Date: 01/01/01
Permit Number	
Contractor: Joe Smith Contracting	

7 7/8"

9 3/8"

81 3/8"

5 1/4"

6" 2 1/4" 1 1/4" 2 1/4" 3 3/4" 2 1/4" 1 1/4" 2 1/4" 3 3/4" 1 1/4" 4 7/8" 2 1/4" 1 1/4" 2 1/4" 4 7/8" 1 1/4" 3 3/4"

STATE OF WEST VIRGINIA
DEPARTMENT OF ENVIRONMENTAL PROTECTION

Division of Land Restoration
Office of Special Reclamation

Project Cost: \$XXX,XXX.00
 Funding provided by the Special Reclamation Coal Tax paid by WV Coal Mine Companies

Permit Name
 Permit Number

Contractor: Joe Smith Contracting
 Project Start Date: 01/01/01

17 1/2" 1 1/4" 3/4" 1 1/4" 9 1/4" 1" 3/4" 1" 8" 1" 3/4" 1" 3 3/4"



Joe Manchin, III
 Governor

 Stephanie Timmermeyer,
 Cabinet Secretary

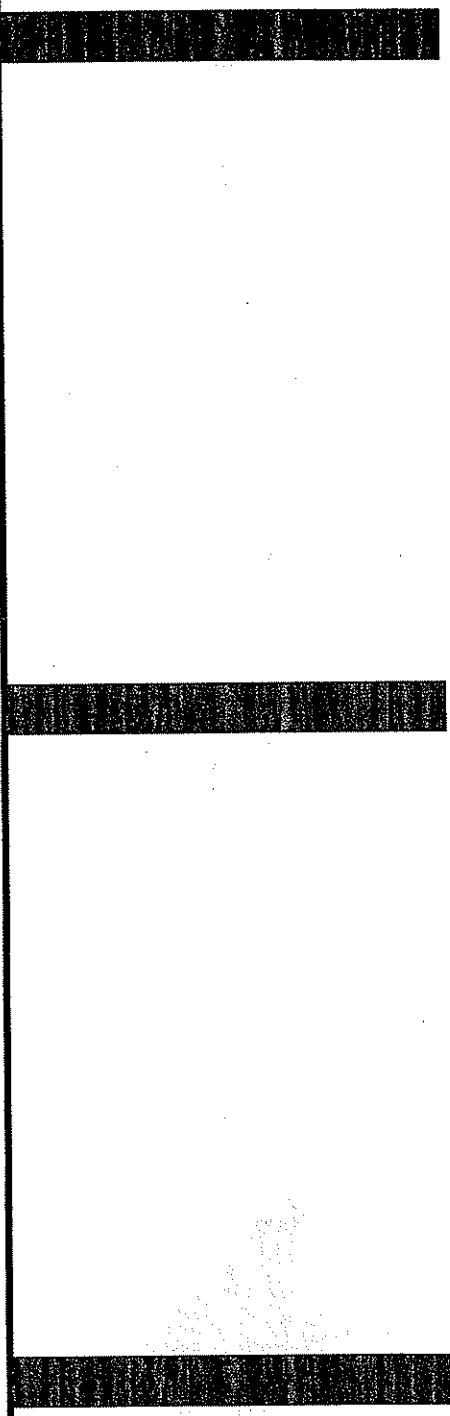
DLR
 Ken Ellison,
 Director

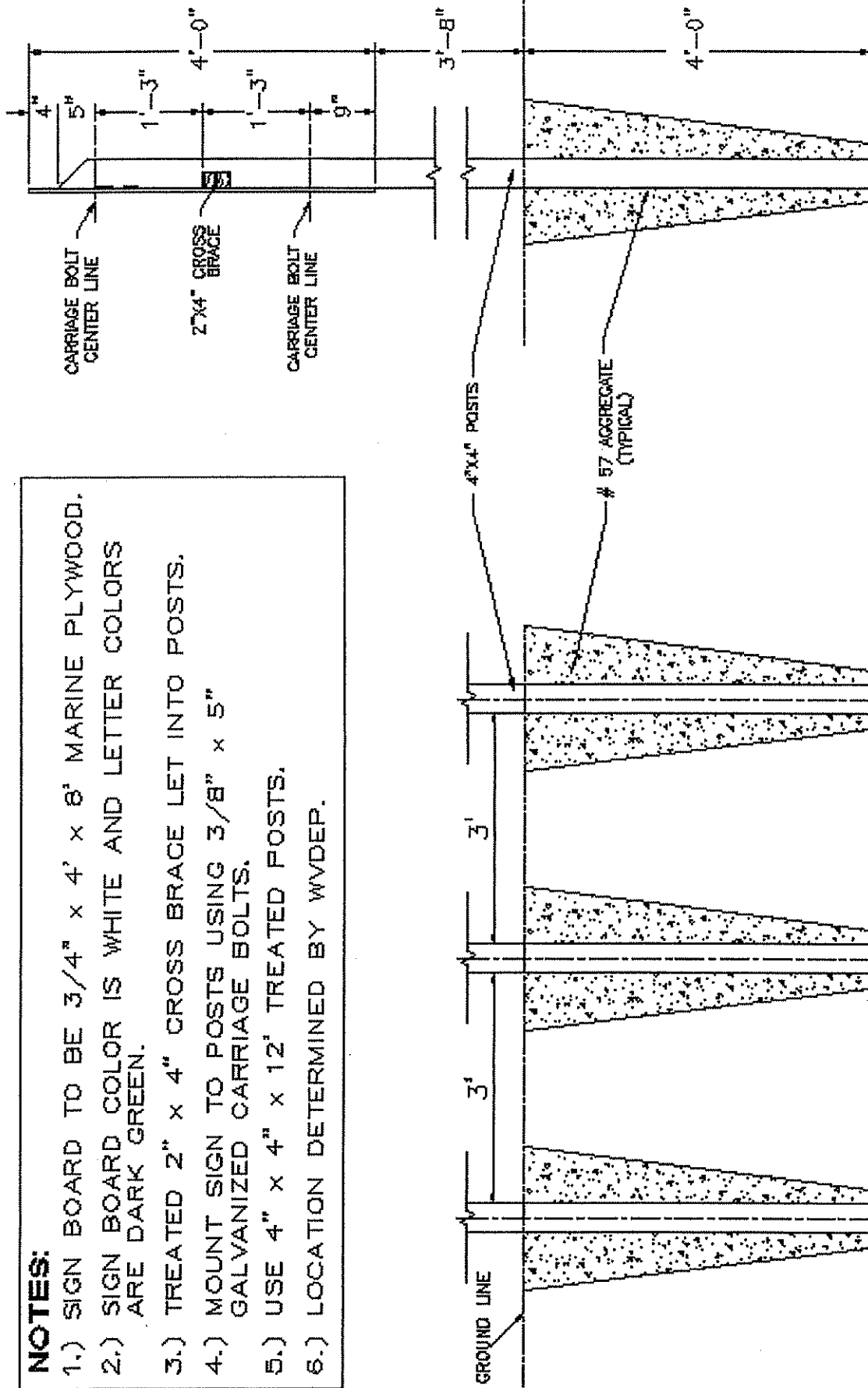

- NOTES:**
- 1.) SIGN BOARD TO BE 3/4" x 4' x 8' MARINE PLYWOOD.
 - 2.) SIGN BOARD COLOR IS WHITE AND LETTER COLORS ARE DARK GREEN.
 - 3.) TREATED 2" x 4" CROSS BRACE LET INTO POSTS.
 - 4.) MOUNT SIGN TO POSTS USING 3/8" x 5" GALVANIZED CARRIAGE BOLTS.
 - 5.) USE 4" x 4" x 12' TREATED POSTS.
 - 6.) LOCATION DETERMINED BY WVDEP.



PROJECT SIGN
NOT TO SCALE

FRUSH ENTERPRISES SITE

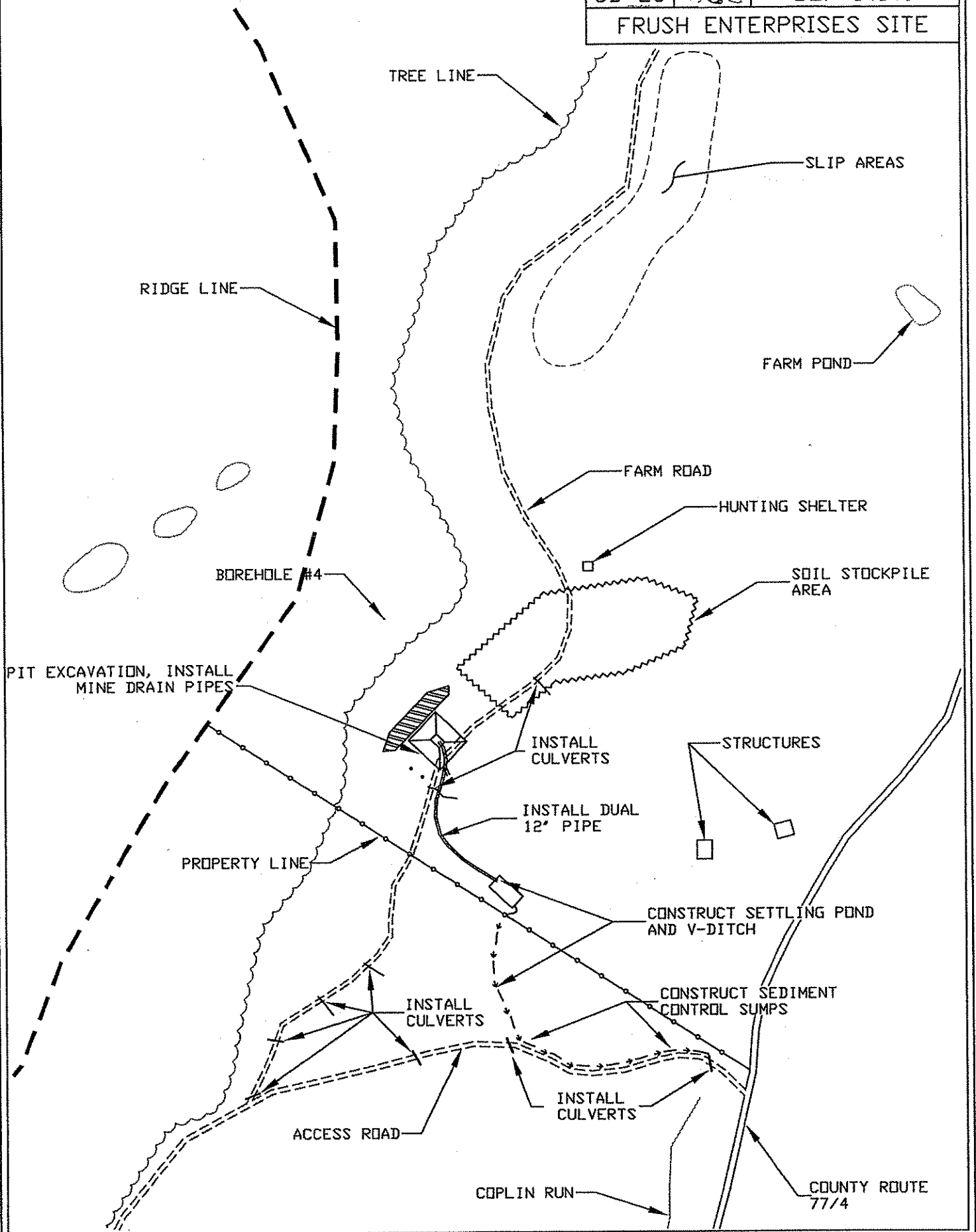

SPILL CONTAINMENT

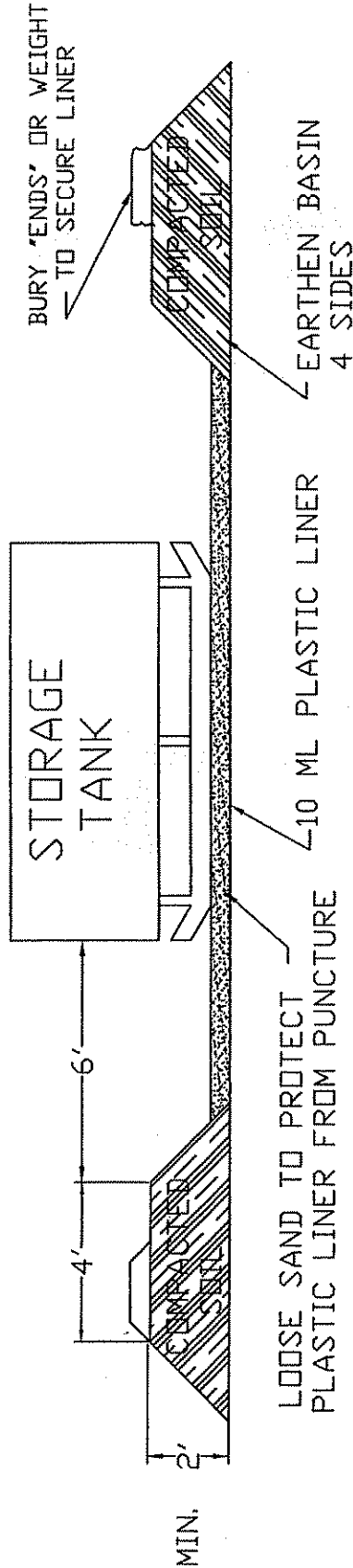

SELECTED HEIGHT OF EARTHEN BERM IS TO BE A TWO (2') FOOT MINIMUM OR ONE HUNDRED TEN PERCENT (110%) OF THE CAPACITY OF THE TANK(S) TOTAL VOLUME WITHIN THE BERM. A SIX (6") INCH FREEBOARD MUST BE INCLUDED.

NOTE: A TWO INCH (2") WATER REMOVAL DRAIN SHALL BE LOCATED AT THE LOWEST POINT IN THE BOTTOM OF THE CONTAINMENT VOLUME. IT SHALL CONNECT TO A NORMALLY CLOSED VALVE OUTSIDE THE DIKE. THE VALVE SHALL BE MANUALLY OPERATED AND PROTECTED FROM UNAUTHORIZED OPERATION. RAINWATER CONTAINED WITHIN THIS DIKE SHALL BE EXAMINED PRIOR TO RELEASE TO ENSURE THAT HARMFUL QUANTITIES OF FUELS AND LUBRICANTS ARE NOT DISCHARGED. ALTERNATE METHODS OF WATER REMOVAL WILL BE CONSIDERED FOR APPROVAL.

TANKS WITH SECONDARY CONTAINMENT MAY BE USED AS AN ALTERNATIVE.

STRAW/HAY BALE DIKE

2 REBAR, STEEL PICKETS, OR
2"x2" STAKERS PER BALE
DRIVEN 1' MIN. INTO GROUND

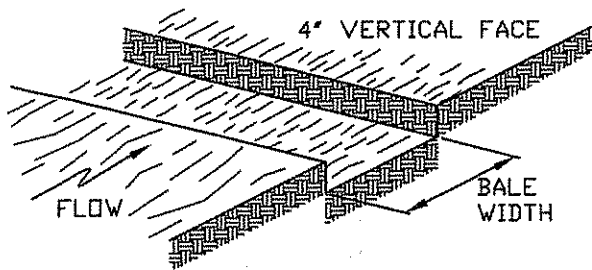

1. EXCAVATE THE TRENCH.

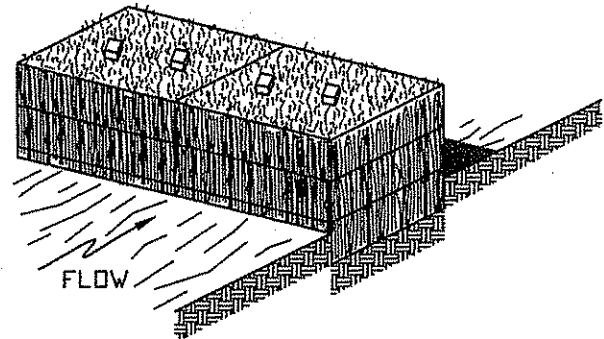

2. PLACE AND STAKE THE BALES.

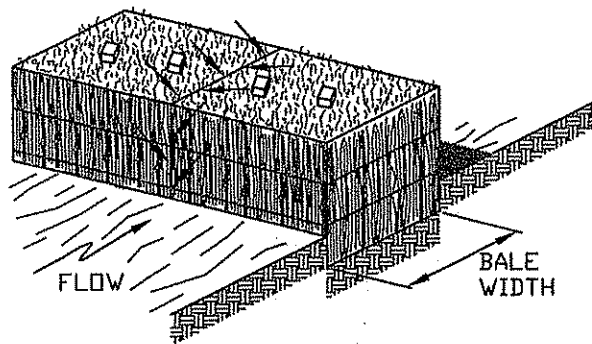

3. WEDGE LOOSE STRAW BETWEEN BALES.

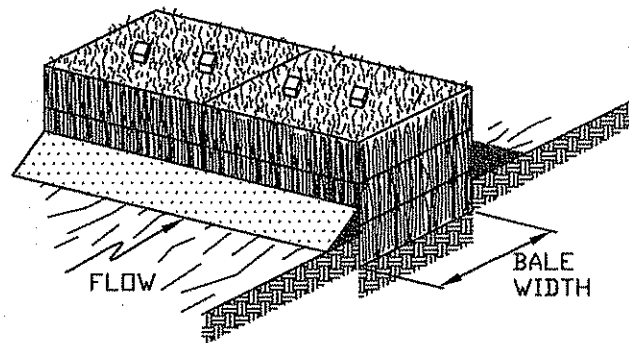

4. BACKFILL AND COMPACT THE EXCAVATED SOIL.

HAY OR STRAW BALE INSTALLATION SEQUENCE

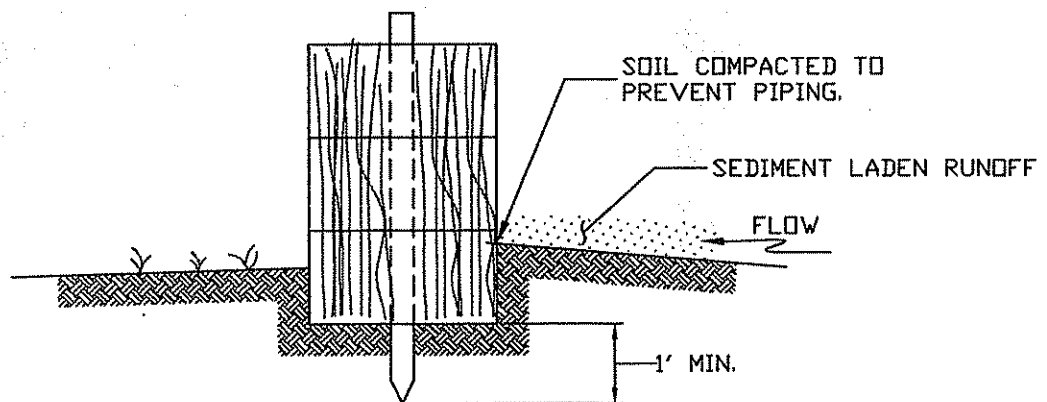

PROPERLY INSTALLED BALE

ACCESS ROAD UPGRADE

ACCESS ROAD UPGRADE

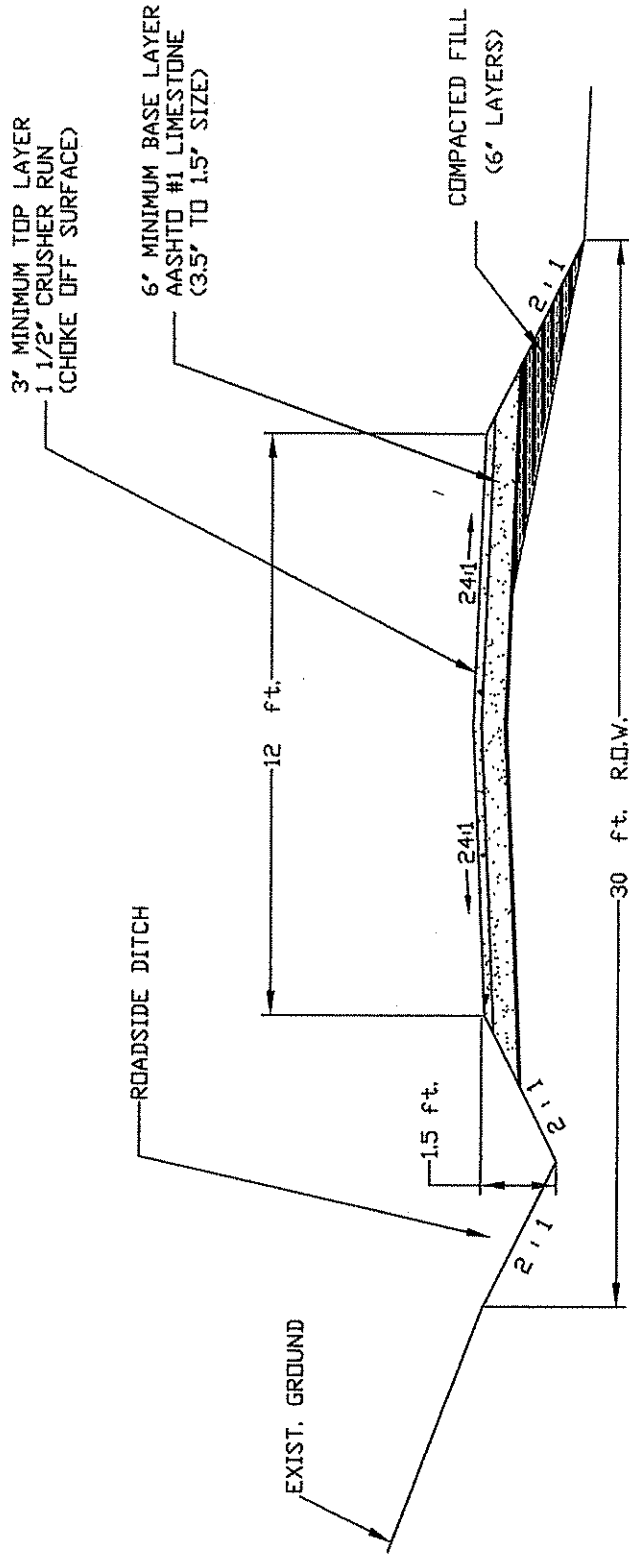

TYPICAL SECTION

- NOTES:
- THE EXISTING ROAD SHALL BE REGRADED, SHAPED, AND ROCKED AS NECESSARY TO MEET THESE SPECIFICATIONS.
 - ANY TREES OR BRUSH WITHIN THE 30 FEET R.O.W. OF THE ROAD SHALL BE REMOVED.
 - ANY OVERHANGING TREE LIMBS IN THE R.O.W. AT A HEIGHT OF 15 FEET OR LESS SHALL BE REMOVED.

NEW ACCESS ROAD

NEW ACCESS ROAD

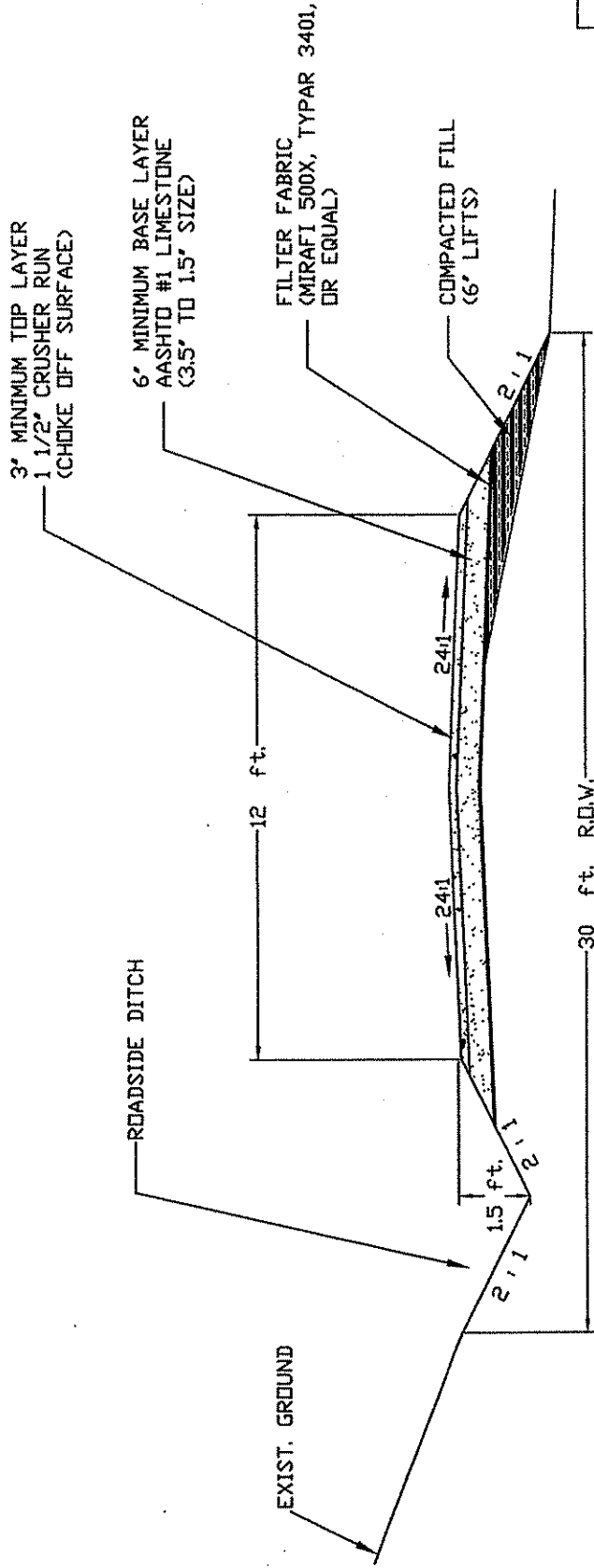

TYPICAL SECTION

NOTES: ANY TREES OR BRUSH WITHIN THE 30 FEET R.O.W. OF THE ROAD SHALL BE REMOVED.
 ANY OVERHANGING TREE LIMBS IN THE R.O.W. AT A HEIGHT OF 15 FEET OR LESS SHALL BE REMOVED.

CULVERT INSTALLATION

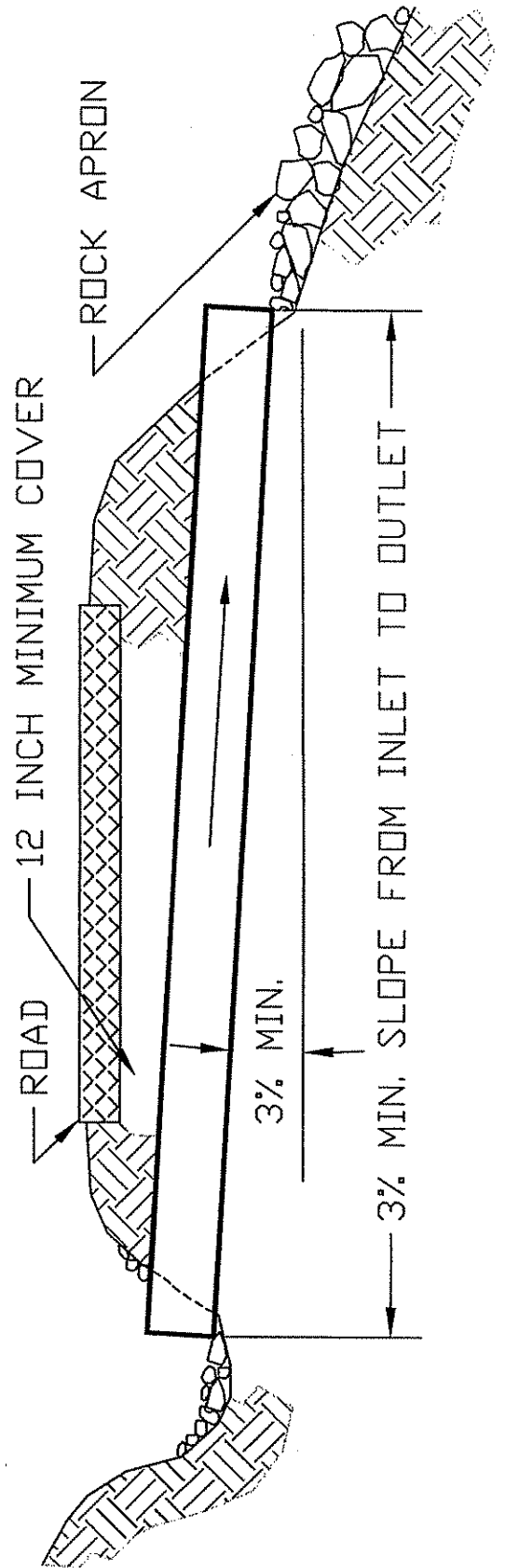
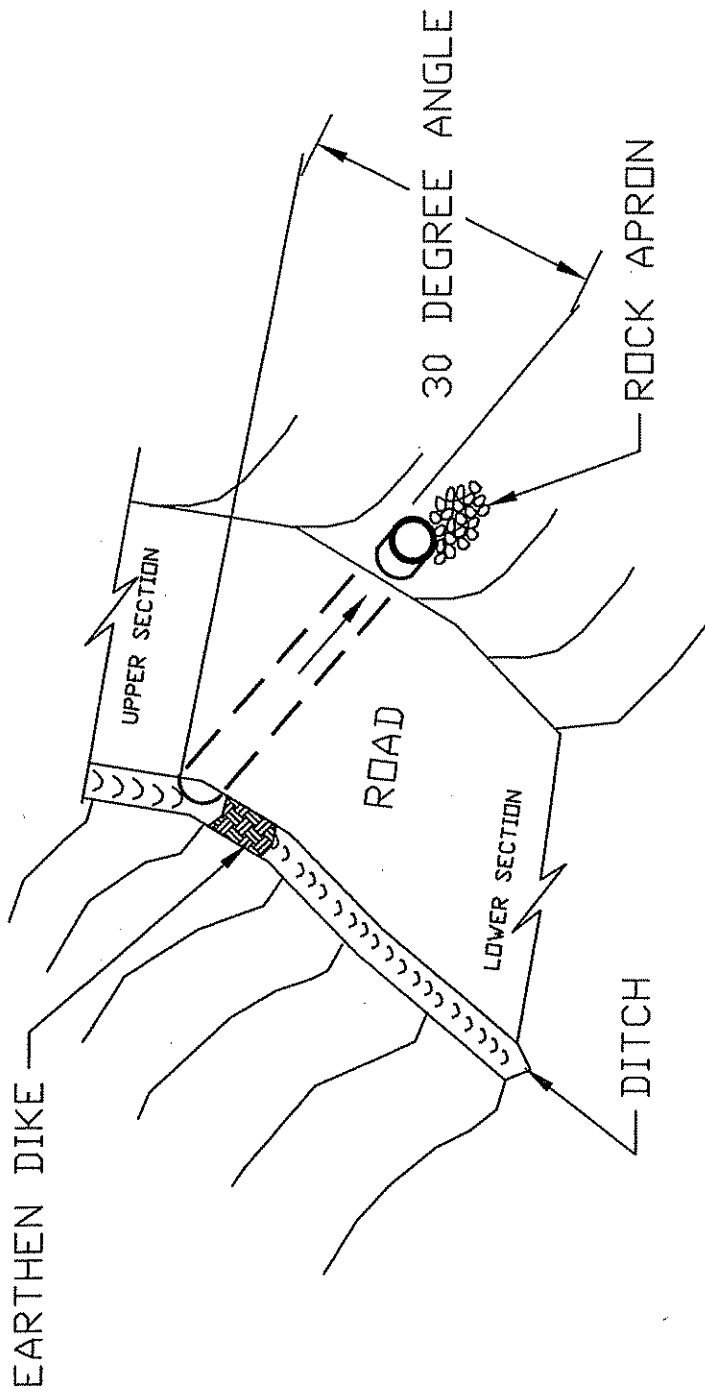

V - DITCH 4' WIDE

V - DITCH

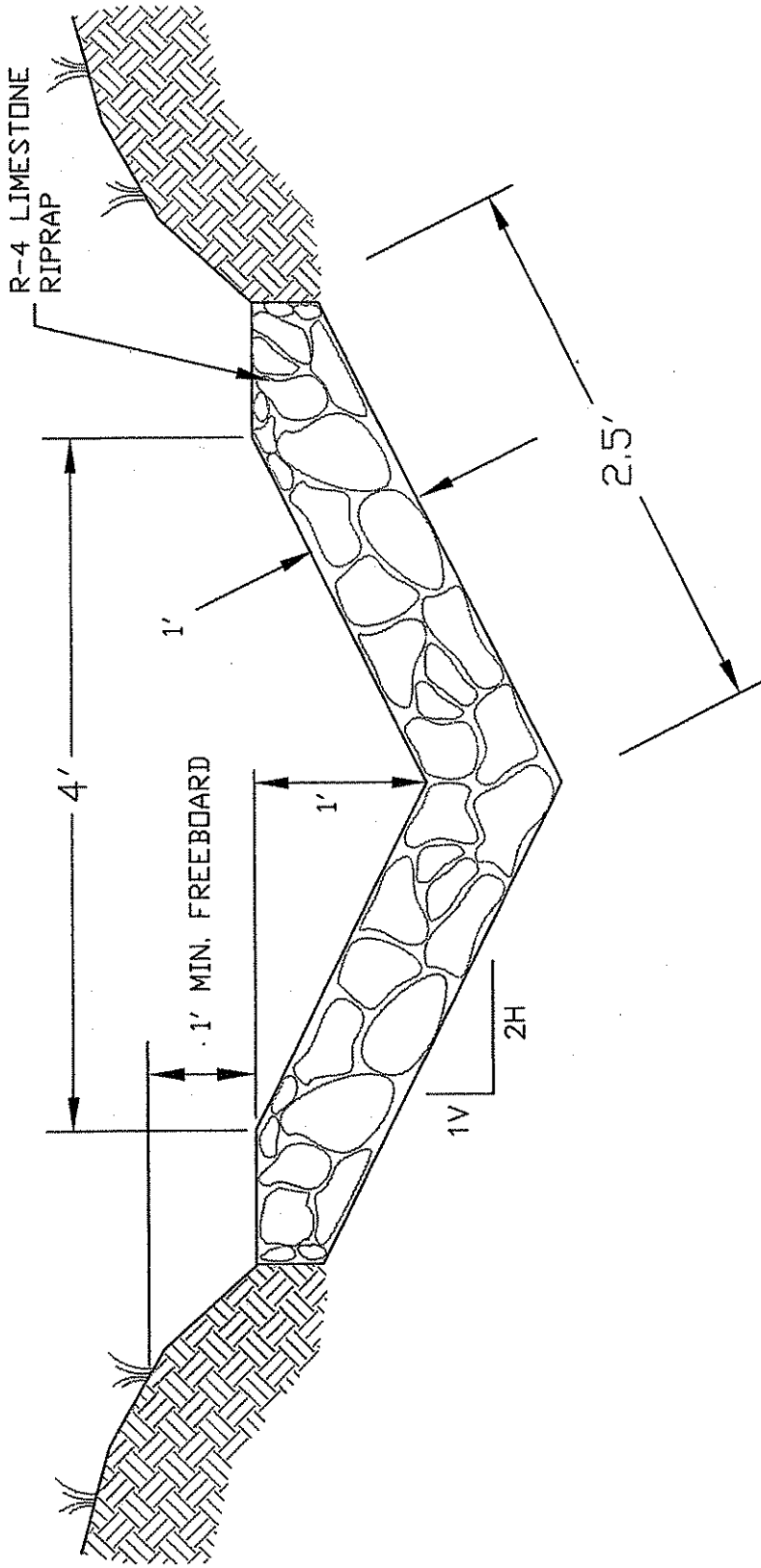

NOT TO SCALE

PAYMENT SHALL BE FOR ACTUAL LENGTH OF DITCH CONSTRUCTED.

R-4 LIMESTONE RIPRAP (STANDARD) UNLESS OTHERWISE NOTED, RIPRAP SHALL BE DURABLE ROCK PLACED IN A 1.0 FOOT BLANKET. TWENTY-FIVE (25%) OF THE ROCK WILL BE OF 12 INCHES OR LARGER, THE REMAINING SEVENTY-FIVE (75%) SHALL BE WELL GRADED MATERIAL (MINIMUM 3 INCHES TO MAXIMUM 9 INCHES) OF SUFFICIENT ROCK SMALL ENOUGH TO FILL THE VOIDS BETWEEN THE LARGER ROCK. SHALE SHALL NOT BE USED FOR RIPRAP. IF RIPRAP STABILITY IS QUESTIONABLE, DURABILITY SHALL BE DETERMINED BY THE SODIUM SULPHATE TEST ASTM C 88/AASHTO T 104-77.

SEDIMENT CONTROL SUMP

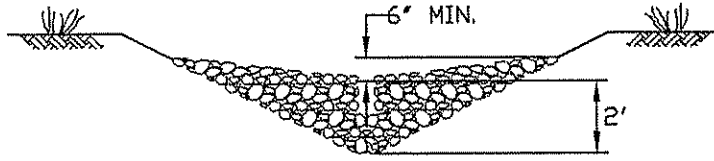

SECTION A-A

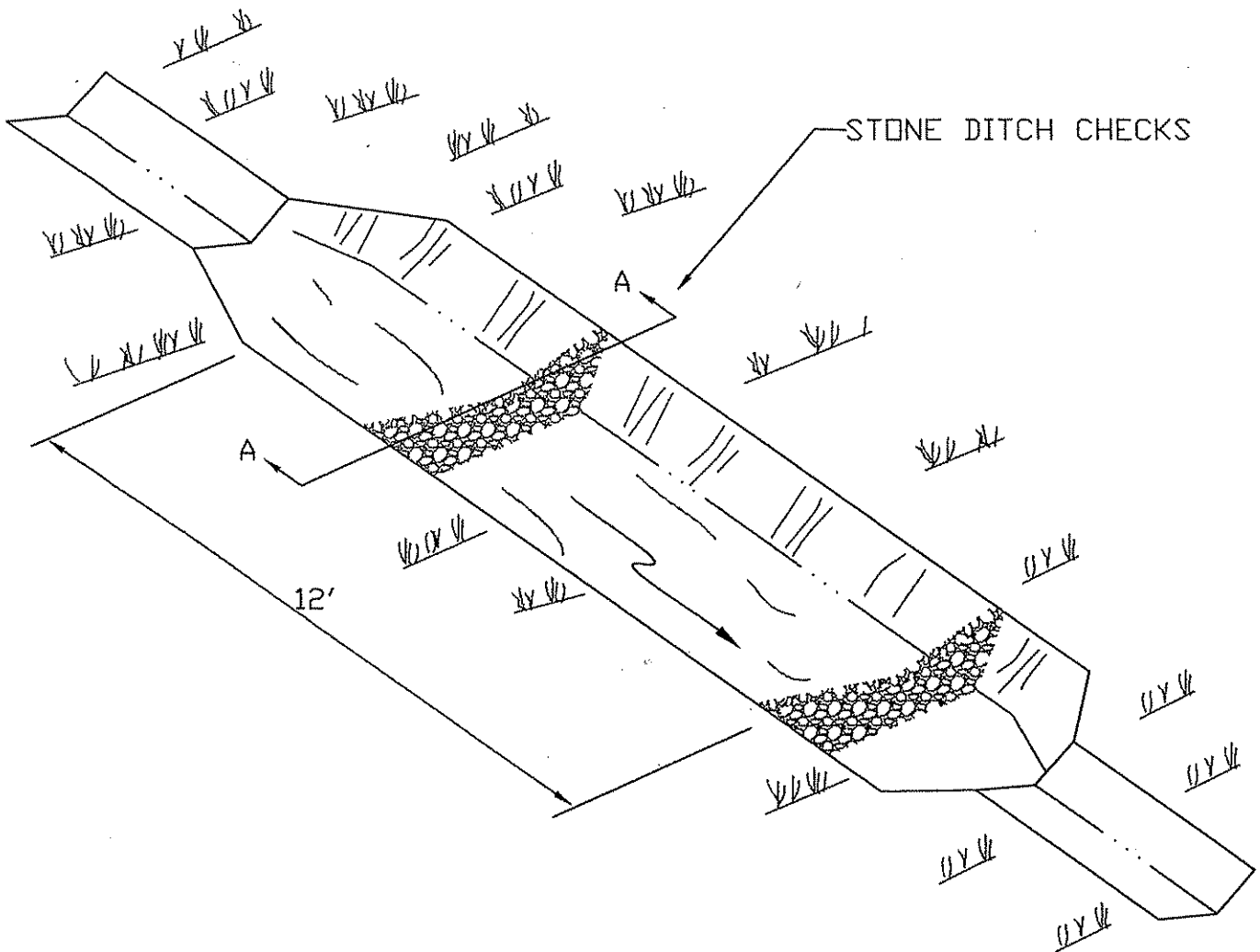

NOTE:
SEDIMENT CONTROL SUMPS SHALL BE A TOTAL DEPTH OF 4.0 FEET, INCLUDING 1.0 FEET OF FREEBOARD. THE WIDTH SHALL BE 6.0 FEET AND LENGTH SHALL BE 12.0 FEET.

AT COMPLETION OF THE PROJECT, THE SUMPS SIDE SLOPES SHALL HAVE RIPRAP INSTALLED TO PREVENT LONG TERM EROSION.

DOUBLE PIPE MINE DRAIN

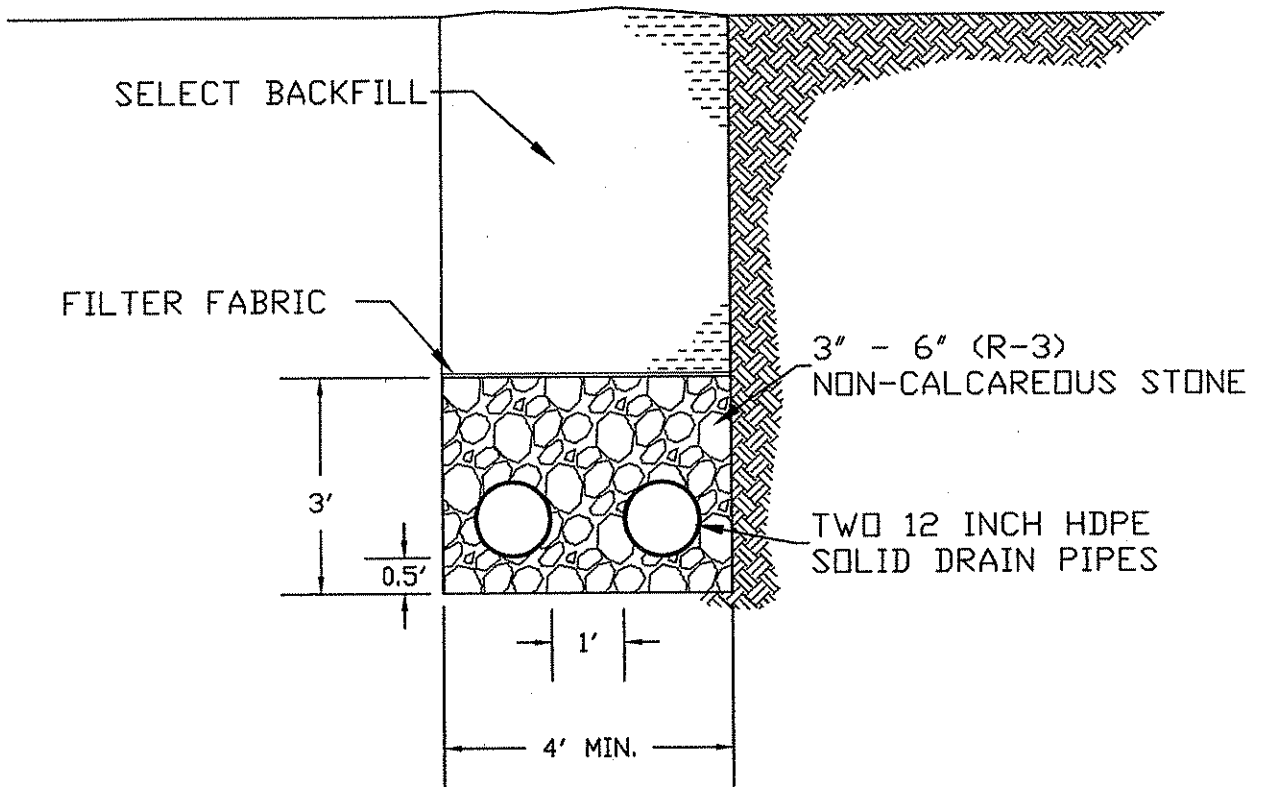

ANIMAL GUARD DETAIL

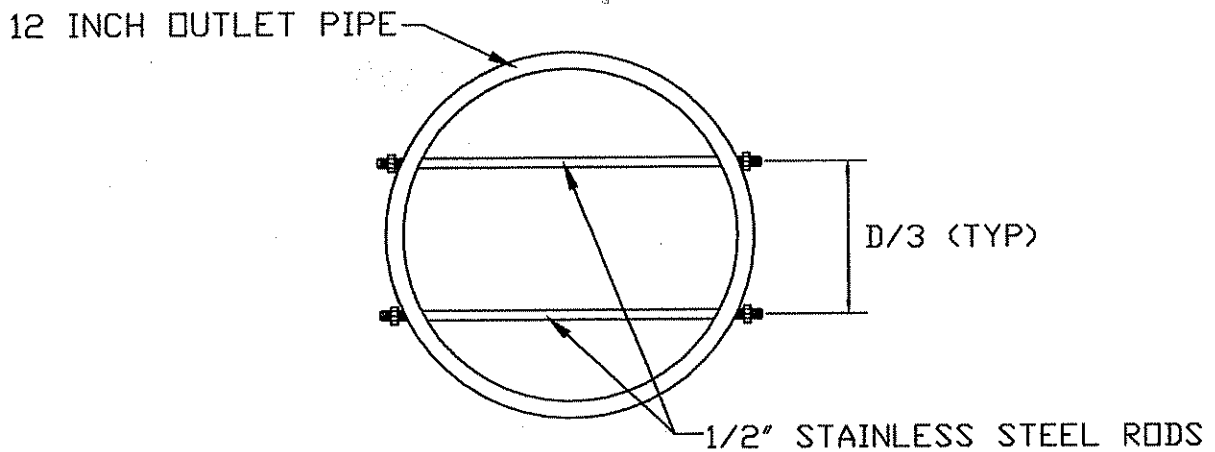

NOTE: ANIMAL GUARDS SHALL BE PLACED ON EACH PIPE DISCHARGE END AT THE SETTLING POND.

SETTLING POND

SETTLING POND

PLAN VIEW

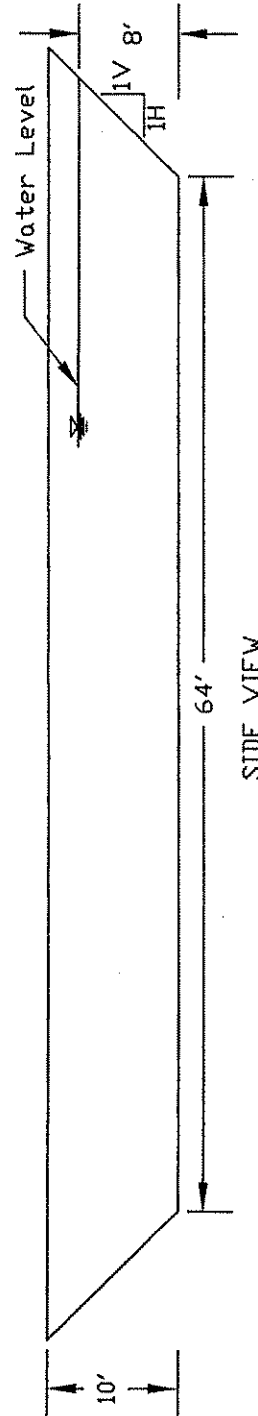
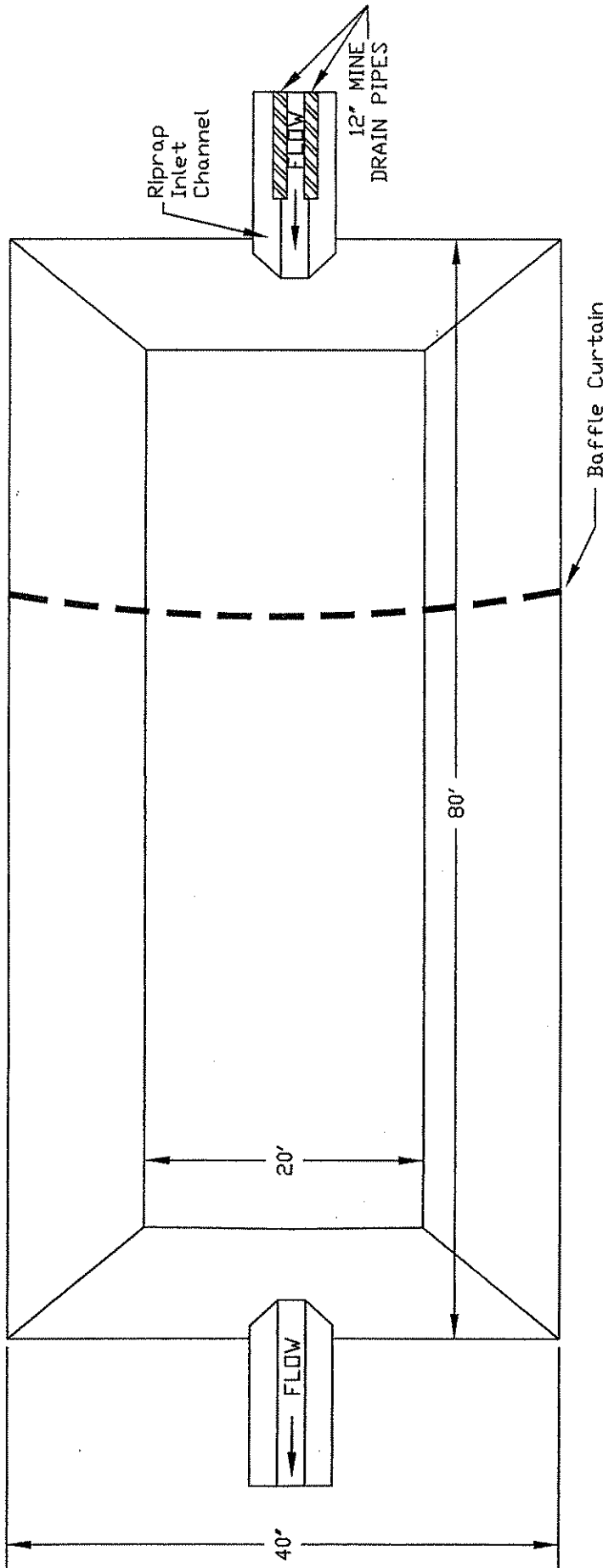

SIDE VIEW

Not To Scale

- NOTES: 1. A 12 FEET WIDE TOP POND BERM SHALL BE CONSTRUCTED AROUND THE ENTIRE POND.
 2. THE 12 INCH DIAMETER MINE DRAINS SHALL ENTER THE POND THROUGH A SECTION OF RIPRAP CHANNEL.

PROFILE AT BOREHOLE

BOREHOLE #4
139.0' TO BOTTOM
(SEE BORE LOG)

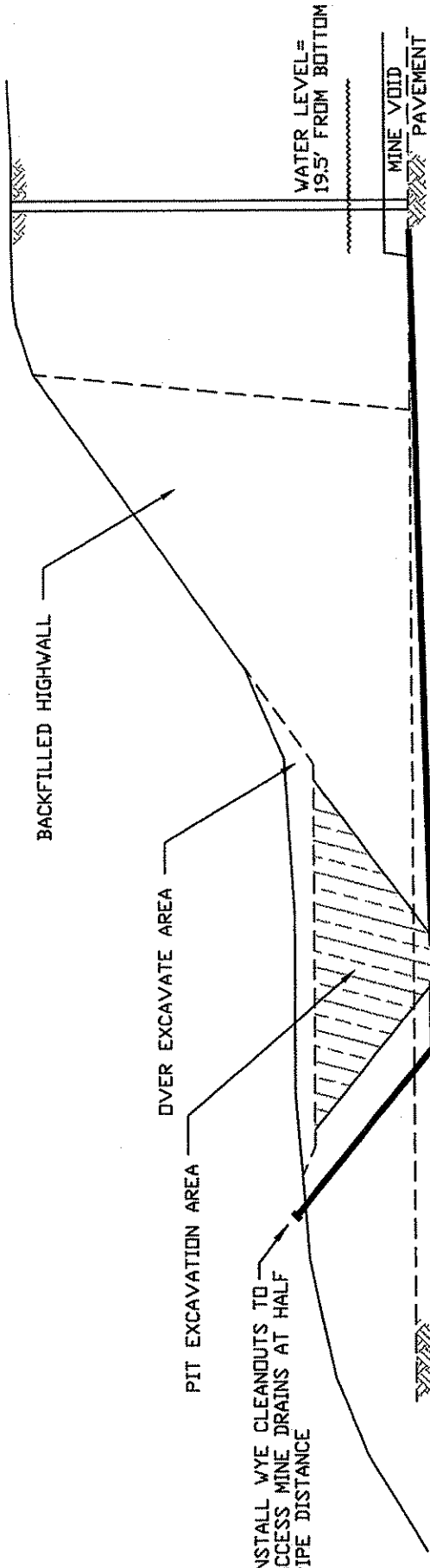

WATER LEVEL =
19.5' FROM BOTTOM

MINE VOID
PAVEMENT

BACKFILLED HIGHWALL

OVER EXCAVATE AREA

PIT EXCAVATION AREA

INSTALL WYE CLEANOUTS TO
ACCESS MINE DRAINS AT HALF
PIPE DISTANCE

MINE PIPE AND CASING SHALL BE
INSTALLED ON A 0.5% TO 1.0%
UPWARD SLOPE INTO THE BOTTOM
OF THE MINE VOID AREA

START HORIZONTAL BORE MINIMUM
2 FEET BELOW PAVEMENT

MINE PIPES SHALL BE INSTALLED
ON A 0.8% TO 1.0% DOWNWARD
SLOPE AND DISCHARGE INTO THE
SETTLING POND

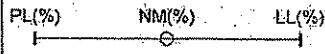
 Novel Geo-Environmental		Project Name: Frush Enterprises, Inc. Harrison County, WV				BORING NO.						
		Project Number: W07090				B-4						
Depth, feet	Sample Type	Symbol / USCS	Location: Surface El.: —		Recovery %	RQD	Penetration Blows / 6 inches	Silt and Clay %	PL(%) NM(%) LL(%) 			
			☒ Split Spoon ☒ Shelby Tube ■ Rock Core □ Bag Sample	● SPT bpf 10 20 30 40								
MATERIAL DESCRIPTION												
5			Brown SANDY CLAY, moist		5.0							
10			Brown and gray SHALE, very soft to medium hard		50	0						
15					68	22						
20					100	84						
25			- w/occasional sandstone laminations (21.0 - 32.0 ft.)		98	46						
30					100	62						
35			Brown and gray SANDSTONE, medium hard to hard		32.5	100	92					
40			- lost drilling water circulation @ 38.0 ft.		100	28						
45			Gray SHALE, medium hard		43.8	92	50					
50					100	66						
55					98	70						
60					100	48						

LOG OF BORING 1 W07090.S.P.J. AGELOG.GDT. 12/23/07

Completion Depth: **143.0 ft.**
 Date Boring Started: **11/27/07**
 Date Boring Completed: **11/28/07**
 Engineer/Geologist: **JEN**
 Driller: **NOVEL**

Remarks: **Piezometer set at a depth of 140.7 ft.**
 Depth to Water @ 24 hrs.: **—**

Novel Geo-Environmental

The stratification lines represent approximate strata boundaries. In situations, the transition may be gradual.

Novel Geo-Environmental Project Name: **Frush Enterprises, Inc. Harrison County, WV** BORING NO. **B-4**
 Project Number: **W07090**

Depth, feet	Sample Type	Symbol / USCS	Location:	Offset:	Recovery %	RQD	Penetration Blows / 5 inches	Silt and Clay %	PL(%) NM(%) LL(%)					
			Surface El.: --											
			<input type="checkbox"/> Split Spoon	<input checked="" type="checkbox"/> Shelby Tube										
			<input type="checkbox"/> Rock Core	<input type="checkbox"/> Bag Sample										
MATERIAL DESCRIPTION											10	20	30	40
65			Gray SHALE, soft to medium hard			96	40							
70						98	48							
75						100	94							
80						98	44							
85						96	38							
90						100	98							
95			- coal band (96.1 - 96.4 ft.)			98	72							
100						98	94							
105						94	66							
110						100	84							
115						100	100							
120						100	88							

Log of Boring: **WV07090.GP, NOEL001.GBT, 12/28/07**

Completion Depth: **143.0 ft.** Remarks: **Piezometer set at a depth of 140.7 ft.**

Date Boring Started: **11/27/07**





Date Boring Completed: **11/28/07**

Engineer/Geologist: **JEN**

Driller: **NOVEL** Depth to Water @ 24 hrs: **--**

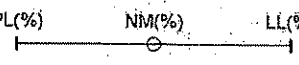
Novel Geo-Environmental

The stratification lines represent approximate strata boundaries. In situations, the transition may be gradual.

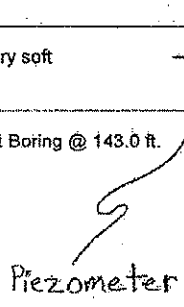
 Novel Geo-Environmental		Project Name: Frush Enterprises, Inc. Harrison County, WV Project Number: W07090			BORING NO. B-4							
Depth, feet	Sample Type	Symbol / USCS	Location: Offset		Recovery %	RQD	Penetration Blows / 6 inches	Silt and Clay %	PL(%) NM(%) LL(%) 			
			Surface El.: ---						<input type="checkbox"/> Split Spoon <input type="checkbox"/> Shelby Tube <input type="checkbox"/> Rock Core <input type="checkbox"/> Bag Sample		● SPT bpf 10 20 30 40	
MATERIAL DESCRIPTION												
125			Gray SHALE, soft to medium hard		100	82						
130			VOID		30	18						
135			MINE DEBRIS		40	30						
140			Gray CLAYSTONE, very soft		38	16						
143.0			Bottom of Test Boring @ 143.0 ft.		88	41						
145			Piezometer 									
150												
155												
160												
165												
170												
175												
180												

LOG OF BORING: 1. W07090 (P.1) NG&E LOG.GDT 12/23/07

Completion Depth: **143.0 ft.**
 Date Boring Started: **11/27/07**
 Date Boring Completed: **11/28/07**
 Engineer/Geologist: **JEN**
 Driller: **NOVEL**

Remarks: **Piezometer set at a depth of 140.7 ft.**
 Depth to Water @ 24 hrs.: ---

STATE OF WEST VIRGINIA
Purchasing Division

052

PURCHASING AFFIDAVIT

West Virginia Code §5A-3-10a states: No contract or renewal of any contract may be awarded by the state or any of its political subdivisions to any vendor or prospective vendor when the vendor or prospective vendor or a related party to the vendor or prospective vendor is a debtor and the debt owed is an amount greater than one thousand dollars in the aggregate

DEFINITIONS:

"Debt" means any assessment, premium, penalty, fine, tax or other amount of money owed to the state or any of its political subdivisions because of a judgment, fine, permit violation, license assessment, defaulted workers' compensation premium, penalty or other assessment presently delinquent or due and required to be paid to the state or any of its political subdivisions, including any interest or additional penalties accrued thereon.

"Debtor" means any individual, corporation, partnership, association, limited liability company or any other form or business association owing a debt to the state or any of its political subdivisions. "Political subdivision" means any county commission; municipality; county board of education; any instrumentality established by a county or municipality; any separate corporation or instrumentality established by one or more counties or municipalities, as permitted by law; or any public body charged by law with the performance of a government function or whose jurisdiction is coextensive with one or more counties or municipalities. "Related party" means a party, whether an individual, corporation, partnership, association, limited liability company or any other form or business association or other entity whatsoever, related to any vendor by blood, marriage, ownership or contract through which the party has a relationship of ownership or other interest with the vendor so that the party will actually or by effect receive or control a portion of the benefit, profit or other consideration from performance of a vendor contract with the party receiving an amount that meets or exceed five percent of the total contract amount.

EXCEPTION: The prohibition of this section does not apply where a vendor has contested any tax administered pursuant to chapter eleven of this code, workers' compensation premium, permit fee or environmental fee or assessment and the matter has not become final or where the vendor has entered into a payment plan or agreement and the vendor is not in default of any of the provisions of such plan or agreement.

LICENSING: Vendors must be licensed and in good standing in accordance with any and all state and local laws and requirements by any state or local agency of West Virginia, including, but not limited to, the West Virginia Secretary of State's Office, the West Virginia Tax Department, West Virginia Insurance Commission, or any other state agencies or political subdivision. Furthermore, the vendor must provide all necessary releases to obtain information to enable the Director or spending unit to verify that the vendor is licensed and in good standing with the above entities.

CONFIDENTIALITY: The vendor agrees that he or she will not disclose to anyone, directly or indirectly, any such personally identifiable information or other confidential information gained from the agency, unless the individual who is the subject of the information consents to the disclosure in writing or the disclosure is made pursuant to the agency's policies, procedures and rules. Vendors should visit www.state.wv.us/admin/purchase/privacy for the Notice of Agency Confidentiality Policies.

Under penalty of law for false swearing (West Virginia Code, §61-5-3), it is hereby certified that the vendor acknowledges the information in this said affidavit and are in compliance with the requirements as stated.

Vendor's Name: J.F. ALLEN COMPANY
Authorized Signature: Michael D. Myle Date: JULY 22, 2008



State of West Virginia
 Department of Administration
 Purchasing Division
 2019 Washington Street East
 Post Office Box 50130
 Charleston, WV 25305-0130

Request for Quotation

RFQ NUMBER
DEP14149

PAGE
1

ADDRESS CORRESPONDENCE TO ATTENTION OF
**CHUCK BOWMAN
 304-558-2157**

VENDOR

**J F Allen Co.
 Attention: James Allen
 PO Box 2049
 Buckhannon, WV 26201**

SHIP TO

**ENVIRONMENTAL PROTECTION
 DEPT. OF
 OFFICE OF SPECIAL RECLAMATION
 105 S. RAILROAD STREET
 PHILIPPI, WV
 26416-9998 304-457-3219**

DATE PRINTED	TERMS OF SALE	SHIP VIA	F.O.B.	FREIGHT TERMS
07/10/2008				

BID OPENING DATE: **07/23/2008** BID OPENING TIME **01:30PM**

LINE	QUANTITY	UOP	CAT. NO	ITEM NUMBER	UNIT PRICE	AMOUNT
***** ADDENDUM NO. 1 ***** ADDENDUM ISSUED FOR THE FRUSH ENTERPRISES PROJECT TO DISTRIBUTE THE PRE-BID SIGN-IN SHEET & THE Q/A RESULT- ING FROM THE 06/24/08 PRE-BID MEETING. BID OPENING DATE AND TIME REMAIN UNCHANGED AS 07/23/08 AT 1:30 PM. ***** NO OTHER CHANGES *****						
0001	1	JB		962-73		
RECLAMATION: RESTORATION OF WATER						

SEE REVERSE SIDE FOR TERMS AND CONDITIONS

SIGNATURE <i>gms</i>	TELEPHONE 304-472-8890	DATE JUL 22, 2008
TITLE VICE PRESIDENT	FERN 550328627	ADDRESS CHANGES TO BE NOTED ABOVE

WHEN RESPONDING TO RFQ, INSERT NAME AND ADDRESS IN SPACE ABOVE LABELED 'VENDOR'

MANDATORY PRE-BID SIGN-IN ATTENDANCE SHEET

002

RFQ # : DEP14149 Bid Date: 07/23/08
 Project: Frush Enterprises, Inc. Pre-Bid Date: 6/24/08
S-1008-89

Name : Robert Barnes
 Company: Barnes Exc. Inc.
 Address: P.O. Box 13384
Sissonville wva
25360
 Phone #: 304-984-1725
 Fax #: 304-984-0074
 Email : BARNES EXC@AOL.COM

Name : J.L. Pre Charlene Pretzel
 Company: J.L. Pretzel Contracting
 Address: 9 Belgian Estates
T. Brantton Mills WV
 Phone#: (304) 379-7789
 Fax #: SAME
 Email : pretzel@aol.com

Name : DANIEL MADONIA SERU
 Company: 226 N. D. KEN
 Address: GRAFTON
304 265 0188
Care Road
 Phone #: _____
 Fax #: 304 265 0258
 Email : _____

Name : DAVID H. BOWMAN
 Company: GREEN MOUNTAIN CO.
 Address: 511 50th STREET
CHARLESTON WV
25304
 Phone#: 304 925 0253
 Fax #: 925 9230
 Email : Jody Maje@AOL.COM

Name : GARY LONG
 Company: McCourt & Son Const.
 Address: 2790 Centralia Rd.
Sutton WV 26601
 Phone #: 304 765-5288
 Fax #: 304 765-5293
 Email : _____

Name : Travis Barber
 Company: Mid Atlantic Site Dev. Inc.
 Address: 332 Tub Run Hollow Rd.
Hedgesville, WV 25427
 Phone#: 304 229 4111
 Fax #: 304 229 0911
 Email : Travis Barber@MASDINC.COM

Name : NANCY SOMERS
 Company: MIDWAY RECLAMATION LLC
 Address: P.O. BOX 308
WEST MILFORD WV 26451
 Phone #: 304-745-3652
 Fax #: 304 745-3653
 Email : _____

Name : Jim Myers
 Company: MASD, INC.
 Address: 332 Tub Run Hollow Rd.
Hedgesville, WV 25427
 Phone#: 304 229 4111
 Fax #: 304- 229- 0911
 Email : bioblasts@yaho.com

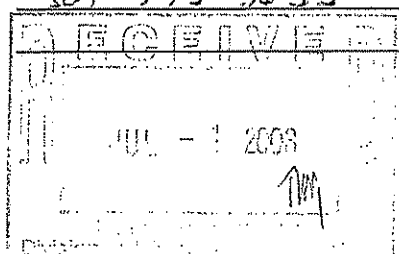

MANDATORY PRE-BID SIGN-IN ATTENDANCE SHEET 003

RFQ # : DEP14149 Bid Date: 07/23/08
 Project: Frush Enterprises, Inc. Pre-Bid Date: 6/24/08
S-1008-89

Name : Spencer C Wooddell
 Company: Cougirl Up Inc.
 Address: P.O. Box 243
Simpson, WV 26435
 Phone #: 304 739-4397
 Fax #: 304 739-4397
 Email : frw-cougirlup@earthlink.net

Name : JAMES ALLEN
 Company: JF ALLEN CO
 Address: P. O. Box 2049
Buckhannon WV 26201
 Phone#: 304 472 8890
 Fax #: 304 472 8897
 Email :

Name : BOB CALVERT JR
 Company: GREEN RIVER Group
 Address: 532 AARBrook Sq.
MORGANTOWN WV 26508
 Phone #: 304 594 3991
 Fax #: 304 594-3992
 Email : BOBCALVERTJR@YAHOO.COM

Name : Doug Vincent
 Company: Breakaway Inc.
 Address: 1075 Old Turnpike Rd
Sefton, WV 26601
 Phone#: 765-5317
 Fax #: 765-5389
 Email : breakaway_wv@verizon.net

Name : DENNIS C. ELBOW
 Company: GROUND BREAKERS Inc
 Address: P.O. Box 1227
CLARKSBURG, WV 26302
 Phone #: 304-622-2400
 Fax #: 304-622-2410
 Email : groundbr@mg.cri.com

Name : Randy Carpenter
 Company: Carpenter Reclamation
 Address: P.O. Box 13015
Sissonville, WV
25360
 Phone#: 304-984-1115
 Fax #: 304-984-2770
 Email :

Name : Lonnie Walton
 Company: BEAR CONTRACTING
 Address: P.O. Box 1196
BRIDGEPORT
WV
 Phone #: 304-842-3002
 Fax # :
 Email :

Name : GEORGE FRESHOUR
 Company: EAGLE EXCAVATION INC.
 Address: P.O. Box 218
KENNA WV
25248
 Phone#: 204 372-4378
 Fax #: 304 372-4378
 Email : None

MANDATORY PRE-BID SIGN-IN ATTENDANCE SHEET

004

RFQ # : DEP14149

Bid Date: 07/23/08

Project: Frush Enterprises, Inc.

Pre-Bid Date: 6/24/08

S-1008-89

Name : Vance McCracken

Name : _____

Company: EV McCracken Const

Company: _____

Address: 1100 Charles Ave

Address: _____

Dunbar WV 25064

Phone #: 304 444 1598

Phone# : _____

Fax # : 304-768-1183

Fax # : _____

Email : vancevcc@hotmail.com

Email : _____

Name : _____

Name : _____

Company: _____

Company: _____

Address: _____

Address: _____

Phone #: _____

Phone# : _____

Fax # : _____

Fax # : _____

Email : _____

Email : _____

Name : David McCoy

Name : _____

Company: _____

Company: _____

Address: 6/24/08

Address: _____

Phone #: _____

Phone# : _____

Fax # : _____

Fax # : _____

Email : _____

Email : _____

Name : _____

Name : _____

Company: _____

Company: _____

Address: _____

Address: _____

Phone #: _____

Phone# : _____

Fax # : _____

Fax # : _____

Email : _____

Email : _____

**Addendum #1 - Questions During Pre-Bid Meeting
For DEP 14149
Frush Enterprises Permit # S-1008-89**

005

- 1.) Q. How much total linear feet do you estimate to get to the mine void?
A. 360 feet distance.
- 2.) Q. On Bid Item 9.3, how is that item paid for?
A. This item is to pay for up to 360 linear feet from the pit to the mine void, the contractor shall install two (2) 12-inch HDPE mine drain pipes and steel casing for each.
- 3.) Q. You were talking about 6 inch diameter pilot holes, what size pipe are putting in there?
A. The holes are for initially dewatering the mine. Then the holes will be bored larger to accept the 16 inch diameter steel casing. Then the 12 inch HDPE mine drain pipe shall be placed inside the casing and grouted in place.
- 4.) Q. So, is there going to be 1440 feet of casing going into the ground?
A. No, there will be up to 720 feet of casing because there are two mine drains. (360 feet each).
- 5.) Q. Is there two different bore pits?
A. No, there is only one bore pit.
- 6.) Q. So, you are paying for the pilot holes in single runs per linear feet?
A. Yes, because you may hit a solid block of coal the first time. You will have enough footage for four (4) holes. Only two are required.
- 7.) Q. How much of that are you going to pay for (pilot holes), are you going to pay for the hole 1440 feet or just what we hit? If we hit it the first time is that all we do?
A. We will pay you for the holes that you drill, up to four holes. If you hit mine voids on the first two attempts, then we will stop and pay for two.
- 8.) Q. That piezometer pipe, are you going to plug that when we get done?
A. No, not with this contract.
- 9.) Q. On the Wyes, do we need to put a cap or anything on that?
A. Yes, the next bid item (Flanges) covers a flange and a blank to be installed on the ground surface as a cap or cleanout.
- 10.) Q. Will those Wyes come up at a 45 degree angle?
A. Yes, to be able to jet the pipeline out toward the deep mine voids.
- 11.) Q. Do the mine drain outlet pipes have to be straight or can they curve around with the existing grade?
A. No, they can curve with the existing contour of the land.

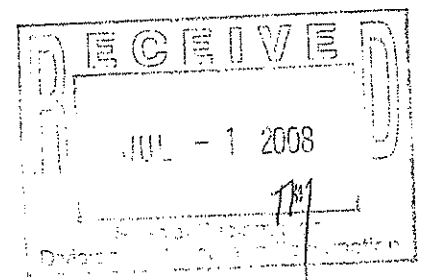

- 12.) Q. Bid item 10.0 Double 12-inch HDPE Pipe, will that be paid the same as the Double Mine Drains?
A. Yes, we will pay up to 500 linear feet for double pipe installation, so you may need as much as 1000 feet of pipe material.
- 13.) Q. Will we have to treat the water as the mine is being dewatered? Do you have water data?
A. Yes, you will have to treat it (Bid Item 18.0 Water Treatment). Yes, water data is available.
- 14.) Q. Was the coal augered?
A. A portion was strip mined, the center section was deep mined, possibly as early as 1930's or 1940's.
- 15.) Q. Is the bad water coming out on this side of the hill or the other side?
A. On this side, and has caused some slips.
- 16.) Q. Will he (landowner) have cattle in here while we are working?
A. No.
- 17.) Q. Is that a different landowner where we are parked?
A. Yes, but most of the work will be on Gordon Osbourne property.
- 18.) Q. Do you know where the outer part of the strip ends?
A. No, this is for the contractor to determine during construction.
- 19.) Q. How do we connect the HDPE mine drain pipe to the HDPE drain pipe to the sediment pond? Water may be flowing through the casing and/or the HDPE pipe, how do we connect it?
A. That is the contractor's choice, you can fusion weld it, or flange it and bolt together. If flanged, they shall be incidental to installing the pipe.
- 20.) Q. Do we have to install steel casing?
A. Yes, as a conduit for the HDPE pipe to enter the mine void.
- 21.) Q. Can the Wyes be flanged on, or do they have to be fused on?
A. Yes, but if so, stainless steel backer rings, bolts, and nuts must be used.
- 22.) Q. Do you have any idea of how long it will take to relief the water pressure from the 6 inch pilot holes?
A. No, the deep mine workings are not too extensive. 50 acres total surface area.
- 23.) Q. After the mine is drained, are we going to have to relocate the landowner's water source for the cattle or will he have to use the new settling pond?
A. If the existing water troughs are disturbed by the contractor, the contractor will be responsible for repairs or replacement of the troughs and/or pipes. The water feeding the existing troughs is above the deep mine coal seam and will not be effected by the mine dewatering.

- 24.) Q. Where can we put the stuff (material) out of the pond at?
A. Balance the cut and fill of the pond construction and use the cut material to build embankments on the lower end of the pond.
- 25.) Q. Is the pond site on original ground?
A. Another pond used to split the property lines, but was filled in, so there may be some fill at this pond site.
- 26.) Q. Does the discharge of the new pond extend onto the other property?
A. Yes, the exit channel will.
- 27.) Q. What dictates the proper elevations for the pond?
A. We have provided the borehole #4 depths, and have provided the percent slope requirements for pipes, and have a Construction Stakeout Bid Item (#6.0) to pay the contractor. The DEP shall verify the elevations of structures and pipe slopes prior to construction.
- 28.) Q. Do we have to have As-Built plans?
A. No, not required.
- 29.) Q. Are the inlet and exit channels to the settling pond trapezoidal in shape?
A. Yes, and will be paid under the V-Ditch Bid Item (#13.0). The trapezoidal ditch shall transition to a V shaped ditch after the pond berm.
- 30.) Q. Where is all of the V-Ditch to be installed?
A. Refer to the site map on page 38 of the requisition. The ditch shall extend from the settling pond down along the access road to the gate at the bottom of the road.
- 31.) Q. How far does this pipe extend back, does it go to the deep mine?
A. No, we do not believe the pipe extends far back into the hill side.
- 32.) Q. Do we have to perforate the pipe where seeps enter the trench?
A. No, the pipes are solid and sit 6 inches above the bottom of the trench with non-calcareous rock around the pipes as a seep collector.
- 33.) Q. Are you aware of any fuel in any old tanks that need removed as part of the Debris removal?
A. There are no tanks that we are aware of, but there are a few old 55 gallon drums. We do not know what was stored in them.

BID BOND

KNOW ALL MEN BY THESE PRESENTS, That we, the undersigned, J F Allen Company
of PO Box 2049 Buckhannon, WV 26201-2049, as Principal, and Western Surety
of PO Box 2872, Pittsburgh PA 15230, a corporation organized and existing under the laws of the State of South Dakota with its principal office in the City of Sioux Falls, as Surety, are held and firmly bound unto the State of West Virginia, as Obligee, in the penal sum of 5% amount bid (\$ 5% amount bid) for the payment of which, well and truly to be made, we jointly and severally bind ourselves, our heirs, administrators, executors, successors and assigns.

The Condition of the above obligation is such that whereas the Principal has submitted to the Purchasing Section of the Department of Administration a certain bid or proposal, attached hereto and made a part hereof, to enter into a contract in writing for DEP14149, Frush Enterprises, Inc. in Harrison County, according to plans and specifications.

NOW THEREFORE,

- (a) If said bid shall be rejected, or
- (b) If said bid shall be accepted and the Principal shall enter into a contract in accordance with the bid or proposal attached hereto and shall furnish any other bonds and insurance required by the bid or proposal, and shall in all other respects perform the agreement created by the acceptance of said bid, then this obligation shall be null and void, otherwise this obligation shall remain in full force and effect. It is expressly understood and agreed that the liability of the Surety for any and all claims hereunder shall, in no event, exceed the penal amount of this obligation as herein stated.

The Surety, for the value received, hereby stipulates and agrees that the obligations of said Surety and its bond shall be in no way impaired or affected by any extension of the time within which the Obligee may accept such bid, and said Surety does hereby waive notice of any such extension.

IN WITNESS WHEREOF, Principal and Surety have hereunto set their hands and seals, and such of them as are corporations have caused their corporate seals to be affixed hereunto and these presents to be signed by their proper officers, this 9th day of July, 2008.

Principal Corporate Seal

JF Allen Company
(Name of Principal)

By Michael D. Griffith
(Must be President or Vice President)

Michael Griffith, Vice President
(Title)

Surety Corporate Seal

Western Surety Company
(Name of Surety)

Ross E. Johnson
Attorney-in-Fact
Ross E. Johnson

IMPORTANT – Surety executing bonds must be licensed in West Virginia to transact surety insurance. Corporate seals must be affixed, and a power of attorney must be attached.

Western Surety Company

POWER OF ATTORNEY APPOINTING INDIVIDUAL ATTORNEY-IN-FACT

Know All Men By These Presents, That WESTERN SURETY COMPANY, a South Dakota corporation, is a duly organized and existing corporation having its principal office in the City of Sioux Falls, and State of South Dakota, and that it does by virtue of the signature and seal herein affixed hereby make, constitute and appoint

Ross E Johnson, Beverly A Holstine, Kathryn K Arthur, Sheila Mc Cormick, Individually

of Charleston, WV, its true and lawful Attorney(s)-in-Fact with full power and authority hereby conferred to sign, seal and execute for and on its behalf bonds, undertakings and other obligatory instruments of similar nature

- In Unlimited Amounts -

and to bind it thereby as fully and to the same extent as if such instruments were signed by a duly authorized officer of the corporation and all the acts of said Attorney, pursuant to the authority hereby given, are hereby ratified and confirmed.

This Power of Attorney is made and executed pursuant to and by authority of the By-Law printed on the reverse hereof, duly adopted, as indicated, by the shareholders of the corporation.

In Witness Whereof, WESTERN SURETY COMPANY has caused these presents to be signed by its Senior Vice President and its corporate seal to be hereto affixed on this 25th day of April, 2008.



WESTERN SURETY COMPANY

Paul T. Bruflat, Senior Vice President

State of South Dakota }
County of Minnehaha } ss

On this 25th day of April, 2008, before me personally came Paul T. Bruflat, to me known, who, being by me duly sworn, did depose and say: that he resides in the City of Sioux Falls, State of South Dakota; that he is the Senior Vice President of WESTERN SURETY COMPANY described in and which executed the above instrument; that he knows the seal of said corporation; that the seal affixed to the said instrument is such corporate seal; that it was so affixed pursuant to authority given by the Board of Directors of said corporation and that he signed his name thereto pursuant to like authority, and acknowledges same to be the act and deed of said corporation.

My commission expires

November 30, 2012

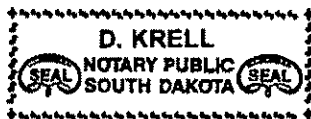

D. Krell, Notary Public

CERTIFICATE

I, L. Nelson, Assistant Secretary of WESTERN SURETY COMPANY do hereby certify that the Power of Attorney hereinabove set forth is still in force, and further certify that the By-Law of the corporation printed on the reverse hereof is still in force. In testimony whereof I have hereunto subscribed my name and affixed the seal of the said corporation this 9th day of July 2008.



WESTERN SURETY COMPANY

L. Nelson, Assistant Secretary

Authorizing By-Law

ADOPTED BY THE SHAREHOLDERS OF WESTERN SURETY COMPANY

This Power of Attorney is made and executed pursuant to and by authority of the following By-Law duly adopted by the shareholders of the Company.

Section 7. All bonds, policies, undertakings, Powers of Attorney, or other obligations of the corporation shall be executed in the corporate name of the Company by the President, Secretary, and Assistant Secretary, Treasurer, or any Vice President, or by such other officers as the Board of Directors may authorize. The President, any Vice President, Secretary, any Assistant Secretary, or the Treasurer may appoint Attorneys in Fact or agents who shall have authority to issue bonds, policies, or undertakings in the name of the Company. The corporate seal is not necessary for the validity of any bonds, policies, undertakings, Powers of Attorney or other obligations of the corporation. The signature of any such officer and the corporate seal may be printed by facsimile.

