



State of West Virginia
 Department of Administration
 Purchasing Division
 2019 Washington Street East
 Post Office Box 50130
 Charleston, WV 25305-0130

Request for Quotation

RFQ NUMBER:
COR61405

PAGE:
1

ADDRESS CORRESPONDENCE TO ATTENTION OF:
JOHN ABBOTT
304-558-2544

VENDOR

RFQ COPY
TYPE NAME/ADDRESS HERE

U.S. Cavalry Store, Inc.
2855 Centennial Ave.
Radcliff, KY 40160

SHIP TO

DIVISION OF CORRECTIONS
617 LEON SULLIVAN WAY
CHARLESTON, WV
25301 304-558-8045

DATE PRINTED	TERMS OF SALE	SHIP VIA	F.O.B.	FREIGHT TERMS
04/10/2009				

BID OPENING DATE: 04/28/2009 BID OPENING TIME 01:30PM

LINE	QUANTITY	UOP	CAT NO	ITEM NUMBER	UNIT PRICE	AMOUNT
0001	1	LS		680-12		
POLICE BELTS CASES, HOLSTERS, AND SCABBARDS (SHOP M						
See page 5 for total price						
OPEN-END CONTRACT TO PROVIDE BELTS, HOLSTERS, & ACCESSORIES FOR THE WV DIVISION OF CORRECTIONS' SECURITY STAFF, PER THE SPECIFICATIONS.						
EXHIBIT 3						
LIFE OF CONTRACT: THIS CONTRACT BECOMES EFFECTIVE ON AND EXTENDS FOR A PERIOD OF ONE (1) YEAR OR UNTIL SUCH "REASONABLE TIME" THEREAFTER AS IS NECESSARY TO OBTAIN A NEW CONTRACT OR RENEW THE ORIGINAL CONTRACT. THE "REASONABLE TIME" PERIOD SHALL NOT EXCEED TWELVE (12) MONTHS. DURING THIS "REASONABLE TIME" THE VENDOR MAY TERMINATE THIS CONTRACT FOR ANY REASON UPON GIVING THE DIRECTOR OF PURCHASING 30 DAYS WRITTEN NOTICE.						
UNLESS SPECIFIC PROVISIONS ARE STIPULATED ELSEWHERE IN THIS CONTRACT DOCUMENT, THE TERMS, CONDITIONS AND PRICING SET HEREIN ARE FIRM FOR THE LIFE OF THE CONTRACT.						
RENEWAL: THIS CONTRACT MAY BE RENEWED UPON THE MUTUAL WRITTEN CONSENT OF THE SPENDING UNIT AND VENDOR, SUBMITTED TO THE DIRECTOR OF PURCHASING THIRTY (30) DAYS PRIOR TO THE EXPIRATION DATE. SUCH RENEWAL SHALL BE IN ACCORDANCE WITH THE TERMS AND CONDITIONS OF THE ORIGINAL CONTRACT AND SHALL BE LIMITED TO TWO (2) ONE (1) YEAR PERIODS.						

RECEIVED

2009 APR 28 A 7:46

PURCHASING DIVISION
STATE OF WV

SEE REVERSE SIDE FOR TERMS AND CONDITIONS			
SIGNATURE <i>Danial E. Alinski</i>	TELEPHONE 800-200-9455	DATE 4-27-09	
TITLE Contract Sales	FEIN 61-0844897	ADDRESS CHANGES TO BE NOTED ABOVE	

WHEN RESPONDING TO RFQ, INSERT NAME AND ADDRESS IN SPACE ABOVE LABELED 'VENDOR'

GENERAL TERMS & CONDITIONS
REQUEST FOR QUOTATION (RFQ) AND REQUEST FOR PROPOSAL (RFP)

1. Awards will be made in the best interest of the State of West Virginia.
2. The State may accept or reject in part, or in whole, any bid.
3. All quotations are governed by the *West Virginia Code* and the *Legislative Rules* of the Purchasing Division.
4. Prior to any award, the apparent successful vendor must be properly registered with the Purchasing Division and have paid the required \$125 fee.
5. All services performed or goods delivered under State Purchase Order/Contracts are to be continued for the term of the Purchase Order/Contracts, contingent upon funds being appropriated by the Legislature or otherwise being made available. In the event funds are not appropriated or otherwise available for these services or goods, this Purchase Order/Contract becomes void and of no effect after June 30.
6. Payment may only be made after the delivery and acceptance of goods or services.
7. Interest may be paid for late payment in accordance with the *West Virginia Code*.
8. Vendor preference will be granted upon written request in accordance with the *West Virginia Code*.
9. The State of West Virginia is exempt from federal and state taxes and will not pay or reimburse such taxes.
10. The Director of Purchasing may cancel any Purchase Order/Contract upon 30 days written notice to the seller.
11. The laws of the State of West Virginia and the *Legislative Rules* of the Purchasing Division shall govern all rights and duties under the Contract, including without limitation the validity of this Purchase Order/Contract.
12. Any reference to automatic renewal is hereby deleted. The Contract may be renewed only upon mutual written agreement of the parties.
13. **BANKRUPTCY:** In the event the vendor/contractor files for bankruptcy protection, this Contract may be deemed null and void, and terminated without further order.
14. **HIPAA BUSINESS ASSOCIATE ADDENDUM:** The West Virginia State Government HIPAA Business Associate Addendum (BAA), approved by the Attorney General, and available online at the Purchasing Division's web site (<http://www.state.wv.us/admin/purchase/vrc/hipaa.htm>) is hereby made part of the agreement. Provided that, the Agency meets the definition of a Cover Entity (45 CFR §160.103) and will be disclosing Protected Health Information (45 CFR §160.103) to the vendor.
15. **WEST VIRGINIA ALCOHOL & DRUG-FREE WORKPLACE ACT:** If this Contract constitutes a public improvement construction contract as set forth in Article 1D, Chapter 21 of the West Virginia Code ("The West Virginia Alcohol and Drug-Free Workplace Act"), then the following language shall hereby become part of this Contract: "The contractor and its subcontractors shall implement and maintain a written drug-free workplace policy in compliance with the West Virginia Alcohol and Drug-Free Workplace Act, as set forth in Article 1D, Chapter 21 of the West Virginia Code. The contractor and its subcontractors shall provide a sworn statement in writing, under the penalties of perjury, that they maintain a valid drug-free work place policy in compliance with the West Virginia and Drug-Free Workplace Act. It is understood and agreed that this Contract shall be cancelled by the awarding authority if the Contractor: 1) Fails to implement its drug-free workplace policy; 2) Fails to provide information regarding implementation of the contractor's drug-free workplace policy at the request of the public authority; or 3) Provides to the public authority false information regarding the contractor's drug-free workplace policy."

INSTRUCTIONS TO BIDDERS

1. Use the quotation forms provided by the Purchasing Division.
2. **SPECIFICATIONS:** Items offered must be in compliance with the specifications. Any deviation from the specifications must be clearly indicated by the bidder. Alternates offered by the bidder as **EQUAL** to the specifications must be clearly defined. A bidder offering an alternate should attach complete specifications and literature to the bid. The Purchasing Division may waive minor deviations to specifications.
3. Complete all sections of the quotation form.
4. Unit prices shall prevail in case of discrepancy.
5. All quotations are considered F.O.B. destination unless alternate shipping terms are clearly identified in the quotation.
6. **BID SUBMISSION:** All quotations must be delivered by the bidder to the office listed below prior to the date and time of the bid opening. Failure of the bidder to deliver the quotations on time will result in bid disqualifications: Department of Administration, Purchasing Division, 2019 Washington Street East, P.O. Box 50130, Charleston, WV 25305-0130

U.S. Cavalry Store, Inc.
2855 Centennial Ave.
Radcliff, KY 40160

Rev. 7/01/08



State of West Virginia
 Department of Administration
 Purchasing Division
 2019 Washington Street East
 Post Office Box 50130
 Charleston, WV 25305-0130

Request for Quotation

RFQ NUMBER
COR61405

PAGE
2

ADDRESS CORRESPONDENCE TO ATTENTION OF
JOHN ABBOTT 304-558-2544

VENDOR

RFQ COPY
 TYPE NAME/ADDRESS HERE

U.S. Cavalry Store, Inc.
 2855 Centennial Ave.
 Radcliff, KY 40160

RFQ

DIVISION OF CORRECTIONS
 617 LEON SULLIVAN WAY
 CHARLESTON, WV
 25301 304-558-8045

DATE PRINTED	TERMS OF SALE	SHIP VIA	F.O.B.	FREIGHT TERMS
04/10/2009				

BID OPENING DATE: 04/28/2009 BID OPENING TIME 01:30PM

LINE	QUANTITY	UOP	CAT NO	ITEM NUMBER	UNIT PRICE	AMOUNT
<p>CANCELLATION: THE DIRECTOR OF PURCHASING RESERVES THE RIGHT TO CANCEL THIS CONTRACT IMMEDIATELY UPON WRITTEN NOTICE TO THE VENDOR IF THE COMMODITIES AND/OR SERVICES SUPPLIED ARE OF AN INFERIOR QUALITY OR DO NOT CONFORM TO THE SPECIFICATIONS OF THE BID AND CONTRACT HEREIN.</p> <p>OPEN MARKET CLAUSE: THE DIRECTOR OF PURCHASING MAY AUTHORIZE A SPENDING UNIT TO PURCHASE ON THE OPEN MARKET, WITHOUT THE FILING OF A REQUISITION OR COST ESTIMATE, ITEMS SPECIFIED ON THIS CONTRACT FOR IMMEDIATE DELIVERY IN EMERGENCIES DUE TO UNFORESEEN CAUSES (INCLUDING BUT NOT LIMITED TO DELAYS IN TRANSPORTATION OR AN UNANTICIPATED INCREASE IN THE VOLUME OF WORK.)</p> <p>QUANTITIES: QUANTITIES LISTED IN THE REQUISITION ARE APPROXIMATIONS ONLY, BASED ON ESTIMATES SUPPLIED BY THE STATE SPENDING UNIT. IT IS UNDERSTOOD AND AGREED THAT THE CONTRACT SHALL COVER THE QUANTITIES ACTUALLY ORDERED FOR DELIVERY DURING THE TERM OF THE CONTRACT, WHETHER MORE OR LESS THAN THE QUANTITIES SHOWN.</p> <p>ORDERING PROCEDURE: SPENDING UNIT(S) SHALL ISSUE A WRITTEN STATE CONTRACT ORDER (FORM NUMBER WV-39) TO THE VENDOR FOR COMMODITIES COVERED BY THIS CONTRACT. THE ORIGINAL COPY OF THE WV-39 SHALL BE MAILED TO THE VENDOR AS AUTHORIZATION FOR SHIPMENT, A SECOND COPY MAILED TO THE PURCHASING DIVISION, AND A THIRD COPY RETAINED BY THE SPENDING UNIT.</p> <p>BANKRUPTCY: IN THE EVENT THE VENDOR/CONTRACTOR FILES FOR BANKRUPTCY PROTECTION, THIS CONTRACT IS AUTOMATICALLY NULL AND VOID, AND IS TERMINATED WITHOUT FURTHER ORDER.</p>						

SEE REVERSE SIDE FOR TERMS AND CONDITIONS

SIGNATURE <i>David Z. Alinski</i>	TELEPHONE 800-200-9455	DATE 4-27-09
TITLE Contract Sales	FEIN 61-0844897	ADDRESS CHANGES TO BE NOTED ABOVE

WHEN RESPONDING TO RFQ, INSERT NAME AND ADDRESS IN SPACE ABOVE LABELED 'VENDOR'



State of West Virginia
 Department of Administration
 Purchasing Division
 2019 Washington Street East
 Post Office Box 50130
 Charleston, WV 25305-0130

Request for Quotation

RFQ NUMBER
 COR61405

PAGE
 3

ADDRESS CORRESPONDENCE TO ATTENTION OF
 JOHN ABBOTT
 304-558-2544

VENDOR

RFQ COPY
 TYPE NAME/ADDRESS HERE

U.S. Cavalry Store, Inc.
 2855 Centennial Ave.
 Radcliff, KY 40160

SHIP TO

DIVISION OF CORRECTIONS
 617 LEON SULLIVAN WAY
 CHARLESTON, WV
 25301 304-558-8045

DATE PRINTED	TERMS OF SALE	SHIP VIA	F.O.B.	FREIGHT TERMS
04/10/2009				

BID OPENING DATE: 04/28/2009 BID OPENING TIME 01:30PM

LINE	QUANTITY	UOP	CAT. NO.	ITEM NUMBER	UNIT PRICE	AMOUNT
<p>THE TERMS AND CONDITIONS CONTAINED IN THIS CONTRACT SHALL SUPERSEDE ANY AND ALL SUBSEQUENT TERMS AND CONDITIONS WHICH MAY APPEAR ON ANY ATTACHED PRINTED DOCUMENTS SUCH AS PRICE LISTS, ORDER FORMS, SALES AGREEMENTS OR MAINTENANCE AGREEMENTS, INCLUDING ANY ELECTRONIC MEDIUM SUCH AS CD-ROM.</p> <p>REV. 04/11/2001</p> <p>EXHIBIT 4</p> <p>LOCAL GOVERNMENT BODIES: UNLESS THE VENDOR INDICATES IN THE BID HIS REFUSAL TO EXTEND THE PRICES, TERMS, AND CONDITIONS OF THE BID TO COUNTY, SCHOOL, MUNICIPAL AND OTHER LOCAL GOVERNMENT BODIES, THE BID SHALL EXTEND TO POLITICAL SUBDIVISIONS OF THE STATE OF WEST VIRGINIA. IF THE VENDOR DOES NOT WISH TO EXTEND THE PRICES, TERMS, AND CONDITIONS OF THE BID TO ALL POLITICAL SUBDIVISIONS OF THE STATE, THE VENDOR MUST CLEARLY INDICATE SUCH REFUSAL IN HIS BID. SUCH REFUSAL SHALL NOT PREJUDICE THE AWARD OF THIS CONTRACT IN ANY MANNER.</p> <p>REV. 3/88</p> <p>PURCHASING CARD ACCEPTANCE: THE STATE OF WEST VIRGINIA CURRENTLY UTILIZES A VISA PURCHASING CARD PROGRAM WHICH IS ISSUED THROUGH A BANK. THE SUCCESSFUL VENDOR MUST ACCEPT THE STATE OF WEST VIRGINIA VISA PURCHASING CARD FOR PAYMENT OF ALL ORDERS PLACED BY ANY STATE AGENCY AS A CONDITION OF AWARD.</p> <p style="text-align: center;">NOTICE</p> <p>A SIGNED BID MUST BE SUBMITTED TO:</p>						

SEE REVERSE SIDE FOR TERMS AND CONDITIONS

SIGNATURE <i>David A. Alinski</i>	TELEPHONE 800-200-9455	DATE 4-27-09
TITLE Contract Sales	FEIN 61-0844897	ADDRESS CHANGES TO BE NOTED ABOVE

WHEN RESPONDING TO RFQ, INSERT NAME AND ADDRESS IN SPACE ABOVE LABELED 'VENDOR'



State of West Virginia
 Department of Administration
 Purchasing Division
 2019 Washington Street East
 Post Office Box 50130
 Charleston, WV 25305-0130

Request for Quotation

RFQ NUMBER
 COR61405

PAGE
 4

ADDRESS CORRESPONDENCE TO ATTENTION OF
 JOHN ABBOTT
 304-558-2544

VENDOR

RFQ COPY
 TYPE NAME/ADDRESS HERE

U.S. Cavalry Store, Inc.
 2855 Centennial Ave.
 Radcliff, KY 40160

SHIP TO

DIVISION OF CORRECTIONS
 617 LEON SULLIVAN WAY
 CHARLESTON, WV
 25301 304-558-8045

DATE PRINTED	TERMS OF SALE	SHIP VIA	F.O.B.	FREIGHT TERMS
04/10/2009				

BID OPENING DATE:

04/28/2009

BID OPENING TIME

01:30PM

LINE	QUANTITY	UOP	CAT NO	ITEM NUMBER	UNIT PRICE	AMOUNT
DEPARTMENT OF ADMINISTRATION PURCHASING DIVISION BUILDING 15 2019 WASHINGTON STREET, EAST CHARLESTON, WV 25305-0130						
THE BID SHOULD CONTAIN THIS INFORMATION ON THE FACE OF THE ENVELOPE OR THE BID MAY NOT BE CONSIDERED: SEALED BID						
BUYER:				JOHN ABBOTT-----		
RFQ. NO.:				COR61405-----		
BID OPENING DATE:				4/28/2009-----		
BID OPENING TIME:				1:30 PM-----		
PLEASE PROVIDE A FAX NUMBER IN CASE IT IS NECESSARY TO CONTACT YOU REGARDING YOUR BID: U.S. Cavalry FAX # (270)352-0327-----						
CONTACT PERSON (PLEASE PRINT CLEARLY): David R. Valinski-----						

SEE REVERSE SIDE FOR TERMS AND CONDITIONS

SIGNATURE <i>David R. Valinski</i>	TELEPHONE 800-200-9455	DATE 4-27-09
TITLE Contract Sales	FEIN 61-0844897	ADDRESS CHANGES TO BE NOTED ABOVE

WHEN RESPONDING TO RFQ, INSERT NAME AND ADDRESS IN SPACE ABOVE LABELED 'VENDOR'



State of West Virginia
 Department of Administration
 Purchasing Division
 2019 Washington Street East
 Post Office Box 50130
 Charleston, WV 25305-0130

Request for Quotation

RFQ NUMBER
 COR61405

PAGE
 5

ADDRESS CORRESPONDENCE TO ATTENTION OF
 JOHN ABBOTT
 304-558-2544

POSTAGE

RFQ COPY
 TYPE NAME/ADDRESS HERE

U.S. Cavalry Store, Inc.
 2855 Centennial Ave.
 Radcliff, KY 40160

SHIP TO

DIVISION OF CORRECTIONS
 617 LEON SULLIVAN WAY
 CHARLESTON, WV
 25301 304-558-8045

DATE PRINTED	TERMS OF SALE	SHIP VIA	FOB	FREIGHT TERMS
04/10/2009	Net 30 days	UPS or Freight Destination		Included

BID OPENING DATE: 04/28/2009 BID OPENING TIME 01:30PM

LINE	QUANTITY	UOP	CAT NO.	ITEM NUMBER	UNIT PRICE	AMOUNT
***** THIS IS THE END OF RFQ COR61405 ***** TOTAL:						\$62,743.05

SEE REVERSE SIDE FOR TERMS AND CONDITIONS

SIGNATURE <i>David A. Smith</i>	TELEPHONE 800-200-9455	DATE 4-27-09
TITLE Contract Sales	FEIN 61-0844897	ADDRESS CHANGES TO BE NOTED ABOVE

WHEN RESPONDING TO RFQ, INSERT NAME AND ADDRESS IN SPACE ABOVE LABELED 'VENDOR'

WVDOC Specifications for Duty Belt Gear

Item Number	Description	Projected Quantity
1	Nylon Duty Belt: Safariland Model 4307 or equal Ballistic Nylon 2.25 inch Laminated Duty Belt w/3X™ Locking Buckle And 2 Flex-Cuff channels. Sizes available: Must be available in a range of sizes to cover from a 20 inch to 62 inch waist Color: Black	250 Gould&Goodrich Model X50
2	Buckleless Police Pants Belt for wear under duty belt: Safariland Model 4325 or equal Nylok®Pro/Leather Laminated Reversible Police Pants, Full Length, Loop Lining, 1.50 inch. Color: Black	193 Gould&Goodrich Model X55
3	Nylon Double Magazine Pouch: Safariland Model 4110, or equal Nylok®Pro laminated molded construction Double Magazine Holder with two-way 2.25 inch belt loop for either vertical or horizontal use, adjustable tension screw. Must fit magazines for Glock Model 21SF .45 ACP pistol. Color: black with black snaps.	366 Gould&Goodrich Model X647
4	Nylon Single Magazine Pouch: Safariland Model 4100, or equal Nylok®Pro laminated molded construction Single Magazine Holder with two-way 2.25 inch belt loop for either vertical or horizontal use, adjustable tension screw. Must fit magazines for Glock Model 21SF .45 ACP pistol. Color: black with black snaps.	0 Gould&Goodrich Model X628
5	Nylon Handcuff Pouch Single: Safariland Model 4258 or equal Nylok®Pro laminated molded construction handcuff pouch, single, flap top, for use with 2.25 inch duty belt to fit most chained handcuffs Color: Black with black snap	218 Gould&Goodrich Model X70
6	Nylon Handcuff Pouch Double: Safariland Model 4260 or equal Nylok®Pro laminated molded construction handcuff pouch, double, flap top, for use with 2.25 inch duty belt to hold two pairs of most chained handcuffs or one set of leg irons. Color: Black with black snap	0 Gould&Goodrich Model X596
7	Nylon OC Spray Pouch: Safariland Model 4278 or equal Nylok®Pro laminated molded construction OC spray pouch, flap top, for use with 2.25 inch duty belt to fits most canisters up to 4.5 inches (11cm) high Color: Black with black snap	205 Gould& Goodrich Model X681-3
8	Nylon Baton Pouch: Safariland Model 4208 or equal Nylok®Pro laminated molded construction, to fit most 21" or 26" foam handled expandable batons for use with 2.25 inch duty belt Color: black	221 Gould&Goodrich Model X560-21 X560-26

U.S. Cavalry Store, Inc.
2855 Centennial Ave.
Radcliff, KY 40160

- 9 Nylon Deluxe Glove/Microshield Case: Safariland Model 4620 or equal Deluxe Glove/Microshield Case with two compartments to carry two pairs of latex gloves or one pair of gloves and one microshield, size 3" x 3" x 1.5" (8cm x 8 cm x 4cm) for use with 2.25 inch duty belt
color: black with black snap 224
Gould&Goodrich
Model X555
- 10 Double Magazine Holder, Concealment: Safariland Model 079 or equal double magazine Holder, low cut, flap-less design for easy magazine grasp, adjustable tension device, for use with belts up to 1.75 inches. **Must fit magazines for Glock Model 21SF .45 ACP pistol.**
Color: Plain Black 26
Gould&Goodrich
Model B851
- 11 Handcuff Case, Concealment: Safariland Model 590 or equal thermal formed laminate handcuff holder to hold handcuff firmly and quietly in place, paddle design with self-locking belt loop to fit up to a 1.75 inch belt
color: Plain Black 42
Gould&Goodrich
Model BB820
- 12 Plainclothes belt, leather 1.50 inches: Safariland Model L830 or equal 1.50 inch leather plainclothes belt designed to support the weight of large handguns and their holsters, suede lined, color border stitched, chrome buckle (user removable). Must be available in a range of sizes to cover from a 24 inch to 44 inch waist (indicate if larger sizes are available and if so any added charge).
Color: Plain Black (indicate if other colors are available and if so any added charge) 42
Gould&Goodrich
Model B191

Item	Description	Total	Unit Price	Extended Price
1	Nylon Duty Belt	250	\$27.86	\$6965.00
2	Buckleless Pants Belt	193	\$15.12	\$2918.16
3	Nylon Dbl Mag Pouch	366	\$20.18	\$7385.88
4	Nylon Single Mag Pouch	1	\$11.11	\$11.11
5	Nylon Single Cuff Pouch	218	\$15.12	\$3296.16
6	Nylon Double Cuff Pouch	1	\$17.82	\$17.82
7	Nylon OC Spray Pouch	205	\$13.12	\$2689.60
8	Nylon Baton Pouch	221	\$13.12	\$2899.52
9	Nylon Glove/Shield Pouch	224	\$13.12	\$2938.88
10	Dbl Mag Pouch Conceal	26	\$21.86	\$568.36
11	Cuff Case Conceal	42	\$17.95	\$753.90
12	Plainclothes Belt	42	\$34.23	\$1437.06
			SUBTOTAL	\$31882.05

U.S. Cavalry Store, Inc.
2855 Centennial Ave.
Radcliff, KY 40160

WVDOC Specifications for holsters & Accessories

Item Number	Description	Projected Quantity
1	Blackhawk Level 3 Duty SERPA Auto Lock Holster, or equal; must fit Glock 21SF pistol with standard Glock Rail Color: Matte Black	350 Blackhawk (44H113BK) Bid as specified
2	Blackhawk CQC Level 2 SERPA Concealment Holster, or equal; must fit Glock 21SF pistol with standard Glock Rail Color: Matte Black	50 Blackhawk (410513BK) Bid as specified
3	Blackhawk Level 2 Tactical SERPA Holster ("Y" leg Harness, or equal; configuration must fit Glock 21SF pistol with standard Glock Rail Color: Matte Black	100 Blackhawk (430513BK) Bid as specified
4	Blackhawk S.T.R.I.K.E./MOLLE speed clip CQC Platform, or equal; must work for mounting holsters on load bearing vests Color: Black Matte	50 Blackhawk (38CL63BK) Bid as specified

Item	Description	Total	Unit Price	Extended Price
1	Auto lock holster	350	\$60.74	\$21259.00
2	Concealment holster	50	\$29.14	\$1457.00
3	Y leg harness	100	\$76.54	\$7654.00
4	Speed clip	50	\$9.82	\$491.00
			SUBTOTAL	\$30861.00

GRAND TOTAL \$62,743.05

Notes:

1. "Or Equal" substitutions: The vendor is responsible to submit one non-returnable sample item upon request for each and any item the vendor chooses to substitute an "equal" for the specified make and model so that an assessment can be made by the Director of Security or Designee that the substituted item meets specifications.
2. Above specified items are already standard issue items for WVDOC Correctional Officers, Parole Officers and Investigators.
3. The agency reserves the right to award this contract in whole or in part.

U.S. Cavalry Store, Inc.
2855 Centennial Ave.
Radcliff, KY 40160

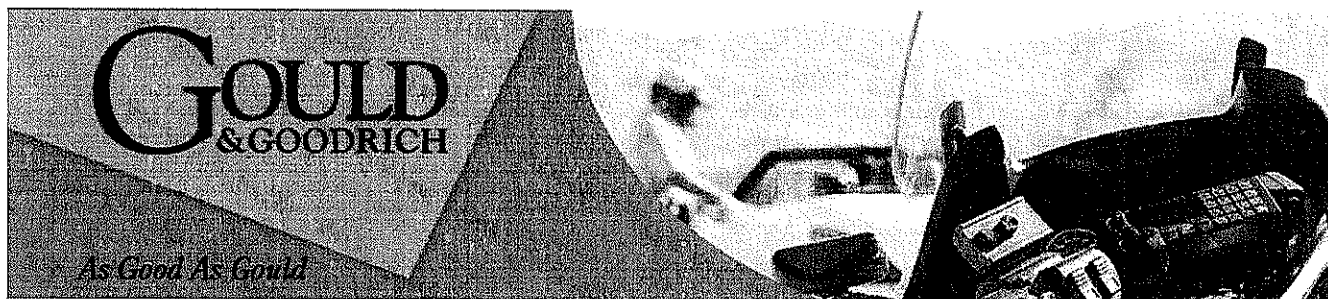

[NEW PRODUCTS](#) | [PRODUCTS](#) | [ABOUT US](#) | [NEWS & EVENTS](#) | [CATALOG](#) | [CONTACT](#)

Product Line

[Gold Line Concealment
Holsters, Belts & Accessories](#)

[Other Concealment Holsters](#)

[Leather Duty Holsters](#)

[K-Force Duty Holsters](#)

[Taser & Stinger Holsters &
Accessories](#)

[Leather Duty Belts &
Accessories](#)

[K-Force Duty Belts &
Accessories](#)

[Phoenix Duty Nylon Holsters,
Belts & Accessories](#)

[Search](#)

[Where to Buy](#)

[Warnings, Safety &
Consumer Information](#)

Phoenix Duty Nylon Holsters, Belts & Accessories

Durable, reliable and fit for a professional. The only no-compromise duty nylon. We fuse strong ballistic nylon to a hard Kydex core, then precision mold it to maintain its shape and performance. This is Phoenix Duty Nylon. It outlasts other nylon gear because we use no foam, so Phoenix Duty Nylon never suffers foam breakdown.

Phoenix Duty Nylon holsters are designed for ease of use and are available in adjustable tension, double retention or triple retention styles. Duty belts have a patented grab-resistant buckle. They won't crush or roll, and they provide a firm platform for a smooth holster draw. Accessory pouches are crush-proof; they remain open for easy re-holstering.

Though lighter in weight, Phoenix Duty Nylon is engineered with the same performance standards as our leather and K-Force duty products. With durable edge bindings and no-shine black snaps, Phoenix Duty Nylon is the most reliable and professional looking nylon duty gear you can wear. Committed to excellence. As good as Gould.

Phoenix Duty Nylon



Holsters, Belts & Accessories

Browse our selection of Phoenix Duty Nylon Holsters, Belts & Accessories:

[Adjustable Tension Holster](#)
[Aerosol Holders](#)
[Baton Holders](#)
[Belt Keepers](#)
[Double Retention Duty Nylon Holster](#)
[Double Retention Quantum Duty Nylon Holster](#)
[Flashlight Holders](#)
[Glove Case](#)
[Handcuff Cases](#)
[Holster For Weapons W/Tactical Lights](#)
[Key Holders](#)
[Magazine Cases & Speedloader Case](#)
[Radio Swivel Belt Loop](#)
[Radio, Pager & Cell Phone Holders](#)
[Sam Browne Duty Belt Buckle](#)
[Sam Browne Duty Belts & Pants Belts](#)
[Triple Retention Duty Nylon Holster](#)
[Triple Retention Quantum Holster](#)
[View all](#)

© Copyright Gould & Goodrich, Inc. 2008. All rights reserved. International copyright secured.

U.S. Cavalry Store, Inc.
 2855 Centennial Ave.
 Radcliff, KY 40160

Perimeter Booth

A Perimeter Booth is a Linear Booth that backs to an outside wall of the exhibit facility rather than to another exhibit.

Dimensions and Use of Space

All guidelines for Linear Booths apply to Perimeter Booths except that the typical maximum back wall height is 12ft (3.66m).

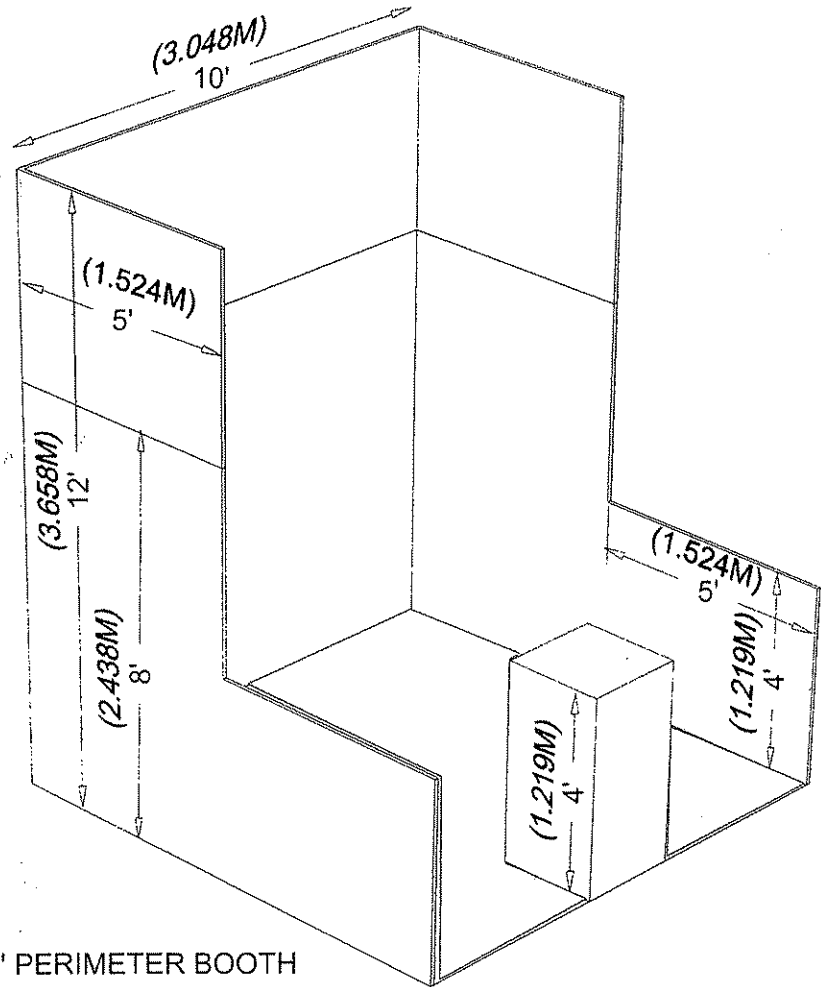
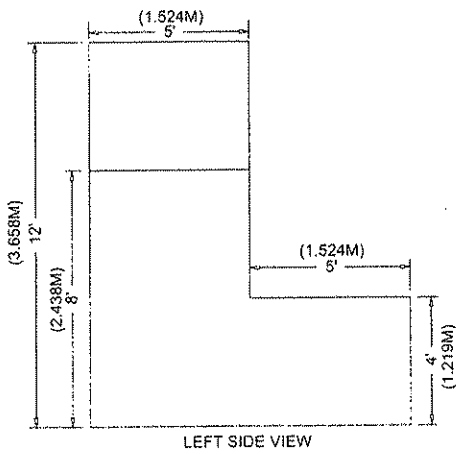
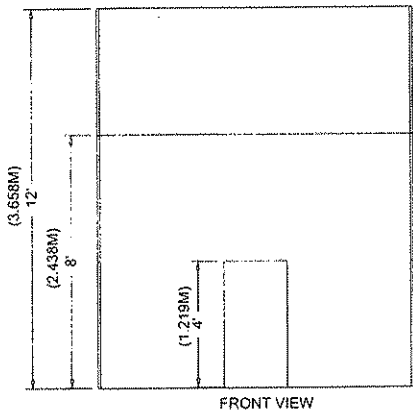
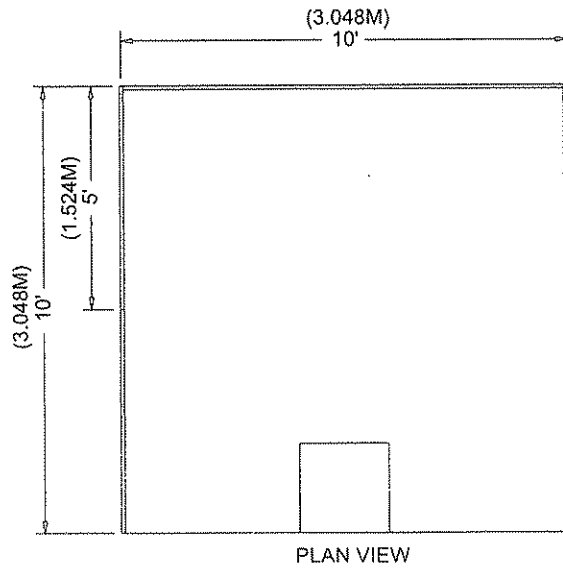

Duty accessories fit on belts up to 2 1/4".

SAM BROWNE DUTY BELTS & PANTS BELTS

X54 or X50 Velcro Lined Duty Belt With Grab-Resistant Buckle

Exclusive grab-resistant buckle helps prevent an assailant from unbuckling your duty belt and stealing your gear. The wearer can easily release this buckle. But it's hard for an assailant to push the hidden release tabs.

- Full 2 1/4" width plus reinforcement inside belt for a firm holster platform
- Full Velcro lining interlocks with X55 Velcro lined pants belt for more stability and comfort
- X54 features handsome edge binding
- X50 features strong DuraWeb™ nylon
- Stocked in SM (28 to 32"), MD (34 to 38"), LG (40 to 44"), XL (46 to 50"), XXL (52 to 56")

X55 Buckleless Velcro Lined Pants Belt

- 1 1/2", fully lined in Velcro
- Velcro interlocks with X54 or X50 Sam Browne Duty Belt for more stability and comfort
- Stocked in SM (28 to 32"), MD (34 to 38"), LG (40 to 44"), XL (46 to 50"), XXL (52 to 56")

B2001 Buckleless Velcro Closure Pants Belt

- 1 1/2" with Velcro closure
- Stocked in SM (28 to 32"), MD (34 to 38"), LG (40 to 44"), XL (46 to 50"), XXL (52 to 56")

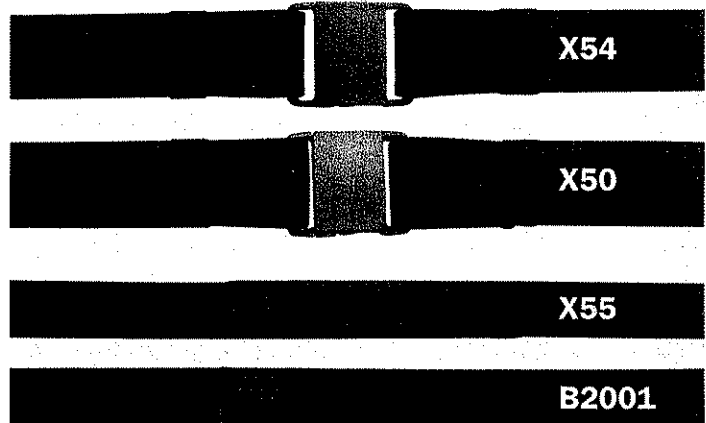

KEY HOLDERS

X598 Silent Key Holder

- Adjustable Velcro closure

X122 Key strap

- Easy to snap on, easy to snap off belt

X598

X122

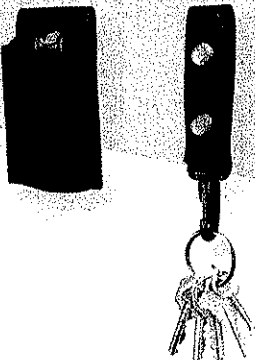

AEROSOL HOLDERS

B2058 Aerosol Holder

- Holds MK VI aerosol

X681-3 Aerosol Case

- Holds MK III, MK XI, or Sabre Red MK-3

X681-4 Aerosol Case

- Holds MK IV, MK XII, Body Guard B-10-5 4 oz. fogger top aerosol or Sabre Red MK4 4.4oz

B2058

X681-3

X681-4



U.S. Cavalry Store, Inc.
2855 Centennial Ave.
Radcliff, KY 40160

GOULD
& GOODRICH

800.277.0732 or www.GouldUSA.com

HANDCUFF & MAGAZINE CASE COMBO



B841 Belt Loop Style (Back)



B821 Paddle Style (Back)

Gold Line Accessories:
Choose Paddle or Belt Loop Style

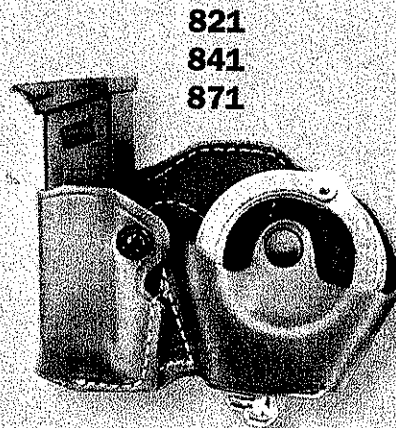

**821
841
871**

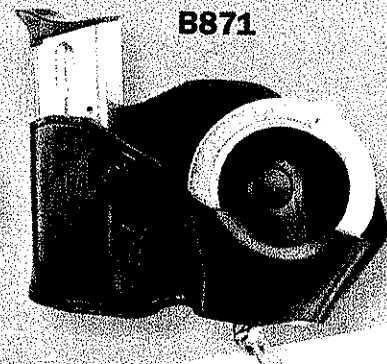

**B821
B841
B871**

821 Paddle Style and B821 Paddle Style
841 Belt Loop Style and B841 Belt Loop Style
871 Belt Loop Style and B871 Belt Loop Style

- Tension screw lets you adjust for a firm or easier draw
 - 821, B821, 841, B841 all hold most chain or hinged cuffs
 - For ASP Tactical Chain Cuffs, order 871 Brown Paddle Style or B871 Black Paddle Style
 - In right- or left-hand versions
- Chestnut Brown or Black**

HANDCUFF CASE

**820
840
870**

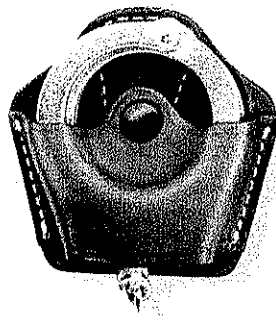

**B820
B840
B870**

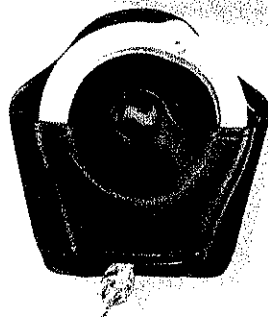

820 Paddle Style and B820 Paddle Style
840 Belt Loop Style and B840 Belt Loop Style
870 Belt Loop Style and B870 Belt Loop Style

- 820, B820, 840, B840 all hold most chain or hinged cuffs
- For ASP Tactical Chain Cuffs, order 870 Brown Paddle Style or B870 Black Paddle Style

Chestnut Brown or Black

FLASHLIGHT & MAGAZINE CASE COMBO

860

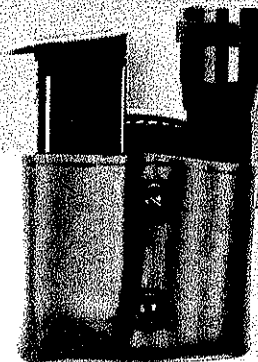

B860

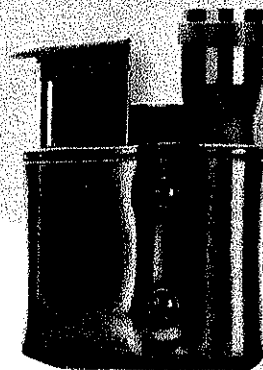

860 and B860

- Two styles...one case. Can be worn as paddle style or belt loop style. Simply remove paddle to reveal belt loop.
- Tension screw lets you adjust for a firm or easier draw
- Holds Streamlight Scorpion flashlight

Chestnut Brown or Black

U.S. Cavalry Store, Inc.
2855 Centennial Ave.
Radcliff, KY 40160

GOULD
& GOODRICH

800.277.0732 or www.GouldUSA.com

Phoenix Duty Nylon

HANDCUFF CASES

X70 Handcuff Case

- Holds most chain cuffs

X71 Handcuff Case

- Holds most hinged cuffs

X470 Handcuff Case

- Holds ASP Tactical Chain Cuffs

X596 Double Handcuff Case

- Holds two pair chain or hinged cuffs
- Snap and Velcro closure together for added security

X670 Handcuff Case

- Holds S&W Model 1 (large) chain or hinged handcuffs

**X70
X71**

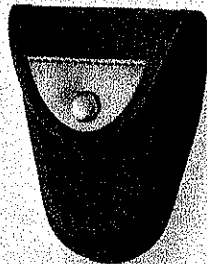

X470



X596

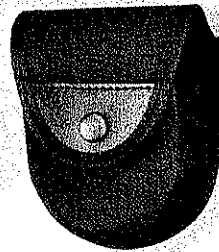

X670



BELT KEEPERS

B2099 Double Snap Keeper

B2071 Velcro Keeper

- Velcro closure

B2096 Hidden Cuff Key Keeper

- Includes hidden cuff key

B2099

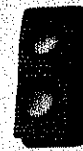

B2071



B2096



U.S. Cavalry Store, Inc.
2855 Centennial Ave.
Radcliff, KY 40160

MAGAZINE & SPEEDLOADER CASES

X647 Adjustable Tension Double Magazine Case

- Tension screw allows adjustment for firm or easier draw
- Wide spacing and low-cut sides to easily grip magazines
- For vertical or horizontal carry
- Specify weapon make, model and version or see our latest Magazine Case Will-Fit Chart for size

X647

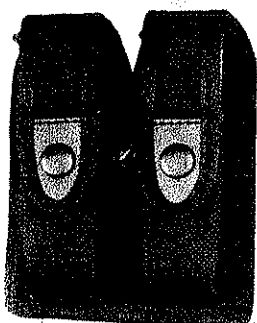

X627 Double Magazine Case

- Specify weapon make, model and version or see our latest Magazine Case Will-Fit Chart for size
- For vertical or horizontal carry

X627

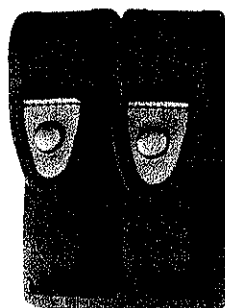

X628



X628 Single Magazine Case

- Specify weapon make, model and version or see our latest Magazine Case Will-Fit Chart for size
- For vertical carry

X617

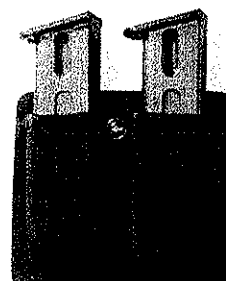

X617 Open Top Magazine Pouch

- Tension screw allows adjustment for firm or easier draw
- Wide spacing and low-cut sides to easily grip magazines
- Vertical carry only and has no snap
- Specify weapon make, model and version or see our latest Magazine Case Will-Fit Chart for size

X162 Double Speedloader Case

- Holds loaders in separate pockets
- Foam padded for quiet carry
- For COLT King Cobra, Python, Trooper; RUGER GP100, Security Six; S&W K-frame Model 10, 13, 19, 64, 65, 66, L-frame Model 586, 686

X162

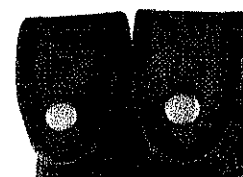

BATON HOLDERS

X560-21 Or X560-26

Expandable Baton Holders

- Size 21 holds expandable 16" or 21" foam handle baton
- Size 26 holds expandable 26" foam handle baton
- With automatic tension system

B2070 PR24 Baton Holder

- Holds PR24 or PR24S

B2056 Baton Holder

- Holds standard wood baton, or "C" cell or Streamlight Stinger flashlight
- Black ring

X560-21



X560-26



B2070



B2056



GLOVE CASE

X555 Two-pocket Glove Case

- Slim, patented design slides comfortably into pocket or fits on belt
- Holds two pair surgical gloves in separate pockets

X555

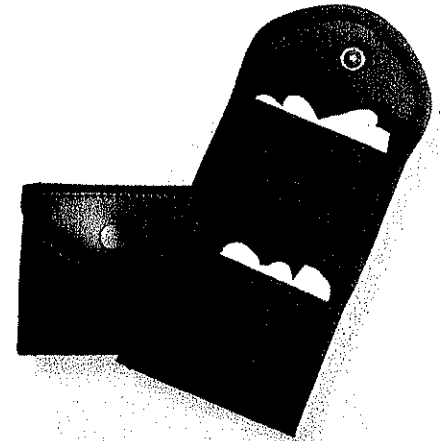

U.S. Cavalry Store, Inc.
2855 Centennial Ave.
Radcliff, KY 40160

RADIO & MICROPHONE HOLDERS

X651-1 Universal Radio Case

or

X652-1 Quick Release Universal Radio Case With Swivel

- Fits most popular radios
- Elastic tie-down with snap adjusts to hold radios of various heights
- Mid-ride so even a tall radio won't dig into your ribs or back
- 1 1/2"D x 2 3/4"W x 7 1/2"H
- X652-1 radio case has two-piece belt mount that swivels; case may be detached from belt loop

K653 Swivel Belt Loop

- Holds radios equipped with Motorola standard male attachment
- Also holds radio cases equipped with Motorola standard male attachment, including our model X652-1

X654 New Radio Case

- Velcro closure adjusts to fit most popular radios
- "L" shape base made of heavy-duty steel for extra durability

K616 Epaulet Microphone Holder

- Attach holder to epaulet
- Attach microphone to holder
- Offers snap, Velcro and strong polymer loop to hold all popular microphone styles

X588 Pager/Glove Case

- Holds pager up to 3 1/2" H x 2" W x 1 1/8" D
- Holds 3 pair surgical gloves

K616

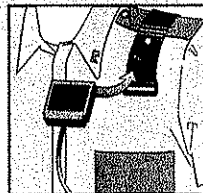

X651-1 X652-1

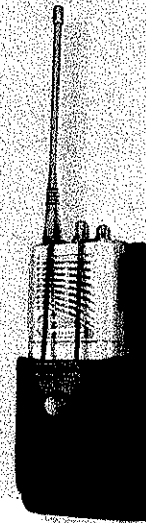

K653



X654



X588



Duty accessories fit on belts up to 2 1/4".

For Gold Line items in Black, order using model numbers beginning with "B". For Chestnut Brown, order using model numbers without "B".

For magazine case styles, specify weapon make, model and version. Paddle style Gold Line accessories fit over belts up to 1 3/4" or clip over waistband. Belt loops on Gold Line accessories fit belts up to 1 3/4".

DOUBLE MAGAZINE CASE

831
851

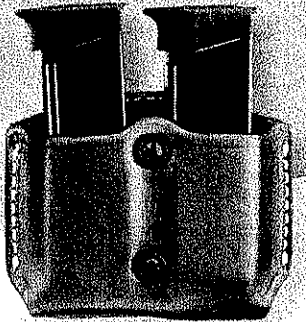

B831
B851

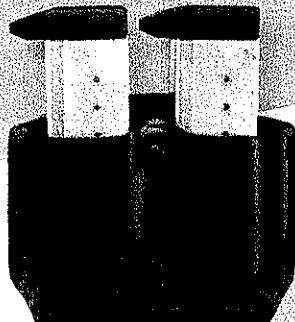

831 Paddle Style and B831 Paddle Style
851 Belt Loop Style and B851 Belt Loop Style

· Tension screw lets you adjust for a firm or easier draw
Chestnut Brown or Black

SINGLE MAGAZINE CASE

830
850



B830
B850

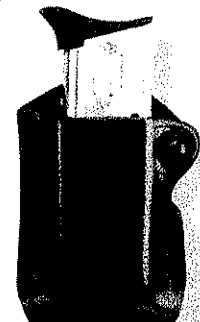

830 Paddle Style and B830 Paddle Style
850 Belt Loop Style and B850 Belt Loop Style

· Tension screw lets you adjust for a firm or easier draw
Chestnut Brown or Black

REINFORCED DRESS BELT

191, 190, B191, B190

This belt is a "must" for concealed weapon carry. It won't sag with the weight of a holster and weapon. It provides a firm platform for carrying your holster comfortably, drawing your weapon consistently. Removable solid brass buckle.

· For 1 1/4" belt, order 190 or B190
· For 1 1/2" belt, order 191 or B191

Chestnut Brown or Black

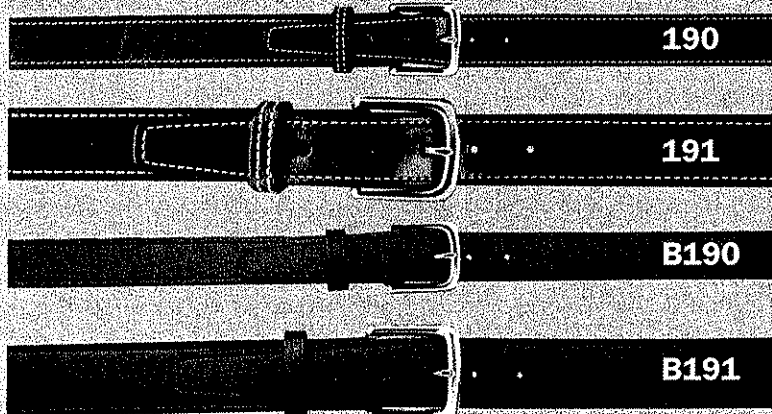

U.S. Cavalry Store, Inc.
2855 Centennial Ave.
Radcliff, KY 40160

U.S. CAVALRY



Many Missions. ONE SOURCE!

2855 Centennial Ave • Radcliff KY 40160-9000

Tel: 1.800.777.7172 • Fax: 270.352.0266

Web: www.uscav.com

April 27, 2009

Mr. John Abbott
Department of Administration
Purchasing Division
Building 15
2019 Washington Street, East
Charleston, WV 25305-0130

Re: RFO # COR61405 (April 28, 2009 1:30PM)

Dear Mr. John Abbott:

Please accept the attached documentation representing the bid presentation on behalf of U.S. Cavalry in connection with the referenced bid.

We respectfully request a tabulation of the bid referenced above. An enclosed, self addressed, self stamped envelope has been attached to the bid documentation.

Thank you in advance.

Respectfully,

A handwritten signature in cursive script that reads "David R. Valinski". The signature is written in black ink and is positioned above the typed name.

David R. Valinski
Contract Sales
U.S. Cavalry Store, Inc.

Attachment: (1) Bid documentation (COR61405)
(2) Self Stamped, Self Addressed return envelop

VENDOR PREFERENCE CERTIFICATE

Certification and application* is hereby made for Preference in accordance with *West Virginia Code*, §5A-3-37. (Does not apply to construction contracts). *West Virginia Code*, §5A-3-37, provides an opportunity for qualifying vendors to request (at the time of bid) preference for their residency status. Such preference is an evaluation method only and will be applied only to the cost bid in accordance with the *West Virginia Code*. This certificate for application is to be used to request such preference. The Purchasing Division will make the determination of the Resident Vendor Preference, if applicable. No preference is requested

1. Application is made for 2.5% resident vendor preference for the reason checked:
 Bidder is an individual resident vendor and has resided continuously in West Virginia for four (4) years immediately preceding the date of this certification; or,
 Bidder is a partnership, association or corporation resident vendor and has maintained its headquarters or principal place of business continuously in West Virginia for four (4) years immediately preceding the date of this certification; or 80% of the ownership interest of Bidder is held by another individual, partnership, association or corporation resident vendor who has maintained its headquarters or principal place of business continuously in West Virginia for four (4) years immediately preceding the date of this certification; or,
 Bidder is a nonresident vendor which has an affiliate or subsidiary which employs a minimum of one hundred state residents and which has maintained its headquarters or principal place of business within West Virginia continuously for the four (4) years immediately preceding the date of this certification; or,
2. Application is made for 2.5% resident vendor preference for the reason checked:
 Bidder is a resident vendor who certifies that, during the life of the contract, on average at least 75% of the employees working on the project being bid are residents of West Virginia who have resided in the state continuously for the two years immediately preceding submission of this bid; or,
3. Application is made for 2.5% resident vendor preference for the reason checked:
 Bidder is a nonresident vendor employing a minimum of one hundred state residents or is a nonresident vendor with an affiliate or subsidiary which maintains its headquarters or principal place of business within West Virginia employing a minimum of one hundred state residents who certifies that, during the life of the contract, on average at least 75% of the employees or Bidder's affiliate's or subsidiary's employees are residents of West Virginia who have resided in the state continuously for the two years immediately preceding submission of this bid; or,
4. Application is made for 5% resident vendor preference for the reason checked:
 Bidder meets either the requirement of both subdivisions (1) and (2) or subdivision (1) and (3) as stated above; or,
5. Application is made for 3.5% resident vendor preference who is a veteran for the reason checked:
 Bidder is an individual resident vendor who is a veteran of the United States armed forces, the reserves or the National Guard and has resided in West Virginia continuously for the four years immediately preceding the date on which the bid is submitted; or,
6. Application is made for 3.5% resident vendor preference who is a veteran for the reason checked:
 Bidder is a resident vendor who is a veteran of the United States armed forces, the reserves or the National Guard, if, for purposes of producing or distributing the commodities or completing the project which is the subject of the vendor's bid and continuously over the entire term of the project, on average at least seventy-five percent of the vendor's employees are residents of West Virginia who have resided in the state continuously for the two immediately preceding years.

Bidder understands if the Secretary of Revenue determines that a Bidder receiving preference has failed to continue to meet the requirements for such preference, the Secretary may order the Director of Purchasing to: (a) reject the bid; or (b) assess a penalty against such Bidder in an amount not to exceed 5% of the bid amount and that such penalty will be paid to the contracting agency or deducted from any unpaid balance on the contract or purchase order.

By submission of this certificate, Bidder agrees to disclose any reasonably requested information to the Purchasing Division and authorizes the Department of Revenue to disclose to the Director of Purchasing appropriate information verifying that Bidder has paid the required business taxes, provided that such information does not contain the amounts of taxes paid nor any other information deemed by the Tax Commissioner to be confidential.

Under penalty of law for false swearing (*West Virginia Code*, §61-5-3), Bidder hereby certifies that this certificate is true and accurate in all respects; and that if a contract is issued to Bidder and if anything contained within this certificate changes during the term of the contract, Bidder will notify the Purchasing Division in writing immediately.

Bidder: U.S. Cavalry Store, Inc. Signed: *David A. Alensti*

Date: 27 April 2009 Title: Contract Sales Director

*Check any combination of preference consideration(s) indicated above, which you are entitled to receive.

U.S. Cavalry Store, Inc.
 2855 Centennial Ave.
 Radcliff, KY 40160

STATE OF WEST VIRGINIA
Purchasing Division**PURCHASING AFFIDAVIT****VENDOR OWING A DEBT TO THE STATE:**

West Virginia Code §5A-3-10a provides that: No contract or renewal of any contract may be awarded by the state or any of its political subdivisions to any vendor or prospective vendor when the vendor or prospective vendor or a related party to the vendor or prospective vendor is a debtor and the debt owed is an amount greater than one thousand dollars in the aggregate.

PUBLIC IMPROVEMENT CONTRACTS & DRUG-FREE WORKPLACE ACT:

If this is a solicitation for a public improvement construction contract, the vendor, by its signature below, affirms that it has a written plan for a drug-free workplace policy in compliance with Article 1D, Chapter 21 of the *West Virginia Code*. The vendor **must** make said affirmation with its bid submission. Further, public improvement construction contract may not be awarded to a vendor who does not have a written plan for a drug-free workplace policy in compliance with Article 1D, Chapter 21 of the *West Virginia Code* and who has not submitted that plan to the appropriate contracting authority in timely fashion. For a vendor who is a subcontractor, compliance with Section 5, Article 1D, Chapter 21 of the *West Virginia Code* may take place before their work on the public improvement is begun.

ANTITRUST:

In submitting a bid to any agency for the state of West Virginia, the bidder offers and agrees that if the bid is accepted the bidder will convey, sell, assign or transfer to the state of West Virginia all rights, title and interest in and to all causes of action it may now or hereafter acquire under the antitrust laws of the United States and the state of West Virginia for price fixing and/or unreasonable restraints of trade relating to the particular commodities or services purchased or acquired by the state of West Virginia. Such assignment shall be made and become effective at the time the purchasing agency tenders the initial payment to the bidder.

I certify that this bid is made without prior understanding, agreement, or connection with any corporation, firm, limited liability company, partnership or person or entity submitting a bid for the same materials, supplies, equipment or services and is in all respects fair and without collusion or fraud. I further certify that I am authorized to sign the certification on behalf of the bidder or this bid.

LICENSING:

Vendors must be licensed and in good standing in accordance with any and all state and local laws and requirements by any state or local agency of West Virginia, including, but not limited to, the West Virginia Secretary of State's Office, the West Virginia Tax Department, West Virginia Insurance Commission, or any other state agencies or political subdivision. Furthermore, the vendor must provide all necessary releases to obtain information to enable the Director or spending unit to verify that the vendor is licensed and in good standing with the above entities.

CONFIDENTIALITY:

The vendor agrees that he or she will not disclose to anyone, directly or indirectly, any such personally identifiable information or other confidential information gained from the agency, unless the individual who is the subject of the information consents to the disclosure in writing or the disclosure is made pursuant to the agency's policies, procedures and rules. Vendor further agrees to comply with the Confidentiality Policies and Information Security Accountability Requirements, set forth in <http://www.state.wv.us/admin/purchase/privacy/noticeConfidentiality.pdf>.

Under penalty of law for false swearing (*West Virginia Code* §61-5-3), it is hereby certified that the vendor affirms and acknowledges the information in this affidavit and is in compliance with the requirements as stated.

Vendor's Name: U.S. Cavalry Store, Inc

Authorized Signature: David Salimbi Date: 27 April 2009

Purchasing Affidavit (Revised 01/01/09)

U.S. Cavalry Store, Inc.
2855 Centennial Ave.
Radcliff, KY 40160