



State of West Virginia
 Department of Administration
 Purchasing Division
 2019 Washington Street East
 Post Office Box 50130
 Charleston, WV 25305-0130

Request for Quotation

RFQ NUMBER
COR61403

PAGE
1

ADDRESS CORRESPONDENCE TO ATTENTION OF
JOHN ABBOTT 304-558-2544

VENDOR

RFQ COPY
 TYPE NAME/ADDRESS HERE

Danhill Construction Company
 PO Box 685
 Gauley Bridge, WV 25085

SHIP TO

HUTTONSVILLE CORRECTIONAL
 CENTER
 ATTENTION: KEN HOLBROOK
 ROUTE 250 SOUTH
 HUTTONSVILLE, WV
 26273 335-2291

DATE PRINTED	TERMS OF SALE	SHIP VIA	F.O.B.	FREIGHT TERMS
03/13/2009				

BID OPENING DATE: 04/15/2009 BID OPENING TIME 01:30PM

LINE	QUANTITY	UOP	CAT NO	ITEM NUMBER	UNIT PRICE	AMOUNT
001	1	LS		968-20		\$85,800.00
GUARD BUILDING AND TOWER CONTRACT TO PROVIDE ALL LABOR, MATERIALS, AND EQUIPMENT NECESSARY TO INSTALL A GUARD HOUSE AND GUARD TOWER AT THE HUTTONSVILLE CORRECTIONAL CENTER, PER THE SPECIFICATIONS. MANDATORY ON-SITE PRE-BID: HUTTONSVILLE CORRTL. CNTR. RT. 250 HUTTONSVILLE, WV 26273 4/1/09; 1:30 PM EXHIBIT 5 WEST VIRGINIA CODE 21-1D-5 PROVIDES THAT: ANY SOLICITATION FOR A PUBLIC IMPROVEMENT CONSTRUCTION CONTRACT REQUIRES EACH VENDOR THAT SUBMITS A BID FOR THE WORK TO SUBMIT AT THE SAME TIME AN AFFIDAVIT OF COMPLIANCE WITH THE BID. THE ENCLOSED DRUG-FREE WORKPLACE AFFIDAVIT MUST BE SIGNED AND SUBMITTED WITH THE BID AS EVIDENCE OF THE VENDOR'S COMPLIANCE WITH THE PROVISIONS OF ARTICLE 1D, CHAPTER 21 OF THE WEST VIRGINIA CODE. FAILURE TO SUBMIT THE SIGNED DRUG-FREE WORKPLACE AFFIDAVIT WITH THE BID SHALL RESULT IN DISQUALIFICATION OF SUCH BID. NOTICE TO PROCEED: THIS CONTRACT IS TO BE PERFORMED WITHIN 45 CALENDAR DAYS AFTER THE NOTICE TO PROCEED IS RECEIVED. UNLESS OTHERWISE SPECIFIED, THE FULLY EXECUTED PURCHASE ORDER WILL BE CONSIDERED NOTICE TO PROCEED.						

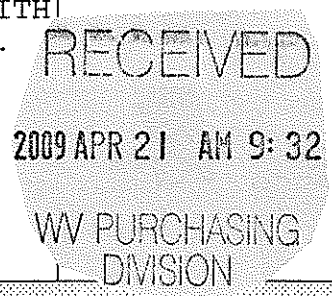

SEE REVERSE SIDE FOR TERMS AND CONDITIONS		
SIGNATURE <i>Robert D. Hill</i>	TELEPHONE 304-632-1600	DATE 4-21-09
TITLE <i>Proc</i>	FEIN 55-0648251-	ADDRESS CHANGES TO BE NOTED ABOVE

WHEN RESPONDING TO RFQ, INSERT NAME AND ADDRESS IN SPACE ABOVE LABELED 'VENDOR'

**GENERAL TERMS & CONDITIONS
REQUEST FOR QUOTATION (RFQ) AND REQUEST FOR PROPOSAL (RFP)**

1. Awards will be made in the best interest of the State of West Virginia.
2. The State may accept or reject in part, or in whole, any bid.
3. All quotations are governed by the *West Virginia Code* and the *Legislative Rules* of the Purchasing Division.
4. Prior to any award, the apparent successful vendor must be properly registered with the Purchasing Division and have paid the required \$125 fee.
5. All services performed or goods delivered under State Purchase Order/Contracts are to be continued for the term of the Purchase Order/Contracts, contingent upon funds being appropriated by the Legislature or otherwise being made available. In the event funds are not appropriated or otherwise available for these services or goods, this Purchase Order/Contract becomes void and of no effect after June 30.
6. Payment may only be made after the delivery and acceptance of goods or services.
7. Interest may be paid for late payment in accordance with the *West Virginia Code*.
8. Vendor preference will be granted upon written request in accordance with the *West Virginia Code*.
9. The State of West Virginia is exempt from federal and state taxes and will not pay or reimburse such taxes.
10. The Director of Purchasing may cancel any Purchase Order/Contract upon 30 days written notice to the seller.
11. The laws of the State of West Virginia and the *Legislative Rules* of the Purchasing Division shall govern all rights and duties under the Contract, including without limitation the validity of this Purchase Order/Contract.
12. Any reference to automatic renewal is hereby deleted. The Contract may be renewed only upon mutual written agreement of the parties.
13. **BANKRUPTCY:** In the event the vendor/contractor files for bankruptcy protection, this Contract may be deemed null and void, and terminated without further order.
14. **HIPAA BUSINESS ASSOCIATE ADDENDUM:** The West Virginia State Government HIPAA Business Associate Addendum (BAA), approved by the Attorney General, and available online at the Purchasing Division's web site (<http://www.state.wv.us/admin/purchase/vrc/hipaa.htm>) is hereby made part of the agreement. Provided that, the Agency meets the definition of a Cover Entity (45 CFR §160.103) and will be disclosing Protected Health Information (45 CFR §160.103) to the vendor.
15. **WEST VIRGINIA ALCOHOL & DRUG-FREE WORKPLACE ACT:** If this Contract constitutes a public improvement construction contract as set forth in Article 1D, Chapter 21 of the West Virginia Code ("The West Virginia Alcohol and Drug-Free Workplace Act"), then the following language shall hereby become part of this Contract: "The contractor and its subcontractors shall implement and maintain a written drug-free workplace policy in compliance with the West Virginia Alcohol and Drug-Free Workplace Act, as set forth in Article 1D, Chapter 21 of the West Virginia Code. The contractor and its subcontractors shall provide a sworn statement in writing, under the penalties of perjury, that they maintain a valid drug-free work place policy in compliance with the West Virginia and Drug-Free Workplace Act. It is understood and agreed that this Contract shall be cancelled by the awarding authority if the Contractor: 1) Fails to implement its drug-free workplace policy; 2) Fails to provide information regarding implementation of the contractor's drug-free workplace policy at the request of the public authority; or 3) Provides to the public authority false information regarding the contractor's drug-free workplace policy."

INSTRUCTIONS TO BIDDERS

1. Use the quotation forms provided by the Purchasing Division.
2. **SPECIFICATIONS:** Items offered must be in compliance with the specifications. Any deviation from the specifications must be clearly indicated by the bidder. Alternates offered by the bidder as **EQUAL** to the specifications must be clearly defined. A bidder offering an alternate should attach complete specifications and literature to the bid. The Purchasing Division may waive minor deviations to specifications.
3. Complete all sections of the quotation form.
4. Unit prices shall prevail in case of discrepancy.
5. All quotations are considered F.O.B. destination unless alternate shipping terms are clearly identified in the quotation.
6. **BID SUBMISSION:** All quotations must be delivered by the bidder to the office listed below prior to the date and time of the bid opening. Failure of the bidder to deliver the quotations on time will result in bid disqualifications: Department of Administration, Purchasing Division, 2019 Washington Street East, P.O. Box 50130, Charleston, WV 25305-0130



State of West Virginia
 Department of Administration
 Purchasing Division
 2019 Washington Street East
 Post Office Box 50130
 Charleston, WV 25305-0130

Request for Quotation

RFQ NUMBER
 COR61403

PAGE
 2

ADDRESS CORRESPONDENCE TO ATTENTION OF
 JOHN ABBOTT
 304-558-2544

RFQ COPY

TYPE NAME/ADDRESS HERE

Danhill Construction Company
 PO Box 685
 Gauley Bridge, WV 25085

SHIP TO

HUTTONSVILLE CORRECTIONAL
 CENTER
 ATTENTION: KEN HOLBROOK
 ROUTE 250 SOUTH
 HUTTONSVILLE, WV
 26273 335-2291

DATE PRINTED	TERMS OF SALE	SHIP VIA	F.O.B.	FREIGHT TERMS
03/13/2009				

BID OPENING DATE: 04/15/2009 BID OPENING TIME 01:30PM

LINE	QUANTITY	UOP	CAT. NO.	ITEM NUMBER	UNIT PRICE	AMOUNT
<p>CANCELLATION: THE DIRECTOR OF PURCHASING RESERVES THE RIGHT TO CANCEL THIS CONTRACT IMMEDIATELY UPON WRITTEN NOTICE TO THE VENDOR IF THE MATERIALS OR WORKMANSHIP SUPPLIED ARE OF AN INFERIOR QUALITY OR DO NOT CONFORM WITH THE SPECIFICATIONS OF THE BID AND CONTRACT HERE IN.</p> <p>WAGE RATES: THE CONTRACTOR OR SUBCONTRACTOR SHALL PAY THE HIGHER OF THE U.S. DEPARTMENT OF LABOR MINIMUM WAGE RATES AS ESTABLISHED FOR RANDOLPH COUNTY, PURSUANT TO WEST VIRGINIA CODE 21-5A, ET, SEQ. (PREVAILING WAGE RATES APPLY TO THIS PROJECT)</p> <p>ARBITRATION: ANY REFERENCES MADE TO ARBITRATION OR INTEREST FOR PAYMENTS DUE (EXCEPT FOR ANY INTEREST REQUIRED BY STATE LAW) CONTAINED IN THIS CONTRACT OR IN ANY AMERICAN INSTITUTE OF ARCHITECTS DOCUMENTS PERTAINING TO THIS CONTRACT ARE HEREBY DELETED.</p> <p>WORKERS' COMPENSATION: VENDOR IS REQUIRED TO PROVIDE A CERTIFICATE FROM WORKERS' COMPENSATION IF SUCCESSFUL.</p> <p>ALL OF THE ITEMS CHECKED BELOW WILL BE A REQUIREMENT OF THIS CONTRACT:</p> <p><input checked="" type="checkbox"/> (XX) INSURANCE: SUCCESSFUL VENDOR SHALL FURNISH PROOF OF COMMERCIAL GENERAL LIABILITY INSURANCE PRIOR TO ISSUANCE OF CONTRACT. UNLESS OTHERWISE SPECIFIED IN THE BID DOCUMENTS, THE MINIMUM AMOUNT OF INSURANCE COVERAGE REQUIRED IS \$250,000.</p> <p><input checked="" type="checkbox"/> (XX) BUILDERS RISK INSURANCE: SUCCESSFUL VENDOR SHALL FURNISH PROOF OF BUILDERS RISK - ALL RISK INSURANCE IN AN AMOUNT EQUAL TO 100% OF THE AMOUNT OF THE CONTRACT.</p>						

SEE REVERSE SIDE FOR TERMS AND CONDITIONS

SIGNATURE <i>Robert D. Hill</i>	TELEPHONE 304-632-1600	DATE 4/21/09
TITLE President	FEIN 55-0648251	ADDRESS CHANGES TO BE NOTED ABOVE

WHEN RESPONDING TO RFQ, INSERT NAME AND ADDRESS IN SPACE ABOVE LABELED 'VENDOR'



State of West Virginia
 Department of Administration
 Purchasing Division
 2019 Washington Street East
 Post Office Box 50130
 Charleston, WV 25305-0130

Request for Quotation

RFQ NUMBER
COR61403

PAGE
3

ADDRESS CORRESPONDENCE TO ATTENTION OF
JOHN ABBOTT 304-558-2544

VENDOR

RFQ COPY
 TYPE NAME/ADDRESS HERE

Danhill Construction Company
 PO Box 685
 Gauley Bridge, WV 25085

SHIP TO

HUTTONSVILLE CORRECTIONAL
 CENTER
 ATTENTION: KEN HOLBROOK
 ROUTE 250 SOUTH
 HUTTONSVILLE, WV
 26273 335-2291

DATE PRINTED	TERMS OF SALE	SHIP VIA	F.O.B.	FREIGHT TERMS
03/13/2009				

BID OPENING DATE: 04/15/2009 BID OPENING TIME 01:30PM

LINE	QUANTITY	UOP	CAT NO.	ITEM NUMBER	UNIT PRICE	AMOUNT
✓				(XX) BONDS: FIVE PERCENT (5%) OF THE TOTAL AMOUNT OF THE BID PAYABLE TO THE STATE OF WEST VIRGINIA, SHALL BE SUBMITTED WITH EACH BID AS A BID BOND. THE SUCCESSFUL BIDDER SHALL ALSO FURNISH A PERFORMANCE BOND AND LABOR/MATERIAL BOND FOR 100% OF THE AMOUNT OF THE CONTRACT. BONDS MAY BE PROVIDED IN THE FORM OF A CERTIFIED CHECK IRREVOCABLE LETTER OF CREDIT, OR BOND FURNISHED BY A SOLVENT SURETY COMPANY AUTHORIZED TO DO BUSINESS IN THE STATE OF WEST VIRGINIA. A LETTER OF CREDIT SUBMITTED IN LIEU OF A BOND WILL ONLY BE ALLOWED FOR PROJECTS UNDER \$100,000. PERSONAL OR BUSINESS CHECKS ARE NOT ACCEPCTABLE IN LIEU OF THE 5% BID BOND, PERFORMANCE BOND, OR LABOR AND MATERIAL BOND.		
✓				(XX) MAINTENANCE BOND: A TWO (2) YEAR MAINTENANCE BOND COVERING THE ROOFING SYSTEM WILL BE A REQUIREMENT OF THE SUCCESSFUL VENDOR.		
				REV. 11/00		
				EXHIBIT 7		
				DOMESTIC ALUMINUM, GLASS & STEEL IN PUBLIC WORKS PROJECTS		
				IN ACCORDANCE WITH WEST VIRGINIA CODE 5-19-1 ET., SEQ., EVERY CONTRACT FOR CONSTRUCTION, RECONSTRUCTION, ALTERATION, REPAIR, IMPROVEMENT OR MAINTENANCE OF PUBLIC WORKS, WHERE THE COST IS MORE THAN \$50,000 AND, IN THE CASE OF STEEL ONLY, WHERE THE COST OF STEEL IS MORE THAN \$50,000 OR WHERE MORE THAN 10,000 POUNDS OF STEEL ARE REQUIRED, THE STATE WILL ACCEPT ONLY ALUMINUM GLASS, OR STEEL PRODUCTS PRODUCED IN THE UNITED STATES. IN ADDITION, ITEMS OF MACHINERY OR EQUIPMENT PURCHASED FOR USE AT THE SITE OF PUBLIC WORKS SHALL BE MADE OF		

SEE REVERSE SIDE FOR TERMS AND CONDITIONS

SIGNATURE	TELEPHONE	DATE
Robert D. Hill	304-632-1600	4/21/09

TITLE	FEN	ADDRESS CHANGES TO BE NOTED ABOVE
President	55-0648251	

WHEN RESPONDING TO RFQ, INSERT NAME AND ADDRESS IN SPACE ABOVE LABELED 'VENDOR'



State of West Virginia
 Department of Administration
 Purchasing Division
 2019 Washington Street East
 Post Office Box 50130
 Charleston, WV 25305-0130

Request for Quotation

RFQ NUMBER
 COR61403

PAGE
 4

ADDRESS CORRESPONDENCE TO ATTENTION OF
 JOHN ABBOTT
 304-558-2544

VENDOR

RFQ COPY
 TYPE NAME/ADDRESS HERE

Danhill Construction Company
 PO Box 685
 Gauley Bridge, WV 25085

SHIP TO

HUTTONSVILLE CORRECTIONAL
 CENTER
 ATTENTION: KEN HOLBROOK
 ROUTE 250 SOUTH
 HUTTONSVILLE, WV
 26273 335-2291

DATE PRINTED	TERMS OF SALE	SHIP VIA	F.O.B.	FREIGHT TERMS
03/13/2009				

BID OPENING DATE: 04/15/2009 BID OPENING TIME 01:30PM

LINE	QUANTITY	UOP	CAT. NO.	ITEM NUMBER	UNIT PRICE	AMOUNT
<p>DOMESTIC ALUMINUM, GLASS OR STEEL, UNLESS THE COST OF THE PRODUCT IS LESS THAN \$50,000 OR LESS THAN 10,000 POUNDS OF STEEL ARE USED IN PUBLIC WORKS PROJECTS.</p> <p>FOREIGN MADE ALUMINUM, GLASS OR STEEL PRODUCTS MAY BE ACCEPTED ONLY IF THE COST OF DOMESTIC PRODUCTS IS FOUND TO BE UNREASONABLE. SUCH COST IS UNREASONABLE IF IT IS 20% OR MORE HIGHER THAN THE BID PRICE FOR FOREIGN MADE PRODUCTS. IF THE DOMESTIC ALUMINUM, GLASS OR STEEL PRODUCTS TO BE SUPPLIED OR PRODUCED IN A "SUBSTANTIAL LABOR SURPLUS AREA", AS DEFINED BY THE UNITED STATES DEPARTMENT OF LABOR, FOREIGN PRODUCTS MAY BE SUPPLIED ONLY IF DOMESTIC PRODUCTS ARE 30% OR MORE HIGHER IN PRICE THAN THE FOREIGN MADE PRODUCTS.</p> <p>IF, PRIOR TO THE AWARD OF A CONTRACT UNDER THE ABOVE PROVISIONS, THE SPENDING OFFICER OF THE SPENDING UNIT DETERMINES THAT THERE EXISTS A BID FOR LIKE FOREIGN ALUMINUM, GLASS OR STEEL THAT IS REASONABLE AND LOWER THAN THE LOWEST BID DOMESTIC PRODUCTS, THE SPENDING OFFICE MAY REQUEST, IN WRITING, A REEVALUATION AND REDUCTION IN THE LOWEST BID FOR SUCH DOMESTIC PRODUCTS. ALL VENDORS MUST INDICATE IN THEIR BID IF THEY ARE SUPPLYING FOREIGN ALUMINUM, GLASS OR STEEL.</p> <p>REV. 3/88</p> <p>EXHIBIT 9</p> <p>NOTICE FOR ISSUANCE & ACKNOWLEDGEMENT OF CONSTRUCTION PROJECT ADDENDA</p> <p>THE ARCHITECT/ENGINEER AND/OR AGENCY SHALL BE REQUIRED TO ABIDE BY THE FOLLOWING SCHEDULE IN ISSUING CONSTRUCTION PROJECT ADDENDA FOR STATE AGENCIES:</p>						

SEE REVERSE SIDE FOR TERMS AND CONDITIONS

SIGNATURE	TELEPHONE	DATE
President	304-632-1600	4/21/09
FEIN	ADDRESS CHANGES TO BE NOTED ABOVE	
55-0648201		

WHEN RESPONDING TO RFQ, INSERT NAME AND ADDRESS IN SPACE ABOVE LABELED 'VENDOR'



State of West Virginia
 Department of Administration
 Purchasing Division
 2019 Washington Street East
 Post Office Box 50130
 Charleston, WV 25305-0130

Request for Quotation

RFQ NUMBER
 COR61403

PAGE
 5

ADDRESS CORRESPONDENCE TO ATTENTION OF
 JOHN ABBOTT
 304-558-2544

RFQ COPY
 TYPE NAME/ADDRESS HERE
 Danhill Construction Company
 PO Box 685
 Gauley Bridge, WV 25085

SHIP TO
 HUTTONSVILLE CORRECTIONAL
 CENTER
 ATTENTION: KEN HOLBROOK
 ROUTE 250 SOUTH
 HUTTONSVILLE, WV
 26273 335-2291

DATE PRINTED	TERMS OF SALE	SHIP VIA	FOB	FREIGHT TERMS
03/13/2009				

BID OPENING DATE: 04/15/2009 BID OPENING TIME 01:30PM

LINE	QUANTITY	UOP	CAT. NO.	ITEM NUMBER	UNIT PRICE	AMOUNT
<p>(1) THE ARCHITECT/ENGINEER SHALL PREPARE THE ADDENDUM AND A LIST OF ALL PARTIES THAT HAVE PROCURED DRAWINGS AND SPECIFICATIONS FOR THE PROJECT. THE ADDENDUM AND LIST SHALL BE FORWARDED TO THE BUYER IN THE STATE PURCHASING DIVISION. THE ARCHITECT/ENGINEER SHALL ALSO SEND A COPY OF THE ADDENDUM TO THE STATE AGENCY FOR WHICH THE CONTRACT IS ISSUED.</p> <p>(2) THE BUYER SHALL SEND THE ADDENDUM TO ALL INTERESTED PARTIES AND, IF NECESSARY, EXTEND THE BID OPENING DATE. ANY ADDENDUM SHOULD BE RECEIVED BY THE BUYER WITHIN FOURTEEN (14) DAYS PRIOR TO THE BID OPENING DATE.</p> <p>(3) ALL ADDENDA SHOULD BE FORMALLY ACKNOWLEDGED BY ALL BIDDERS AND SUBMITTED TO THE STATE PURCHASING DIVISION. THE SAME RULES AND REGULATIONS THAT APPLY TO THE ORIGINAL BIDDING DOCUMENT SHALL ALSO APPLY TO AN ADDENDUM DOCUMENT. THE ONLY EXCEPTION MAY BE FOR AN ADDENDUM THAT IS ISSUED FOR THE SOLE PURPOSE OF CHANGING A BID OPENING TIME AND/OR DATE.</p> <p>REV. 11/96</p> <p>EXHIBIT 10</p> <p>ADDENDUM ACKNOWLEDGEMENT</p> <p>I HEREBY ACKNOWLEDGE RECEIPT OF THE FOLLOWING CHECKED ADDENDUM(S) AND HAVE MADE THE NECESSARY REVISIONS TO MY PROPOSAL, PLANS AND/OR SPECIFICATION, ETC.</p> <p>ADDENDUM NOS. :</p>						

SEE REVERSE SIDE FOR TERMS AND CONDITIONS

SIGNATURE: *President* TELEPHONE: 304-632-1600 DATE: 4/21/09

TITLE: *President* FEIN: 55-0648251 ADDRESS CHANGES TO BE NOTED ABOVE

WHEN RESPONDING TO RFQ, INSERT NAME AND ADDRESS IN SPACE ABOVE LABELED 'VENDOR'



State of West Virginia
 Department of Administration
 Purchasing Division
 2019 Washington Street East
 Post Office Box 50130
 Charleston, WV 25305-0130

Request for Quotation

RFQ NUMBER
COR61403

PAGE
6

ADDRESS CORRESPONDENCE TO ATTENTION OF
JOHN ABBOTT 304-558-2544

SUBJECT

RFQ COPY
 TYPE NAME/ADDRESS HERE

Danhill Construction Company
 PO Box 685
 Gauley Bridge, WV 25085

SHIP TO

HUTTONSVILLE CORRECTIONAL
 CENTER
 ATTENTION: KEN HOLBROOK
 ROUTE 250 SOUTH
 HUTTONSVILLE, WV
 26273 335-2291

DATE PRINTED	TERMS OF SALE	SHIP VIA	F.O.B	FREIGHT TERMS
03/13/2009				

BID OPENING DATE: 04/15/2009 BID OPENING TIME 01:30PM

LINE	QUANTITY	UOP	CAT NO.	ITEM NUMBER	UNIT PRICE	AMOUNT
NO. 1			04/06/09			
NO. 2			04/09/09			
NO. 3						
NO. 4						
NO. 5						

I UNDERSTAND THAT FAILURE TO CONFIRM THE RECEIPT OF THE ADDENDUM(S) MAY BE CAUSE FOR REJECTION OF THE BIDS.

VENDOR MUST CLEARLY UNDERSTAND THAT ANY VERBAL REPRESENTATION MADE OR ASSUMED TO BE MADE DURING ANY ORAL DISCUSSION HELD BETWEEN VENDOR'S REPRESENTATIVES AND ANY STATE PERSONNEL IS NOT BINDING. ONLY THE INFORMATION ISSUED IN WRITING AND ADDED TO THE SPECIFICATIONS BY AN OFFICIAL ADDENDUM IS BINDING.

..... Robert D. Hill SIGNATURE
 Danhill Const. Co. COMPANY
 4/21/09 DATE

REV. 11/96

CONTRACTORS LICENSE

WEST VIRGINIA STATE CODE 21-11-2 REQUIRES THAT ALL PERSONS DESIRING TO PERFORM CONTRACTING WORK IN THIS STATE MUST BE LICENSED. THE WEST VIRGINIA CONTRACTORS

SEE REVERSE SIDE FOR TERMS AND CONDITIONS

SIGNATURE Robert D. Hill	TELEPHONE 304-632-1600	DATE 4/21/09
TITLE President	FEIN 55-0648251	ADDRESS CHANGES TO BE NOTED ABOVE

WHEN RESPONDING TO RFQ, INSERT NAME AND ADDRESS IN SPACE ABOVE LABELED 'VENDOR'



State of West Virginia
 Department of Administration
 Purchasing Division
 2019 Washington Street East
 Post Office Box 50130
 Charleston, WV 25305-0130

Request for Quotation

RFQ NUMBER
COR61403

PAGE
7

ADDRESS CORRESPONDENCE TO ATTENTION OF
**JOHN ABBOTT
 304-558-2544**

VENDOR

RFQ COPY
 TYPE NAME/ADDRESS HERE

**Danhill Construction Company
 PO Box 685
 Gauley Bridge, WV 25085**

SHIP TO

**HUTTONSVILLE CORRECTIONAL
 CENTER
 ATTENTION: KEN HOLBROOK
 ROUTE 250 SOUTH
 HUTTONSVILLE, WV
 26273 335-2291**

DATE PRINTED	TERMS OF SALE	SHIP VIA	F.O.B.	FREIGHT TERMS
03/13/2009				

BID OPENING DATE: 04/15/2009 BID OPENING TIME 01:30PM

LINE	QUANTITY	UOP	CAT NO	ITEM NUMBER	UNIT PRICE	AMOUNT
<p>LICENSING BOARD IS EMPOWERED TO ISSUE THE CONTRACTORS LICENSE. APPLICATIONS FOR A CONTRACTORS LICENSE MAY BE MADE BY CONTACTING THE WEST VIRGINIA DIVISION OF LABOR CAPITOL COMPLEX, BUILDING 3, ROOM 319, CHARLESTON, WV 25305. TELEPHONE: (304) 558-7890.</p> <p>WEST VIRGINIA STATE CODE 21-11-11 REQUIRES ANY PROSPECTIVE BIDDER TO INCLUDE THE CONTRACTORS LICENSE NUMBER ON THEIR BID.</p> <p>BIDDER TO COMPLETE:</p> <p>CONTRACTORS NAME: <i>Danhill Construction Co.</i></p> <p>CONTRACTORS LICENSE NO.: <i>WV 001196</i></p> <p>THE SUCCESSFUL BIDDER WILL BE REQUIRED TO FURNISH A COPY OF THEIR CONTRACTORS LICENSE PRIOR TO ISSUANCE OF A PURCHASE ORDER/CONTRACT</p> <p style="text-align: center;">APPLICABLE LAW</p> <p>THE WEST VIRGINIA STATE CODE, PURCHASING DIVISION RULES AND REGULATIONS, AND THE INFORMATION PROVIDED IN THE "REQUEST FOR QUOTATION" ISSUED BY THE PURCHASING DIVISION IS THE SOLE AUTHORITY GOVERNING THIS PROCUREMENT.</p> <p>ANY INFORMATION PROVIDED IN SPECIFICATION MANUALS, OR ANY OTHER SOURCE, VERBAL OR WRITTEN, WHICH CONTRADICTS OR ALTERS THE INFORMATION PROVIDED FROM THE SOURCES AS DESCRIBED IN THE ABOVE PARAGRAPH IS VOID AND OF NO EFFECT.</p> <p>BANKRUPTCY: IN THE EVENT THE VENDOR/CONTRACTOR FILES FOR BANKRUPTCY PROTECTION, THIS CONTRACT IS AUTOMATI-</p>						

SEE REVERSE SIDE FOR TERMS AND CONDITIONS

SIGNATURE	TELEPHONE	DATE
	<i>304-632-1600</i>	<i>4/21/09</i>

TITLE	FEIN	ADDRESS CHANGES TO BE NOTED ABOVE
<i>President</i>	<i>55-0648251</i>	

WHEN RESPONDING TO RFQ, INSERT NAME AND ADDRESS IN SPACE ABOVE LABELED 'VENDOR'



State of West Virginia
 Department of Administration
 Purchasing Division
 2019 Washington Street East
 Post Office Box 50130
 Charleston, WV 25305-0130

Request for Quotation

RFQ NUMBER
COR61403

PAGE
8

ADDRESS CORRESPONDENCE TO ATTENTION OF
JOHN ABBOTT 304-558-2544

VENDOR

RFQ COPY
 TYPE NAME/ADDRESS HERE

Danhill Construction Company
 PO Box 685
 Gauley Bridge, WV 25085

SHIP TO

HUTTONSVILLE CORRECTIONAL
 CENTER
 ATTENTION: KEN HOLBROOK
 ROUTE 250 SOUTH
 HUTTONSVILLE, WV
 26273 335-2291

DATE PRINTED	TERMS OF SALE	SHIP VIA	F.O.B	FREIGHT TERMS
03/13/2009				

BID OPENING DATE: 04/15/2009	BID OPENING TIME: 01:30PM
------------------------------	---------------------------

LINE	QUANTITY	UOP	CAT NO	ITEM NUMBER	UNIT PRICE	AMOUNT
<p>CALLY NULL AND VOID, AND IS TERMINATED WITHOUT FURTHER ORDER.</p> <p>REV. 1/2005</p> <p style="text-align: center;">NOTICE</p> <p>A SIGNED BID MUST BE SUBMITTED TO:</p> <p style="text-align: center;">DEPARTMENT OF ADMINISTRATION PURCHASING DIVISION BUILDING 15 2019 WASHINGTON STREET, EAST CHARLESTON, WV 25305-0130</p> <p>THE BID SHOULD CONTAIN THIS INFORMATION ON THE FACE OF THE ENVELOPE OR THE BID MAY NOT BE CONSIDERED:</p> <p>SEALED BID</p> <p>BUYER: JOHN ABBOTT-----</p> <p>REQ. NO.: COR61403-----</p> <p>BID OPENING DATE: 4/15/2009-----</p> <p>BID OPENING TIME: 1:30 PM-----</p> <p>PLEASE PROVIDE A FAX NUMBER IN CASE IT IS NECESSARY TO CONTACT YOU REGARDING YOUR BID:</p> <p style="text-align: center;">----- 304-632-1501 -----</p> <p>PLEASE PRINT OR TYPE NAME OF PERSON TO CONTACT</p>						

SIGNATURE		TELEPHONE	DATE
		304-632-1600	4/21/09
TITLE	FEIN	ADDRESS CHANGES TO BE NOTED ABOVE	
President	55-0648251		

WHEN RESPONDING TO RFQ, INSERT NAME AND ADDRESS IN SPACE ABOVE LABELED 'VENDOR'



State of West Virginia
 Department of Administration
 Purchasing Division
 2019 Washington Street East
 Post Office Box 50130
 Charleston, WV 25305-0130

Request for Quotation

RFQ NUMBER
 COR61403

PAGE
 9

ADDRESS CORRESPONDENCE TO ATTENTION OF
 JOHN ABBOTT
 304-558-2544

VENDOR

RFQ COPY
 TYPE NAME/ADDRESS HERE

Danhill Construction Company
 PO Box 685
 Gauley Bridge, WV 25085

SHIP TO

HUTTONSVILLE CORRECTIONAL
 CENTER
 ATTENTION: KEN HOLBROOK
 ROUTE 250 SOUTH
 HUTTONSVILLE, WV
 26273 335-2291

DATE PRINTED	TERMS OF SALE	SHIP VIA	F.O.B.	FREIGHT TERMS
03/13/2009				

BID OPENING DATE: 04/15/2009 BID OPENING TIME: 01:30PM

LINE	QUANTITY	UOP	CAT NO	ITEM NUMBER	UNIT PRICE	AMOUNT
CONCERNING THIS QUOTE: <i>Robert D. Hill</i>						
***** THIS IS THE END OF RFQ COR61403 *****						TOTAL: \$ <u>85,800.00</u>

SEE REVERSE SIDE FOR TERMS AND CONDITIONS

SIGNATURE	TELEPHONE	DATE
<i>President</i>	304-632-1600	4/21/09
TITLE	FEIN	ADDRESS CHANGES TO BE NOTED ABOVE
	55-0648251	

WHEN RESPONDING TO RFQ, INSERT NAME AND ADDRESS IN SPACE ABOVE LABELED 'VENDOR'

Section 13 34 23.16

Fabricated Control Booths

PART 1 – GENERAL

- 1.1 Provide all labor, equipment and materials to furnish and install prefabricated portable anodized aluminum building(s) where shown on the drawings.
- 1.2 Related work Specified Elsewhere.
 - A. Electrical service supply and connection.
 - B. Site/Foundation work.
 - C. Unloading, placement, installation and anchoring.
 - D. Plumbing and piping (when required).
 - E. Specification Section 13 36 13.13 for Steel Tower.
- 1.3 Quality Assurance
 - A. Structures shall be the product of a manufacturer with a minimum of 30 years-documented experience in the design and fabrication of portable aluminum buildings.
 - B. The building should be similar to those manufactured by Porta-King Building Systems, 4133 Shoreline Drive, Earth City, MO 63045 or an approved equal.
 - C. Prefabricated buildings by manufacturers other than the one approved shall submit sufficient data to enable approval to be given. As a minimum: Design drawings and /or calculations, applicable certifications, catalog information, and color samples showing equal range of variety.
 - D. Electrical devices factory installed within the prefabricated building shall be UL listed. Factory installed wiring system shall bear UL Classification insignia certifying compliance with the National Electrical Code, 2005 and previous editions.
 - E. Adherence to applicable portions of state and local building codes is the responsibility of the owner. Building manufacturer shall not be responsible for permits, special engineering calculations or architectural type drawings unless otherwise notified in writing 3-weeks prior to release of bid document.
 - F. Design Loads: 50 PSF live load, 30 PSF wind load.
- 1.4 References
 - A. Upon request, the prefabricated building manufacturer shall provide the locations and owners of three (3) similar buildings that have been in service more than three (3) years. This will allow the architect/owner to inspect on site and obtain a statement from the owners on the quality of workmanship (fit and finish).
- 1.5 Submittals

- A. Upon award of order, manufacturer shall prepare and submit copies of shop drawings as required for each different building required for this project. Drawings shall include elevations, section, floor plan, electric schedule, service entrance locations, and anchor clip detail.
- B. Color charts illustrating available colors and patterns for specified finishes shall be submitted to owner for prompt selections.
- C. Warranty documents.

PART 2 – PRODUCTS

2.1 Product Construction

Building to be of aluminum construction, with natural satin anodized aluminum exterior surfaces. All anodized aluminum surfaces to carry a five-(5) year warranty from surface deterioration caused by oxidation. Building height to be as indicated on drawings. Model number to be similar to Duraluminum R-12064 as manufactured by Porta-King Building Systems, Earth City, MO on an 11'-0"x16'-0"x30'-0" high Tower as manufactured by PK Structures, Earth City, MO or equal.

- A. Structural members to be extruded aluminum angles, channels, and tee sections of structural alloy 6063T6, anodized 204R1, with ribbed pattern exterior surfaces.
- B. Fasteners used to manufacture and assemble buildings to be corrosion-proof type and to permit on-site replacement of damaged components. Welded fabrication is not acceptable.

2.2 Wall and Ceiling Panels

Wall panels to be 3/4" high-impact resistant and expansion resistant insulating OSB. Wall panels shall carry a five- (5) year warranty from swelling due to moisture absorption. Ceiling panel to be 3/4" thick, high impact resistant, moisture resistant, and expansion resistant insulating OSB with white vinyl permanently laminated to interior side, and plastic protective sheet laminated to upside. Ceiling panel to carry a five- (5) year warranty from swelling due to moisture absorption.

2.3 Finish

Clear anodized aluminum, diamond embossed sheet permanently laminated to exterior side. Interior to have vinyl walnut wood grain surface.

2.4 Floor Structure

Floor structure to be an integral part of the building with 1 1/2" solid waterproof insulating core fit tight against panels and fastened to bottom structural base frame.

- A. Finished floor shall be 3003 Treadbrite safety treadplate floor covering.

2.5 Doors

Doors to be of anodized aluminum, 1 3/4" tubular construction and half-glazed. Bottom portion to include panel finish to match interior and exterior building walls.

- A. Sliding door to restroom to be ceiling suspended in overhead track. Sliding doors shall incorporate a maximum-security laminated hook bolt deadlock with removable cylinders.
- B. Exterior swing door to swing outward and shall include lever entry lockset with key.

2.6 Windows and Glazing

Windows shall have anodized aluminum frames and inserts and to be industrial quality with active window panel to slide horizontally on stainless steel, ball-bearing rollers (plastic rollers are not acceptable). Windows to include inside positive locking device. Exterior window sill height to be

38" (inside sill height 34" from finished floor).

- A. Windows to be glazed with 3/16" clear tempered safety glass.

2.7 Counter

Furnish 22" deep, full-width walnut woodgrain plastic laminate counter, per plans, 32" a.f.f.

2.8 Electrical

Electrical service to include single phase, 100 amp capacity load center with main breaker, pre-wired in conduit, with one 230v circuit and four 115v circuit capacity – provide two spare circuits. All electric work shall be in compliance with the National Electrical Code. All electrical components shall bear the UL label.

- A. Furnish one 115v duplex outlet, and one 230v single outlet.
- B. Lights to be fluorescent type fixture with acrylic lens and wall switch (tubes to be furnished by others).
- C. Include one Thru-Wall HVAC unit 230V, 9,900C/11,600H BTU.
- D. Include one GFI Duplex outlet in Restroom.

2.9 Restroom

Provide integral restroom area complete with solid door, privacy lock and the following options (See drawing for layout):

- A. Ceiling mounted lighting and exhaust fan with wall switch.
- B. Standard water closet with tank.
- C. Standard wall mount lavatory with faucet.
- D. Point-of-use 2.5 gallon water heater.
- E. Standard accessory package (soap dispenser, paper towel dispenser, tissue holder and mirror).
- F. Provide weatherproof boot with PVC vent for connection to onsite plumbing (by others).
- G. Plumbing fixtures to be installed and plumbed on site, by others.

2.10 Exterior Roof

Exterior waterproof roofs include ribbed anodized fascia trim, matching structural with integral, self-contained gutters. Provide a 3" overhang. Roof ships installed.

PART 3 – EXECUTION

3.1 General

Install prefabricated buildings on a flat and level concrete pad in accordance with the manufacturer's placement drawings. Position units over the utility stub-ups; verify building is level and anchor (Anchors are supplied on site, by others. Comply with local codes).

Section 13 36 13.13

Steel Towers

Part 1 – General

1.1 Related Work

- A. The area where the tower is installed shall have a concrete slab or footings, troweled smooth and level.
- B. Foundations where the tower column placement occurs shall be capable of withstanding loading as prescribed by the tower manufacturer.
- C. See specification section 13 34 23.16 for accompanying cab specifications.

1.2 System Description

- A. This specification is intended to define requirements that apply to a 11'x16'x30' tower design for the WV Department of Corrections. The tower described will be a free standing, custom-engineered system, similar to that manufactured by PK Structures, Earth City, MO or equal and shall incorporate a 10'x5' Duraluminum cab similar to that manufactured by Porta-King Building Systems, Earth City, MO or equal.
- B. Tower must be easy to assemble and disassemble for ease of relocation with the use of hand tools.
- C. The deflection due to live load of structural members supporting floors shall not exceed 1/360 of the span.
- D. Wind Load, Seismic Load and Drift (lateral deflection) shall be limited to that allowable by the 2006 IBC.
- E. Design criteria for the structure shall comply with specific requirements for appropriate application live load and 30' top of deck height.

1.3 Reference/Code

- A. The codes and specifications listed below will be referenced in the design and fabrication of the tower.

2006 IBC
2000 29-CFR-1910 (OSHA)
ICBO No. 4627

AISC 360-5
AISC-SJ1
ASTM A500-GRADE B
ASTM A325
ASTM A36

ASTM A992
ASTM A490

B. Definitions:

The subsequent definitions give meaning to the terms listed above and others used in this specification.

IBC – International Building Code

UBC – Uniform Building Code

BOCA – Building Officials and Code Administrators

SBCCI – Southern Building Code Congress International Incorporated

OSHA – Occupational Safety and Health Administration

ICBO – International Conference of Building Officials

AISC – American Institute of Steel Construction

AISC-SJI – American Institute of Steel Construction – Steel Joist Institute

ASTM – American Standards and Testing Methods

AWS – American Welding Society

Dead Load – The allowance made in the load capacity of the tower to account for the weight of the tower structure.

Collateral Load – The additional dead loads other than the weight of the structure and decking materials..

Live Load – The maximum loading that the end user may safely place on the tower. Typically, live loads range from 50 PSF. to 100 PSF. Live load is a requirement specified by the end user.

Lateral Load – The force that acts horizontally on the structure causing the tower to sway. All structures shall be designed for some amount of lateral loading. The end user must specify location or seismic zone.

Lateral Deflection (Drift) – The amount that the tower will sway as a result of subjecting it to a lateral load.

Wind Load – Additional force that acts on the tower causing movement from uplift, down force and sway.

- C. The owner or end user must inform the tower manufacturer of any local codes, which may affect structural design.

1.4 Quality Assurance

- A. The system manufacturer shall be an established firm with a minimum of 10 years of documented experience in the design and fabrication of custom steel structural systems.
- B. The system shall be designed under the direct supervision of a professional engineer experienced in the design of towers in accordance with specifications and national model building codes.

- C. Installation contractor shall be a company experienced in installing tower systems.

1.5 Warranty

- A. The manufacturer will warrant the tower to be free from manufacturing defects for a period of one year.
- B. Warranty does not cover damage caused by conditions outside the control of the manufacturer.
- C. Modifications and/or variations to the system or its components will void and nullify warranties.

Part 2 – Products

2.0 General

- A. The tower shall be a custom engineered, freestanding structure. Designed to be in compliance with IBC 2006 code requirements. Items not specifically covered by this specification shall be governed by local codes.

2.1 Materials

A. **Beam-to-Column Connections:**

- 1) Beam to column and diagonal brace connections shall be capable of transferring shear forces and must be shown to have adequate capacity to insure structural stability without contribution of a fixed base plate connection.
- 2) Typical connection will consist of structural tee sections and gusseted seat angles, factory welded to columns. The connection brackets shall be positioned so that the shear center of the support beams coincides with that of the column. Acceptable connection designs shall be as shown in the AISC manual under “Suggested Details – Structural Tubing and Pipe – Beam to Column Connections. The vertical position of the structural tee section shall be positioned to provide a dependable and known moment capacity intermediate in degree between the rigidity of a Type 1 and the flexibility of a Type 2 connection as defined in the General Provisions of the AISC manual. This Type 3 “Semi-Rigid” connection along with “X” bracing will provide the required lateral support for towers in most locations.

- B. **Beam-to Beam Connections:** The beam reaction shall be transferred to the support by means of bolting the purlin to a structural angle that is factory welded to the main support girder. This single-angle Type 2 “Simple - Framing”

connection shall be welded in the factory in the form of an "L" to provide the necessary flexibility as described in the AISC manual.

- C. **Framing:** All framing shall be wide flange beam framing. Structural support beams shall be sized to satisfy the structural specifications. The chemistry will equal or exceed that of ASTM A992 or A572 requirements. The support beams shall be constructed from hot rolled, wide flange shapes with a minimum tensile yield strength of 50,000 psi. Beams framing into columns shall have a minimum flange width of 4". Cold-formed "C" channels are not acceptable.

- D. **Base Plate Connections:** Base plate shall be fully welded around the entire perimeter of the tower column. Base plates shall be centered on the column to facilitate a uniform transfer of axial loads and base shear to the foundation.

- E. **Columns:** Structural support columns shall be sized to satisfy the structural specifications. The chemistry will equal or exceed that of ASTM A500-Grade B requirements. The column section will be of square tube profile, since it has equal strength in both of the principle axis and can facilitate a high strength beam-to-column connection. The minimum diameter size of the square tube will be 5"x5".

- F. **Stair:** Stair assembly will have bar grate treads factory welded to stringers. Stair width shall not be less than 36". Treads will be designed with a completely closed riser closed design as defined by the 2006 IBC. Maximum rise per tread shall not exceed 7". Minimum run per tread shall not be less than 11". Stair shall maintain a minimum headroom clearance of 6'-8". Stringer and tread components shall have a chemistry, which equals or exceeds that of ASTM A36 requirements. The stair stringers will be a minimum of MC10x8.4. The treads will be 1/8" x 1" steel bar grate.

- G. **Guardrail:** Guardrail will be a 42" high, two-rail design and maintain a minimum clearance between rails. All railing shall have a minimum of a 4" high kickplate. Guardrail shall be assembled at the factory to be comprised as a welded, one-piece assembly. The guardrail shall fasten directly to the tower deck to achieve maximum strength and rigidity. The chemistry will equal or exceed that of ASTM A500-Grade B requirements. All rails will be 1 1/2" square tubing. Guardrails to be surfaced mounted to the deck surface without the intrusion of columns protruding through the deck surface. All guardrails shall be fastened to the deck surface using 3/8" x 2 1/2" bolts.

- H. **Stair Handrail:** Handrail on stairs will be a welded, one-piece assembly. Stair handrails will have end returns that continue horizontally for 12" past the rear of the top tread. The same is true at the bottom except the distance is measured from the front nosing and increased to 12" plus the depth of one tread. Handrail will be provided at both sides of the stair. Handrail shall fasten to the outside of the stringers to facilitate a plumb rail without the use of any shims. Handrail shall be free of any sharp edges or protrusions. Ends of handrail shall be designed to avoid hooking on clothing and therefore avoid the possibility of that encouraging an accident. The 2006 IBC requires both guardrails and handrails on stairs. This will be provided as a standard.
- I. **Landing:** Depth of landing will not be less than the width of the stairs. All landings will cantilever off of the main structure of the tower.
- J. **Finish:** The tower will be galvanized for exterior use. Painting presents unnecessary maintenance issues. If painting is required the surface of the steel will be cleaned of rust and dirt that will impede the adhesion of the paint. The mezzanine will receive one coat of Sherwin Williams Polane 700T™, one component, polyurethane acrylic enamel. All components shall be painted gray. Painted structures will rust.
- 1) **Decking:** Standard decking shall be Bar Grating with a minimum of 1" x 1/8" bearing bars, type W/B 3. All bar grate manufacturing capacity ratings must be corrected to satisfy L/360 deflection criteria. Attachment to the structure shall be through a bar grate manufacturers pre welded lug or saddle clip utilizing a tek 5 screw.

2.2 Fabrication

- A. Fabrication of materials will comply with dimensions, profiles and gauges shown on the approval drawings.
- B. Manufacturing to be performed by a U.S. company.
- C. System design to be performed by a degreed structural engineer. Design performed by technicians through the use of charts is unacceptable.
- D. All design and analysis must be done under the direct supervision of a Professional Engineer. Professional Engineering seals and calculations can be provided for any state, but must be specified during the bid process.
- E. Any exceptions taken to this specification must be submitted in writing with the proposal package. In addition to listing the exceptions, it shall be explained how

deviating from this specification results in a superior tower design for the end user.

Part 3-Execution

3.1 Inspection

- A. Inspect working areas to insure that job site is cleared and free of all debris and obstacles so installer shall have adequate access to the work area. Owner shall advise the Installation Company of any known obstacles, which may interfere with the installation of tower components.

3.2 Preparation

- A. The tower contractor's technician shall make an inspection of the job site prior to preparation of approval drawings.

3.3 Installation

- A. The structural capacity of the foundation is to be determined by others using sound engineering practices. The true and level condition as well as the capacity of the floor surface is the responsibility of others.
- B. Installation of the tower and accessories shall be in accordance with the specifications and instructions contained in the installation manual and drawings.



Tower to be similar in design



State of West Virginia
 Department of Administration
 Purchasing Division
 2019 Washington Street East
 Post Office Box 50130
 Charleston, WV 25305-0130

Request for Quotation

RFO NUMBER
COR61403

PAGE
1

ADDRESS CORRESPONDENCE TO ATTENTION OF
JOHN ABBOTT 304-558-2544

VENDOR

*709053330 304-632-1558
 DANHILL CONSTRUCTION COMPANY
 PO BOX 685
 GAULEY BRIDGE WV 25085

SHIP TO

HUTTONSVILLE CORRECTIONAL
 CENTER
 ATTENTION: KEN HOLBROOK
 ROUTE 250 SOUTH
 HUTTONSVILLE, WV
 26273 335-2291

DATE PRINTED	TERMS OF SALE	SHIP VIA	F.O.B.	FREIGHT TERMS
04/06/2009				

BID OPENING DATE: 04/15/2009 BID OPENING TIME 01:30PM

LINE	QUANTITY	UOP	CAT NO	ITEM NUMBER	UNIT PRICE	AMOUNT
ADDENDUM #01						
THIS ADDENDUM IS ISSUED TO CLARIFY, MODIFY, AND ADD TO THE REQUIREMENTS OF THE ORIGINAL SPECIFICATIONS, PER THE ATTACHED DOCUMENTATION.						
0001	1	LS		968-20		\$85,800
				GUARD BUILDING AND TOWER		
***** THIS IS THE END OF RFQ COR61403 ***** TOTAL:						\$85,800.00

SEE REVERSE SIDE FOR TERMS AND CONDITIONS			
SIGNATURE	TELEPHONE	DATE	
<i>Robert D. Hill</i>	632-1600	4-21-09	
TITLE	FEIN	ADDRESS CHANGES TO BE NOTED ABOVE	
<i>Pres</i>	55-0648251		

WHEN RESPONDING TO RFQ, INSERT NAME AND ADDRESS IN SPACE ABOVE LABELED 'VENDOR'

MEMORANDUM

TO: John Abbott, Buyer
West Virginia Division of Purchasing

FROM: Bill Wimer, Construction Manager
West Virginia Division of Corrections

DATE: April 6, 2009

RE: COR61403 Addendum #1

The following information consists of Addendum#1 to the Huttonsville Correctional Center Guard Tower Project.

- Item #1 Contractor to cad weld ground cable to column.
- Item #2 Contractor to epoxy grout base plates.
- Item #3 Contractor may use owner's Porta-John.
- Item #4 Owner to supply electric to contractor.
- Item #5 Contractor to submit drawings with bid.
- Item #6 Contractor must comply with all security procedures.
- Item #7 Contractor to supply all additional concrete foundations required for the tower i.e. bottom of stairs and stair platform supports.
- Item #7 Foundation drawings attached.

HUTTONSVILLE
GUARD TOWER FDN.

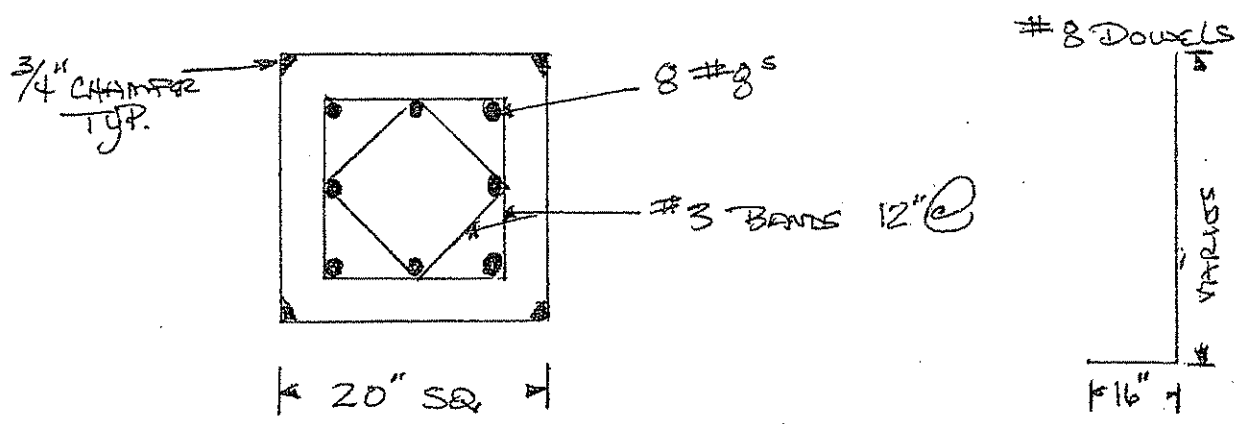
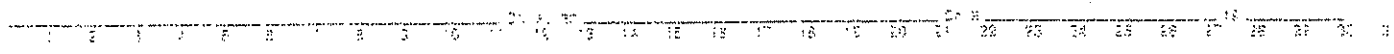

4500 PSI CONCRETE

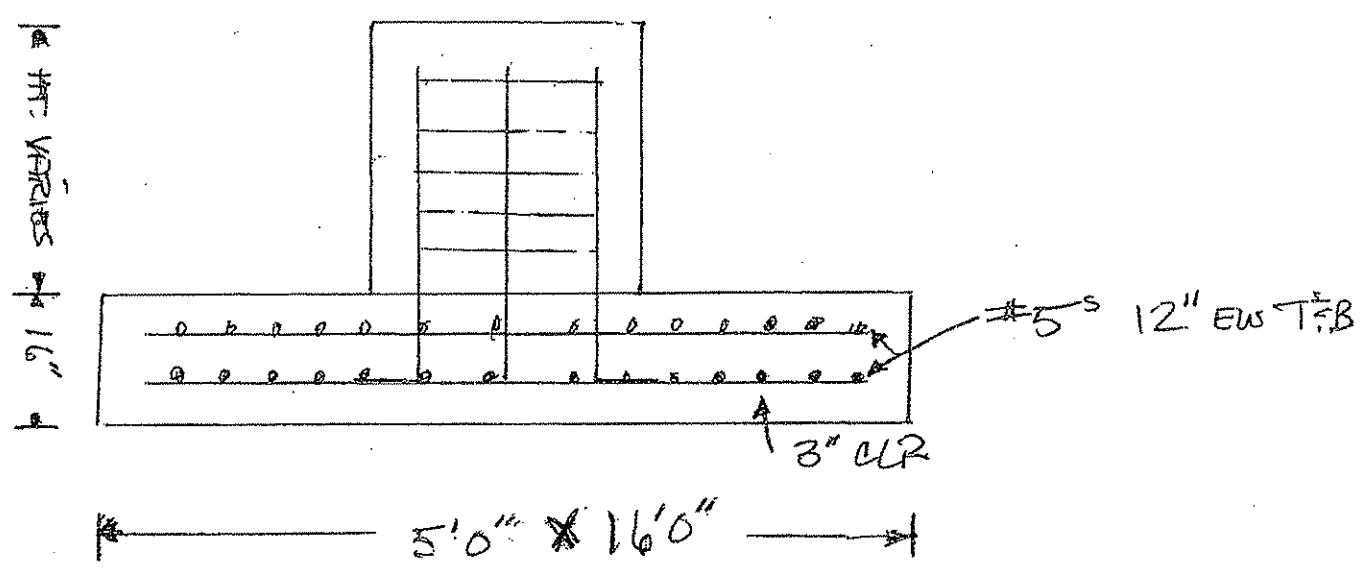

Grounding
N.T.S.

10 FT Ground Rod in Bottom of Fdn.
4 no copper ground cable to extend 2 FT ABOVE PIER



PROJECT: HUTTONSVILLE
 GUARD TOWER FDN'S.

DATE: _____

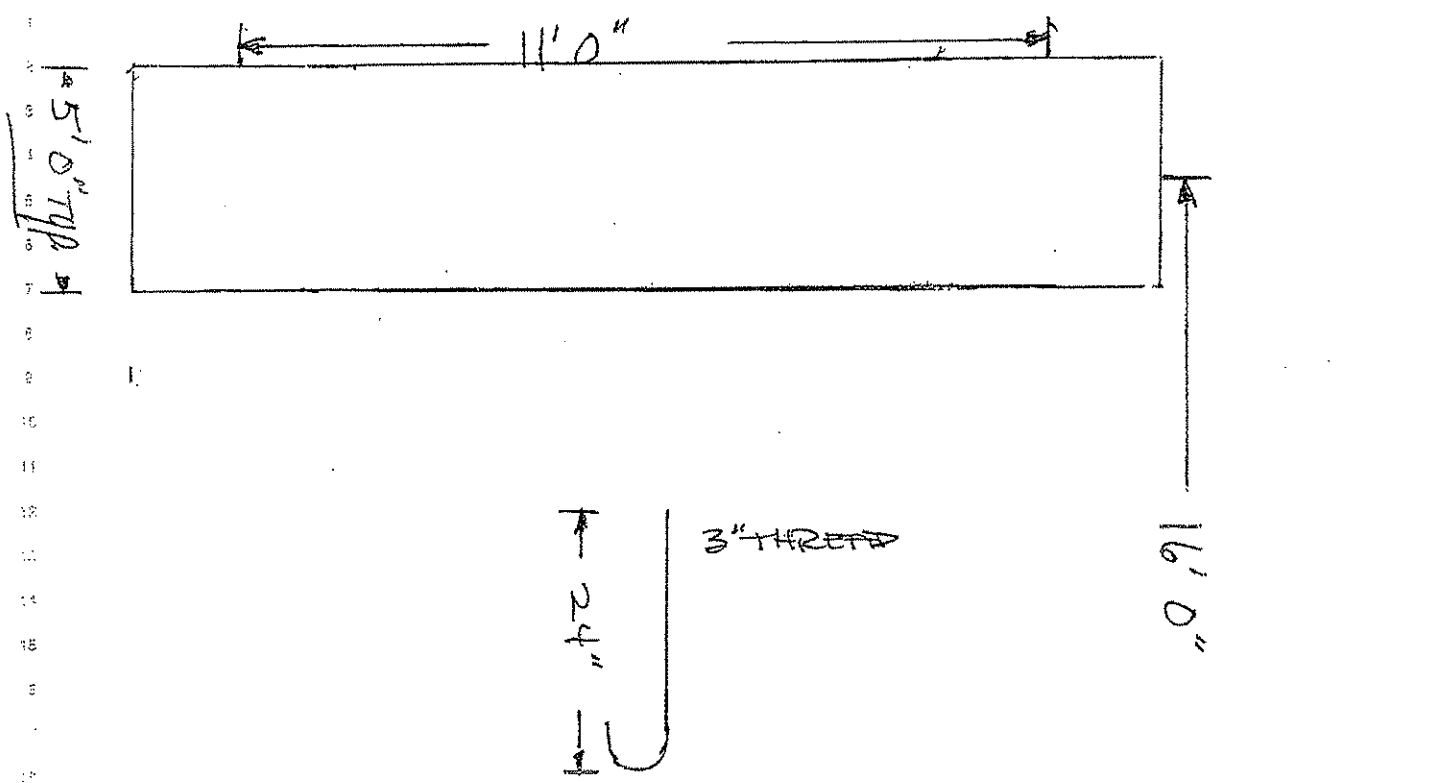

NOTE: $\frac{3}{4}$ " ϕ ANCHOR BOLT - 4 PER PER GALVANIZED
 BOLT PATTERN AS LATER DATE

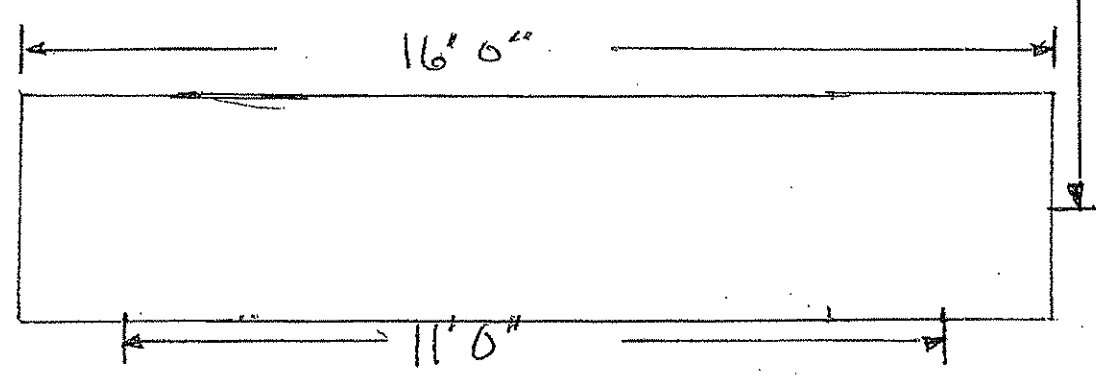

N.T.S.





State of West Virginia
 Department of Administration
 Purchasing Division
 2019 Washington Street East
 Post Office Box 50130
 Charleston, WV 25305-0130

Request for Quotation

RFQ NUMBER
COR61403

PAGE
1

ADDRESS CORRESPONDENCE TO ATTENTION OF:
JOHN ABBOTT
304-558-2544

VENDOR
 *709053330 304-632-1558
DANHILL CONSTRUCTION COMPANY
PO BOX 685

GAULEY BRIDGE WV 25085

SHIP TO
HUTTONSVILLE CORRECTIONAL
CENTER
ATTENTION: KEN HOLBROOK
ROUTE 250 SOUTH
HUTTONSVILLE, WV
26273 335-2291

DATE PRINTED:	TERMS OF SALE	SHIP VIA	F.O.B.	FREIGHT TERMS
04/09/2009				

BID OPENING DATE: **04/21/2009** BID OPENING TIME **01:30PM**

LINE	QUANTITY	UOP	CAT. NO	ITEM NUMBER	UNIT PRICE	AMOUNT
ADDENDUM #02						
THIS ADDENDUM IS ISSUED TO CHANGE THE REQUIREMENT STATED ON ADDENDUM #01; WHEREAS ITEM# 5 STATES: "CONTRACTOR TO SUBMIT DRAWINGS WITH BID." - THIS SHALL BE CHANGED TO: "CONTRACTOR SHOULD SUBMIT DRAWINGS WITH BID; CONTRACTOR SHALL SUBMIT DRAWINGS WITHIN 5 WORKING DAYS UPON REQUEST."						
THE BID OPENING DATE HAS BEEN CHANGED FROM 4/15/2009 TO 4/21/2009; 1:30 PM						
REVISED BID OPENING DATE: 4/21/2009; 1:30 PM						
0001	1	LS		968-20		<u>\$85,800.00</u>
GUARD BUILDING AND TOWER						
***** THIS IS THE END OF RFQ COR61403 ***** TOTAL:						<u>\$85,800.00</u>

SEE REVERSE SIDE FOR TERMS AND CONDITIONS

SIGNATURE <i>Robert D. Hill</i>	TELEPHONE 632-1600	DATE 4-21-09
TITLE <i>Pres</i>	FEIN 55.0648251	ADDRESS CHANGES TO BE NOTED ABOVE

WHEN RESPONDING TO RFQ, INSERT NAME AND ADDRESS IN SPACE ABOVE LABELED 'VENDOR'

BID BOND

KNOW ALL MEN BY THESE PRESENTS, That we, the undersigned, Danhill Construction Company
of Gauley Bridge, West Virginia, as Principal, and Colonial Surety Co.
of Montvale, New Jersey, a corporation organized and existing under the laws of the State of NJ
with its principal office in the City of Montvale, as Surety, are held and firmly bound unto the State
of West Virginia, as Obligee, in the penal sum of Four Thousand Nine Hundred Dollars (\$ 4,900.00) for the
payment of which, well and truly to be made, we jointly and severally bind ourselves, our heirs, administrators, executors, successors
and assigns.

The Condition of the above obligation is such that whereas the Principal has submitted to the Purchasing Section of the
Department of Administration a certain bid or proposal, attached hereto and made a part hereof, to enter into a contract in writing for
Purchase and install pre-fab guard tower.

NOW THEREFORE,

(a) If said bid shall be rejected, or
(b) If said bid shall be accepted and the Principal shall enter into a contract in accordance with the bid or proposal attached
hereto and shall furnish any other bonds and insurance required by the bid or proposal, and shall in all other respects perform the
agreement created by the acceptance of said bid, then this obligation shall be null and void, otherwise this obligation shall remain in full
force and effect. It is expressly understood and agreed that the liability of the Surety for any and all claims hereunder shall, in no event,
exceed the penal amount of this obligation as herein stated.

The Surety, for the value received, hereby stipulates and agrees that the obligations of said Surety and its bond shall be in no
way impaired or affected by any extension of the time within which the Obligee may accept such bid, and said Surety does hereby
waive notice of any such extension.

IN WITNESS WHEREOF, Principal and Surety have hereunto set their hands and seals, and such of them as are corporations
have caused their corporate seals to be affixed hereunto and these presents to be signed by their proper officers, this
21st day of April, 20 09.

Principal Corporate Seal

Danhill Construction Company
(Name of Principal)
By Robert D. Hill *Robert D. Hill*
(Must be President or
Vice President)
President
(Title)

Surety Corporate Seal

Colonial Surety company
(Name of Surety)
Roberta Bird *Roberta Bird*
Attorney-in-Fact

IMPORTANT – Surety executing bonds must be licensed in West Virginia to transact surety insurance. Raised corporate seals must be affixed, a power of attorney must be attached.

Colonial Surety Company

Administrative Office
50 Chestnut Ridge Road
Montvale, NJ 07645

CONSENT OF SURETY

Huttonsville Correctional Center
Route 250. South
Huttonsville, WV 26273

RE: Purchase and install pre-fab Guard Tower

COLONIAL SURETY COMPANY organized and existing under the laws of the Commonwealth of Pennsylvania and duly qualified to transact business in the State of WV hereby agrees that

Danhill Construction Company

Glen Ferris, WV

has submitted a proposal on the captioned project. We hereby agree that in the event an award is made to

Danhill Construction Company

Glen Ferris, WV

that we will provide the required performance, payment and/or maintenance bonds.

Signed and sealed this 21st day of April 2009.

COLONIAL SURETY COMPANY

BY: Roberta Bird
Roberta Bird (Attorney-in-Fact)

COLONIAL SURETY COMPANY

Duncannon, Pennsylvania
Administrative Office: 50 Chestnut Ridge Road, Montvale, New Jersey 07645

GENERAL POWER OF ATTORNEY

Know all Men by These Presents, That COLONIAL SURETY COMPANY, a corporation duly organized and existing under the laws of the Commonwealth of Pennsylvania and having an administrative office in Montvale, Bergen County, NJ does by these presents make, constitute and appoint

Roberta Bird
Glen Ferris WV its true and lawful Attorney(s)-in-Fact, with full power and authority hereby conferred in its name, place and stead, to execute, acknowledge and deliver.

Any and All Bonds

and to bind the Company thereby as fully and to the same extent as if such bonds were signed by the President, sealed with the corporate seal of the Company and duly attested by its Secretary, hereby ratifying and confirming all that the said Attorney(s)-in-Fact may do in the premises. Said appointment is made under and by authority of the following resolution adopted by the Board of Directors of the Colonial Surety Company at a meeting held on the 25th day of July, 1950.

Be it Resolved, that the President, any Vice-President, any Secretary or any Assistant Secretary shall be and is hereby vested with full power and authority to appoint any one or more suitable persons as Attorney(s)-in-Fact to represent and act for and on behalf of the Company subject to the following provisions:

Section 1. Attorney-in-Fact. Attorney-in-Fact may be given full power and authority for and in the name of and on behalf of the Company, to execute, acknowledge and deliver, any and all bonds, recognizances, contracts, agreements of indemnity and other conditional or obligatory undertakings and any and all notices and documents canceling or terminating the Company's liability thereunder, and any such instruments so executed by any such Attorney-in-Fact shall be binding upon the Company as if signed by the President and sealed and attested by the Corporate Secretary.

In Witness Whereof, Colonial Surety Company has caused these presents to be signed by its President and its corporate seal to be hereto affixed the 8th day of September, A.D., 2006.

State of New Jersey
County of Bergen } SS.:



COLONIAL SURETY COMPANY

By Wayne Nunziata, President

On this 8th day of September, in the year 2006, before me Theresa Simmons, a notary public, personally appeared Wayne Nunziata, personally known to me to be the person who executed the within instrument as President, on behalf of the corporation therein named and acknowledged to me that the corporation executed it.



THERESA SIMMONS
A Notary Public of New Jersey
My Commission Expires September 2, 2010

Theresa Simmons
Notary Public

I, the undersigned Secretary of Colonial Surety Company, hereby certify that the above and foregoing is a full, true and correct copy of the Original Power of Attorney issued by said Company, and do hereby further certify that the said Power of Attorney is still in force and effect.

And I do hereby further certify that the Certification of this Power of Attorney is signed and sealed by facsimile under and by the authority of the following resolution adopted by the Board of Directors of the Colonial Surety Company at a meeting duly called and held on the 30th of January 1968, and that said resolution has not been amended or repealed:

RESOLVED, that the signature of the Secretary or any Assistant Secretary of this Corporation, and the seal of Corporation, may be affixed or printed by facsimile to any certificate to a Power of Attorney of this Corporation, and that such printed facsimile signature and seal shall be valid and binding upon this Corporation.

GIVEN under my hand and the seal of said Company, at Montvale, New Jersey this 21st day of April, 2009.

For verification of the authenticity of this Power of Attorney you may call (201) 573-8788 and ask for the Power of Attorney clerk. Please refer to the above named individual(s) and details of the bond to which the power is attached.

Frederick S. Gallo, Secretary

State of West Virginia

County of Fayette

AND NOW, this 21st day of April, in the calendar year of 2009, before me, a duly appointed and commissioned notary public, came the identified subscriber to the within instrument or instruments, and/or the demonstrated attorney-in-fact for said signatory and subscriber on said instrument or instruments, **Roberta Bird, attorney-in-fact of Colonial Surety Company**, an insurance company duly organized and existing under the laws of the Commonwealth of Pennsylvania and which is authorized to conduct business in this State, and that as such being authorized to do so, acknowledged that the within instrument or instruments were executed as the authorized act of his disclosed principal for the purposes therein contained, and declared to be a person executing said instrument or instruments as attorney-in-fact and with full capacity and competency, at the request of and on behalf of Colonial Surety Company therein named and acknowledged to me that the aforesaid Colonial Surety Company had authorized the execution by the aforesaid attorney-in-fact of said instrument or instruments with the intent to be legally bound as required by common and statutory law.

IN WITNESS WHEREOF, I hereunto set my hand and official seal.

A Notary Public of West Virginia
My Commission Expires on 3/28/2015

Notary Public in and for the

County of Fayette
State of West Virginia

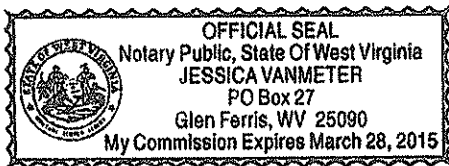

Jessica VanMeter
NOTARY PUBLIC

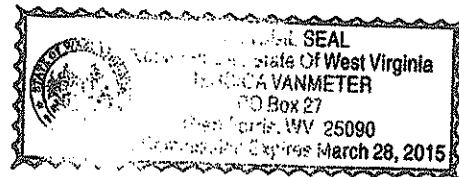

COLONIAL SURETY COMPANY
Duncannon, Pennsylvania
- Inc 1930 -

FINANCIAL STATEMENT—DECEMBER 31, 2007

ASSETS		LIABILITIES & SURPLUS	
*Stocks and Bonds	\$ 22,333,566	Reserve for Unearned Premiums	\$5,524,430
Cash in Office & Banks	2,802,343	Claim Reserves	9,472,120
Accrued Interest & Dividends	271,910	Other Liabilities	1,067,768
Premiums & Agents Balances Receivable	636,235	Collateral Held	462,719
Other Assets	875,886	Capital Stock	3,000,000
.....		Surplus	7,392,903
Total Admitted Assets	26,919,940	Total Liabilities & Surplus	26,919,940

*Bonds and stocks are valued on basis approved by National Association of Insurance Commissioners.

STATE OF NEW JERSEY
COUNTY OF BERGEN **ss.:**

I, Wayne Nunziata, President of COLONIAL SURETY COMPANY, do hereby certify that the foregoing is a full, true and correct copy of the Financial Statement of said Company, as of December 31, 2007.

IN WITNESS WHEREOF, I have signed this statement at Montvale, New Jersey, this 15th day of February, 2008.



Wayne Nunziata

Wayne Nunziata President

Theresa Simmons

Theresa Simmons Notary Public

Theresa Simmons
A Notary Public of New Jersey
My Commission Expires September 2, 2010

CONTRACTOR LICENSE

Authorized by the

West Virginia Contractor Licensing Board

Number: WV001196

Classification:

ELECTRICAL
GENERAL BUILDING
HEATING, VENTILATING & COOLING
MULTIFAMILY
PIPING
PLUMBING
RESIDENTIAL

DANHILL CONSTRUCTION COMPANY
PO BOX 685
GAULEY BRIDGE, WV 25085-0685

Date Issued

AUGUST 06, 2008

Expiration Date

AUGUST 06, 2009

Authorized Company Signature

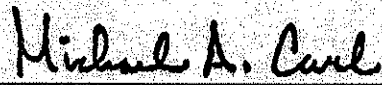
Chair, West Virginia Contractor
Licensing Board



**WEST VIRGINIA
CONTRACTOR
LICENSING
BOARD**

This license, or a copy thereof, must be posted in a conspicuous place at every construction site where work is being performed. This license number must appear in all advertisements, on all bid submissions and on all fully executed and binding contracts. This license cannot be assigned or transferred by licensee. Issued under provisions of West Virginia Code, Chapter 21, Article 11.

ACORD CERTIFICATE OF LIABILITY INSURANCE

DATE (MM/DD/YYYY)
5/7/2008

PRODUCER (304)720-2000 FAX: (304)720-2002
Mountain State Insurance Agency
1206 Kanawha Blvd. E.

THIS CERTIFICATE IS ISSUED AS A MATTER OF INFORMATION ONLY AND CONFERS NO RIGHTS UPON THE CERTIFICATE HOLDER. THIS CERTIFICATE DOES NOT AMEND, EXTEND OR ALTER THE COVERAGE AFFORDED BY THE POLICIES BELOW.

Charleston WV 25301

INSURERS AFFORDING COVERAGE

NAIC #

INSURED

INSURER A: Westfield

24112

DanHill Construction Company (Inc.)
Box 685

INSURER B:

INSURER C:

INSURER D:

INSURER E:

Gauley Bridge WV 25085

COVERAGES

THE POLICIES OF INSURANCE LISTED BELOW HAVE BEEN ISSUED TO THE INSURED NAMED ABOVE FOR THE POLICY PERIOD INDICATED. NOTWITHSTANDING ANY REQUIREMENT, TERM OR CONDITION OF ANY CONTRACT OR OTHER DOCUMENT WITH RESPECT TO WHICH THIS CERTIFICATE MAY BE ISSUED OR MAY PERTAIN, THE INSURANCE AFFORDED BY THE POLICIES DESCRIBED HEREIN IS SUBJECT TO ALL THE TERMS, EXCLUSIONS AND CONDITIONS OF SUCH POLICIES. AGGREGATE LIMITS SHOWN MAY HAVE BEEN REDUCED BY PAID CLAIMS.

INSR ADD'L LTR	INSRD	TYPE OF INSURANCE	POLICY NUMBER	POLICY EFFECTIVE DATE (MM/DD/YY)	POLICY EXPIRATION DATE (MM/DD/YY)	LIMITS		
A		GENERAL LIABILITY	CWP3808332	5/24/2008	5/24/2009	EACH OCCURRENCE \$ 1,000,000		
		<input checked="" type="checkbox"/> COMMERCIAL GENERAL LIABILITY				DAMAGE TO RENTED PREMISES (Ea occurrence) \$ 300,000		
		<input type="checkbox"/> CLAIMS MADE <input checked="" type="checkbox"/> OCCUR				MED EXP (Any one person) \$ 10,000		
						PERSONAL & ADV INJURY \$ 1,000,000		
						GENERAL AGGREGATE \$ 2,000,000		
						PRODUCTS - COMP/OP AGG \$ 2,000,000		
GEN'L AGGREGATE LIMIT APPLIES PER:								
<input checked="" type="checkbox"/>		POLICY	<input type="checkbox"/>		PRO-JECT	<input type="checkbox"/>		LOC
A		AUTOMOBILE LIABILITY	CWP3808332	5/24/2008	5/24/2009	COMBINED SINGLE LIMIT (Ea accident) \$ 1,000,000		
		<input checked="" type="checkbox"/> ANY AUTO				BODILY INJURY (Per person) \$		
		<input type="checkbox"/> ALL OWNED AUTOS				BODILY INJURY (Per accident) \$		
		<input type="checkbox"/> SCHEDULED AUTOS				PROPERTY DAMAGE (Per accident) \$		
<input type="checkbox"/> HIRED AUTOS								
<input type="checkbox"/> NON-OWNED AUTOS								
		GARAGE LIABILITY				AUTO ONLY - EA ACCIDENT \$		
		<input type="checkbox"/> ANY AUTO				OTHER THAN EA ACC \$		
						AUTO ONLY: AGG \$		
A		EXCESS/UMBRELLA LIABILITY	CWP3808332	5/24/2008	5/24/2009	EACH OCCURRENCE \$ 5,000,000		
		<input type="checkbox"/> OCCUR <input type="checkbox"/> CLAIMS MADE				AGGREGATE \$ 5,000,000		
		<input type="checkbox"/> DEDUCTIBLE				\$		
		<input checked="" type="checkbox"/> RETENTION \$ 0				\$		
A		WORKERS COMPENSATION AND EMPLOYERS' LIABILITY	CWP3808332	5/24/2008	5/24/2009	WC STATU-TORY LIMITS \$		
		ANY PROPRIETOR/PARTNER/EXECUTIVE OFFICER/MEMBER EXCLUDED?				OTHER \$		
		If yes, describe under SPECIAL PROVISIONS below				E.L. EACH ACCIDENT \$ 1,000,000		
						E.L. DISEASE - EA EMPLOYEE \$ 1,000,000		
		OTHER				E.L. DISEASE - POLICY LIMIT \$ 1,000,000		

DESCRIPTION OF OPERATIONS/LOCATIONS/VEHICLES/EXCLUSIONS ADDED BY ENDORSEMENT/SPECIAL PROVISIONS

This certificate is only for proof of insurance. This certificate does not confer on or extend insurance coverage to any recipient. This certificate does not amend any insurance coverages. All insurance coverages are subject of the policy terms and conditions.

CERTIFICATE HOLDER

For Insurance Purposes Only

CANCELLATION

SHOULD ANY OF THE ABOVE DESCRIBED POLICIES BE CANCELLED BEFORE THE EXPIRATION DATE THEREOF, THE ISSUING INSURER WILL ENDEAVOR TO MAIL 30 DAYS WRITTEN NOTICE TO THE CERTIFICATE HOLDER NAMED TO THE LEFT, BUT FAILURE TO DO SO SHALL IMPOSE NO OBLIGATION OR LIABILITY OF ANY KIND UPON THE INSURER, ITS AGENTS OR REPRESENTATIVES.

AUTHORIZED REPRESENTATIVE
Darlene Payne/DARLEN





PRODUCER:

BrickStreet Mutual Insurance Company
400 Quarrier Street
Charleston, WV 25301

CERTIFICATE HOLDER:

DANHILL CONSTRUCTION COMPANY
PO BOX 685
GAULEY BRIDGE, WEST VIRGINIA 25085-0685

INSURED:

DANHILL CONSTRUCTION COMPANY
PO BOX 685
GAULEY BRIDGE, WEST VIRGINIA 25085-0685

CERTIFICATE OF INSURANCE

The policy of insurance listed below has been issued to the insured named above for the policy period and coverage indicated. This certificate is issued as a matter of information only and confers no rights upon the certificate holder. This certificate does not amend, extend or alter the coverage afforded by the policy below. Coverage is contingent on the insured's compliance with policy conditions and premium payment.

If the policy is canceled before the expiration date, BrickStreet Mutual Insurance Company will endeavor to mail a written notice to the certificate holder within 30 days of cancelation. Failure to mail the notice shall impose no obligation or liability of any kind upon BrickStreet Mutual Insurance Company.

POLICY NUMBER: WC10009090-05

DATE CERTIFICATE ISSUED: 09/02/2008

POLICY EFFECTIVE DATE: 08/28/2008

EXPIRATION DATE: 08/28/2009

WORKERS COMPENSATION AND EMPLOYERS LIABILITY

LIMITS / COVERAGE

WORKERS COMPENSATION - STATUTORY LIMITS

EMPLOYERS LIABILITY LIMITS:

BODILY INJURY BY ACCIDENT:	\$ 100,000.00	EACH ACCIDENT
BODILY INJURY BY DISEASE:	\$ 500,000.00	POLICY LIMIT
BODILY INJURY BY DISEASE:	\$ 100,000.00	EACH EMPLOYEE

**WV BROAD FORM EMPLOYERS LIABILITY ENDORSEMENT -
COVERAGE FOR WV CODE 23-4-2(d)(2)(ii)**

**FEDERAL COAL MINE HEALTH AND SAFETY ACT COVERAGE ENDORSEMENT -
COVERAGE FOR WV CODE 23-4b-1 - FEDERAL BLACK LUNG COVERAGE**

SPECIAL PROVISIONS IF ANY:



State of West Virginia
DRUG FREE WORKPLACE CONFORMANCE AFFIDAVIT
West Virginia Code §21-1D-5

STATE OF RDH Fayette West Virginia

COUNTY OF Fayette, TO-WIT:

I, Robert D. Hill, after being first duly sworn, depose and state as follows:

- 1. I am an employee of Danhill Construction Co.; and,
(Company Name)
- 2. I do hereby attest that Danhill Construction Co.
(Company Name)

maintains a valid written drug free workplace policy and that such policy is in compliance with **West Virginia Code §21-1D-5**.

The above statements are sworn to under the penalty of perjury.

Danhill Construction Co.
(Company Name)

By: Robert D. Hill

Title: President

Date: 4/21/2009

Taken, subscribed and sworn to before me this 21 day of April 2009.

By Commission expires 3/28/2015

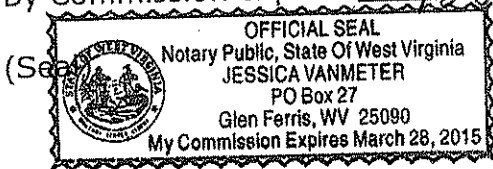

Jessica Vanmeter
(Notary Public)

THIS AFFIDAVIT MUST BE SUBMITTED WITH THE BID IN ORDER TO COMPLY WITH WV CODE PROVISIONS. FAILURE TO INCLUDE THE AFFIDAVIT WITH THE BID SHALL RESULT IN DISQUALIFICATION OF THE BID.

STATE OF WEST VIRGINIA
Purchasing Division**PURCHASING AFFIDAVIT****VENDOR OWING A DEBT TO THE STATE:**

West Virginia Code §5A-3-10a provides that: No contract or renewal of any contract may be awarded by the state or any of its political subdivisions to any vendor or prospective vendor when the vendor or prospective vendor or a related party to the vendor or prospective vendor is a debtor and the debt owed is an amount greater than one thousand dollars in the aggregate.

PUBLIC IMPROVEMENT CONTRACTS & DRUG-FREE WORKPLACE ACT:

If this is a solicitation for a public improvement construction contract, the vendor, by its signature below, affirms that it has a written plan for a drug-free workplace policy in compliance with Article 1D, Chapter 21 of the *West Virginia Code*. The vendor **must** make said affirmation with its bid submission. Further, public improvement construction contract may not be awarded to a vendor who does not have a written plan for a drug-free workplace policy in compliance with Article 1D, Chapter 21 of the *West Virginia Code* and who has not submitted that plan to the appropriate contracting authority in timely fashion. For a vendor who is a subcontractor, compliance with Section 5, Article 1D, Chapter 21 of the *West Virginia Code* may take place before their work on the public improvement is begun.

ANTITRUST:

In submitting a bid to any agency for the state of West Virginia, the bidder offers and agrees that if the bid is accepted the bidder will convey, sell, assign or transfer to the state of West Virginia all rights, title and interest in and to all causes of action it may now or hereafter acquire under the antitrust laws of the United States and the state of West Virginia for price fixing and/or unreasonable restraints of trade relating to the particular commodities or services purchased or acquired by the state of West Virginia. Such assignment shall be made and become effective at the time the purchasing agency tenders the initial payment to the bidder.

I certify that this bid is made without prior understanding, agreement, or connection with any corporation, firm, limited liability company, partnership or person or entity submitting a bid for the same materials, supplies, equipment or services and is in all respects fair and without collusion or fraud. I further certify that I am authorized to sign the certification on behalf of the bidder or this bid.

LICENSING:

Vendors must be licensed and in good standing in accordance with any and all state and local laws and requirements by any state or local agency of West Virginia, including, but not limited to, the West Virginia Secretary of State's Office, the West Virginia Tax Department, West Virginia Insurance Commission, or any other state agencies or political subdivision. Furthermore, the vendor must provide all necessary releases to obtain information to enable the Director or spending unit to verify that the vendor is licensed and in good standing with the above entities.

CONFIDENTIALITY:

The vendor agrees that he or she will not disclose to anyone, directly or indirectly, any such personally identifiable information or other confidential information gained from the agency, unless the individual who is the subject of the information consents to the disclosure in writing or the disclosure is made pursuant to the agency's policies, procedures and rules. Vendor further agrees to comply with the Confidentiality Policies and Information Security Accountability Requirements, set forth in <http://www.state.wv.us/admin/purchase/privacy/noticeConfidentiality.pdf>.

Under penalty of law for false swearing (*West Virginia Code* §61-5-3), it is hereby certified that the vendor affirms and acknowledges the information in this affidavit and is in compliance with the requirements as stated.

Vendor's Name: Danhill Construction Company
Authorized Signature: Robert D. Hill Date: 4/21/2009