



State of West Virginia
 Department of Administration
 Purchasing Division
 2019 Washington Street East
 Post Office Box 50130
 Charleston, WV 25305-0130

**Request for
 Quotation**

RFQ NUMBER
BCF90128

PAGE
1

ADDRESS CORRESPONDENCE TO ATTENTION OF:
ROBERTA WAGNER 304-558-0067



**STUART DESIGN
 GROUP**

SMART STORAGE SOLUTIONS

P.O. Box 710 • Greensburg, PA 15601
 1.800.989.4566 • www.stuartdesigngroup.com

HEALTH AND HUMAN RESOURCES
 VARIOUS LOCATIONS
 AS INDICATED BELOW

DATE PRINTED	TERMS OF SALE	SHIP VIA	F.O.B.	FREIGHT TERMS
03/18/2009	Net 30	BEST WAY	DESTINATION	Pre-Paid

BID OPENING DATE:	BID OPENING TIME
04/02/2009	01:30PM

LINE	QUANTITY	UOP	CAT NO	ITEM NUMBER	UNIT PRICE	AMOUNT
***** BID BOND AND DRUG FREE WORKPLACE CONFORMANCE AFFIDAVIT ARE REQUIRED WITH BID SUBMISSION. *****						
0001	1	JB		425-68	44,998. ⁰⁰	44,998. ⁰⁰
MANUAL, LATERAL, HIGH DENSITY FILING SYSTEM						
INQUIRIES: WRITTEN QUESTIONS SHALL BE ACCEPTED THROUGH CLOSE OF BUSINESS ON 3/25/2009. QUESTIONS MAY BE SENT VIA USPS, FAX, COURIER OR E-MAIL. IN ORDER TO ASSURE NO VENDOR RECEIVES AN UNFAIR ADVANTAGE, NO SUBSTANTIVE QUESTIONS WILL BE ANSWERED ORALLY. IF POSSIBLE, E-MAIL QUESTIONS ARE PREFERRED. ADDRESS INQUIRIES TO: ROBERTA WAGNER DEPARTMENT OF ADMINISTRATION PURCHASING DIVISION 2019 WASHINGTON STREET, EAST CHARLESTON, WV 25311 FAX: 304-558-4115 E-MAIL: ROBERTA.A.WAGNER@WV.GOV						

RECEIVED

2009 APR -1 P 12:16

PURCHASING DIVISION
 STATE OF WV

SEE REVERSE SIDE FOR TERMS AND CONDITIONS		
SIGNATURE <i>Andrew L. Stuart</i>	TELEPHONE 800-989-4566 x 2	DATE 03-30-09
TITLE President	PEIN 251493417	ADDRESS CHANGES TO BE NOTED ABOVE

WHEN RESPONDING TO RFQ, INSERT NAME AND ADDRESS IN SPACE ABOVE LABELED 'VENDOR'



State of West Virginia
 Department of Administration
 Purchasing Division
 2019 Washington Street East
 Post Office Box 50130
 Charleston, WV 25305-0130

Request for Quotation

RFQ NUMBER
BCF90128

PAGE
2

ADDRESS CORRESPONDENCE TO ATTENTION OF
ROBERTA WAGNER
304-558-0067



STUART DESIGN GROUP

SMART STORAGE SOLUTIONS

P.O. Box 710 • Greensburg, PA 15601
 1.800.989.4566 • www.stuartdesigngroup.com

SHIP TO

HEALTH AND HUMAN RESOURCES
 VARIOUS LOCATIONS
 AS INDICATED BELOW

DATE PRINTED	TERMS OF SALE	SHIP VIA	FOB	FREIGHT TERMS
03/18/2009				

BID OPENING DATE: **04/02/2009** BID OPENING TIME: **01:30PM**

LINE	QUANTITY	UOP	CAT NO	ITEM NUMBER	UNIT PRICE	AMOUNT
<p>THE MODEL/BRAND/SPECIFICATIONS NAMED HEREIN ESTABLISH THE ACCEPTABLE LEVEL OF QUALITY ONLY AND ARE NOT INTENDED TO REFLECT A PREFERENCE OR FAVOR ANY PARTICULAR BRAND OR VENDOR. VENDORS WHO ARE BIDDING ALTERNATES SHOULD SO STATE AND INCLUDE PERTINENT LITERATURE AND SPECIFICATIONS. FAILURE TO PROVIDE INFORMATION FOR ANY ALTERNATES MAY BE GROUNDS FOR REJECTION OF THE BID. THE STATE RESERVES THE RIGHT TO WAIVE MINOR IRREGULARITIES IN BIDS OR SPECIFICATIONS IN ACCORDANCE WITH SECTION 148-1-4(F) OF THE WEST VIRGINIA LEGISLATIVE RULES AND REGULATIONS.</p> <p>EXHIBIT 5</p> <p>NOTICE TO PROCEED: THIS CONTRACT IS TO BE PERFORMED WITHIN 90 CALENDAR DAYS AFTER THE NOTICE TO PROCEED IS RECEIVED. PLEASE NOTE THAT THE PURCHASE ORDER IS THE NOTICE TO PROCEED.</p> <p>CANCELLATION: THE DIRECTOR OF PURCHASING RESERVES THE RIGHT TO CANCEL THIS CONTRACT IMMEDIATELY UPON WRITTEN NOTICE TO THE VENDOR IF THE MATERIALS OR WORKMANSHIP SUPPLIED ARE OF AN INFERIOR QUALITY OR DO NOT CONFORM WITH THE SPECIFICATIONS OF THE BID AND CONTRACT HERE IN.</p> <p>WAGE RATES: THE CONTRACTOR OR SUBCONTRACTOR SHALL PAY THE HIGHER OF THE U.S. DEPARTMENT OF LABOR MINIMUM WAGE RATES AS ESTABLISHED FOR MARION COUNTY, PURSUANT TO WEST VIRGINIA CODE 21-5A, ET, SEQ. (PREVAILING WAGE RATES APPLY TO THIS PROJECT)</p>						

SEE REVERSE SIDE FOR TERMS AND CONDITIONS

SIGNATURE <i>Robert Wagner</i>	TELEPHONE 800-989-4566 x 2	DATE 03-30-09
TITLE President	FEB 25 1493417	ADDRESS CHANGES TO BE NOTED ABOVE

WHEN RESPONDING TO RFQ, INSERT NAME AND ADDRESS IN SPACE ABOVE LABELED 'VENDOR'



State of West Virginia
 Department of Administration
 Purchasing Division
 2019 Washington Street East
 Post Office Box 50130
 Charleston, WV 25305-0130

Request for Quotation

RFQ NUMBER
 BCF90128

PAGE
 3

ADDRESS CORRESPONDENCE TO ATTENTION OF
 ROBERTA WAGNER
 804-558-0067

S H I P T O



STUART DESIGN GROUP

SMART STORAGE SOLUTIONS

P.O. Box 710 • Greensburg, PA 15601
 1.800.989.4566 • www.stuartdesigngroup.com

S H I P T O

HEALTH AND HUMAN RESOURCES
 VARIOUS LOCATIONS
 AS INDICATED BELOW

DATE PRINTED	TERMS OF SALE	SHIP VIA	FOB	FREIGHT TERMS
03/18/2009				

BID OPENING DATE:

04/02/2009

BID OPENING TIME

01:30PM

LINE	QUANTITY	UOP	CAT. NO.	ITEM NUMBER	UNIT PRICE	AMOUNT
<p>ARBITRATION: ANY REFERENCES MADE TO ARBITRATION OR INTEREST FOR PAYMENTS DUE (EXCEPT FOR ANY INTEREST REQUIRED BY STATE LAW) CONTAINED IN THIS CONTRACT OR IN ANY AMERICAN INSTITUTE OF ARCHITECTS DOCUMENTS PERTAINING TO THIS CONTRACT ARE HEREBY DELETED.</p> <p>WORKERS' COMPENSATION: VENDOR IS REQUIRED TO PROVIDE A CERTIFICATE FROM WORKERS' COMPENSATION IF SUCCESSFUL.</p> <p>ALL OF THE ITEMS CHECKED BELOW WILL BE A REQUIREMENT OF THIS CONTRACT:</p> <p>(XX) INSURANCE: SUCCESSFUL VENDOR SHALL FURNISH PROOF OF COMMERCIAL GENERAL LIABILITY INSURANCE PRIOR TO ISSUANCE OF CONTRACT. UNLESS OTHERWISE SPECIFIED IN THE BID DOCUMENTS, THE MINIMUM AMOUNT OF INSURANCE COVERAGE REQUIRED IS \$250,000.</p> <p>(XX) BONDS: FIVE PERCENT (5%) OF THE TOTAL AMOUNT OF THE BID PAYABLE TO THE STATE OF WEST VIRGINIA, SHALL BE SUBMITTED WITH EACH BID AS A BID BOND. THE SUCCESSFUL BIDDER SHALL ALSO FURNISH A PERFORMANCE BOND AND LABOR/MATERIAL BOND FOR 100% OF THE AMOUNT OF THE CONTRACT. BONDS MAY BE PROVIDED IN THE FORM OF A CERTIFIED CHECK IRREVOCABLE LETTER OF CREDIT, OR BOND FURNISHED BY A SOLVENT SURETY COMPANY AUTHORIZED TO DO BUSINESS IN THE STATE OF WEST VIRGINIA. A LETTER OF CREDIT SUBMITTED IN LIEU OF A PERFORMANCE AND LABOR & MATERIAL BOND WILL ONLY BE ALLOWED FOR PROJECTS UNDER \$100,000. PERSONAL OR BUSINESS CHECKS ARE NOT ACCEPABLE IN LIEU OF THE 5% BID BOND, PERFORMANCE BOND, OR LABOR AND MATERIAL BOND.</p> <p>REV. 11/00</p>						

SEE REVERSE SIDE FOR TERMS AND CONDITIONS

SIGNATURE <i>Robert Wagner</i>	TELEPHONE 800-989-4566 x 2	DATE 03-30-09
TITLE President	FEIN 251493417	ADDRESS CHANGES TO BE NOTED ABOVE

WHEN RESPONDING TO RFQ, INSERT NAME AND ADDRESS IN SPACE ABOVE LABELED 'VENDOR'



State of West Virginia
 Department of Administration
 Purchasing Division
 2019 Washington Street East
 Post Office Box 50130
 Charleston, WV 25305-0130

Request for Quotation

RFQ NUMBER
BCE90128

PAGE
4

ADDRESS CORRESPONDENCE TO ATTENTION OF
ROBERTA WAGNER 304-558-0067

PROPERTY

RFQ COPY
 TYPE NAME/ADDRESS HERE
 Stuart Design Group, Inc
 P.O. Box 710
 Greensburg, PA 15601

SHIP TO

HEALTH AND HUMAN RESOURCES
 VARIOUS LOCATIONS
 AS INDICATED BELOW

DATE PRINTED	TERMS OF SALE	SHIP VIA	F.O.B.	FREIGHT TERMS
03/18/2009				

BID OPENING DATE: 04/02/2009 BID OPENING TIME: 01:30PM

LINE	QUANTITY	UOP	CAT NO	ITEM NUMBER	UNIT PRICE	AMOUNT
EXHIBIT 7						
DOMESTIC ALUMINUM, GLASS & STEEL IN PUBLIC WORKS PROJECTS IN ACCORDANCE WITH WEST VIRGINIA CODE 5-19-1 ET., SEQ., EVERY CONTRACT FOR CONSTRUCTION, RECONSTRUCTION, ALTERATION, REPAIR, IMPROVEMENT OR MAINTENANCE OF PUBLIC WORKS, WHERE THE COST IS MORE THAN \$50,000 AND, IN THE CASE OF STEEL ONLY, WHERE THE COST OF STEEL IS MORE THAN \$50,000 OR WHERE MORE THAN 10,000 POUNDS OF STEEL ARE REQUIRED, THE STATE WILL ACCEPT ONLY ALUMINUM GLASS, OR STEEL PRODUCTS PRODUCED IN THE UNITED STATES. IN ADDITION, ITEMS OF MACHINERY OR EQUIPMENT PURCHASED FOR USE AT THE SITE OF PUBLIC WORKS SHALL BE MADE OF DOMESTIC ALUMINUM, GLASS OR STEEL, UNLESS THE COST OF THE PRODUCT IS LESS THAN \$50,000 OR LESS THAN 10,000 POUNDS OF STEEL ARE USED IN PUBLIC WORKS PROJECTS. FOREIGN MADE ALUMINUM, GLASS OR STEEL PRODUCTS MAY BE ACCEPTED ONLY IF THE COST OF DOMESTIC PRODUCTS IS FOUND TO BE UNREASONABLE. SUCH COST IS UNREASONABLE IF IT IS 20% OR MORE HIGHER THAN THE BID PRICE FOR FOREIGN MADE PRODUCTS. IF THE DOMESTIC ALUMINUM, GLASS OR STEEL PRODUCTS TO BE SUPPLIED OR PRODUCED IN A "SUBSTANTIAL LABOR SURPLUS AREA", AS DEFINED BY THE UNITED STATES DEPARTMENT OF LABOR, FOREIGN PRODUCTS MAY BE SUPPLIED ONLY IF DOMESTIC PRODUCTS ARE 30% OR MORE HIGHER IN PRICE THAN THE FOREIGN MADE PRODUCTS. IF, PRIOR TO THE AWARD OF A CONTRACT UNDER THE ABOVE PROVISIONS, THE SPENDING OFFICER OF THE SPENDING UNIT DETERMINES THAT THERE EXISTS A BID FOR LIKE FOREIGN ALUMINUM, GLASS OR STEEL THAT IS REASONABLE AND LOWER THAN THE LOWEST BID DOMESTIC PRODUCTS, THE SPENDING OFFICE MAY REQUEST, IN WRITING, A REEVALUATION AND						

SIGNATURE		TELEPHONE		DATE
<i>[Signature]</i>		800-989-4566 x 2		03-30-09
TITLE	FEIN	ADDRESS CHANGES TO BE NOTED ABOVE		
resident	25 1493417			

WHEN RESPONDING TO RFQ, INSERT NAME AND ADDRESS IN SPACE ABOVE LABELED 'VENDOR'



State of West Virginia
 Department of Administration
 Purchasing Division
 2019 Washington Street East
 Post Office Box 50130
 Charleston, WV 25305-0130

**Request for
 Quotation**

RFQ NUMBER
BCF90128

PAGE
5

ADDRESS CORRESPONDENCE TO ATTENTION OF
**ROBERTA WAGNER
 804-558-0067**

PROBITY



**STUART DESIGN
 GROUP**

SMART STORAGE SOLUTIONS

P.O. Box 710 • Greensburg, PA 15601
 1.800.989.4566 • www.stuartdesigngroup.com

SHIP TO

HEALTH AND HUMAN RESOURCES
 VARIOUS LOCATIONS
 AS INDICATED BELOW

DATE PRINTED: 03/18/2009	TERMS OF SALE	SHIP VIA	F.O.B.	FREIGHT TERMS
------------------------------------	---------------	----------	--------	---------------

BID OPENING DATE: **04/02/2009** BID OPENING TIME **01:30PM**

LINE	QUANTITY	UOP	CAT. NO.	ITEM NUMBER	UNIT PRICE	AMOUNT
<p>REDUCTION IN THE LOWEST BID FOR SUCH DOMESTIC PRODUCTS. ALL VENDORS MUST INDICATE IN THEIR BID IF THEY ARE SUPPLYING FOREIGN ALUMINUM, GLASS OR STEEL.</p> <p>EXHIBIT 10</p> <p>ADDENDUM ACKNOWLEDGEMENT</p> <p>I HEREBY ACKNOWLEDGE RECEIPT OF THE FOLLOWING CHECKED ADDENDUM(S) AND HAVE MADE THE NECESSARY REVISIONS TO MY PROPOSAL, PLANS AND/OR SPECIFICATION, ETC.</p> <p>ADDENDUM NOS.:</p> <p>NO. 1 ✓</p> <p>NO. 2</p> <p>NO. 3</p> <p>NO. 4</p> <p>NO. 5</p> <p>I UNDERSTAND THAT FAILURE TO CONFIRM THE RECEIPT OF THE ADDENDUM(S) MAY BE CAUSE FOR REJECTION OF THE BIDS.</p> <p><i>[Signature]</i> SIGNATURE</p> <p>STUART DESIGN GROUP COMPANY</p> <p>..... DATE</p> <p>REV. 11/96</p>						

SEE REVERSE SIDE FOR TERMS AND CONDITIONS

SIGNATURE <i>[Signature]</i>	TELEPHONE 800-989-4566 x 2	DATE 03-30-09
TITLE President	FEN 25 1493417	ADDRESS CHANGES TO BE NOTED ABOVE

WHEN RESPONDING TO RFQ, INSERT NAME AND ADDRESS IN SPACE ABOVE LABELED 'VENDOR'



State of West Virginia
 Department of Administration
 Purchasing Division
 2019 Washington Street East
 Post Office Box 50130
 Charleston, WV 25305-0130

Request for Quotation

RFQ NUMBER
BCF90128

PAGE
6

ADDRESS CORRESPONDENCE TO ATTENTION OF
ROBERTA WAGNER
~~304-558-0067~~



STUART DESIGN GROUP
 SMART STORAGE SOLUTIONS

P.O. Box 710 • Greensburg, PA 15601
 1.800.989.4566 • www.stuartdesigngroup.com

S H P T O

HEALTH AND HUMAN RESOURCES
 VARIOUS LOCATIONS
 AS INDICATED BELOW

DATE PRINTED	TERMS OF SALE	SHIP VIA	FOB	FREIGHT TERMS
03/18/2009				

BID OPENING DATE: 04/02/2009 BID OPENING TIME: 01:30PM

LINE	QUANTITY	UOP	CAT NO	ITEM NUMBER	UNIT PRICE	AMOUNT
<p>CONTRACTORS LICENSE</p> <p>WEST VIRGINIA STATE CODE 21-11-2 REQUIRES THAT ALL PERSONS DESIRING TO PERFORM CONTRACTING WORK IN THIS STATE MUST BE LICENSED. THE WEST VIRGINIA CONTRACTORS LICENSING BOARD IS EMPOWERED TO ISSUE THE CONTRACTORS LICENSE. APPLICATIONS FOR A CONTRACTORS LICENSE MAY BE MADE BY CONTACTING THE WEST VIRGINIA DIVISION OF LABOR CAPITOL COMPLEX, BUILDING 3, ROOM 319, CHARLESTON, WV 25305. TELEPHONE: (304) 558-7890.</p> <p>WEST VIRGINIA STATE CODE 21-11-11 REQUIRES ANY PROSPECTIVE BIDDER TO INCLUDE THE CONTRACTORS LICENSE NUMBER ON THEIR BID.</p> <p>BIDDER TO COMPLETE:</p> <p>CONTRACTORS NAME: <i>Stuart Design Group, Inc.</i></p> <p>CONTRACTORS LICENSE NO.: <i>WV031242</i></p> <p>THE SUCCESSFUL BIDDER WILL BE REQUIRED TO FURNISH A COPY OF THEIR CONTRACTORS LICENSE PRIOR TO ISSUANCE OF A PURCHASE ORDER/CONTRACT</p> <p style="text-align: center;">APPLICABLE LAW</p> <p>THE WEST VIRGINIA STATE CODE, PURCHASING DIVISION RULE AND REGULATIONS, AND THE INFORMATION PROVIDED IN THE "REQUEST FOR QUOTATION" ISSUED BY THE PURCHASING DIVISION IS THE SOLE AUTHORITY GOVERNING THIS PROCUREMENT.</p> <p>ANY INFORMATION PROVIDED IN SPECIFICATION MANUALS, OR</p>						

SEE REVERSE SIDE FOR TERMS AND CONDITIONS

SIGNATURE <i>[Signature]</i>	TELEPHONE 800-989-4566 x 2	DATE 03-30-09
TITLE President	FEIN 25 149 3417	ADDRESS CHANGES TO BE NOTED ABOVE

WHEN RESPONDING TO RFQ, INSERT NAME AND ADDRESS IN SPACE ABOVE LABELED 'VENDOR'



State of West Virginia
 Department of Administration
 Purchasing Division
 2019 Washington Street East
 Post Office Box 50130
 Charleston, WV 25305-0130

Request for Quotation

RFQ NUMBER
BCF90128

PAGE
7

ADDRESS CORRESPONDENCE TO ATTENTION OF:
ROBERTA WAGNER
804-558-0067

PRIORITY

RFQ COPY
 TYPE NAME/ADDRESS HERE
Stuart Design Group, Inc.
P.O. Box 710
Greensburg PA. 15601

S H P T O

HEALTH AND HUMAN RESOURCES
 VARIOUS LOCATIONS
 AS INDICATED BELOW

DATE PRINTED	TERMS OF SALE	SHIP VIA	F.O.B.	FREIGHT TERMS
03/18/2009				

BID OPENING DATE: **04/02/2009** BID OPENING TIME **01:30PM**

LINE	QUANTITY	UOP	CAT NO	ITEM NUMBER	UNIT PRICE	AMOUNT
<p>ANY OTHER SOURCE, VERBAL OR WRITTEN, WHICH CONTRADICTS OR ALTERS THE INFORMATION PROVIDED FROM THE SOURCES AS DESCRIBED IN THE ABOVE PARAGRAPH IS VOID AND OF NO EFFECT.</p> <p>BANKRUPTCY: IN THE EVENT THE VENDOR/CONTRACTOR FILES FOR BANKRUPTCY PROTECTION, THIS CONTRACT IS AUTOMATICALLY NULL AND VOID, AND IS TERMINATED WITHOUT FURTHER ORDER.</p> <p>REV. 1/2005</p> <p style="text-align: center;">NOTICE</p> <p>AN ORIGINAL, SIGNED BID MUST BE SUBMITTED TO:</p> <p style="text-align: center;">DEPARTMENT OF ADMINISTRATION PURCHASING DIVISION BUILDING 15 2019 WASHINGTON STREET, EAST CHARLESTON, WV 25305-0130</p> <p>THE BIDS MUST CONTAIN THIS INFORMATION ON THE FACE OF THE ENVELOPES OR THE BIDS MAY NOT BE CONSIDERED:</p> <p>SEALED BID</p> <p>BUYER: RW-22</p> <p>REQ. NO.: BCF90128</p> <p>BID OPENING DATE AND TIME: 04/02/2009 @ 1:30 PM</p> <p>PLEASE NOTE: A CONVENIENCE COPY WOULD BE APPRECIATED. PLEASE PROVIDE A FAX NUMBER IN CASE IT IS NECESSARY</p>						

SEE REVERSE SIDE FOR TERMS AND CONDITIONS

SIGNATURE <i>[Signature]</i>	TELEPHONE 800-989-4566 x 2	DATE 03-30-09
TITLE President	FEIN 251493417	ADDRESS CHANGES TO BE NOTED ABOVE

WHEN RESPONDING TO RFQ, INSERT NAME AND ADDRESS IN SPACE ABOVE LABELED 'VENDOR'



State of West Virginia
 Department of Administration
 Purchasing Division
 2019 Washington Street East
 Post Office Box 50130
 Charleston, WV 25305-0130

Request for Quotation

RFQ NUMBER: BCF90128

PAGE 8

ADDRESS CORRESPONDENCE TO ATTENTION OF: ROBERTA WAGNER 304-558-0067

VENDOR



STUART DESIGN GROUP

SMART STORAGE SOLUTIONS

P.O. Box 710 • Greensburg, PA 15601
 1.800.989.4566 • www.stuartdesigngroup.com

SHIP TO

HEALTH AND HUMAN RESOURCES
 VARIOUS LOCATIONS
 AS INDICATED BELOW

DATE PRINTED	TERMS OF SALE	SHIP VIA	FOB	FREIGHT TERMS
03/18/2009				

BID OPENING DATE: 04/02/2009 BID OPENING TIME 01:30PM

LINE	QUANTITY	UOP	CAT NO	ITEM NUMBER	UNIT PRICE	AMOUNT
<p>TO CONTACT YOU REGARDING YOUR BID: <u>800-989-4566 x 2</u></p> <p>PLEASE PRINT OR TYPE NAME OF PERSON TO CONTACT CONCERNING THIS QUOTE: <u>ANDREW L. STUART</u></p> <p>PLEASE NOTE: A CONVENIENCE COPY WOULD BE APPRECIATED.</p>						
***** THIS IS THE END OF RFQ BCF90128 ***** TOTAL:						<p><u>44,998.⁰⁰</u></p>

SEE REVERSE SIDE FOR TERMS AND CONDITIONS		
SIGNATURE <i>[Signature]</i>	TELEPHONE 800-989-4566 x 2	DATE 03-30-09
TITLE President	FEIN 25 1493417	ADDRESS CHANGES TO BE NOTED ABOVE

WHEN RESPONDING TO RFQ, INSERT NAME AND ADDRESS IN SPACE ABOVE LABELED 'VENDOR'

**REQUEST FOR QUOTATION
BCF90128**

PART 1 GENERAL

1.1 Request for Quotation to provide all labor, material and anything incidental to the acquisition and installation of a fully complete lockable Kardex Kompakt or equal, manual, lateral, high density filing system as defined herein for the Marion County office location of the Department of Health & Human Resources. The system must be manually operated and accommodate the approximate stated amount of linear filing inches as specified for 8 1/2" x 11" documents. All work will be in compliance with Fire Marshall regulations and all other building codes and industry standards. The award will be made to the overall low bid that complies with the specifications.

1.2 The following is the location where the file system is to be installed and the approximate size of the system. This is a Mall building currently under renovation and the builder estimates the building will be ready for the file system to be installed on or about May 1, 2009. Bidders - Please note: Your bid can be for more linear file inches than what is requested but bids with less linear file inches will be disqualified.

1.2.1 MARION COUNTY DHHR 27,000 linear filing inches
9395 Middletown Mall
White Hall, WV 26554

1.2.2 The space plan allows the file system to have a footprint of 30'w x 20'd in order to fit in the room. A floor plan is attached showing the file system in the center with the wording: "Clerical Pool Record Room." This area is the actual file system footprint and the plan allows for the actual size of 30'- 10" w x 20' d.

1.3 It is the bidder's responsibility to verify all field conditions and building weight limitations prior to bidding. It is also the bidder's responsibility to notify the West Virginia Department of Health & Human Resources in writing, of conditions detrimental to proper and timely completion of the installation. Do not proceed until nonconforming conditions have been corrected.

1.4 The intent of this Request for Quotation is to provide the using office with a high quality, mobile lateral filing system. The foregoing specifications are to be considered nominal and approximate. Minor deviations from the stated specifications are acceptable to facilitate a competitive bid atmosphere provided the intent of the Request for Quotation or the effectiveness of the system is not compromised. No deviation is permitted on the space or configuration requirements. **ALL VENDORS PLEASE NOTE: This system is to be 100% complete. All braces, dividers or any other component necessary to properly utilize the filing system will be included with the initial installation at the offered price. This is not negotiable and payment will not be made to the vendor if they should fail in any way to meet this requirement.**

PART 2 TECHNICAL SPECIFICATIONS

2.1 TRACKS: Each modular track assembly will consist of two 14 gauge formed steel rails capable of carrying a minimum load of 1000 pounds per linear foot. The rail assembly will be welded to a minimum of 4 corresponding 14 gauge steel support channels. Track assemblies are leveled by adjusting built-in leveling glides found in the support channel located every 12 inches on center. End stops are installed at each end of the rail assemble to provide a safe, cushioned stop for the mobile carriage. All track assemblies will include a stainless steel decorative cap. This cap will be attached to the front of the track assembly giving it a finished profile.

2.2 CARRIAGES: Carriages consist of sections of "U" shaped formed cold roll steel 13 gauge and 14 gauge stringers and cross members, all electrically welded to form a strong and durable frame. **Each seam will be fully welded. Occasional spot welds that allow the sheet metal surface to bow between welds are unacceptable.**

2.3 WHEELS: Carriage wheels will be double-flanged and 5" in diameter with each wheel having heavy-duty, double sealed, permanently lubricated, ball bearings. There are a total of four wheel assemblies per carriage.

2.4 FINISH: All steel parts are thoroughly cleaned in a three stage iron phosphate washer. Each steel component is then coated with an epoxy powder coat finish using an electrostatic paint system. This paint system ensures a long lasting and durable finish. The end user will make color choice.

2.5 DECKING: Decking will be installed so the tracks will be level with the floor surface. The decking will be as recommended by the filing system manufacturer and will be covered with a finish flooring material. If the filing system manufacturer does not provide a covering, the decking will be covered consistent with surrounding flooring.

2.6 WORKING HEIGHT: The maximum height of the top shelf shall not be higher than what can be accessed by a 5' 2" person. **Total installed height not to exceed 76" and that is nonnegotiable.**

2.7 REFERENCE SHELF: There shall be one retractable reference shelf located approximately 38" above the floor surface on each side of each aisle at a point towards the aisle center. The shelf should be capable of holding ten pounds of weight at a fully open position.

2.8 INSTALLATION LOCATION: The system shall be installed in the location known as the Clerical Pool Record room. The room was constructed to accommodate a file system measuring approximately 30'w x 20'd and the proposed system cannot exceed the size limitations of the room including properly sized walk ways and the aisles as required in section 2.10.

2.9 UNDERCARRIAGE ANTI-TIP: For safe operation of the system, an undercarriage anti-tip device shall be provided and bolted to the carriage that has a lip riding in the

flange on each rail, (2 per wheel). Anti-tip angles must be constructed of no less than 11 gauge steel and must have a bottom flange (interlocking with rail) of no less than 7/8" wide. Overhead mounted products are unacceptable.

2.10 AISLES: Aisle requirements are minimum distances from a fully open position. The system will be configured to provide two 36" aisles.

2.11 SHELF DIVIDERS: A minimum of three shelf dividers shall be provided with each shelf opening.

2.12 CONTROLS: The system shall be designed so that the entire file system can be closed by turning the handle on the last shelf unit. The last shelf unit will push all open shelf units to a closed position. The system will be capable of being locked in the closed position.

2.13 WARRANTY AND RESPONSE TIME: Please state the warranty period of the system bid and the response time for warranted and non-warranted repairs. As a mandatory minimum, a response time of 48 hours is requested and nothing less than a one year warranty is acceptable.

PART 3 SPECIAL CONDITIONS

3.1 The contractor shall coordinate all site activities with a designated representative from the physical location.

3.2 The contractor shall be adequately bonded and insured to fully indemnify and hold harmless the property owner and/or the Department of Health & Human Resources from and against any and all claims arising from the performance of this contract.

3.3 The contractor shall complete all work within 90 calendar days after receiving the notice to proceed.

3.4 One payment shall be made at 100% completion pending acceptance by the Department of Health and Human Resources. The Department of Health & Human Resources reserves the right to withhold payment if the installed system is not in compliance with the specifications.

3.5 The contractor shall pay the higher of the U.S Department of Labor minimum wage rates for all labor performed on site as established for Marion County pursuant to West Virginia Code 21-5-1, et. seq.

3.6 Bidders shall submit one lump-sum base bid for all work and equipment under all the terms and conditions as described herein.



State of West Virginia
DRUG FREE WORKPLACE CONFORMANCE AFFIDAVIT
West Virginia Code §21-1D-5

STATE OF PA

COUNTY OF Westmoreland TO-WIT:

I, Andrew L. Stuart, after being first duly sworn, depose and state as follows:

1. I am an employee of Stuart Design Group, Inc; and,
(Company Name)
2. I do hereby attest that Stuart Design Group, Inc
(Company Name)

maintains a valid written drug free workplace policy and that such policy is in compliance with **West Virginia Code §21-1D-5.**

The above statements are sworn to under the penalty of perjury.

Stuart Design Group, Inc.
(Company Name)

By: [Signature]

Title: President

Date: 03-31-09

Taken, subscribed and sworn to before me this 31st day of March 2009

By Commission expires 11/09/10

COMMONWEALTH OF PENNSYLVANIA
Notarial Seal
Sharon R. Jack, Notary Public
Murrysville Boro, Westmoreland County
My Commission Expires Nov. 9, 2010

[Signature]
(Notary Public)

THIS AFFIDAVIT MUST BE SUBMITTED WITH THE BID IN ORDER TO COMPLY WITH WV CODE PROVISIONS. FAILURE TO INCLUDE THE AFFIDAVIT WITH THE BID SHALL RESULT IN DISQUALIFICATION OF THE BID.

RFQ No. BCF90128

STATE OF WEST VIRGINIA
Purchasing Division

PURCHASING AFFIDAVIT

VENDOR OWING A DEBT TO THE STATE:

West Virginia Code §5A-3-10a provides that: No contract or renewal of any contract may be awarded by the state or any of its political subdivisions to any vendor or prospective vendor when the vendor or prospective vendor or a related party to the vendor or prospective vendor is a debtor and the debt owed is an amount greater than one thousand dollars in the aggregate.

PUBLIC IMPROVEMENT CONTRACTS & DRUG-FREE WORKPLACE ACT:

If this is a solicitation for a public improvement construction contract, the vendor, by its signature below, affirms that it has a written plan for a drug-free workplace policy in compliance with Article 1D, Chapter 21 of the *West Virginia Code*. The vendor **must** make said affirmation with its bid submission. Further, public improvement construction contract may not be awarded to a vendor who does not have a written plan for a drug-free workplace policy in compliance with Article 1D, Chapter 21 of the *West Virginia Code* and who has not submitted that plan to the appropriate contracting authority in timely fashion. For a vendor who is a subcontractor, compliance with Section 5, Article 1D, Chapter 21 of the *West Virginia Code* may take place before their work on the public improvement is begun.

ANTITRUST:

In submitting a bid to any agency for the state of West Virginia, the bidder offers and agrees that if the bid is accepted the bidder will convey, sell, assign or transfer to the state of West Virginia all rights, title and interest in and to all causes of action it may now or hereafter acquire under the antitrust laws of the United States and the state of West Virginia for price fixing and/or unreasonable restraints of trade relating to the particular commodities or services purchased or acquired by the state of West Virginia. Such assignment shall be made and become effective at the time the purchasing agency tenders the initial payment to the bidder.

I certify that this bid is made without prior understanding, agreement, or connection with any corporation, firm, limited liability company, partnership or person or entity submitting a bid for the same materials, supplies, equipment or services and is in all respects fair and without collusion or fraud. I further certify that I am authorized to sign the certification on behalf of the bidder or this bid.

LICENSING:

Vendors must be licensed and in good standing in accordance with any and all state and local laws and requirements by any state or local agency of West Virginia, including, but not limited to, the West Virginia Secretary of State's Office, the West Virginia Tax Department, West Virginia Insurance Commission, or any other state agencies or political subdivision. Furthermore, the vendor must provide all necessary releases to obtain information to enable the Director or spending unit to verify that the vendor is licensed and in good standing with the above entities.

CONFIDENTIALITY:

The vendor agrees that he or she will not disclose to anyone, directly or indirectly, any such personally identifiable information or other confidential information gained from the agency, unless the individual who is the subject of the information consents to the disclosure in writing or the disclosure is made pursuant to the agency's policies, procedures and rules. Vendor further agrees to comply with the Confidentiality Policies and Information Security Accountability Requirements, set forth in <http://www.state.wv.us/admin/purchase/privacy/noticeConfidentiality.pdf>.

Under penalty of law for false swearing (*West Virginia Code* §61-5-3), it is hereby certified that the vendor affirms and acknowledges the information in this affidavit and is in compliance with the requirements as stated.

Vendor's Name: STUART DESIGN GROUP
Authorized Signature: [Signature] Date: 03-30-09

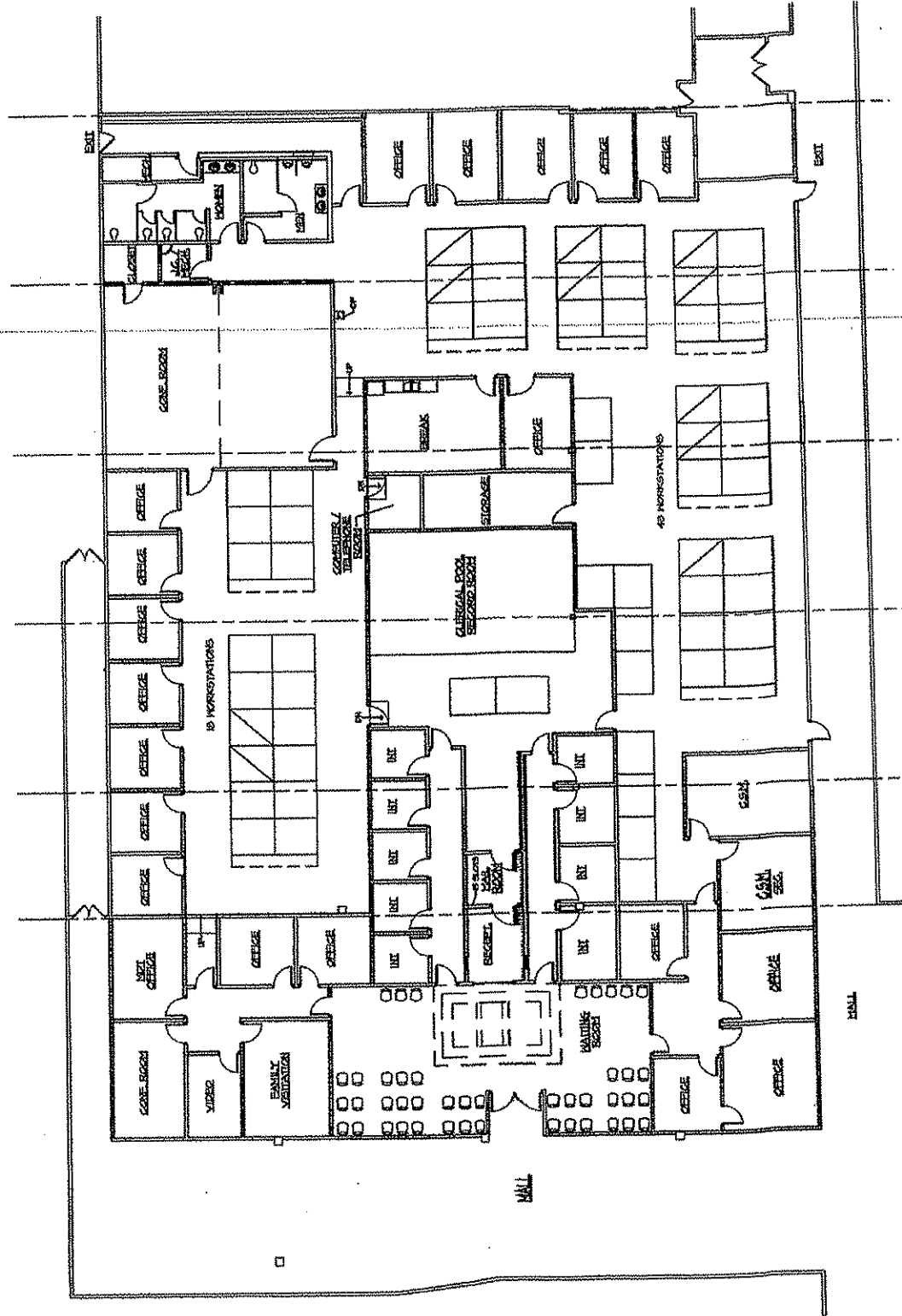

DHHR OFFICES
MIDDLETOWN MALL
3.6.2009

BCS FLOOR PLAN SUITE A 12,490 SF. 2

0' 8' 16' 32'



State of West Virginia
 Department of Administration
 Purchasing Division
 2019 Washington Street East
 Post Office Box 50130
 Charleston, WV 25305-0130

Request for Quotation

RFQ NUMBER
BCF90128

PAGE
1

ADDRESS CORRESPONDENCE TO ATTENTION OF:
ROBERTA WAGNER 304-558-0067

STUARD



STUART DESIGN GROUP

SMART STORAGE SOLUTIONS

P.O. Box 710 • Greensburg, PA 15601
 1.800.989.4566 • www.stuartdesigngroup.com

SHIP TO

HEALTH AND HUMAN RESOURCES
 VARIOUS LOCATIONS
 AS INDICATED BELOW

DATE PRINTED	TERMS OF SALE	SHIP VIA	F.O.B.	FREIGHT TERMS
03/27/2009				

BID OPENING DATE: 04/02/2009 BID OPENING TIME 01:30PM

LINE	QUANTITY	UOP	CAT. NO.	ITEM NUMBER	UNIT PRICE	AMOUNT
ADDENDUM NO. 1 1. QUESTIONS AND ANSWERS ARE ATTACHED. 2. ADDENDUM ACKNOWLEDGEMENT IS ATTACHED. THIS DOCUMENT SHOULD BE SIGNED AND RETURNED WITH YOUR BID. FAILURE TO SIGN AND RETURN MAY RESULT IN DISQUALIFICATION OF YOUR BID. EXHIBIT 10 REQUISITION NO.: BCF90128 ADDENDUM ACKNOWLEDGEMENT I HEREBY ACKNOWLEDGE RECEIPT OF THE FOLLOWING CHECKED ADDENDUM(S) AND HAVE MADE THE NECESSARY REVISIONS TO MY PROPOSAL, PLANS AND/OR SPECIFICATION, ETC. ADDENDUM NO. IS: NO. 1 ✓ NO. 2 NO. 3 NO. 4 NO. 5 UNDERSTAND THAT FAILURE TO CONFIRM THE RECEIPT OF THE ADDENDUM(S) MAY BE CAUSE FOR REJECTION OF BIDS. VENDOR MUST CLEARLY UNDERSTAND THAT ANY VERBAL						

SEE REVERSE SIDE FOR TERMS AND CONDITIONS

SIGNATURE	TELEPHONE	DATE
<i>[Signature]</i>	800-989-4566 x 2	03-30-09
TITLE	FERN	ADDRESS CHANGES TO BE NOTED ABOVE
<i>[Signature]</i>	25-1493417	

WHEN RESPONDING TO RFQ, INSERT NAME AND ADDRESS IN SPACE ABOVE LABELED 'VENDOR'



State of West Virginia
 Department of Administration
 Purchasing Division
 2019 Washington Street East
 Post Office Box 50130
 Charleston, WV 25305-0130

Request for Quotation

RFQ NUMBER: BCF90128

PAGE: 2

ADDRESS CORRESPONDENCE TO ATTENTION OF: ROBERTA WAGNER 304-558-0067

POSTAGE



STUART DESIGN GROUP
 SMART STORAGE SOLUTIONS

P.O. Box 710 • Greensburg, PA 15601
 1.800.989.4566 • www.stuartdesigngroup.com

POSTAGE

HEALTH AND HUMAN RESOURCES
 VARIOUS LOCATIONS
 AS INDICATED BELOW

DATE PRINTED	TERMS OF SALE	SHIP VIA	F.O.B.	FREIGHT TERMS
03/27/2009				

BID OPENING DATE: 04/02/2009	BID OPENING TIME: 01:30PM
------------------------------	---------------------------

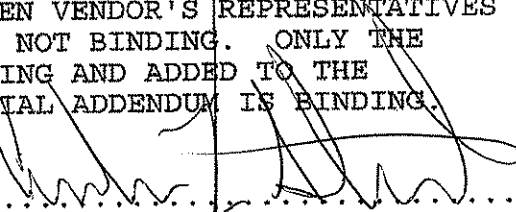
LINE	QUANTITY	UOP	CAT NO	ITEM NUMBER	UNIT PRICE	AMOUNT
<p>REPRESENTATION MADE OR ASSUMED TO BE MADE DURING ANY ORAL DISCUSSION HELD BETWEEN VENDOR'S REPRESENTATIVES AND ANY STATE PERSONNEL IS NOT BINDING. ONLY THE INFORMATION ISSUED IN WRITING AND ADDED TO THE SPECIFICATIONS BY AN OFFICIAL ADDENDUM IS BINDING.</p> <p style="text-align: center;">  SIGNATURE Stuart Design Group COMPANY 03-30-09 DATE </p> <p>REV. 11/96</p> <p style="text-align: center;">END OF ADDENDUM NO. 1</p>						

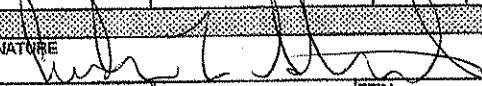
SEE REVERSE SIDE FOR TERMS AND CONDITIONS		
SIGNATURE 	TELEPHONE 300-989-4566 x2	DATE 03-30-09
TITLE President	FEIN 251493417	ADDRESS CHANGES TO BE NOTED ABOVE

WHEN RESPONDING TO RFQ, INSERT NAME AND ADDRESS IN SPACE ABOVE LABELED 'VENDOR'



State of West Virginia
 Department of Administration
 Purchasing Division
 2019 Washington Street East
 Post Office Box 50130
 Charleston, WV 25305-0130

Request for Quotation

RFQ NUMBER
BCF90128

PAGE
3

ADDRESS CORRESPONDENCE TO ATTENTION OF
ROBERTA WAGNER 304-558-0067

STUARD DESIGN GROUP



STUARD DESIGN GROUP

SMART STORAGE SOLUTIONS

P.O. Box 710 • Greensburg, PA 15601
 1.800.989.4566 • www.stuarddesigngroup.com

SHIP TO

HEALTH AND HUMAN RESOURCES
 VARIOUS LOCATIONS
 AS INDICATED BELOW

DATE PRINTED	TERMS OF SALE	SHIP VIA	F.O.B.	FREIGHT TERMS
03/27/2009				

BID OPENING DATE: 04/02/2009 BID OPENING TIME: 01:30PM

LINE	QUANTITY	UOP	CAT NO	ITEM NUMBER	UNIT PRICE	AMOUNT
0001	1	JB		425-68		\$ 44,998. ⁰⁰
				MANUAL, LATERAL, HIGH DENSITY FILING SYSTEM		
***** THIS IS THE END OF RFQ BCF90128 ***** TOTAL:						\$ 44,998. ⁰⁰

SEE REVERSE SIDE FOR TERMS AND CONDITIONS

SIGNATURE	TELEPHONE	DATE
<i>[Signature]</i>	800-989-4566 x 2	03-30-09
TITLE	FEN	ADDRESS CHANGES TO BE NOTED ABOVE
President	25 149 3417	

WHEN RESPONDING TO RFQ, INSERT NAME AND ADDRESS IN SPACE ABOVE LABELED 'VENDOR'

Addendum 1 to RFQ BCF90128

Response to Vendor Questions:

Question: 1) section 1.1 requests a MANUAL system. Should we assume that it is Mechanically operated with a 3 spoked handle control, (a chain turns a sprocket that turns the wheels)? Also, should the single sided Movable lockable unit be Mechanically operated?

Response: We refer to a manual system as one the operator turns a 3 spoked handle and the carriages move either left or right. The system is designed to close and lock so one single sided carriage should move and the other should be fixed.

Question: 2) section 1.3, will this equipment be installed on any other floor besides, the ground floor?
Response: No.

Question: 3) Is the existing floor concrete?
Response: Yes.

Question: 4) section 2.1, do you want the rails to be anchored to the floor, leveled and then grouted?
Response: Yes.

Question: 5) section 2.5, should we provide carpet that will be close in color to what is existing?
Response: Yes, the carpet is available locally so you should be able to make an exact match.

Question: 6) section 2.6, Are you stating that the shelving height may not exceed 76" high? Should we assume that you are requesting 7 openings plus a top?
Response: No, 6 openings.

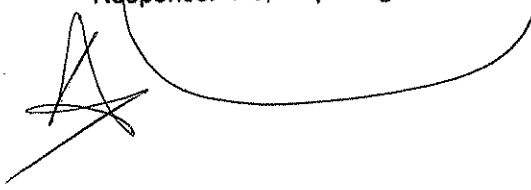
A handwritten signature consisting of several overlapping loops is located to the left of a large, hand-drawn oval. The oval encircles the text of question 6 and its response.

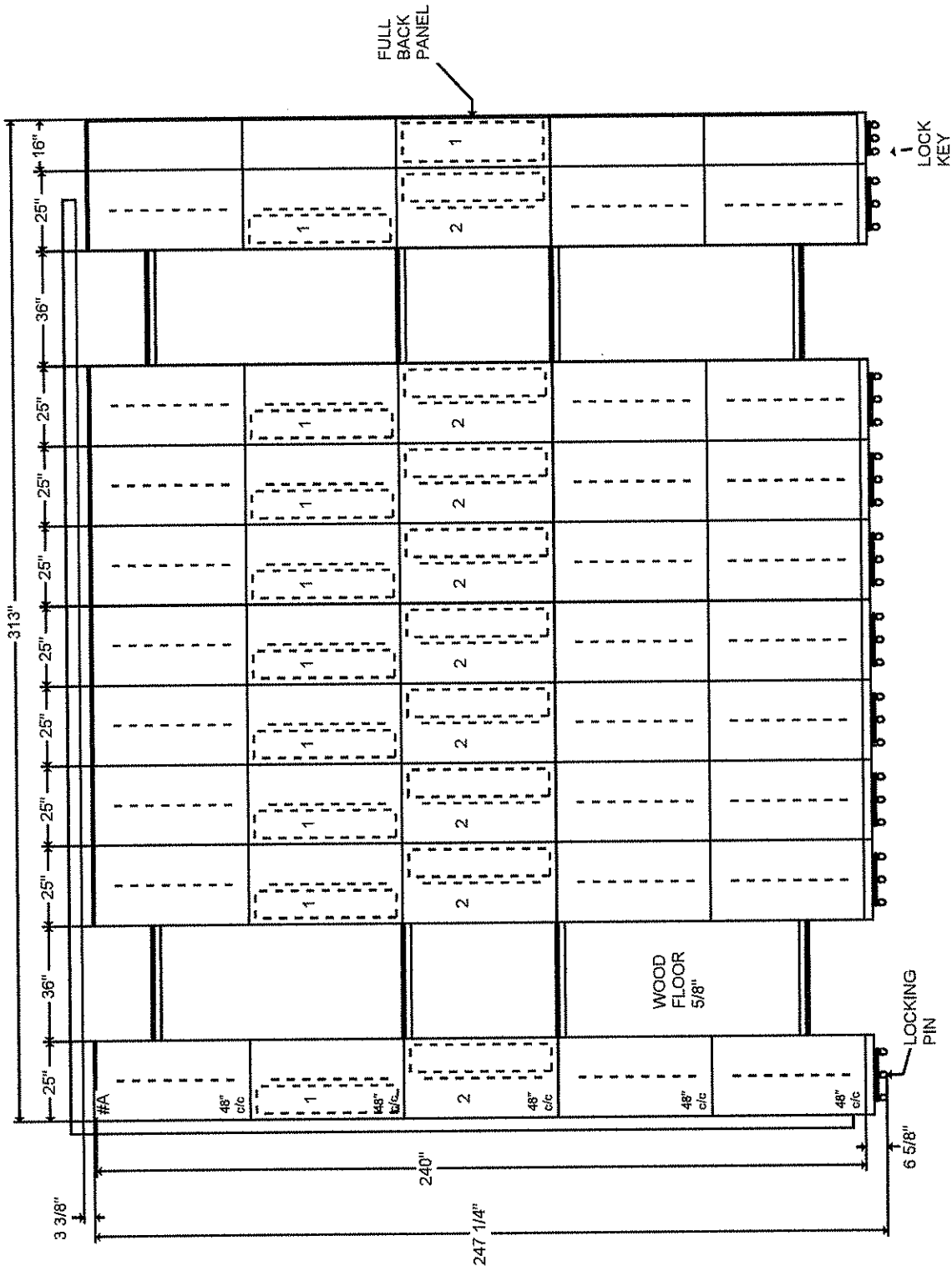

LEGEND

- SINGLE FACE FIXED ON FLOOR
- DOUBLE FACE FIXED ON FLOOR
- FIXED SINGLE FACE SHELVING
- FIXED DOUBLE FACE SHELVING
- MOBILE SINGLE FACE SHELVING
- MOBILE DOUBLE FACE SHELVING
- DOUBLE FACE PULLBACK
- SWAY BRACE
- HANDLE (FOR MECHANICAL SYSTEM)

Project Description :
 WEST VIRGINIA HEALTH & HUMAN RESOURCES

Address :
 STUART DESIGN GROUP
 ANDREW STUART

SDG JOB # : 6425A0309
 *** PA # : 1168 - EXPIRE :
 2009-04-24 ***

Project Name : LD090125
Distributor : MONTEL
View : GENERAL VIEW
Room : #1
*** Comments :** *VERIFY DIMENSION ON SITE

MONTEL
 The Intelligent Use of Space
 WWW.MONTEL.COM
 SYSTEM@MONTEL.COM
 1-877-535-0236 (USA)
 1-800-935-0235 (CAN)

ONLY DRAWINGS BEARING THE NUMBER OF THE ACKNOWLEDGEMENT OF ORDER ARE BINDING FOR THE EXECUTION

MoDraw User : idaigneaut
Printed : 2009-03-30
Last Modified : 2009-03-30
MoDraw Version : 3.6.35
Page : 1/6

This drawing contains proprietary and confidential information. Duplication, reproduction or use of this document or its content in any form other than as expressly permitted by Monel Inc. are strictly prohibited. ALL DIMENSIONS HAVE TO BE VERIFIED WITH ACTUAL SITE DIMENSIONS.

FRONT VIEW WITH PANEL

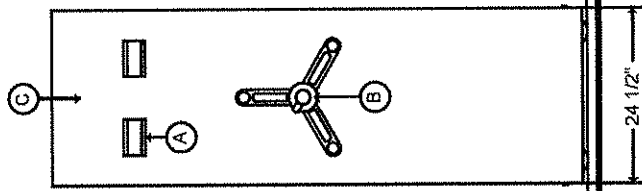

FRONT VIEW WITHOUT PANEL

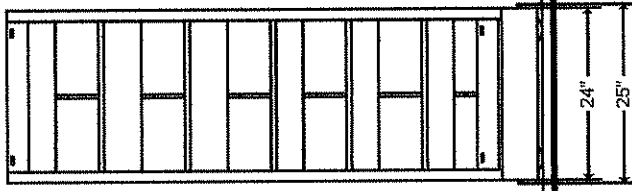

LEFT SIDE VIEW

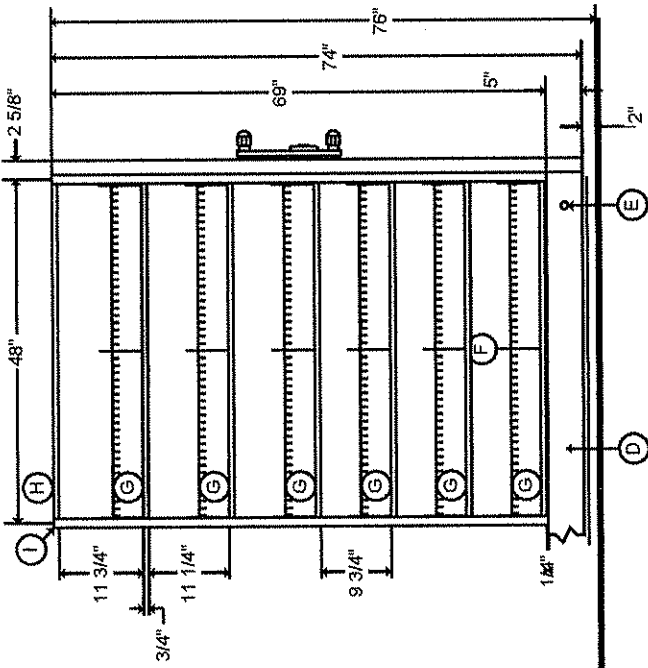

Legend

- A CARD HOLDER
- B LOCKING PIN
- C PANEL
- D CARRIAGE
- E BUMPER 1/2"
- F DIVIDER
- G QSC4824DFA SLOTTED BOX SHELF
- H QST4824SHA TOP SHELF
- I UPRIGHT CLOSING PARTITIONS

LEGEND

- SINGLE FACE FIXED ON FLOOR
- DOUBLE FACE FIXED ON FLOOR
- FIXED SINGLE FACE SHELVING
- FIXED DOUBLE FACE SHELVING
- MOBILE SINGLE FACE SHELVING
- MOBILE DOUBLE FACE SHELVING
- DOUBLE FACE FULLBACK
- SWAY BRACE
- HANDLE (FOR MECHANICAL SYSTEM)

Project Description :
 WEST VIRGINIA HEALTH & HUMAN RESOURCES

Address :
 STUART DESIGN GROUP
 ANDREW STUART

SDG JOB # : 6425A0309
 *** PA # : 1168 - EXPIRE : 2009-04-24 ***

Project Name : LD090125

Distributor : MONTEL

View : ELEVATION VIEW

Room : #1

MoDraw User : idaignault

Printed : 2009-03-30

Last Modified : 2009-03-30

Expiration : 2009-04-29

MoDraw Version : 3.6.35

Page : 2/6

MONTEL
 The Intelligent Use of Space

www.monitel.com
 System@monitel.com
 1-877-935-0235 (USA)
 1-800-935-0235 (CAN)

ONLY DRAWINGS BEARING THE NUMBER OF THE ACKNOWLEDGEMENT OF ORDER ARE BINDING FOR THE EXECUTION

This drawing contains proprietary and confidential information. Duplication, reproduction or use of this document or its content in any form other than as expressly permitted by Montel Inc. are strictly prohibited. ALL DIMENSIONS HAVE TO BE VERIFIED WITH ACTUAL SITE DIMENSIONS.

FRONT VIEW
WITHOUT PANEL

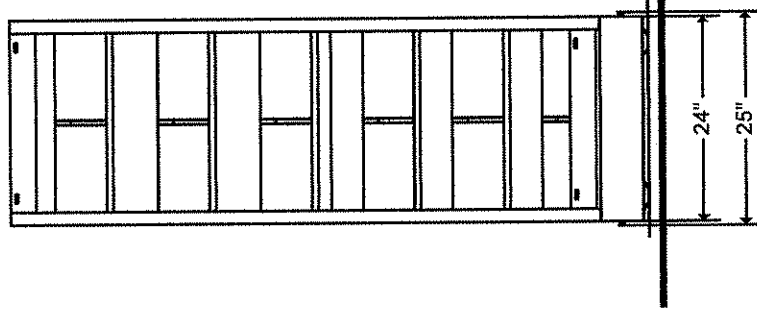

LEFT SIDE VIEW (1)

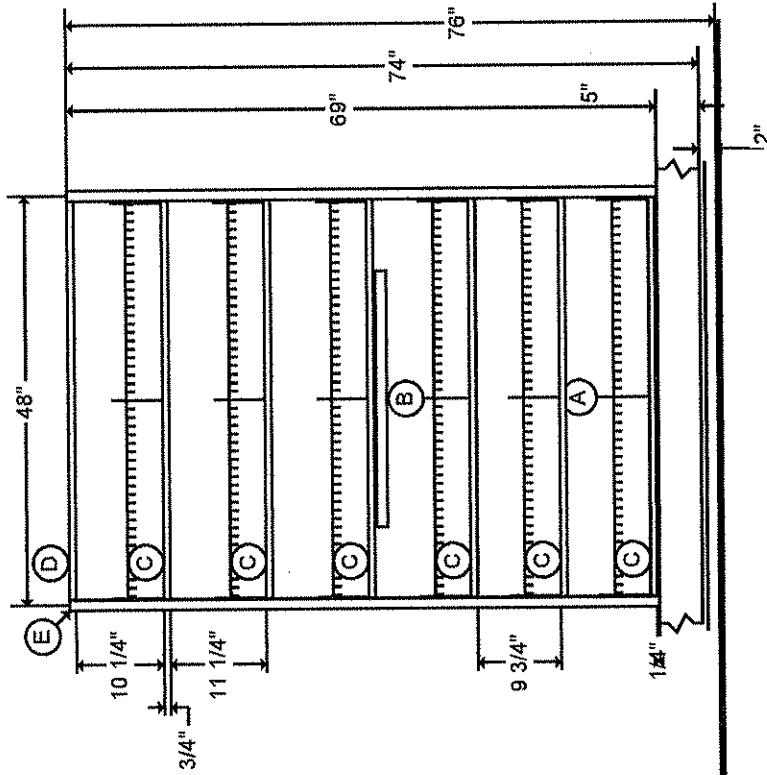

Legend

- A DIVIDER
- B QS.BRES3015/48 REFERENCE SHELF
- C QSC4824DFA SLOTTED BOX SHELF
- D QST4824SHA TOP SHELF
- E UPRIGHT CLOSING PARTITIONS

LEGEND

- SINGLE FACE FIXED ON FLOOR
- DOUBLE FACE FIXED ON FLOOR
- MOBILE SINGLE FACE SHELVING
- FIXED SINGLE FACE SHELVING
- FIXED DOUBLE FACE SHELVING
- MOBILE SINGLE FACE SHELVING
- MOBILE DOUBLE FACE SHELVING
- DOUBLE FACE FULLBACK
- SWAY BRACE
- HANDLE (FOR MECHANICAL SYSTEM)

Project Description : WEST VIRGINIA HEALTH & HUMAN RESOURCES		Address : STUART DESIGN GROUP ANDREW STUART SDG JOB # : 6425A0309 *** PA # : 1168 - EXPIRE : 2009-04-24 ***		Project Name : LD090125	
Distributor : MONTEL		ELEVATION VIEW		Room : #1	
View :		* Comments : SYSTEM #A - DFM 1-1 (FULL DEPTH)		ModDraw User : Idaigneault	
		ONLY DRAWINGS BEARING THE NUMBER OF THE ACKNOWLEDGMENT OF ORDER ARE BINDING FOR THE EXECUTION		Printed : 2009-03-30	
www.montel.com system@montel.com 1-877-935-0236 (USA) 1-800-935-0235 (CAN)		* Comments : SYSTEM #A - DFM 1-1 (FULL DEPTH)		Last Modified : 2009-03-30	
This drawing contains proprietary and confidential information. Duplication, reproduction or use of this document or its content in any form other than as expressly permitted by Montel Inc. are strictly prohibited. ALL DIMENSIONS HAVE TO BE VERIFIED WITH ACTUAL SITE DIMENSIONS.		* Comments : SYSTEM #A - DFM 1-1 (FULL DEPTH)		Expiration : 2009-04-29	
This drawing contains proprietary and confidential information. Duplication, reproduction or use of this document or its content in any form other than as expressly permitted by Montel Inc. are strictly prohibited. ALL DIMENSIONS HAVE TO BE VERIFIED WITH ACTUAL SITE DIMENSIONS.		* Comments : SYSTEM #A - DFM 1-1 (FULL DEPTH)		ModDraw Version : 3.6.35	
This drawing contains proprietary and confidential information. Duplication, reproduction or use of this document or its content in any form other than as expressly permitted by Montel Inc. are strictly prohibited. ALL DIMENSIONS HAVE TO BE VERIFIED WITH ACTUAL SITE DIMENSIONS.		* Comments : SYSTEM #A - DFM 1-1 (FULL DEPTH)		Page : 4/6	

THE AMERICAN INSTITUTE OF ARCHITECTS



AIA Document A310

Bid Bond

BOND # 70691438

KNOW ALL MEN BY THESE PRESENTS, that we

STUART DESIGN GROUP, INC.

P.O. BOX 710 GREENSBURG, PA 15601

(Here insert full name, and address or legal title of Contractor)

as Principal, hereinafter called the Principal, and

WESTERN SURETY CO.

101 SOUTH PHILLIPS AVE SIOUX FALLS, SD 57192

a corporation duly organized under the laws of the State of SOUTH DAKOTA as Surety, hereinafter called the Surety, are held and firmly bound unto STATE OF WEST VIRGINIA

2019 WASHINGTON STREET EAST CHARELSTON, WV 25305

(Here insert full name, and address or legal title of Owner)

as Obligee, hereinafter called the Obligee, in the sum of **Ten Percent of Amount Bid**-----Dollars (\$ 10%),

for the payment of which sum well and truly to be made, the said Principal and the said Surety, bind ourselves, our heirs, executors, administrators, successors and assigns, jointly and severally, firmly by these presents.

WHEREAS, the Principal has submitted a bid for **HIGH DENSITY FILING SYSTEM, WHITEHALL, WV**

(Here insert full name, address and description of project)

NOW, THEREFORE, if the Obligee shall accept the bid of the Principal and the Principal shall enter into a Contract with the Obligee in accordance with the terms of such bid and give such bond or bonds as may be specified in the bidding or Contract Documents with good and sufficient surety for the faithful performance of such Contract and for the prompt payment of labor and material furnished in the prosecution thereof, or in the event of the failure of the Principal to enter such Contract and give such bond or bonds, if the Principal shall pay to the Obligee the difference not to exceed the penalty hereof between the amount specified in said bid and such larger amount for which the Obligee may in good faith contract with another party to perform the Work covered by said bid then this obligation shall be null and void, otherwise to remain in full force and effect.

Signed and sealed this 2nd day of April, 2009

Britten Bichard
(Witness)

STUART DESIGN GROUP, INC.
(Principal) (Seal)
(Title) President

James C. Kelly
(Witness)

WESTERN SURETY CO.
(Surety) (Seal)
(Attorney-in-Fact) JAMES C. CARLINS

POWER OF ATTORNEY

(Irrevocable)

No. SP-

22771489

Know All Men by These Presents:

That this Power of Attorney is not valid or in effect unless attached to the bond which it authorizes executed, but may be detached by the approving officer if desired. That Western Surety Company, a corporation, does hereby make, constitute and appoint the following

FIVE 5 authorized individuals:

AUTHORIZED INDIVIDUALS	AUTHORIZED INDIVIDUALS
ANTHONY P LEKSE JAMES C CARLINS RICHARD J TAYLOR	CHRISTOPHER J RUCK LINDA L CARROLL
VOID-VOID-VOID	VOID-VOID-VOID
VOID-VOID-VOID	VOID-VOID-VOID
VOID-VOID-VOID	VOID-VOID-VOID
VOID-VOID-VOID	VOID-VOID-VOID

in the City of PITTSBURGH, State of PENNSYLVANIA, with limited authority, its true and lawful Attorney(s) in fact with full power and authority hereby conferred, to sign, execute, acknowledge and deliver for and on its behalf as Surety, the following described bond:

BID, PERFORMANCE, AND/OR PAYMENT BOND, IN ADDITION THE RELATED TRANSACTIONS SUCH AS CONSENTS OF SURETY, RIDERS, AND LETTERS OF INTENT, MAINTENANCE AND WARRANTY BONDS, PROVIDING THE BOND PENALTY DOES NOT EXCEED FIVE HUNDRED THOUSAND AND NO/100 DOLLARS (**500,000.00).**

The acknowledgment and execution of such bond by the said Attorney in Fact shall be as binding upon this Company as if such bond had been executed and acknowledged by the regularly elected officers of this Company.

All authority hereby conferred shall expire and terminate, without notice, unless used before midnight of

JANUARY 31 2014, but until such time shall be irrevocable and in full force and effect.

WESTERN SURETY COMPANY further certifies that the following is a true and exact copy of Section 7 of the By-Laws of Western Surety Company, duly adopted and now in force, to-wit: "Section 7. All bonds, policies, undertakings, Powers of Attorney, or other obligations of the corporation shall be executed in the corporate name of the Company by the President, Secretary, any Assistant Secretary, Treasurer, or any Vice President, or by such other officers as the Board of Directors may authorize. The President, any Vice President, Secretary, any Assistant Secretary, or the Treasurer may appoint Attorneys in Fact or Agents who shall have authority to issue bonds, policies, or undertakings in the name of the Company. The corporate seal is not necessary for the validity of any bonds, policies, undertakings, Powers of Attorney or other obligations of the corporation. The signature of any such officer and the corporate seal may be printed by facsimile."

The penal amount of the bond herein described may be increased if there is attached to this Power, written authority so authorizing in the form of an endorsement, letter or telegram signed by the Underwriting Manager, Underwriting Consultant, Underwriting Specialist, Underwriter, President, Vice President, Assistant Vice President, Treasurer, Secretary or Assistant Secretary of Western Surety Company specifically authorizing said increase.

IN WITNESS WHEREOF, Western Surety Company has caused these presents to be executed by its Senior Vice President with its corporate seal affixed this 11th day of December, 2006.

WESTERN SURETY COMPANY

STATE OF SOUTH DAKOTA }
COUNTY OF MINNEHAHA } ss.

By Paul T. Bruflat
Senior Vice President

On this 11th day of December, in the year 2006, before me, a Notary Public, personally appeared Paul T. Bruflat, who being by me duly sworn, acknowledged that he signed the above Power of Attorney as the aforesaid officer of WESTERN SURETY COMPANY and acknowledged said instrument to be the voluntary act and deed of said corporation.



D. Krell

Notary Public, South Dakota

My Commission Expires November 30, 2012

I, the undersigned officer of Western Surety Company, a stock corporation of the State of South Dakota, do hereby certify that the attached Power of Attorney is in full force and effect and is irrevocable; and furthermore, that Section 7 of the By-Laws of the company as set forth in the Power of Attorney, is now in force.

In testimony whereof, I have hereunto set my hand and the seal of Western Surety Company this 2nd day of April, 2009

WESTERN SURETY COMPANY

***IMPORTANT: This date must be filled in before it is attached to the bond and it must be the same date as the bond.**

By Paul T. Bruflat
Senior Vice President

Form 749-12-2006

NOTICE: This border must be BLUE. If it is not BLUE, this is not a certified copy. —————>

**GENERAL TERMS & CONDITIONS
REQUEST FOR QUOTATION (RFQ) AND REQUEST FOR PROPOSAL (RFP)**

1. Awards will be made in the best interest of the State of West Virginia.
2. The State may accept or reject in part, or in whole, any bid.
3. All quotations are governed by the *West Virginia Code* and the *Legislative Rules* of the Purchasing Division.
4. Prior to any award, the apparent successful vendor must be properly registered with the Purchasing Division and have paid the required \$125 fee.
5. All services performed or goods delivered under State Purchase Order/Contracts are to be continued for the term of the Purchase Order/Contracts, contingent upon funds being appropriated by the Legislature or otherwise being made available. In the event funds are not appropriated or otherwise available for these services or goods, this Purchase Order/Contract becomes void and of no effect after June 30.
6. Payment may only be made after the delivery and acceptance of goods or services.
7. Interest may be paid for late payment in accordance with the *West Virginia Code*.
8. Vendor preference will be granted upon written request in accordance with the *West Virginia Code*.
9. The State of West Virginia is exempt from federal and state taxes and will not pay or reimburse such taxes.
10. The Director of Purchasing may cancel any Purchase Order/Contract upon 30 days written notice to the seller.
11. The laws of the State of West Virginia and the *Legislative Rules* of the Purchasing Division shall govern all rights and duties under the Contract, including without limitation the validity of this Purchase Order/Contract.
12. Any reference to automatic renewal is hereby deleted. The Contract may be renewed only upon mutual written agreement of the parties.
13. **BANKRUPTCY:** In the event the vendor/contractor files for bankruptcy protection, this Contract may be deemed null and void, and terminated without further order.
14. **HIPAA BUSINESS ASSOCIATE ADDENDUM:** The West Virginia State Government HIPAA Business Associate Addendum (BAA), approved by the Attorney General, and available online at the Purchasing Division's web site (<http://www.state.wv.us/admin/purchase/vrc/hipaa.htm>) is hereby made part of the agreement. Provided that, the Agency meets the definition of a Cover Entity (45 CFR §160.103) and will be disclosing Protected Health Information (45 CFR §160.103) to the vendor.
15. **WEST VIRGINIA ALCOHOL & DRUG-FREE WORKPLACE ACT:** If this Contract constitutes a public improvement construction contract as set forth in Article 1D, Chapter 21 of the West Virginia Code ("The West Virginia Alcohol and Drug-Free Workplace Act"), then the following language shall hereby become part of this Contract: "The contractor and its subcontractors shall implement and maintain a written drug-free workplace policy in compliance with the West Virginia Alcohol and Drug-Free Workplace Act, as set forth in Article 1D, Chapter 21 of the West Virginia Code. The contractor and its subcontractors shall provide a sworn statement in writing, under the penalties of perjury, that they maintain a valid drug-free work place policy in compliance with the West Virginia and Drug-Free Workplace Act. It is understood and agreed that this Contract shall be cancelled by the awarding authority if the Contractor: 1) Fails to implement its drug-free workplace policy; 2) Fails to provide information regarding implementation of the contractor's drug-free workplace policy at the request of the public authority; or 3) Provides to the public authority false information regarding the contractor's drug-free workplace policy."

INSTRUCTIONS TO BIDDERS

1. Use the quotation forms provided by the Purchasing Division.
2. **SPECIFICATIONS:** Items offered must be in compliance with the specifications. Any deviation from the specifications must be clearly indicated by the bidder. Alternates offered by the bidder as **EQUAL** to the specifications must be clearly defined. A bidder offering an alternate should attach complete specifications and literature to the bid. The Purchasing Division may waive minor deviations to specifications.
3. Complete all sections of the quotation form.
4. Unit prices shall prevail in case of discrepancy.
5. All quotations are considered F.O.B. destination unless alternate shipping terms are clearly identified in the quotation.
6. **BID SUBMISSION:** All quotations must be delivered by the bidder to the office listed below prior to the date and time of the bid opening. Failure of the bidder to deliver the quotations on time will result in bid disqualifications: Department of Administration, Purchasing Division, 2019 Washington Street East, P.O. Box 50130, Charleston, WV 25305-0130

Stuart Design Group

BCF 90128

04-02-09

Mobilex®

High-Density Mechanical Mobile Storage Systems

storage optimized



MONTEL®
The Intelligent Use of Space



recall

recall

recall

recall

recall

recall

Reliability

Flexibility

Rigidity

Safety

Performance Smooth Movement

Durability Aesthetics

Efficiency Ease of Operation

What are your Storage Solutions?

For today's modern commercial interiors and the built workspace environment, Montel understands the importance of offering cost-effective innovative storage solutions. For your unique storage needs, the Mobilex® high-density mechanical mobile storage system offers the performance solution required for greater evolving storage capacity.

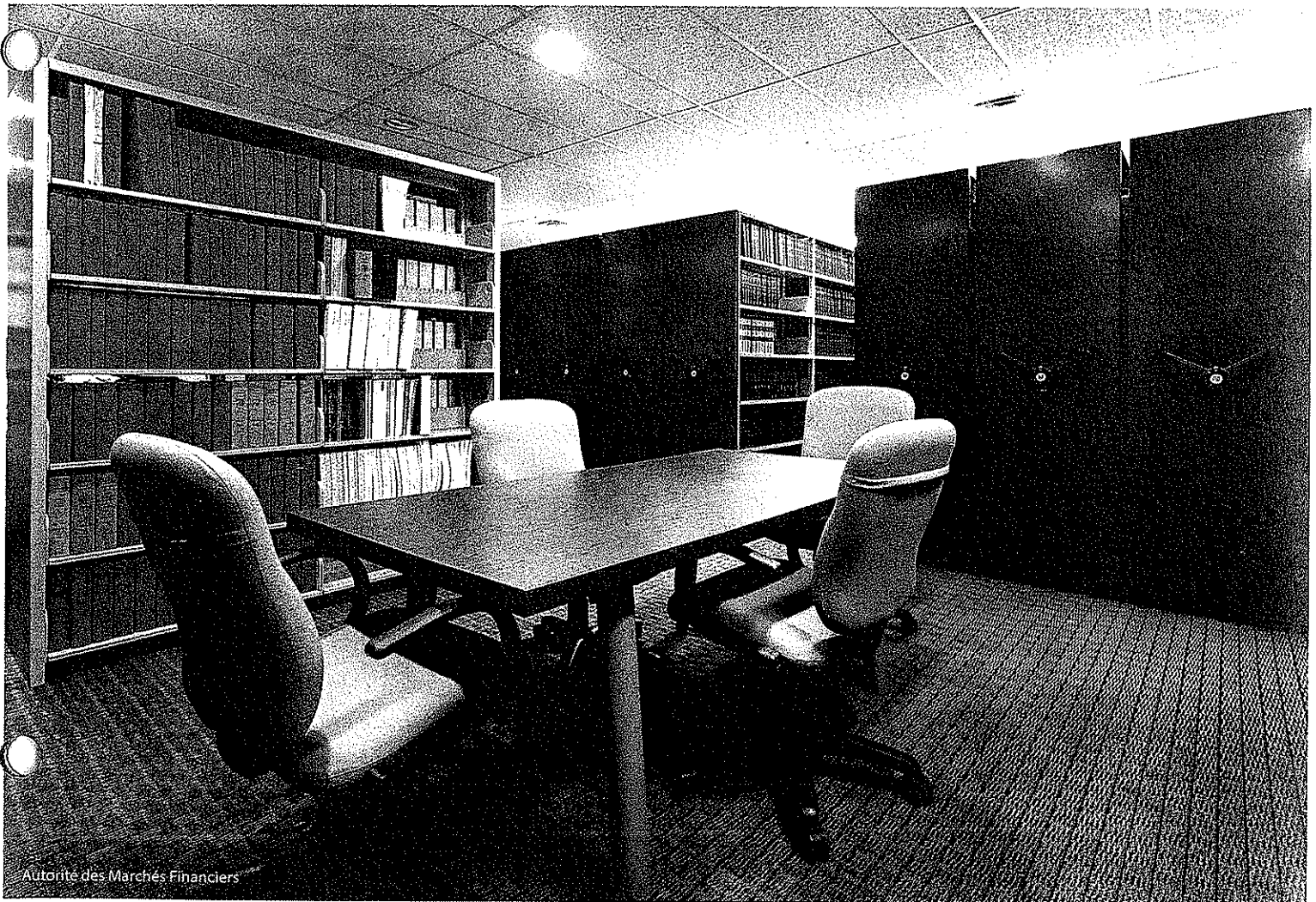

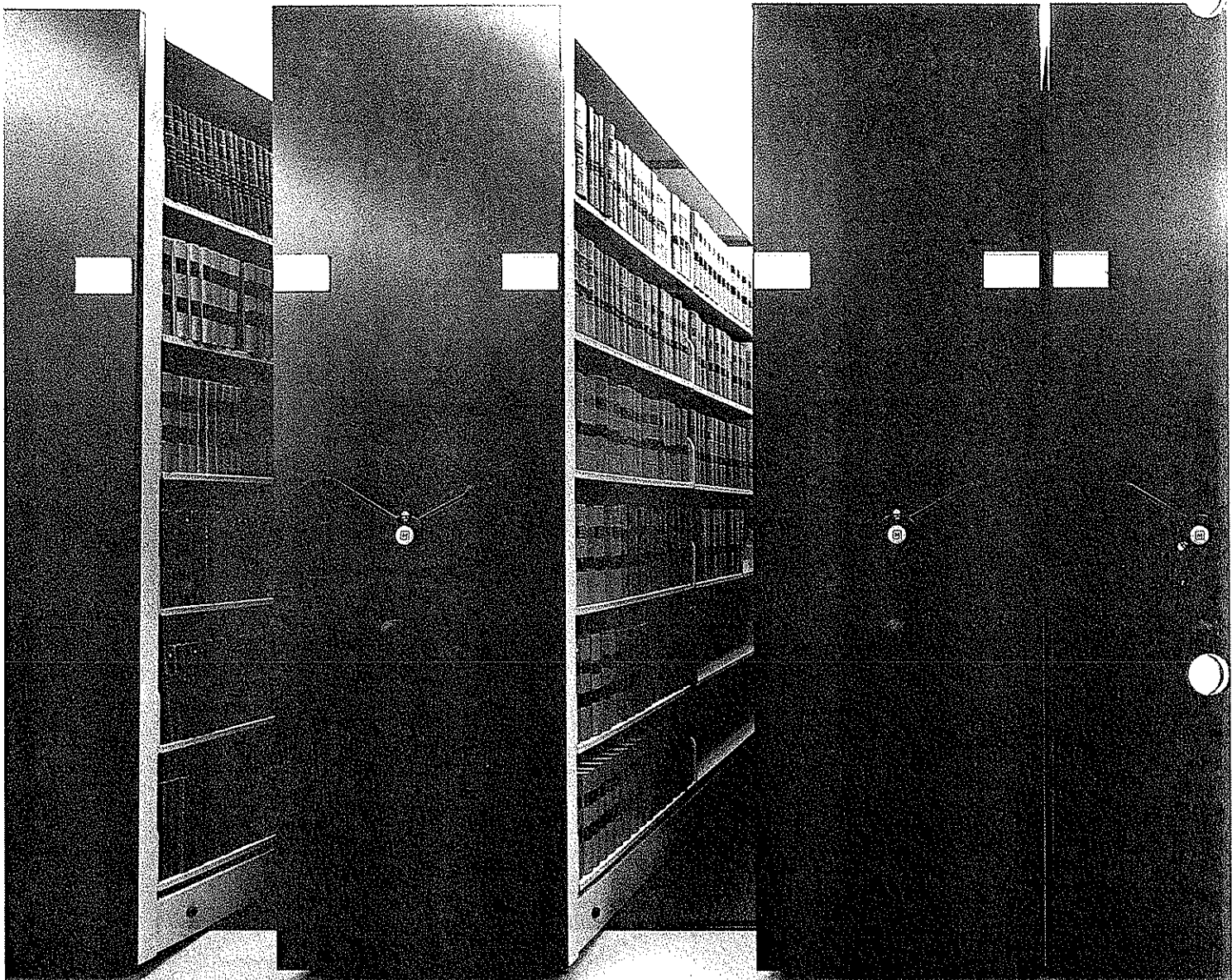

Leger-Robic Richard, L.L.P.

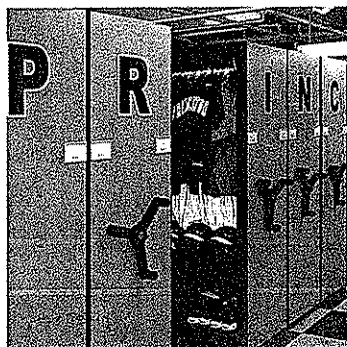

Princeton University Athletic Department

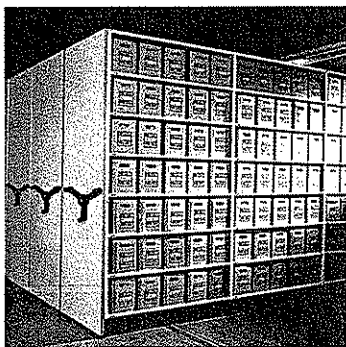

National Archives of Canada

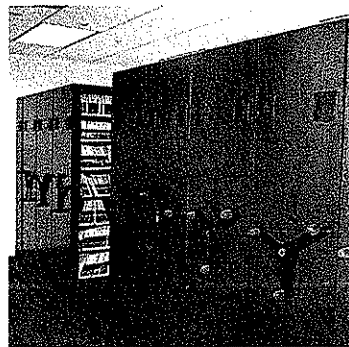

US Department of Homeland Security

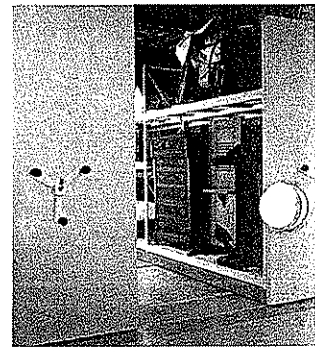

Charlevoix Museum

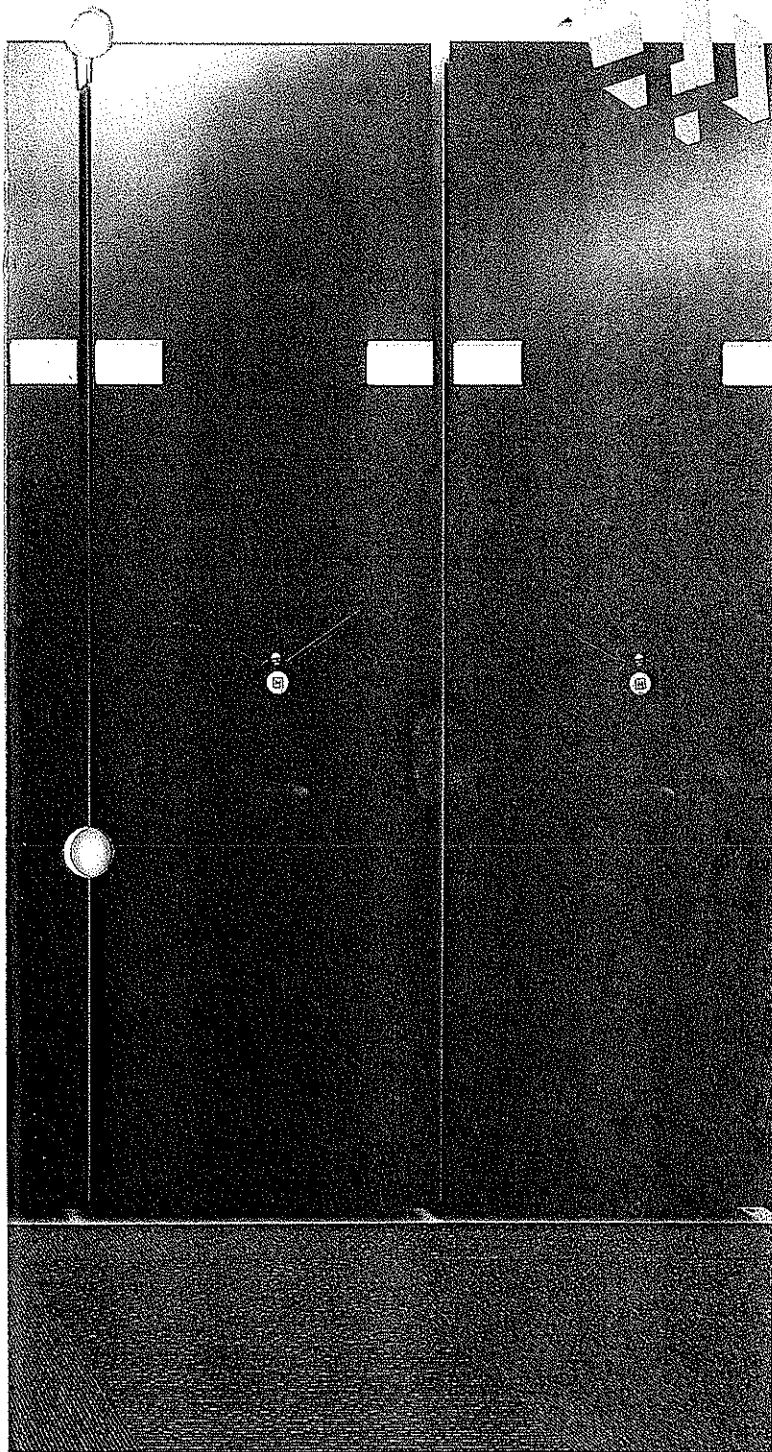

Building your Mobilex® System

The Mobilex® is designed to accommodate several Montel shelving systems: 4-Post (SmartShelf), Cantilever (Aetnastak), Case-Type (Cabinet Style) and semi-industrial Long Span Shelving (4D Wide Span).

The shelving systems offer a wide variety of accessories such as reference shelves, multimedia drawers, sliding shelves, specialized shelving and drawers and much more.

Infinite Storage Possibilities

Versatility and functionality. The Mobilex® offers endless storage solutions for specific storage needs: archives, artifacts, athletic equipment, blue prints, books, boxes, bulk storage, cabinets, files, film cans, linens, media, office supplies, pieces and parts, police evidence, records, skis, specimens, tapes, tools, video tapes, weapons, x-rays, etc.

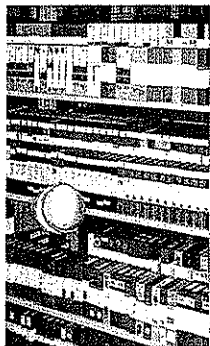

WGBH



Laval University Hospital Center



Environmental Sustainability

Recognizing the importance of manufacturing upscale products that meet and exceed environmental standards. Focusing on green-building initiatives that contribute to a more sustainable workspace environment. The Mobilex® was developed to comply and exceed environmental standards and provide a long useful life. More specifically, the Mobilex® high-density storage system:

- Conserves space
- Reduces operating costs
- Improves sustainable workspace environment
- Enhances building and organizational marketability
- Potentially increased employee productivity and satisfaction

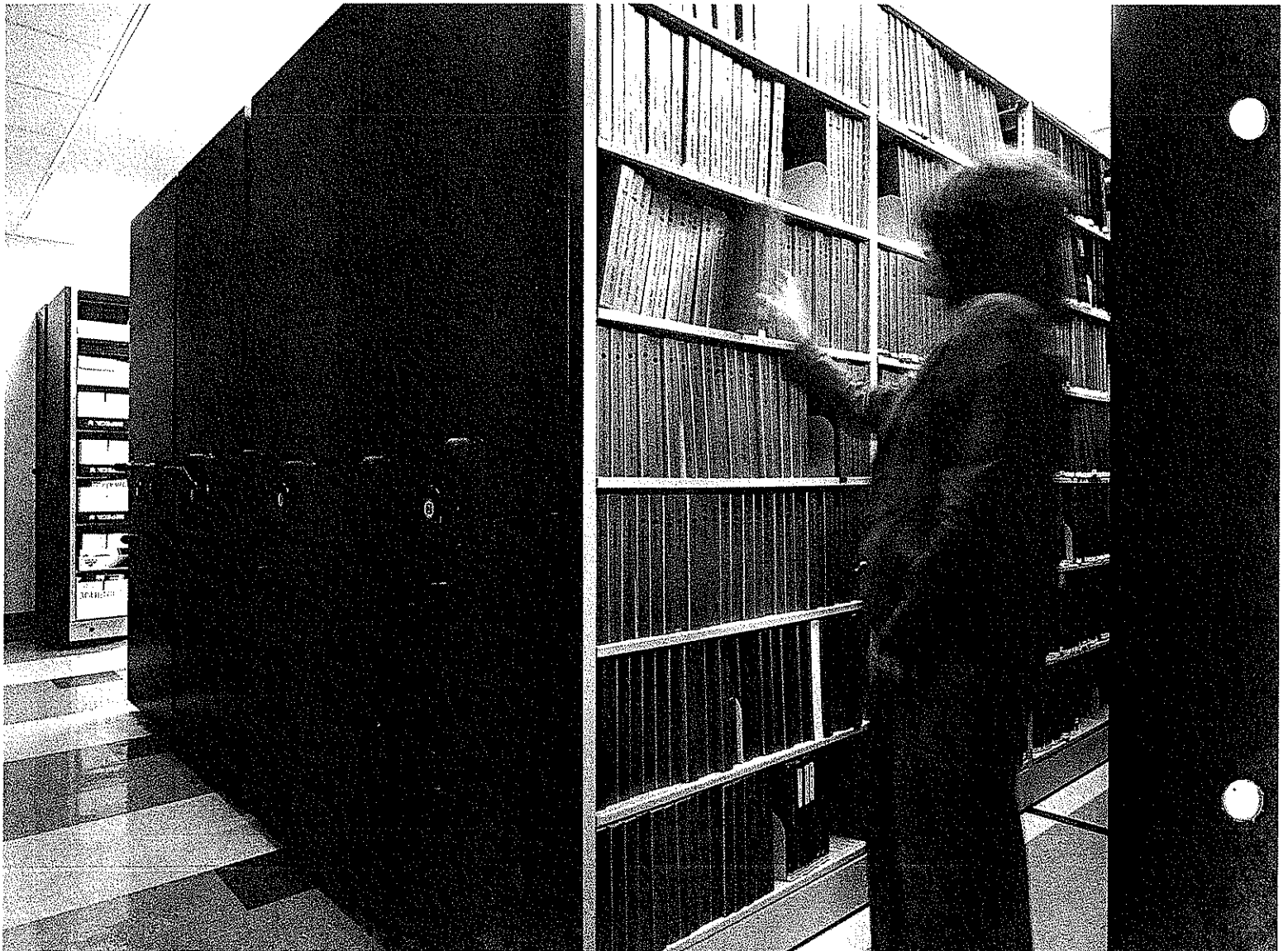

Design Features

- Aluminium Sub-Rail and Steel Rail
- Built-in Anti-Tip into Aluminium Sub-Rail
- Two Anti-Slip Grooves
- Two-Piece Rail
- Fully-Grouted Aluminium Sub-Rail
- Spring-Pin Rail Connector
- Spherically-Designed, Double-Flanged, Precision-Machined, Hardened Steel Load Wheels
- Flat, Precision-Machined, Hardened Steel Drive Wheels
- 5-inch Diameter, Precision-Machined Steel Wheels
- Full-Length Driving Shaft
- Hollow Tube Drive Shaft
- Aeronautic Rivets
- Carriage-Shelving Color Match (Optional)
- Aluminum End Panel Extrusion (Optional)
- Dual Access Control System (Optional)
- Adjustable Chain Tensioner (Optional)
- Ergonomic Three-Spoke Zinc Handle
- Soft-Touch Ergo Grip

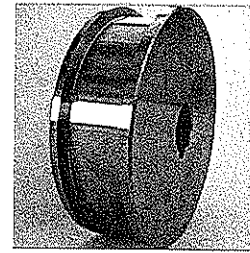

5-inch Steel Wheel

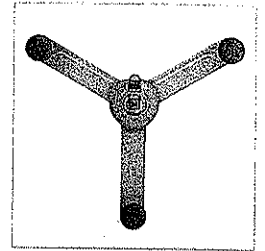

Handle

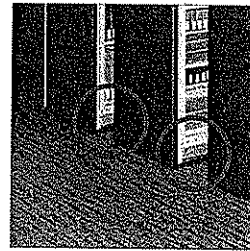

Aisle Mechanical Safety Brake

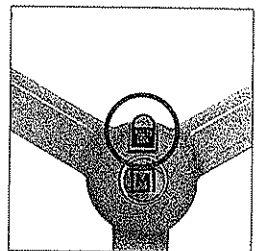

Locking Pin

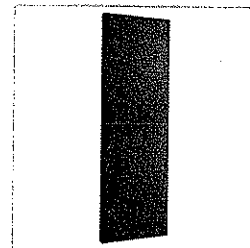

Front Panel



Pull-out Reference Shelf

Safety Features

- Aisle Mechanical Safety Brake
- Locking Pin
- High Visibility Reflective Strip

Aesthetics

For the complete selection of colors, handles and panels, please refer to the Color Chart and the Fashion Forward brochure.

Warranty

Please refer to www.montel.com for additional information.

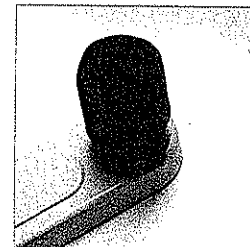

Ergo Grip



Accessories

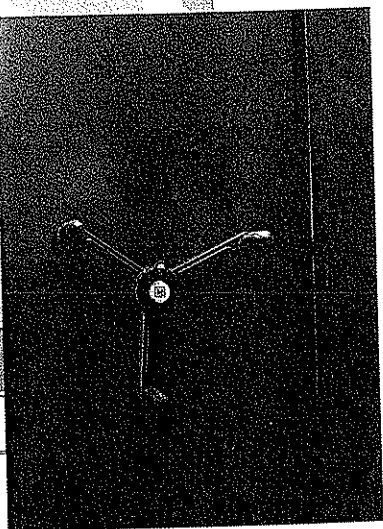

A Word about our Company

Established in 1924, Montel Inc. is the pioneer of high-density mobile shelving storage system solutions in North America. Manufacturer of products for corporate, institutional, library, museum, government, healthcare, military, industrial and retail applications, Montel's achievements include some of the most prestigious projects in North America and around the world. The company serves clients through a network of Authorized Distributors throughout North America, Latin America, Europe, Africa and the Middle East.

For more information about our products and services or to see a list of Distributors, please visit us at www.montel.com or call 877.935.0236.



MONTEL®

The Intelligent Use of Space

877-935-0236

system@montel.com - www.montel.com

