

**GENERAL TERMS & CONDITIONS
REQUEST FOR QUOTATION (RFQ) AND REQUEST FOR PROPOSAL (RFP)**

1. Awards will be made in the best interest of the State of West Virginia.
2. The State may accept or reject in part, or in whole, any bid.
3. All quotations are governed by the *West Virginia Code* and the *Legislative Rules* of the Purchasing Division.
4. Prior to any award, the apparent successful vendor must be properly registered with the Purchasing Division and have paid the required \$125 fee.
5. All services performed or goods delivered under State Purchase Order/Contracts are to be continued for the term of the Purchase Order/Contracts, contingent upon funds being appropriated by the Legislature or otherwise being made available. In the event funds are not appropriated or otherwise available for these services or goods, this Purchase Order/Contract becomes void and of no effect after June 30.
6. Payment may only be made after the delivery and acceptance of goods or services.
7. Interest may be paid for late payment in accordance with the *West Virginia Code*.
8. Vendor preference will be granted upon written request in accordance with the *West Virginia Code*.
9. The State of West Virginia is exempt from federal and state taxes and will not pay or reimburse such taxes.
10. The Director of Purchasing may cancel any Purchase Order/Contract upon 30 days written notice to the seller.
11. The laws of the State of West Virginia and the *Legislative Rules* of the Purchasing Division shall govern all rights and duties under the Contract, including without limitation the validity of this Purchase Order/Contract.
12. Any reference to automatic renewal is hereby deleted. The Contract may be renewed only upon mutual written agreement of the parties.
13. **BANKRUPTCY:** In the event the vendor/contractor files for bankruptcy protection, this Contract may be deemed null and void, and terminated without further order.
14. **HIPAA BUSINESS ASSOCIATE ADDENDUM:** The West Virginia State Government HIPAA Business Associate Addendum (BAA), approved by the Attorney General, and available online at the Purchasing Division's web site (<http://www.state.wv.us/admin/purchase/vrc/hipaa.htm>) is hereby made part of the agreement. Provided that, the Agency meets the definition of a Cover Entity (45 CFR §160.103) and will be disclosing Protected Health Information (45 CFR §160.103) to the vendor.
15. **WEST VIRGINIA ALCOHOL & DRUG-FREE WORKPLACE ACT:** If this Contract constitutes a public improvement construction contract as set forth in Article 1D, Chapter 21 of the West Virginia Code ("The West Virginia Alcohol and Drug-Free Workplace Act"), then the following language shall hereby become part of this Contract: "The contractor and its subcontractors shall implement and maintain a written drug-free workplace policy in compliance with the West Virginia Alcohol and Drug-Free Workplace Act, as set forth in Article 1D, Chapter 21 of the West Virginia Code. The contractor and its subcontractors shall provide a sworn statement in writing, under the penalties of perjury, that they maintain a valid drug-free work place policy in compliance with the West Virginia and Drug-Free Workplace Act. It is understood and agreed that this Contract shall be cancelled by the awarding authority if the Contractor: 1) Fails to implement its drug-free workplace policy; 2) Fails to provide information regarding implementation of the contractor's drug-free workplace policy at the request of the public authority; or 3) Provides to the public authority false information regarding the contractor's drug-free workplace policy."

INSTRUCTIONS TO BIDDERS

1. Use the quotation forms provided by the Purchasing Division.
2. **SPECIFICATIONS:** Items offered must be in compliance with the specifications. Any deviation from the specifications must be clearly indicated by the bidder. Alternates offered by the bidder as **EQUAL** to the specifications must be clearly defined. A bidder offering an alternate should attach complete specifications and literature to the bid. The Purchasing Division may waive minor deviations to specifications.
3. Complete all sections of the quotation form.
4. Unit prices shall prevail in case of discrepancy.
5. All quotations are considered F.O.B. destination unless alternate shipping terms are clearly identified in the quotation.
6. **BID SUBMISSION:** All quotations must be delivered by the bidder to the office listed below prior to the date and time of the bid opening. Failure of the bidder to deliver the quotations on time will result in bid disqualifications: Department of Administration, Purchasing Division, 2019 Washington Street East, P.O. Box 50130, Charleston, WV 25305-0130



State of West Virginia
 Department of Administration
 Purchasing Division
 2019 Washington Street East
 Post Office Box 50130
 Charleston, WV 25305-0130

Request for Quotation

RFQ NUMBER
ABC64

PAGE
2

ADDRESS CORRESPONDENCE TO ATTENTION OF:
SHELLY MURRAY 304-558-8801

RFQ COPY
 TYPE NAME/ADDRESS HERE

V
E
N
D
O
R

S
H
I
P
T
O

ALCOHOL BEVERAGE CONTROL
 COMMISSION
 322 70TH STREET, S.E.

 CHARLESTON, WV
 25304-2900 558-2487

DATE PRINTED	TERMS OF SALE	SHIP VIA	F.O.B.	FREIGHT TERMS
12/11/2008				

BID OPENING DATE: 12/23/2008 BID OPENING TIME 01:30PM

LINE	QUANTITY	UOP	CAT NO	ITEM NUMBER	UNIT PRICE	AMOUNT
NO. 4					
NO. 5					
<p>I UNDERSTAND THAT FAILURE TO CONFIRM THE RECEIPT OF THE ADDENDUM(S) MAY BE CAUSE FOR REJECTION OF BIDS.</p> <p>VENDOR MUST CLEARLY UNDERSTAND THAT ANY VERBAL REPRESENTATION MADE OR ASSUMED TO BE MADE DURING ANY ORAL DISCUSSION HELD BETWEEN VENDOR'S REPRESENTATIVES AND ANY STATE PERSONNEL IS NOT BINDING. ONLY THE INFORMATION ISSUED IN WRITING AND ADDED TO THE SPECIFICATIONS BY AN OFFICIAL ADDENDUM IS BINDING.</p>						
				<p>..... SIGNATURE United Services Gr. COMPANY 12-19-08 DATE</p>		
<p>FOR MORE INFO VISIT OUR WEBSITE www.unitedservicesgr.com</p>						
<p>REV. 11/96</p> <p>----- END OF ADDENDUM NO. 1 -----</p>						

SEE REVERSE SIDE FOR TERMS AND CONDITIONS

SIGNATURE	TELEPHONE	DATE
TITLE	FEIN	ADDRESS CHANGES TO BE NOTED ABOVE

WHEN RESPONDING TO RFQ, INSERT NAME AND ADDRESS IN SPACE ABOVE LABELED 'VENDOR'



State of West Virginia
 Department of Administration
 Purchasing Division
 2019 Washington Street East
 Post Office Box 50130
 Charleston, WV 25305-0130

Request for Quotation

RFQ NUMBER: ABC64

PAGE: 1

ADDRESS CORRESPONDENCE TO ATTENTION OF:
 SHELLY MURRAY
 304-558-8801

RFQ COPY
 TYPE NAME/ADDRESS HERE

ALCOHOL BEVERAGE CONTROL
 COMMISSION
 322 70TH STREET, S.E.
 CHARLESTON, WV
 25304-2900 558-2487

DATE PRINTED	TERMS OF SALE	SHIP VIA	F.O.B.	FREIGHT TERMS
11/25/2008				

BID OPENING DATE: 12/23/2008 BID OPENING TIME 01:30PM

LINE	QUANTITY	UOP	QAT NO	ITEM NUMBER	UNIT PRICE	AMOUNT
0001	2	EA		560-75	19895.00	39790.00
<p>THE WV PURCHASING DIVISION, FOR THE AGENCY, THE WV ALCOHOL BEVERAGE CONTROL ADMINISTRATION, IS SOLICITING BIDS TO PROVIDE THE AGENCY WITH TWO (2) LPG POWERED FORK LIFT TRUCKS.</p> <p>INQUIRES: WRITTEN QUESTIONS SHALL BE ACCEPTED THROUGH CLOSE OF BUSINESS ON 12/09/2008. QUESTIONS MAY BE SENT VIA USPS, FAX, COURIER, OR EMAIL. IN ORDER TO ASSURE NO VENDOR RECEIVES AN UNFAIR ADVANTAGE, NO SUBSTANTIVE QUESTIONS WILL BE ANSWERED DRALLY. IF POSSIBLE, EMAIL QUESTIONS ARE PREFERRED. ADDRESS INQUIRES TO:</p> <p>SHELLY MURRAY DEPARTMENT OF ADMINISTRATION PURCHASING DIVISION 2019 WASHINGTON STREET, EAST CHARLESTON, WV 25311 FAX: 304-558-4115 EMAIL: SHELLY.L.MURRAY@WV.GOV</p> <p>FOR MORE INFO VISIT OUR WEBSITE www.unifedservicesgp.com</p> <p>RECEIVED 2008 DEC 22 A 10:03 PURCHASING DIVISION STATE OF WV</p> <p>CANCELLATION: THE DIRECTOR OF PURCHASING RESERVES THE RIGHT TO CANCEL THIS CONTRACT IMMEDIATELY UPON WRITTEN NOTICE TO THE VENDOR IF THE COMMODITIES AND/OR SERVICES SUPPLIED ARE OF AN INFERIOR QUALITY OR DO NOT CONFORM TO THE SPECIFICATIONS OF THE BID AND CONTRACT HEREIN.</p>						

SEE REVERSE SIDE FOR TERMS AND CONDITIONS

SIGNATURE	TELEPHONE	DATE
TITLE	FEIN	ADDRESS CHANGES TO BE NOTED ABOVE

WHEN RESPONDING TO RFQ, INSERT NAME AND ADDRESS IN SPACE ABOVE LABELED 'VENDOR'



State of West Virginia
 Department of Administration
 Purchasing Division
 2019 Washington Street East
 Post Office Box 50130
 Charleston, WV 25305-0130

Request for Quotation

RFQ NUMBER
ABC64

PAGE
2

ADDRESS CORRESPONDENCE TO ATTENTION OF
**SHELLY MURRAY
 304-558-8801**

VENDOR

RFQ COPY
 TYPE NAME/ADDRESS HERE

SHIP TO

**ALCOHOL BEVERAGE CONTROL
 COMMISSION
 322 70TH STREET, S.E.
 CHARLESTON, WV
 25304-2900 558-2487**

DATE PRINTED	TERMS OF SALE	SHIP VIA	FOB	FREIGHT TERMS
11/25/2008				

BID OPENING DATE: **12/23/2008** BID OPENING TIME **01:30PM**

LINE	QUANTITY	UOP	CAT. NO.	ITEM NUMBER	UNIT PRICE	AMOUNT
<p>BANKRUPTCY: IN THE EVENT THE VENDOR/CONTRACTOR FILES FOR BANKRUPTCY PROTECTION, THIS CONTRACT IS AUTOMATICALLY NULL AND VOID, AND IS TERMINATED WITHOUT FURTHER ORDER.</p> <p>THE TERMS AND CONDITIONS CONTAINED IN THIS CONTRACT SHALL SUPERSEDE ANY AND ALL SUBSEQUENT TERMS AND CONDITIONS WHICH MAY APPEAR ON ANY ATTACHED PRINTED DOCUMENTS SUCH AS PRICE LISTS, ORDER FORMS, SALES AGREEMENTS OR MAINTENANCE AGREEMENTS, INCLUDING ANY ELECTRONIC MEDIUM SUCH AS CD-ROM.</p> <p style="text-align: center;">NOTICE</p> <p>A SIGNED BID MUST BE SUBMITTED TO:</p> <p style="padding-left: 40px;">DEPARTMENT OF ADMINISTRATION PURCHASING DIVISION BUILDING 15 2019 WASHINGTON STREET, EAST CHARLESTON, WV 25305-0130</p> <p>THE BID SHOULD CONTAIN THIS INFORMATION ON THE FACE OF THE ENVELOPE OR THE BID MAY NOT BE CONSIDERED:</p> <p>SEALED BID</p> <p>BUYER: SHELLY MURRAY / FILE 31</p> <p>RFQ. NO.: ABC64</p> <p>BID OPENING DATE: 12/23/2008</p>						

SEE REVERSE SIDE FOR TERMS AND CONDITIONS

SIGNATURE	TELEPHONE	DATE
TITLE	FEIN	ADDRESS CHANGES TO BE NOTED ABOVE

WHEN RESPONDING TO RFQ, INSERT NAME AND ADDRESS IN SPACE ABOVE LABELED 'VENDOR'



State of West Virginia
 Department of Administration
 Purchasing Division
 2019 Washington Street East
 Post Office Box 50130
 Charleston, WV 25305-0130

Request for Quotation

RFQ NUMBER
ABC64

PAGE
3

ADDRESS CORRESPONDENCE TO ATTENTION OF
**SHELLY MURRAY
 304-558-8801**

RFQ COPY
TYPE NAME/ADDRESS HERE

**ALCOHOL BEVERAGE CONTROL
 COMMISSION
 322 70TH STREET, S.E.
 CHARLESTON, WV
 25304-2900 558-2487**

DATE PRINTED	TERMS OF SALE	SHIP VIA	F.O.B.	FREIGHT TERMS
11/25/2008				

BID OPENING DATE: **12/23/2008** BID OPENING TIME **01:30PM**

LINE	QUANTITY	UOP	GAT. NO.	ITEM NUMBER	UNIT PRICE	AMOUNT
<p>BID OPENING TIME: 1:30 PM</p> <p>PLEASE PROVIDE A FAX NUMBER IN CASE IT IS NECESSARY TO CONTACT YOU REGARDING YOUR BID:</p> <p>-----</p> <p>CONTACT PERSON (PLEASE PRINT CLEARLY):</p> <p>-----</p> <p>***** THIS IS THE END OF RFQ ABC64 ***** TOTAL: <u>39,790.00</u></p> <p><i>- No Exceptions To Your Specifications</i> <i>- Local Parts and Service Available</i></p>						

SEE REVERSE SIDE FOR TERMS AND CONDITIONS

SIGNATURE	TELEPHONE	DATE
TITLE	FEIN	ADDRESS CHANGES TO BE NOTED ABOVE

WHEN RESPONDING TO RFQ, INSERT NAME AND ADDRESS IN SPACE ABOVE LABELED 'VENDOR'

STATE OF WEST VIRGINIA
Purchasing Division

PURCHASING AFFIDAVIT

VENDOR OWING A DEBT TO THE STATE:

West Virginia Code §5A-3-10a provides that: No contract or renewal of any contract may be awarded by the state or any of its political subdivisions to any vendor or prospective vendor when the vendor or prospective vendor or a related party to the vendor or prospective vendor is a debtor and the debt owed is an amount greater than one thousand dollars in the aggregate.

PUBLIC IMPROVEMENT CONTRACTS & DRUG-FREE WORKPLACE ACT:

West Virginia Code §21-1D-5 provides that: Any solicitation for a public improvement construction contract shall require each vendor that submits a bid for the work to submit at the same time an affidavit that the vendor has a written plan for a drug-free workplace policy in compliance with Article 1D, Chapter 21 of the West Virginia Code. A public improvement construction contract may not be awarded to a vendor who does not have a written plan for a drug-free workplace policy in compliance with Article 1D, Chapter 21 of the West Virginia Code and who has not submitted that plan to the appropriate contracting authority in timely fashion. For a vendor who is a subcontractor, compliance with Section 5, Article 1D, Chapter 21 of the West Virginia Code may take place before their work on the public improvement is begun.

ANTITRUST:

In submitting a bid to any agency for the state of West Virginia, the bidder offers and agrees that if the bid is accepted the bidder will convey, sell, assign or transfer to the state of West Virginia all rights, title and interest in and to all causes of action it may now or hereafter acquire under the antitrust laws of the United States and the state of West Virginia for price fixing and/or unreasonable restraints of trade relating to the particular commodities or services purchased or acquired by the state of West Virginia. Such assignment shall be made and become effective at the time the purchasing agency tenders the initial payment to the bidder.

I certify that this bid is made without prior understanding, agreement, or connection with any corporation, firm, limited liability company, partnership or person or entity submitting a bid for the same materials, supplies, equipment or services and is in all respects fair and without collusion or fraud. I further certify that I am authorized to sign the certification on behalf of the bidder or this bid.

LICENSING:

Vendors must be licensed and in good standing in accordance with any and all state and local laws and requirements by any state or local agency of West Virginia, including, but not limited to, the West Virginia Secretary of State's Office, the West Virginia Tax Department, West Virginia Insurance Commission, or any other state agencies or political subdivision. Furthermore, the vendor must provide all necessary releases to obtain information to enable the Director or spending unit to verify that the vendor is licensed and in good standing with the above entities.

CONFIDENTIALITY:

The vendor agrees that he or she will not disclose to anyone, directly or indirectly, any such personally identifiable information or other confidential information gained from the agency, unless the individual who is the subject of the information consents to the disclosure in writing or the disclosure is made pursuant to the agency's policies, procedures and rules. Vendors should visit www.state.wv.us/admin/purchase/privacy for the Notice of Agency Confidentiality Policies.

Under penalty of law for false swearing (*West Virginia Code* §61-5-3), it is hereby certified that the vendor acknowledges the information in this said affidavit and is in compliance with the requirements as stated.

Vendor's Name: United Services GP & WC

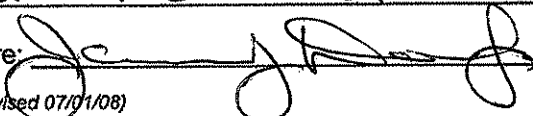
Authorized Signature:  Date: 12-19-08

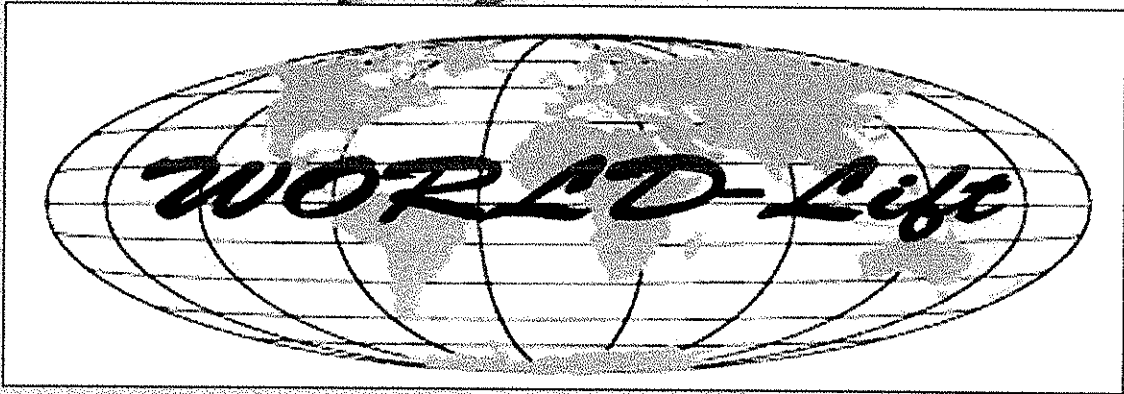

WFG40-50C

WORLD-LIFT FORKLIFTS

SPECIFICATIONS / FEATURES



CUSHION TIRE - WFG40-50C

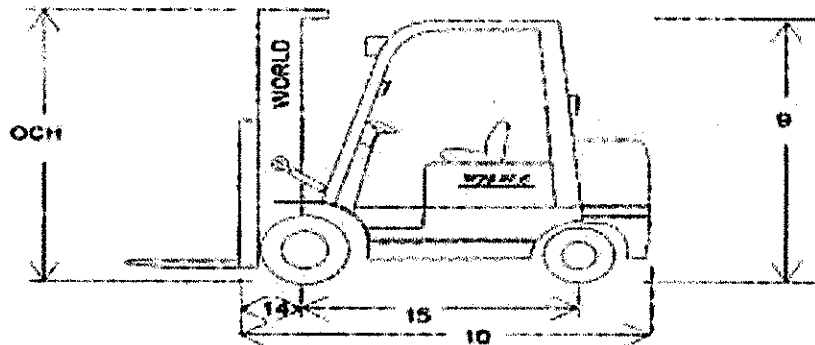
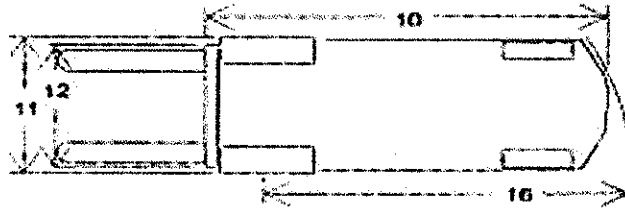

Mast Information

Type	Overall Collapsed Height	Maximum Fork Height	Mast Free Lift	Tilt Degrees Forward	Tilt Degrees Back
Standard	78.3" (1990mm)	118" (3.0m)	6" (150mm)	6	10
Standard	84.3" (2140mm)	130" (3.3m)	6" (150mm)	6	10
Standard	100" (2540mm)	157" (4.0m)	6" (150mm)	6	10
Dual	84.3" (2140mm)	130" (3.3m)	Full	6	10
Triple	82.3" (2090mm)	177" (4.5m)	Full	6	6
Triple	85" (2180mm)	188" (4.8m)	Full	6	6
Triple	88" (2240mm)	197" (5.0m)	Full	6	6

Call Factory for other mast options, derating of capacity.
 All Specifications are subject to updates and changes without notice.

CUSHION TIRE - WFG40-50C



Standard Specifications

		<i>WORLD-LIFE</i>	<i>WORLD-LIFE</i>
Characteristics	1. Manufacturer	WORLD-LIFE	WORLD-LIFE
	2. Model (C=Cushion Tire)	WFG 40C	WFG 50C
	3. Basic Load Capacity	4,000 lb. (2,000kg)	5,000 lb. (2,500 kg)
	4. Load Center	24" (500mm)	24" (500mm)
	5. Power Type	LPG	LPG
	6. Operator Position	Sit Down, Riding	Sit Down, Riding
	7. Tire Type	Cushion	Cushion
	8. Wheels (x=driven)	2x front / 2 rear	2x front / 2 rear
Dimensions	9. Overhead Guard Height	78.7" (2000mm)	78.7" (2000mm)
	10. Length to Face of Forks	89" (2265mm)	91.3" (2320mm)
	11. Width *	41.7" (1060mm)	41.7" (1060mm)
	12. Carriage Width	36.4" (925mm)	36.4" (925mm)
	13. Fork Size *	42" (1070mm)	42" (1070mm)
	14. Wheel Center to Face of Forks	16.3" (415mm)	16.3" (415mm)
	15. Wheel Base	55.1" (1400mm)	55.1" (1400mm)
	16. Turning Radius	76.5" (1945mm)	78.5" (1995mm)
	17. Intersecting Axle	72.5" (1841mm)	74.5" (1892mm)
Performance	18. Speed - Travel	10 m.p.h.	10 m.p.h.
	19. Speed - Lifting with/without load	106 / 120 f.p.m	106 / 120 f.p.m
	20. Speed - Lowering with/without load	98 / 86.6 f.p.m.	98 / 86.6 f.p.m.
	21. Drawbar Pull with/without load	4410 / 1675	4410 / 1765
	22. Gradeability with/without load	30 / 21	29 / 18
Tires & Brakes	23. Tire Size - Front (Drive)	21 x 7 x 15	21 x 7 x 15
	24. Tire Size - Rear (Steer)	16.25 x 5 x 11.25	16.25 x 5 x 11.25
	25. Ground Clearance - Minimum	3.5" (89mm)	3.5" (89mm)
	26. Brake System (Service)	Hydraulic	Hydraulic
	27. Brake System (Parking)	Mechanical	Mechanical
Engine & Trans.	28. Battery Voltage	12	12
	29. Engine (Standard) / (Optional)	G.M. 3.0	G.M. 3.0
	30. Number of Cylinders	4	4
	31. Rated Horsepower @ R.P.M.	75 @ 3000	75 @ 3000
	32. Displacement (Cid)	181	181
	33. Transmission	Powershift	Powershift
	34. Truck Weight	7440 lb.(3374 kg)	8223 lb.(3730 kg)

* Other Sizes Available

CUSHION TIRE WFG40-50C



Features & Benefits

- GM 3.0L, 4 cycle, 4 cylinders, 75 H.P., 181 cu. in. displacement. Nodular iron crankshaft for increased strength
World-class engine sealing system for superior leak protection. Sintered powdered-metal exhaust valve seats for enhanced durability and noise reduction. Cast Iron: Block, Cylinder head and Intake Manifold.
- Powershift (Automatic) Transmission with separate Inching and Brake Pedals, offers positive operation in tight working areas, especially beneficial working on ramps and inclines.
- High visibility design Mast with Side Thrust Rollers in the carriage for smoother operation and longer life of the mast components.
- Fully Hydrostatic Power Steering for smoother operation and many fewer parts for lower maintenance costs. This utilizes the largest cylinder and thickest steel for protection of any forklift in its class!
- Large Hydraulically actuated Drum & Shoe type Brakes for positive braking performance and ease of maintenance. Mechanical lever type parking brake for reliability.
- Control Handles are mounted on the dash for operator convenience, and also allows operator to enter/exit the operator compartment from either side of the machine comfortably.
- Tilt Steering Wheel
- Adjustable Seat
- Seat Belt
- Dual Head Lights
- Front Turn Signals
- Rear Turn Signals
- Brake Lights
- Back-up Lights
- Back-up Alarm
- Neutral Safety Switch
- All Welded Overhead Guard
- Integral Gas Tank
- Integral hydraulic tank
- High air Intake
- Cyclone air cleaner
- Insulated engine cover
- Compartment entry step cut-out
- Hand hold for entry
- Radiator overflow bottle
- Third valve & lever
- Horn
- Hour meter
- Charge warning light
- Temperature warning light
- Oil pressure gauge
- Key switch
- Safety load back rest
- ITA class II forks & carriage
- Easy access floor boards
- Rubber safety mat
- Meet or exceed all ANSI B56.1 safety standards for powered industrial trucks and Underwriters Laboratories requirements as to fire hazard.
- Professional service support by Worldwide Dealer Network.
- **World-Lift Authorized Dealer:**

United Services Gp. Inc.
National Municipal Sales
46 Sager Drive
Rochester, NY 14607