



State of West Virginia  
 Department of Administration  
 Purchasing Division  
 2019 Washington Street East  
 Post Office Box 50130  
 Charleston, WV 25305-0130

**Request for  
 Quotation**

RFQ NUMBER
859C2010

PAGE
1

ADDRESS CORRESPONDENCE TO ATTENTION OF
MICHAEL AUSTIN 304-558-2402

VENDOR

\*513133118 800-941-4498  
 DISCOUNT INDUSTRIAL SUPPLY COR  
 912 FIFTH STREET WEST  
  
 HUNTINGTON WV 25701

SHIP TO

DIVISION OF HIGHWAYS  
 VARIOUS LOCALES AS INDICATED  
 BY ORDER

DATE PRINTED	TERMS OF SALE	SHIP VIA	F.O.B.	FREIGHT TERMS
08/14/2008	NET 30 DAYS	BEST WAY	DESTINATION	NO FREIGHT CHARGES

BID OPENING DATE: 08/27/2008 BID OPENING TIME 01:30PM

LINE	QUANTITY	UOP	CAT. NO.	ITEM NUMBER	UNIT PRICE	AMOUNT
0001				345-92		59,812.00
<p>FURNISH ADOPT-A-HIGHWAY VESTS</p> <p>OPEN END CONTRACT</p> <p>TO PROVIDE HIGH VISIBILITY SAFETY VESTS TO THE WV DIVISION OF HIGHWAYS PER THE ATTACHED SPECIFICATIONS.</p> <p>EXHIBIT 3</p> <p>LIFE OF CONTRACT: THIS CONTRACT BECOMES EFFECTIVE ON ..... AND EXTENDS FOR A PERIOD OF ONE (1) YEAR OR UNTIL SUCH "REASONABLE TIME" THEREAFTER AS IS NECESSARY TO OBTAIN A NEW CONTRACT OR RENEW THE ORIGINAL CONTRACT. THE "REASONABLE TIME" PERIOD SHALL NOT EXCEED TWELVE (12) MONTHS. DURING THIS "REASONABLE TIME" THE VENDOR MAY TERMINATE THIS CONTRACT FOR ANY REASON UPON GIVING THE DIRECTOR OF PURCHASING 30 DAYS WRITTEN NOTICE.</p> <p>UNLESS SPECIFIC PROVISIONS ARE STIPULATED ELSEWHERE IN THIS CONTRACT DOCUMENT, THE TERMS, CONDITIONS AND PRICING SET HEREIN ARE FIRM FOR THE LIFE OF THE CONTRACT.</p> <p>RENEWAL: THIS CONTRACT MAY BE RENEWED UPON THE MUTUAL WRITTEN CONSENT OF THE SPENDING UNIT AND VENDOR, SUBMITTED TO THE DIRECTOR OF PURCHASING THIRTY (30) DAYS PRIOR TO THE EXPIRATION DATE. SUCH RENEWAL SHALL BE IN ACCORDANCE WITH THE TERMS AND CONDITIONS OF THE ORIGINAL CONTRACT AND SHALL BE LIMITED TO TWO (2) ONE</p>						

RECEIVED  
 08 AUG 27 PM 12:21  
 PURCHASING DIVISION  
 STATE OF WV  
  
 PRICE INCREASES  
 WILL BE PASSED  
 ON AS THEY ARE  
 RECEIVED FROM  
 THE MANUFACTURER.

SEE REVERSE SIDE FOR TERMS AND CONDITIONS			
SIGNATURE	TELEPHONE	DATE	
<i>Thomas L. Mason, Jr.</i>	800-941-4498	8/27/2008	
TITLE	FEIN	ADDRESS CHANGES TO BE NOTED ABOVE	
PRESIDENT	55-0748473		

WHEN RESPONDING TO RFQ, INSERT NAME AND ADDRESS IN SPACE ABOVE LABELED 'VENDOR'

**GENERAL TERMS & CONDITIONS**  
**REQUEST FOR QUOTATION (RFQ) AND REQUEST FOR PROPOSAL (RFP)**

1. Awards will be made in the best interest of the State of West Virginia.
2. The State may accept or reject in part, or in whole, any bid.
3. All quotations are governed by the *West Virginia Code* and the *Legislative Rules* of the Purchasing Division.
4. Prior to any award, the apparent successful vendor must be properly registered with the Purchasing Division and have paid the required \$125 fee.
5. All services performed or goods delivered under State Purchase Order/Contracts are to be continued for the term of the Purchase Order/Contracts, contingent upon funds being appropriated by the Legislature or otherwise being made available. In the event funds are not appropriated or otherwise available for these services or goods, this Purchase Order/Contract becomes void and of no effect after June 30.
6. Payment may only be made after the delivery and acceptance of goods or services.
7. Interest may be paid for late payment in accordance with the *West Virginia Code*.
8. Vendor preference will be granted upon written request in accordance with the *West Virginia Code*.
9. The State of West Virginia is exempt from federal and state taxes and will not pay or reimburse such taxes.
10. The Director of Purchasing may cancel any Purchase Order/Contract upon 30 days written notice to the seller.
11. The laws of the State of West Virginia and the *Legislative Rules* of the Purchasing Division shall govern all rights and duties under the Contract, including without limitation the validity of this Purchase Order/Contract.
12. Any reference to automatic renewal is hereby deleted. The Contract may be renewed only upon mutual written agreement of the parties.
13. **BANKRUPTCY:** In the event the vendor/contractor files for bankruptcy protection, this Contract may be deemed null and void, and terminated without further order.
14. **HIPAA BUSINESS ASSOCIATE ADDENDUM:** The West Virginia State Government HIPAA Business Associate Addendum (BAA), approved by the Attorney General, and available online at the Purchasing Division's web site (<http://www.state.wv.us/admin/purchase/vrc/hipaa.htm>) is hereby made part of the agreement. Provided that, the Agency meets the definition of a Cover Entity (45 CFR §160.103) and will be disclosing Protected Health Information (45 CFR §160.103) to the vendor.
15. **WEST VIRGINIA ALCOHOL & DRUG-FREE WORKPLACE ACT:** If this Contract constitutes a public improvement construction contract as set forth in Article 1D, Chapter 21 of the West Virginia Code ("The West Virginia Alcohol and Drug-Free Workplace Act"), then the following language shall hereby become part of this Contract: "The contractor and its subcontractors shall implement and maintain a written drug-free workplace policy in compliance with the West Virginia Alcohol and Drug-Free Workplace Act, as set forth in Article 1D, Chapter 21 of the West Virginia Code. The contractor and its subcontractors shall provide a sworn statement in writing, under the penalties of perjury, that they maintain a valid drug-free work place policy in compliance with the West Virginia and Drug-Free Workplace Act. It is understood and agreed that this Contract shall be cancelled by the awarding authority if the Contractor: 1) Fails to implement its drug-free workplace policy; 2) Fails to provide information regarding implementation of the contractor's drug-free workplace policy at the request of the public authority; or 3) Provides to the public authority false information regarding the contractor's drug-free workplace policy."

---

**INSTRUCTIONS TO BIDDERS**

1. Use the quotation forms provided by the Purchasing Division.
2. **SPECIFICATIONS:** Items offered must be in compliance with the specifications. Any deviation from the specifications must be clearly indicated by the bidder. Alternates offered by the bidder as **EQUAL** to the specifications must be clearly defined. A bidder offering an alternate should attach complete specifications and literature to the bid. The Purchasing Division may waive minor deviations to specifications.
3. Complete all sections of the quotation form.
4. Unit prices shall prevail in case of discrepancy.
5. All quotations are considered F.O.B. destination unless alternate shipping terms are clearly identified in the quotation.
6. **BID SUBMISSION:** All quotations must be delivered by the bidder to the office listed below prior to the date and time of the bid opening. Failure of the bidder to deliver the quotations on time will result in bid disqualifications: Department of Administration, Purchasing Division, 2019 Washington Street East, P.O. Box 50130, Charleston, WV 25305-0130.



State of West Virginia  
 Department of Administration  
 Purchasing Division  
 2019 Washington Street East  
 Post Office Box 50130  
 Charleston, WV 25305-0130

# Request for Quotation

RFO NUMBER  
**859C2010**

PAGE  
**2**

ADDRESS CORRESPONDENCE TO ATTENTION OF:  
**MICHAEL AUSTIN**  
**304-558-2402**

\*513133118 800-941-4498  
**DISCOUNT INDUSTRIAL SUPPLY COR**  
**912 FIFTH STREET WEST**  
  
**HUNTINGTON WV 25701**

**DIVISION OF HIGHWAYS**  
**VARIOUS LOCALES AS INDICATED**  
**BY ORDER**

VENDOR

SHIP TO

DATE PRINTED	TERMS OF SALE	SHIP VIA	F.O.B.	FREIGHT TERMS
08/14/2008				

BID OPENING DATE: **08/27/2008** BID OPENING TIME **01:30PM**

LINE	QUANTITY	UOP	CAT. NO.	ITEM NUMBER	UNIT PRICE	AMOUNT
<p><b>(1) YEAR PERIODS.</b></p> <p><b>CANCELLATION: THE DIRECTOR OF PURCHASING RESERVES THE RIGHT TO CANCEL THIS CONTRACT IMMEDIATELY UPON WRITTEN NOTICE TO THE VENDOR IF THE COMMODITIES AND/OR SERVICES SUPPLIED ARE OF AN INFERIOR QUALITY OR DO NOT CONFORM TO THE SPECIFICATIONS OF THE BID AND CONTRACT HEREIN.</b></p> <p><b>OPEN MARKET CLAUSE: THE DIRECTOR OF PURCHASING MAY AUTHORIZE A SPENDING UNIT TO PURCHASE ON THE OPEN MARKET, WITHOUT THE FILING OF A REQUISITION OR COST ESTIMATE, ITEMS SPECIFIED ON THIS CONTRACT FOR IMMEDIATE DELIVERY IN EMERGENCIES DUE TO UNFORESEEN CAUSES (INCLUDING BUT NOT LIMITED TO DELAYS IN TRANSPORTATION OR AN UNANTICIPATED INCREASE IN THE VOLUME OF WORK.)</b></p> <p><b>QUANTITIES: QUANTITIES LISTED IN THE REQUISITION ARE APPROXIMATIONS ONLY, BASED ON ESTIMATES SUPPLIED BY THE STATE SPENDING UNIT. IT IS UNDERSTOOD AND AGREED THAT THE CONTRACT SHALL COVER THE QUANTITIES ACTUALLY ORDERED FOR DELIVERY DURING THE TERM OF THE CONTRACT, WHETHER MORE OR LESS THAN THE QUANTITIES SHOWN.</b></p> <p><b>ORDERING PROCEDURE: SPENDING UNIT(S) SHALL ISSUE A WRITTEN STATE CONTRACT ORDER (FORM NUMBER WV-39) TO THE VENDOR FOR COMMODITIES COVERED BY THIS CONTRACT. THE ORIGINAL COPY OF THE WV-39 SHALL BE MAILED TO THE VENDOR AS AUTHORIZATION FOR SHIPMENT, A SECOND COPY MAILED TO THE PURCHASING DIVISION, AND A THIRD COPY RETAINED BY THE SPENDING UNIT.</b></p> <p><b>BANKRUPTCY: IN THE EVENT THE VENDOR/CONTRACTOR FILES FOR BANKRUPTCY PROTECTION, THIS CONTRACT IS AUTOMATICALLY NULL AND VOID, AND IS TERMINATED WITHOUT FURTHER ORDER.</b></p>						

SEE REVERSE SIDE FOR TERMS AND CONDITIONS

SIGNATURE	TELEPHONE	DATE
TITLE	FEIN	ADDRESS CHANGES TO BE NOTED ABOVE

WHEN RESPONDING TO RFQ, INSERT NAME AND ADDRESS IN SPACE ABOVE LABELED 'VENDOR'



State of West Virginia  
 Department of Administration  
 Purchasing Division  
 2019 Washington Street East  
 Post Office Box 50130  
 Charleston, WV 25305-0130

# Request for Quotation

RFQ NUMBER
859C2010

PAGE
3

ADDRESS CORRESPONDENCE TO ATTENTION OF:
MICHAEL AUSTIN 304-558-2402

VENDOR

\*513133118      800-941-4498  
 DISCOUNT INDUSTRIAL SUPPLY COR  
 912 FIFTH STREET WEST  
  
 HUNTINGTON WV 25701

SHIP TO

DIVISION OF HIGHWAYS  
 VARIOUS LOCALES AS INDICATED  
 BY ORDER

DATE PRINTED	TERMS OF SALE	SHIP VIA	F.O.B.	FREIGHT TERMS
08/14/2008				

BID OPENING DATE: **08/27/2008**      BID OPENING TIME **01:30PM**

LINE	QUANTITY	UOP	CAT. NO.	ITEM NUMBER	UNIT PRICE	AMOUNT
<p>THE TERMS AND CONDITIONS CONTAINED IN THIS CONTRACT SHALL SUPERSEDE ANY AND ALL SUBSEQUENT TERMS AND CONDITIONS WHICH MAY APPEAR ON ANY ATTACHED PRINTED DOCUMENTS SUCH AS PRICE LISTS, ORDER FORMS, SALES AGREEMENTS OR MAINTENANCE AGREEMENTS, INCLUDING ANY ELECTRONIC MEDIUM SUCH AS CD-ROM.</p> <p>REV. 04/11/2001</p> <p>PURCHASING CARD ACCEPTANCE: THE STATE OF WEST VIRGINIA CURRENTLY UTILIZES A VISA PURCHASING CARD PROGRAM WHICH IS ISSUED THROUGH A BANK. THE SUCCESSFUL VENDOR MUST ACCEPT THE STATE OF WEST VIRGINIA VISA PURCHASING CARD FOR PAYMENT OF ALL ORDERS PLACED BY ANY STATE AGENCY AS A CONDITION OF AWARD.</p> <p>EXHIBIT 10</p> <p>REQUISITION NO.: .....</p> <p>ADDENDUM ACKNOWLEDGEMENT</p> <p>I HEREBY ACKNOWLEDGE RECEIPT OF THE FOLLOWING CHECKED ADDENDUM(S) AND HAVE MADE THE NECESSARY REVISIONS TO MY PROPOSAL, PLANS AND/OR SPECIFICATION, ETC.</p> <p>ADDENDUM NO.'S:</p> <p>NO. 1 <i>[Signature]</i></p> <p>NO. 2 <i>[Signature]</i></p>						

SEE REVERSE SIDE FOR TERMS AND CONDITIONS			
SIGNATURE	TELEPHONE	DATE	
TITLE	FEIN	ADDRESS CHANGES TO BE NOTED ABOVE	

WHEN RESPONDING TO RFQ, INSERT NAME AND ADDRESS IN SPACE ABOVE LABELED 'VENDOR'



State of West Virginia  
 Department of Administration  
 Purchasing Division  
 2019 Washington Street East  
 Post Office Box 50130  
 Charleston, WV 25305-0130

**Request for  
 Quotation**

RFQ NUMBER  
**859C2010**

PAGE  
**4**

ADDRESS CORRESPONDENCE TO ATTENTION OF  
**MICHAEL AUSTIN  
 304-558-2402**

BIDDING

\*513133118 800-941-4498  
 DISCOUNT INDUSTRIAL SUPPLY COR  
 912 FIFTH STREET WEST  
  
 HUNTINGTON WV 25701

SHIP TO

DIVISION OF HIGHWAYS  
 VARIOUS LOCALES AS INDICATED  
 BY ORDER

DATE PRINTED <b>08/14/2008</b>	TERMS OF SALE	SHIP VIA	F.O.B.	FREIGHT TERMS
-----------------------------------	---------------	----------	--------	---------------

BID OPENING DATE: **08/27/2008** BID OPENING TIME **01:30PM**

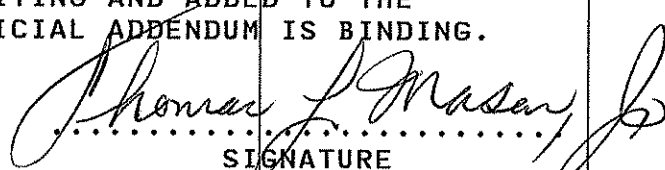
LINE	QUANTITY	UOP	CAT NO.	ITEM NUMBER	UNIT PRICE	AMOUNT
NO. 3						
NO. 4						
NO. 5						
<p>I UNDERSTAND THAT FAILURE TO CONFIRM THE RECEIPT OF THE ADDENDUM(S) MAY BE CAUSE FOR REJECTION OF BIDS.</p> <p>VENDOR MUST CLEARLY UNDERSTAND THAT ANY VERBAL REPRESENTATION MADE OR ASSUMED TO BE MADE DURING ANY ORAL DISCUSSION HELD BETWEEN VENDOR'S REPRESENTATIVES AND ANY STATE PERSONNEL IS NOT BINDING. ONLY THE INFORMATION ISSUED IN WRITING AND ADDED TO THE SPECIFICATIONS BY AN OFFICIAL ADDENDUM IS BINDING.</p> <p style="text-align: center;">             .....            SIGNATURE            DISCOUNT INDUSTRIAL SUPPLY CORP.            COMPANY            8/27/2008            .....            DATE         </p> <p>REV. 11/96</p> <p style="text-align: center;">VENDOR PREFERENCE CERTIFICATE</p> <p>CERTIFICATION AND APPLICATION* IS HEREBY MADE FOR PREFERENCE IN ACCORDANCE WITH WEST VIRGINIA CODE, 5A-3-37 (DOES NOT APPLY TO CONSTRUCTION CONTRACTS).</p>						

SEE REVERSE SIDE FOR TERMS AND CONDITIONS

SIGNATURE	TELEPHONE	DATE
TITLE	FEIN	ADDRESS CHANGES TO BE NOTED ABOVE

WHEN RESPONDING TO RFQ, INSERT NAME AND ADDRESS IN SPACE ABOVE LABELED 'VENDOR'



State of West Virginia  
 Department of Administration  
 Purchasing Division  
 2019 Washington Street East  
 Post Office Box 50130  
 Charleston, WV 25305-0130

# Request for Quotation

RFQ NUMBER:  
**859C2010**

PAGE:  
**5**

ADDRESS CORRESPONDENCE TO ATTENTION OF:  
**MICHAEL AUSTIN  
 304-558-2402**

VENDOR

\*513133118      800-941-4498  
 DISCOUNT INDUSTRIAL SUPPLY COR  
 912 FIFTH STREET WEST  
  
 HUNTINGTON WV 25701

SHIP TO

DIVISION OF HIGHWAYS  
 VARIOUS LOCALES AS INDICATED  
 BY ORDER

DATE PRINTED	TERMS OF SALE	SHIP VIA	F.O.B.	FREIGHT TERMS
08/14/2008				

BID OPENING DATE: **08/27/2008**      BID OPENING TIME **01:30PM**

LINE	QUANTITY	UOP	CAT NO	ITEM NUMBER	UNIT PRICE	AMOUNT
<p>A. APPLICATION IS MADE FOR 2.5% PREFERENCE FOR THE REASON CHECKED:</p> <p>( ) BIDDER IS AN INDIVIDUAL RESIDENT VENDOR AND HAS RESIDED CONTINUOUSLY IN WEST VIRGINIA FOR FOUR (4) YEARS IMMEDIATELY PRECEDING THE DATE OF THIS CERTIFICATION; OR</p> <p><input checked="" type="checkbox"/> BIDDER IS A PARTNERSHIP, ASSOCIATION OR CORPORATION RESIDENT VENDOR AND HAS MAINTAINED ITS HEAD-QUARTERS OR PRINCIPAL PLACE OF BUSINESS CONTINUOUSLY IN WEST VIRGINIA FOR FOUR (4) YEARS IMMEDIATELY PRECEDING THE DATE OF THIS CERTIFICATION; OR 80% OF THE OWNERSHIP INTEREST OF BIDDER IS HELD BY ANOTHER INDIVIDUAL, PARTNERSHIP, ASSOCIATION OR CORPORATION RESIDENT VENDOR WHO HAS MAINTAINED ITS HEADQUARTERS OR PRINCIPAL PLACE OF BUSINESS CONTINUOUSLY IN WEST VIRGINIA FOR FOUR (4) YEARS IMMEDIATELY PRECEDING THE DATE OF THIS CERTIFICATION; OR</p> <p>( ) BIDDER IS A CORPORATION NONRESIDENT VENDOR WHICH HAS AN AFFILIATE OR SUBSIDIARY WHICH EMPLOYS A MINIMUM OF ONE HUNDRED STATE RESIDENTS AND WHICH HAS MAINTAINED ITS HEADQUARTERS OR PRINCIPAL PLACE OF BUSINESS WITHIN WEST VIRGINIA CONTINUOUSLY FOR THE FOUR (4) YEARS IMMEDIATELY PRECEDING THE DATE OF THIS CERTIFICATION.</p> <p>B. APPLICATION IS MADE FOR 2.5% PREFERENCE FOR THE REASON CHECKED:</p> <p><input checked="" type="checkbox"/> BIDDER IS A RESIDENT VENDOR WHO CERTIFIES THAT, DURING THE LIFE OF THE CONTRACT, ON AVERAGE AT LEAST 75% OF THE EMPLOYEES WORKING ON THE PROJECT BEING BID ARE RESIDENTS OF WEST VIRGINIA WHO HAVE RESIDED IN THE STATE CONTINUOUSLY FOR THE TWO YEARS IMMEDIATELY</p>						

SEE REVERSE SIDE FOR TERMS AND CONDITIONS

SIGNATURE	TELEPHONE	DATE
TITLE	FEIN	ADDRESS CHANGES TO BE NOTED ABOVE

WHEN RESPONDING TO RFQ, INSERT NAME AND ADDRESS IN SPACE ABOVE LABELED 'VENDOR'



State of West Virginia  
 Department of Administration  
 Purchasing Division  
 2019 Washington Street East  
 Post Office Box 50130  
 Charleston, WV 25305-0130

# Request for Quotation

RFQ NUMBER  
**859C2010**

PAGE  
**6**

ADDRESS CORRESPONDENCE TO ATTENTION OF  
**MICHAEL AUSTIN  
 304-558-2402**

VENDOR

\*513133118      800-941-4498  
 DISCOUNT INDUSTRIAL SUPPLY COR  
 912 FIFTH STREET WEST  
  
 HUNTINGTON WV 25701

SHIP TO

DIVISION OF HIGHWAYS  
 VARIOUS LOCALES AS INDICATED  
 BY ORDER

DATE PRINTED	TERMS OF SALE	SHIP VIA	F.O.B.	FREIGHT TERMS
08/14/2008				

BID OPENING DATE: **08/27/2008**      BID OPENING TIME **01:30PM**

LINE	QUANTITY	UOP	CAT. NO.	ITEM NUMBER	UNIT PRICE	AMOUNT
<p>PRECEDING SUBMISSION OF THIS BID;            OR            ( ) BIDDER IS A NONRESIDENT VENDOR EMPLOYING A MINIMUM OF ONE HUNDRED STATE RESIDENTS OR IS A NONRESIDENT VENDOR WITH AN AFFILIATE OR SUBSIDIARY WHICH MAINTAINS ITS HEADQUARTERS OR PRINCIPAL PLACE OF BUSINESS WITHIN WEST VIRGINIA EMPLOYING A MINIMUM OF ONE HUNDRED STATE RESIDENTS WHO CERTIFIES THAT, DURING THE LIFE OF THE CONTRACT, ON AVERAGE AT LEAST 75% OF THE EMPLOYEES OR BIDDERS' AFFILIATE'S OR SUBSIDIARY'S EMPLOYEES ARE RESIDENTS OF WEST VIRGINIA WHO HAVE RESIDED IN THE STATE CONTINUOUSLY FOR THE TWO YEARS IMMEDIATELY PRECEDING SUBMISSION OF THIS BID.</p> <p>BIDDER UNDERSTANDS IF THE SECRETARY OF TAX &amp; REVENUE DETERMINES THAT A BIDDER RECEIVING PREFERENCE HAS FAILED TO CONTINUE TO MEET THE REQUIREMENTS FOR SUCH PREFERENCE, THE SECRETARY MAY ORDER THE DIRECTOR OF PURCHASING TO: (A) RESCIND THE CONTRACT OR PURCHASE ORDER ISSUED; OR (B) ASSESS A PENALTY AGAINST SUCH BIDDER IN AN AMOUNT NOT TO EXCEED 5% OF THE BID AMOUNT AND THAT SUCH PENALTY WILL BE PAID TO THE CONTRACTING AGENCY OR DEDUCTED FROM ANY UNPAID BALANCE ON THE CONTRACT OR PURCHASE ORDER.</p> <p>BY SUBMISSION OF THIS CERTIFICATE, BIDDER AGREES TO DISCLOSE ANY REASONABLY REQUESTED INFORMATION TO THE PURCHASING DIVISION AND AUTHORIZES THE DEPARTMENT OF TAX AND REVENUE TO DISCLOSE TO THE DIRECTOR OF PURCHASING APPROPRIATE INFORMATION VERIFYING THAT BIDDER HAS PAID THE REQUIRED BUSINESS TAXES, PROVIDED THAT SUCH INFORMATION DOES NOT CONTAIN THE AMOUNTS OF TAXES PAID NOR ANY OTHER INFORMATION DEEMED BY THE TAX COMMISSIONER TO BE CONFIDENTIAL.</p> <p>UNDER PENALTY OF LAW FOR FALSE SWEARING (WEST VIRGINIA</p>						

SEE REVERSE SIDE FOR TERMS AND CONDITIONS

SIGNATURE	TELEPHONE	DATE
TITLE	FEIN	ADDRESS CHANGES TO BE NOTED ABOVE

WHEN RESPONDING TO RFQ, INSERT NAME AND ADDRESS IN SPACE ABOVE LABELED 'VENDOR'



State of West Virginia  
 Department of Administration  
 Purchasing Division  
 2019 Washington Street East  
 Post Office Box 50130  
 Charleston, WV 25305-0130

# Request for Quotation

RFQ NUMBER  
**859C2010**

PAGE  
**7**

ADDRESS CORRESPONDENCE TO ATTENTION OF  
**MICHAEL AUSTIN  
 304-558-2402**

VENDOR

**\*513133118 800-941-4498**  
**DISCOUNT INDUSTRIAL SUPPLY COR**  
**912 FIFTH STREET WEST**  
  
**HUNTINGTON WV 25701**

SHIP TO

**DIVISION OF HIGHWAYS**  
**VARIOUS LOCALES AS INDICATED**  
**BY ORDER**

DATE PRINTED	TERMS OF SALE	SHIP VIA	F.O.B.	FREIGHT TERMS
08/14/2008				

BID OPENING DATE: **08/27/2008** BID OPENING TIME **01:30PM**

LINE	QUANTITY	UOP	CAT. NO.	ITEM NUMBER	UNIT PRICE	AMOUNT
------	----------	-----	----------	-------------	------------	--------

CODE 61-5-3), BIDDER HEREBY CERTIFIES THAT THIS CERTIFICATE IS TRUE AND ACCURATE IN ALL RESPECTS; AND THAT IF A CONTRACT IS ISSUED TO BIDDER AND IF ANYTHING CONTAINED WITHIN THIS CERTIFICATE CHANGES DURING THE TERM OF THE CONTRACT, BIDDER WILL NOTIFY THE PURCHASING DIVISION IN WRITING IMMEDIATELY.

BIDDER: DISCOUNT INDUSTRIAL SUPPLY CORP.

DATE: 8/27/2008

SIGNED: *Thomas J. Mason, Jr.*

TITLE: PRESIDENT

\* CHECK ANY COMBINATION OF PREFERENCE CONSIDERATION(S) IN EITHER "A" OR "B", OR BOTH "A" AND "B" WHICH YOU ARE ENTITLED TO RECEIVE. YOU MAY REQUEST UP TO THE MAXIMUM 5% PREFERENCE FOR BOTH "A" AND "B". (REV. 12/00)

**NOTICE**

**A SIGNED BID MUST BE SUBMITTED TO:**

DEPARTMENT OF ADMINISTRATION  
 PURCHASING DIVISION  
 BUILDING 15  
 2019 WASHINGTON STREET, EAST  
 CHARLESTON, WV 25305-0130

THE BID SHOULD CONTAIN THIS INFORMATION ON THE FACE OF

SEE REVERSE SIDE FOR TERMS AND CONDITIONS

SIGNATURE	TELEPHONE	DATE
-----------	-----------	------

TITLE	FEIN	ADDRESS CHANGES TO BE NOTED ABOVE
-------	------	-----------------------------------

WHEN RESPONDING TO RFQ, INSERT NAME AND ADDRESS IN SPACE ABOVE LABELED 'VENDOR'





**WVDOH-Traffic Engineering Division  
Specifications for Fluorescent Red-orange ANSI/ISEA 107-2004 Class 2  
Low Cost "Adopt-A-Highway" Vests**

**DESCRIPTION:**

This specification is for finished ANSI/ISEA 107-2004 Class 2 low cost "Adopt-A-Highway" vests. The garments must be manufactured using ANSI/ISEA 107-2004 certified background and reflective component materials and meet all ANSI/ISEA 107-2004 design requirements. Component materials utilized to manufacture garments for this Contract shall be separately certified to ANSI/ISEA 107-2004 by a competent and qualified independent laboratory

**ITEMS:**

Items included on this Contract are as follows:

- Item 1 shall be for a fluorescent-orange colored low cost safety vest with silver reflective striping. This vest shall include a silk screened logo reading "ADOPT-A-HWY" unless otherwise specified. This vest shall be adjustable from size M to 2X.
- Item 2 shall be for a fluorescent-orange colored low cost safety vest with silver reflective striping. This vest shall include a silk screened logo reading "ADOPT-A-HWY" unless otherwise specified. This vest shall be adjustable from size 3X to 4X.
- Item 3 shall be for a fluorescent-orange colored low cost safety vest with silver reflective striping, adjustable from size M to 2X. No logo required.
- Item 4 shall be for a fluorescent-orange colored low cost safety vest with silver reflective striping, adjustable from size 3X to 4X. No logo required.

**MATERIALS:**

**NOTE:** All references in this specification to the "ANSI-107" standard shall be interpreted as referencing the ANSI/ISEA (American National Standards Institute / International Safety Equipment Association) 107-2004 American National Standard for High-Visibility Safety Apparel and Headwear.

**Background Material:**

1. The background material used to manufacture all vests supplied as part of this Contract shall be of the manufacturer's choosing. However, the material utilized shall meet the requirements under Item 2 below, shall be a solid (non-mesh) material, and shall have a maximum weight of 3.7 oz per sq yd.
2. The background material used to manufacture all vests supplied as part of this Contract shall meet the chromaticity, luminance factor, applicable colorfastness, dimensional change, bursting strength, and tear resistance requirements, as applicable, of the ANSI-107 standard and shall have third-party certificates of compliance to be made available upon request by the WVDOH.
3. Background materials used on all vests shall be flame retardant.

**Reflective Material:**

1. The reflective striping for all Items shall be ANSI-107 Level 2 reflective material and shall be 2 inches wide.
2. The reflective striping shall meet care label recommendations per ANSI-107 and shall have independent third-party certificates of compliance to be made available upon request by the WVDOH.
3. The retroreflective striping used to manufacture all vests supplied as part of this Contract shall meet the initial retroreflective performance and "retroreflective performance after test exposure" requirements of the ANSI-107 specification for Performance Class 2. The retroreflective material shall be exposed to the Abrasion, Flexing, Folding at Cold Temperature, Exposure to Temperature Variation, and After Washing According to Care Label exposures as described in the ANSI-107 specification. Independent third-party certificates of compliance to be made available upon request by the WVDOH.

**Garment Designs:**

1. The vests supplied shall meet the Performance Class 2, photometric performance Level 2 requirements, as defined by the ANSI-107 standard.
2. The striping pattern utilized shall be as shown below. One horizontal, 360 degree stripe shall encircle the torso. One band shall join the torso band from the front to the back over each shoulder. The min clear distance on the back of the vests between the two vertical bands shall be ten-inches (10").
3. These vests shall be manufactured to cover a range of sizes by utilizing side adjustments as shown below. The method of side adjustment shall be hook and loop type, shall utilize two continuous horizontal one-inch min. strips on each side, and shall be designed to provide the ability to adjust continuously, not incrementally, over the range of sizes provided below. Sizing shall be either M-2XL or 3XL-4XL. Fabrication shall be based on the following size chart:

Size	Chest Measurement
M-2XL	42" - 56"
3XL-4XL	58" - 64"

4. The front closure provided for these vests shall be vertical hook and loop as shown below.

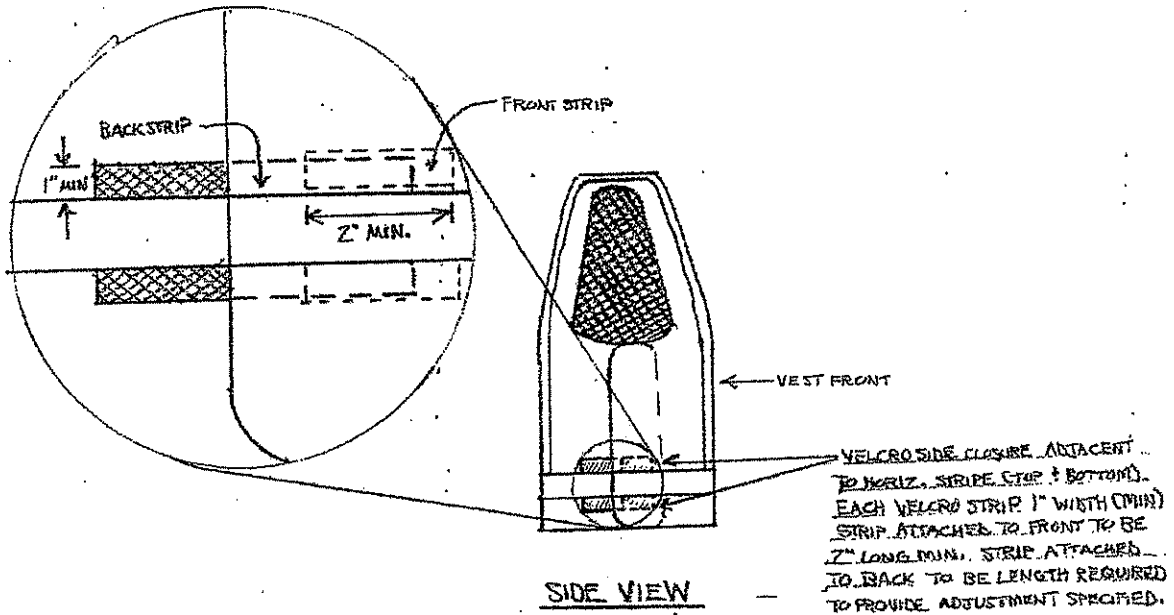
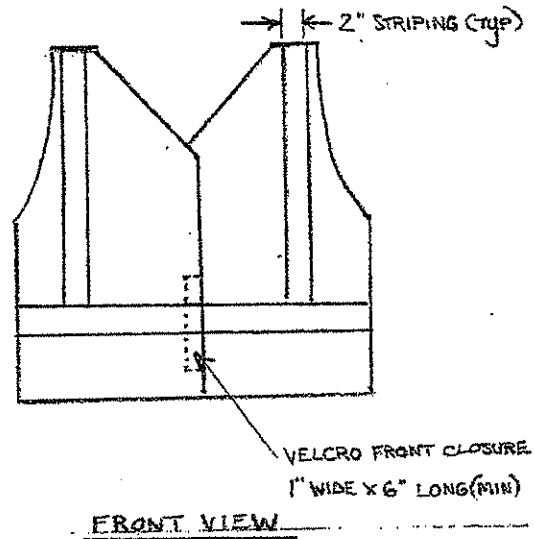

5. These vests shall measure a minimum of 16 inches at the shoulder and shall be a minimum of 24 inches in length.
6. These vests shall meet any other applicable design requirements of the ANSI-107 standard otherwise not covered by this specification.

### General Requirements:

1. All exposed vest edges shall be bound with grey or orange nylon tricot. Edges may also be bound using fluorescent red-orange material identical to the background material of the vest. Exposed edges of "non-woven polyester" vests shall not be required to be bound.
2. Plastic type bindings or borders are not acceptable.

### Logo:

Black silk screened lettering shall be incorporated into the vests supplied under Items 1 and 2, and shall be sized, spaced, and placed as described below:

1. Lettering shall be made up of 1.5 inch tall letters.
2. The font style used shall be Series B Highway Font.
3. Unless otherwise specified on the Purchase Order Release (order), the text on these vests shall read "ADOPT-A-HWY". This text shall be identical in size, shape, and appearance to the drawing included as part of this Contract. This drawing will be made available electronically in pdf and/or vectorized format upon request by contacting Ted Whitmore of the WVDOH Traffic Engineering Division at 304-558-9468 or [ted.j.whitmore@wv.gov](mailto:ted.j.whitmore@wv.gov)
4. All silk screened text provided on vests supplied as part of this Contract shall be free of rough edges, smearing, running, splotches, or other visual defects.
5. If an alternative text is requested on these vests on a particular Purchase Order Release (order), the vendor shall notify either Ted Whitmore or Delano Burford of the WVDOH Traffic Engineering Division at 304-558-3063. After review and approval, the vendor will be provided the requested text in the font size and style described in the formats described above. The text provided shall be no more than one line in length, and no more than 9-3/4 inches long.
6. Lettering shall be screened on the back of the vests, such that the lettering is centered horizontally between the two shoulder bands. Vertically, the lettering shall be placed with the bottom of the letters one-inch (1") above the horizontal reflective stripe.
7. The manufacturer shall be responsible for insuring that the vests supplied under Items 1 and 2 are in full compliance with the ANSI-107 requirements after the above specified lettering is applied.

**Garment Labels:**

Per ANSI-107, the garment labels must include the following information:

- a. Manufacturer
- b. ANSI/ISEA 107-2004
- c. Fabric type
- d. Model #
- e. Size
- f. Pictogram showing garment class and retroreflectivity level
- g. Care guide and maximum number of cycles

Label example:

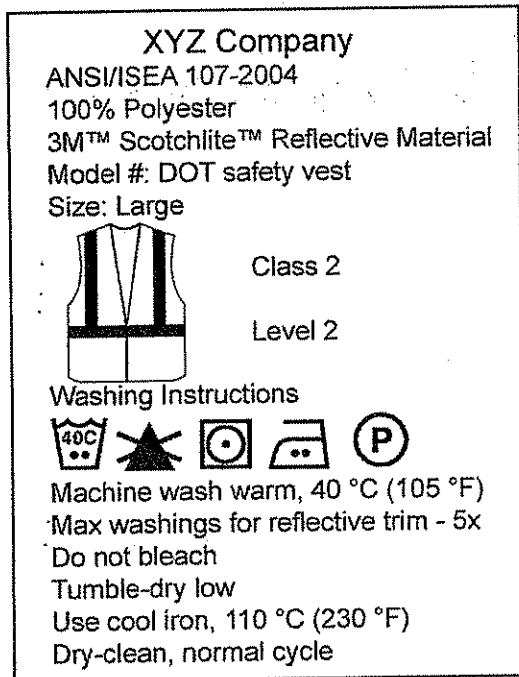
**Certificates:**

ANSI/ISEA 107-2004 certificates for all component materials and the finished garments shall be kept on file by the winner of the bid. Requested copies shall be sent to:

**WVDOH-Traffic Engineering Division  
Bldg 5, Room A550  
1900 Kanawha Blvd. East  
Charleston, WV 25305  
ATTN: Ted Whitmore**

**Packaging:**

Garments shall be packaged in plastic bags with one garment size per bag and one size per shipping carton.

**Workmanship:**

The garments shall be of quality workmanship, comfortable to wear and shall be free of ragged edges, surface blemishes, loose stitches, uneven seams or any defect which would make the vest unsuitable for their intended use.

**SIMILARITY OF ITEMS, AWARD GUIDELINES, AND LOW BIDDER SAMPLE PRODUCTS**

The vests supplied under this Contract shall vary only in size and presence of the specified lettering. All other parameters, such as background material and reflective striping, shall be the same for all vests.

This Contract shall not be considered for award to multiple vendors. Vendors not providing a quote for all items on the Contract will have their bid disqualified.

Subsequent to the opening of bids and the determination of prospective low bidders for this Contract, the DOH will require that a product sample be provided for review and conformance to the Contract specifications. A sample will be required from the vendors submitting the three lowest overall bids. **The sample provided shall be 1 ea. of Item #1. Note, this sample will be requested in order for the vest to be reviewed for compliance to the specifications, and in order to review the quality of the vendor's silk screening. The silk screened text or logo provided on the sample vest will not be required to match the text described above, and may be a message or logo of the vendor's choosing. The vest shall, however, include a sample of the vendor's silk screening in the general area of where the text will typically be applied to the vests supplied as part of this Contract.**

The DOH will notify by fax or email the vendors that are required to submit a sample. **Please note, vendors that are required to submit a sample will be required to have their sample delivered within 7 Calendar Days of notification. Vendors whose sample is not received within 7 Calendar Days will have their bid disqualified.** If necessary, the DOH will contact further low bidders in the event that the bids received from the three lowest bidders can not be accepted due to non-conformance to specifications.



All samples delivered to the DOH are to be sent to the following address:

**WVDOH-Traffic Engineering Division  
Bldg 5, Room A550  
1900 Kanawha Blvd. East  
Charleston, WV 25305  
ATTN: Ted Whitmore**

All samples should be delivered with a label attached with the following information:

- "(Vendor Name)"
- "WVDOH PO Contract Number 859C2010"
- "(Vendor Contact Name)"
- "(Vendor Contact Phone Number)"

### **DELIVERY**

All Release Orders off of this Contract shall be delivered within 30 days A.R.O.

Late delivery charges against the vendor may be assessed at a rate of \$120.00 per Calendar Day exceeding the applicable delivery deadline described above. These charges will be subtracted from the total amount of the Purchase Order Release for which the charges are being assessed. The total amount of the charges shall not exceed the total value of the Purchase Order Release.

All pricing submitted by the vendor shall include shipping costs. Typically, delivery locations will be to, but shall not be limited to, the locations of the ten WVDOH District Headquarters. The cities in which the District Headquarters are located are Charleston, Huntington, Parkersburg, Clarksburg, Burlington, Moundsville, Weston, Elkins, Lewisburg, and Princeton.

The agency or organization issuing orders off of this Contract should include a contact name and phone number on the Release Order for delivery arrangement purposes. If this is done, the vendor, or vendor's shipper, shall notify the contact a minimum of one working day prior to delivery.

### **MINIMUM ORDER SIZE**

There shall be no minimum order size requirement for any Item on this Contract.

**ADOPT - A - HWY**

**BID SCHEDULE**

The following estimated quantities are for bid purposes only. Actual quantities will be determined by the needs of the user agencies and may be increased or decreased.

ITEM	ESTIMATED QUANTITY	DESCRIPTION	UNIT COST	Amount
1	1700	Low Cost "Adopt-A-Highway Vest", Fluorescent-Orange, silk screened "ADOPT-A-HWY" logo (unless otherwise specified), Sizes M through 2XL (adjustable)	14.93	25381.00
2	300	Low Cost "Adopt-A-Highway Vest", Fluorescent-Orange, silk screened "ADOPT-A-HWY" logo (unless otherwise specified), Sizes 3XL through 4XL (adjustable)	17.18	5154.00
3	1700	Low Cost "Adopt-A-Highway Vest", Fluorescent-Orange, Sizes M through 2XL (adjustable). No logo.	14.31	24327.00
4	300	Low Cost "Adopt-A-Highway Vest", Fluorescent-Orange, Sizes 3XL through 4XL (adjustable). No logo.	16.50	4950.00
<b>TOTAL</b>			→	<b>59,812.00</b>

\* PLEASE NOTE THAT ALL VESTS QUOTED ARE US MADE IN NORTH CAROLINA. NO INFERIOR QUALITY IMPORTS WILL BE USED.

STATE OF WEST VIRGINIA  
Purchasing Division

## PURCHASING AFFIDAVIT

### VENDOR OWING A DEBT TO THE STATE:

*West Virginia Code* §5A-3-10a provides that: No contract or renewal of any contract may be awarded by the state or any of its political subdivisions to any vendor or prospective vendor when the vendor or prospective vendor or a related party to the vendor or prospective vendor is a debtor and the debt owed is an amount greater than one thousand dollars in the aggregate.

### PUBLIC IMPROVEMENT CONTRACTS & DRUG-FREE WORKPLACE ACT:

*West Virginia Code* §21-1D-5 provides that: Any solicitation for a public improvement construction contract shall require each vendor that submits a bid for the work to submit at the same time an affidavit that the vendor has a written plan for a drug-free workplace policy in compliance with Article 1D, Chapter 21 of the West Virginia Code. A public improvement construction contract may not be awarded to a vendor who does not have a written plan for a drug-free workplace policy in compliance with Article 1D, Chapter 21 of the West Virginia Code and who has not submitted that plan to the appropriate contracting authority in timely fashion. For a vendor who is a subcontractor, compliance with Section 5, Article 1D, Chapter 21 of the West Virginia Code may take place before their work on the public improvement is begun.

### ANTITRUST:

In submitting a bid to any agency for the state of West Virginia, the bidder offers and agrees that if the bid is accepted the bidder will convey, sell, assign or transfer to the state of West Virginia all rights, title and interest in and to all causes of action it may now or hereafter acquire under the antitrust laws of the United States and the state of West Virginia for price fixing and/or unreasonable restraints of trade relating to the particular commodities or services purchased or acquired by the state of West Virginia. Such assignment shall be made and become effective at the time the purchasing agency tenders the initial payment to the bidder.

I certify that this bid is made without prior understanding, agreement, or connection with any corporation, firm, limited liability company, partnership or person or entity submitting a bid for the same materials, supplies, equipment or services and is in all respects fair and without collusion or fraud. I further certify that I am authorized to sign the certification on behalf of the bidder or this bid.

### LICENSING:

Vendors must be licensed and in good standing in accordance with any and all state and local laws and requirements by any state or local agency of West Virginia, including, but not limited to, the West Virginia Secretary of State's Office, the West Virginia Tax Department, West Virginia Insurance Commission, or any other state agencies or political subdivision. Furthermore, the vendor must provide all necessary releases to obtain information to enable the Director or spending unit to verify that the vendor is licensed and in good standing with the above entities.

### CONFIDENTIALITY:

The vendor agrees that he or she will not disclose to anyone, directly or indirectly, any such personally identifiable information or other confidential information gained from the agency, unless the individual who is the subject of the information consents to the disclosure in writing or the disclosure is made pursuant to the agency's policies, procedures and rules. Vendors should visit [www.state.wv.us/admin/purchase/privacy](http://www.state.wv.us/admin/purchase/privacy) for the Notice of Agency Confidentiality Policies.

Under penalty of law for false swearing (West Virginia Code §61-5-3), it is hereby certified that the vendor acknowledges the information in this said affidavit and is in compliance with the requirements as stated.

Vendor's Name: DISCOUNT INDUSTRIAL SUPPLY CORPORATION

Authorized Signature: Thomas L. Mason Date: 8/26/2008