



State of West Virginia
 Department of Administration
 Purchasing Division
 2019 Washington Street East
 Post Office Box 50130
 Charleston, WV 25305-0130

Request for Quotation

RFQ NUMBER:
709EC009

PAGE
1

ADDRESS CORRESPONDENCE TO ATTENTION OF:
MICHAEL AUSTIN
304-558-2402

VENDOR

*709051756 304-346-5301
 WV TRACTOR COMPANY
 PO BOX 473

 CHARLESTON WV 25322

SHIP TO

DIVISION OF HIGHWAYS
 EQUIPMENT DIVISION
 ROUTE 33
 BRUSHY FORK ROAD
 BUCKHANNON, WV
 26201 304-472-1750

DATE PRINTED	TERMS OF SALE	SHIP VIA	F.O.B.	FREIGHT TERMS
12/02/2008	Net 30 Days	Truck	Buckhannon	Prepaid

BID OPENING DATE: **01/07/2009** BID OPENING TIME **01:30PM**

LINE	QUANTITY	UOP	CAT NO	ITEM NUMBER	UNIT PRICE	AMOUNT
0001	1	EA		765-77 BROCE RCT-350		
<p>SELF PROPELLED POWER BROOM</p> <p>OPEN END CONTRACT</p> <p>TO PROVIDE SELF PROPELLED POWER BROOM FOR THE WEST VIRGINIA DIVISION OF HIGHWAYS PER THE ATTACHED SPECIFICATIONS.</p> <p>A MANDATORY PRE-BID CONFERENCE WILL BE HELD ON 12/15/08 AT 10:00 AM, AT THE EQUIPMENT DIVISION, BUCKHANNON, WEST VIRGINIA. FAILURE TO ATTEND PRE-BID WILL RESULT IN BID DISQUALIFICATION.</p> <p>QUESTION: WRITTEN QUESTIONS WILL BE ACCEPTED THROUGH CLOSE OF BUSINESS (5:00 PM EST.) ON THURSDAY 12/11/08. SEND YOUR QUESTIONS TO: PURCHASING DIVISION ATTENTION MICHAEL AUSTIN 2019 WASHINGTON ST., EAST CHARLESTON, WV 25305</p> <p>QUESTIONS MAY BE SENT VIA FAX, E-MAIL, OR REGULAR MAIL. E-MAIL: MICHAEL.D.AUSTIN@WV.GOV FAX: 304-558-4115</p> <p>IT IS THE VENDORS RESPONSIBILITY TO VERIFY THAT THEIR QUESTIONS HAVE BEEN RECEIVED BY CALLING 304-558-2402.</p> <p>EXHIBIT 2</p> <p>LIFE OF CONTRACT: THIS CONTRACT BECOMES EFFECTIVE ON</p>						

SEE REVERSE SIDE FOR TERMS AND CONDITIONS

SIGNATURE <i>Ray Grady</i>	TELEPHONE 346-5301	DATE 1-5-09
TITLE Pres.	FEIN 550621655	ADDRESS CHANGES TO BE NOTED ABOVE

WHEN RESPONDING TO RFQ, INSERT NAME AND ADDRESS IN SPACE ABOVE LABELED 'VENDOR'

**GENERAL TERMS & CONDITIONS
REQUEST FOR QUOTATION (RFQ) AND REQUEST FOR PROPOSAL (RFP)**

1. Awards will be made in the best interest of the State of West Virginia.
2. The State may accept or reject in part, or in whole, any bid.
3. All quotations are governed by the *West Virginia Code* and the *Legislative Rules* of the Purchasing Division.
4. Prior to any award, the apparent successful vendor must be properly registered with the Purchasing Division and have paid the required \$125 fee.
5. All services performed or goods delivered under State Purchase Order/Contracts are to be continued for the term of the Purchase Order/Contracts, contingent upon funds being appropriated by the Legislature or otherwise being made available. In the event funds are not appropriated or otherwise available for these services or goods, this Purchase Order/Contract becomes void and of no effect after June 30.
6. Payment may only be made after the delivery and acceptance of goods or services.
7. Interest may be paid for late payment in accordance with the *West Virginia Code*.
8. Vendor preference will be granted upon written request in accordance with the *West Virginia Code*.
9. The State of West Virginia is exempt from federal and state taxes and will not pay or reimburse such taxes.
10. The Director of Purchasing may cancel any Purchase Order/Contract upon 30 days written notice to the seller.
11. The laws of the State of West Virginia and the *Legislative Rules* of the Purchasing Division shall govern all rights and duties under the Contract, including without limitation the validity of this Purchase Order/Contract.
12. Any reference to automatic renewal is hereby deleted. The Contract may be renewed only upon mutual written agreement of the parties.
13. **BANKRUPTCY:** In the event the vendor/contractor files for bankruptcy protection, this Contract may be deemed null and void, and terminated without further order.
14. **HIPAA BUSINESS ASSOCIATE ADDENDUM:** The West Virginia State Government HIPAA Business Associate Addendum (BAA), approved by the Attorney General, and available online at the Purchasing Division's web site (<http://www.state.wv.us/admin/purchase/vrc/hipaa.htm>) is hereby made part of the agreement. Provided that, the Agency meets the definition of a Cover Entity (45 CFR §160.103) and will be disclosing Protected Health Information (45 CFR §160.103) to the vendor.
15. **WEST VIRGINIA ALCOHOL & DRUG-FREE WORKPLACE ACT:** If this Contract constitutes a public improvement construction contract as set forth in Article 1D, Chapter 21 of the West Virginia Code ("The West Virginia Alcohol and Drug-Free Workplace Act"), then the following language shall hereby become part of this Contract: "The contractor and its subcontractors shall implement and maintain a written drug-free workplace policy in compliance with the West Virginia Alcohol and Drug-Free Workplace Act, as set forth in Article 1D, Chapter 21 of the West Virginia Code. The contractor and its subcontractors shall provide a sworn statement in writing, under the penalties of perjury, that they maintain a valid drug-free work place policy in compliance with the West Virginia and Drug-Free Workplace Act. It is understood and agreed that this Contract shall be cancelled by the awarding authority if the Contractor: 1) Fails to implement its drug-free workplace policy; 2) Fails to provide information regarding implementation of the contractor's drug-free workplace policy at the request of the public authority; or 3) Provides to the public authority false information regarding the contractor's drug-free workplace policy."

INSTRUCTIONS TO BIDDERS

1. Use the quotation forms provided by the Purchasing Division.
2. **SPECIFICATIONS:** Items offered must be in compliance with the specifications. Any deviation from the specifications must be clearly indicated by the bidder. Alternates offered by the bidder as **EQUAL** to the specifications must be clearly defined. A bidder offering an alternate should attach complete specifications and literature to the bid. The Purchasing Division may waive minor deviations to specifications.
3. Complete all sections of the quotation form.
4. Unit prices shall prevail in case of discrepancy.
5. All quotations are considered F.O.B. destination unless alternate shipping terms are clearly identified in the quotation.
6. **BID SUBMISSION:** All quotations must be delivered by the bidder to the office listed below prior to the date and time of the bid opening. Failure of the bidder to deliver the quotations on time will result in bid disqualifications: Department of Administration, Purchasing Division, 2019 Washington Street East, P.O. Box 50130, Charleston, WV 25305-0130



State of West Virginia
 Department of Administration
 Purchasing Division
 2019 Washington Street East
 Post Office Box 50130
 Charleston, WV 25305-0130

Request for Quotation

RFO NUMBER
709EC009

PAGE
2

ADDRESS CORRESPONDENCE TO ATTENTION OF
**MICHAEL AUSTIN
 304-558-2402**

PROPERTY

*709051756 304-346-5301
**WV TRACTOR COMPANY
 PO BOX 473
 CHARLESTON WV 25322**

SHIP TO

**DIVISION OF HIGHWAYS
 EQUIPMENT DIVISION
 ROUTE 33
 BRUSHY FORK ROAD
 BUCKHANNON, WV
 26201 304-472-1750**

DATE PRINTED	TERMS OF SALE	SHIP VIA	F.O.B.	FREIGHT TERMS
12/02/2008				

BID OPENING DATE: **01/07/2009** BID OPENING TIME **01:30PM**

LINE	QUANTITY	UOP	CAT. NO.	ITEM NUMBER	UNIT PRICE	AMOUNT
<p>..... AND EXTENDS FOR A PERIOD OF ONE (1) YEAR OR UNTIL SUCH "REASONABLE TIME" THEREAFTER AS IS NECESSARY TO OBTAIN A NEW CONTRACT OR RENEW THE ORIGINAL CONTRACT. THE "REASONABLE TIME" PERIOD SHALL NOT EXCEED TWELVE (12) MONTHS. DURING THIS "REASONABLE TIME" THE VENDOR MAY TERMINATE THIS CONTRACT FOR ANY REASON UPON GIVING THE DIRECTOR OF PURCHASING THIRTY (30) DAYS WRITTEN NOTICE.</p> <p>UNLESS SPECIFIC PROVISIONS ARE STIPULATED IN THIS CONTRACT DOCUMENT, THE TERMS, CONDITIONS, AND PRICING SET HEREIN ARE FIRM FOR THE LIFE OF THE CONTRACT.</p> <p>RENEWAL: THIS CONTRACT MAY BE RENEWED UPON THE MUTUAL WRITTEN CONSENT OF THE SPENDING UNIT AND VENDOR, SUBMITTED TO THE DIRECTOR OF PURCHASING THIRTY (30) DAYS PRIOR TO THE EXPIRATION DATE. SUCH RENEWAL SHALL BE IN ACCORDANCE WITH THE TERMS AND CONDITIONS OF THE ORIGINAL CONTRACT AND SHALL BE LIMITED TO TWO (2) ONE (1) YEAR PERIODS.</p> <p>CANCELLATION: THE DIRECTOR OF PURCHASING RESERVES THE RIGHT TO CANCEL THIS CONTRACT IMMEDIATELY UPON WRITTEN NOTICE TO THE VENDOR IF THE COMMODITIES AND/OR SERVICE SUPPLIED ARE OF AN INFERIOR QUALITY OR DO NOT CONFORM WITH THE SPECIFICATIONS OF THE BID AND CONTRACT HEREIN.</p> <p>OPEN MARKET CLAUSE: THE DIRECTOR OF PURCHASING MAY AUTHORIZE A SPENDING UNIT TO PURCHASE ON THE OPEN MARKET, WITHOUT THE FILING OF A REQUISITION OR COST ESTIMATE, ITEMS SPECIFIED ON THIS CONTRACT FOR IMMEDIATE DELIVERY IN EMERGENCIES DUE TO UNFORESEEN CAUSES (INCLUDING BUT NOT LIMITED TO DELAYS IN TRANSPORTATION OR AN UNANTICIPATED INCREASE IN THE VOLUME OF WORK).</p> <p>QUANTITIES: QUANTITIES LISTED IN THE REQUISITION ARE</p>						

SEE REVERSE SIDE FOR TERMS AND CONDITIONS

SIGNATURE	TELEPHONE	DATE
TITLE	FEIN	ADDRESS CHANGES TO BE NOTED ABOVE

WHEN RESPONDING TO RFQ, INSERT NAME AND ADDRESS IN SPACE ABOVE LABELED 'VENDOR'



State of West Virginia
 Department of Administration
 Purchasing Division
 2019 Washington Street East
 Post Office Box 50130
 Charleston, WV 25305-0130

**Request for
 Quotation**

RFO NUMBER
709EC009

PAGE
3

ADDRESS CORRESPONDENCE TO ATTENTION OF
**MICHAEL AUSTIN
 304-558-2402**

VENDOR

*709051756 304-346-5301
 WV TRACTOR COMPANY
 PO BOX 473
 CHARLESTON WV 25322

SHIP TO

DIVISION OF HIGHWAYS
 EQUIPMENT DIVISION
 ROUTE 33
 BRUSHY FORK ROAD
 BUCKHANNON, WV
 26201 304-472-1750

DATE PRINTED 12/02/2008	TERMS OF SALE	SHIP VIA	F.O.B.	FREIGHT TERMS
-----------------------------------	---------------	----------	--------	---------------

BID OPENING DATE: **01/07/2009** BID OPENING TIME **01:30PM**

LINE	QUANTITY	UOP	CAT NO	ITEM NUMBER	UNIT PRICE	AMOUNT
<p>APPROXIMATIONS ONLY, BASED ON ESTIMATES SUPPLIES BY THE STATE SPENDING UNIT. IT IS UNDERSTOOD AND AGREED THAT THE CONTRACT SHALL COVER THE QUANTITIES ACTUALLY ORDERED FOR DELIVERY DURING THE TERM OF CONTRACT, WHETHER MORE OR LESS THAN THE QUANTITIES SHOWN.</p> <p>ORDERING PROCEDURE: SPENDING UNIT(S) SHALL ISSUE A WRITTEN EQUIPMENT CONTRACT ORDER (FORM NUMBER WV-35) FOR COMMODITIES COVERED BY THIS CONTRACT. THE ORIGINAL WV-35 MUST BE SENT TO THE PURCHASING DIVISION OF THE DEPARTMENT OF ADMINISTRATION. AFTER APPROVAL AND ENCUMBRANCE, ONE COPY OF THE PURCHASE ORDER WILL BE RETURNED TO THE SPENDING UNIT AND ONE COPY FORWARDED TO THE VENDOR AS AUTHORIZATION FOR SHIPMENT. NO ORDER IS VALID UNLESS APPROVED AND ENCUMBERED BY THE PURCHASING DIVISION.</p> <p>BANKRUPTCY: IN THE EVENT THE VENDOR/CONTRACTOR FILES FOR BANKRUPTCY PROTECTION, THIS CONTRACT IS AUTOMATICALLY NULL AND VOID, AND IS TERMINATED WITHOUT FURTHER ORDER.</p> <p>EXHIBIT 4</p> <p>LOCAL GOVERNMENT BODIES: UNLESS THE VENDOR INDICATES IN THE BID HIS REFUSAL TO EXTEND THE PRICES, TERMS, AND CONDITIONS OF THE BID TO COUNTY, SCHOOL, MUNICIPAL AND OTHER LOCAL GOVERNMENT BODIES, THE BID SHALL EXTEND TO POLITICAL SUBDIVISIONS OF THE STATE OF WEST VIRGINIA. IF THE VENDOR DOES NOT WISH TO EXTEND THE PRICES, TERMS, AND CONDITIONS OF THE BID TO ALL POLITICAL SUBDIVISIONS OF THE STATE, THE VENDOR MUST CLEARLY INDICATE SUCH REFUSAL IN HIS BID. SUCH REFUSAL SHALL NOT PREJUDICE THE AWARD OF THIS CONTRACT IN ANY MANNER.</p>						

SEE REVERSE SIDE FOR TERMS AND CONDITIONS

SIGNATURE	TELEPHONE	DATE
TITLE	FEIN	ADDRESS CHANGES TO BE NOTED ABOVE

WHEN RESPONDING TO RFQ, INSERT NAME AND ADDRESS IN SPACE ABOVE LABELED 'VENDOR'



State of West Virginia
 Department of Administration
 Purchasing Division
 2019 Washington Street East
 Post Office Box 50130
 Charleston, WV 25305-0130

Request for Quotation

RFQ NUMBER
709EC009

PAGE
4

ADDRESS CORRESPONDENCE TO ATTENTION OF
MICHAEL AUSTIN 304-558-2402

VENDOR

*709051756 304-346-5301
 WV TRACTOR COMPANY
 PO BOX 473
 CHARLESTON WV 25322

SHIP TO

DIVISION OF HIGHWAYS
 EQUIPMENT DIVISION
 ROUTE 33
 BRUSHY FORK ROAD
 BUCKHANNON, WV
 26201 304-472-1750

DATE PRINTED	TERMS OF SALE	SHIP VIA	F.O.B.	FREIGHT TERMS
12/02/2008				

BID OPENING DATE: 01/07/2009 BID OPENING TIME 01:30PM

LINE	QUANTITY	UOP	CAT. NO	ITEM NUMBER	UNIT PRICE	AMOUNT
	REV. 3/88					
	EXHIBIT 6					
	<p>PRICE ADJUSTMENT PROVISION: THE STATE OF WEST VIRGINIA WILL CONSIDER BIDS THAT CONTAIN PROVISIONS FOR PRICE ADJUSTMENTS PRIOR TO THE ORIGINAL EXPIRATION OF THE CONTRACT, PROVIDED THAT SUCH PRICE ADJUSTMENT COVERS BOTH UPWARD AND DOWNWARD MOVEMENT OF THE COMMODITY PRICE, AND THAT ADJUSTMENT IS BASED ON THE "PASS THROUGH" INCREASE OR DECREASE OF RAW MATERIALS AND/OR LABOR, WHICH MAKE UP ALL OR A SUBSTANTIAL PART OF A PRODUCT. ADJUSTMENTS ARE TO BE BASED UPON AN ACTUAL DOLLAR FIGURE, NOT A PERCENTAGE. ALL PRICE ADJUSTMENT REQUESTS MUST BE SUBSTANTIATED IN A MANNER ACCEPTABLE TO THE DIRECTOR PURCHASING, E.G. GOVERNMENTAL BENCH MARKS, GENERAL MARKET INCREASE, PUBLISHED PRICE LISTS. SUCH REQUESTS FOR AND INCREASE SHOULD BE RECEIVED IN WRITING BY THE DIRECTOR OF PURCHASING AT LEAST 30 DAYS IN ADVANCE OF THE EFFECTIVE DATE OF THE INCREASE. ANY TIME THE VENDOR REQUESTS A PRICE ADJUSTMENT, THE PURCHASING DIVISION MAY EITHER ACCEPT THE PRICE ADJUSTMENT AND AMEND THE CONTRACT ACCORDINGLY OR REJECT THE ADJUSTMENT IN ITS ENTIRETY AND CANCEL THE CONTRACT.</p>					
	EXHIBIT 10					
	ADDENDUM ACKNOWLEDGEMENT					
					709EC009	
					REQUISITION NO.:

SEE REVERSE SIDE FOR TERMS AND CONDITIONS

SIGNATURE	TELEPHONE	DATE
TITLE	FEIN	ADDRESS CHANGES TO BE NOTED ABOVE

WHEN RESPONDING TO RFQ, INSERT NAME AND ADDRESS IN SPACE ABOVE LABELED 'VENDOR'



State of West Virginia
 Department of Administration
 Purchasing Division
 2019 Washington Street East
 Post Office Box 50130
 Charleston, WV 25305-0130

Request for Quotation

RFQ NUMBER
709EC009

PAGE
5

ADDRESS CORRESPONDENCE TO ATTENTION OF
MICHAEL AUSTIN 304-558-2402

VENDOR

*709051756 304-346-5301
 WV TRACTOR COMPANY
 PO BOX 473

 CHARLESTON WV 25322

SHIP TO

DIVISION OF HIGHWAYS
 EQUIPMENT DIVISION
 ROUTE 33
 BRUSHY FORK ROAD
 BUCKHANNON, WV
 26201 304-472-1750

DATE PRINTED	TERMS OF SALE	SHIP VIA	F.O.B.	FREIGHT TERMS
12/02/2008				

BID OPENING DATE: **01/07/2009** BID OPENING TIME **01:30PM**

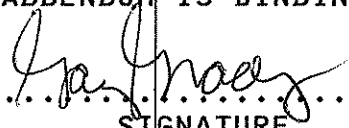
LINE	QUANTITY	UOP	CAT NO	ITEM NUMBER	UNIT PRICE	AMOUNT
<p>I HEREBY ACKNOWLEDGE RECEIPT OF THE FOLLOWING CHECKED ADDENDUM(S) AND HAVE MADE THE NECESSARY REVISIONS TO MY PROPOSAL, PLANS AND/OR SPECIFICATION, ETC.</p> <p>ADDENDUM NO.'S:</p> <p>NO. 1</p> <p>NO. 2</p> <p>NO. 3</p> <p>NO. 4</p> <p>NO. 5</p> <p>I UNDERSTAND THAT FAILURE TO CONFIRM THE RECEIPT OF THE ADDENDUM(S) MAY BE CAUSE FOR REJECTION OF BIDS.</p> <p>VENDOR MUST CLEARLY UNDERSTAND THAT ANY VERBAL REPRESENTATION MADE OR ASSUMED TO BE MADE DURING ANY ORAL DISCUSSION HELD BETWEEN VENDOR'S REPRESENTATIVES AND ANY STATE PERSONNEL IS NOT BINDING. ONLY THE INFORMATION ISSUED IN WRITING AND ADDED TO THE SPECIFICATIONS BY AN OFFICIAL ADDENDUM IS BINDING.</p> <p style="text-align: right;">  SIGNATURE West Virginia Tractor Company COMPANY 1/5/09 DATE </p>						

SEE REVERSE SIDE FOR TERMS AND CONDITIONS

SIGNATURE	TELEPHONE	DATE
TITLE	FEIN	ADDRESS CHANGES TO BE NOTED ABOVE

WHEN RESPONDING TO RFQ, INSERT NAME AND ADDRESS IN SPACE ABOVE LABELED 'VENDOR'



State of West Virginia
 Department of Administration
 Purchasing Division
 2019 Washington Street East
 Post Office Box 50130
 Charleston, WV 25305-0130

Request for Quotation

RFQ NUMBER
709EC009

PAGE
6

ADDRESS CORRESPONDENCE TO ATTENTION OF
MICHAEL AUSTIN 304-558-2402

VENDOR

*709051756 304-346-5301
 WV TRACTOR COMPANY
 PO BOX 473
 CHARLESTON WV 25322

SHIP TO

DIVISION OF HIGHWAYS
 EQUIPMENT DIVISION
 ROUTE 33
 BRUSHY FORK ROAD
 BUCKHANNON, WV
 26201 304-472-1750

DATE PRINTED	TERMS OF SALE	SHIP VIA	F.O.B.	FREIGHT TERMS
12/02/2008				

BID OPENING DATE: 01/07/2009 BID OPENING TIME 01:30PM

LINE	QUANTITY	UQP	CAT. NO.	ITEM NUMBER	UNIT PRICE	AMOUNT
<p>REV. 11/96</p> <p style="text-align: center;">NOTICE</p> <p>A SIGNED BID MUST BE SUBMITTED TO:</p> <p style="text-align: center;">DEPARTMENT OF ADMINISTRATION PURCHASING DIVISION BUILDING 15 2019 WASHINGTON STREET, EAST CHARLESTON, WV 25305-0130</p> <p>THE BID SHOULD CONTAIN THIS INFORMATION ON THE FACE OF THE ENVELOPE OR THE BID MAY NOT BE CONSIDERED:</p> <p>SEALED BID</p> <p>BUYER: 33</p> <p>RFQ. NO.: 709EC009</p> <p>BID OPENING DATE: 1/7/09</p> <p>BID OPENING TIME: 1:30 PM</p> <p>PLEASE PROVIDE A FAX NUMBER IN CASE IT IS NECESSARY TO CONTACT YOU REGARDING YOUR BID: ----- 346-5305</p> <p>CONTACT PERSON (PLEASE PRINT CLEARLY):</p>						

SEE REVERSE SIDE FOR TERMS AND CONDITIONS

SIGNATURE	TELEPHONE	DATE
-----------	-----------	------

TITLE	FEIN	ADDRESS CHANGES TO BE NOTED ABOVE
-------	------	-----------------------------------

WHEN RESPONDING TO RFQ, INSERT NAME AND ADDRESS IN SPACE ABOVE LABELED 'VENDOR'



State of West Virginia
 Department of Administration
 Purchasing Division
 2019 Washington Street East
 Post Office Box 50130
 Charleston, WV 25305-0130

Request for Quotation

RFQ NUMBER
709EC009

PAGE
7

ADDRESS CORRESPONDENCE TO ATTENTION OF:
MICHAEL AUSTIN
304-558-2402

VENDOR

*709051756 304-346-5301
 WV TRACTOR COMPANY
 PO BOX 473

 CHARLESTON WV 25322

SHIP TO

DIVISION OF HIGHWAYS
 EQUIPMENT DIVISION
 ROUTE 33
 BRUSHY FORK ROAD
 BUCKHANNON, WV
 26201 304-472-1750

DATE PRINTED	TERMS OF SALE	SHIP VIA	F.O.B.	FREIGHT TERMS
12/02/2008				

BID OPENING DATE: **01/07/2009** BID OPENING TIME **01:30PM**

LINE	QUANTITY	UOP	CAT NO	ITEM NUMBER	UNIT PRICE	AMOUNT
				Gary Grady		

***** THIS IS THE END OF RFQ 709EC009 ***** TOTAL:						_____

SEE REVERSE SIDE FOR TERMS AND CONDITIONS

SIGNATURE		TELEPHONE		DATE
TITLE	FEIN	ADDRESS CHANGES TO BE NOTED ABOVE		

WHEN RESPONDING TO RFQ, INSERT NAME AND ADDRESS IN SPACE ABOVE LABELED 'VENDOR'

WEST VIRGINIA DEPARTMENT OF TRANSPORTATION
DIVISION OF HIGHWAYS
EQUIPMENT DIVISION

BIDDER'S EVALUATION REPORT

PROCUREMENT SPECIFICATIONS FOR OPEN END CONTRACT
NO. 043-1-D

SELF PROPELLED POWER BROOM

NOTE TO BIDDER: Procurement Specification No. 043-1-D, Paragraph 2.0 recommends the completion and submittal of this Report with your bid. Purpose of this Report is to enable the West Virginia Division of Highways Evaluation Committee to make full and fair evaluation of the bid. Addendums in order, along with a summary of exception as a separate attachment, should be with Bidder's Evaluation Report.
FAILURE TO SUBMIT THIS REPORT, COMPLETE IN ITS ENTIRETY, MAY SUBJECT THE BIDDER TO DISQUALIFICATION.

Reference Requisition No.: 709EC009

Bidder's Name: West Virginia Tractor Company

Address: P.O. Box 473 Charleston, WV 25322

Telephone Number: 346-5301

Years Bidder has been registered to do business with the State of West Virginia: 26 YRS.

Years Company has been an authorized dealer for proposed unit: 5 YRS.

X3.2 Have you complied with all mandatory specifications? YES NO

X4.2 DELIVERY:

X4.2.1 Delivery date of completed representative unit: 45 Calendar Days After
Receipt of Purchase Agreement

X4.2.2 Delivery date of balance of completed units: 120 Calendar Days After Receipt of
Purchase Agreement

The "Bidder's Evaluation Report" is available for download on Purchasing's Web site at
www.state.wv.us/admin/purchase

X5.0 AWARD CRITERIA;

X5.1	Prices for units:	1-10	\$46,900	per unit
		11 and over	\$46,900	per unit

X6.0 SPECIFICATIONS - GENERAL

X6.1 Manufacturer, model, series, and date of manufacture of proposed unit:

BROCE RCT-350 2009 and later as ordered

Is descriptive literature, fully describing proposed unit attached to your bid? YES NO

If not, why? _____

X6.2 Will the required number of service manuals, and complete parts list be delivered to the Equipment Division at Buckhannon upon completion of delivery of total units?

YES NO

Will the required Equipment Preventive Maintenance Form (Section X6.2 of Bidders Evaluation Report) be provided upon inspection of the pilot unit? YES NO

X6.2
2-10-00

EQUIPMENT PREVENTATIVE MAINTENANCE QUESTIONNAIRE

THIS FORM MUST BE COMPLETED IN ITS ENTIRETY BY SUCCESSFUL BIDDER OR MANUFACTURER'S TECHNICAL REPRESENTATIVE PRIOR TO DELIVERY OF PILOT MODEL TO THE WVD0H.

DESCRIPTION: _____ MAKE: _____

MODEL: _____ YEAR: _____ PURCHASE AMOUNT: _____

ENGINE: MAKE: _____ MODEL: _____ FUEL TYPE: _____

HORSEPOWER: _____ CYLINDER: _____ ENGINE SERIAL: _____

COOLING SYSTEM CAPACITY: _____

BELTS: DESCRIPTION: _____ PART NUMBERS: _____

GVW: _____ AXLE CAPACITY: FRONT: _____ REAR: _____

TIRES: FRONT MAKE & SIZE: _____

REAR MAKE & SIZE: _____

DIMENSIONS OF UNIT: LENGTH: _____ WIDTH: _____ LENGTH: _____

VENDOR CONTACT PERSON: _____ PHONE: _____

PARTS:

BATTERY MAKE: _____ MODEL: _____ CCA: _____

TOP OR SIDE POST: _____ DIMENSIONS: LENGTH _____ WIDTH _____ HEIGHT _____

SPARK PLUGS OR FUEL INJECTORS MAKE: _____ PART #: _____

FUEL PUMP OR INJECTION PUMP MAKE: _____ MODEL: _____

ALTERNATOR MAKE: _____ PART #: _____

STARTER MAKE: _____ PART #: _____

TURBO CHARGER MAKE: _____ PART #: _____

TRANS. MAKE: _____ MODEL: _____ AUTO/MANUAL: _____

HYDRAULIC PUMP MAKE: _____ MODEL: _____

FILTERS	MAKE	PART NO.	LUBRICANT	MANUFACTURER TYPE
OIL	_____	_____	ENGINE	_____
AIR INNER	_____	_____	TRANSMISSION	_____
AIR OUTER	_____	_____	POWER STEERING	_____
FUEL PRIMARY	_____	_____	HYDRAULIC	_____
FUEL SECONDARY	_____	_____	DIFFERENTIALS	_____
COOLANT	_____	_____	BRAKE FLUID	_____
HYDRAULIC	_____	_____	COOLANT	_____
OTHER	_____	_____	OTHER	_____

X6.3 TRAINING:

Will training seminar be conducted on Preventive Maintenance, Operator and Mechanic Training YES NO

Will you conduct training with each purchase order against this open end contract? YES NO

Will training be conducted within 2 working days from the delivery of the pilot unit on the individual purchase order? YES NO

If NO, explain time frame _____

Will an Operator's Manual be furnished directly to Training Academy prior to the delivery of the pilot? YES NO

X6.4 If you are the successful vendor, will you furnish all training aids, i.e., videos, projectors, required in conducting the training? YES NO

X6.4.1 Will all manuals, booklets, etc. explaining preventive maintenance, operator procedures, and service schedule be delivered with each unit? YES NO
If NO, explain _____

X6.5 WARRANTY AND SERVICE POLICY

Will the warranty and service you provide comply with all areas as stated in Section 6.5 of specifications YES NO

Is warranty literature attached? YES NO

Is a minimum two (2) year bumper to bumper basic parts and labor warranty excluding abuse and normal wear items included? YES NO

Describe:

Two years bumper to bumper parts and labor

X6.5 WARRANTY AND SERVICE POLICY QUESTIONNAIRE

THIS FORM MUST BE COMPLETED IN ITS ENTIRETY AND SUBMITTED WITH YOUR BID.
(If additional lines are needed, make copies of form.)

1. Define the terms of the standard warranty. If not offered, so state. (Attach copy)

Standard warranty of one year has been extended to
two years bumper to bumper parts and labor

2. Define warranty service to be performed at DOH facilities and warranty service to be performed at manufacturer's representative facility. List name and location of manufacturer's representative.

Most work under warranty to be performed at West Virginia
Tractor Company in Charleston

3. List locations for parts inventories that are within the State of West Virginia. Also, list availability levels, if known.

West Virginia Tractor Company in Charleston will be

the source of parts for Broce products. Cummins engine parts are
available in South Charleston, Fairmont and many other locations.

4. During the term of warranty, list the guarantee discount to manufacturer's published list price for parts that bidder will sell the parts to owner.

A.	Terms: Net 30	Manufacturer's published list price less: <u> - </u> % discount
B.	Terms: Net 60	Manufacturer's published list price less: <u> - </u> % discount
C.	Terms: Net 90	Manufacturer's published list price less: <u> - </u> % discount

5. During the term of warranty, will all manufacturers or engineering improvements be submitted to Division of Highways? x YES NO

6. During the term of warranty, list the guaranteed rates charged for repair to the unit.

A. Shop Rate \$ 75.00 per mechanic hour

B. Travel Time Charge \$ 75.00 per mechanic hour
(Specify if one-way) _____; port to port x

C. Mileage Charge \$ 2.00 per vehicle mile
(Specify if one-way) _____; port to port x

D. Field Mechanic Rate \$ 75.00 per mechanic hour

E. Specify period of time that prices are in effect: One year

F. Surcharge for miscellaneous items: 150%
holidays and overtime

X6.6 EVALUATION COMMITTEE REQUIREMENTS

Is all component specifications, product literature, component models provided for Evaluation Committee bid determination? YES NO

X6.7 Will all parts, equipment, accessories, material, design and performance characteristics not specified herein, but which are necessary to provide a complete unit, be furnished with the unit and conform in strength, quality of material, and quality of workmanship to those which are advertised and provided to the market in general by the unit industry?

YES NO

X6.7.1 Are all parts and accessories adequate and regularly supplied as standard to be included except those which may be duplications of specifications herein, and except these by specification are not to be furnished?

YES NO

X6.7.2 Are all standard safety features that are required by Federal and State statutes of law included?

YES NO

X7.0 SPECIFICATIONS OF THE QUOTED UNIT:

The bidder should complete the following schedule in order for the Division to compare the actual bid unit to the specifications. Should the bidder except a requirement, then such exception may be only on the basis that such feature is not offered by the manufacturer. The Division will have the sole discretion as to whether the bidder's substitution meets the requirements of the specification.

Manufacturer: Broce Manufacturing Model: RCT-350

It is the intent to describe a self-propelled road sweeper in sufficient detail. Are all parts not specifically mentioned which are necessary to provide a complete sweeper included. YES NO

X7.1 Engine:

X7.1.1 Is engine rear mounted? YES NO

X7.1.2 Is engine diesel type? YES NO
Specify engine horsepower Cummins 3.3L 85 HP

X7.1.3 Is engine air filtration system Manufacturer's heaviest duty system offered? YES NO

X7.1.4 Will unit have manufacturers heaviest duty 12 volt electrical system? YES NO

X7.1.5 Is engine completely covered with hinged solid metal cover and lockable? YES NO

X7.2 Transmission:

X7.2.1 Will transmission be fully hydrostatic? YES NO
 Speeds infinitely variable from 0 to 34 MPH

X7.2.2 Will foot control provided be forward and reverse, spring loaded to return to neutral position? YES NO

X7.2.3 Is transmission 2 speed with a neutral position for towing or rear hub locked? YES NO
 If not specify _____

X7.3 Steering:

X7.3.1 Will unit be power steering YES NO

X7.4 Brakes:

X7.4.1 Does braking system include an operators pedal (service brake) for better operator control and safety YES NO

X7.4.2 Does braking system include a parking brake for additional safety YES NO

X7.5 Towing:

X7.5.1 Can machine be towed without disassembly of any parts? YES NO

X7.6 Brush:

X7.6.1 Does brush have heavy duty shock absorber for balance to take bounce out while sweeping? YES NO

X7.6.2 Will brush be powered by hydraulic motor independent of travel speed with direct drive motor located inside brush core? YES NO

X7.6.3 Is unit capable of sweeping angles? YES NO
 Specify 45 degrees left 45 degrees right

X7.6.4 Will brush control be conveniently located to include stop, rotation, raise, lower, float/lock in any desired position? YES NO

X7.6.5 Does brush have poly/steel sections? YES NO
Length: 8 feet **Diameter:** 32 inches

X7.6.6 Will a cover over brush be provided w/a rubber apron for rock protection? YES NO
140 degrees brush coverage

X7.6.7 Will brush be mid-mounted on unit under cab? YES NO

- X7.6.8 Does brush have a lock position for towing? YES NO
- X7.6.9 Will a governing device be provided in hydraulic system to control broom speed independently of carriage speed? YES NO
- X7.7. Hydraulic System:
- X7.7.1 Does unit have a hydraulic oil cooler? YES NO
- X7.7.2 Does hydraulic system have sufficient oil capacity to operate at maximum efficiency within manufacturer's recommended operating temperature? YES NO
- X7.7.3 Will minimum of two (2) 10 micron filters be provided at suction and return sections of system? YES NO
- X7.7.4 Will shut-off valves be provided for changing of filters if needed? YES NO
- X7.7.5 Is a sight glass incorporated in system for visual inspection of hydraulic oil? YES NO
- X7.8 Cab and Accessories:
- X7.8.1 Will cab be ROPS enclosed with sound deadening feature? YES NO
- X7.8.2 Does cab have right and left side lockable doors (keyed alike)? YES NO
- X7.8.3 Will tinted safety glass be provided? YES NO
- X7.8.4 Will front and rear wipers and washers be provided? YES NO
- X7.8.5 Does unit have a deluxe suspension seat with armrest? YES NO
- X7.8.6 Does unit have right, left and inside rear view mirrors? YES NO
- X7.8.7 Will cab be equipped with pressurized AC and heater with filter system? YES NO
- X7.8.8 Does unit have a mini light bar (Whelen PT#C200A000 or equal) mounted on cab? YES NO
- X7.8.9 Will unit have work lights front and rear with stop/tail and turn signals? YES NO
- X7.8.10 Will fenders be provided over all four (4) wheels? YES NO
- X7.9 Gauges to be provided:
- X7.9.1 Will unit have Voltmeter/Ammeter? YES NO
- X7.9.2 Will unit have engine oil pressure gauge? YES NO

- X7.9.3 Will unit have engine water temperature gauge? YES NO
- X7.9.4 Will unit have Hydraulic Oil temperature gauge? YES NO
- X7.9.5 Will unit have hourmeter? YES NO
- X7.10 Will unit have tilt and telescoping steering wheel? YES NO
- X7.11 Will unit be equipped with manufacturers vandalism protection? YES NO
- X7.12. Will same wheel and tire fit all four (4) wheels? YES NO
- X7.13 Sprinkler System:
- X7.13.1 Will sweeper have a water reservoir?
Specify 150 U.S. gallons YES NO
- X7.13.2 Will galvanized or rust proof piping be provided
Number of nozzles on spray bar: 8 YES NO
- X7.13.3 Will an electric pump be incorporated in system? YES NO
- X7.13.4 Will a 100 mesh strainer be provided in water system? YES NO
- X7.13.5 Will tank be polyethylene with vented filler cap? YES NO
- X7.13.6 Does unit have a back-flow valve preventing drainage when not in use? YES NO
- X7.13.7 Will a drain plug be provided on tank? YES NO
- X7.14 Will unit be provided with all manufacturers recommend safety related decals and safety features intact?** YES NO
- X7.15 Paint:
- X7.15.1 Will entire unit be painted manufacturers standard color(s)? YES NO
- X7.15.2 Will entire unit be thoroughly cleaned/free from grease, rust and scale?** YES NO
- X7.16 Will unit meet all OSHA and subsequent amendments requirement?** YES NO
- X7.17 Will advertising meet requirements as specified? YES NO

VENDOR PREFERENCE CERTIFICATE

Certification and application* is hereby made for Preference in accordance with West Virginia Code, §5A-3-37. (Does not apply to construction contracts). West Virginia Code, §5A-3-37, provides an opportunity for qualifying vendors to request (at the time of bid) preference for their residency status. Such preference is an evaluation method only and will be applied only to the cost bid in accordance with the West Virginia Code. This certificate for application is to be used to request such preference. The Purchasing Division will make the determination of the Resident Vendor Preference, if applicable.

- 1. Application is made for 2.5% resident vendor preference for the reason checked: Bidder is an individual resident vendor and has resided continuously in West Virginia for four (4) years immediately preceding the date of this certification; or, [X] Bidder is a partnership, association or corporation resident vendor and has maintained its headquarters or principal place of business continuously in West Virginia for four (4) years immediately preceding the date of this certification; or 80% of the ownership interest of Bidder is held by another individual, partnership, association or corporation resident vendor who has maintained its headquarters or principal place of business continuously in West Virginia for four (4) years immediately preceding the date of this certification; or, Bidder is a nonresident vendor which has an affiliate or subsidiary which employs a minimum of one hundred state residents and which has maintained its headquarters or principal place of business within West Virginia continuously for the four (4) years immediately preceding the date of this certification; or,
2. Application is made for 2.5% resident vendor preference for the reason checked: [X] Bidder is a resident vendor who certifies that, during the life of the contract, on average at least 75% of the employees working on the project being bid are residents of West Virginia who have resided in the state continuously for the two years immediately preceding submission of this bid; or,
3. Application is made for 2.5% resident vendor preference for the reason checked: Bidder is a nonresident vendor employing a minimum of one hundred state residents or is a nonresident vendor with an affiliate or subsidiary which maintains its headquarters or principal place of business within West Virginia employing a minimum of one hundred state residents who certifies that, during the life of the contract, on average at least 75% of the employees or Bidder's affiliate's or subsidiary's employees are residents of West Virginia who have resided in the state continuously for the two years immediately preceding submission of this bid; or,
4. Application is made for 5% resident vendor preference for the reason checked: [X] Bidder meets either the requirement of both subdivisions (1) and (2) or subdivision (1) and (3) as stated above; or,
5. Application is made for 3.5% resident vendor preference who is a veteran for the reason checked: Bidder is an individual resident vendor who is a veteran of the United States armed forces, the reserves or the National Guard and has resided in West Virginia continuously for the four years immediately preceding the date on which the bid is submitted; or,
6. Application is made for 3.5% resident vendor preference who is a veteran for the reason checked: [X] Bidder is a resident vendor who is a veteran of the United States armed forces, the reserves or the National Guard, if, for purposes of producing or distributing the commodities or completing the project which is the subject of the vendor's bid and continuously over the entire term of the project, on average at least seventy-five percent of the vendor's employees are residents of West Virginia who have resided in the state continuously for the two immediately preceding years.

Bidder understands if the Secretary of Revenue determines that a Bidder receiving preference has failed to continue to meet the requirements for such preference, the Secretary may order the Director of Purchasing to: (a) reject the bid; or (b) assess a penalty against such Bidder in an amount not to exceed 5% of the bid amount and that such penalty will be paid to the contracting agency or deducted from any unpaid balance on the contract or purchase order.

By submission of this certificate, Bidder agrees to disclose any reasonably requested information to the Purchasing Division and authorizes the Department of Revenue to disclose to the Director of Purchasing appropriate information verifying that Bidder has paid the required business taxes, provided that such information does not contain the amounts of taxes paid nor any other information deemed by the Tax Commissioner to be confidential.

Under penalty of law for false swearing (West Virginia Code, §61-5-3), Bidder hereby certifies that this certificate is true and accurate in all respects; and that if a contract is issued to Bidder and if anything contained within this certificate changes during the term of the contract, Bidder will notify the Purchasing Division in writing immediately.

Bidder: West Virginia Tractor Company Signed: [Signature]

Date: 1/5/09 Title: President

*Check any combination of preference consideration(s) indicated above, which you are entitled to receive.

STATE OF WEST VIRGINIA
Purchasing Division**PURCHASING AFFIDAVIT****VENDOR OWING A DEBT TO THE STATE:**

West Virginia Code §5A-3-10a provides that: No contract or renewal of any contract may be awarded by the state or any of its political subdivisions to any vendor or prospective vendor when the vendor or prospective vendor or a related party to the vendor or prospective vendor is a debtor and the debt owed is an amount greater than one thousand dollars in the aggregate.

PUBLIC IMPROVEMENT CONTRACTS & DRUG-FREE WORKPLACE ACT:

West Virginia Code §21-1D-5 provides that: Any solicitation for a public improvement construction contract shall require each vendor that submits a bid for the work to submit at the same time an affidavit that the vendor has a written plan for a drug-free workplace policy in compliance with Article 1D, Chapter 21 of the West Virginia Code. A public improvement construction contract may not be awarded to a vendor who does not have a written plan for a drug-free workplace policy in compliance with Article 1D, Chapter 21 of the West Virginia Code and who has not submitted that plan to the appropriate contracting authority in timely fashion. For a vendor who is a subcontractor, compliance with Section 5, Article 1D, Chapter 21 of the West Virginia Code may take place before their work on the public improvement is begun.

ANTITRUST:

In submitting a bid to any agency for the state of West Virginia, the bidder offers and agrees that if the bid is accepted the bidder will convey, sell, assign or transfer to the state of West Virginia all rights, title and interest in and to all causes of action it may now or hereafter acquire under the antitrust laws of the United States and the state of West Virginia for price fixing and/or unreasonable restraints of trade relating to the particular commodities or services purchased or acquired by the state of West Virginia. Such assignment shall be made and become effective at the time the purchasing agency tenders the initial payment to the bidder.

I certify that this bid is made without prior understanding, agreement, or connection with any corporation, firm, limited liability company, partnership or person or entity submitting a bid for the same materials, supplies, equipment or services and is in all respects fair and without collusion or fraud. I further certify that I am authorized to sign the certification on behalf of the bidder or this bid.

LICENSING:

Vendors must be licensed and in good standing in accordance with any and all state and local laws and requirements by any state or local agency of West Virginia, including, but not limited to, the West Virginia Secretary of State's Office, the West Virginia Tax Department, West Virginia Insurance Commission, or any other state agencies or political subdivision. Furthermore, the vendor must provide all necessary releases to obtain information to enable the Director or spending unit to verify that the vendor is licensed and in good standing with the above entities.

CONFIDENTIALITY:

The vendor agrees that he or she will not disclose to anyone, directly or indirectly, any such personally identifiable information or other confidential information gained from the agency, unless the individual who is the subject of the information consents to the disclosure in writing or the disclosure is made pursuant to the agency's policies, procedures and rules. Vendors should visit www.state.wv.us/admin/purchase/privacy for the Notice of Agency Confidentiality Policies.

Under penalty of law for false swearing (West Virginia Code §61-5-3), it is hereby certified that the vendor acknowledges the information in this said affidavit and is in compliance with the requirements as stated.

Vendor's Name: West Virginia Tractor Company

Authorized Signature: _____

Date: _____

1/5/09

WEST VIRGINIA TRACTOR COMPANY

709EC009 Exceptions to Specifications

- 7.0 GENERAL SPECIFICATIONS: The specified unit is a three wheel style self propelled broom with a 33 HP diesel engine. The Broce RCT-350 self propelled broom we are offering is a full size four wheel style self propelled broom with a 85 HP Cummins diesel engine, 150 gallon water tank, full size cab with a conventional style air conditioner driven by the engine and other components that greatly exceed your specifications.

BROCE MANUFACTURING COMPANY

BROCE BROOM LIMITED TWELVE MONTH WARRANTY

STANDARD WARRANTY FORM EXTENDED TO 24 MONTHS

For a period of twelve (12) months or 1,000 hours whichever comes first, from the date of delivery of product to the original user, Broce Manufacturing of Dodge City, Kansas warrants each product to be free from manufacturing defects, subject to the limitations contained in this policy. This limited warranty covers parts and labor.

This warranty does not apply to defect caused, in whole or in part, by unreasonable use while in the possession of the user, including, but not limited to, failure to properly set up product, failure to provide reasonable and necessary maintenance, normal wear, routine tune ups or adjustments, improper handling, accidents, operation at speed or load conditions contrary to published specifications, improper or insufficient lubrication, or improper storage. This warranty is not a guarantee that the performance of each product will meet the expectations of the purchaser.

Broce Manufacturing shall not be liable for consequential damage of any kind, including, but not limited to: consequential labor costs or transportation charges in connection with the replacement or repair of defective parts, lost time or expense which may have accrued because of said defects. In no event shall Broce Manufacturing's total liability hereunder exceed the product purchase price.

Many components used by Broce Manufacturing are subject to the warranties of their respective manufacturers. These warranties will be considered void if the product is modified or repaired in any way not expressly authorized, or if closed components are disassembled prior to return. Closed components include, but are not limited to gearboxes, hydraulic pumps, motors, cylinders and actuators.

Our obligation under the warranty is expressly limited, at our option, to the replacement or repair at Broce Manufacturing of Dodge City, KS or at a service facility designated by us. We are not responsible for unauthorized repairs or replacements. Any implied or statutory warranties, including any warranty of merchantability or fitness for a particular purpose, are expressly limited to duration of this written warranty. We make no other express warranty. This warranty cannot be extended, broadened, or changed except in writing by an authorized officer of Broce Manufacturing.

WEST VIRGINIA TRACTOR COMPANY

COMPLIANCE WITH WEST VIRGINIA PURCHASING RULES

As required by law and West Virginia Department of Administration, Purchasing Division Legislative Rule 148 CSR 1, West Virginia Tractor Company is licensed and in good standing with any and all state and local laws and requirements, including the West Virginia Secretary of State's office, the West Virginia Tax Department, the West Virginia Insurance Commission, or any other state agencies or political subdivisions, including the West Virginia Division of Motor Vehicles as a trailer dealer (DTR-1594) and as a new vehicle dealer (D-43).

West Virginia Code 5A-3-10a. Prohibition for awarding contracts to vendors which owe a debt to the state or its political subdivisions, stipulates that this applies to contracts or renewal of contracts to be awarded by the state or any of its political subdivisions, which includes counties and municipalities.

West Virginia Tractor Company does not discriminate against any employee or applicant for employment because of race, religion, color, sex, handicap, or national origin.

40 YEARS OF SERVICE TO THE INDUSTRY

Broce Broom

THE  LEADER



Visit our web site at
www.brocebroom.com



CR-350



RJ-350



RC-350

CALL TOLL FREE
866-579-2488 - Sales
877-227-8811 - Service

ASK YOUR
NEAREST BROCE
DEALER FOR A
DEMONSTRATION
TODAY!

OPTIONAL CURB SWEEPER

**CLEANS IN PLACES
THAT ARE TOUGH
TO REACH**

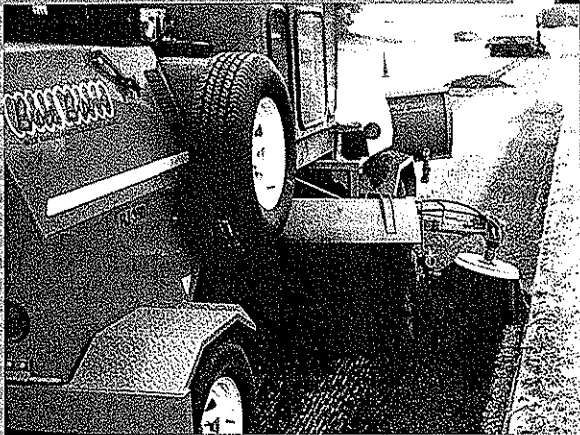

EASY TO OPERATE WITH CONTROLS AT OPERATOR'S STATION

The Broce Curb Sweeper is a special option available on all 4-wheel model Broce Brooms. This attachment has been designed to help clean in places that are tough to reach and are outside the sweeping radius of the main broom core. The Broce Curb Sweeper features a 27" diameter brush, heavy-duty construction, a reversible hydraulic motor and hydraulically operated float and down pressure for heavy sweeping.

WATER SPRAY SYSTEMS DUST CONTROL WHEN YOU NEED IT

KEEP THE DUST TO A MINI- MUM FOR CONVENIENCE AND SAFETY

Our 150 gallon rust proof water spray system consists of a low profile polyethylene tank, 2.5 gpm electric pump, strainer filter and 8 spray nozzles to control excessive dust with the push of a button. This system also includes a back flow valve to prevent tank drainage when not in use.

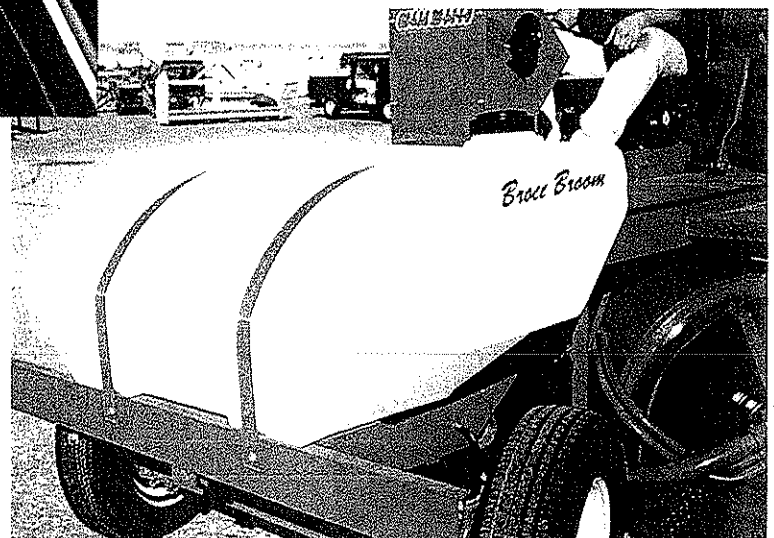
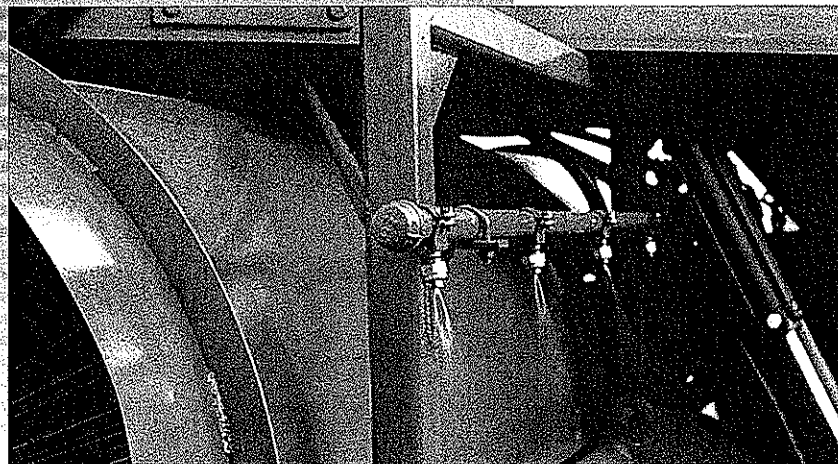

OPTIONAL 7 1/2 FOOT SCRAPER BLADE

When heavy material
buildup is a problem, the Broce
Scraper Blade is a must!

DESIGNED FOR HEAVY MATERIAL REMOVAL WHILE SWEEPING

The operator's station gives you clear
unobstructed view of the scraper blade through
the full glass front windshield.

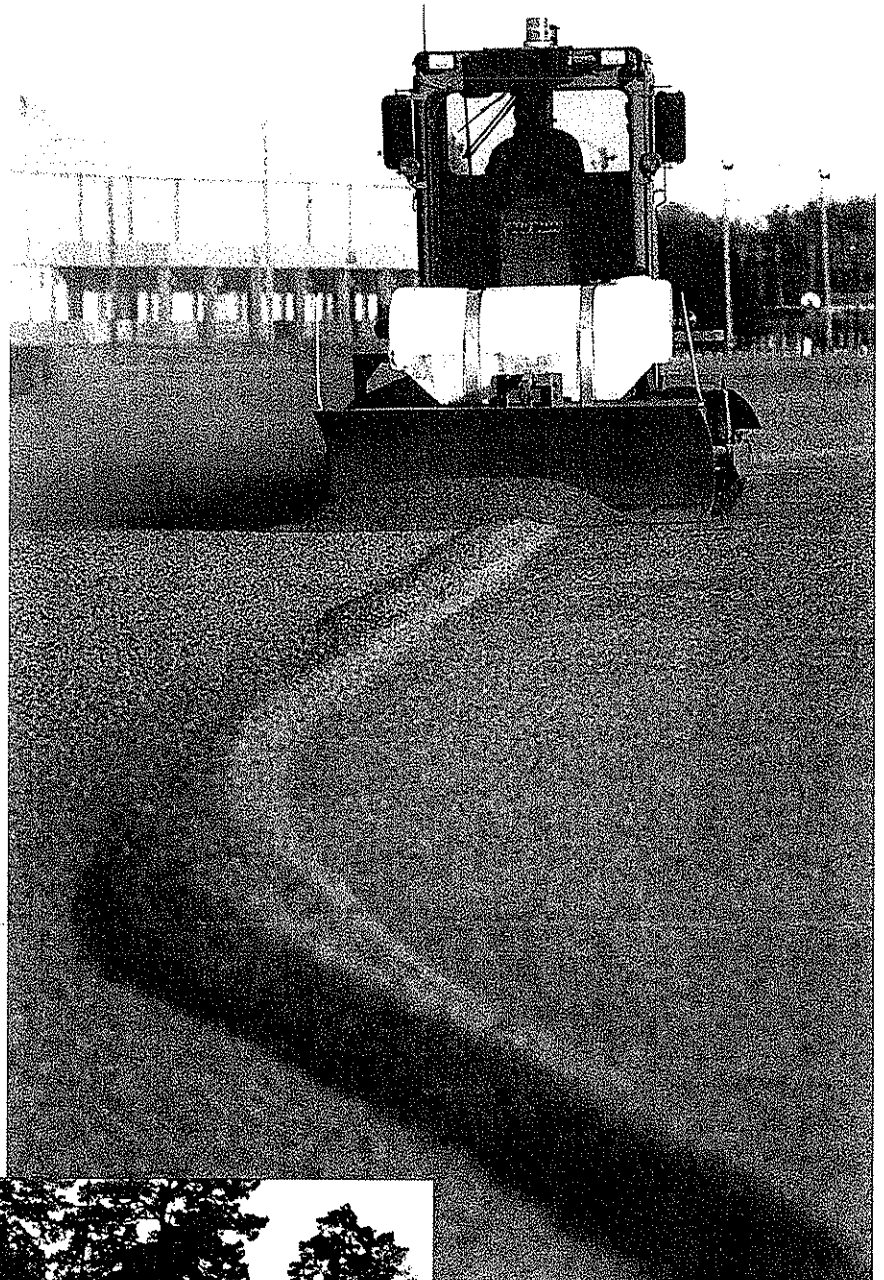

USE THE BLADE FOR CLEANING BEHIND YOUR MILLING MACHINE OR CHIP AND SEAL JOBS

The blade will hydraulically lift
vertically for clearance and angle right
to left with a control located at
operator's station. A quick coupling
allows the blade to be removed when
not in use. The replaceable cutting
edge will give hours of continued use.

SOUND SUPPRESSED CAB DESIGNED FOR MAXIMUM COMFORT & VISIBILITY

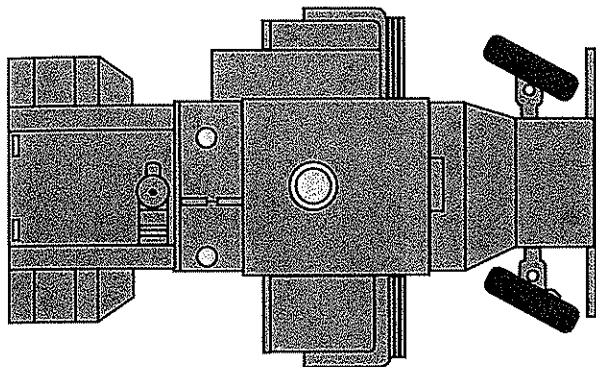

13 1/2 Foot
Turning Radius

With our compact wheel base, the Broce Broom offers better maneuverability for working in tight places.

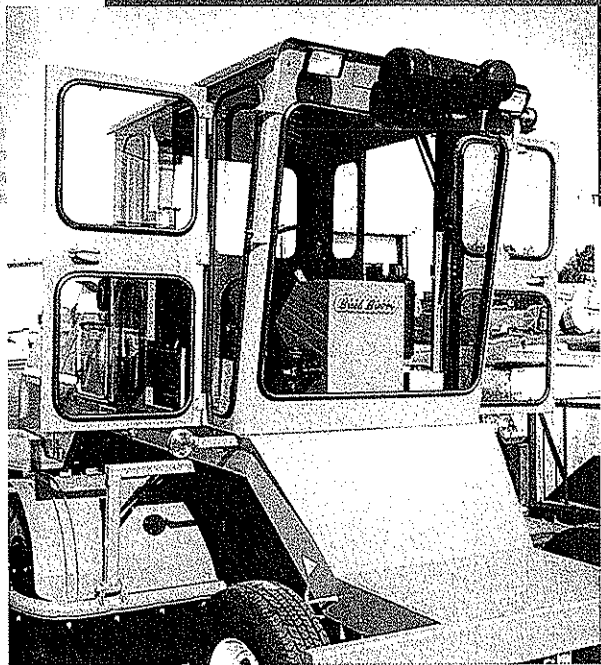

The new enclosed cab offers two doors with gas shocks, tinted safety glass, front windshield wiper, padded floor mat, and great visibility.

DIRECT DRIVE CORE MOTOR

Broce uses a Danfoss heavy duty high torque motor with two roller bearings designed for high side loads. The side load capacity eliminates the need for outboard bearings.

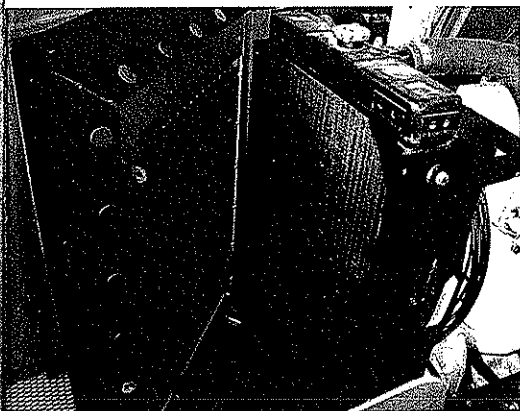

SWING OUT OIL COOLER

Is standard equipment on all Broce Brooms for easy cleaning and better cooling.

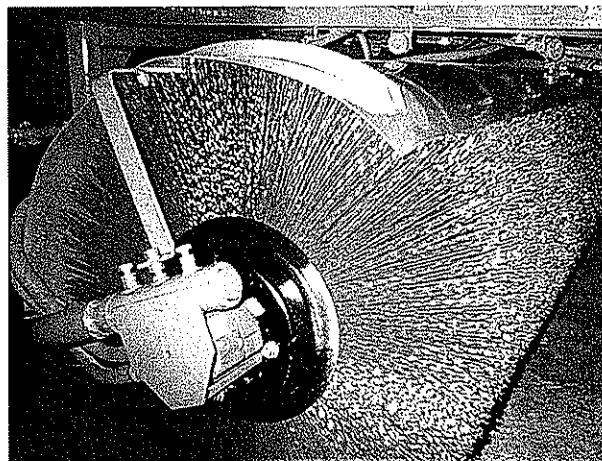

ENGINE OPTIONS & EASE OF MAINTENANCE

The enclosed engine cover is standard equipment on all Broce Brooms. With John Deere, Cummins and Caterpillar diesel engines to choose from, we can meet your power unit requirements.

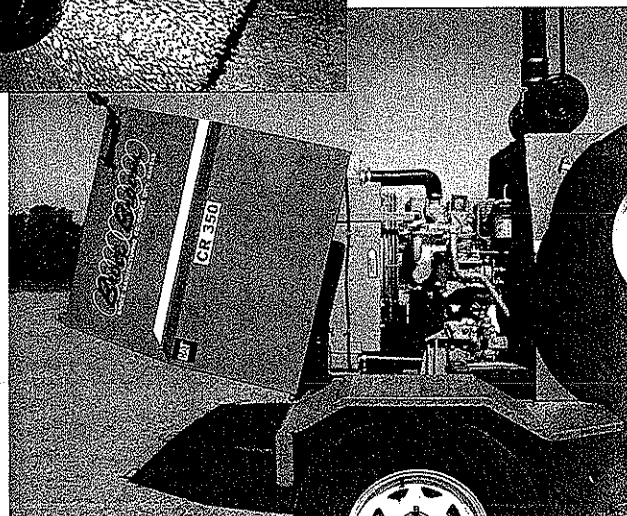

BROCE BROOM HYDROSTATIC DRIVE SPECIFICATIONS

Standard Equipment Specs

- Certified Roll Over Structure and Canopy
- Main Frame - All Welded 6" Channel
- Heavy Structural Steel with Gussets at Stress Points
- 6" Rectangular Tubing - Front and Rear Bumpers
- Front Fenders are standard equipment
- Weight (standard unit) - 5,000 lbs.
- Overall Length - 170 inches
- Overall Width for Transport - 96 inches
- Overall Height - 100 inches
- Inside Turning Radius - 13.5 feet
- Brakes - Equipped with 4-wheel self-adjusting Hydraulic with Mechanical Parking Brake and Dual Master Cylinder
- Brush Core - 8' all Steel Welded Construction
- Brush Filler - 10" x 32" Wafers - Prostran
- Sweeping Width - 90" Standard, 96" Optional
- Brush Drive - Direct Drive Motor enclosed in Core, 190 RPM
- Core Cover - 140 degrees 16 Gauge Steel with Rock Deflector
- Swing Frame - Mounted on 9 Heavy Duty Sealed Ball Bearings
- Sweeping Angle - 45 degrees Left or Right
- Broom Controls - Single Lever Joystick Control Valve w/Adjustable Down Pressure and Float Position
- Hydraulic Tank Capacity - 21 US Gallons w/100 Mesh Suction Strainer
- Operating Pressure - 3,000 PSI
- Pump Capacity - 26 GPM at 2600 RPM
- Filter - Two 10 Micron Replaceable Element (suction and return)
- Fuel Capacity - 21 US Gallons
- Front Axle - Heavy Duty Oscillating w/Drum Brakes
- Rear Axle - Dana Heavy Duty Truck Type w/Drum Brakes
- Wheels - 15 x 6 - 5 Bolt Steel Wheels
- Tires - P235/75 R15 Load Range C Radials
- Steering - Orbital Type Power Steering
- Padded Seat with Arm Rests and Seat Belt
- Instruments and Controls - Water Temperature, Oil Pressure, Volt Meter, Tachometer, Hour Meter, Fuel Gauge, Reverse Alarm, Rear View Mirror, Controls for Broom Drive, Core Angling, Core Height, Electric Core Lock, Engine Throttle, Brakes, Directional Control, Parking Brake with Engaging Light, Traffic Horn
- Transmission - Sauer-Danfoss Hydrostatic Pump and Motor coupled to a 2-Speed Gearbox with Neutral Shift for Towing. Low Gear 13 MPH, High Gear 34 MPH
- Air Cleaner - Donaldson Dual Element Type with Precleaner
- Engine Options: Model
RC-350: 239 CID Cummins Diesel, 4 Cyl., 80 HP at 2500 RPM
RJ-350: 276 CID John Deere Diesel, 4 Cyl., 80 HP at 2500 RPM
CR-350: 258 CID Caterpillar Diesel, 4 Cyl., 86 HP at 2500 RPM

Optional Equipment

- 150 Gallon Water Sprinkling System w/Poly Tank
- Tilt & Telescoping Steering
- 7 1/2 Ft. Scraper Blade
- Canopy Windshield
- Light Group
- Work Lights - Side or Rear
- Amber Beacon or Strobe Light
- Turbo II Precleaner or Sy-Klone
- Extension Air Cleaner Stack
- Spare Tire with Mount
- Tire Options
- Enclosed Cab with Safety Glass and Wiper
- Cab Heater and Defroster Fan
- Pressurized Air Conditioning
- Rear Windshield Wiper
- Windshield Washer - Front or Rear
- Hydraulic Temperature Gauge
- Tow Hitch with Safety Chains - Surge Brake Available
- Suspension Seat
- Audible Engine Alarm System
- 96" Poly Tube Broom
- Hydrostatic Hand Control
- 35 Gallon Fuel Tank
- 3/4 Ton Heavy Duty Rear Axle
- Curb and Gutter Brush
- Safety Engine Shut Down System
- Block Heater
- AM/FM Stereo Package
- Vari-Speed Brush

Distributed by:

Broce Broom

Broce Manufacturing Co. • 205 E. Main • Norman, OK 73069-1304
Sales: 866-579-2488 • Service: 877-227-8811

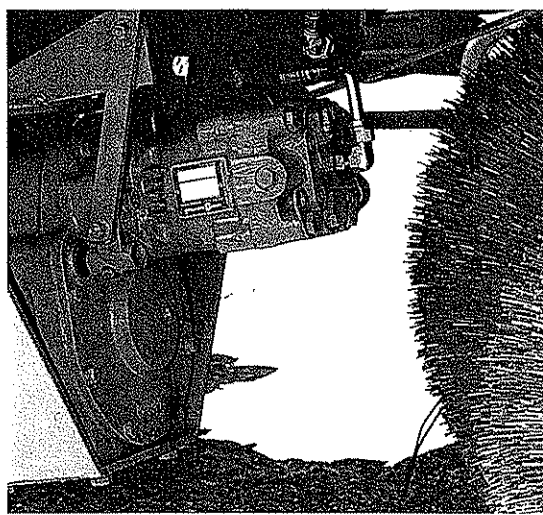

HYDROSTATIC DRIVE WITH 2 SPEED GEAR BOX

All Broce Brooms are supplied with our unique hydrostatic drive train with a hot oil shuttle built into the drive motor for continuous oil flow back to the cooler.

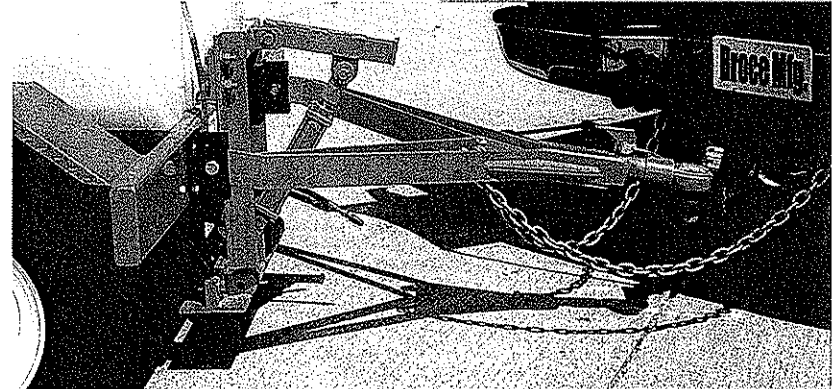

THE BROCE HYDROSTATIC SWEEPER CAN BE TOWED TO JOB SIGHTS

The two speed gearbox allows the operator to adjust road speed for optimum performance while sweeping or traveling. Neutral shift for towing at highway speed is standard equipment.

**TOW BARS
COMPETITIVE
MODELS NEED
TO BE HAULED**

OPTIONAL

Suspension seat.



STANDARD

Instrument panel and gauges are standard equipment.

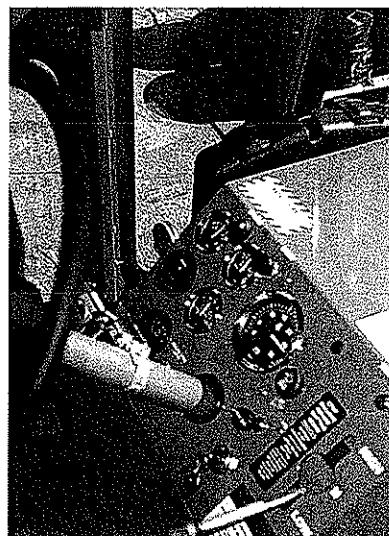

EXCLUSIVE

Joystick broom control with easy access from operator's station.

