

FAX

UNIONTOWN INDUSTRIAL EQUIPMENT CO INC
 2266 University Drive
 Leimont Furnace PA. 15456
 (724) 437-1578
 FAX (724) 437-2098

TO: Purchasing Div. FROM: Mike Clower
 FAX #: 304-558-2063 FAX #: 724-437-2098
 DATE: 1/7/09 # OF PAGES: 40

MESSAGE:

RFQ # 709EC009

2009 JAN -7 A 8:41
 PURCHASING DIVISION
 STATE OF WV

RECEIVED



State of West Virginia
 Department of Administration
 Purchasing Division
 2019 Washington Street East
 Post Office Box 50130
 Charleston, WV 25305-0130

Request for Quotation

RFQ NUMBER
709EC009

PAGE
1

ADDRESS CORRESPONDENCE TO ATTENTION OF
**MICHAEL AUSTIN
 304-558-2402**

*709015804 724-437-1578
 UNIONTOWN INDUSTRIAL EQUIP CO
 2266 UNIVERSITY DR

LEMONT FURNACE PA 15478

DIVISION OF HIGHWAYS
 EQUIPMENT DIVISION
 ROUTE 33
 BRUSHY FORK ROAD
 BUCKHANNON, WV
 26201 304-472-1750

DATE PRINTED	TERMS OF SALE	SHIP VIA	F.O.B.	FREIGHT TERMS
12/02/2008				

BID OPENING DATE: **01/07/2009** BID OPENING TIME: **01:30PM**

LINE	QUANTITY	UOP	CAT NO	ITEM NUMBER	UNIT PRICE	AMOUNT
0001	1	EA		765-77	\$33,300.00	\$33,300.00
<p>SELF PROPELLED POWER BROOM</p> <p>OPEN END CONTRACT</p> <p>TO PROVIDE SELF PROPELLED POWER BROOM FOR THE WEST VIRGINIA DIVISION OF HIGHWAYS PER THE ATTACHED SPECIFICATIONS.</p> <p>A MANDATORY PRE-BID CONFERENCE WILL BE HELD ON 12/15/08 AT 10:00 AM, AT THE EQUIPMENT DIVISION, BUCKHANNON, WEST VIRGINIA. FAILURE TO ATTEND PRE-BID WILL RESULT IN BID DISQUALIFICATION.</p> <p>QUESTION: WRITTEN QUESTIONS WILL BE ACCEPTED THROUGH CLOSE OF BUSINESS (5:00 PM EST.) ON THURSDAY 12/11/08. SEND YOUR QUESTIONS TO: PURCHASING DIVISION ATTENTION MICHAEL AUSTIN 2019 WASHINGTON ST., EAST CHARLESTON, WV 25305</p> <p>QUESTIONS MAY BE SENT VIA FAX, E-MAIL, OR REGULAR MAIL. E-MAIL: MICHAEL.D.AUSTIN@WV.GOV FAX: 304-558-4115</p> <p>IT IS THE VENDORS RESPONSIBILITY TO VERIFY THAT THEIR QUESTIONS HAVE BEEN RECEIVED BY CALLING 304-558-2402.</p> <p>EXHIBIT 2</p> <p>LIFE OF CONTRACT: THIS CONTRACT BECOMES EFFECTIVE ON</p>						

SEE REVERSE SIDE FOR TERMS AND CONDITIONS

SIGNATURE <i>Michael D. Austin</i>	TELEPHONE (724) 437-1578	DATE 12/12/08
TITLE V. PRESIDENT	FAX 25-1389795	ADDRESS CHANGES TO BE NOTED ABOVE

WHEN RESPONDING TO RFQ, INSERT NAME AND ADDRESS IN SPACE ABOVE IF AN RFQ VENDOR

**GENERAL TERMS & CONDITIONS
REQUEST FOR QUOTATION (RFQ) AND REQUEST FOR PROPOSAL (RFP)**

1. Awards will be made in the best interest of the State of West Virginia.
2. The State may accept or reject in part, or in whole, any bid.
3. All quotations are governed by the *West Virginia Code* and the *Legislative Rules* of the Purchasing Division.
4. Prior to any award, the apparent successful vendor must be properly registered with the Purchasing Division and have paid the required \$125 fee.
5. All services performed or goods delivered under State Purchase Order/Contracts are to be continued for the term of the Purchase Order/Contracts, contingent upon funds being appropriated by the Legislature or otherwise being made available. In the event funds are not appropriated or otherwise available for these services or goods, this Purchase Order/Contract becomes void and of no effect after June 30.
6. Payment may only be made after the delivery and acceptance of goods or services.
7. Interest may be paid for late payment in accordance with the *West Virginia Code*.
8. Vendor preference will be granted upon written request in accordance with the *West Virginia Code*.
9. The State of West Virginia is exempt from federal and state taxes and will not pay or reimburse such taxes.
10. The Director of Purchasing may cancel any Purchase Order/Contract upon 30 days written notice to the seller.
11. The laws of the State of West Virginia and the *Legislative Rules* of the Purchasing Division shall govern all rights and duties under the Contract, including without limitation the validity of this Purchase Order/Contract.
12. Any reference to automatic renewal is hereby deleted. The Contract may be renewed only upon mutual written agreement of the parties.
13. **BANKRUPTCY:** In the event the vendor/contractor files for bankruptcy protection, this Contract may be deemed null and void, and terminated without further order.
14. **HIPAA BUSINESS ASSOCIATE ADDENDUM:** The West Virginia State Government HIPAA Business Associate Addendum (BAA), approved by the Attorney General, and available online at the Purchasing Division's web site (<http://www.state.wv.us/admin/purchase/vrc/hipaa.htm>) is hereby made part of the agreement. Provided that, the Agency meets the definition of a Cover Entity (45 CFR §160.103) and will be disclosing Protected Health Information (45 CFR §160.103) to the vendor.
15. **WEST VIRGINIA ALCOHOL & DRUG-FREE WORKPLACE ACT:** If this Contract constitutes a public improvement construction contract as set forth in Article 1D, Chapter 21 of the West Virginia Code ("The West Virginia Alcohol and Drug-Free Workplace Act"), then the following language shall hereby become part of this Contract: "The contractor and its subcontractors shall implement and maintain a written drug-free workplace policy in compliance with the West Virginia Alcohol and Drug-Free Workplace Act, as set forth in Article 1D, Chapter 21 of the West Virginia Code. The contractor and its subcontractors shall provide a sworn statement in writing, under the penalties of perjury, that they maintain a valid drug-free work place policy in compliance with the West Virginia and Drug-Free Workplace Act. It is understood and agreed that this Contract shall be cancelled by the awarding authority if the Contractor: 1) Fails to implement its drug-free workplace policy; 2) Fails to provide information regarding implementation of the contractor's drug-free workplace policy at the request of the public authority; or 3) Provides to the public authority false information regarding the contractor's drug-free workplace policy."

INSTRUCTIONS TO BIDDERS

1. Use the quotation forms provided by the Purchasing Division.
2. **SPECIFICATIONS:** Items offered must be in compliance with the specifications. Any deviation from the specifications must be clearly indicated by the bidder. Alternates offered by the bidder as **EQUAL** to the specifications must be clearly defined. A bidder offering an alternate should attach complete specifications and literature to the bid. The Purchasing Division may waive minor deviations to specifications.
3. Complete all sections of the quotation form.
4. Unit prices shall prevail in case of discrepancy.
5. All quotations are considered F.O.B. destination unless alternate shipping terms are clearly identified in the quotation.
6. **BID SUBMISSION:** All quotations must be delivered by the bidder to the office listed below prior to the date and time of the bid opening. Failure of the bidder to deliver the quotations on time will result in bid disqualifications: Department of Administration, Purchasing Division, 2019 Washington Street East, P.O. Box 50130, Charleston, WV 25305-0130



State of West Virginia
 Department of Administration
 Purchasing Division
 2019 Washington Street East
 Post Office Box 50130
 Charleston, WV 25305-0130

**Request for
 Quotation**

RFQ NUMBER
709EC009

PAGE
2

ADDRESS CORRESPONDENCE TO ATTENTION OF
MICHAEL AUSTIN 304-558-2402

*709015804 724-437-1578
 UNIONTOWN INDUSTRIAL EQUIP CO
 2266 UNIVERSITY DR
 LEMONT FURNACE PA 15478

DIVISION OF HIGHWAYS
 EQUIPMENT DIVISION
 ROUTE 33
 BRUSHY FORK ROAD
 BUCKHANNON, WV
 26201 304-472-1750

DATE PRINTED	TERMS OF SALE	SHIP VIA	FOB	FREIGHT TERMS
12/02/2008				

BID OPENING DATE: 01/07/2009 BID OPENING TIME 01:30PM

LINE	QUANTITY	UOP	CAT NO	ITEM NUMBER	UNIT PRICE	AMOUNT
<p>..... AND EXTENDS FOR A PERIOD OF ONE (1) YEAR OR UNTIL SUCH "REASONABLE TIME" THEREAFTER AS IS NECESSARY TO OBTAIN A NEW CONTRACT OR RENEW THE ORIGINAL CONTRACT. THE "REASONABLE TIME" PERIOD SHALL NOT EXCEED TWELVE (12) MONTHS. DURING THIS "REASONABLE TIME" THE VENDOR MAY TERMINATE THIS CONTRACT FOR ANY REASON UPON GIVING THE DIRECTOR OF PURCHASING THIRTY (30) DAYS WRITTEN NOTICE.</p> <p>UNLESS SPECIFIC PROVISIONS ARE STIPULATED IN THIS CONTRACT DOCUMENT, THE TERMS, CONDITIONS, AND PRICING SET HEREIN ARE FIRM FOR THE LIFE OF THE CONTRACT.</p> <p>RENEWAL: THIS CONTRACT MAY BE RENEWED UPON THE MUTUAL WRITTEN CONSENT OF THE SPENDING UNIT AND VENDOR, SUBMITTED TO THE DIRECTOR OF PURCHASING THIRTY (30) DAYS PRIOR TO THE EXPIRATION DATE. SUCH RENEWAL SHALL BE IN ACCORDANCE WITH THE TERMS AND CONDITIONS OF THE ORIGINAL CONTRACT AND SHALL BE LIMITED TO TWO (2) ONE (1) YEAR PERIODS.</p> <p>CANCELLATION: THE DIRECTOR OF PURCHASING RESERVES THE RIGHT TO CANCEL THIS CONTRACT IMMEDIATELY UPON WRITTEN NOTICE TO THE VENDOR IF THE COMMODITIES AND/OR SERVICE SUPPLIED ARE OF AN INFERIOR QUALITY OR DO NOT CONFORM WITH THE SPECIFICATIONS OF THE BID AND CONTRACT HEREIN.</p> <p>OPEN MARKET CLAUSE: THE DIRECTOR OF PURCHASING MAY AUTHORIZE A SPENDING UNIT TO PURCHASE ON THE OPEN MARKET, WITHOUT THE FILING OF A REQUISITION OR COST ESTIMATE, ITEMS SPECIFIED ON THIS CONTRACT FOR IMMEDIATE DELIVERY IN EMERGENCIES DUE TO UNFORESEEN CAUSES (INCLUDING BUT NOT LIMITED TO DELAYS IN TRANSPORTATION OR AN UNANTICIPATED INCREASE IN THE VOLUME OF WORK).</p> <p>QUANTITIES: QUANTITIES LISTED IN THE REQUISITION ARE</p>						

SIGNATURE				TELEPHONE		DATE	
<i>Michael D. Cline</i>				(724) 437-1578		12/12/08	
TITLE			FEIN		ADDRESS CHANGES TO BE NOTED ABOVE		
V. PRESIDENT			25-1389795				

WHEN RESPONDING TO RFQ, INSERT NAME AND ADDRESS IN SPACE ABOVE LABELED 'VENDOR'



State of West Virginia
 Department of Administration
 Purchasing Division
 2019 Washington Street East
 Post Office Box 50130
 Charleston, WV 25305-0130

Request for Quotation

RFQ NUMBER
709EC009

PAGE
3

ADDRESS CORRESPONDENCE TO ATTENTION OF
MICHAEL AUSTIN 304-558-2402

VENDOR

*709015804 724-437-1578
 UNIONTOWN INDUSTRIAL EQUIP CO
 2266 UNIVERSITY DR

LEMONT FURNACE PA 15478

SHIP TO

DIVISION OF HIGHWAYS
 EQUIPMENT DIVISION
 ROUTE 33
 BRUSHY FORK ROAD
 BUCKHANNON, WV
 26201 304-472-1750

DATE PRINTED	TERMS OF SALE	SHIP VIA	F.O.B.	FREIGHT TERMS
12/02/2008				

BID OPENING DATE:	01/07/2009	BID OPENING TIME	01:30PM
-------------------	------------	------------------	---------

LINE	QUANTITY	UOP	CAT NO	ITEM NUMBER	UNIT PRICE	AMOUNT
<p>APPROXIMATIONS ONLY, BASED ON ESTIMATES SUPPLIES BY THE STATE SPENDING UNIT. IT IS UNDERSTOOD AND AGREED THAT THE CONTRACT SHALL COVER THE QUANTITIES ACTUALLY ORDERED FOR DELIVERY DURING THE TERM OF CONTRACT, WHETHER MORE OR LESS THAN THE QUANTITIES SHOWN.</p> <p>ORDERING PROCEDURE: SPENDING UNIT(S) SHALL ISSUE A WRITTEN EQUIPMENT CONTRACT ORDER (FORM NUMBER WV-35) FOR COMMODITIES COVERED BY THIS CONTRACT. THE ORIGINAL WV-35 MUST BE SENT TO THE PURCHASING DIVISION OF THE DEPARTMENT OF ADMINISTRATION. AFTER APPROVAL AND ENCUMBRANCE, ONE COPY OF THE PURCHASE ORDER WILL BE RETURNED TO THE SPENDING UNIT AND ONE COPY FORWARDED TO THE VENDOR AS AUTHORIZATION FOR SHIPMENT. NO ORDER IS VALID UNLESS APPROVED AND ENCUMBERED BY THE PURCHASING DIVISION.</p> <p>BANKRUPTCY: IN THE EVENT THE VENDOR/CONTRACTOR FILES FOR BANKRUPTCY PROTECTION, THIS CONTRACT IS AUTOMATICALLY NULL AND VOID, AND IS TERMINATED WITHOUT FURTHER ORDER.</p> <p>EXHIBIT 4</p> <p>LOCAL GOVERNMENT BODIES: UNLESS THE VENDOR INDICATES IN THE BID HIS REFUSAL TO EXTEND THE PRICES, TERMS, AND CONDITIONS OF THE BID TO COUNTY, SCHOOL, MUNICIPAL AND OTHER LOCAL GOVERNMENT BODIES, THE BID SHALL EXTEND TO POLITICAL SUBDIVISIONS OF THE STATE OF WEST VIRGINIA. IF THE VENDOR DOES NOT WISH TO EXTEND THE PRICES, TERMS, AND CONDITIONS OF THE BID TO ALL POLITICAL SUBDIVISIONS OF THE STATE, THE VENDOR MUST CLEARLY INDICATE SUCH REFUSAL IN HIS BID. SUCH REFUSAL SHALL NOT PREJUDICE THE AWARD OF THIS CONTRACT IN ANY MANNER.</p>						

SIGNATURE	SEE REVERSE SIDE FOR TERMS AND CONDITIONS		TELEPHONE	DATE
<i>Michael Wilkins</i>			(724) 437-1578	12/12/08
TITLE	FAX	ADDRESS CHANGES TO BE NOTED ABOVE		
V. PRESIDENT	25-1389795			

WHEN RESPONDING TO RFQ, INSERT NAME AND ADDRESS IN SPACE ABOVE LABELED 'VENDOR'



State of West Virginia
 Department of Administration
 Purchasing Division
 2019 Washington Street East
 Post Office Box 50130
 Charleston, WV 25305-0130

**Request for
 Quotation**

RFQ NUMBER
709EC009

PAGE
4

ADDRESS CORRESPONDENCE TO ATTENTION OF
**MICHAEL AUSTIN
 304-558-2402**

VENDOR

*709015804 724-437-1578
 UNIONTOWN INDUSTRIAL EQUIP CO
 2266 UNIVERSITY DR
 LEMONT FURNACE PA 15478

SHIP TO

DIVISION OF HIGHWAYS
 EQUIPMENT DIVISION
 ROUTE 33
 BRUSHY FORK ROAD
 BUCKHANNON, WV
 26201 304-472-1750

DATE PRINTED	TERMS OF SALE	SHIP VIA	FOB	FREIGHT TERMS
12/02/2008				

BID OPENING DATE: **01/07/2009** BID OPENING TIME **01:30PM**

LINE	QUANTITY	UQP	CAT NO	ITEM NUMBER	UNIT PRICE	AMOUNT
	REV. 3/88					
	EXHIBIT 6					
	<p>PRICE ADJUSTMENT PROVISION: THE STATE OF WEST VIRGINIA WILL CONSIDER BIDS THAT CONTAIN PROVISIONS FOR PRICE ADJUSTMENTS PRIOR TO THE ORIGINAL EXPIRATION OF THE CONTRACT, PROVIDED THAT SUCH PRICE ADJUSTMENT COVERS BOTH UPWARD AND DOWNWARD MOVEMENT OF THE COMMODITY PRICE, AND THAT ADJUSTMENT IS BASED ON THE "PASS THROUGH" INCREASE OR DECREASE OF RAW MATERIALS AND/OR LABOR, WHICH MAKE UP ALL OR A SUBSTANTIAL PART OF A PRODUCT. ADJUSTMENTS ARE TO BE BASED UPON AN ACTUAL DOLLAR FIGURE, NOT A PERCENTAGE. ALL PRICE ADJUSTMENT REQUESTS MUST BE SUBSTANTIATED IN A MANNER ACCEPTABLE TO THE DIRECTOR PURCHASING, E.G. GOVERNMENTAL BENCH MARKS, GENERAL MARKET INCREASE, PUBLISHED PRICE LISTS. SUCH REQUESTS FOR AND INCREASE SHOULD BE RECEIVED IN WRITING BY THE DIRECTOR OF PURCHASING AT LEAST 30 DAYS IN ADVANCE OF THE EFFECTIVE DATE OF THE INCREASE. ANY TIME THE VENDOR REQUESTS A PRICE ADJUSTMENT, THE PURCHASING DIVISION MAY EITHER ACCEPT THE PRICE ADJUSTMENT AND AMEND THE CONTRACT ACCORDINGLY OR REJECT THE ADJUSTMENT IN ITS ENTIRETY AND CANCEL THE CONTRACT.</p>					
	EXHIBIT 10					
	REQUISITION NO.: 709EC009...					
	ADDENDUM ACKNOWLEDGEMENT					

SEE REVERSE SIDE FOR TERMS AND CONDITIONS

SIGNATURE <i>Michael W. Allen</i>	TELEPHONE (724) 437-1578	DATE 12/12/08
TITLE V. PRESIDENT	FEN 25-1389795	ADDRESS CHANGES TO BE NOTED ABOVE

WHEN RESPONDING TO RFQ, INSERT NAME AND ADDRESS IN SPACE ABOVE LABELED 'VENDOR'

Jan. 7, 2009 8:33AM



State of West Virginia
Department of Administration
Purchasing Division
2019 Washington Street East
Post Office Box 50130
Charleston, WV 25305-0130

Request for Quotation

No. 1191 P. 7

RFQ NUMBER
709EC009

PAGE
5

ADDRESS CORRESPONDENCE TO ATTENTION OF
**MICHAEL AUSTIN
304-558-2402**

RFQ NO. 709EC009

***709015804 724-437-1578
UNIONTOWN INDUSTRIAL EQUIP CO
2266 UNIVERSITY DR
LEMONT FURNACE PA 15478**

RFQ NO. 709EC009

**DIVISION OF HIGHWAYS
EQUIPMENT DIVISION
ROUTE 33
BRUSHY FORK ROAD
BUCKHANNON, WV
26201
304-472-1750**

DATE PRINTED	TERMS OF SALE	SHIP VIA	FOB	FREIGHT TERMS
12/02/2008				

BID OPENING DATE: **01/07/2009** BID OPENING TIME **01:30PM**

LINE	QUANTITY	UOP	CAT NO	ITEM NUMBER	UNIT PRICE	AMOUNT
------	----------	-----	--------	-------------	------------	--------

I HEREBY ACKNOWLEDGE RECEIPT OF THE FOLLOWING CHECKED ADDENDUM(S) AND HAVE MADE THE NECESSARY REVISIONS TO MY PROPOSAL, PLANS AND/OR SPECIFICATION, ETC.

ADDENDUM NO.'S:

- NO. 1
- NO. 2
- NO. 3
- NO. 4
- NO. 5

I UNDERSTAND THAT FAILURE TO CONFIRM THE RECEIPT OF THE ADDENDUM(S) MAY BE CAUSE FOR REJECTION OF BIDS.

VENDOR MUST CLEARLY UNDERSTAND THAT ANY VERBAL REPRESENTATION MADE OR ASSUMED TO BE MADE DURING ANY ORAL DISCUSSION HELD BETWEEN VENDOR'S REPRESENTATIVES AND ANY STATE PERSONNEL IS NOT BINDING. ONLY THE INFORMATION ISSUED IN WRITING AND ADDED TO THE SPECIFICATIONS BY AN OFFICIAL ADDENDUM IS BINDING.

Michael W. Glass
SIGNATURE

Uniontown Industrial Equip. CO. Inc.
COMPANY

December 12, 2008
DATE

SEE REVERSE SIDE FOR TERMS AND CONDITIONS

SIGNATURE <i>Michael W. Glass</i>	TELEPHONE (724) 437-1578	DATE 12/12/08
TITLE V. PRESIDENT	FAX 25-1389795	ADDRESS CHANGES TO BE NOTED ABOVE

WHEN RESPONDING TO RFQ, INSERT NAME AND ADDRESS IN SPACE ABOVE LABELED 'VENDOR'

Jan. 7. 2009 8:33AM

No. 1191 P. 9



State of West Virginia
Department of Administration
Purchasing Division
2019 Washington Street East
Post Office Box 50130
Charleston, WV 25306-0130

Request for Quotation

RFQ NUMBER
709EC009

PAGE
7

ADDRESS CORRESPONDENCE TO ATTENTION OF
**MICHAEL AUSTIN
304-558-2402**

VENDOR

*709015804 724-437-1578
UNIONTOWN INDUSTRIAL EQUIP CO
2266 UNIVERSITY DR
LEMONT FURNACE PA 15478

SHIP TO

DIVISION OF HIGHWAYS
EQUIPMENT DIVISION
ROUTE 33
BRUSHY FORK ROAD
BUCKHANNON, WV
26201 304-472-1750

DATE PRINTED	TERMS OF SALE	SHIP VIA	FOB	FREIGHT TERMS
12/02/2008				

BID OPENING DATE: **01/07/2009** BID OPENING TIME **01:30PM**

LINE	QUANTITY	UOP	CAT. NO.	ITEM NUMBER	UNIT PRICE	AMOUNT
----- MICHAEL W. CLOWER -----						
***** THIS IS THE END OF RFQ 709EC009 ***** TOTAL:						<u>\$33,300.00</u>

SIGNATURE: *Michael W. Clower* SEE REVERSE SIDE FOR TERMS AND CONDITIONS
 TITLE: **V. PRESIDENT** TELEPHONE: **(724) 437-1578** DATE: **12/12/08**
 FEIN: **25-1389795** ADDRESS CHANGES TO BE NOTED ABOVE

WHEN RESPONDING TO RFQ, INSERT NAME AND ADDRESS IN SPACE ABOVE LABELED 'VENDOR'

WEST VIRGINIA DEPARTMENT OF TRANSPORTATION
DIVISION OF HIGHWAYS
EQUIPMENT DIVISION

PROCUREMENT SPECIFICATIONS
NO. 043-1-D

SELF PROPELLED POWER BROOM

1.0 PURPOSE

It is the purpose of these specifications to describe a Self Propelled Power Broom (hereinafter referred to as a "broom" or a "unit") to be purchased for use by the West Virginia Division of Highways (DOH) on an Open End Contract basis.

2.0 BIDDING PROCEDURES

The current purchasing procedures regarding bidding as established by the Department of Administration, Purchasing Division, shall apply. Failure to submit the "Request for Quotation" forms, complete in its entirety and according to directions indicated, may subject the bidder to disqualification. Each bid submitted shall also be accompanied by a Bidder's Evaluation Report completed in detail. Addendums in order, along with exception sheets, should be with Bidder's Evaluation Report. FAILURE TO SUBMIT THE BIDDER'S EVALUATION REPORT, COMPLETE IN ITS ENTIRETY, MAY RESULT IN AUTOMATIC DISQUALIFICATION.

3.0 SPECIFICATIONS

The specifications named herein, mandatory and non-mandatory, establish the acceptable level of quality only and are not intended to reflect a preference or favor any particular brand or vendor.

3.1 EXCEPTIONS TO NON-MANDATORY SPECIFICATIONS

Exception to a non-mandatory unit specification may be made by the bidder, providing the exception is not available from the manufacturer. **Any such exception must be noted on the bidder's evaluation report and should be accompanied by supporting documentation/literature from the manufacturer. Any exception must be indicated on a separate attachment to the bidder's evaluation report and labeled as "Exception to Specifications".** The state reserves the right to determine whether the stated exception does or does not reduce the quality and performance of the unit. Failure to provide information for any exceptions may be grounds for rejection of the bid. The state reserves the right to waive minor irregularities in bids or specifications in accordance with §148-1-4(f) of the WV Legislative Rules and Regulations.

3.2 MANDATORY SPECIFICATIONS

All specifications preceded by "shall, will, and/or must" or are stated as a "minimum and/or maximum" are mandatory as stated in Purchasing Divisions Policies and Procedures. Any bid failing to meet any mandatory item shall be immediately disqualified. Failure to respond in the appropriate evaluation section may also be grounds for immediate disqualification at the discretion of the State.

A mandatory pre-bid conference is scheduled for this equipment purchase as stated in the RFQ. Vendors having products with variations or exceptions in specified mandatory items are expected to address any such variations or exceptions during the pre-bid conference. **The State shall review and consider any such variation or exception, and may at its sole discretion, issue an addendum to change mandatory specifications deemed to be in the State's best interest. Bids from any vendor failing to attend the mandatory pre-bid shall be disqualified. Bids containing any variation or exception to a mandatory specification that was not addressed during the pre-bid conference and accepted by the issuance of an Addendum shall be disqualified.**

4.0 REPRESENTATIVE UNIT FOR TEST

The successful vendor must (if specified) provide DOH one (1) completed representative unit to be observed and evaluated on each order to insure compliance with specification. If requested, the time period for testing and evaluation shall be seven (7) working days following receipt of the unit. DOH will incur no obligation for deterioration of surfaces, finishes, seals, and mechanical or electrical parts on the unit resulting from operation and testing within the limits of these specifications; nor will DOH incur obligation for damage to the unit resulting from failure to meet specifications when due care and attention is given by DOH and testing is done within the limits of these specifications. Failure of the pilot unit to satisfactorily meet specifications as bid shall be cause for cancellation of the purchase order, and return of the delivered unit along with all associated equipment to the vendor at the vendor's expense.

4.1 CONDITION OF UNIT(S) UPON DELIVERY

All units must arrive at the prescribed delivery point having been completely preserviced with oil, lubricants, and coolant. All prescribed precautions pertaining to first operations and break-in of the unit are to be posted conspicuously on the unit for ready observance by the operator.

4.2 DELIVERY

Delivery point of the completely assembled representative unit will be the DOH, Equipment Division, Route 33 at Brushy Fork Road, Buckhannon, West Virginia (26201).

The vendor is responsible for guaranteeing delivery of the completed units within the time specified and agreed to by the State. Delivery is preferred within 120 days after receipt of purchase agreement. The vendor is responsible for establishing and coordinating delivery terms with allied manufacturers or suppliers. **Delivery terms shall be stated in the bid and the State reserves the right to accept or negotiate such terms. Failure to reach an agreement may result in rejection of the bid. The successful**

bidder shall provide their manufacturer's confirmation of the order to the WVDOH contact person within seven (7) working days after receiving the approved purchase order.

A completed pilot model for inspection must be provided within 90 calendar days after receipt of the purchase agreement by the successful vendor.

Delivery is an integral part of this specification and failure to comply will be cause to initiate a D.O.T. Administrative Form WV-82, Vendor Performance Form. The WV-82 Form will provide a means of officially notifying the Purchasing Division and the vendor of unsatisfactory performance; such as late deliveries, poor service, inadequate parts supplies, etc.

The decision to initiate subject Form will be at the sole discretion of the D.O.H. Commissioner's established Equipment Review Board.

Issuance of the WV-82 Vendor Complaint Form on unsatisfactory delivery against any vendor will be cause to refuse to consider similar items from those vendors on future Request For Quotations.

(NOTE: Delivery time could be altered due to labor strikes, severe inclement weather conditions, etc.)

5.0 AWARD CRITERIA

- 5.1 DOH will recommend the award in accordance with the RFQ evaluation criteria described in the requisition. **The award shall be made to the lowest unit cost vendor that meets or exceeds the specifications.**

Prices for the units shall be in quantities of 1-10, and 11 and over. However, for evaluation purposes, we will use quantities 1-10. DOH reserves the right to place multiple orders in any quantity.

6.0 SPECIFICATIONS AND GUIDELINES - GENERAL

6.1 IDENTIFICATION OF THE UNIT BEING PROPOSED

The bidder must identify the unit by manufacturer, model, series, and year of manufacture, in the bid to enable identification by DOH in the manufacturer's specifications of the proposed unit. The bidder will submit complete descriptive literature of the proposed unit, to establish that the bid is the manufacturer's most current model, including latest engineering improvements, which have been, or will imminently be, regularly advertised and sold on the open market. The unit specified herein and offered to be manufactured after January 1, 2008 and be clearly identified and marked with date of manufacture.

6.2 OPERATING AND SERVICE MANUALS AND PARTS LISTS

An operator's manual must be included with each unit upon delivery. A "line sheet" (if applicable) and Equipment Preventative Maintenance Questionnaire (as shown in X6.2 of the Bidder's Evaluation Report) must be with pilot unit upon delivery. In addition, there must be 12 service, shop, or maintenance manuals; ten

(10) to be distributed to the Districts and two (2) for the Equipment Division. Also, there must be 14 parts manuals; ten (10) to be distributed to the Districts and four (4) for Equipment Division use. CD ROM is preferred in lieu of parts or service manuals.

* **NOTE: MANUALS SHALL BE DELIVERED UPON COMPLETION OF DELIVERY OF TOTAL UNITS. FAILURE TO DO SO WILL DELAY PAYMENT.**

6.3 TRAINING:

Manufacturers and/or dealers will be required to stage a thorough seminar on the subjects of Preventative Maintenance, Operator and Mechanic Training. In order to keep the operators and mechanics updated, the successful vendor shall conduct training with each purchase order against this open end contract. Training is preferred within 2 working days after delivery of the pilot unit on the individual purchase order.

Manufacturers and/or dealers shall be required to furnish the Training Academy with one (1) Operator's Manual to be shipped direct to WVDOH Training Academy, Post Office Box 610, Buckhannon, West Virginia 26201 prior to delivery of the pilot.

The seminar to be held at the W. Va. Division of Highways, Equipment Division, Buckhannon, West Virginia.

6.4 PREVENTIVE MAINTENANCE AND OPERATOR PROCEDURES:

Manufacturers and/or dealers will be required to submit to the Equipment Division, in addition to the operating and service manuals, booklets and pamphlets explaining the Preventive Maintenance and Operator Procedures to be used by the operators of this equipment, and must include such things as daily prestart inspection procedure, service schedule, and routine maintenance required, safety precautions, etc.

The successful vendor shall furnish all training aids; i.e., videos, projectors, etc. required in conducting the training.

6.5 WARRANTY AND SERVICE POLICY

The Manufacturers warranty or service policy is to apply to the unit. Such warranty or service policy is to be recognized at any authorized unit dealer, representing manufacturer of proposed unit throughout the State of West Virginia. The applicable warranty or service policy will not be contingent upon obtaining routine service, lubrication, and servicing of the unit from factory authorized agencies. It will be the responsibility of the bidder to have available labor to repair or replace any defective replacement parts, components and materials, and to have available those replacement parts, components, and/or materials found to be defective during the terms of the warranty period. The bidder should state the labor rates, locations where parts will be stocked, availability of parts, and discounts offered for parts, when terms of the warranty offer a pro-rated cost for parts and labor. In addition, the successful bidder should offer field work to repair or replace defective parts, components, and materials found to be defective during the terms of the warranty and should provide mechanic's travel rates,

mileage charges, field mechanic rates, and any surcharge for miscellaneous items, if applicable, for field work during the warranty period. Submit to Division of Highways any technical or engineering improvements during the term of the warranty. **The unit must be accompanied upon delivery by the unit's manufacturer's executed warranty or service policy.**

A mandatory minimum two (2) year bumper to bumper basic parts and labor warranty excluding abuse and normal wear items is required for this unit.

THE "WARRANTY AND SERVICE POLICY QUESTIONNAIRE" ATTACHED IN THE BIDDER'S EVALUATION REPORT MUST BE COMPLETED IN ITS ENTIRETY BY THE SUCCESSFUL BIDDER OR MANUFACTURER PRIOR TO DELIVERY OF THE PILOT MODEL. (SEE SECTION X6.5 OF BIDDER'S EVALUATION REPORT).

6.6 EVALUATION COMMITTEE REQUIREMENTS

Detailed component specifications, product literature, component models, required for specification compliance determination by the Evaluation Committee should be provided with each bid. Any information supplied that is contrary to/or conflicting with the specifications and/or attached Bidders Evaluation Report may be sufficient cause for rejection of bid.

6.7 UNSPECIFIED ACCESSORIES & FEATURES

All parts, equipment, accessories, material, design and performance characteristics not specified herein, but which are necessary to provide a complete unit, must be furnished with each unit and required to conform to strength, quality of material, and quality of workmanship to those which are advertised and provided to the market in general by the unit industry.

All parts and accessories advertised and regularly supplied as standard shall be included, except those which would represent duplication of these specified, and except those which, by specification, are not to be furnished. All standard safety features, required by Federal and State Law, shall be included.

7.0 SPECIFICATIONS OF THE QUOTED UNIT ARE AS FOLLOWS:

It is the intent to describe a self-propelled road sweeper Terramite TSS48 or equal in sufficient detail. All parts not specifically mentioned which are necessary to provide a complete sweeper shall be included.

7.1 Engine:

7.1.1 Engine to be rear mounted for better visibility.

13

7.1.2 Engine shall be diesel type 33 horsepower minimum.

7.1.3 Engine air filtration system shall be Manufacturer's heaviest duty system offered.

7.1.4 Unit to have a Manufacturers heaviest duty 12 volt electrical system.

7.1.5 Engine must be completely covered with a hinged solid metal cover and be lockable.

7.2 Transmission:

7.2.1 Transmission to be fully hydrostatic with speeds infinitely variable from 0 to approximately 7 MPH when sweeping.

7.2.2 Foot control to be provided for forward and reverse, spring loaded to return to neutral position.

7.2.3 Transmission to have two speeds with a neutral position for towing or rear hub locked.

7.3 Steering:

7.3.1 Unit to have power steering

7.4 Brakes:

7.4.1 The braking system shall include an operators pedal (service brake) for better operator control and safety

7.4.2 The braking system shall also include a parking brake for additional safety

7.5 Towing:

7.5.1 Machine is to be towed with no disassembly of any part.

7.6 Brush:

7.6.1 Brush to have a heavy duty shock absorber for balance to take bounce out while sweeping.

7.6.2 Brush to be powered by hydraulic motor, independent of travel speed with direct drive motor located inside brush core.

7.6.3 Unit to be capable of sweeping angles from 40 degrees left to 40 degrees right.

7.6.4 Brush control to be conveniently located and to include stop, rotation, raise, lower, float and lock in any desired position.

- 7.6.5 Brush to be a minimum of 8 feet in length and approximately 24 inches diameter with poly/steel sections.**
- 7.6.6. A cover to be provided approximately 140 degrees over brush with a rubber apron for rock protection.
- 7.6.7 Brush to be mid-mounted on unit under cab.
- 7.6.8 Brush to have a lock position for towing.
- 7.6.9 A governing device to be provided in hydraulic system to control broom speed independently of carriage speed.
- 7.7. Hydraulic System:
- 7.7.1 Unit shall be provided with hydraulic oil cooler.**
- 7.7.2 System to have sufficient oil capacity to operate at maximum efficiency within Manufacturer's recommended operating temperature.
- 7.7.3 A minimum of two (2) 10 micron filters to be provided at suction and return sections of system.**
- 7.7.4 Shut-off valves to be provided for changing of filters if needed.
- 7.7.5 A sight glass to be incorporated in system for visual inspection of hydraulic oil.
- 7.8 Cab and Accessories:
- 7.8.1 Cab to be ROPS enclosed with sound deadening feature.
- 7.8.2 Cab to have lockable doors right and left side (keyed alike).
- 7.8.3 Tinted safety glass to be provided.
- 7.8.4 Front and rear wipers and washers to be provided.
- 7.8.5 Deluxe suspension seat with arm rest to be provided.
- 7.8.6 Unit to have right, left, and inside rear view mirrors.
- 7.8.7 Cab to be equipped with pressurized air conditioner and heater with filter system.
- 7.8.8 A mini light bar (Whelen PT#C200A000 or equal) to be provided and mounted on unit cab.
- 7.8.9 Unit to have work lights front and rear and with stop/tail and turn signals.
- 7.8.10 Fenders to be provided over all four wheels.

- 15 7.9 Gauges to be provided:
- 7.9.1 Voltmeter/Ammeter
 - 7.9.2 Engine oil pressure
 - 7.9.3 Engine water temperature
 - 7.9.4 Hydraulic oil temperature
 - 7.9.5 Hourmeter
- 7.10 Tilt and telescoping steering wheel to be provided.
- 7.11 Unit to be equipped with Manufacturers vandalism protection.
- 7.12 Same wheel and tire to fit all four wheels.
- 7.13 Sprinkler System:
- 7.13.1 Sweeper to have approximately 100 gallon water reservoir.
 - 7.13.2 Galvanized or rust proof piping to be provided with a **minimum of eight (8) nozzles on spray bar.**
 - 7.13.3 An electric pump to be incorporated in system.
 - 7.13.4 A 100 mesh strainer to be provided in water system.
 - 7.13.5 Tank to be polyethylene with vented filler cap.
 - 7.13.6 A back-flow valve to be provided to prevent drainage when not in use.
 - 7.13.7 Drain plug to be provided on tank.
- 7.14 **Unit shall be delivered to WV DOH with all Manufacturers recommended safety related decals and safety features intact.**
- 7.15 Paint:
- 7.15.1 The entire unit to be painted manufacturers standard color(s)
 - 7.15.2 **The entire unit shall be thoroughly cleaned and free from grease, rust, and scale.**
- 7.16 **Vendor must certify that unit offered will meet or exceed the "Occupational Safety and Health Act of 1970" and subsequent amendments.**
- 7.17 Advertising: No visible decals or name plates or painted on names other than Manufacturer or model number or trademark should appear on the exterior surface of the unit. Such logos created through the stamping or casting process of Manufacture are accepted.

WEST VIRGINIA DEPARTMENT OF TRANSPORTATION
DIVISION OF HIGHWAYS
EQUIPMENT DIVISION

BIDDER'S EVALUATION REPORT

PROCUREMENT SPECIFICATIONS FOR OPEN END CONTRACT
NO. 043-1-D

SELF PROPELLED POWER BROOM

NOTE TO BIDDER: Procurement Specification No. 043-1-D, Paragraph 2.0 recommends the completion and submittal of this Report with your bid. Purpose of this Report is to enable the West Virginia Division of Highways Evaluation Committee to make full and fair evaluation of the bid. Addendums in order, along with a summary of exception as a separate attachment, should be with Bidder's Evaluation Report.
FAILURE TO SUBMIT THIS REPORT, COMPLETE IN ITS ENTIRETY, MAY SUBJECT THE BIDDER TO DISQUALIFICATION.

Reference Requisition No.: 709EC009

Bidder's Name: Uniontown Industrial Equipment Co. Inc.

Address: 2266 University Drive Lemont FURNACE PA 15456

Telephone Number: (724) 437-1578

Years Bidder has been registered to do business with the State of West Virginia: 13 YRS.

Years Company has been an authorized dealer for proposed unit: 7 YRS.

X3.2 Have you complied with all mandatory specifications? YES NO

X4.2 DELIVERY:

X4.2.1 Delivery date of completed representative unit: 60 Calendar Days After
Receipt of Purchase Agreement

X4.2.2 Delivery date of balance of completed units: 105 Calendar Days After Receipt of
Purchase Agreement

The "Bidder's Evaluation Report" is available for download on Purchasing's Web site at
www.state.wv.us/admin/purchase

X5.0 AWARD CRITERIA;

X5.1 Prices for units:

1-10 \$33,300.00 per unit

11 and over \$33,300.00 per unit

X6.0 SPECIFICATIONS - GENERAL

X6.1 Manufacturer, model, series, and date of manufacture of proposed unit:

LAYMOR 8HC (2009)

Is descriptive literature, fully describing proposed unit attached to your bid? YES NO

If not, why? _____

X6.2 Will the required number of service manuals, and complete parts list be delivered to the Equipment Division at Buckhannon upon completion of delivery of total units?

YES NO

Will the required Equipment Preventive Maintenance Form (Section X6.2 of Bidders Evaluation Report) be provided upon inspection of the pilot unit?

YES NO

X6.2
2-10-00

EQUIPMENT PREVENTATIVE MAINTENANCE QUESTIONNAIRE

THIS FORM MUST BE COMPLETED IN ITS ENTIRETY BY SUCCESSFUL BIDDER OR MANUFACTURER'S TECHNICAL REPRESENTATIVE PRIOR TO DELIVERY OF PILOT MODEL TO THE WVDOH.

DESCRIPTION: _____ MAKE: _____

MODEL: _____ YEAR: _____ PURCHASE AMOUNT: _____

ENGINE: MAKE: _____ MODEL: _____ FUEL TYPE: _____

HORSEPOWER: _____ CYLINDER: _____ ENGINE SERIAL: _____

COOLING SYSTEM CAPACITY: _____

BELTS: DESCRIPTION: _____ PART NUMBERS: _____

GVW: _____ AXLE CAPACITY: FRONT: _____ REAR: _____

TIRES: FRONT MAKE & SIZE: _____

REAR MAKE & SIZE: _____

DIMENSIONS OF UNIT: LENGTH: _____ WIDTH: _____ LENGTH: _____

VENDOR CONTACT PERSON: _____ PHONE: _____

PARTS:

BATTERY MAKE: _____ MODEL: _____ CCA: _____

TOP OR SIDE POST: _____ DIMENSIONS: LENGTH _____ WIDTH _____ HEIGHT _____

SPARK PLUGS OR FUEL INJECTORS MAKE: _____ PART # _____

FUEL PUMP OR INJECTION PUMP MAKE: _____ MODEL: _____

ALTERNATOR MAKE: _____ PART #: _____

STARTER MAKE: _____ PART #: _____

TURBO CHARGER MAKE: _____ PART #: _____

TRANS. MAKE: _____ MODEL: _____ AUTO/MANUAL: _____

HYDRAULIC PUMP MAKE: _____ MODEL: _____

FILTERS MAKE PART NO. LUBRICANT MANUFACTURER TYPE

OIL _____ ENGINE _____

AIR INNER _____ TRANSMISSION _____

AIR OUTER _____ POWER STEERING _____

FUEL PRIMARY _____ HYDRAULIC _____

FUEL SECONDARY _____ DIFFERENTIALS _____

COOLANT _____ BRAKE FLUID _____

HYDRAULIC _____ COOLANT _____

OTHER _____ OTHER _____

X6.3 TRAINING:

Will training seminar be conducted on Preventive Maintenance, Operator and Mechanic Training YES NO

Will you conduct training with each purchase order against this open end contract? YES NO

Will training be conducted within 2 working days from the delivery of the pilot unit on the individual purchase order? YES NO

If NO, explain time frame 2 WEEKS

Will an Operator's Manual be furnished directly to Training Academy prior to the delivery of the pilot? YES NO

X6.4 If you are the successful vendor, will you furnish all training aids, i.e., videos, projectors, required in conducting the training? YES NO

X6.4.1 Will all manuals, booklets, etc. explaining preventive maintenance, operator procedures, and service schedule be delivered with each unit? YES NO
If NO, explain _____

X6.5 WARRANTY AND SERVICE POLICY

Will the warranty and service you provide comply with all areas as stated in Section 6.5 of specifications YES NO

Is warranty literature attached? YES NO

Is a minimum two (2) year bumper to bumper basic parts and labor warranty excluding abuse and normal wear items included? YES NO

Describe: 2 YEAR OR 1,000 HOURS, WHICHEVER OCCURS FIRST

X6.5 WARRANTY AND SERVICE POLICY QUESTIONNAIRE

THIS FORM MUST BE COMPLETED IN ITS ENTIRETY AND SUBMITTED WITH YOUR BID.

(If additional lines are needed, make copies of form.)

1. Define the terms of the standard warranty. If not offered, so state. (Attach copy)

2 YEAR BUMPER TO BUMPER

2. Define warranty service to be performed at DOH facilities and warranty service to be performed at manufacturer's representative facility. List name and location of manufacturer's representative.
WHEN WARRANTY SERVICE IS PREFORMED AT DOH FACILITIES DOH IS RESPONSIBLE FOR TRAVEL & MILEAGE TO AND FROM THEIR FACILITY. WHEN WARRANTY SERVICE IS PREFORMED AT UIEC DOH IS RESPONSIBLE FOR ROUND TRIP TRANSPORTATION.

3. List locations for parts inventories that are within the State of West Virginia. Also, list availability levels, if known.

LEMONT FURNACE, PA

4. During the term of warranty, list the guarantee discount to manufacturer's published list price for parts that bidder will sell the parts to owner.

A. Terms: Net 30	Manufacturer's published list price less: <u>0</u> % discount
B. Terms: Net 60	Manufacturer's published list price less: <u>0</u> % discount
C. Terms: Net 90	Manufacturer's published list price less: <u>0</u> % discount

5. During the term of warranty, will all manufacturers or engineering improvements be submitted to Division of Highways? X YES NO

6. During the term of warranty, list the guaranteed rates charged for repair to the unit.

A. Shop Rate \$ 65.00 per mechanic hour

B. Travel Time Charge \$ 65.00 per mechanic hour
(Specify if one-way) NA; port to port NA

C. Mileage Charge \$ 65.00 per vehicle mile
(Specify if one-way) NA; port to port NA

D. Field Mechanic Rate \$ 65.00 per mechanic hour

E. Specify period of time that prices are in effect: 1 YEAR (12/31/09)

F. Surcharge for miscellaneous items: NA %

X6.6 EVALUATION COMMITTEE REQUIREMENTS

Is all component specifications, product literature, component models provided for Evaluation Committee bid determination? X YES NO

X6.7 Will all parts, equipment, accessories, material, design and performance characteristics not specified herein, but which are necessary to provide a complete unit, be furnished with the unit and conform in strength, quality of material, and quality of workmanship to those which are advertised and provided to the market in general by the unit industry?
 X YES NO

X6.7.1 Are all parts and accessories adequate and regularly supplied as standard to be included except those which may be duplications of specifications herein, and except these by specification are not to be furnished?
 X YES NO

X6.7.2 Are all standard safety features that are required by Federal and State statutes of law included?
 X YES NO

X7.0 SPECIFICATIONS OF THE QUOTED UNIT:

The bidder should complete the following schedule in order for the Division to compare the actual bid unit to the specifications. Should the bidder except a requirement, then such exception may be only on the basis that such feature is not offered by the manufacturer. The Division will have the sole discretion as to whether the bidder's substitution meets the requirements of the specification.

Manufacturer: LAYMOR 2009 Model: 8HC

It is the intent to describe a self-propelled road sweeper in sufficient detail. Are all parts not specifically mentioned which are necessary to provide a complete sweeper included. X YES NO

X7.1 Engine:

X7.1.1 Is engine rear mounted? X YES NO

X7.1.2 Is engine diesel type? X YES NO
Specify engine horsepower KUBOTA V1505 DIESEL

X7.1.3 Is engine air filtration system Manufacturer's heaviest duty system offered? X YES NO

X7.1.4 Will unit have manufacturers heaviest duty 12 volt electrical system? X YES NO

X7.1.5 Is engine completely covered with hinged solid metal cover and lockable? X YES NO

X7.2 Transmission:

X7.2.1 Will transmission be fully hydrostatic? YES NO
 Speeds infinitely variable from 0 to 7 MPH

X7.2.2 Will foot control provided be forward and reverse, spring loaded to return to neutral position? YES NO

X7.2.3 Is transmission 2 speed with a neutral position for towing or rear hub locked? YES NO
 If not specify _____

X7.3 Steering:

X7.3.1 Will unit be power steering YES NO

X7.4 Brakes:

X7.4.1 Does braking system include an operators pedal (service brake) for better operator control and safety YES NO

X7.4.2 Does braking system include a parking brake for additional safety YES NO

X7.5 Towing:

X7.5.1 Can machine be towed without disassembly of any parts? YES NO

X7.6 Brush:

X7.6.1 Does brush have heavy duty shock absorber for balance to take bounce out while sweeping? YES NO

X7.6.2 Will brush be powered by hydraulic motor independent of travel speed with direct drive motor located inside brush core? YES NO

X7.6.3 Is unit capable of sweeping angles?
 Specify 45 degrees left 45 degrees right YES NO

X7.6.4 Will brush control be conveniently located to include stop, rotation, raise, lower, float/lock in any desired position? YES NO

X7.6.5 Does brush have poly/steel sections? YES NO
 Length: 8 ' Diameter: 24" inches

X7.6.6 Will a cover over brush be provided w/a rubber apron for rock protection? YES NO
280 degrees brush coverage

X7.6.7 Will brush be mid-mounted on unit under cab? YES NO

- X7.6.8 Does brush have a lock position for towing? YES NO
- X7.6.9 Will a governing device be provided in hydraulic system to control broom speed independently of carriage speed? YES NO
- X7.7. Hydraulic System:
- X7.7.1 Does unit have a hydraulic oil cooler? YES NO
- X7.7.2 Does hydraulic system have sufficient oil capacity to operate at maximum efficiency within manufacturer's recommended operating temperature? YES NO
- X7.7.3 Will minimum of two (2) 10 micron filters be provided at suction and return sections of system? YES NO
- X7.7.4 Will shut-off valves be provided for changing of filters if needed? YES NO
- X7.7.5 Is a sight glass incorporated in system for visual inspection of hydraulic oil? YES NO
- X7.8 Cab and Accessories:
- X7.8.1 Will cab be ROPS enclosed with sound deadening feature? YES NO
- X7.8.2 Does cab have right and left side lockable doors (keyed alike)? YES NO
- X7.8.3 Will tinted safety glass be provided? YES NO
- X7.8.4 Will front and rear wipers and washers be provided? YES NO
- X7.8.5 Does unit have a deluxe suspension seat with armrest? YES NO
- X7.8.6 Does unit have right, left and inside rear view mirrors? YES NO
- X7.8.7 Will cab be equipped with pressurized AC and heater with filter system? YES NO
- X7.8.8 Does unit have a mini light bar (Whelen PT#C200A000 or equal) mounted on cab? YES NO
- X7.8.9 Will unit have work lights front and rear with stop/tail and turn signals? YES NO
- X7.8.10 Will fenders be provided over all four (4) wheels? YES NO
- X7.9 Gauges to be provided:
- X7.9.1 Will unit have Voltmeter/Ammeter? YES NO
- X7.9.2 Will unit have engine oil pressure gauge? YES NO

- X7.9.3 Will unit have engine water temperature gauge? YES NO
- X7.9.4 Will unit have Hydraulic Oil temperature gauge? YES NO
- X7.9.5 Will unit have hourmeter? YES NO
- X7.10 Will unit have tilt and telescoping steering wheel? YES NO
- X7.11 Will unit be equipped with manufacturers vandalism protection? YES NO
- X7.12. Will same wheel and tire fit all four (4) wheels? YES NO
- X7.13 Sprinkler System:
 - X7.13.1 Will sweeper have a water reservoir?
Specify 80 U.S. gallons YES NO
 - X7.13.2 Will galvanized or rust proof piping be provided
Number of nozzles on spray bar: 8 YES NO
 - X7.13.3 Will an electric pump be incorporated in system? YES NO
 - X7.13.4 Will a 100 mesh strainer be provided in water system? YES NO
 - X7.13.5 Will tank be polyethylene with vented filler cap? YES NO
 - X7.13.6 Does unit have a back-flow valve preventing drainage when not in use? YES NO
 - X7.13.7 Will a drain plug be provided on tank? YES NO
- X7.14 Will unit be provided with all manufacturers recommend safety related decals and safety features intact? YES NO
- X7.15 Paint:
 - X7.15.1 Will entire unit be painted manufacturers standard color(s)? YES NO
 - X7.15.2 Will entire unit be thoroughly cleaned/free from grease, rust and scale? YES NO
- X7.16 Will unit meet all OSHA and subsequent amendments requirement? YES NO
- X7.17 Will advertising meet requirements as specified? YES NO

VENDOR PREFERENCE CERTIFICATE

Certification and application* is hereby made for Preference in accordance with *West Virginia Code*, §5A-3-37. (Does not apply to construction contracts). *West Virginia Code*, §5A-3-37, provides an opportunity for qualifying vendors to request (at the time of bid) preference for their residency status. Such preference is an evaluation method only and will be applied only to the cost bid in accordance with the *West Virginia Code*. This certificate for application is to be used to request such preference. The Purchasing Division will make the determination of the Resident Vendor Preference, if applicable.

1. Application is made for 2.5% resident vendor preference for the reason checked:
 Bidder is an individual resident vendor and has resided continuously in West Virginia for four (4) years immediately preceding the date of this certification; or,
 Bidder is a partnership, association or corporation resident vendor and has maintained its headquarters or principal place of business continuously in West Virginia for four (4) years immediately preceding the date of this certification; or 80% of the ownership interest of Bidder is held by another individual, partnership, association or corporation resident vendor who has maintained its headquarters or principal place of business continuously in West Virginia for four (4) years immediately preceding the date of this certification; or,
 Bidder is a nonresident vendor which has an affiliate or subsidiary which employs a minimum of one hundred state residents and which has maintained its headquarters or principal place of business within West Virginia continuously for the four (4) years immediately preceding the date of this certification; or,
2. Application is made for 2.5% resident vendor preference for the reason checked:
 Bidder is a resident vendor who certifies that, during the life of the contract, on average at least 75% of the employees working on the project being bid are residents of West Virginia who have resided in the state continuously for the two years immediately preceding submission of this bid; or,
3. Application is made for 2.5% resident vendor preference for the reason checked:
 Bidder is a nonresident vendor employing a minimum of one hundred state residents or is a nonresident vendor with an affiliate or subsidiary which maintains its headquarters or principal place of business within West Virginia employing a minimum of one hundred state residents who certifies that, during the life of the contract, on average at least 75% of the employees or Bidder's affiliate's or subsidiary's employees are residents of West Virginia who have resided in the state continuously for the two years immediately preceding submission of this bid; or,
4. Application is made for 5% resident vendor preference for the reason checked:
 Bidder meets either the requirement of both subdivisions (1) and (2) or subdivision (1) and (3) as stated above; or,
5. Application is made for 3.5% resident vendor preference who is a veteran for the reason checked:
 Bidder is an individual resident vendor who is a veteran of the United States armed forces, the reserves or the National Guard and has resided in West Virginia continuously for the four years immediately preceding the date on which the bid is submitted; or,
6. Application is made for 3.5% resident vendor preference who is a veteran for the reason checked:
 Bidder is a resident vendor who is a veteran of the United States armed forces, the reserves or the National Guard, if, for purposes of producing or distributing the commodities or completing the project which is the subject of the vendor's bid and continuously over the entire term of the project, on average at least seventy-five percent of the vendor's employees are residents of West Virginia who have resided in the state continuously for the two immediately preceding years.

Bidder understands if the Secretary of Revenue determines that a Bidder receiving preference has failed to continue to meet the requirements for such preference, the Secretary may order the Director of Purchasing to: (a) reject the bid; or (b) assess a penalty against such Bidder in an amount not to exceed 5% of the bid amount and that such penalty will be paid to the contracting agency or deducted from any unpaid balance on the contract or purchase order.

By submission of this certificate, Bidder agrees to disclose any reasonably requested information to the Purchasing Division and authorizes the Department of Revenue to disclose to the Director of Purchasing appropriate information verifying that Bidder has paid the required business taxes, provided that such information does not contain the amounts of taxes paid nor any other information deemed by the Tax Commissioner to be confidential.

Under penalty of law for false swearing (*West Virginia Code*, §61-5-3), Bidder hereby certifies that this certificate is true and accurate in all respects; and that if a contract is issued to Bidder and if anything contained within this certificate changes during the term of the contract, Bidder will notify the Purchasing Division in writing immediately.

Bidder: Uniontown Industrial Equip

Signed: Michael W. Allen

Date: 12/12/08

Title: V. PRESIDENT

*Check any combination of preference consideration(s) indicated above, which you are entitled to receive.

STATE OF WEST VIRGINIA
Purchasing Division

PURCHASING AFFIDAVIT

VENDOR OWING A DEBT TO THE STATE:

West Virginia Code §5A-3-10a provides that: No contract or renewal of any contract may be awarded by the state or any of its political subdivisions to any vendor or prospective vendor when the vendor or prospective vendor or a related party to the vendor or prospective vendor is a debtor and the debt owed is an amount greater than one thousand dollars in the aggregate.

PUBLIC IMPROVEMENT CONTRACTS & DRUG-FREE WORKPLACE ACT:

West Virginia Code §21-1D-5 provides that: Any solicitation for a public improvement construction contract shall require each vendor that submits a bid for the work to submit at the same time an affidavit that the vendor has a written plan for a drug-free workplace policy in compliance with Article 1D, Chapter 21 of the West Virginia Code. A public improvement construction contract may not be awarded to a vendor who does not have a written plan for a drug-free workplace policy in compliance with Article 1D, Chapter 21 of the West Virginia Code and who has not submitted that plan to the appropriate contracting authority in timely fashion. For a vendor who is a subcontractor, compliance with Section 5, Article 1D, Chapter 21 of the West Virginia Code may take place before their work on the public improvement is begun.

ANTITRUST:

In submitting a bid to any agency for the state of West Virginia, the bidder offers and agrees that if the bid is accepted the bidder will convey, sell, assign or transfer to the state of West Virginia all rights, title and interest in and to all causes of action if may now or hereafter acquire under the antitrust laws of the United States and the state of West Virginia for price fixing and/or unreasonable restraints of trade relating to the particular commodities or services purchased or acquired by the state of West Virginia. Such assignment shall be made and become effective at the time the purchasing agency tenders the initial payment to the bidder.

I certify that this bid is made without prior understanding, agreement, or connection with any corporation, firm, limited liability company, partnership or person or entity submitting a bid for the same materials, supplies, equipment or services and is in all respects fair and without collusion or fraud. I further certify that I am authorized to sign the certification on behalf of the bidder or this bid.

LICENSING:

Vendors must be licensed and in good standing in accordance with any and all state and local laws and requirements by any state or local agency of West Virginia, including, but not limited to, the West Virginia Secretary of State's Office, the West Virginia Tax Department, West Virginia Insurance Commission, or any other state agencies or political subdivision. Furthermore, the vendor must provide all necessary releases to obtain information to enable the Director or spending unit to verify that the vendor is licensed and in good standing with the above entities.

CONFIDENTIALITY:

The vendor agrees that he or she will not disclose to anyone, directly or indirectly, any such personally identifiable information or other confidential information gained from the agency, unless the individual who is the subject of the information consents to the disclosure in writing or the disclosure is made pursuant to the agency's policies, procedures and rules. Vendors should visit www.state.wv.us/admin/purchase/privacy for the Notice of Agency Confidentiality Policies.

Under penalty of law for false swearing (West Virginia Code §61-5-3), it is hereby certified that the vendor acknowledges the information in this said affidavit and is in compliance with the requirements as stated.

Vendor's Name: UNiontown Industrial Equipment Co. Inc.

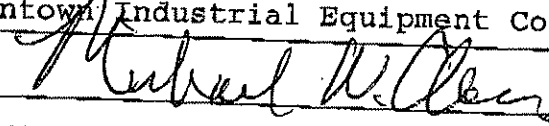
Authorized Signature:  Date: 12/12/08

Unlontown Industrial Equipment Co., Inc.

100 College Drive • Lemont Furnace, PA 15456
Telephone (724) 437-1578 Fax (724) 437-2098

"EXCEPTION TO SPECIFICATIONS"

- X 7.7.4 SHUT OFF VALVES FOR FILTER CHANGE NOT AVAILABLE
- X 7.8.3 NO TINTED GLASS IN CAB
- X 7.8.5 SUSPENSION SEAT (Standard seat does have armrests)
- X 7.8.10 FENDERS ONLY OVER REAR WHEELS
- X 7.10 TILT & TELESCOPING STEERING NOT AVAILABLE
- X 7.3.1 ASSISTED POWER STEERING
- X 7.4.1 OPERATORS PEDAL FOR BRAKE NOT NEEDED





Mobile Products Inc.
 401 Capacity Drive
 Longview, TX 75604
 Phone (903) 759-0610
 FAX (903) 759-3209

Uniontown Industrial Eq.
 2266 University Dr.
 Lemont Furnace, PA 15456
 Attn: Mike Clower
 Phone: 724 437 1578
 Fax: 724 437 2098
 Email: office@uiec.com
 Date: January 1, 2009

Lay-Mor 8HC Sweeper

Qty	Part No.	Description
1	374571	8HC Diesel Self-Propelled Rotary Broom Sweeper w/ Kubota V1505 engine (37 HP), Tow System, R.O.P.S., and Reverse Alarm
1	376947	Variable Broom Speed
1	9103142	Dual Mirrors
1	spl	Whelen Mini Light Bar (PT# C200A000)
1	379024	Front & Rear Halogen Lights
1	9103147	Emergency Warning & Turn Signal Lights
1	374983	8' Broom Head (1/2 Poly, 1/2 Wire)
1	374728	2" Ball Hitch
1	374645	8' Head, 80 Gallon Water Control System
1	374967	Automatic Engine Protection Shut Down System
1	386193	Hub Engaged Warning System (horn, light, decal)
1	spl	2 Year Limited Warranty (Parts & Labor)
		Total
1	374720	Vista Cab- Deluxe Package-Includes A/C, Heater, Defroster, Pressurizer, 2 Speed Windshield Wiper/Washer (Front & Rear), Headliner, Floormat, 2 Doors (note: No substitutions or deletions on cab option)
		Grand Total

Freight

Exceptions

- Brush Lock Position for Towing
- Shut off valves for filter change not available
- No Tinted glass in cab
- Suspension Seat (Standard seat does have armrests)
- Fenders only over rear wheels
- Tilt & Telescoping steering not available
- Assisted Power Steering
- Operators pedal for brake not needed

Warranty: 2 year or 1,000 hours, whichever comes first
 Terms: Net 30 Days
 Freight: FOB Longview, TX



Mobile Products Inc.
 401 Capacity Drive
 Longview, TX 75604
 Phone (903) 759-0610
 FAX (903) 759-3209

Uniontown Industrial Eq.
 2266 University Dr.
 Lemont Furnace, PA 15456
 Attn: Mike Clower
 Phone: 724 437 1578
 Fax: 724 437 2098
 Email: office@ulec.com
 Date: January 1, 2009

Lay-Mor 8HC Sweeper

Qty	Part No.	Description
1	374571	8HC Diesel Self-Propelled Rotary Broom Sweeper w/ Kubota V1505 engine (37 HP), Tow System, R.O.P.S., and Reverse Alarm
1	376947	Variable Broom Speed
1	9103142	Dual Mirrors
1	spl	Whelen Mini Light Bar (PT# C200A000)
1	379024	Front & Rear Halogen Lights
1	9103147	Emergency Warning & Turn Signal Lights
1	374983	8' Broom Head (1/2 Poly, 1/2 Wire)
1	374728	2" Ball Hitch
1	374645	8' Head, 80 Gallon Water Control System
1	374967	Automatic Engine Protection Shut Down System
1	386193	Hub Engaged Warning System (horn, light, decal)
1	spl	2 Year Limited Warranty (Parts & Labor)
		Total
1	374720	Vista Cab- Deluxe Package-Includes A/C, Heater, Defroster, Pressurizer, 2 Speed Windshield Wiper/Washer (Front & Rear), Headliner, Floormat, 2 Doors (note: No substitutions or deletions on cab option)

Grand Total

Freight

Exceptions

- Brush Lock Position for Towing*
- Shut off valves for filter change not available*
- No Tinted glass in cab*
- Suspension Seat (Standard seat does have armrests)*
- Fenders only over rear wheels*
- Tilt & Telescoping steering not available*
- Assisted Power Steering*
- Operators pedal for brake not needed*

Warranty: 2 year or 1,000 hours, whichever comes first
 Terms: Net 30 Days
 Freight: FOB Longview, TX

Uniontown Industrial Equipment Co., Inc.

100 College Drive • Lemont Furnace, PA 15456 "EXCEPTION TO SPECIFICATIONS"

Telephone (724) 437-1578 Fax (724) 437-2098

- X 7.7.4 SHUT OFF VALVES FOR FILTER CHANGE NOT AVAILABLE
- X 7.8.3 NO TINTED GLASS IN CAB
- X 7.8.5 SUSPENSION SEAT (Standard seat does have armrests)
- X 7.8.10 FENDERS ONLY OVER REAR WHEELS
- X 7.10 TILT & TELESCOPING STEERING NOT AVAILABLE
- X 7.3.1 ASSISTED POWER STEERING
- X 7.4.1 OPERATORS PEDAL FOR BRAKE NOT NEEDED

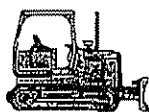

MOBILE PRODUCTS, INC.

Warranty Policy & Procedure Manual

For All Products Manufactured by

MOBILE PRODUCTS, INC.

Rev. Nov.27 , 2000

Mobile Products, Inc.

INTRODUCTION

In an effort to insure the satisfaction of our customers and distributors, MOBILE PRODUCTS, INC. has developed this comprehensive policy and procedures manual. Our goal is to establish policies that will enable consistent, prompt and equitable processing of warranty request.

MOBILE PRODUCTS, INC., warranty policy and procedures manual should enable our distributors to classify whether or not a service repair is really warrantable. The distributor can then deal with the customer more effectively. We at MOBILE PRODUCTS, INC. want to make justified warranty a prompt, consistent and equitable experience for our mutual customers.

It is vital that the warranty registration card be completed and returned to MOBILE PRODUCTS, INC., immediately following delivery of equipment to the customer. Warranty claims will not be processed if warranty registration is not filed within 30 days.

Please consider each claim on its own merits, remembering that this is directly proportionate to your future ability to provide a quality product at a reasonable price.

We recommend that all people who deal with warranty service administration become familiar with the procedures contained in this manual.

"Please make sure that your WARRANTY REGISTRATION CARDS are returned within 30 days."

WARRANTY PROCEDURES

I. DETERMINATION OF WARRANTABLE SERVICE:

There is always the question as to whether a repair or replacement is actually a warrantable adjustment. This section is included to help you make that decision. All warranty claims must be filed within the warranty period and within 30 days of the failure.

Sweepers (All Models) 12 months or 1000 hours whichever comes first

The claim will not be honored if it does not meet these criteria.

II. WARRANTY AND CUSTOMER RELATIONS:

It is very important that the first contact with the customer be conducted properly. Remember, your goal should be to give the best service possible. Blanket statements and empty promises do not help the customer, the distributor, or MOBILE PRODUCTS, INC..

We are not asking that you discourage the customer from expecting warranty adjustments. However, the customer deserves the right to know that warranty adjustment is not automatic, and you cannot insure approval of the claim. It is easier to inform the customer of procedures from the beginning. If this is done, the customer will probably be more reasonable if a claim is denied.

III. DETERMINING WARRANTY RESPONSIBILITY:

Even though the unit has a definite problem, the answers to a few questions must be established before you can determine if it is a warrantable problem.

A. Has the complaint originated during the stated warranty period?

B. Is the malfunction a result of abuse or misuse?

If there is evidence of abuse, tactfully convey your observation to the customer. The time to inform your customer is when you notice the possibility of abuse and not when MOBILE PRODUCTS, INC., denies the claim because of abuse.

C. Has the unit been maintained properly?

D. If the complaint has originated during the warranty period, there is no evidence of abuse or misuse and it seems the unit has proper maintenance, the distributor should proceed to file a warranty claim. This does not, however, insure that the claim will be approved.

E. Is warranty card on file?

IV. WHEN TO CONTACT THE FACTORY FOR A WARRANTY CLAIM:

LAY·MOR®

Model 6HC/8HC

Three Wheel Sweeper

- Broom down pressure easily adjusted to match job
- Translucent water tanks for quick view of water level
- Advanced hitch/towing package
- Certified roll-over protection structure
- New swing up hood for easy engine access
- Available with 6' or 8' brush

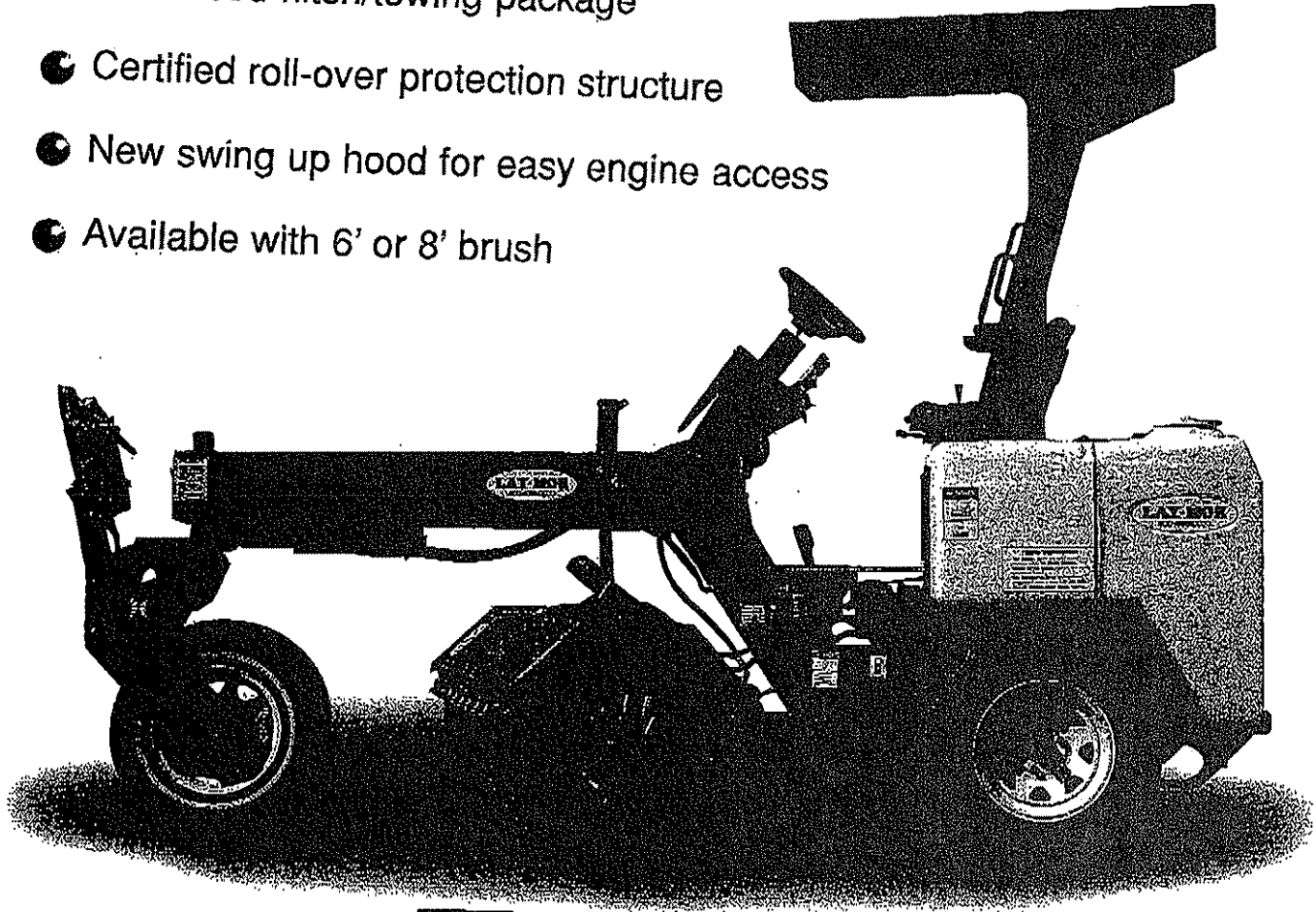

DESIGNED TO INCREASE RENTAL UPTIME

Proven and accepted as #1 leader in the rental sweeping industry, the Lay-Mor Model 6HC/8HC is operator friendly and is easily transported from job to job. There is no need to raise the front wheel off the ground for towing purposes and the tongue can pivot right or left and up and down for faster and easier hook-up. More easily accessible maintenance allows for servicing the unit quicker and simpler than competitive products.

LAY·MOR

Primary Features and Benefits

Hitch/Towing Package

A whole new approach in towing package design. We've eliminated the jack so that hitching up is an easy one-man operation. Our advanced design assures minimum tongue weight and more evenly distributed load due to three-wheels-on-ground towing, even with fully loaded sprinkler system. Hitch mount comes equipped with surge brakes, towing lights and turn signals.

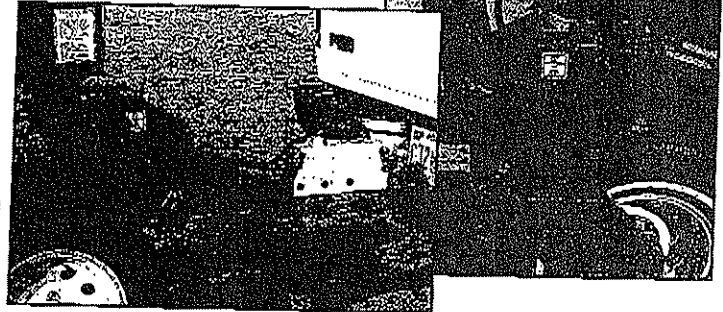

A sturdy protective cover has been added to prevent hub damage. Also, our new front fork pivot bearings have more bearing area for longer life and less wear.

Broom

Lay-Mor's exclusive down pressure control is designed to maintain optimum broom-to-ground contact. This feature also ensures maximum brush life.



A full length debris shield has been added to minimize dust and debris. The standard dust control sprinkler system includes spray nozzles integrated into the broom cover for a cleaner design, more effective water distribution and, by eliminating the need for a spray bar, fewer parts to maintain.

Large skid plates installed on the broom mounting assure longer life in heavy wear applications. We've gone to a single, larger field-proven long life broom drive motor - a design used for years in our four wheel sweepers.

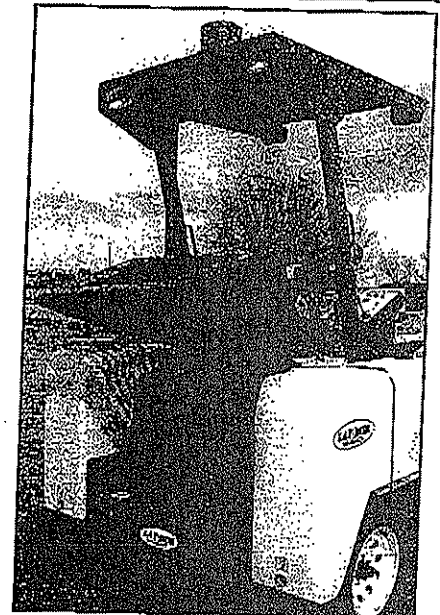

Engine Access

Our new swing-up hood offers quicker engine component service with less hassle. Easy to service air cleaner has secondary filter for cleaner intake air and longer engine life.

Water Tanks

New translucent tanks provide a quick view of water level and have a lower profile look with long-lasting reservoir support for durability.

Operator Comfort

Operator area features a certified roll over protection structure, easy-to-use entrance steps and a new style, comfortable, adjustable seat with arm rests. Automotive-style foot pedal provides easy acceleration and dynamic braking. A convenient parking brake with recessed handle is included.



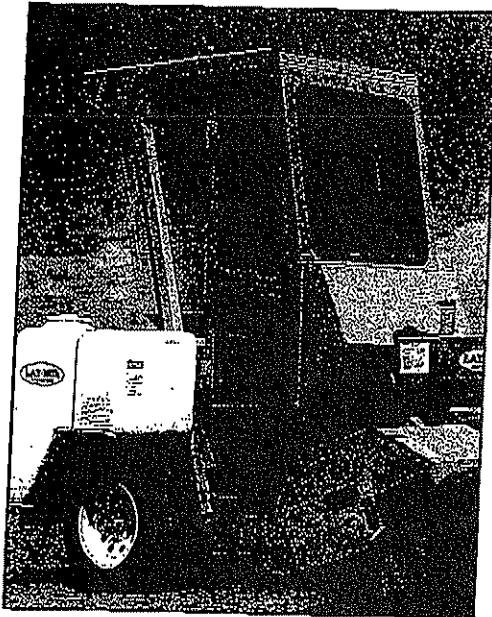

Optional factory installed cab with pressurizer reduces exposure to dust and extreme weather conditions. Includes tinted safety glass windows, 2-speed electric windshield wiper, right and lefthand doors and optional heater with 2-speed blower and defroster fan.



Wide, no-slip honeycomb surface provides less operator fatigue and improved operational comfort.

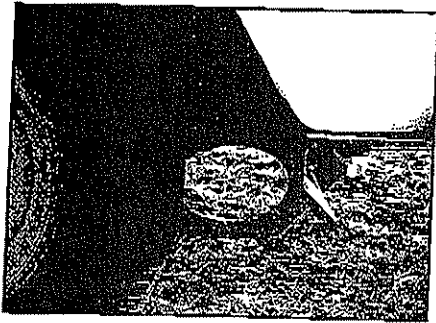

Large, well placed tie down points allow quick and efficient tie down when hauling and prevents damage due to improperly placed restraints.

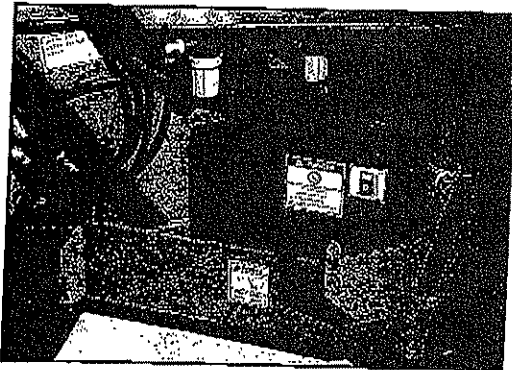

No more fuel sight gauges and hard to clean fuel tanks. The polyethylene fuel tank eliminates rust contamination and is easily removable should fuel become contaminated. The fuel tank features a top mounted mechanical gauge for quick, easy fuel checks.



Protect your investment from accidental customer error when towing by equipping your sweeper with our exclusive optional Hub-Engaged Warning System.

Within a few feet of movement, the system detects if wheel drive motors have not been disengaged, automatically activating a horn and blinking front mounted warning light (shown at left).

A reversed warning decal is also prominently displayed in front of the dash panel, easily recognized by glancing at the operator's rear view mirror.

Cab Option

Automotive style foot pedal

Tie Downs

Fully Accessible Air Cleaner

Optional Hub-Engaged Warning System

201 West Oklahoma Avenue
Fairview, Oklahoma 73737
580-227-3711 • Fax 580-227-2165
www.lay-mor.com

S T A N D A R D E Q U I P M E N T

- 70 Gallon Sprinkler System
- Two-Post ROPS Canopy
- Rear Fenders
- Positive Neutral Start
- Hydraulic Power Steering
- Hydraulic Drum Rear Towing Brakes
- Mechanical Parking Brake
- Gear Motor Final Drive
- P205 75R14 4-Ply Radials
- Automotive-Style Tow Hitch. Includes Surge Brakes, Towing Lights and Wiring Harness
- All Polyethylene Brush, all Steel Wire Brush, or 1/2 and 1/2
- Choice of 2" or 2-5/16" Ball Hitch, or 3" Pintle Hitches
- Omaha Orange Paint
- Steel Broom Core
- Front Debris Deflector
- 9 Gallon Fuel Tank w/Mechanical Gauge
- Cushioned Seat with 2" Retractable Seat Belt & Arm Rests
- Reverse Alarm
- Electric Hour Meter
- Hydraulic Sight Gauge
- Warning Light Package, Engine Oil Pressure, Water Temperature and Alternator
- Engine Protection System

T O W P A C K A G E

- No jack
- One man operation
- All wheels on the ground during towing
- Minimal tongue weight
- Surge brakes
- Towing lights
- Turn signals

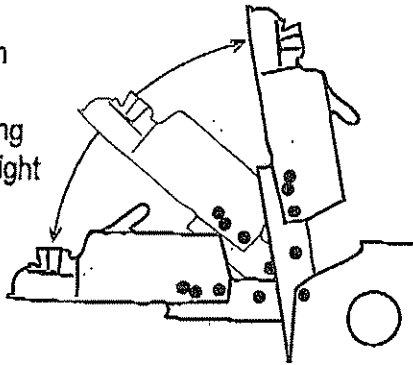

O P T I O N S

- Variable Broom Speed
- Dual Broom Drive Motors
- Special Paint Colors
- Cab (factory installed only)
- Heater
- Available Cat Engine Power
- Defroster
- Strobe Light
- Rotating Beacon
- Work Lights
- Emergency Working and Turn Signal Lights
- Hub-Engaged Warning System

S P E C I F I C A T I O N S

- Engine Kubota V1505 diesel, 37 HP
- Caterpillar 3013 diesel, 31.5 HP
- Broom Size 6-3/8" I.D. x 24" O.D.
- Broom Angle 40° (each way)
- Steering 45° (each way)
- Speed 0 to 7.5 mph
- Machine Weight 6HC 3,000#
- Machine Weight 8HC 3,100#
- Transport Width, Fully Angled 6HC 6'9"
- Transport Width, Fully Angled 8HC 7'10"
- Transport Length, Hitch Down 14'

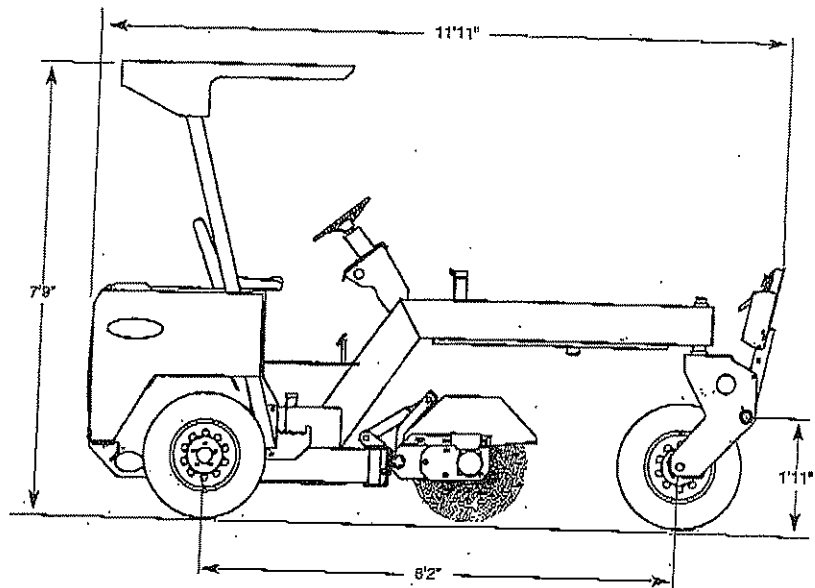

All specifications are in accordance with SAE standards or recommended practices where applicable. Under our policy of improvement, Mobile Products, Inc. reserves the right to modify specifications at any time without prior notice or obligation. Units shown may include optional equipment.
Lay-Mor equipment is manufactured by Mobile Products, Inc.



Kubota Engine Warranty

Kubota warrants to you, the original purchaser, that all parts (except those referred to below) of your new Kubota Industrial engine and replacement parts purchased from an Authorized Kubota Industrial Engine Distributor in Canada will be free from defects in materials or workmanship during the following periods:

1. Industrial Engines for 2 years or 2000 hours from the date of delivery to you except for the following which are warranted for 1 year or 1000 hours: radiator, thermostat, water pump, starter, fuel injection pump, water temperature gauge, fuel lift pump and alternator.
2. Replacement parts for 90 days from the date of installation; or the remainder of the units warranty, whichever is longest.

Kubota will, at its option, repair or replace any part covered by this warranty which is defective, malfunctions or otherwise fails, under normal use, during the term of this warranty, at no charge for parts or labour as indicated in the appropriate flat rate manual.

This warranty does not cover charges for transportation and service calls.

In order to obtain warranty repairs, you must deliver the product, together with proof of purchase, to an Authorized Kubota Power Product Dealer at your expense.

This warranty does not cover:

1. Defects, malfunctions or failures resulting from accidents, abuse, misuse, modifications, alterations, accidents, improper servicing or lack of performance of required maintenance service.
2. Normal maintenance services or replacement of maintenance items such as injector tips, spark plugs, glow plugs, indicator and resistance coils, filter elements, lubricants, oils, and coolants, etc.
3. Premature wear, etc. resulting from incorrect application of the product.
4. Nihon CAV injection pumps are covered by separate warranties issued by their manufacturer or distributor.
5. Damage to the engine or its required attachments due to incorrect application, mounting design or method.
6. Transportation and service call charges.

This is the only express warranty on Kubota Power Products.

Kubota Canada Ltd. does not authorize any other party, including Kubota Industrial Engine Distributors to make any representation or promise on behalf of Kubota Canada Ltd. to modify the terms, conditions or limitations of this warranty in any way.

Kubota's responsibility is to repair or replace defective parts as stated above. Kubota will not be responsible for any other expenses, losses or inconvenience which you may sustain as a result of the purchase, use, malfunction or defective condition of Kubota products.

Kubota's responsibility for any and all losses and damages resulting from any cause whatsoever, including Kubota's negligence, alleged damage or defective goods, whether such defects are discoverable or latent, shall be limited to the repair or replacement of defective parts as stated above. In no event will Kubota be liable for loss of use, loss of profits, loss of or damage to related equipment, inconvenience, commercial loss, or other incidental or consequential damages whatsoever. Some Provinces do not allow limitations on how long an implied warranty lasts or the exclusion or limitation of incidental or consequential damages, so the above limitations or exclusions may not apply to you.