



State of West Virginia  
 Department of Administration  
 Purchasing Division  
 2019 Washington Street East  
 Post Office Box 50130  
 Charleston, WV 25305-0130

# Request for Quotation

RFQ NUMBER  
**05900165**

PAGE  
**1**

ADDRESS CORRESPONDENCE TO ATTENTION OF  
**MICHAEL AUSTIN  
 304-558-2402**

VENDOR

RFQ COPY  
 TYPE NAME/ADDRESS HERE  
*A.L.L. Construction Inc,  
 PO Box 92  
 MT. STORM WV 26739*

SHIP TO

DIVISION OF HIGHWAYS  
 JOBSITE  
 SEE SPECIFICATIONS

DATE PRINTED	TERMS OF SALE	SHIP VIA	FOB	FREIGHT TERMS
09/23/2008				

BID OPENING DATE: **10/15/2008** BID OPENING TIME **01:30PM**

LINE	QUANTITY	UOP	CAT NO	ITEM NUMBER	UNIT PRICE	AMOUNT
0001	1	EA		150-35		<i>A</i> 129,840.00
<p>CONSTRUCT CONCRETE PORTION OF MIX SHED</p> <p>TO CONSTRUCT CONCRETE PORTION OF MIX SHED FOR THE WEST VIRGINIA DIVISION OF HIGHWAYS PER THE ATTACHED SPECIFICATIONS.</p> <p>EXHIBIT 5</p> <p>WEST VIRGINIA CODE 21-1D-5 PROVIDES THAT: ANY SOLICITATION FOR A PUBLIC IMPROVEMENT CONSTRUCTION CONTRACT REQUIRES EACH VENDOR THAT SUBMITS A BID FOR THE WORK TO SUBMIT AT THE SAME TIME AN AFFIDAVIT OF COMPLIANCE WITH THE BID. THE ENCLOSED PURCHASING AFFIDAVIT MUST BE SIGNED AND SUBMITTED WITH THE BID AS EVIDENCE OF THE VENDOR'S COMPLIANCE WITH THE PROVISIONS OF ARTICLE 1D, CHAPTER 21 OF THE WEST VIRGINIA CODE. FAILURE TO SUBMIT THE SIGNED PURCHASING AFFIDAVIT WITH THE BID SHALL RESULT IN DISQUALIFICATION OF SUCH BID.</p> <p>NOTICE TO PROCEED: THIS CONTRACT IS TO BE PERFORMED WITHIN 90 CALENDAR DAYS AFTER THE NOTICE TO PROCEED IS RECEIVED. UNLESS OTHERWISE SPECIFIED, THE FULLY EXECUTED PURCHASE ORDER WILL BE CONSIDERED NOTICE TO PROCEED.</p> <p>CANCELLATION: THE DIRECTOR OF PURCHASING RESERVES THE RIGHT TO CANCEL THIS CONTRACT IMMEDIATELY UPON WRITTEN NOTICE TO THE VENDOR IF THE MATERIALS OR WORKMANSHIP SUPPLIED ARE OF AN INFERIOR QUALITY OR DO NOT CONFORM WITH THE SPECIFICATIONS OF THE BID AND CONTRACT HERE IN.</p>						

RECEIVED  
 08 OCT 14 AM 10:08  
 PURCHASING DIVISION  
 STATE OF WV

SEE REVERSE SIDE FOR TERMS AND CONDITIONS

SIGNATURE <i>[Signature]</i>	TELEPHONE 304-693-7131	DATE 10/11/08
TITLE <i>[Signature]</i>	FEIN 550700300	ADDRESS CHANGES TO BE NOTED ABOVE

WHEN RESPONDING TO RFQ, INSERT NAME AND ADDRESS IN SPACE ABOVE LABELED 'VENDOR'

**GENERAL TERMS & CONDITIONS  
REQUEST FOR QUOTATION (RFQ) AND REQUEST FOR PROPOSAL (RFP)**

1. Awards will be made in the best interest of the State of West Virginia
2. The State may accept or reject in part, or in whole, any bid.
3. All quotations are governed by the *West Virginia Code* and the *Legislative Rules* of the Purchasing Division.
4. Prior to any award, the apparent successful vendor must be properly registered with the Purchasing Division and have paid the required \$125 fee.
5. All services performed or goods delivered under State Purchase Order/Contracts are to be continued for the term of the Purchase Order/Contracts, contingent upon funds being appropriated by the Legislature or otherwise being made available. In the event funds are not appropriated or otherwise available for these services or goods, this Purchase Order/Contract becomes void and of no effect after June 30.
6. Payment may only be made after the delivery and acceptance of goods or services
7. Interest may be paid for late payment in accordance with the *West Virginia Code*
8. Vendor preference will be granted upon written request in accordance with the *West Virginia Code*.
9. The State of West Virginia is exempt from federal and state taxes and will not pay or reimburse such taxes.
10. The Director of Purchasing may cancel any Purchase Order/Contract upon 30 days written notice to the seller.
11. The laws of the State of West Virginia and the *Legislative Rules* of the Purchasing Division shall govern all rights and duties under the Contract, including without limitation the validity of this Purchase Order/Contract.
12. Any reference to automatic renewal is hereby deleted. The Contract may be renewed only upon mutual written agreement of the parties.
13. **BANKRUPTCY:** In the event the vendor/contractor files for bankruptcy protection, this Contract may be deemed null and void, and terminated without further order.
14. **HIPAA BUSINESS ASSOCIATE ADDENDUM:** The West Virginia State Government HIPAA Business Associate Addendum (BAA), approved by the Attorney General, and available online at the Purchasing Division's web site (<http://www.state.wv.us/admin/purchase/vrc/hipaa.htm>) is hereby made part of the agreement. Provided that, the Agency meets the definition of a Cover Entity (45 CFR §160.103) and will be disclosing Protected Health Information (45 CFR §160.103) to the vendor.
15. **WEST VIRGINIA ALCOHOL & DRUG-FREE WORKPLACE ACT:** If this Contract constitutes a public improvement construction contract as set forth in Article 1D, Chapter 21 of the West Virginia Code ("The West Virginia Alcohol and Drug-Free Workplace Act"), then the following language shall hereby become part of this Contract: "The contractor and its subcontractors shall implement and maintain a written drug-free workplace policy in compliance with the West Virginia Alcohol and Drug-Free Workplace Act, as set forth in Article 1D, Chapter 21 of the West Virginia Code. The contractor and its subcontractors shall provide a sworn statement in writing, under the penalties of perjury, that they maintain a valid drug-free work place policy in compliance with the West Virginia and Drug-Free Workplace Act. It is understood and agreed that this Contract shall be cancelled by the awarding authority if the Contractor: 1) Fails to implement its drug-free workplace policy; 2) Fails to provide information regarding implementation of the contractor's drug-free workplace policy at the request of the public authority; or 3) Provides to the public authority false information regarding the contractor's drug-free workplace policy."

---

**INSTRUCTIONS TO BIDDERS**

1. Use the quotation forms provided by the Purchasing Division.
2. **SPECIFICATIONS:** Items offered must be in compliance with the specifications. Any deviation from the specifications must be clearly indicated by the bidder. Alternates offered by the bidder as **EQUAL** to the specifications must be clearly defined. A bidder offering an alternate should attach complete specifications and literature to the bid. The Purchasing Division may waive minor deviations to specifications.
3. Complete all sections of the quotation form.
4. Unit prices shall prevail in case of discrepancy.
5. All quotations are considered F.O.B. destination unless alternate shipping terms are clearly identified in the quotation.
6. **BID SUBMISSION:** All quotations must be delivered by the bidder to the office listed below prior to the date and time of the bid opening. Failure of the bidder to deliver the quotations on time will result in bid disqualifications: Department of Administration, Purchasing Division, 2019 Washington Street East, P.O. Box 50130, Charleston, WV 25305-0130



State of West Virginia  
 Department of Administration  
 Purchasing Division  
 2019 Washington Street East  
 Post Office Box 50130  
 Charleston, WV 25305-0130

**Request for  
 Quotation**

RFQ NUMBER  
**05900165**

PAGE  
**2**

ADDRESS CORRESPONDENCE TO ATTENTION OF:  
**MICHAEL AUSTIN  
 304-558-2402**

RFQ COPY  
 TYPE NAME/ADDRESS HERE

V  
E  
N  
D  
O  
R

S  
H  
I  
P  
I  
O

DIVISION OF HIGHWAYS  
 JOBSITE  
 SEE SPECIFICATIONS

DATE PRINTED <b>09/23/2008</b>	TERMS OF SALE	SHIP VIA	FOB	FREIGHT TERMS
-----------------------------------	---------------	----------	-----	---------------

BID OPENING DATE: **10/15/2008** BID OPENING TIME **01:30PM**

LINE	QUANTITY	UOP	CAT. NO.	ITEM NUMBER	UNIT PRICE	AMOUNT
<p><b>WAGE RATES: THE CONTRACTOR OR SUBCONTRACTOR SHALL PAY THE HIGHER OF THE U.S. DEPARTMENT OF LABOR MINIMUM WAGE RATES AS ESTABLISHED FOR MINERAL COUNTY, PURSUANT TO WEST VIRGINIA CODE 21-5A, ET, SEQ. (PREVAILING WAGE RATES APPLY TO THIS PROJECT)</b></p> <p><b>ARBITRATION: ANY REFERENCES MADE TO ARBITRATION OR INTEREST FOR PAYMENTS DUE (EXCEPT FOR ANY INTEREST REQUIRED BY STATE LAW) CONTAINED IN THIS CONTRACT OR IN ANY AMERICAN INSTITUTE OF ARCHITECTS DOCUMENTS PERTAINING TO THIS CONTRACT ARE HEREBY DELETED.</b></p> <p><b>WORKERS' COMPENSATION: VENDOR IS REQUIRED TO PROVIDE A CERTIFICATE FROM WORKERS' COMPENSATION IF SUCCESSFUL.</b></p> <p><b>ALL OF THE ITEMS CHECKED BELOW WILL BE A REQUIREMENT OF THIS CONTRACT:</b></p> <p><b>(XX) INSURANCE: SUCCESSFUL VENDOR SHALL FURNISH PROOF OF COMMERCIAL GENERAL LIABILITY INSURANCE PRIOR TO ISSUANCE OF CONTRACT. UNLESS OTHERWISE SPECIFIED IN THE BID DOCUMENTS, THE MINIMUM AMOUNT OF INSURANCE COVERAGE REQUIRED IS \$250,000.</b></p> <p><b>( ) BUILDERS RISK INSURANCE: SUCCESSFUL VENDOR SHALL FURNISH PROOF OF BUILDERS RISK - ALL RISK INSURANCE IN AN AMOUNT EQUAL TO 100% OF THE AMOUNT OF THE CONTRACT.</b></p> <p><b>(XX) BONDS: FIVE PERCENT (5%) OF THE TOTAL AMOUNT OF THE BID PAYABLE TO THE STATE OF WEST VIRGINIA, SHALL BE SUBMITTED WITH EACH BID AS A BID BOND. THE SUCCESSFUL BIDDER SHALL ALSO FURNISH A PERFORMANCE BOND AND LABOR/MATERIAL BOND FOR 100% OF THE AMOUNT OF THE CONTRACT. BONDS MAY BE PROVIDED IN THE FORM OF A CERTIFIED CHECK, IRREVOCABLE LETTER OF CREDIT, OR BOND FURNISHED BY A</b></p>						

SEE REVERSE SIDE FOR TERMS AND CONDITIONS

SIGNATURE 	TELEPHONE <b>304-693-7131</b>	DATE <b>10/16/08</b>
TITLE <b>VP</b>	FERN <b>550700300</b>	ADDRESS CHANGES TO BE NOTED ABOVE

WHEN RESPONDING TO RFQ, INSERT NAME AND ADDRESS IN SPACE ABOVE LABELED 'VENDOR'



State of West Virginia  
 Department of Administration  
 Purchasing Division  
 2019 Washington Street East  
 Post Office Box 50130  
 Charleston, WV 25305-0130

# Request for Quotation

RFQ NUMBER  
**05900165**

PAGE  
**3**

ADDRESS CORRESPONDENCE TO ATTENTION OF:  
**MICHAEL AUSTIN  
 304-558-2402**

RFQ COPY  
 TYPE NAME/ADDRESS HERE

DIVISION OF HIGHWAYS  
 JOBSITE  
 SEE SPECIFICATIONS

DATE PRINTED	TERMS OF SALE	SHIP VIA	F.O.B.	FREIGHT TERMS
09/23/2008				

BID OPENING DATE: **10/15/2008** BID OPENING TIME **01:30PM**

LINE	QUANTITY	UOP	CAT NO.	ITEM NUMBER	UNIT PRICE	AMOUNT
<p>SOLVENT SURETY COMPANY AUTHORIZED TO DO BUSINESS IN THE STATE OF WEST VIRGINIA. A LETTER OF CREDIT SUBMITTED IN LIEU OF A BOND WILL ONLY BE ALLOWED FOR PROJECTS UNDER \$100,000. PERSONAL OR BUSINESS CHECKS ARE NOT ACCEPCTABLE IN LIEU OF THE 5% BID BOND, PERFORMANCE BOND, OR LABOR AND MATERIAL BOND.</p> <p>(XX) MAINTENANCE BOND: A TWO (2) YEAR MAINTENANCE BOND COVERING THE ROOFING SYSTEM WILL BE A REQUIREMENT OF THE SUCCESSFUL VENDOR.</p> <p>REV. 11/00</p> <p>EXHIBIT 7</p> <p>DOMESTIC ALUMINUM, GLASS &amp; STEEL IN PUBLIC WORKS PROJECTS</p> <p>IN ACCORDANCE WITH WEST VIRGINIA CODE 5-19-1 ET., SEQ., EVERY CONTRACT FOR CONSTRUCTION, RECONSTRUCTION, ALTERATION, REPAIR, IMPROVEMENT OR MAINTENANCE OF PUBLIC WORKS, WHERE THE COST IS MORE THAN \$50,000 AND, IN THE CASE OF STEEL ONLY, WHERE THE COST OF STEEL IS MORE THAN \$50,000 OR WHERE MORE THAN 10,000 POUNDS OF STEEL ARE REQUIRED, THE STATE WILL ACCEPT ONLY ALUMINUM GLASS, OR STEEL PRODUCTS PRODUCED IN THE UNITED STATES. IN ADDITION, ITEMS OF MACHINERY OR EQUIPMENT PURCHASED FOR USE AT THE SITE OF PUBLIC WORKS SHALL BE MADE OF DOMESTIC ALUMINUM, GLASS OR STEEL, UNLESS THE COST OF THE PRODUCT IS LESS THAN \$50,000 OR LESS THAN 10,000 POUNDS OF STEEL ARE USED IN PUBLIC WORKS PROJECTS.</p> <p>FOREIGN MADE ALUMINUM, GLASS OR STEEL PRODUCTS MAY BE ACCEPTED ONLY IF THE COST OF DOMESTIC PRODUCTS IS FOUND TO BE UNREASONABLE. SUCH COST IS UNREASONABLE IF IT I</p>						

SEE REVERSE SIDE FOR TERMS AND CONDITIONS

SIGNATURE	TELEPHONE <b>304-693-7131</b>	DATE <b>10/11/08</b>
TITLE <b>VP</b>	FEIN <b>550700300</b>	ADDRESS CHANGES TO BE NOTED ABOVE

WHEN RESPONDING TO RFQ, INSERT NAME AND ADDRESS IN SPACE ABOVE LABELED 'VENDOR'



State of West Virginia  
 Department of Administration  
 Purchasing Division  
 2019 Washington Street East  
 Post Office Box 50130  
 Charleston, WV 25305-0130

# Request for Quotation

RFQ NUMBER  
**05900165**

PAGE  
**4**

ADDRESS CORRESPONDENCE TO ATTENTION OF  
**MICHAEL AUSTIN  
 304-558-2402**

RFQ COPY  
 TYPE NAME/ADDRESS HERE

DIVISION OF HIGHWAYS  
 JOBSITE  
 SEE SPECIFICATIONS

DATE PRINTED <b>09/23/2008</b>	TERMS OF SALE	SHIP VIA	F.O.B.	FREIGHT TERMS
-----------------------------------	---------------	----------	--------	---------------

BID OPENING DATE: **10/15/2008** BID OPENING TIME **01:30PM**

LINE	QUANTITY	UOP	CAT NO	ITEM NUMBER	UNIT PRICE	AMOUNT
<p>20% OR MORE HIGHER THAN THE BID PRICE FOR FOREIGN MADE PRODUCTS. IF THE DOMESTIC ALUMINUM, GLASS OR STEEL PRODUCTS TO BE SUPPLIED OR PRODUCED IN A "SUBSTANTIAL LABOR SURPLUS AREA", AS DEFINED BY THE UNITED STATES DEPARTMENT OF LABOR, FOREIGN PRODUCTS MAY BE SUPPLIED ONLY IF DOMESTIC PRODUCTS ARE 30% OR MORE HIGHER IN PRICE THAN THE FOREIGN MADE PRODUCTS.</p> <p>IF, PRIOR TO THE AWARD OF A CONTRACT UNDER THE ABOVE PROVISIONS, THE SPENDING OFFICER OF THE SPENDING UNIT DETERMINES THAT THERE EXISTS A BID FOR LIKE FOREIGN ALUMINUM, GLASS OR STEEL THAT IS REASONABLE AND LOWER THAN THE LOWEST BID DOMESTIC PRODUCTS, THE SPENDING OFFICE MAY REQUEST, IN WRITING, A REEVALUATION AND REDUCTION IN THE LOWEST BID FOR SUCH DOMESTIC PRODUCTS. ALL VENDORS MUST INDICATE IN THEIR BID IF THEY ARE SUPPLYING FOREIGN ALUMINUM, GLASS OR STEEL.</p> <p>REV. 3/88</p> <p>EXHIBIT 9</p> <p>NOTICE FOR ISSUANCE &amp; ACKNOWLEDGEMENT OF CONSTRUCTION PROJECT ADDENDA</p> <p>THE ARCHITECT/ENGINEER AND/OR AGENCY SHALL BE REQUIRED TO ABIDE BY THE FOLLOWING SCHEDULE IN ISSUING CONSTRUCTION PROJECT ADDENDA FOR STATE AGENCIES:</p> <p>(1) THE ARCHITECT/ENGINEER SHALL PREPARE THE ADDENDUM AND A LIST OF ALL PARTIES THAT HAVE PROCURED DRAWINGS AND SPECIFICATIONS FOR THE PROJECT. THE ADDENDUM AND LIST SHALL BE FORWARDED TO THE BUYER IN THE STATE PURCHASING DIVISION. THE ARCHITECT/ENGINEER SHALL ALSO SEND A COPY OF THE ADDENDUM TO THE STATE AGENCY FOR</p>						
SEE REVERSE SIDE FOR TERMS AND CONDITIONS						

SIGNATURE 	TELEPHONE <b>304-693-7131</b>	DATE <b>10/11/08</b>
TITLE <b>VP</b>	FEIN <b>550700300</b>	ADDRESS CHANGES TO BE NOTED ABOVE

WHEN RESPONDING TO RFQ, INSERT NAME AND ADDRESS IN SPACE ABOVE LABELED 'VENDOR'



State of West Virginia  
 Department of Administration  
 Purchasing Division  
 2019 Washington Street East  
 Post Office Box 50130  
 Charleston, WV 25305-0130

# Request for Quotation

RFQ NUMBER  
**05900165**

PAGE  
**5**

ADDRESS CORRESPONDENCE TO ATTENTION OF  
**MICHAEL AUSTIN  
 304-558-2402**

RFQ COPY  
 TYPE NAME/ADDRESS HERE

DIVISION OF HIGHWAYS  
 JOBSITE  
 SEE SPECIFICATIONS

DATE PRINTED	TERMS OF SALE	SHIP VIA	FOB	FREIGHT TERMS
09/23/2008				

BID OPENING DATE: **10/15/2008** BID OPENING TIME **01:30PM**

LINE	QUANTITY	UQP	CAT NO	ITEM NUMBER	UNIT PRICE	AMOUNT
<p>WHICH THE CONTRACT IS ISSUED.</p> <p>(2) THE BUYER SHALL SEND THE ADDENDUM TO ALL INTERESTED PARTIES AND, IF NECESSARY, EXTEND THE BID OPENING DATE. ANY ADDENDUM SHOULD BE RECEIVED BY THE BUYER WITHIN FOURTEEN (14) DAYS PRIOR TO THE BID OPENING DATE.</p> <p>(3) ALL ADDENDA SHOULD BE FORMALLY ACKNOWLEDGED BY ALL BIDDERS AND SUBMITTED TO THE STATE PURCHASING DIVISION. THE SAME RULES AND REGULATIONS THAT APPLY TO THE ORIGINAL BIDDING DOCUMENT SHALL ALSO APPLY TO AN ADDENDUM DOCUMENT. THE ONLY EXCEPTION MAY BE FOR AN ADDENDUM THAT IS ISSUED FOR THE SOLE PURPOSE OF CHANGING A BID OPENING TIME AND/OR DATE.</p> <p>REV. 11/96</p> <p>EXHIBIT 10</p> <p>ADDENDUM ACKNOWLEDGEMENT</p> <p>I HEREBY ACKNOWLEDGE RECEIPT OF THE FOLLOWING CHECKED ADDENDUM(S) AND HAVE MADE THE NECESSARY REVISIONS TO MY PROPOSAL, PLANS AND/OR SPECIFICATION, ETC.</p> <p>ADDENDUM NOS.:</p> <p>NO. 1 .....</p> <p>NO. 2 .....</p> <p>NO. 3 .....</p>						

SEE REVERSE SIDE FOR TERMS AND CONDITIONS

SIGNATURE 	TELEPHONE 304-693-731	DATE 10/11/08
TITLE 	FEIN 580700300	ADDRESS CHANGES TO BE NOTED ABOVE

WHEN RESPONDING TO RFQ, INSERT NAME AND ADDRESS IN SPACE ABOVE LABELED 'VENDOR'



State of West Virginia  
 Department of Administration  
 Purchasing Division  
 2019 Washington Street East  
 Post Office Box 50130  
 Charleston, WV 25305-0130

**Request for  
 Quotation**

RFQ NUMBER  
**05900165**

PAGE  
**6**

ADDRESS CORRESPONDENCE TO ATTENTION OF  
**MICHAEL AUSTIN  
 304-558-2402**

SUBJECT

RFQ COPY  
 TYPE NAME/ADDRESS HERE

SHIP TO

DIVISION OF HIGHWAYS  
 JOBSITE  
 SEE SPECIFICATIONS

DATE PRINTED <b>09/23/2008</b>	TERMS OF SALE	SHIP VIA	F.C.B.	FREIGHT TERMS
BID OPENING DATE: <b>10/15/2008</b>		BID OPENING TIME <b>01:30PM</b>		

LINE	QUANTITY	UOP	CAT NO	ITEM NUMBER	UNIT PRICE	AMOUNT
	NO. 4	.....				
	NO. 5	.....				
<p>I UNDERSTAND THAT FAILURE TO CONFIRM THE RECEIPT OF THE ADDENDUM(S) MAY BE CAUSE FOR REJECTION OF THE BIDS.</p> <p>VENDOR MUST CLEARLY UNDERSTAND THAT ANY VERBAL REPRESENTATION MADE OR ASSUMED TO BE MADE DURING ANY ORAL DISCUSSION HELD BETWEEN VENDOR'S REPRESENTATIVES AND ANY STATE PERSONNEL IS NOT BINDING. ONLY THE INFORMATION ISSUED IN WRITING AND ADDED TO THE SPECIFICATIONS BY AN OFFICIAL ADDENDUM IS BINDING.</p> <p>.....SIGNATURE  <i>A.L.L. Construction Inc.</i>            .....COMPANY            .....10/11/08.....DATE</p> <p>REV. 11/96</p> <p>CONTRACTORS LICENSE</p> <p>WEST VIRGINIA STATE CODE 21-11-2 REQUIRES THAT ALL PERSONS DESIRING TO PERFORM CONTRACTING WORK IN THIS STATE MUST BE LICENSED. THE WEST VIRGINIA CONTRACTORS LICENSING BOARD IS EMPOWERED TO ISSUE THE CONTRACTORS LICENSE. APPLICATIONS FOR A CONTRACTORS LICENSE MAY BE MADE BY CONTACTING THE WEST VIRGINIA DIVISION OF LABOR CAPITOL COMPLEX, BUILDING 3, ROOM 319, CHARLESTON, WV 25305. TELEPHONE: (304) 558-7890.</p> <p>WEST VIRGINIA STATE CODE 21-11-11 REQUIRES ANY</p>						

SEE REVERSE SIDE FOR TERMS AND CONDITIONS

SIGNATURE *[Signature]* TELEPHONE **304-693-7131** DATE **10/11/08**

TITLE **VP** FEIN **550700300** ADDRESS CHANGES TO BE NOTED ABOVE

WHEN RESPONDING TO RFQ, INSERT NAME AND ADDRESS IN SPACE ABOVE LABELED 'VENDOR'



State of West Virginia  
 Department of Administration  
 Purchasing Division  
 2019 Washington Street East  
 Post Office Box 50130  
 Charleston, WV 25305-0130

# Request for Quotation

RFQ NUMBER  
**05900165**

PAGE  
**7**

ADDRESS CORRESPONDENCE TO ATTENTION OF  
**MICHAEL AUSTIN  
 304-558-2402**

RFQ COPY  
 TYPE NAME/ADDRESS HERE

VENDOR

SHIP TO

**DIVISION OF HIGHWAYS  
 JOBSITE  
 SEE SPECIFICATIONS**

DATE PRINTED	TERMS OF SALE	SHIP VIA	FOB	FREIGHT TERMS
<b>09/23/2008</b>				

BID OPENING DATE: **10/15/2008** BID OPENING TIME **01:30PM**

LINE	QUANTITY	UOP	CAT NO	ITEM NUMBER	UNIT PRICE	AMOUNT
<p>PROSPECTIVE BIDDER TO INCLUDE THE CONTRACTORS LICENSE NUMBER ON THEIR BID.</p> <p>BIDDER TO COMPLETE:</p> <p>CONTRACTORS NAME: ... <i>A.H.L. Construction, Inc.</i> ...</p> <p>CONTRACTORS LICENSE NO.: ... <i>WV 010638</i> ...</p> <p>THE SUCCESSFUL BIDDER WILL BE REQUIRED TO FURNISH A COPY OF THEIR CONTRACTORS LICENSE PRIOR TO ISSUANCE OF A PURCHASE ORDER/CONTRACT</p> <p style="text-align: center;">APPLICABLE LAW</p> <p>THE WEST VIRGINIA STATE CODE, PURCHASING DIVISION RULES AND REGULATIONS, AND THE INFORMATION PROVIDED IN THE "REQUEST FOR QUOTATION" ISSUED BY THE PURCHASING DIVISION IS THE SOLE AUTHORITY GOVERNING THIS PROCUREMENT.</p> <p>ANY INFORMATION PROVIDED IN SPECIFICATION MANUALS, OR ANY OTHER SOURCE, VERBAL OR WRITTEN, WHICH CONTRADICTS OR ALTERS THE INFORMATION PROVIDED FROM THE SOURCES AS DESCRIBED IN THE ABOVE PARAGRAPH IS VOID AND OF NO EFFECT.</p> <p>BANKRUPTCY: IN THE EVENT THE VENDOR/CONTRACTOR FILES FOR BANKRUPTCY PROTECTION, THIS CONTRACT IS AUTOMATICALLY NULL AND VOID, AND IS TERMINATED WITHOUT FURTHER ORDER.</p> <p>REV. 1/2005</p> <p style="text-align: center;">NOTICE</p>						

SEE REVERSE SIDE FOR TERMS AND CONDITIONS

SIGNATURE <i>[Signature]</i>	TELEPHONE <b>304-693-7371</b>	DATE <b>10/11/08</b>
TITLE <i>[Signature]</i>	FEN <b>550706300</b>	ADDRESS CHANGES TO BE NOTED ABOVE

WHEN RESPONDING TO RFQ, INSERT NAME AND ADDRESS IN SPACE ABOVE LABELED 'VENDOR'





State of West Virginia  
 Department of Administration  
 Purchasing Division  
 2019 Washington Street East  
 Post Office Box 50130  
 Charleston, WV 25305-0130

# Request for Quotation

RFQ NUMBER  
**05900165**

PAGE  
**8**

ADDRESS CORRESPONDENCE TO ATTENTION OF:  
**MICHAEL AUSTIN  
 304-558-2402**

RFQ COPY  
 TYPE NAME/ADDRESS HERE

DIVISION OF HIGHWAYS  
 JOBSITE  
 SEE SPECIFICATIONS

DATE PRINTED	TERMS OF SALE	SHIP VIA	F.O.B.	FREIGHT TERMS
09/23/2008				

BID OPENING DATE: **10/15/2008** BID OPENING TIME **01:30PM**

LINE	QUANTITY	UOP	CAT NO	ITEM NUMBER	UNIT PRICE	AMOUNT
<p>A SIGNED BID MUST BE SUBMITTED TO:</p> <p>DEPARTMENT OF ADMINISTRATION            PURCHASING DIVISION            BUILDING 15            2019 WASHINGTON STREET, EAST            CHARLESTON, WV 25305-0130</p> <p>THE BID SHOULD CONTAIN THIS INFORMATION ON THE FACE OF THE ENVELOPE OR THE BID MAY NOT BE CONSIDERED:</p> <p>SEALED BID</p> <p>BUYER: <b>33</b></p> <p>REQ. NO.: <b>05900165</b></p> <p>BID OPENING DATE: <b>10/15/08</b></p> <p>BID OPENING TIME: <b>1:30 pm</b></p> <p>PLEASE PROVIDE A FAX NUMBER IN CASE IT IS NECESSARY TO CONTACT YOU REGARDING YOUR BID:  <b>304-693-7199</b></p> <p>PLEASE PRINT OR TYPE NAME OF PERSON TO CONTACT CONCERNING THIS QUOTE:  <b>Jason Kitzmiller</b></p>						

SEE REVERSE SIDE FOR TERMS AND CONDITIONS

SIGNATURE <i>[Signature]</i>	TELEPHONE <b>304-693-7191</b>	DATE <b>10/11/08</b>
TITLE <b>VP</b>	FAX <b>550 700 300</b>	ADDRESS CHANGES TO BE NOTED ABOVE

WHEN RESPONDING TO RFQ, INSERT NAME AND ADDRESS IN SPACE ABOVE LABELED 'VENDOR'



State of West Virginia  
 Department of Administration  
 Purchasing Division  
 2019 Washington Street East  
 Post Office Box 50130  
 Charleston, WV 25305-0130

# Request for Quotation

RFQ NUMBER  
**05900165**

PAGE  
**9**

ADDRESS CORRESPONDENCE TO ATTENTION OF  
**MICHAEL AUSTIN**  
**304-558-2402**

RFQ COPY  
 TYPE NAME/ADDRESS HERE

DIVISION OF HIGHWAYS  
 JOBSITE  
 SEE SPECIFICATIONS

RFQ COPY

SHIP TO

DATE PRINTED	TERMS OF SALE	SHIP VIA	F.O.B.	FREIGHT TERMS
09/23/2008				

BID OPENING DATE: **10/15/2008** BID OPENING TIME **01:30PM**

LINE	QUANTITY	UOP	CAT NO	ITEM NUMBER	UNIT PRICE	AMOUNT
***** THIS IS THE END OF RFQ 05900165 ***** TOTAL:						\$ <u>129,840.00</u>

SEE REVERSE SIDE FOR TERMS AND CONDITIONS

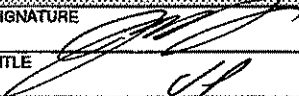
SIGNATURE:  TELEPHONE: **304-693-7131** DATE: **10/11/08**

TITLE:  FEIN: **550700300** ADDRESS CHANGES TO BE NOTED ABOVE

WHEN RESPONDING TO RFQ, INSERT NAME AND ADDRESS IN SPACE ABOVE LABELED 'VENDOR'

TO CONSTRUCT A 30' X 30' CONCRETE PORTION OF A MIX SHED AT WV DEPT. OF HIGHWAYS, MINERAL COUNTY SUB STATION, SHORT GAP, WV INCLUDING FOOTINGS, WALL, FLOOR, AND APRON. THE WORK IS TO INCLUDE ALL MATERIALS, LABOR, NECESSARY FORMS AND TOOLS TO COMPLETE THE CAST-IN-PLACE STRUCTURE.

SEE ATTACHED SHEET FOR SPECIFICATIONS

THE WINNING BIDDER SHALL HAVE 90 DAYS FROM THE DATE OF BID AWARDING TO COMPLETE THE WORK

## Specifications

The Contractor shall provide the labor, tools, equipment, and materials necessary to finish and install the cast-in-place concrete in accordance with the plans and as specified herein. This a lump sum bid with the Contractor providing all formwork, hand tools and equipment for proper installation and finishing of all cast-in-place concrete surfaces. The agency will supply the operator and machinery to prepare the sub grade along with any needed stone for leveling purposes. The final grade will be the responsibility of the Contractor.

The work shall be in compliance with the West Virginia Department of Transportation, Division of Highways, Standard Specifications, Roads and Bridges, Adopted 1993, as amended by The West Virginia Department of Highways, supplemental specifications in effect at the time of the contract award.

All concrete shall be Class "B" mix. The Contractor must submit and have an approved mix design before the work is accomplished. No testing of the concrete will be required. The Highway Department may wish to sample the material for final strength to assure mix compliance. All reinforcement bars shall be grade 60. Bolsters, chairs, spacers, and other devices for spacing, supporting, and fastening the bars in place shall also be provided by the Contractor. The Contractor shall accurately position, support, and secure reinforcement against displacement during concrete placement to the satisfaction of the project Engineer. Set wire ties so ends are directed into the concrete and not toward exposed concrete surfaces.

There is no anticipation of any construction joints for the floor slab. The floor and apron slabs shall receive a floated finish followed by a trowel finish consolidating the concrete and producing a level surface free from defects. A non slip rough broom finish applied lateral to vehicle entry will then be applied.

The walls shall be smoothed formed on the inside surface and the exterior can be smooth or brick pattern. Consolidation shall be accomplished thru vibration should produce a texture free from honey combing and voids. Minor patching of smaller defects shall be patched immediately after form removal and not more than three days after the placement date. A key way is to be established between the footing and wall base as per plans. One method is to wrap a 2"x4" in plastic and inset into the footer. Other options may be used as approved by the Engineer.

WEST VIRGINIA DIVISION OF HIGHWAYS

Form DS-27  
1-1-90

ENGINEERING DIVISION  
GENERAL SKETCH SHEET

By: D.J. Date: 3/4/08 Ckd By: Date: Short Gap Mix Bld. Sheet 1 of 3

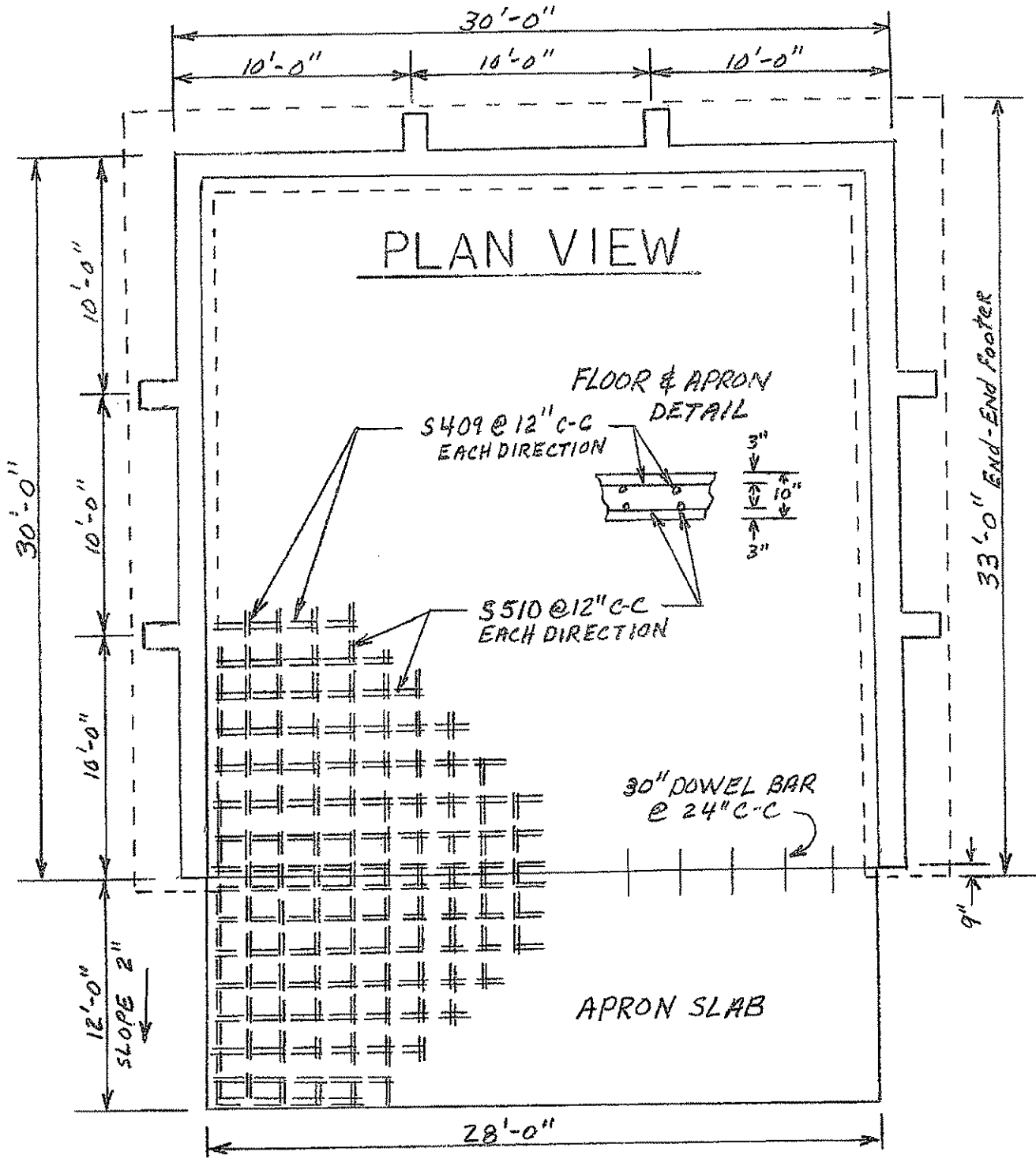

Rev Date:	Rev Date:	Rev Date:	Rev Date:	Rev Date:	Rev Date:
By:	By:	By:	By:	By:	By:

WEST VIRGINIA DIVISION OF HIGHWAYS

Form DS-27  
1-1-90

ENGINEERING DIVISION  
GENERAL SKETCH SHEET

By: D.J. Date: 3/4/08 Ckd By: Date: Short Gap Mix Bld. Sheet 2 of 3

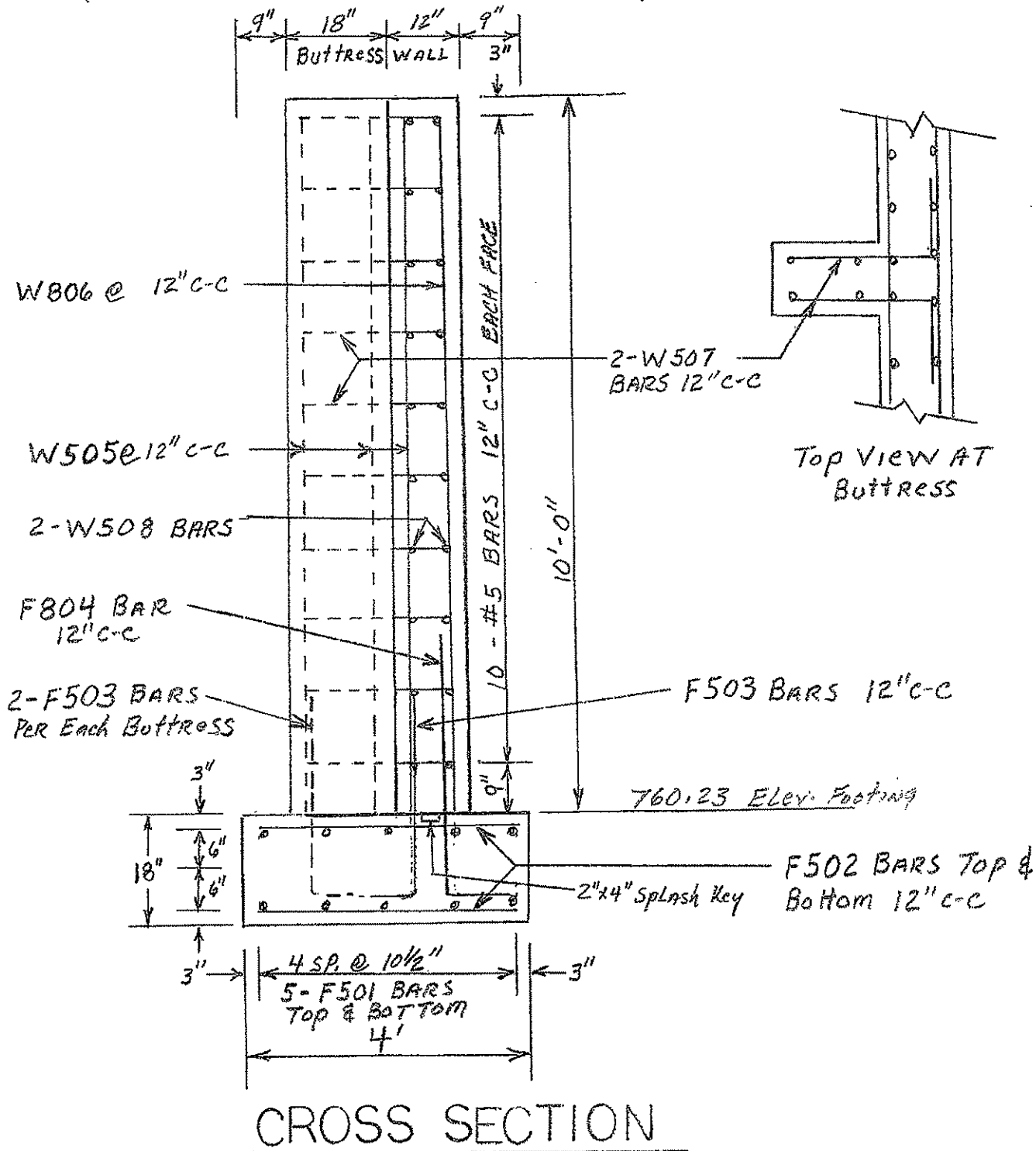

Rev Date:	Rev Date:	Rev Date:	Rev Date:	Rev Date:	Rev Date:
By:	By:	By:	By:	By:	By:

WEST VIRGINIA DIVISION OF HIGHWAYS

Form DS-27  
1-1-90

ENGINEERING DIVISION  
GENERAL SKETCH SHEET

By: D. J.    Date: 3/4/08    Ckd By:    Date:    Short Gap Mix Bld.    Sheet 3 of 3

## BILL OF REINFORCING STEEL

MARK	TYPE	LENGTH EACH	No. BARS	TOTAL WEIGHT	
F501	STR.	20'-0"	49	1,022 Lbs.	
F502	STR.	3'-6"	182	664 Lbs.	
F503	BENT	3'-7"	103	369 Lbs.	
F804	BENT	4'-6"	91	1,093 Lbs.	
W505	STR.	9'-9"	117	1,179 Lbs.	
W806	STR.	9'-9"	91	2,348 Lbs.	
W507	Bent	3'-7"	120	448 Lbs.	
W508	STR.	20'-0"	97	2,023 Lbs.	
S409	STR.	20'-0"	111	1,474 Lbs.	APRON & SLAB
S510	STR.	20'-0"	111	2,315 Lbs.	
				<b>12,935 Lbs. TOTAL</b>	

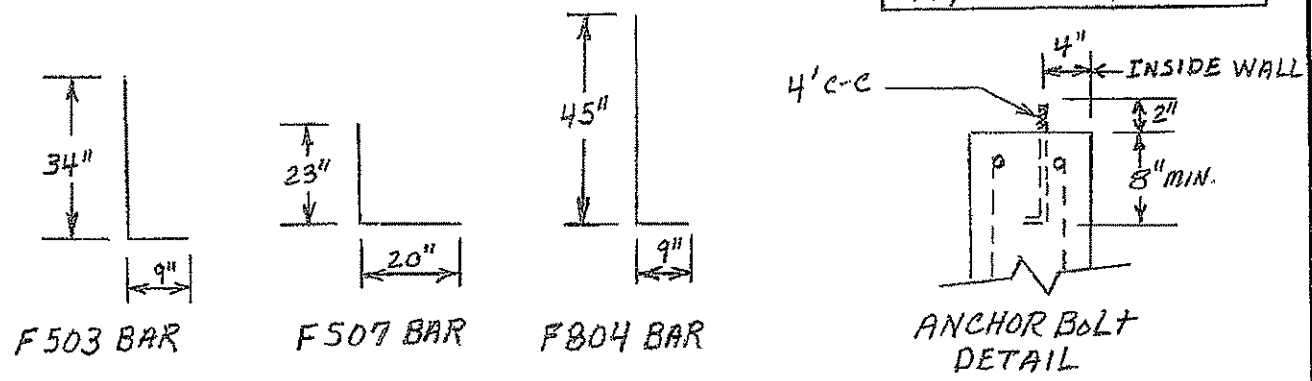

**Notes :**

1. The total yards of concrete is estimated at 88.7 cubic yards of Class B concrete. The estimated total amount of reinforcement is 12,935 lbs. The Contractor is responsible for verifying all quantity estimates, *before ordering.*
2. All reinforcing steel bars shall be covered with a minimum of 3" of concrete at all sides.
3. All reinforcing steel bar splices shall be a minimum of 30 bar diameters.

Rev Date:	Rev Date:	Rev Date:	Rev Date:	Rev Date:	Rev Date:
By:	By:	By:	By:	By:	By:

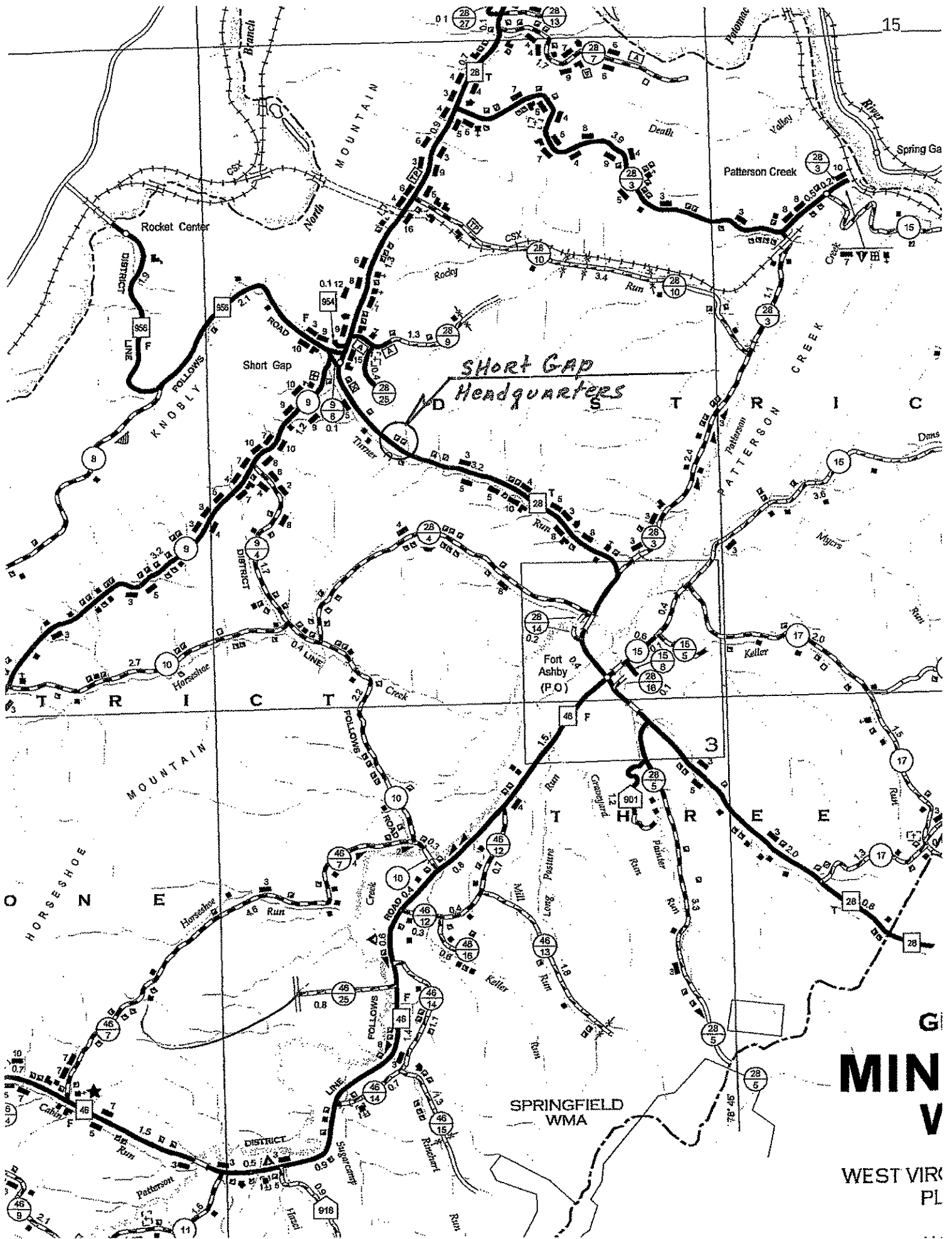

SHORT GAP  
Headquarters

Fort Ashby  
(P.O.)

MIN V  
WEST VIRG  
PL



STATE OF WEST VIRGINIA  
Purchasing Division

**PURCHASING AFFIDAVIT**

**VENDOR OWING A DEBT TO THE STATE:**

*West Virginia Code* §5A-3-10a provides that: No contract or renewal of any contract may be awarded by the state or any of its political subdivisions to any vendor or prospective vendor when the vendor or prospective vendor or a related party to the vendor or prospective vendor is a debtor and the debt owed is an amount greater than one thousand dollars in the aggregate.

**PUBLIC IMPROVEMENT CONTRACTS & DRUG-FREE WORKPLACE ACT:**

*West Virginia Code* §21-1D-5 provides that: Any solicitation for a public improvement construction contract shall require each vendor that submits a bid for the work to submit at the same time an affidavit that the vendor has a written plan for a drug-free workplace policy in compliance with Article 1D, Chapter 21 of the West Virginia Code. A public improvement construction contract may not be awarded to a vendor who does not have a written plan for a drug-free workplace policy in compliance with Article 1D, Chapter 21 of the West Virginia Code and who has not submitted that plan to the appropriate contracting authority in timely fashion. For a vendor who is a subcontractor, compliance with Section 5, Article 1D, Chapter 21 of the West Virginia Code may take place before their work on the public improvement is begun.

**ANTITRUST:**

In submitting a bid to any agency for the state of West Virginia, the bidder offers and agrees that if the bid is accepted the bidder will convey, sell, assign or transfer to the state of West Virginia all rights, title and interest in and to all causes of action it may now or hereafter acquire under the antitrust laws of the United States and the state of West Virginia for price fixing and/or unreasonable restraints of trade relating to the particular commodities or services purchased or acquired by the state of West Virginia. Such assignment shall be made and become effective at the time the purchasing agency tenders the initial payment to the bidder.

I certify that this bid is made without prior understanding, agreement, or connection with any corporation, firm, limited liability company, partnership or person or entity submitting a bid for the same materials, supplies, equipment or services and is in all respects fair and without collusion or fraud. I further certify that I am authorized to sign the certification on behalf of the bidder or this bid.

**LICENSING:**

Vendors must be licensed and in good standing in accordance with any and all state and local laws and requirements by any state or local agency of West Virginia, including, but not limited to, the West Virginia Secretary of State's Office, the West Virginia Tax Department, West Virginia Insurance Commission, or any other state agencies or political subdivision. Furthermore, the vendor must provide all necessary releases to obtain information to enable the Director or spending unit to verify that the vendor is licensed and in good standing with the above entities.

**CONFIDENTIALITY:**

The vendor agrees that he or she will not disclose to anyone, directly or indirectly, any such personally identifiable information or other confidential information gained from the agency, unless the individual who is the subject of the information consents to the disclosure in writing or the disclosure is made pursuant to the agency's policies, procedures and rules. Vendors should visit [www.state.wv.us/admin/purchase/privacy](http://www.state.wv.us/admin/purchase/privacy) for the Notice of Agency Confidentiality Policies.

Under penalty of law for false swearing (West Virginia Code §61-5-3), it is hereby certified that the vendor acknowledges the information in this said affidavit and is in compliance with the requirements as stated.

Vendor's Name: Arlini Construction Inc.

Authorized Signature: [Signature] Date: 10/12/08

**BID BOND**

KNOW ALL MEN BY THESE PRESENTS, That we, the undersigned, A.L.L. Construction, Inc.  
of State Route 93, PO Box 92, Mt. Storm, WV 26739, as Principal, and First National Insurance  
Company of America, Safeco Plaza, Seattle, WA 98185, a corporation organized and existing under the laws of the State of Washington with its principal office in the City of Seattle, as Surety, are held and firmly bound unto the State of West Virginia, as Obligee, in the penal sum of Five Percent (5%) of Amount (\$Bid ) for the payment of which, well and truly to be made, we jointly and severally bind ourselves, our heirs, administrators, executors, successors and assigns.

The Condition of the above obligation is such that whereas the Principal has submitted to the Purchasing Section of the Department of Administration a certain bid or proposal, attached hereto and made a part hereof, to enter into a contract in writing for Mix Shed for West Virginia Division of Highways  
Mineral County, Short Gap, West Virginia

NOW THEREFORE,

- (a) If said bid shall be rejected, or
- (b) If said bid shall be accepted and the Principal shall enter into a contract in accordance with the bid or proposal attached hereto and shall furnish any other bonds and insurance required by the bid or proposal, and shall in all other respects perform the agreement created by the acceptance of said bid, then this obligation shall be null and void, otherwise this obligation shall remain in full force and effect. It is expressly understood and agreed that the liability of the Surety for any and all claims hereunder shall, in no event, exceed the penal amount of this obligation as herein stated.

The Surety, for the value received, hereby stipulates and agrees that the obligations of said Surety and its bond shall be in no way impaired or affected by any extension of the time within which the Obligee may accept such bid, and said Surety does hereby waive notice of any such extension.

IN WITNESS WHEREOF, Principal and Surety have hereunto set their hands and seals, and such of them as are corporations have caused their corporate seals to be affixed hereunto and these presents to be signed by their proper officers, this 15th day of October, 2008.

Principal Corporate Seal

A.L.L. Construction, Inc.  
(Name of Principal)

By  (Must be President or Vice-President)  
(Title)

Surety Corporate Seal

First National Insurance Company of America  
(Name of Surety)

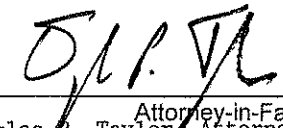
By   
Attorney-in-Fact  
Douglas P. Taylor, Attorney-in-Fact  
Licensed West Virginia Resident Agent

**IMPORTANT – Surety executing bonds must be licensed in West Virginia to transact surety insurance. Raised corporate seals must be affixed, a power of attorney must be attached.**



FIRST NATIONAL SURETY  
PO BOX 34526  
SEATTLE, WA 98124-1526

POWER  
OF ATTORNEY

FIRST NATIONAL INSURANCE COMPANY OF AMERICA  
PO BOX 34526  
SEATTLE, WA 98124-1526

No. 2034

KNOW ALL BY THESE PRESENTS:

That FIRST NATIONAL INSURANCE COMPANY OF AMERICA, a Washington corporation, does hereby appoint  
\*KIMBERLY L. MILES; JANIS K. PEACOCK; DOUGLAS P. TAYLOR; ANDREW K. TEETER; DONNA J. PRICE; PAMELA V. LANHAM; Charleston, West Virginia\*

its true and lawful attorney(s)-in-fact, with full authority to execute on behalf of the company fidelity and surety bonds or undertakings and other documents of a similar character issued by the company in the course of its business, and to bind FIRST NATIONAL INSURANCE COMPANY OF AMERICA thereby as fully as if such instruments had been duly executed by its regularly elected officers at its home office.

IN WITNESS WHEREOF, FIRST NATIONAL INSURANCE COMPANY OF AMERICA has executed and attested these presents

this 14th day of January, 2004

CHRISTINE MEAD, SECRETARY

MIKE MCGAVICK, PRESIDENT

CERTIFICATE

Extract from the By-Laws of FIRST NATIONAL INSURANCE COMPANY OF AMERICA:

"Article V, Section 13. - FIDELITY AND SURETY BONDS ... the President, any Vice President, the Secretary, and any Assistant Vice President appointed for that purpose by the officer in charge of surety operations, shall each have authority to appoint individuals as attorneys-in-fact or under other appropriate titles with authority to execute on behalf of the company fidelity and surety bonds and other documents of similar character issued by the company in the course of its business... On any instrument making or evidencing such appointment, the signatures may be affixed by facsimile. On any instrument conferring such authority or on any bond or undertaking of the company, the seal, or a facsimile thereof, may be impressed or affixed or in any other manner reproduced; provided, however, that the seal shall not be necessary to the validity of any such instrument or undertaking."

Extract from a Resolution of the Board of Directors of  
FIRST NATIONAL INSURANCE COMPANY OF AMERICA adopted July 28, 1970.

"On any certificate executed by the Secretary or an assistant secretary of the Company setting out,  
(i) The provisions of Article V, Section 13 of the By-Laws, and  
(ii) A copy of the power-of-attorney appointment, executed pursuant thereto, and  
(iii) Certifying that said power-of-attorney appointment is in full force and effect,  
the signature of the certifying officer may be by facsimile, and the seal of the Company may be a facsimile thereof."

I, Christine Mead, Secretary of FIRST NATIONAL INSURANCE COMPANY OF AMERICA, do hereby certify that the foregoing extracts of the By-Laws and of a Resolution of the Board of Directors of this corporation, and of a Power of Attorney issued pursuant thereto, are true and correct, and that both the By-Laws, the Resolution and the Power of Attorney are still in full force and effect.

IN WITNESS WHEREOF, I have hereunto set my hand and affixed the facsimile seal of said corporation

this 15th day of October, 2008



CHRISTINE MEAD, SECRETARY