



State of West Virginia  
 Department of Administration  
 Purchasing Division  
 2019 Washington Street East  
 Post Office Box 50130  
 Charleston, WV 25305-0130

# Request for Quotation

RFQ NUMBER:  
**DEP14142**

PAGE:  
**1**

ADDRESS CORRESPONDENCE TO ATTENTION OF:  
**CHUCK BOWMAN  
 304-558-2157**

VENDOR

\*709052008      304 765 5288  
**MCCOURT & SON CONSTRUCTION INC**  
**2790 CENTRALIA ROAD**  
  
**SUTTON WV 26601**

PHILIPPI

**ENVIRONMENTAL PROTECTION  
 DEPT. OF  
 OFFICE OF SPECIAL RECLAMATION  
 105 S. RAILROAD STREET  
 PHILIPPI, WV  
 26416-9998      304-457-3219**

DATE PRINTED	TERMS OF SALE	SHIP VIA	F.O.B.	FREIGHT TERMS
08/22/2007				

BID OPENING DATE: **09/25/2007**      **BID OPENING TIME 01:30PM**

LINE	QUANTITY	UOP	CAT NO	ITEM NUMBER	UNIT PRICE	AMOUNT
0001	1	JB		962-73		\$456,082.50
<p><b>RECLAMATION: RESTORATION OF WATER</b></p> <p>THE WEST VIRGINIA PURCHASING DIVISION, FOR THE AGENCY, THE WEST VIRGINIA DEPARTMENT OF ENVIRONMENTAL PROTECTION, IS SOLICITING BIDS TO AWARD A CONTRACT TO PERFORM WATER RECLAMATION ON THE MINING OPERATION OF BUFFALO COAL CO., INC., NOW UNDER REVOKED PERMIT NUMBER S-122-80, PER THE ATTACHED SPECIFICATIONS, DRAWINGS, BID REQUIREMENTS, SCOPE OF WORK, AND TERMS AND CONDITIONS.</p> <p>THE RECLAMATION SHALL BE PERFORMED UNDER THE GUIDANCE AND GENERAL SUPERVISION OF THE AGENT ASSIGNED TO THE PROJECT FOR THE STATE OF WEST VIRGINIA, DEPARTMENT OF ENVIRONMENTAL PROTECTION.</p> <p>A MANDATORY ON SITE PREBID CONFERENCE SHALL BE HELD ON 09/06/07 @ 10:00 AM. FAILURE TO ATTEND THE PREBID CONFERENCE WILL RESULT IN BID DISQUALIFICATION. FROM THOMAS TRAVEL NORTH APPRX. 3.6 MILES ON US RT 219. TURN RIGHT ONTO COUNTY RT. 9. TRAVEL APPRX. 1.2 MILES TO HAUL ROAD ON LEFT. GO STRAIGHT 1.6 MILES. PERMIT IS ON THE RIGHT.</p> <p>THE CONTRACTOR SHALL PROVIDE ALL LABOR, MATERIALS, EQUIPMENT AND OTHER NECESSARY SERVICES SO AS TO ACCOMPLISH THE ITEMS AS SPECIFIED IN THIS CONTRACT. PROJECT IS LOCATED NEAR THOMAS, WV, TUCKER COUNTY AND CONSISTS OF APPROXIMATELY 12.0 ACRES.</p> <p>ALL WORK MUST BE COMPLETED IN ACCORDANCE WITH THE PLANS AND SPECIFICATIONS PREPARED BY THE DEPARTMENT OF</p>						

SEE REVERSE SIDE FOR TERMS AND CONDITIONS

SIGNATURE <i>James M. Court</i>	TELEPHONE 304-765-5288	DATE 10/02/2007
TITLE President	FAX 55-062-4840	ADDRESS CHANGES TO BE NOTED ABOVE

WHEN RESPONDING TO RFQ, INSERT NAME AND ADDRESS IN SPACE ABOVE LABELED 'VENDOR'

**GENERAL TERMS & CONDITIONS  
REQUEST FOR QUOTATION (RFQ) AND REQUEST FOR PROPOSAL (RFP)**

1. Awards will be made in the best interest of the State of West Virginia.
2. The State may accept or reject in part, or in whole, any bid.
3. All quotations are governed by the *West Virginia Code* and the *Legislative Rules* of the Purchasing Division.
4. Prior to any award, the apparent successful vendor must be properly registered with the Purchasing Division and have paid the required \$125.00 registration fee.
5. All services performed or goods delivered under State Purchase Orders/Contracts are to be continued for the term of the Purchase Order/Contract, contingent upon funds being appropriated by the Legislature or otherwise being made available. In the event funds are not appropriated or otherwise available for these services or goods, this Purchase Order/Contract becomes void and of no effect after June 30.
6. Payment may only be made after the delivery and acceptance of goods or services.
7. Interest may be paid for late payment in accordance with the *West Virginia Code*.
8. Vendor preference will be granted upon written request in accordance with the *West Virginia Code*.
9. The State of West Virginia is exempt from federal and state taxes and will not pay or reimburse such taxes.
10. The Director of Purchasing may cancel any Purchase Order/Contract upon 30 days written notice to the seller.
11. The laws of the State of West Virginia and the *Legislative Rules* of the Purchasing Division shall govern all rights and duties under the Contract, including without limitation the validity of this Purchase Order/Contract.
12. Any reference to automatic renewal is hereby deleted. The Contract may be renewed only upon mutual written agreement of the parties.
13. **BANKRUPTCY:** In the event the vendor/contractor files for bankruptcy protection, this contract is automatically null and void, and is terminated without further order.
14. **HIPAA Business Associate Addendum** - The West Virginia State Government HIPAA Business Associate Addendum (BAA), approved by the Attorney General, and available online at the Purchasing Division's web site (<http://www.state.wv.us/admin/purchase/vrc/hipaa.htm>) is hereby made part of the agreement. Provided that, the Agency meets the definition of a Covered Entity (45 CFR §160.103) and will be disclosing Protected Health Information (45 CFR §160.103) to the vendor.

---

**INSTRUCTIONS TO BIDDERS**

1. Use the quotation forms provided by the Purchasing Division.
2. **SPECIFICATIONS:** Items offered must be in compliance with the specifications. Any deviation from the specifications must be clearly indicated by the bidder. Alternates offered by the bidder as **EQUAL** to the specifications must be clearly defined. A bidder offering an alternate should attach complete specifications and literature to the bid. The Purchasing Division may waive minor deviations to specifications.
3. Complete all sections of the quotation form.
4. Unit prices shall prevail in cases of discrepancy.
5. All quotations are considered F.O.B. destination unless alternate shipping terms are clearly identified in the quotation.
6. **BID SUBMISSION:** All quotations must be delivered by the bidder to the office listed below prior to the date and time of the bid opening. Failure of the bidder to deliver the quotations on time will result in bid disqualifications.

**SIGNED BID TO:**

Department of Administration  
Purchasing Division  
2019 Washington Street East  
Post Office Box 50130  
Charleston, WV 25305-0130

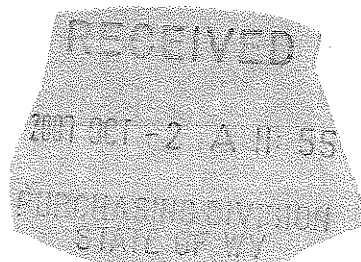



State of West Virginia  
 Department of Administration  
 Purchasing Division  
 2019 Washington Street East  
 Post Office Box 50130  
 Charleston, WV 25305-0130

# Request for Quotation

RFQ NUMBER  
 DEP14142

PAGE  
 2

ADDRESS CORRESPONDENCE TO ATTENTION OF:  
 CHUCK BOWMAN  
 304-558-2157

VENDOR

\*709052008      304 765 5288  
 MCCOURT & SON CONSTRUCTION INC  
 2790 CENTRALIA ROAD  
 SUTTON WV 26601

SHIP TO

ENVIRONMENTAL PROTECTION  
 DEPT. OF  
 OFFICE OF SPECIAL RECLAMATION  
 105 S. RAILROAD STREET  
 PHILIPPI, WV  
 26416-9998      304-457-3219

DATE PRINTED	TERMS OF SALE	SHIP VIA	F.O.B.	FREIGHT TERMS
08/22/2007				

BID OPENING DATE: 09/25/2007      BID OPENING TIME 01:30PM

LINE	QUANTITY	UOP	CAT. NO.	ITEM NUMBER	UNIT PRICE	AMOUNT
<p>ENVIRONMENTAL PROTECTION AND PURCHASE ORDER ISSUED BY THE DEPARTMENT OF ADMINISTRATION, PURCHASING DIVISION.</p> <p>EXHIBIT 5</p> <p>NOTICE TO PROCEED: THIS CONTRACT IS TO BE PERFORMED WITHIN 365 CALENDAR DAYS AFTER THE NOTICE TO PROCEED IS RECEIVED. UNLESS OTHERWISE SPECIFIED, THE FULLY EXECUTED PURCHASE ORDER WILL BE CONSIDERED NOTICE TO PROCEED.</p> <p>CANCELLATION: THE DIRECTOR OF PURCHASING RESERVES THE RIGHT TO CANCEL THIS CONTRACT IMMEDIATELY UPON WRITTEN NOTICE TO THE VENDOR IF THE MATERIALS OR WORKMANSHIP SUPPLIED ARE OF AN INFERIOR QUALITY OR DO NOT CONFORM WITH THE SPECIFICATIONS OF THE THE BID AND CONTRACT HEREIN.</p> <p>WAGE RATES: THE CONTRACTOR OR SUBCONTRACTOR SHALL PAY THE HIGHER OF THE U.S. DEPARTMENT OF LABOR MINIMUM WAGE RATES AS ESTABLISHED FOR TUCKER COUNTY, PURSUANT TO WEST VIRGINIA CODE 21-5A, ET,SEQ.</p> <p>ARBITRATION: ANY REFERENCES MADE TO ARBITRATION OR INTEREST FOR PAYMENTS DUE (EXCEPT FOR ANY INTEREST REQUIRED BY STATE LAW) CONTAINED IN THIS CONTRACT OR IN ANY AMERICAN INSTITUTE OF ARCHITECTS DOCUMENTS PERTAINING TO THIS CONTRACT ARE HEREBY DELETED.</p> <p>WORKERS' COMPENSATION: VENDOR IS REQUIRED TO PROVIDE A CERTIFICATE FROM WORKERS' COMPENSATION IF SUCCESSFUL.</p> <p>ALL OF THE ITEMS CHECKED BELOW WILL BE A REQUIREMENT OF THIS CONTRACT:</p>						

SEE REVERSE SIDE FOR TERMS AND CONDITIONS

SIGNATURE	TELEPHONE	DATE
TITLE	FEIN	ADDRESS CHANGES TO BE NOTED ABOVE

WHEN RESPONDING TO RFQ, INSERT NAME AND ADDRESS IN SPACE ABOVE LABELED 'VENDOR'



State of West Virginia  
 Department of Administration  
 Purchasing Division  
 2019 Washington Street East  
 Post Office Box 50130  
 Charleston, WV 25305-0130

# Request for Quotation

RFO NUMBER  
 DEP14142

PAGE  
 3

ADDRESS CORRESPONDENCE TO ATTENTION OF:  
 CHUCK BOWMAN  
 304-558-2157

VENDOR

\*709052008      304 765 5288  
 MCCOURT & SON CONSTRUCTION INC  
 2790 CENTRALIA ROAD  
 SUTTON WV 26601

SHIP TO

ENVIRONMENTAL PROTECTION  
 DEPT. OF  
 OFFICE OF SPECIAL RECLAMATION  
 105 S. RAILROAD STREET  
 PHILIPPI, WV  
 26416-9998      304-457-3219

DATE PRINTED	TERMS OF SALE	SHIP VIA	F.O.B.	FREIGHT TERMS
08/22/2007				

BID OPENING DATE: 09/25/2007      BID OPENING TIME 01:30PM

LINE	QUANTITY	UOP	CAT. NO.	ITEM NUMBER	UNIT PRICE	AMOUNT
<p>(XX) INSURANCE: SUCCESSFUL VENDOR SHALL FURNISH PROOF OF COMMERCIAL GENERAL LIABILITY INSURANCE PRIOR TO ISSUANCE OF CONTRACT. UNLESS OTHERWISE SPECIFIED IN THE BID DOCUMENTS, THE MINIMUM AMOUNT OF INSURANCE COVERAGE REQUIRED IS \$250,000.</p> <p>( ) BUILDERS RISK INSURANCE: SUCCESSFUL VENDOR SHALL FURNISH PROOF OF BUILDERS RISK - ALL RISK INSURANCE IN AN AMOUNT EQUAL TO 100% OF THE AMOUNT OF THE CONTRACT.</p> <p>(XX) BONDS: FIVE PERCENT (5%) OF THE TOTAL AMOUNT OF THE BID PAYABLE TO THE STATE OF WEST VIRGINIA, SHALL BE SUBMITTED WITH EACH BID AS A BID BOND. THE SUCCESSFUL BIDDER SHALL ALSO FURNISH A PERFORMANCE BOND AND LABOR/MATERIAL BOND FOR 100% OF THE AMOUNT OF THE CONTRACT. BONDS MAY BE PROVIDED IN THE FORM OF A CERTIFIED CHECK, IRREVOCABLE LETTER OF CREDIT, OR BOND FURNISHED BY A SOLVENT SURETY COMPANY AUTHORIZED TO DO BUSINESS IN THE STATE OF WEST VIRGINIA. A LETTER OF CREDIT SUBMITTED IN LIEU OF A PERFORMANCE AND LABOR &amp; MATERIAL BOND WILL ONLY BE ALLOWED FOR PROJECTS UNDER \$100,000. PERSONAL OR BUSINESS CHECKS ARE NOT ACCEPTABLE IN LIEU OF THE 5% BID BOND, PERFORMANCE BOND, OR LABOR/MATERIAL BOND.</p> <p>( ) MAINTENANCE BOND: A TWO (2) YEAR MAINTENANCE BOND COVERING THE ROOFING SYSTEM WILL BE A REQUIREMENT OF THE SUCCESSFUL VENDOR.</p> <p>REV. 11/00</p> <p>CONTRACTORS LICENSE</p> <p>WEST VIRGINIA STATE CODE 21-11-2 REQUIRES THAT ALL PERSONS DESIRING TO PERFORM CONTRACTING WORK IN THIS STATE MUST BE LICENSED. THE WEST VIRGINIA CONTRACTORS</p>						

SEE REVERSE SIDE FOR TERMS AND CONDITIONS

SIGNATURE	TELEPHONE	DATE
TITLE	FEIN	ADDRESS CHANGES TO BE NOTED ABOVE

WHEN RESPONDING TO RFQ, INSERT NAME AND ADDRESS IN SPACE ABOVE LABELED 'VENDOR'



State of West Virginia  
 Department of Administration  
 Purchasing Division  
 2019 Washington Street East  
 Post Office Box 50130  
 Charleston, WV 25305-0130

# Request for Quotation

RFQ NUMBER  
 DEP14142

PAGE  
 4

ADDRESS CORRESPONDENCE TO ATTENTION OF:  
 CHUCK BOWMAN  
 304-558-2157

VENDOR

\*709052008      304 765 5288  
 MCCOURT & SON CONSTRUCTION INC  
 2790 CENTRALIA ROAD  
  
 SUTTON WV 26601

SHIP TO

ENVIRONMENTAL PROTECTION  
 DEPT. OF  
 OFFICE OF SPECIAL RECLAMATION  
 105 S. RAILROAD STREET  
 PHILIPPI, WV  
 26416-9998      304-457-3219

DATE PRINTED	TERMS OF SALE	SHIP VIA	F.O.B.	FREIGHT TERMS
08/22/2007				

BID OPENING DATE: **09/25/2007**      BID OPENING TIME **01:30PM**

LINE	QUANTITY	UOP	CAT NO.	ITEM NUMBER	UNIT PRICE	AMOUNT
<p>LICENSING BOARD IS EMPOWERED TO ISSUE THE CONTRACTORS LICENSE. APPLICATIONS FOR A CONTRACTORS LICENSE MAY BE MADE BY CONTACTING THE WEST VIRGINIA DIVISION OF LABOR CAPITOL COMPLEX, BUILDING 3, ROOM 319, CHARLESTON, WV 25305. TELEPHONE: (304) 558-7890.</p> <p>WEST VIRGINIA STATE CODE 21-11-11 REQUIRES ANY PROSPECTIVE BIDDER TO INCLUDE THE CONTRACTORS LICENSE NUMBER ON THEIR BID.</p> <p>BIDDER TO COMPLETE:</p> <p>CONTRACTORS NAME - <u>McCourt &amp; Son Construction, Inc.</u></p> <p>CONTRACTORS LICENSE NO. - <u>WV.001913</u></p> <p>THE SUCCESSFUL BIDDER WILL REQUIRED TO FURNISH A COPY OF THEIR CONTRACTORS LICENSE PRIOR TO ISSUANCE OF A PURCHASE ORDER/CONTRACT.</p> <p style="text-align: center;">APPLICABLE LAW</p> <p>THE WEST VIRGINIA STATE CODE, PURCHASING DIVISION RULE AND REGULATIONS, AND THE INFORMATION PROVIDED IN THE "REQUEST FOR QUOTATION" ISSUED BY THE PURCHASING DIVISION IS THE SOLE AUTHORITY GOVERNING THIS PROCUREMENT.</p> <p>ANY INFORMATION PROVIDED IN SPECIFICATION MANUALS, OR ANY OTHER SOURCE, VERBAL OR WRITTEN, WHICH CONTRADICTS OR ALTERS THE INFORMATION PROVIDED FROM THE SOURCES AS DESCRIBED IN THE ABOVE PARAGRAPH IS VOID AND OF NO EFFECT.</p> <p>BANKRUPTCY: IN THE EVENT THE VENDOR/CONTRACTOR FILES FOR BANKRUPTCY PROTECTION, THIS CONTRACT IS AUTOMATI-</p>						

SEE REVERSE SIDE FOR TERMS AND CONDITIONS

SIGNATURE	TELEPHONE	DATE
TITLE	FEIN	ADDRESS CHANGES TO BE NOTED ABOVE

WHEN RESPONDING TO RFQ, INSERT NAME AND ADDRESS IN SPACE ABOVE LABELED 'VENDOR'



State of West Virginia  
 Department of Administration  
 Purchasing Division  
 2019 Washington Street East  
 Post Office Box 50130  
 Charleston, WV 25305-0130

# Request for Quotation

RFQ NUMBER  
 DEP14142

PAGE  
 5

ADDRESS CORRESPONDENCE TO ATTENTION OF:  
 CHUCK BOWMAN  
 304-558-2157

VENDOR

\*709052008      304 765 5288  
 MCCOURT & SON CONSTRUCTION INC  
 2790 CENTRALIA ROAD  
  
 SUTTON WV 26601

SHIP TO

ENVIRONMENTAL PROTECTION  
 DEPT. OF  
 OFFICE OF SPECIAL RECLAMATION  
 105 S. RAILROAD STREET  
 PHILIPPI, WV  
 26416-9998      304-457-3219

DATE PRINTED	TERMS OF SALE	SHIP VIA	F.O.B.	FREIGHT TERMS
08/22/2007				

BID OPENING DATE: **09/25/2007**      BID OPENING TIME **01:30PM**

LINE	QUANTITY	UOP	CAT NO	ITEM NUMBER	UNIT PRICE	AMOUNT
<p>CALLY NULL AND VOID, AND IS TERMINATED WITHOUT FURTHER ORDER.</p> <p>EXHIBIT 7</p> <p>DOMESTIC ALUMINUM, GLASS &amp; STEEL IN PUBLIC WORKS PROJECTS</p> <p>IN ACCORDANCE WITH WEST VIRGINIA CODE 5-19-1 ET., SEQ., EVERY CONTRACT FOR CONSTRUCTION, RECONSTRUCTION, ALTERATION, REPAIR, IMPROVEMENT OR MAINTENANCE OF PUBLIC WORKS, WHERE THE COST IS MORE THAN \$50,000 AND, IN THE CASE OF STEEL ONLY, WHERE THE COST OF STEEL IS MORE THAN \$50,000 OR WHERE MORE THAN 10,000 POUNDS OF STEEL ARE REQUIRED, THE STATE WILL ACCEPT ONLY ALUMINUM GLASS, OR STEEL PRODUCTS PRODUCED IN THE UNITED STATES. IN ADDITION, ITEMS OF MACHINERY OR EQUIPMENT PURCHASED FOR USE AT THE SITE OF PUBLIC WORKS SHALL BE MADE OF DOMESTIC ALUMINUM, GLASS OR STEEL, UNLESS THE COST OF THE PRODUCT IS LESS THAN \$50,000 OR LESS THAN 10,000 POUNDS OF STEEL ARE USED IN PUBLIC WORKS PROJECTS.</p> <p>FOREIGN MADE ALUMINUM, GLASS OR STEEL PRODUCTS MAY BE ACCEPTED ONLY IF THE COST OF DOMESTIC PRODUCTS IS FOUND TO BE UNREASONABLE. SUCH COST IS UNREASONABLE IF IT IS 20% OR MORE HIGHER THAN THE BID PRICE FOR FOREIGN MADE PRODUCTS. IF THE DOMESTIC ALUMINUM, GLASS OR STEEL PRODUCTS TO BE SUPPLIED OR PRODUCED IN A "SUBSTANTIAL LABOR SURPLUS AREA", AS DEFINED BY THE UNITED STATES DEPARTMENT OF LABOR, FOREIGN PRODUCTS MAY BE SUPPLIED ONLY IF DOMESTIC PRODUCTS ARE 30% OR MORE HIGHER IN PRICE THAN THE FOREIGN MADE PRODUCTS.</p> <p>IF, PRIOR TO THE AWARD OF A CONTRACT UNDER THE ABOVE PROVISIONS, THE SPENDING OFFICER OF THE SPENDING UNIT DETERMINES THAT THERE EXISTS A BID FOR LIKE FOREIGN</p>						

SEE REVERSE SIDE FOR TERMS AND CONDITIONS

SIGNATURE	TELEPHONE	DATE
TITLE	FEIN	ADDRESS CHANGES TO BE NOTED ABOVE

WHEN RESPONDING TO RFQ, INSERT NAME AND ADDRESS IN SPACE ABOVE LABELED 'VENDOR'



State of West Virginia  
 Department of Administration  
 Purchasing Division  
 2019 Washington Street East  
 Post Office Box 50130  
 Charleston, WV 25305-0130

# Request for Quotation

RFQ NUMBER  
 DEP14142

PAGE  
 6

ADDRESS CORRESPONDENCE TO ATTENTION OF:  
 CHUCK BOWMAN  
 304-558-2157

VENDOR

\*709052008      304 765 5288  
 MCCOURT & SON CONSTRUCTION INC  
 2790 CENTRALIA ROAD  
  
 SUTTON WV 26601

SHIP TO

ENVIRONMENTAL PROTECTION  
 DEPT. OF  
 OFFICE OF SPECIAL RECLAMATION  
 105 S. RAILROAD STREET  
 PHILIPPI, WV  
 26416-9998      304-457-3219

DATE PRINTED 08/22/2007	TERMS OF SALE	SHIP VIA	F.O.B.	FREIGHT TERMS
BID OPENING DATE: 09/25/2007		BID OPENING TIME 01:30PM		

LINE	QUANTITY	UOP	CAT. NO.	ITEM NUMBER	UNIT PRICE	AMOUNT
<p>ALUMINUM, GLASS OR STEEL THAT IS REASONABLE AND LOWER THAN THE LOWEST BID FOR DOMESTIC PRODUCTS, THE SPENDING OFFICE MAY REQUEST, IN WRITING, A REEVALUATION AND REDUCTION IN THE LOWEST BID FOR SUCH DOMESTIC PRODUCTS. ALL VENDORS MUST INDICATE IN THEIR BID IF THEY ARE SUPPLYING FOREIGN ALUMINUM, GLASS OR STEEL.</p> <p>REV. 3/88</p> <p>EXHIBIT 9</p> <p>NOTICE FOR ISSUANCE &amp; ACKNOWLEDGEMENT OF CONSTRUCTION PROJECT ADDENDA</p> <p>THE ARCHITECT/ENGINEER AND/OR AGENCY SHALL BE REQUIRED TO ABIDE BY THE FOLLOWING SCHEDULE IN ISSUING CONSTRUCTION PROJECT ADDENDA FOR STATE AGENCIES:</p> <p>(1) THE ARCHITECT/ENGINEER SHALL PREPARE THE ADDENDUM AND A LIST OF ALL PARTIES THAT HAVE PROCURED DRAWINGS AND SPECIFICATIONS FOR THE PROJECT. THE ADDENDUM AND LIST SHALL BE FORWARDED TO THE BUYER IN THE STATE PURCHASING DIVISION. THE ARCHITECT/ENGINEER SHALL ALSO SEND A COPY OF THE ADDENDUM TO THE STATE AGENCY FOR WHICH THE CONTRACT IS ISSUED.</p> <p>(2) THE BUYER SHALL SEND THE ADDENDUM TO ALL INTERESTED PARTIES AND, IF NECESSARY, EXTEND THE BID OPENING DATE. ANY ADDENDUM SHOULD BE RECEIVED BY THE BUYER WITHIN FOURTEEN (14) DAYS PRIOR TO THE BID OPENING DATE.</p> <p>(3) ALL ADDENDA SHOULD BE FORMALLY ACKNOWLEDGED BY ALL BIDDERS AND SUBMITTED TO THE STATE PURCHASING DIVISION AND THE STATE AUDITOR'S OFFICE. THE SAME RULES AND</p>						

SEE REVERSE SIDE FOR TERMS AND CONDITIONS

SIGNATURE	TELEPHONE	DATE
TITLE	FEIN	ADDRESS CHANGES TO BE NOTED ABOVE

WHEN RESPONDING TO RFQ, INSERT NAME AND ADDRESS IN SPACE ABOVE LABELED 'VENDOR'



State of West Virginia  
 Department of Administration  
 Purchasing Division  
 2019 Washington Street East  
 Post Office Box 50130  
 Charleston, WV 25305-0130

# Request for Quotation

RFQ NUMBER  
 DEP14142

PAGE  
 7

ADDRESS CORRESPONDENCE TO ATTENTION OF:  
 CHUCK BOWMAN  
 304-558-2157

**VENDOR**  
 \*709052008      304 765 5288  
 MCCOURT & SON CONSTRUCTION INC  
 2790 CENTRALIA ROAD  
  
 SUTTON WV 26601

**SHIP TO**  
 ENVIRONMENTAL PROTECTION  
 DEPT. OF  
 OFFICE OF SPECIAL RECLAMATION  
 105 S. RAILROAD STREET  
 PHILIPPI, WV  
 26416-9998      304-457-3219

DATE PRINTED	TERMS OF SALE	SHIP VIA	F.O.B.	FREIGHT TERMS
08/22/2007				

BID OPENING DATE: **09/25/2007**      BID OPENING TIME **01:30PM**

LINE	QUANTITY	UOP	CAT. NO.	ITEM NUMBER	UNIT PRICE	AMOUNT
<p>REGULATIONS THAT APPLY TO THE ORIGINAL BIDDING DOCUMENT SHALL ALSO APPLY TO AN ADDENDUM DOCUMENT. THE ONLY EXCEPTION MAY BE FOR AN ADDENDUM THAT IS ISSUED FOR THE SOLE PURPOSE OF CHANGING A BID OPENING TIME AND/OR DATE.</p> <p>REV. 11/96</p> <p>EXHIBIT 10</p> <p style="text-align: center;">REQUISITION NO.: DEP14142</p> <p>ADDENDUM ACKNOWLEDGEMENT</p> <p>I HEREBY ACKNOWLEDGE RECEIPT OF THE FOLLOWING CHECKED ADDENDUM(S) AND HAVE MADE THE NECESSARY REVISIONS TO MY PROPOSAL, PLANS AND/OR SPECIFICATION, ETC.</p> <p>ADDENDUM NO.'S:</p> <p>NO. 1 <del>XX</del>.....</p> <p>NO. 2 .....</p> <p>NO. 3 .....</p> <p>NO. 4 .....</p> <p>NO. 5 .....</p> <p>I UNDERSTAND THAT FAILURE TO CONFIRM THE RECEIPT OF THE ADDENDUM(S) MAY BE CAUSE FOR REJECTION OF BIDS.</p> <p style="text-align: right;"><i>[Signature]</i></p>						

SEE REVERSE SIDE FOR TERMS AND CONDITIONS

SIGNATURE <i>[Signature]</i>	TELEPHONE 304-765-5288	DATE 10/02/2007
TITLE President	FEIN 55-062-4840	ADDRESS CHANGES TO BE NOTED ABOVE

WHEN RESPONDING TO RFQ, INSERT NAME AND ADDRESS IN SPACE ABOVE LABELED 'VENDOR'





State of West Virginia  
 Department of Administration  
 Purchasing Division  
 2019 Washington Street East  
 Post Office Box 50130  
 Charleston, WV 25305-0130

# Request for Quotation

RFQ NUMBER  
 DEP14142

PAGE  
 8

ADDRESS CORRESPONDENCE TO ATTENTION OF:  
 CHUCK BOWMAN  
 304-558-2157

**VENDOR**  
 \*709052008 304 765 5288  
 MCCOURT & SON CONSTRUCTION INC  
 2790 CENTRALIA ROAD  
 SUTTON WV 26601

**SHIP TO**  
 ENVIRONMENTAL PROTECTION  
 DEPT. OF  
 OFFICE OF SPECIAL RECLAMATION  
 105 S. RAILROAD STREET  
 PHILIPPI, WV  
 26416-9998 304-457-3219

DATE PRINTED	TERMS OF SALE	SHIP VIA	F.O.B.	FREIGHT TERMS
08/22/2007				

BID OPENING DATE: **09/25/2007** BID OPENING TIME **01:30PM**

LINE	QUANTITY	UOP	CAT. NO.	ITEM NUMBER	UNIT PRICE	AMOUNT
<p><b>SIGNATURE</b>            ..McCourt &amp; Son Construction, Inc.  <b>COMPANY</b>            09/25/2007            .....  <b>DATE</b></p>						
<p>REV. 11/96</p> <p style="text-align: center;"><b>NOTICE</b></p> <p><b>A SIGNED BID MUST BE SUBMITTED TO:</b></p> <p style="text-align: center;">DEPARTMENT OF ADMINISTRATION            PURCHASING DIVISION            BUILDING 15            2019 WASHINGTON STREET, EAST            CHARLESTON, WV 25305-0130</p> <p><b>THE BID SHOULD CONTAIN THIS INFORMATION ON THE FACE OF THE ENVELOPE OR THE BID MAY NOT BE CONSIDERED:</b></p> <p><b>SEALED BID</b></p> <p><b>BUYER:</b> CB-23  <b>RFQ. NO.:</b> DEP14142  <b>BID OPENING DATE:</b> 09/25/2007  <b>BID OPENING TIME:</b> 1:30 PM</p>						

SEE REVERSE SIDE FOR TERMS AND CONDITIONS

SIGNATURE	TELEPHONE	DATE
TITLE	FEIN	ADDRESS CHANGES TO BE NOTED ABOVE

WHEN RESPONDING TO RFQ, INSERT NAME AND ADDRESS IN SPACE ABOVE LABELED 'VENDOR'



**GENERAL TERMS & CONDITIONS  
REQUEST FOR QUOTATION (RFQ) AND REQUEST FOR PROPOSAL (RFP)**

1. Awards will be made in the best interest of the State of West Virginia.
2. The State may accept or reject in part, or in whole, any bid.
3. All quotations are governed by the *West Virginia Code* and the *Legislative Rules* of the Purchasing Division.
4. Prior to any award, the apparent successful vendor must be properly registered with the Purchasing Division and have paid the required \$125.00 registration fee.
5. All services performed or goods delivered under State Purchase Orders/Contracts are to be continued for the term of the Purchase Order/Contract, contingent upon funds being appropriated by the Legislature or otherwise being made available. In the event funds are not appropriated or otherwise available for these services or goods, this Purchase Order/Contract becomes void and of no effect after June 30.
6. Payment may only be made after the delivery and acceptance of goods or services.
7. Interest may be paid for late payment in accordance with the *West Virginia Code*.
8. Vendor preference will be granted upon written request in accordance with the *West Virginia Code*.
9. The State of West Virginia is exempt from federal and state taxes and will not pay or reimburse such taxes.
10. The Director of Purchasing may cancel any Purchase Order/Contract upon 30 days written notice to the seller.
11. The laws of the State of West Virginia and the *Legislative Rules* of the Purchasing Division shall govern all rights and duties under the Contract, including without limitation the validity of this Purchase Order/Contract.
12. Any reference to automatic renewal is hereby deleted. The Contract may be renewed only upon mutual written agreement of the parties.
13. **BANKRUPTCY:** In the event the vendor/contractor files for bankruptcy protection, this contract is automatically null and void, and is terminated without further order.
14. **HIPAA Business Associate Addendum** - The West Virginia State Government HIPAA Business Associate Addendum (BAA), approved by the Attorney General, and available online at the Purchasing Division's web site (<http://www.state.wv.us/admin/purchase/vrc/hipaa.htm>) is hereby made part of the agreement. Provided that, the Agency meets the definition of a Covered Entity (45 CFR §160.103) and will be disclosing Protected Health Information (45 CFR §160.103) to the vendor.

---

**INSTRUCTIONS TO BIDDERS**

1. Use the quotation forms provided by the Purchasing Division.
2. **SPECIFICATIONS:** Items offered must be in compliance with the specifications. Any deviation from the specifications must be clearly indicated by the bidder. Alternates offered by the bidder as **EQUAL** to the specifications must be clearly defined. A bidder offering an alternate should attach complete specifications and literature to the bid. The Purchasing Division may waive minor deviations to specifications.
3. Complete all sections of the quotation form.
4. Unit prices shall prevail in cases of discrepancy.
5. All quotations are considered F.O.B. destination unless alternate shipping terms are clearly identified in the quotation.
6. **BID SUBMISSION:** All quotations must be delivered by the bidder to the office listed below prior to the date and time of the bid opening. Failure of the bidder to deliver the quotations on time will result in bid disqualifications.

**SIGNED BID TO:**

Department of Administration  
Purchasing Division  
2019 Washington Street East  
Post Office Box 50130  
Charleston, WV 25305-0130

**Buffalo Coal Co. Inc.**  
**Permit No. S-122-80**

**LOCATION MAP**  
**MARYLAND**

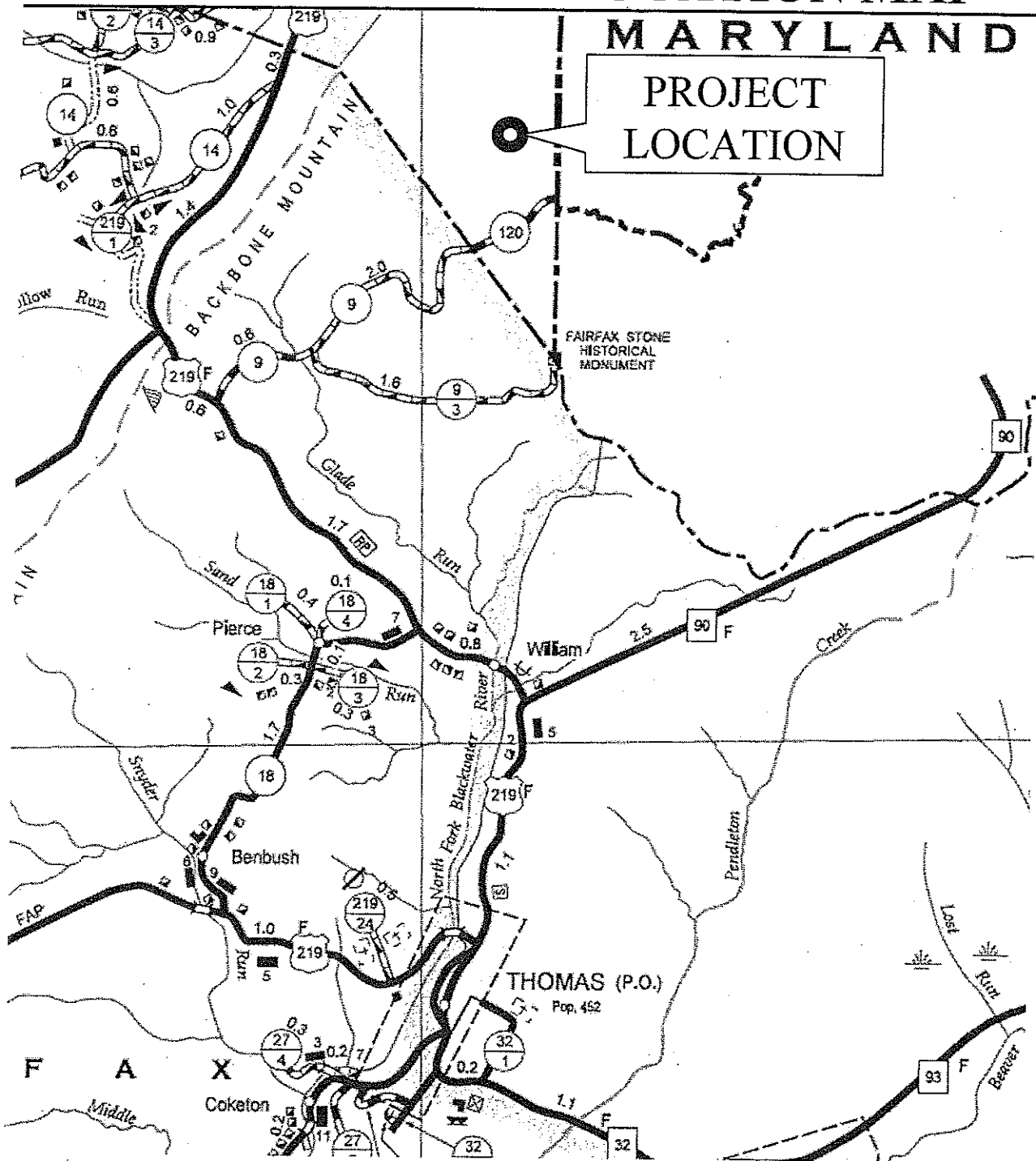

From Thomas travel North approximately 3.6 miles on US Route 219. Turn right onto County Route 9. Travel approximately 1.2 miles to haul road on left. Go straight for 1.6 miles. Permit is on the right.

BUYER CB-23	PAGE 011	REQ. OR PO NO. DEP 14142
SPENDING UNIT WEST VIRGINIA DEPARTMENT OF ENVIRONMENTAL PROTECTION/SPECIAL RECLAMATION		

WV-36a STATE OF WEST VIRGINIA  
 Rev. 1/29/02 PURCHASING CONTINUATION SHEET  
 VENDOR:

**SCOPE OF WORK**

The successful bidder shall provide appropriate equipment, materials, labor and any technical services needed for the successful reclamation of Buffalo Coal Company Inc., Permit S-122-80, and any disturbance associated with such operation. The General Performance Standards (GPS) shall apply to all items in Scope of Work.

Work necessary on this site will include the following items, but is not limited to these:

1. Upon mobilization to the site, which will be directed in a written Notice to Proceed, the access roads shall be developed in accordance with bid item # 5.0 and 6.0. If, fuel and lubricants are to be stored on site, bid item #2.0 shall be in place before fuel is delivered. Project sign is to be obtained and installed.
2. Storm water management in the form as described in bid item #9.0 shall be installed (described locations).
3. Regrading and topsoiling is required for 12 acres. Revegetation is required for 12 acres. Reclamation is to be according to the attached specifications, plans, and clarifying discussions at the Pre-Bid Conference.
4. Install dosing unit and silo.
5. Construct riprap ditches or open limestone channels.
6. Repair existing ditches.
7. Remove structures and debris from site.
8. Construct seep collection drains.
9. Construct and repair ponds.
10. Regrade disturbed area.
11. Install culverts.
12. Construct and improve roads.
13. Revegetate with seed, lime, fertilizer, and mulch.

I, David B. McCoy, the undersigned, hereby certify <sup>1</sup> that this Reclamation Plan is correct and shows to the best of my knowledge and belief all the information required by the surface mining laws of the State of West Virginia. The source of information was the approved mining and reclamation plan contained in the forfeited surface mine permit, existing site conditions and information contained in the WV DEP, Inspection and Enforcement files.

\_\_\_\_\_  
 Registered Professional Engineer WV No. 14375

\_\_\_\_\_  
 Date

<sup>1</sup> The term "**certify**" as used herein is defined as follows: An engineer's certification of conditions is a declaration of professional judgment. It does not constitute a warranty or guarantee, either expressed or implied.

BUYER CB-23	PAGE 2	REQ. OR PO NO. DEP 14142
SPENDING UNIT WEST VIRGINIA DEPARTMENT OF ENVIRONMENTAL PROTECTION/SPECIAL RECLAMATION		

WV-36a STATE OF WEST VIRGINIA  
 Rev. 1/29/02 PURCHASING CONTINUATION SHEET  
 VENDOR:

ITEM NO.	QUANTITY	DESCRIPTION	UNIT PRICE	AMOUNT
<b>BID SCHEDULE</b>				
<b>PERMIT NAME: <u>BUFFALO COAL COMPANY, INC.</u></b>				
<b>PERMIT NUMBER: <u>S-122-80</u></b>				
1.0	LUMP SUM	<b><u>MOBILIZATION/DEMobilIZATION/PROJECT SIGN</u></b> (5% Total Bid Maximum for this permit)	LUMP SUM	<u>\$18,500.00</u>
2.0	LUMP SUM	<b><u>SPILL CONTAINMENT AREA (S.C.A.)</u></b> (\$1,000.00 Maximum Bid for this permit)	LUMP SUM	<u>\$1,000.00</u>
3.0	<u>6</u> AC	<b><u>ROAD FILL REMOVAL</u></b>	<u>\$1,500.00</u> PER ACRE	<u>\$9,000.00</u>
4.0	LUMP SUM	<b><u>CLEAR AND GRUB</u></b>	LUMP SUM	<u>\$5,700.00</u>
5.0	LUMP SUM	<b><u>MAINTAIN HAULROAD/ACCESS ROAD</u></b>	LUMP SUM	<u>\$1,000.00</u>
6.0	<u>1300</u> LF	<b><u>NEW ROAD CONSTRUCTION</u></b>	<u>\$ 15.50</u> PER LF	<u>\$ 20,150.00</u>
7.0	<u>1500</u> TON	<b><u>INCIDENTAL LIMESTONE FOR ROADS</u></b>	<u>\$ 15.00</u> PER TON	<u>\$22,500.00</u>
8.0	<u>12</u> AC	<b><u>REGRAIDING AND TOPSOILING</u></b>	<u>\$1,400.00</u> PER ACRE	<u>\$ 16,800.00</u>
9.0	<u>1000</u> LF	<b><u>HAYBALE DIKE</u></b> (Max. Bid \$5.00 Per LF)	<u>\$ 2.25</u> PER LF	<u>\$ 2,250.00</u>
10.0		<b><u>REVEGETATION</u></b>		
10.1	<u>12</u> AC	<b><u>AGRICULTURAL LIME</u></b>	<u>\$125.00</u> PER ACRE	<u>\$ 1,500.00</u>
10.2	<u>12</u> AC	<b><u>FERTILIZER</u></b>	<u>\$ 210.00</u> PER ACRE	<u>\$2,520.00</u>

WV-36a                      STATE OF WEST VIRGINIA  
 Rev. 1/29/02            PURCHASING CONTINUATION SHEET  
 VENDOR:

10.3	<u>12</u> AC	<u>MULCH</u>	\$ <u>650.00</u> PER ACRE	\$ <u>7,800.00</u>
10.4	<u>12</u> AC	<u>VEGETATIVE SPECIES</u>	\$ <u>560.00</u> PER ACRE	\$ <u>6,720.00</u>
11.0	LUMP SUM	<u>CONSTRUCTED SLUDGE DISPOSAL CELL</u>	LUMP SUM	\$ <u>5,500.00</u>
12.0	<u>200</u> LF	<u>TRAPEZOIDAL RIPRAP CHANNEL</u>	\$ <u>40.50</u> PER LF	\$ <u>8,100.00</u>
13.0	LUMP SUM	<u>DRIVE WATER COLLECTION POND</u>	LUMP SUM	\$ <u>5,500.00</u>
14.0	LUMP SUM	<u>RISER INTAKE UNIT</u>	LUMP SUM	\$ <u>4,300.00</u>
15.0	LUMP SUM	<u>POND CLEANING AND MODIFICATION</u>	LUMP SUM	\$ <u>14,000.00</u>
16.0	<u>160</u> LF	<u>BAFFLE CURTAIN</u>	\$ <u>14.50</u> PER LF	\$ <u>2,320.00</u>
17.0	<u>80</u> LF	<u>TRAPEZOIDAL EXIT SPILLWAY CHANNEL</u>	\$ <u>55.00</u> PER LF	\$ <u>4,400.00</u>
18.0	<u>2400</u> LF	<u>FRESHWATER DIVERSION DITCH</u>	\$ <u>24.00</u> PER LF	\$ <u>57,600.00</u>
19.0	<u>270</u> LF	<u>RIPRAP V-DITCH</u>	\$ <u>30.75</u> PER LF	\$ <u>8,302.50</u>
20.0	<u>930</u> LF	<u>GROUTED RIPRAP DITCH</u>	\$ <u>75.00</u> PER LF	\$ <u>69,750.00</u>

BUYER CB-23	PAGE 14	REQ. OR PO NO. DEP 14142
SPENDING UNIT WEST VIRGINIA DEPARTMENT OF ENVIRONMENTAL PROTECTION/SPECIAL RECLAMATION		

WV-36a STATE OF WEST VIRGINIA  
 Rev. 1/29/02 PURCHASING CONTINUATION SHEET  
 VENDOR:

21.0	<u>90</u> LF	<u>SEEP COLLECTOR</u>	\$ <u>52.00</u> PER LF	\$ <u>4,680.00</u>
22.0	<u>160</u> LF	<u>4 INCH HDPE DRIVE LINE PIPE</u>	\$ <u>8.00</u> PER LF	\$ <u>1,280.00</u>
23.0	LUMP SUM	<u>WATER CONNECTION AT DISPENSING UNIT</u>	LUMP SUM	\$ <u>1,800.00</u>
24.0	<u>700</u> LF	<u>6 INCH HDPE SLUDGE PIPE</u>	\$ <u>9.50</u> PER LF	\$ <u>6,650.00</u>
25.0	<u>80</u> LF	<u>12 INCH HDPE PIPE</u>	\$ <u>22.00</u> PER LF	\$ <u>1,760.00</u>
26.0	<u>100</u> LF	<u>30 INCH HDPE CULVERT PIPE</u>	\$ <u>38.10</u> PER LF	\$ <u>3,810.00</u>
27.0	<u>40</u> LF	<u>36 INCH HDPE CULVERT PIPE</u>	\$ <u>50.00</u> PER LF	\$ <u>2,000.00</u>
28.0	<u>80</u> LF	<u>48 INCH HDPE CULVERT PIPE</u>	\$ <u>86.75</u> PER LF	\$ <u>6,940.00</u>
29.0	<u>4</u> EA	<u>PUMP ADAPTOR CONNECTION</u>	\$ <u>300.00</u> PER EA	\$ <u>1,200.00</u>
30.0	<u>1</u> EA	<u>TEES (6 INCH HDPE 90°)</u>	\$ <u>600.00</u> PER EA	\$ <u>600.00</u>
31.0	<u>1</u> EA	<u>WYES (6" HDPE LATERALS 45°)</u>	\$ <u>600.00</u> PER EA	\$ <u>600.00</u>
32.0	<u>2</u> EA	<u>FLANGE (6" HDPE)</u>	\$ <u>250.00</u> PER EA	\$ <u>500.00</u>
33.0	<u>1</u> EA	<u>6 INCH GATE VALVE</u>	\$ <u>750.00</u> PER EA	\$ <u>750.00</u>
34.0	LUMP SUM	<u>FOUNDATION</u>	LUMP SUM	\$ <u>7,500.00</u>



BUYER CB-23	PAGE <u>015</u>	REQ. OR PO NO. DEP 14142
SPENDING UNIT WEST VIRGINIA DEPARTMENT OF ENVIRONMENTAL PROTECTION/SPECIAL RECLAMATION		

WV-36a STATE OF WEST VIRGINIA  
 Rev. 1/29/02 PURCHASING CONTINUATION SHEET  
 VENDOR:

35.0	<u>10</u> LF (DEPTH)	<u>SUB FOUNDATION AND PREPARATION</u>	\$ <u>150.00</u> PER LF	\$ <u>1,500.00</u>
36.0	LUMP SUM	<u>CRANE</u>	LUMP SUM	\$ <u>3,000.00</u>
37.0	LUMP SUM	<u>DOSING UNIT AND SILO</u>	LUMP SUM	\$ <u>109,000.00</u>
38.0	LUMP SUM	<u>STRUCTURE AND DEBRIS REMOVAL</u>	LUMP SUM	\$ <u>900.00</u>
39.0	<u>800</u> LF	<u>EXISTING ROAD DITCH REPAIR</u>	\$ <u>8.00</u> PER LF	\$ <u>6,400.00</u>
TOTAL PERMIT <u>S-122-80</u>				\$ <u>456,082.50</u>

BUYER CB-23	PAGE 016	REQ. OR PO NO. DEP 14142
SPENDING UNIT WEST VIRGINIA DEPARTMENT OF ENVIRONMENTAL PROTECTION/SPECIAL RECLAMATION		

WV-36a STATE OF WEST VIRGINIA  
 Rev. 1/29/02 PURCHASING CONTINUATION SHEET  
 VENDOR:

**BID ITEM TECHNICAL SPECIFICATIONS**

**1.0 MOBILIZATION/DEMobilIZATION/PROJECT SIGN**

**PROJECT SIGN**

A project sign shall be obtained or manufactured and installed as indicated on the attached specifications and details. Payment for this sign shall be incidental to the mobilization item. No separate payment will be made.

**MOBILIZATION**

This work shall consist of the performance of construction preparatory operations, including the movement of personnel, equipment and other facilities to the project site necessary to begin work on a substantial phase of the contract.

**DEMobilIZATION**

Prior to demobilization, an inspection shall be conducted by the Department of Environmental Protection and the contractor to insure compliance with contract performance. Once compliance is ascertained, demobilization activities can be initiated and completed. Demobilization shall be totally completed before the invoice for payment shall be processed.

**PAYMENT**

The lump sum bid for this item shall not exceed 5% of the total bid for this permit. Payment shall be made in two 50% amounts, one upon completion of the mobilization and project sign items and the second payment at the completion of demobilization. No deduction shall be made nor shall any increase be made in the lump sum item amount, regardless of decreases or increases in the final total contract amount or any other reason.

**2.0 SPILL CONTAINMENT AREA (S.C.A.)**

Spill containment measures shall be used for fuel and lubricant storage areas. All containers, barrels, buckets, cans, etc., are to be legally disposed of off site. Used lubricants are to be disposed of according to state law to minimize pollution to the local surface and ground water supplies. Spills are the responsibility of the contractor and need immediate clean up and maintained at no expense to the State. This S.C.A. shall be constructed in accordance with the typical drawing specification. (See Attachment) Alternate containment measures will be considered for approval by the Program Manager if acceptable results can be shown. Fuel tanks manufactured with secondary containment are desirable. Minimum secondary containment is 110 percent. (Bid limited to \$1,000.00 maximum)

**3.0 ROAD FILL REMOVAL**

A road fill connecting the main access road to the spoil disposal area shall be partially removed and an existing 36 inch diameter culvert draining the area behind the fill shall be sealed with cement grout. Material excavated from the fill will be used to raise the stream channel and the area upstream of the fill to a non-impounding level to be determined by the WV DEP on site inspector. A new 48 inch diameter culvert (Bid Item 28.0) will replace the 36 inch diameter culvert once final grade is achieved. The safety berm on the downhill side of the road shall be replaced, after the road has been lowered and re-graded.

The current road shall be lowered a minimum of 10 feet at a point in the turn, at the building parking area. The level area in front of and surrounding the building shall be lowered and re-graded to meet the lowered road grade. Any additional material required to raise the upstream area to a non-impounding level will be obtained from the spoil disposal area as indicated on the site plan.

**4.0 CLEAR AND GRUB**

All vegetative cover (trees, shrubs, bushes etc.) within the entire work area shall be removed to bare ground. It is the contractor's responsibility to obtain all necessary permits and to follow state guidelines for burning and proper disposal of vegetative materials. Disposal of the trees and shrubs on-site with a chipper is an acceptable alternative to burning. It is imperative that the contractor, in conjunction with the on-site DEP representative, identifies

BUYER CB-23	PAGE 017	REQ. OR PO NO. DEP 14142
SPENDING UNIT WEST VIRGINIA DEPARTMENT OF ENVIRONMENTAL PROTECTION/SPECIAL RECLAMATION		

WV-36a STATE OF WEST VIRGINIA  
Rev. 1/29/02 PURCHASING CONTINUATION SHEET  
VENDOR:

construction limits of the clearing areas. Any timber cut in the clear and grub area that the landowner wishes to retain shall be de-limbed and stockpiled. The areas that will be included in the clearing are all roads, ponds, sludge cells, fill areas, and the clearing limits needed to complete the work called for in these specifications.

#### 5.0 MAINTAIN HAULROAD/ACCESS ROAD

The contractor shall maintain haulroad/access road(s) during the reclamation process to provide access on a well drained surface. The access road to and on the reclamation site shall be graded, sloped, and maintained to drain to provide a road surface free of excessive mud and standing waters at all times while work is in progress. Dust-control measures may be necessary if hauling creates airborne material. Snow removal is to be included in this item.

#### 6.0 NEW ROAD CONSTRUCTION

Access Roads 1 and 1A are new construction. Upon completion of the road fill removal (bid item 3.0) Access Road 1 will be constructed across the newly re-graded area. A two feet high safety berm will be established on the downslope side of Access Road 1.

Access Road 1A will extend from an existing road to the treatment unit as shown on the site plan. All materials required for road construction will be included in this bid item unless otherwise stated.

#### ROAD CONSTRUCTION

The road grades shall be cleared and grubbed of all organic material prior to new road construction. The road shall consist of cuts and fill as necessary to achieve a uniform grade. A ditch will be established to drain the road and culverts and installed where indicated on the Site Plan or as directed by the DEP on site representative. Only suitable material shall be placed on the road, soft areas shall be under cut and removed. Fill shall be placed in compacted lifts not to exceed six (6) inches in thickness to obtain the desired grade and alignment. Compaction equipment is to be approved by DEP on site representative. There are no known utilities in the construction area. Filter Fabric (Tyvar 3401, Mirafi 500X, or equivalent) shall be placed over the completed foundation and covered with a six (6) inch minimum layer of No. 1 limestone (3½ to 1½ inches). The No. 1 stone shall then be covered with 1½ inch crusher run limestone so that the surface is choked off and a three (3) inch minimum layer remains on top. The completed road shall have a minimum width of twelve (12) feet, and the surface shall be crowned and sloped to both sides a minimum of 24-horizontal to 1 vertical. Any fill sections, if used, shall not impound water. The total length of roadside ditch shall be along the entire length of the road. A roadside drainage ditch shall be established along the hillside of the road, and shall be free draining to any culverts crossing under the road. The ditch shall be vegetated and constructed as indicated in the New Access Road drawing. Payment shall be made at the unit price for the measured length of road completed. Any truck turning areas shall be paid as completed length of road.

The contractor shall maintain haulroad/access road(s) during the reclamation process to provide access on a well drained surface. The access road to and on the reclamation site shall be graded, sloped, and maintained to drain to provide a road surface free of excessive mud and standing waters at all times while work is in progress. Dust-control measures may be necessary if hauling creates airborne material. Snow removal is to be included in this item.

#### 7.0 INCIDENTAL LIMESTONE FOR ROADS

Stone shall be 1 1/2" crusher run limestone obtained from any DOH approved quarry. Apply as necessary and compact with roller or other approved equipment by the DEP on site inspector. Contractor shall repair any damage to road after placing stone at no cost to DEP.

Payment shall be made on the unit price and shall be based on weight tickets.

#### 8.0 REGRADE AND TOPSOILING

Concurrent regrading and topsoiling shall immediately follow backfilling of the fill removal area material and shall distribute topsoil or the best available material to support vegetation, as identified by the Department of Environmental Protection contact person, on the surface of the backfill in a smooth, uniform manner. This item shall include the elimination of all rills and gullies, the construction of sediment control sumps, the removal of sediment

BUYER CB-23	PAGE 018	REQ. OR PO NO. DEP 14142
SPENDING UNIT WEST VIRGINIA DEPARTMENT OF ENVIRONMENTAL PROTECTION/SPECIAL RECLAMATION		

WV-36a STATE OF WEST VIRGINIA  
 Rev. 1/29/02 PURCHASING CONTINUATION SHEET  
 VENDOR:

control sumps, the grading of spoil and/or fill materials. Surface shall be free of all rock exceeding six (6) inches in diameter and shall be tracked, track to track. Topsoil presently stockpiled on site shall be preserved and spread on the fill surface. In the absence of stockpiled topsoil, material which can be used as a topsoil substitute shall be identified, segregated, and stockpiled for spreading on the surface. If necessary to manufacture fines, mechanical treatment to pulverize the surface layer shall be required. Regrading and topsoiling shall be conducted prior to and in preparation for the revegetation item.

### 9.0 HAYBALE DIKE

Disturbed areas which have storm water runoff which does not pass through a sediment control structure shall utilize the following method to manage storm water runoff: Max. Bid of \$5.00/LF of Hay Bale Dike.

1. All bales shall be placed on the contour.
2. Bales shall be placed in a row with ends tightly abutting the adjacent bales.
3. Bales shall be securely anchored in place by stakes or rebars driven through the bales. Rebar to be removed at the direction of DEP. The first stake in each bale shall be driven toward previously laid bale to force the bales together. Construction of sumps and/or rock check dams may become necessary to supplement the hay bale dikes, and are incidental to this bid item.

### 10.0 REVEGETATION

The actual seeding date, within the work performance period, shall be at the discretion of the contractor, but a permanent vegetative cover must be established. Verification of materials used shall be required for payment. Seed bed preparation, unless otherwise approved, shall be conducted by industrial disks or tracking with heavy equipment with cleat marks across slope and parallel to the final contours. The surface shall be tracked, track to track. Seeding shall commence after seedbed preparation on a loose and uncompacted soil and with the approval of the Department of Environmental Protection. Contractor shall provide equipment as necessary to secure approval of the seedbed. Revegetation activities shall be carried out in a continuous, concurrent, timely and uniform manner. Failure to do this may result in nonpayment for portions of or the entire Revegetation item. Hydroseeding or broadcast seeding with the approved species is acceptable. The application rate may be increased but the ratio is to remain constant, but no additional monetary compensation will be awarded. Areas outside the limits of construction, disturbed by the contractor, shall be revegetated by the contractor at no expense to DEP. Water utilized for hydroseeding shall be free of injurious or other toxic substances harmful to plant life. The source of water is subject to the approval of the DEP Specialist. It shall be the vendor's responsibility to repeat the procedures under REVEGETATION until a permanent vegetation is established. The acreage quantities in this contract are for bidding purposes only.

A warranty period of one (1) year shall commence upon completion and payment of the revegetation item of the contract. No payment will be made for additional seeding necessary to comply with warranty requirements. The warranty period will be extended for one (1) year from the date of the last augmented seeding done by the contractor. The performance bond and labor and materials bond shall remain in effect throughout the warranty period. The Standards for Evaluating Vegetative Cover as presented in Title 38, CSR2, Section 9 of the West Virginia Surface Mining Reclamation Regulations will apply.

Equipment for the retracking/scarification to eliminate rills and gullies shall be mobilized and utilized to produce slopes consistent with the regrading and topsoiling bid item prior to warranty reseeding. No additional payment will be made by DEP for this warranty work.

### 10.1 AGRICULTURAL LIME

Unless otherwise specified, all lime used shall be registered with the West Virginia Department of Agriculture, have an 85% minimum calcium carbonate equivalent, and meet the fineness classification no larger than that for ground lime. The following fineness classifications or combinations of lime are acceptable:

Pulverized - 100% passing a U.S. Standard 20 mesh sieve

BUYER CB-23	PAGE 019	REQ. OR PO NO. DEP 14142
SPENDING UNIT		
WEST VIRGINIA DEPARTMENT OF ENVIRONMENTAL PROTECTION/SPECIAL RECLAMATION		

WV-36a STATE OF WEST VIRGINIA  
 Rev. 1/29/02 PURCHASING CONTINUATION SHEET  
 VENDOR:

- 70% passing a U.S. Standard 100 mesh sieve
- Ground - 90% passing a U.S. Standard 20 mesh sieve
- 50% passing a U.S. Standard 60 mesh sieve
- 35% passing a U.S. Standard 100 mesh sieve

Use of blends and low-grade agricultural liming materials shall require prior approval. Lime shall be spread as soon as possible after delivery to site. Lime shall be applied evenly and uniformly distributed over the treated area. Lime shall be thoroughly mixed into the soil material. Lime subjected to adverse conditions before spreading will be deemed unacceptable. Failure to complete this phase shall result in nonpayment of this bid item.

Lime Applied at 10 ton/acre.

### 10.2 FERTILIZER

Fertilizer rates given for REVEGETATION are for 1,000 lbs. of 10-20-20 per acre. These rates are minimum and for bidding purposes.

Fertilizer shall be applied evenly and uniformly distributed over the treated area. Common complete fertilizers which meet the minimum standards are acceptable.

### 10.3 MULCH

Acceptable mulch for this project is wood fiber, hay, or straw.

Mulch: Wood Fiber @ 1.0 ton/Acre

Hay or straw mulch may be substituted at a rate of 2 tons/Acre

### 10.4 VEGETATIVE SPECIES

Seeding rate required is for pure live seed (pls) in pounds per acre. The use of annuals or cover crops will not be considered for vegetative success.

#### NORTH MIX

<u>VEGETATIVE SPECIES</u> <sup>1</sup>	<u>RATE/ACRE</u> <sup>1</sup>
Orchard Grass	@ 15 lbs/acre
Birdsfoot Trefoil <sup>2</sup>	@ 15 lbs/acre
Yellow Sweet Clover	@ 5 lbs/acre
Red Clover	@ 10 lbs/acre
Ky 31 Fescue	@ 15 lbs/acre
Foxtail Millet <sup>3</sup>	@ 12 lbs/acre
Wheat or Rye <sup>4</sup>	@ 50 lbs/acre

1. Seeding rate suggested is for pure live seed (pls) in pounds per acre.
2. Herbaceous legumes must be treated with the appropriate bacterium before seeding.
3. Spring mix.
4. Fall mix.

BUYER CB-23	PAGE 020	REQ. OR PO NO. DEP 14142
SPENDING UNIT WEST VIRGINIA DEPARTMENT OF ENVIRONMENTAL PROTECTION/SPECIAL RECLAMATION		

WV-36a STATE OF WEST VIRGINIA  
 Rev. 1/29/02 PURCHASING CONTINUATION SHEET  
 VENDOR:

**11.0 CONSTRUCTED SLUDGE DISPOSAL CELL**

A sludge disposal cell shall be constructed adjacent to an existing cell to receive sludge pumped from the settling ponds and will be constructed in the area designated on the Site Plan. The cell shall have a volume of 128,000 cubic feet with bottom dimensions of 140 feet by 60 feet. The depth will be 8 feet of sludge with 2 feet of freeboard. The total depth will be 10 feet. Side slopes shall be no steeper than one horizontal to one vertical. The outside embankment shall have a 12 feet minimum top width. The shape of the cell may be adjusted to fit site conditions with the approval of the DEP on site representative. Each cell will have a riprap trapezoidal exit channel with a minimum top width of 6 feet and 2:1 side slopes. Use standard R-5 riprap (limestone). Embankments shall be constructed in six (6) inch compacted layers with all stones larger than 6 inches being removed. Remove all vegetation from site prior to initiating construction. The exit channels shall be paid under a separate bid item. The sludge cell shall be paid as a lump sum item at completion of work.

**12.0 TRAPEZOIDAL RIPRAP CHANNEL**

Provide all materials, excavate and construct trapezoidal channel as indicated on the attached typical plans, cross-section, specifications, and as discussed at the Pre-Bid Showing. Channels and ditches shall be free draining upon completion of construction. Length of channel may be adjusted to meet on site conditions. (See riprap specifications) R-5 limestone riprap shall be used at a thickness of 1 1/2 feet.

**13.0 DRIVE WATER COLLECTION POND**

A pond will be constructed in order to collect water to drive the Aquafix Unit. A 4 inch HDPE supply line will be plumbed into the pond riser intake unit (bid item 14.0). The 4 inch line will drive the Aquafix unit. A 6 inch HDPE line shall be installed in the riser intake unit two (2) inches above the 4 inch HDPE line. The 6 inch line will supply water through the concrete treatment channel. The pond will also have a trapezoidal exit channel for a spillway as specified on bid item 12.0. See the attached drawings for location of pond and the pond dimensions.

**14.0 RISER INTAKE UNIT**

The foundation shall be Type II sulfate resistant concrete and shall conform to the dimensions and shape shown in the detail drawings and specifications. Include all reinforcing bars with supports as necessary. Provide all forms, personnel and equipment required for the placement, finishing, and curing of the concrete. The concrete shall be consolidated with use of an internal spud vibrator to liquefy the concrete so that entrapped air and water can come to the surface. Adverse weather conditions shall be avoided during completion of this item. WVDOH specifications for concrete shall apply to this item. Excavation for the foundation is incidental to this item with no separate payment being made.

The sub-foundation shall be undercut to remove all unconsolidated material down to a competent foundation as determined by the DEP on site representative. The DEP on site representative shall be present during this work. If the foundation site is over excavated, durable rock may be added and compacted in six (6) inch layers to obtain a solid foundation.

The 30 inch diameter HDPE riser shall be anchored into the foundation with rebar as shown in the detail drawings and specifications. A minimum of sixty, evenly spaced, one inch diameter perforations in the 30" HDPE Riser shall conform to the dimensions, location, and shape shown in the detail drawings and specifications. Riprap (6"-12" non-calcareous) shall be placed around the 30 inch HDPE riser to allow water to flow into the perforated riser. Allow enough riprap to cover a minimum of a twelve (12) feet diameter area around the riser pipe.

An aluminum lid shall be fabricated to cover the 30 inch HDPE riser. The aluminum cover shall be attached to the riser, easily opened, and at least 3/16 inch thick.

**15.0 POND CLEANING AND MODIFICATION**

Sediment from the existing treatment pond shall be removed to a depth of 10 feet. Material excavated from the pond will be placed in the Spoil Disposal Area as indicated on the site plan.

The existing dike dividing the pond shall be reinforced by building up the upstream and downstream faces

BUYER CB-23	PAGE 021	REQ. OR PO NO. DEP 14142
SPENDING UNIT WEST VIRGINIA DEPARTMENT OF ENVIRONMENTAL PROTECTION/SPECIAL RECLAMATION		

WV-36a STATE OF WEST VIRGINIA  
 Rev. 1/29/02 PURCHASING CONTINUATION SHEET  
 VENDOR:

of the dike to a minimum top width of 20 feet, and add an additional 2.0 foot of freeboard. Material for dike reinforcement shall be obtained from locations approved by the on site DEP inspector. Water shall pass through the top of the dike at one end with riprap channel to protect the slopes and crossing from erosion. This channel crossing shall be paid as Trapezoidal Exit Spillway Channel paid under bid item 17.0.

Structures shall be cleaned out if the sediment capacity reaches 60% after initial cleaning, repaired, and maintained until demobilization. Secondary clean-out and maintenance shall be conducted by the contractor at no expense to DEP. This is a lump sum bid item to be paid 50% at completion of pond cleaning, and the other 50% at completion of dike reinforcement and channel crossing installation.

**16.0 BAFFLE CURTAIN**

The baffle curtain shall be of an ultraviolet (UV) resistant type vinyl coated polyester material with a minimum total weight rating of 17 oz./sq. yd. Styrofoam floats of size 3"x4"x12" shall be hot seam sealed into the top of baffle curtain, and shall be evenly spaced 4 inches apart end to end. A grommet shall be placed between each of the styrofoam floats. A 5/16 inch diameter stainless steel wire cable shall be seamed into the top of the baffle to anchor at the sides of the pond. A ¼ inch diameter link chain shall be hot seam sealed into the bottom of the baffle for weight, and to anchor at the sides of the pond. Secure anchor points (pipe, rods, or treated posts) shall be installed at the ponds edge to hold the baffle in place. Anchor points and the baffle location shall be approved by the DEP onsite representative before installation. The wire cable and chain shall be attached in such a way to allow for easy disconnect while sludge is being pumped from the pond. All cable fasteners, eye bolts, and other accessories shall be stainless steel to prevent corrosion, and shall be incidental to this pay item. The baffle curtain opening slots shall be cut into the curtain below the hot seam seal at the top of the baffle, as indicated on the attached drawing. The spacing and the size of the slots shall be determined by the DEP engineer or onsite representative. Payment shall be per linear feet of curtain installed at two locations.

**17.0 TRAPEZOIDAL EXIT SPILLWAY CHANNEL**

A final exit channel shall be constructed in the original exit channel location consisting of a 12" HDPE pipe (bid item 25.0) and a ten (10) foot bottom width riprap channel. Freeboard shall be 3 feet measured from the invert of the 12" HDPE pipe. Refer to the attached drawing for additional details.

**18.0 FRESHWATER DIVERSION DITCH**

A freshwater diversion ditch will be constructed to convey water from an unnamed tributary of Laurel Run around the site.

Provide all materials, excavate and construct Ditch as indicated on the attached site drawings, cross-section, specifications, and/or discussions at the Pre-Bid Showing. Ditches shall be free draining upon completion of construction. Length of ditch may be adjusted to meet on site conditions. No separate payment for construction stakeout will be made. Limestone riprap R-5 shall be utilized at a thickness of 1 ½ ft.

**19.0 RIPRAP V-DITCH**

Provide all materials, excavate and construct Ditch as indicated on the attached typical plans, cross-section, specifications, and/or discussions at the Pre-Bid Showing. Ditch shall be free draining and impervious upon completion of construction. Length of ditch may be adjusted to meet site conditions. No separate payment for construction stakeout will be made. Payment shall be for completed length of ditch. Limestone riprap R-5 shall be utilized at a thickness of 1 ½ ft.

**20.0 GROUTED RIPRAP DITCH**

Grouted riprap ditches will be constructed to convey water from the 48 inch culvert on Access Road 1A to Settling Pond 1 and from the treatment site to this ditch. The ditches shall have side slopes at 2 horizontal:1 vertical. The channel will have a three (3) foot flat bottom, one and one half (1½) foot thick blanket of stone and one (1) foot of freeboard. The ditch shall have a top of rock width of eleven (11) feet and a depth of the ditch of two (2) feet.

BUYER CB-23	PAGE 022	REQ. OR PO NO. DEP 14142
SPENDING UNIT		
WEST VIRGINIA DEPARTMENT OF ENVIRONMENTAL PROTECTION/SPECIAL RECLAMATION		

WV-36a STATE OF WEST VIRGINIA  
 Rev. 1/29/02 PURCHASING CONTINUATION SHEET  
 VENDOR:

Standard R-5 limestone rip rap shall be utilized.

The grout filler shall be composed of a mixture of one part Type II (sulfate resistant) portland cement and three parts sand, mixed with water to produce a workable consistency. The stone shall be thoroughly wet immediately before grout is applied. As soon as the grout is deposited on the surface, it shall be thoroughly worked into the joints. The stones shall then be brushed, so that their top surfaces are exposed. Grout shall penetrate 100% of the riprap thickness. See site plan for ditch locations.

### 21.0 SEEP COLLECTOR

Collection underdrains shall be constructed to collect all seep water for conveyance to the treatment sites. The collection underdrain shall be 4 ft. X 4 ft. in cross-section. Stone for the underdrain shall be non-calcareous with a size of 3" to 6" in diameter. The drain shall be wrapped with filter fabric (Tyvar 3401 or equivalent). Filter fabric may be omitted from areas where the seepage enters the underdrain if approved by the DEP on site representative. A 12" perforated SDR-35 PVC pipe shall extend the length of the underdrain and connect to solid pipe. The solid pipe shall daylight to the V-ditch leading into the collection pond. An animal guard shall be installed on the exit of the pipe. The perforated end of the 12" pipe seep collector shall extend to the surface as a clean-out and may be reduced to 6" diameter pipe with a cap.

Cover the underdrain with a minimum of 1 ft. of material and grade the surface so it is well drained. Material on the downslope side of the drain shall be impervious to prevent leakage from the underdrain to the surface. Provide all fittings necessary for installation. Refer to the attached drawing for further details. All materials specified above and on the attached drawing shall be incidental to this bid item.

### 22.0 4 INCH HDPE DRIVE LINE PIPE

Pipe shall be 4 inch diameter, SDR 15.5 or 17 HDPE of standard manufacture. Install to manufacturers recommendations. Install the pipe as indicated in the specifications and/or as shown on the drawings.

Payment is for the actual length of pipe installed. This 4 inch HDPE pipe shall be used for water conveyance from the drive water collection pond riser intake unit to the Aquafix unit. Provide all materials, equipment and personnel necessary for installation. Pipe shall be buried at least 2.5 feet deep. Use butt weld fusion process to join pipes. A qualified fusion technician shall supervise the fusion of all joints. See site plan for approximate location.

### 23.0 WATER CONNECTION AT DISPENSING UNIT

At the dispensing unit, the 4 inch diameter HDPE line (bid item 22.0) shall be connected with a four (4) inch True union PVC ball valve and a two (2) inch True union PVC ball valve, various HDPE fittings (see Drive Line Schematic drawing), cleanouts, molded elbows, caps, reducer fittings, and flanges to supply water to the unit. This is a lump sum payment upon completion of work. All material costs are incidental to this bid item.

### 24.0 6 INCH HDPE SLUDGE PIPE

Pipe shall be 6 inch diameter, SDR 15.5 or 17 HDPE of standard manufacture. Install to manufacturers recommendations. Install the pipe as indicated in the specifications and/or as shown on the drawings.

Payment is for the actual length of pipe installed. This 6 inch HDPE pipe shall be used for sludge line, a bypass feed line to the collection pond, and a supply line to the treatment channel. Provide all materials, equipment and personnel necessary for installation. Pipe shall be buried at least 2.5 feet deep. Use butt weld fusion process to join pipes. A qualified fusion technician shall supervise the fusion of all joints. See site plan for location.

### 25.0 12 INCH HDPE PIPE

Pipe shall be 12 inch diameter, SDR 15.5 or 17 HDPE of standard manufacture. Install to manufacturers recommendations. Install the pipe as indicated in the specifications and/or as shown on the drawings.

Payment is for the actual length of pipe installed. This 12 inch HDPE pipe shall be used for spillway installation and additional haulroad/access road culverts. Provide all materials, equipment and personnel necessary for installation. Pipe shall be buried at least 2.5 feet deep. Use butt fusion process to join pipes. A qualified fusion



BUYER CB-23	PAGE 023	REQ. OR PO NO. DEP 14142
SPENDING UNIT		
WEST VIRGINIA DEPARTMENT OF ENVIRONMENTAL PROTECTION/SPECIAL RECLAMATION		

WV-36a STATE OF WEST VIRGINIA  
 Rev. 1/29/02 PURCHASING CONTINUATION SHEET  
 VENDOR:

technician shall supervise the fusion of all joints. Use compactors or hand operated tampers to obtain compaction of material around the HDPE pipe to prevent any leakage or piping of water from pond.

**26.0 30 INCH HDPE CULVERT PIPE**

The culvert shall be HDPE, dual wall smooth interior corrugated twenty (20) foot joint type. The pipe joints shall be silt-tight and the pipe shall meet ASTM D3350 manufacturing standards. The culvert locations shall be determined by the onsite DEP representative.

**STANDARD INSTALLATION**

Culverts installed in access roads shall cross the road at a 30 degree angle downgrade with a minimum grade of three percent (3%) from inlet to outlet, except in streams or diversion ditches where the pipe shall be installed straight and coincide with the normal direction of flow.

The culvert inlet and outlet ends shall be protected by a headwall of stable non-erodible material and the slope at the outlet shall be protected with an apron of rock riprap, energy dissipater or other designated material. The culvert shall be installed in a trench excavated in solid undisturbed ground or formed by compacted earth.

The culvert shall be imbedded in a formed trench to a depth no less than 1/10 the outside diameter of the pipe. Selected backfill material shall be placed around the culvert in four (4) inch layers and thoroughly compacted by means of hand tamping or manually directed power tampers or plate vibrators.

The culvert shall be covered with a minimum of twelve (12) inches of material. Payment shall be for length of culvert installed.

**27.0 36 INCH HDPE CULVERT PIPE**

The culvert shall be HDPE, dual wall smooth interior corrugated twenty (20) foot joint type. The pipe joints shall be silt-tight and the pipe shall meet ASTM D3350 manufacturing standards. The culvert locations shall be determined by the onsite DEP representative.

**STANDARD INSTALLATION**

Culverts installed in access roads shall cross the road at a 30 degree angle downgrade with a minimum grade of three percent (3%) from inlet to outlet, except in streams or diversion ditches where the pipe shall be installed straight and coincide with the normal direction of flow.

The culvert inlet and outlet ends shall be protected by a headwall of stable non-erodible material and the slope at the outlet shall be protected with an apron of rock riprap, energy dissipater or other designated material. The culvert shall be installed in a trench excavated in solid undisturbed ground or formed by compacted earth.

The culvert shall be imbedded in a formed trench to a depth no less than 1/10 the outside diameter of the pipe. Selected backfill material shall be placed around the culvert in four (4) inch layers and thoroughly compacted by means of hand tamping or manually directed power tampers or plate vibrators.

The culvert shall be covered with a minimum of twelve (12) inches of material. Payment shall be for length of culvert installed.

**28.0 48 INCH HDPE CULVERT PIPE**

The culvert shall be HDPE, dual wall smooth interior corrugated twenty (20) foot joint type. The pipe joints shall be silt-tight and the pipe shall meet ASTM D3350 manufacturing standards. The culvert locations shall be determined by the onsite DEP representative.

**STANDARD INSTALLATION**

Culverts installed in access roads shall cross the road at a 30 degree angle downgrade with a minimum grade of three percent (3%) from inlet to outlet, except in streams or diversion ditches where the pipe shall be installed straight and coincide with the normal direction of flow.

The culvert inlet and outlet ends shall be protected by a headwall of stable non-erodible material and the

BUYER CB-23	PAGE 024	REQ. OR PO NO. DEP 14142
SPENDING UNIT WEST VIRGINIA DEPARTMENT OF ENVIRONMENTAL PROTECTION/SPECIAL RECLAMATION		

WV-36a STATE OF WEST VIRGINIA  
 Rev. 1/29/02 PURCHASING CONTINUATION SHEET  
 VENDOR:

slope at the outlet shall be protected with an apron of rock riprap, energy dissipater or other designated material. The culvert shall be installed in a trench excavated in solid undisturbed ground or formed by compacted earth.

The culvert shall be imbedded in a formed trench to a depth no less than 1/10 the outside diameter of the pipe. Selected backfill material shall be placed around the culvert in four (4) inch layers and thoroughly compacted by means of hand tamping or manually directed power tampers or plate vibrators.

The culvert shall be covered with a minimum of twelve (12) inches of material. Payment shall be for length of culvert installed.

**29.0 PUMP ADAPTOR CONNECTION**

The pond ends of the HDPE 6 inch diameter pipe shall be fitted with a threaded adaptor to receive a 6 inch cam-lock adaptor. Install posts or pipes to protect outlet from damage. Use riprap around pipe as necessary. Include a cam-lock cap for sealing each adaptor. The cap shall withstand pressures developed during pumping at other pumping points. The sludge disposal pond ends will be the same as the pond ends. Payment shall be for each location installed.

**30.0 TEE (6 INCH HDPE TEE 90°)**

Tees shall be of standard manufacture for 6 inch diameter HDPE pipe to allow 90° junction. Use butt weld fusion process to join fittings to pipes. A qualified fusion technician shall supervise the fusion of all joints. Payment shall be for each location installed.

**31.0 WYES (6 INCH HDPE LATERALS 45°)**

Wyes shall be of standard manufacture for 6 inch diameter HDPE pipe to allow 45° junction. Use butt weld fusion process to join fittings to pipes. A qualified fusion technician shall supervise the fusion of all joints. Payment shall be for each location installed.

**32.0 FLANGE (6 INCH HDPE)**

Near one end of the 6 inch HDPE line from the water diversion ditch, two 6-inch HDPE flanges shall be installed to the manufacturer's standards for installation of a gate valve. Use butt weld fusion process to join fittings to pipes. A qualified fusion technician shall supervise the fusion of all joints. Payment shall be for each location installed.

**33.0 6-INCH GATE VALVE**

One 6 inch epoxy coated cast iron gate valve with flanged ends shall be provided and installed on the flanged end of the 6 inch diameter HDPE line. The valve shall have a 2 inch square top nut, and resilient wedge gate type meeting AWWA C509 standards. A 2 inch square valve box key wrench shall be provided, and is incidental to this bid item. A piece of SDR 35 PVC pipe and cap shall be provided for a riser to access the valve. Appropriate rubber flange gaskets and stainless steel bolts/nuts shall also be incidental to this bid item.

**34.0 FOUNDATION**

The foundation shall be Type II (Sulfate Resistant) Concrete and shall conform to the dimensions and shape shown in the detail drawings and specifications. Include all reinforcing bars with supports and anchor bolts as necessary. Provide all forms, personnel and equipment required for the placement, finishing, and curing of the concrete. The concrete shall be consolidated with use of an internal spud vibrator to liquefy the concrete so that entrapped air and water can come to the surface. Adverse weather conditions shall be avoided during completion of this item. WVDOH specifications (Section 601-Construction Manual) for concrete shall apply to this item. Concrete shall cure for a minimum of 5 to 7 days before the silo may be erected in place. Excavation for the foundation is incidental to this item with no separate payment being made. Concrete shall have a minimum 28-day test strength of 4000 psi.

The channel in the foundation is to receive water from a 6 inch HDPE pipe from the collection pond. After

BUYER CB-23	PAGE 125	REQ. OR PO NO. DEP 14142
SPENDING UNIT WEST VIRGINIA DEPARTMENT OF ENVIRONMENTAL PROTECTION/SPECIAL RECLAMATION		

WV-36a STATE OF WEST VIRGINIA  
 Rev. 1/29/02 PURCHASING CONTINUATION SHEET  
 VENDOR:

treatment with the reagent the water will exit the concrete channel into a grouted riprap ditch. The top of the foundation elevation shall be a minimum of 7 feet below the water level in the water intake riser. See attachment for details on sulfate resistant concrete.

This item shall be paid for as a lump sum item after completion of the foundation and acceptance by the DEP.

**35.0 SUB FOUNDATION AND PREPARATION**

The sub-foundation shall be undercut to remove all fill (unconsolidated material) down to a competent foundation as determined by the on site DEP representative. The sub-foundation shall be constructed in substantial conformity to the plans and/or specifications. The DEP on site representative shall be present during this work.

The sub-foundation material shall be suitable material free of particles larger than three inches in diameter and consist of granular material conforming to WVDOH specification 716.1.1.2. A bearing capacity of approximately 6 tons per square ft. shall be obtained.

Compaction shall be done with a suitable compactor to obtain approximately 98% Standard Proctor Density. Layers shall be six (6) inches or less in thickness before compaction is initiated. Moisture content of the fill material shall be controlled to obtain maximum compaction.

Payment shall be made for each one (1) foot depth of undercut required.

**36.0 CRANE**

This shall include furnishing a crane of sufficient capacity to unload and erect the silo structure on its foundation and to install the reagent dispensing unit. The silo is estimated to weigh 20 to 25 tons and have an in place height of 45 feet.

Payment for this work shall be made based on the lump sum contract and paid upon final acceptance by DEP.

**37.0 DOSING UNIT AND SILO**

This item includes all work necessary to purchase, install and initiate operation of an Aqua-Fix water powered dosing unit (Unit type MSS-SM-OA-30). This item shall be subcontracted to:

Aqua-Fix, Water Treatment Systems.  
 Michael Jenkins  
 301 Maple Lane  
 Kingwood, WV 26537 Telephone: (304) 329-1056.

Changes to these specifications shall be made only with the written approval of the Program Manager.

A 30 ton steel silo to store the reagent is required. The silo shall be equipped with an interior ladder, an exterior ladder with a protective cage and a lockable steel safety door, a steel safety fence around the top of the silo, a filler pipe to extend to the unloading port, a steel cone at the base of the silo to direct the discharge of the reagent through a steel flange which is sized and located to accommodate the reagent dispensing unit. The silo shall include a vent pipe to prevent pressure buildup during filling. An emergency pop off valve shall be included in case the vent pipe malfunctions. Pneumatic filling of the silo is to be utilized.

Structural elements shall be warranted by the manufacturer to with stand normal static and dynamic loads as commonly accepted by industry.

An insulated steel security enclosure attached to the silo structure support system to protect the dosing unit from vandalism and the weather is required. The wall thickness of the silo enclosure shall be a minimum of 1/8 inch thick steel. The enclosure shall be equipped with a hinged, lockable steel door of sufficient size to facilitate removal of the dosing unit for repair and/or future replacement. The enclosed structure shall be fitted with a propane heat unit with a capacity to prevent freezing of the dosing unit during the winter. The heater will include all needed piping, regulator and fittings to connect to the tank. The tank will be a five hundred (500) gallon capacity and it will need filled one time.

BUYER CB-23	PAGE 026	REQ. OR PO NO. DEP 14142
SPENDING UNIT WEST VIRGINIA DEPARTMENT OF ENVIRONMENTAL PROTECTION/SPECIAL RECLAMATION		

WV-36a STATE OF WEST VIRGINIA  
 Rev. 1/29/02 PURCHASING CONTINUATION SHEET  
 VENDOR:

Painting of the silo and steel security enclosure shall be done in accordance with WVDOH Specification 711. Preferred colors are green and/or tan.

The dosing unit, silo, and filler pipe shall be designed to facilitate the use of Calcium Oxide (CaO) during the service life of the unit. This portion of the work shall include the initial filling and the start up of the unit, at the direction of the Program Manager, to confirm that all units function as intended. Any repairs and/or adjustments required to the unloading system and dosing unit to allow them to function as designed shall be performed at no cost to the DEP. The system shall be operated successfully for a one-week period before acceptance by the DEP. All settling ponds and rip-rap ditches leading to them must be completed before testing is initiated. The Calcium Oxide shall be 30 tons in amount and delivered as scheduled by the on site DEP representative. Payment for all of the work specified above shall be made based on the lump sum contract price for each unit.

**38.0 STRUCTURE AND/OR DEBRIS REMOVAL**

All existing man-made items particular to the site and not to be utilized in the total reclamation of this site shall be demolished (if necessary) and disposed of in a legal manner. All iron, steel, aluminum, or any other metal, plastic, or any other man made material, including but not limited to I-Beams, Angle Iron, Channel Iron, Corrugated Metal, Flat Metal, Floc Drums, Grease Drums, Pipe or Conduit is to be dismantled, removed and properly disposed of off site and according to state, local, and federal requirements. These structures are identified as: abandoned storage buildings, office trailer, discarded pipes and storage tanks.

**39.0 EXISTING ROAD DITCH REPAIR**

A section of existing road ditch shall be cleaned and reconstructed to original condition. The ditch shall have side slopes of 2:horizontal to 1:vertical and a depth of 2 feet. The shape shall be trapezoidal with a 2 feet wide bottom. Stone already in place will be used as rip rap for the reconstructed ditch. See site plan for location.

BUYER CB-23	PAGE 027	REQ. OR PO NO. DEP 14142
SPENDING UNIT WEST VIRGINIA DEPARTMENT OF ENVIRONMENTAL PROTECTION/SPECIAL RECLAMATION		

WV-36a                      STATE OF WEST VIRGINIA  
Rev. 1/29/02              PURCHASING CONTINUATION SHEET  
VENDOR:

---

## **BID PREPARATION INFORMATION**

### **HISTORICAL INFORMATION**

Prospective bidders may review files at the West Virginia Department of Environmental Protection, Charleston, WV office, or the Regional West Virginia Department of Environmental Protection Office at 105 South Railroad St., Philippi, WV 26416. These files may contain additional information not included in the contract. Documents including, but not limited to, permit applications, permits, inspection reports, environmental documents, permit violation history, geological and geotechnical information, probable hydrologic consequences, maps, modifications, NPDES information and other related data. Copies may be obtained upon request and payment of copying fees.

### **EXAMINATION OF BID PACKAGE AND SITE OF WORK**

The bidder is required to examine, carefully, the bid package (plans, specifications, supplemental specifications, contract forms, etc.) and the site of the work contemplated. The submission of a bid shall be considered prima facie evidence that the bidder has made such examination and has judged for and satisfied themselves as to the character, quantity, and quality of work to be performed and the materials required to be furnished under the contract.

### **PREBID CONFERENCE**

Only the prospective bidders on the sign-in sheet in attendance for the entire Pre-Bid Conference will be eligible to submit bids for consideration of this project.

### **VIDEO**

The information given at the pre-bid showing by the project contact person or the assigned person shall be documented on video tape and shall be an integral part of this contract's requirements, but will not supersede the written contract. All information on video tape that is new or provides clarification to the specifications will be issued in writing by a formal addendum and will become part of the written contract.

### **INTENT OF CONTRACT**

The intent of the contract is for the reclamation/restoration of forfeited mine lands as required by West Virginia Department of Environmental Protection. The contractor is to provide for the construction and completion in every detail of the work described. The Contractor shall furnish all labor, materials, equipment, tools, transportation, and supplies required to complete the work in accordance with the Plans, Specifications, and terms of the Contract.

Should any misunderstanding arise as to the intent or meaning of the Contract, or any discrepancy appear, the decision of the Director of Division of Land Restoration shall be final.

BUYER CB-23	PAGE 028	REQ. OR PO NO. DEP 14142
SPENDING UNIT WEST VIRGINIA DEPARTMENT OF ENVIRONMENTAL PROTECTION/SPECIAL RECLAMATION		

WV-36a STATE OF WEST VIRGINIA  
 Rev. 1/29/02 PURCHASING CONTINUATION SHEET  
 VENDOR:

## GENERAL PERFORMANCE STANDARDS

### INTRODUCTION

The performance standards and non-compliance penalties which govern special reclamation-bond forfeiture projects are in Chapter 22A, Article 3, of the Code of West Virginia and subsequent rules and regulations. The following performance standards are of a general nature and do not represent all the performance standards applicable to a special reclamation-bond forfeiture project. However, some or all of these standards will pertain to each project.

### BACKFILLING

1. Unless otherwise noted, the highwall shall be eliminated and the disturbed area graded to the approximate original contour.
2. The material used to backfill and eliminate the highwall shall be sufficiently compacted so as to insure stability of the backfill throughout the warranty period.
3. The land above the highwall shall not be disturbed unless otherwise directed.
4. The best available material to support vegetation, sufficient to establish a permanent vegetative cover and to achieve the approved post mining land use, shall be used.

### BLASTING

The performance standards of the blasting regulations must be adhered to.

### LIFE OF CONTRACT

The purchase order contract becomes effective on the starting date as specified in the notice to proceed as issued by the Department of Environmental Protection. This contract extends for a period of one (1) year and may be renewed until such "reasonable time" thereafter as is necessary to complete the payment therefore. A responsible Contractor's Agent shall be on the site at all working times who demonstrates a knowledge of mined land reclamation, contract requirements and responds to DEP (owner) inspections.

### WORK PERFORMANCE PERIOD

The work performance period is a defined portion of the contract in which all items shall be completed. The work performance period is to be performed within 365 calendar days. Extensions may be granted based upon contractor's performance, weather conditions and site-specific site conditions.

### NOTICE TO PROCEED

A notice to proceed shall be issued to the Contractor by the project contact person for the Department of Environmental Protection. Actual construction may only begin after a Notice to Proceed is given and as specified. Such notice shall specify the starting date of the Purchase Order, the work performance period, and the completion date of the work performance period.

### PRE-CONSTRUCTION CONFERENCE

The Contractor in possession of the awarded purchase order shall schedule a Pre-Construction Conference on the site within ten (10) days after receiving the Notice To Proceed. The Contractor's foreman or the on-the-ground supervisor must be in attendance.

BUYER CB-23	PAGE 029	REQ. OR PO NO. DEP 14142
SPENDING UNIT		
WEST VIRGINIA DEPARTMENT OF ENVIRONMENTAL PROTECTION/SPECIAL RECLAMATION		

WV-36a                      STATE OF WEST VIRGINIA  
Rev. 1/29/02      PURCHASING CONTINUATION SHEET  
VENDOR:

---

**GENERAL SUPERVISION** - This contract is under the general supervision of the West Virginia Department of Environmental Protection's contact person for the purpose of contract compliance inspection only. Contractor shall supervise work being conducted at all times. All services rendered by the Engineer/Contact Person consist of professional opinions and recommendations made in accordance with generally accepted engineering practice. Under no circumstances is it the intent of the Engineer/Contact Person to directly control the physical activities of the Contractor or the Contractor's workmen's accomplishment of work on this project.

**CONTRACTOR RESPONSIBILITY**

The contractor is responsible for compliance with all aspects of this written contract. No changes will be honored without prior approval from the Program Supervisor.

**LAWS TO BE OBSERVED**

The Contractor shall keep fully informed of all Federal and State laws, all local laws, ordinances, and regulations and all orders and decrees of bodies or tribunals having any jurisdiction or authority, which in any manner affect those engaged or employed on the work, or which in any way affect the conduct of the work. The Contractor shall at all times observe and comply with all such laws, ordinances, regulations, orders and decrees; and shall protect and indemnify the State and its representatives against any claim or liability arising from or based on the violation of any such laws, ordinances, regulations, orders, or decrees, whether by themselves, their subcontractors or their employees.

**PERMITS, LICENSES AND TAXES**

The Contractor shall procure all permits and licenses, pay all charges, fees, and taxes, and give all notices necessary and incidental to the due and lawful prosecution of the work.

**CONCURRENT RECLAMATION**

Reclamation of this project shall commence at a definite point as defined and shall progress from that point with total reclamation to include backfilling, grading/regrading, and revegetation. Changes may be granted based upon weather or differing site conditions with prior approval.

BUYER CB-23	PAGE 030	REQ. OR PO NO. DEP 14142
SPENDING UNIT WEST VIRGINIA DEPARTMENT OF ENVIRONMENTAL PROTECTION/SPECIAL RECLAMATION		

WV-36a STATE OF WEST VIRGINIA  
 Rev. 1/29/02 PURCHASING CONTINUATION SHEET  
 VENDOR:

**WATER QUALITY CONTROL**

Shall commence with initial start-up of the project and remain in effect for the extent of the backfilling, regrading and revegetation activity. DEP obtains a storm water permit for each project from the Water Resources Division. (General Water Pollution Control Permit WVO115924) The Contractor is responsible for performing the best management practices. Adequate facilities shall be installed, operated and maintained using the best management practices of the U.S. Environmental Protection Agency's Non-Point Source (NPS) Program for sediment control during the active reclamation. The contractor shall take any and all steps necessary to prevent erosion or silting problems from occurring and to minimize pollution or sedimentation of the stream. If any such problems develop, the contractor shall be responsible to take immediate corrective action. No separate payment for this work will be honored. All impounded waters which require removal during reclamation, shall be pumped with appropriate measures taken to prevent erosion from the discharge. The contractor shall be responsible for treatment of said waters to meet pH standards. The water shall be discharged only when the quality meets a pH equivalent to the pH of the receiving stream but not less than 6.0.

**DIFFERING SITE CONDITIONS**

During the progress of the work, if subsurface or latent physical conditions are encountered at the site differing materially from those indicated in the contract or if unknown physical conditions of an unusual nature, differing materially from those ordinarily encountered and generally recognized as inherent in the work provided by the contract, are encountered at the site, the party discovering such conditions shall promptly notify the other party in writing of the specific differing conditions before they are disturbed and before the affected work is performed.

Upon written notification, the Engineer/Contact Person will investigate the conditions, and if determined that the conditions materially differ and cause an increase or decrease in the cost or time required for the performance of any work under the contract, an adjustment, excluding loss of anticipated profits, will be made and the contract modified in writing accordingly. The Engineer/Contact Person will notify the Contractor of DEP's determination whether or not an adjustment of the contract is warranted.

No contract adjustment which results in a benefit to the Contractor will be allowed unless the Contractor has provided the required written notice.

No contract adjustment will be allowed under this clause for any effects caused on unchanged work.

**HANDLING AND STORAGE OF MATERIALS**

Materials which are stored on site, before utilization, shall be stored so as to assure the preservation of their quality and fitness for the work. Stored materials, even though approved before storage, may be inspected again prior to their use in the work. Damaged or deteriorated materials shall be removed and replaced by materials meeting the original specifications.

Aggregate stockpiles shall be made on ground that is denuded of vegetation, hard, and well drained. Removal of aggregate from the stockpile shall be done in a manner which will not result in the inclusion of foreign material into the aggregate. The use of the aggregate will determine if exceptions are permitted.

All materials shall be handled in such a manner as to preserve their quality and fitness for the work.

**MAINTENANCE DURING CONSTRUCTION**

The contractor shall maintain the work during construction and until the project is accepted. All cost of maintenance work during construction and before the project is accepted shall be included in the unit or lump sum prices on the various pay items.



BUYER CB-23	PAGE 031	REQ. OR PO NO. DEP 14142
SPENDING UNIT WEST VIRGINIA DEPARTMENT OF ENVIRONMENTAL PROTECTION/SPECIAL RECLAMATION		

WV-36a STATE OF WEST VIRGINIA  
 Rev. 1/29/02 PURCHASING CONTINUATION SHEET  
 VENDOR:

**FINAL INSPECTION**

A final inspection meeting by the Department of Environmental Protection's Specialist and the contractor is required for the construction phase and prior to demobilization.

**ACREAGE QUANTITIES**

The acreage quantities in this contract are for bidding purpose and are set (definite) number for the project area as specified at the pre-bid showing. Only surveyed acreage's through figures the Contractor and/or the State develops will be honored to alter these acreage numbers.

**PAYMENT**

Invoices must be submitted on prescribed Department of Environmental Protection, Special Reclamation Program forms and include verification. Certified contractor payrolls for operators directly involved in this project and a current workers compensation certificate must accompany each invoice for payment. Verification of wage rates may include employee interviews. Invoices shall be signed in blue ink so that it is easy to verify that document is an original.

MOBILIZATION/DEMobilIZATION shall be invoiced at fifty percent (50%) with the first invoice and the last 50% invoiced after demobilization and acceptance of the road abandonment or final invoice. Demobilization must have written approval.

SPILL CONTAINMENT AREA shall not exceed \$1,000.00 and will be payable in two payments. The first fifty percent (50%) payable with the first invoice and the remainder payable when all fuel tanks, containers and etc., are removed from the site.

Lump sum items shall be percentage payments based on work completed at time of invoice and paid upon acceptance by the Department of Environmental Protection.

Unit items shall be invoiced by specified units completed and accepted by the DEP.

ROAD ABANDONMENT shall be included in the final construction invoice.

**FAILURE TO COMPLETE ON TIME AND LIQUIDATED DAMAGES**

Time is an essential element of the Contract and it is important that the work be completed within the time specified. The cost to the Department of the administration of the Contract, including engineering, inspection and supervision, will increase as the time required to complete the work is increased.

The work performance period as specified in the contract's Notice to Proceed shall be complied with or result in liquidated damages. Such damages shall be assessed at an amount of two hundred and fifty dollars (\$250.00) per day for each and every day beyond the work performance period as specified in the Notice to Proceed. The total amount of daily charges will be deducted from any moneys due the Contractor, not as a penalty but as liquidated damages.

BUYER CB-23	PAGE 032	REQ. OR PO NO. DEP 14142
SPENDING UNIT WEST VIRGINIA DEPARTMENT OF ENVIRONMENTAL PROTECTION/SPECIAL RECLAMATION		

WV-36a STATE OF WEST VIRGINIA  
 Rev. 1/29/02 PURCHASING CONTINUATION SHEET  
 VENDOR:

**REVEGETATION AND WARRANTY**

The seeding date shall be at the discretion of the contractor once an approved seedbed has been prepared. In all cases a permanent vegetative cover capable of supporting the post-mining land use must be established. A warranty period of one (1) year shall commence upon completion and payment of the revegetation item of the contract. No payment will be made for additional seeding necessary to comply with warranty requirements. The warranty period will be extended for one (1) year from the date of the last augmented seeding done by the contractor. The performance bond and labor and materials bond shall remain in effect throughout the warranty period. The Standards for Evaluating Vegetative Cover as presented in Title 38, CSR2, Section 9 of the West Virginia Surface Mining Reclamation Regulations will apply.

Equipment for the retracking/scarification to eliminate rills and gullies shall be mobilized and utilized to produce slopes consistent with the regrading and topsoiling bid item prior to warranty reseeding. No additional payment will be made by DEP for this warranty work.

Water utilized for hydroseeding shall be free of injurious or other toxic substances harmful to plant life. The source of water is subject to the approval of the DEP contact person.

**CONTRACT NON-COMPLIANCE**

If in the opinion of the Department of Environmental Protection the contract is not in compliance with any line item specification, that portion of the project shall cease until a compliance schedule and understanding is demonstrated in writing and accepted by the Director of Division of Land Restoration.

**CONTRACT DELETIONS**

Any line item, or any portion thereof, may be deleted when determined by the project contact person that such line item, or portion thereof, is deemed unnecessary for the successful reclamation of this project. No claim for loss of anticipated profits will be considered.

**CANCELLATION**

The performance of work under contract may be terminated by the State in whole, or from time to time in part whenever the State shall determine that such termination is in the best interest of the State. Any such termination shall be effected by delivery to the Contractor of a Notice of Termination specifying the extent to which performance of work under the Contract is terminated and the date upon which such termination becomes effective.

When contracts, or any portion thereof, are terminated before completion of all items of work in the Contract, payment will be made for the actual number of units or items of work completed and accepted at the contract unit price. No claim for loss of anticipated profits will be considered. Reimbursement for organization of the work, when not otherwise included in the Contract, and moving equipment to and from the job will be considered where the volume of work completed and accepted is too small to compensate the Contractor for these expenses under the contract unit prices, the intent being that an equitable settlement will be made with the Contractor.

Termination of the Contract or a portion thereof shall not relieve the Contractor of his responsibilities for the completed work, nor shall it relieve his surety of its obligation for and concerning any just claims arising out of the work performed.

This contract may be cancelled in whole or in part in writing by the Director of Purchasing, without prejudice to any other right or remedy it may have, provided that the contractor is given not less than thirty (30) calendar days written notice, (delivered by certified mail, return receipt requested) of intent to terminate. This contract objective is to comply with the reclamation laws of this state and must be expedient to meet the time requirements for reclamation of revoked surface mine permits.

BUYER CB-23	PAGE 033	REQ. OR PO NO. DEP 14142
SPENDING UNIT		
WEST VIRGINIA DEPARTMENT OF ENVIRONMENTAL PROTECTION/SPECIAL RECLAMATION		

WV-36a STATE OF WEST VIRGINIA  
 Rev. 1/29/02 PURCHASING CONTINUATION SHEET  
 VENDOR:

S

Attn:

A

Re: Notice to Proceed  
 Permit Name: \_\_\_\_\_  
 Permit No. \_\_\_\_\_  
 Purchase Order No.: DEP

Dear :

M

The purpose of this letter is to express our appreciation for your work in advance and to recognize a reclamation partnership project. The official starting date for the above mentioned purchase order is . The work performance period must be completed by . The contract life of one year is provided to accomplish all line items and to process all payments within that period.

You must schedule a pre-construction conference on site within ten (10) days after receiving this notice to proceed. It is then mandatory that construction begins within ten (10) days of the pre-construction conference and continues diligently until completion of the project. Please contact this office to schedule the pre-construction conference. The foreman, superintendent, or on-the-ground supervisor must be in attendance at this conference.

Failure to comply with this notice to proceed will cause termination of the contract and forfeiture of your performance bond.

If you have any questions please feel free to contact this office.

L

Sincerely,

E

BUYER CB-23	PAGE 034	REQ. OR PO NO. DEP 14142
SPENDING UNIT WEST VIRGINIA DEPARTMENT OF ENVIRONMENTAL PROTECTION/SPECIAL RECLAMATION		

WV-36a                      STATE OF WEST VIRGINIA  
Rev. 1/29/02              PURCHASING CONTINUATION SHEET  
VENDOR:

---

## General Requirements

### Project Construction Sign

#### Work Required

The work to be performed under this Section consists of providing all labor, material and equipment necessary to install a project sign as indicated on the detail included herein and as specified herein.

#### Materials

- (a) Paint. Paint for the project sign shall be one (1) coat Exterior-Grade Wood Primer- Sealer, and two (2) coats Exterior-Grade Enamel by Glidden or equivalent.
- (b) Wood. Sign face shall be 3/4" X 4' X 8' Marine Exterior plywood, and posts and cross braces shall be treated.
- (c) Hardware. All hardware shall be manufactured from good, commercial-quality material and be rust resistant such as galvanized coated.

#### Execution

- (a) Project Sign. The signboard shall be cut to the dimensions shown on the details herein. The sign shall be painted with one (1) coat of primer and two (2) coats of white enamel. All exterior cut edges shall be smooth sanded prior to painting. All edges shall be double primed. The letters, border and strips shall be painted as shown on the detail drawing.

The Contractor shall bolt the sign to posts and provide required cross bracing. The posts and sign shall be erected and posts set in gravel base, as shown on the drawings. One (1) sign is required and is to be located at the direction of WVDEP.

- (b) Payment. Payment for the work which shall include installation of the project sign shall be incidental to the lump sum bid item for "Mobilization/Demobilization"

Note: No construction work shall commence prior to the project sign being installed.



Joe Manchin, III  
Governor



Stephanie Timmermeyer,  
Cabinet Secretary



Ken Ellison,  
Director

STATE OF WEST VIRGINIA  
DEPARTMENT OF ENVIRONMENTAL PROTECTION

Division of Land Restoration  
Office of Special Reclamation

Project Cost: \$XXXX,XXX.00  
Funding provided by the Special Reclamation Coal Tax paid by WV Coal Mine Companies

Permit Name  
Permit Number

Contractor: Joe Smith Contracting

Project Start Date: 01/01/01

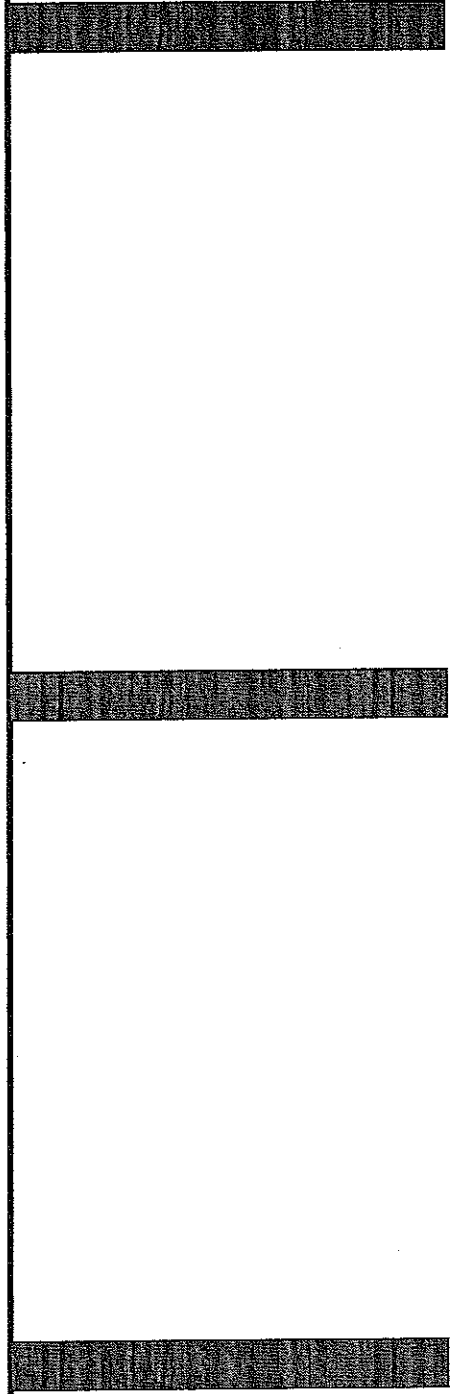

1 1/8" 17 1/4" 77 1/4" 27 3/4" 18" 2 1/4"

STATE OF WEST VIRGINIA  
DEPARTMENT OF ENVIRONMENTAL PROTECTION



Division of Land Restoration  
Office of Special Reclamation

Joe Manchin, III  
Governor

Project Cost: \$XXX,XXX.00  
Funding provided by the Special Reclamation Coal Tax paid by WV Coal Mine Companies



Stephanie Timmermeyer,  
Cabinet Secretary



Ken Ellison,  
Director

Permit Name  
Permit Number  
Contractor: Joe Smith Contracting  
Project Start Date: 01/01/01

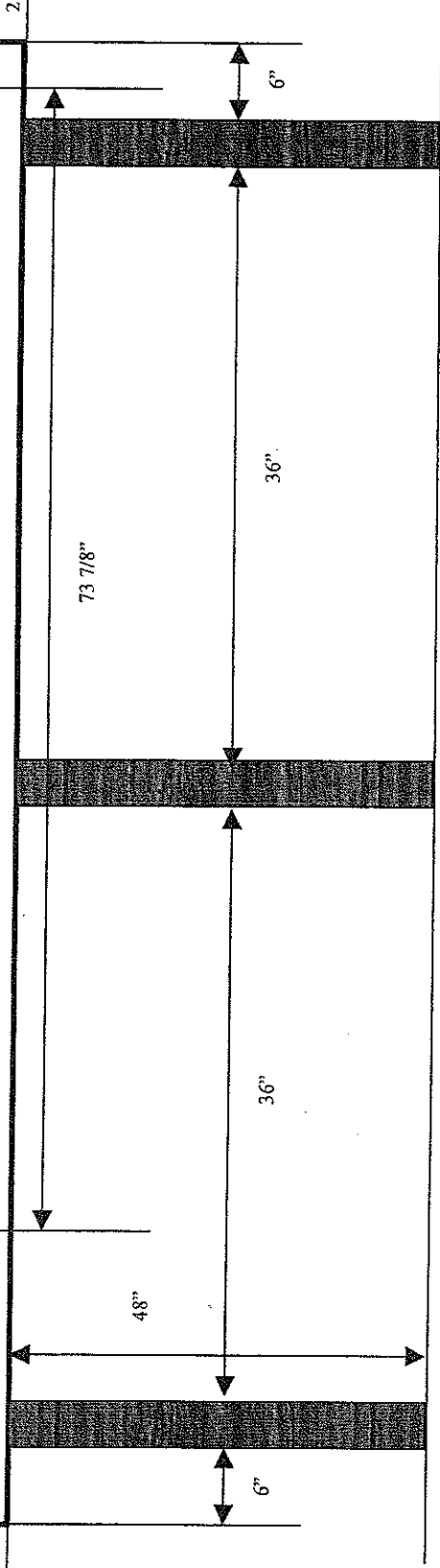

96"



STATE OF WEST VIRGINIA  
DEPARTMENT OF ENVIRONMENTAL PROTECTION

Division of Land Restoration  
Office of Special Reclamation

Joe Manchin, III  
Governor

48"



Stephanie Timmermeyer,  
Cabinet Secretary



Ken Ellison,  
Director

Project Cost: \$XXX,XXX.00  
Funding provided by the Special Reclamation Coal Tax paid by WV Coal Mine Companies

Permit Name  
Permit Number

Contractor: Joe Smith Contracting

Project Start Date: 01/01/01

5 1/4"

7 7/8"

9 3/8"

81 3/8"

6" 2 1/4" 1 1/4" 2 1/4" 3 3/4" 2 1/4" 1 1/4" 2 1/4" 3 3/4" 1 1/4" 4 7/8" 2 1/4" 1 1/4" 2 1/4" 4 7/8" 1 1/4" 3 3/4"

**STATE OF WEST VIRGINIA**  
**DEPARTMENT OF ENVIRONMENTAL PROTECTION**

**Division of Land Restoration**  
**Office of Special Reclamation**

Project Cost: \$XXXX,XXX.00  
 Funding provided by the Special Reclamation Coal Tax paid by WV Coal Mine Companies

Permit Name  
 Permit Number

Contractor: Joe Smith Contracting  
 Project Start Date: 01/01/01

17 1/4" 1 1/2" 3/4" 1 1/2" 9 1/2" 1" 3/4" 1" 8" 1" 3/4" 1" 3 3/4"

  
 Joe Manchin, III  
 Governor

  
 Stephanie Timmermeyer,  
 Cabinet Secretary

  
 Ken Ellison,  
 Director





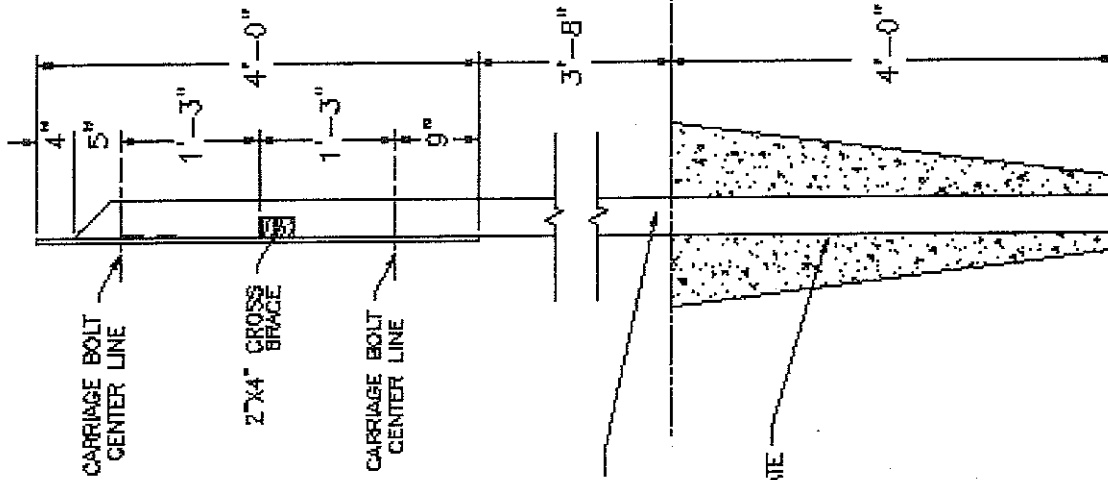

- NOTES:**
- 1.) SIGN BOARD TO BE 3/4" x 4' x 8' MARINE PLYWOOD.
  - 2.) SIGN BOARD COLOR IS WHITE AND LETTER COLORS ARE DARK GREEN.
  - 3.) TREATED 2" x 4" CROSS BRACE LET INTO POSTS.
  - 4.) MOUNT SIGN TO POSTS USING 3/8" x 5" GALVANIZED CARRIAGE BOLTS.
  - 5.) USE 4" x 4" x 12' TREATED POSTS.
  - 6.) LOCATION DETERMINED BY WVDEP.

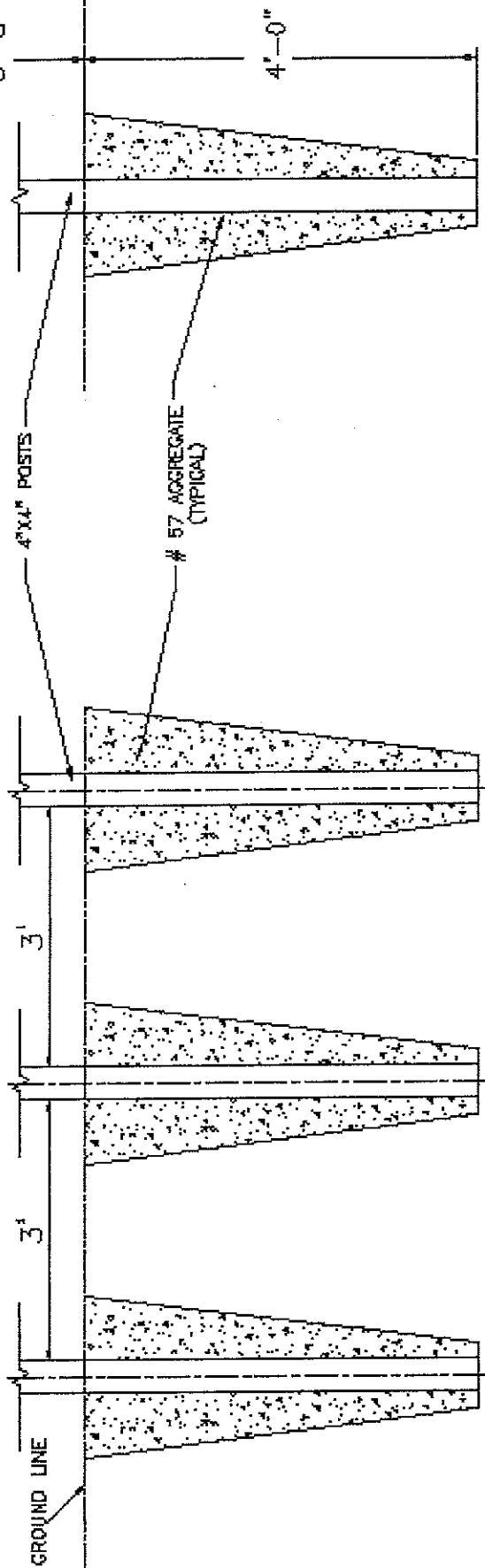

PROJECT SIGN  
NOT TO SCALE

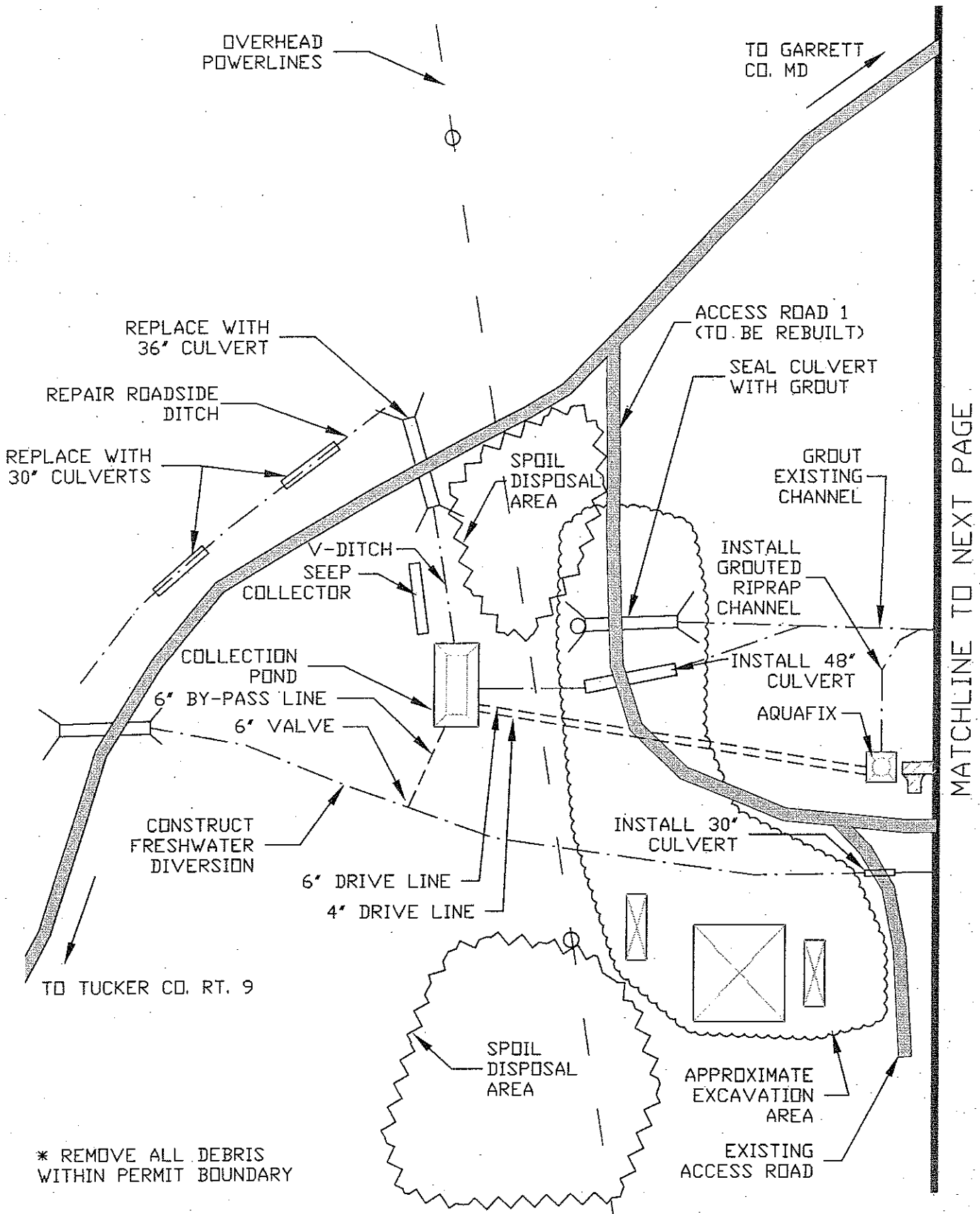

MATCHLINE TO NEXT PAGE

\* REMOVE ALL DEBRIS WITHIN PERMIT BOUNDARY

BUFFALO COAL #S-122-80  
SITE PLAN

TO GARRETT  
CO. MD

EXISTING  
CHANNEL

UPGRADE EXISTING POND

SPILLWAY PIPE  
AND CHANNEL

GROUT  
EXISTING  
CHANNEL

6" SLUDGE LINE

EXISTING ROAD

NEW ACCESS  
ROAD 1A

INSTALL 12" HDPE PIPE

MATCHLINE TO PREVIOUS PAGE

CONSTRUCT  
FRESHWATER  
DIVERSION

INSTALL 30"  
CULVERT

PROPOSED  
SLUDGE CELL

EXISTING  
SLUDGE  
CELL

\* REMOVE ALL DEBRIS  
WITHIN PERMIT BOUNDARY

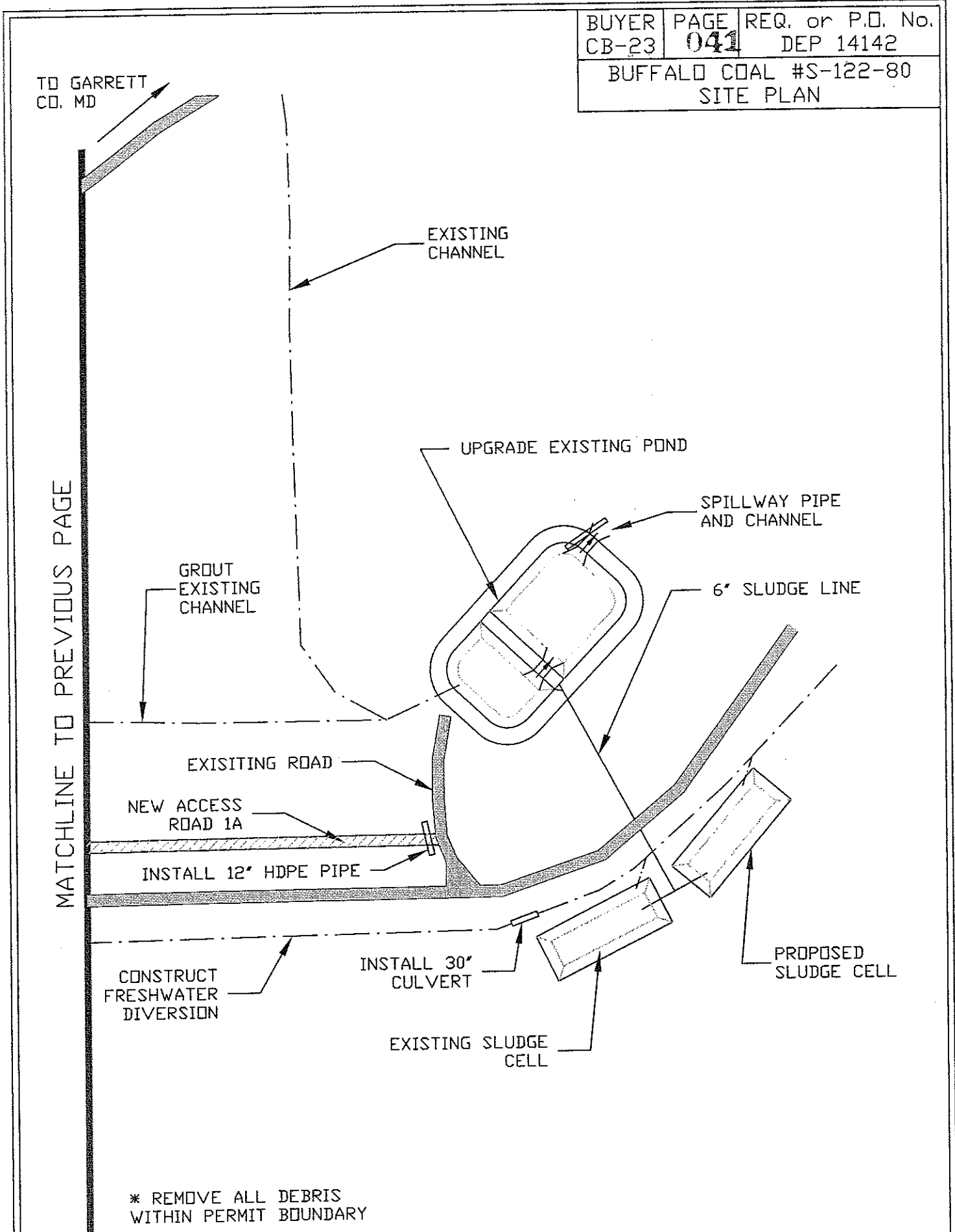

NEW ACCESS ROAD

NEW ACCESS ROAD

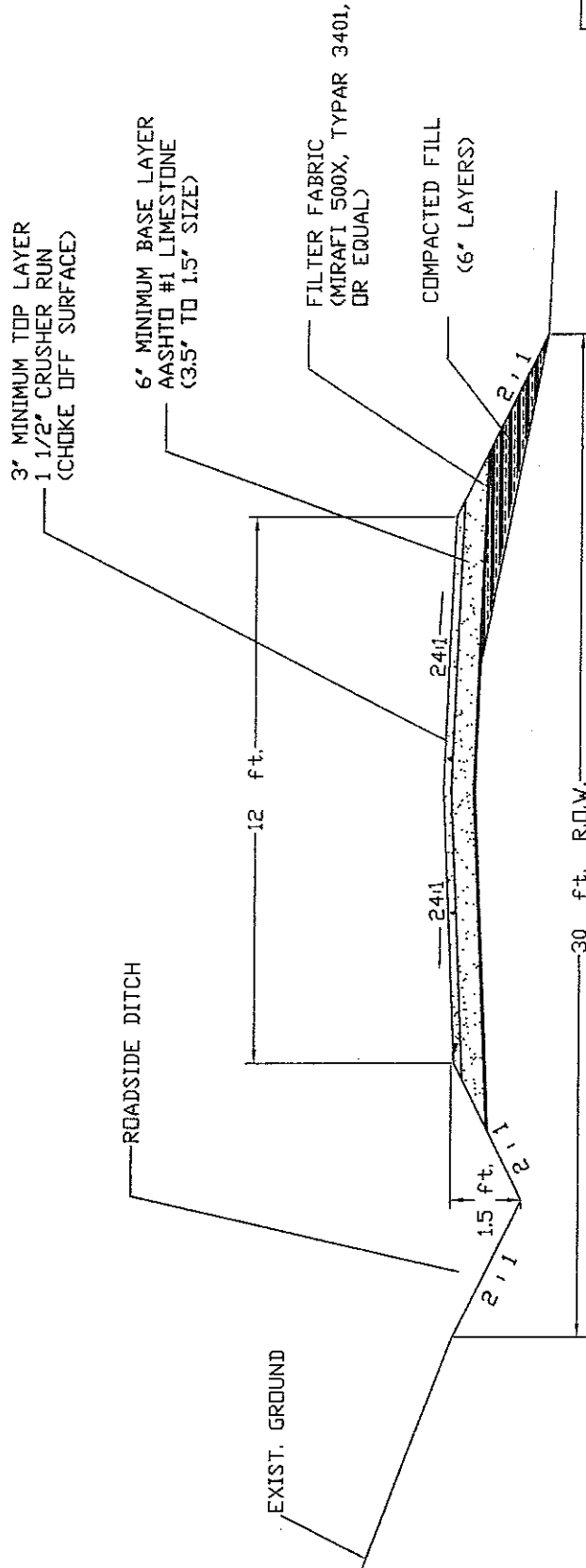

TYPICAL SECTION

- NOTES:
- ANY TREES OR BRUSH WITHIN THE 30 FEET R.O.W. OF THE ROAD SHALL BE REMOVED.
  - ANY OVERHANGING TREE LIMBS IN THE R.O.W. AT A HEIGHT OF 15 FEET OR LESS SHALL BE REMOVED.

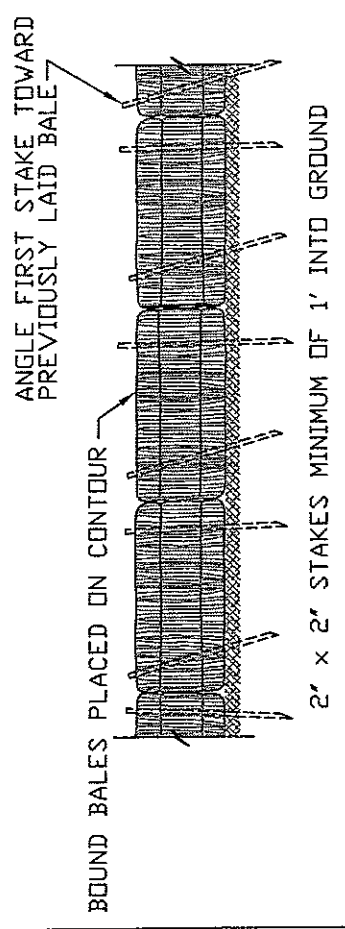

ANCHORING DETAIL

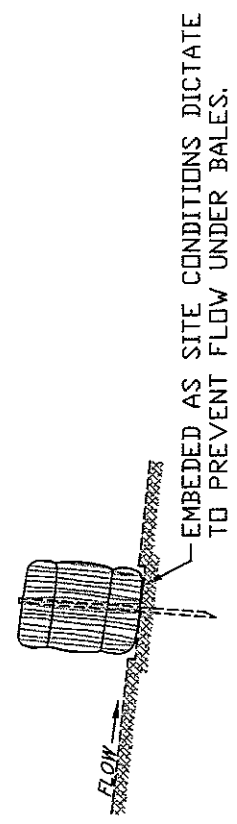

END VIEW

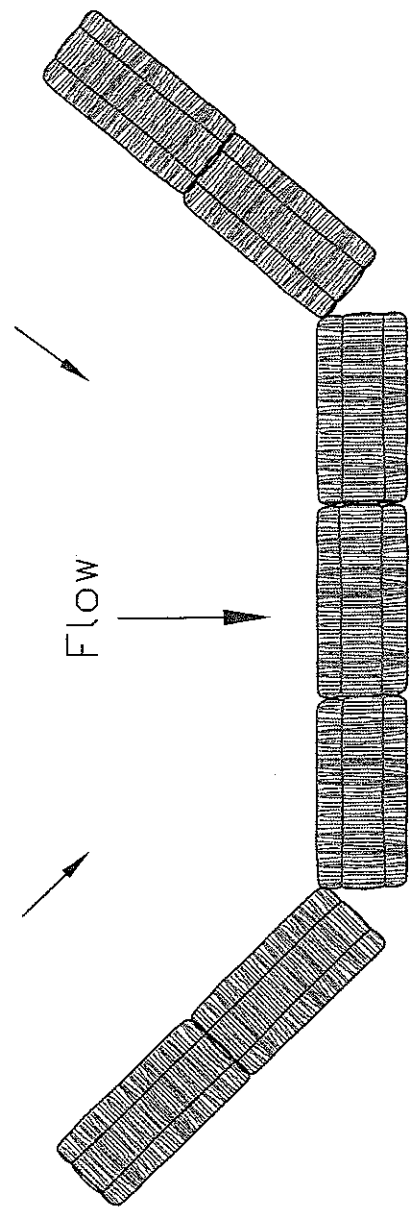

DESIGN TO FIT SITE CONDITIONS

SEDIMENT BARRIER  
TOP VIEW

NOT TO SCALE

# FRESH WATER COLLECTION POND

BUYER	PAGE	REQ. or P.O. No.
CB-23	044	DEP 14142

## COLLECTION POND

TOP VIEW

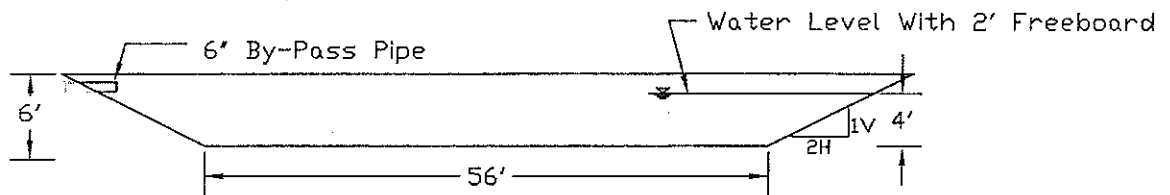
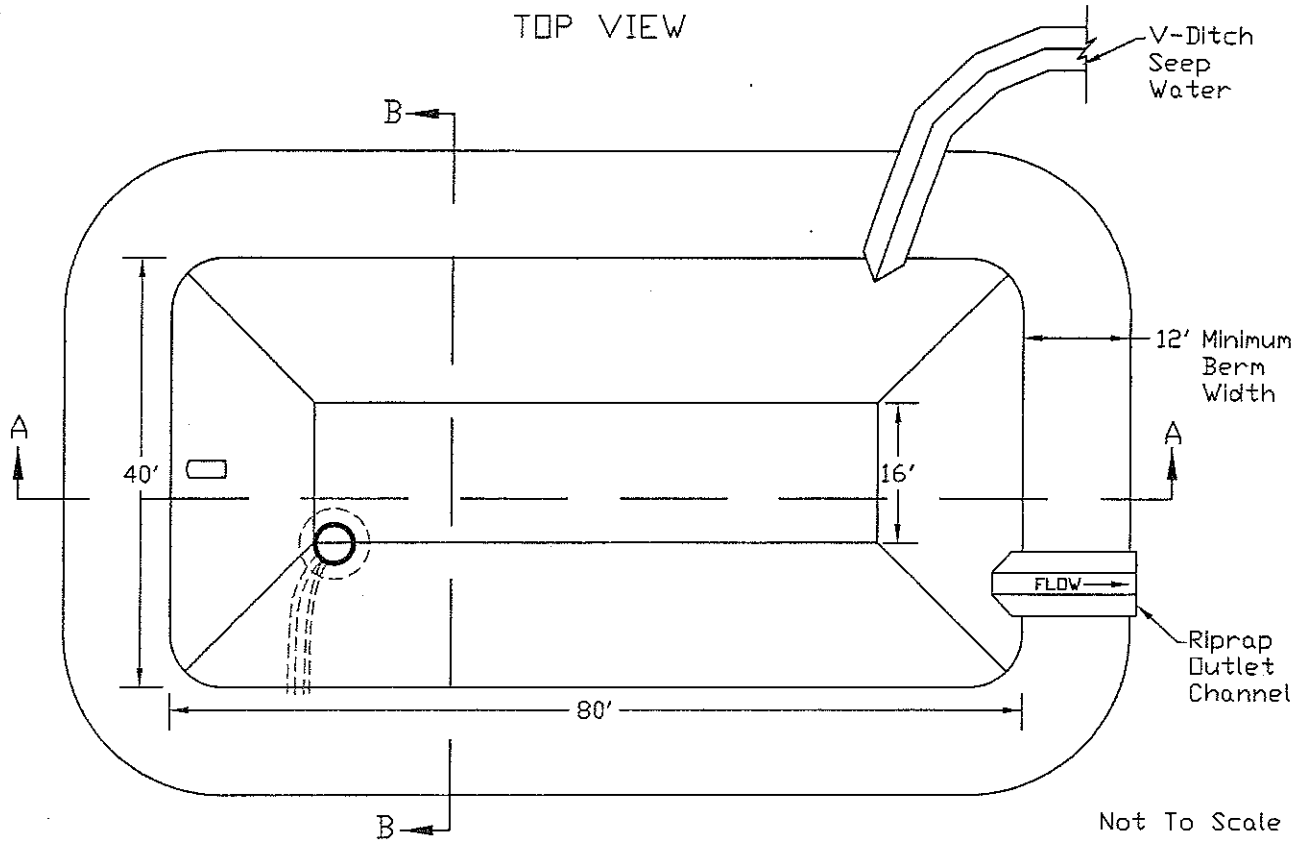

SECTION A-A

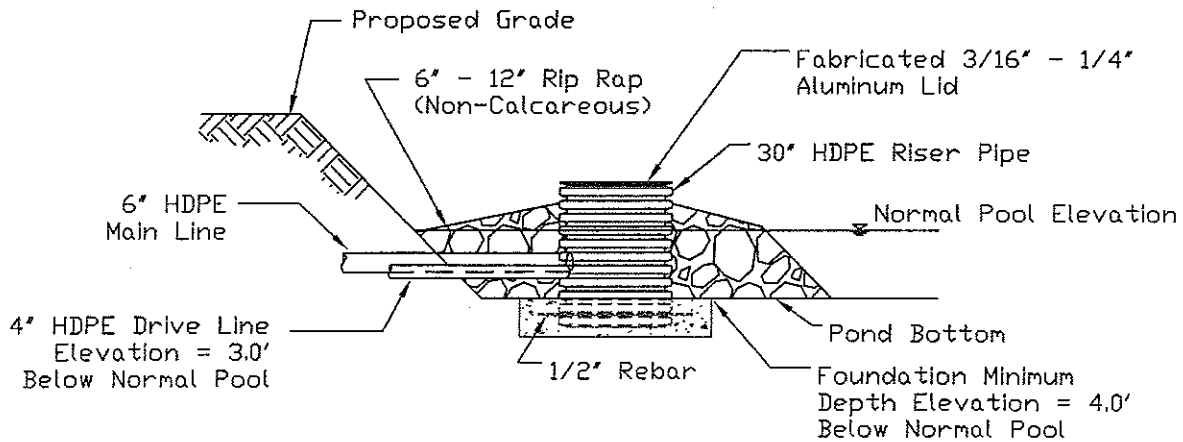

SECTION B-B

RISER WATER INTAKE

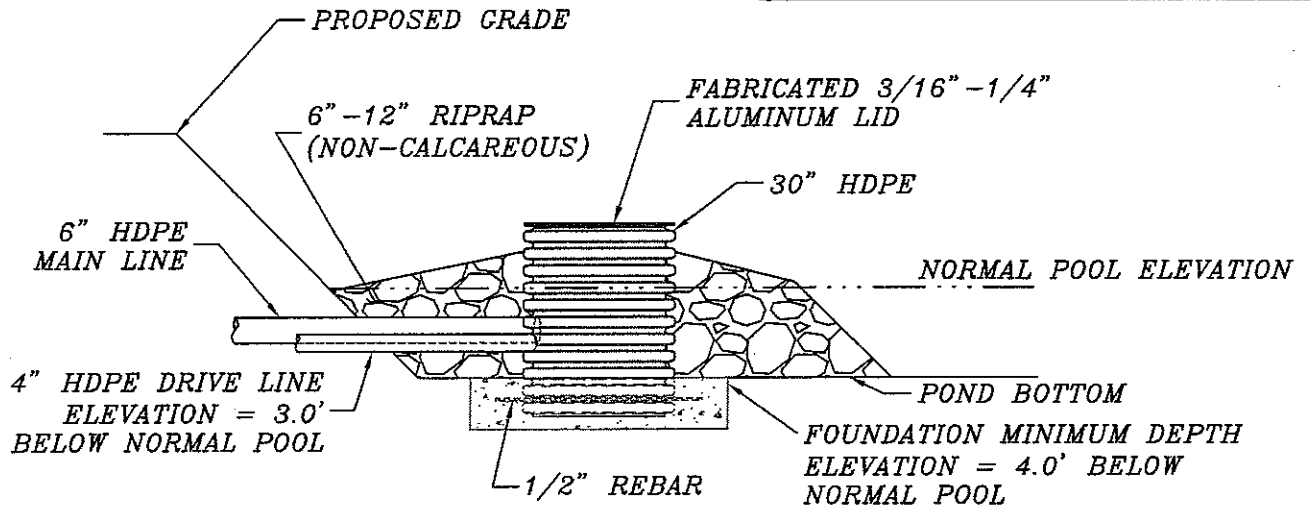

NOTE: DEPTH MAY VARY  
 BASED ON SUITABLE  
 FOUNDATION MATERIAL.

SECTION A'-A'

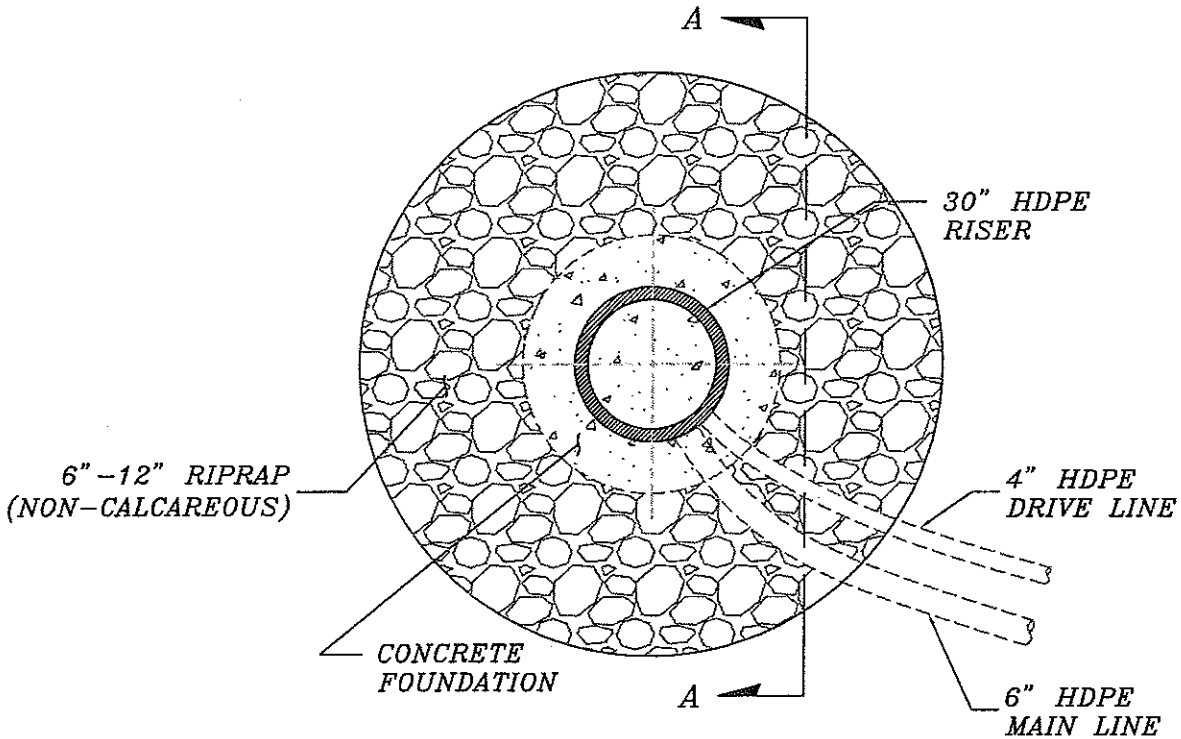

NOT TO SCALE

RISER INTAKE  
FOUNDATION PLAN

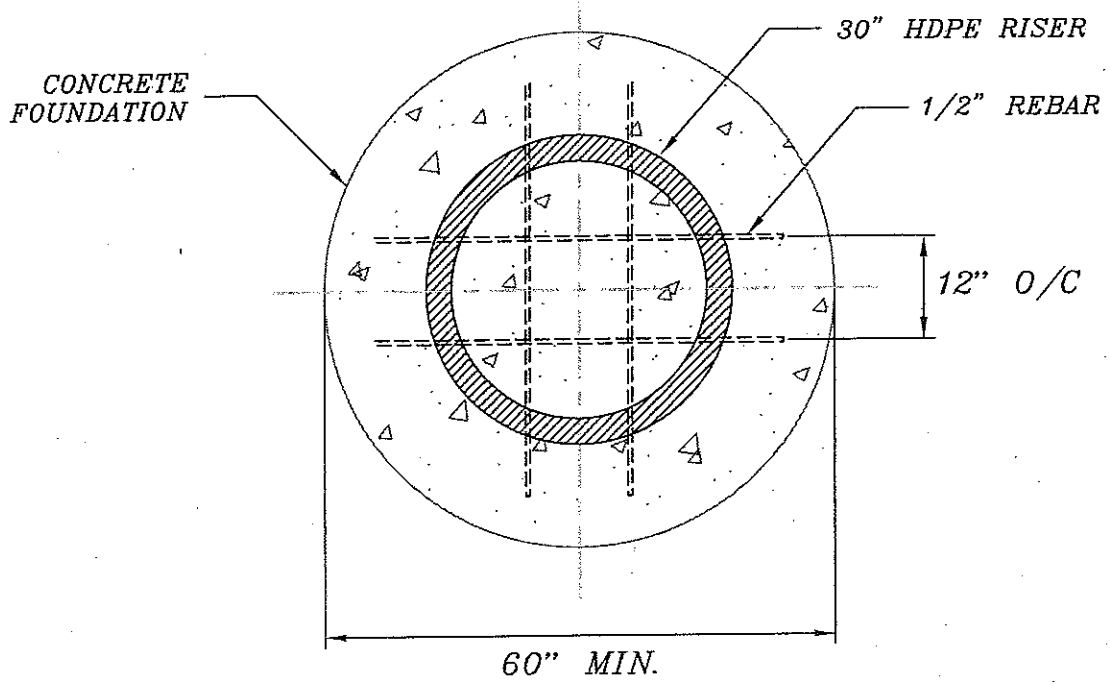
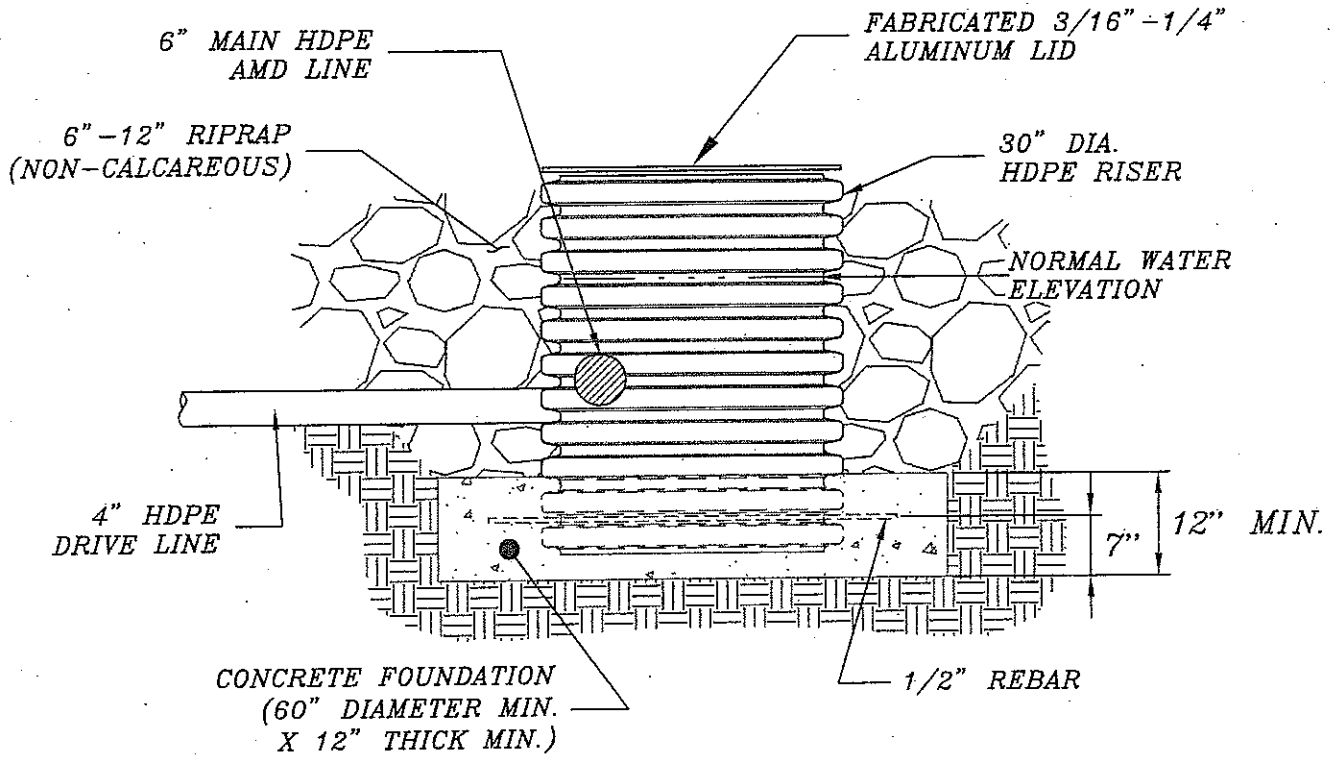



RISER PERFORATIONS

30" HDPE RISER  
HOLE SPACING

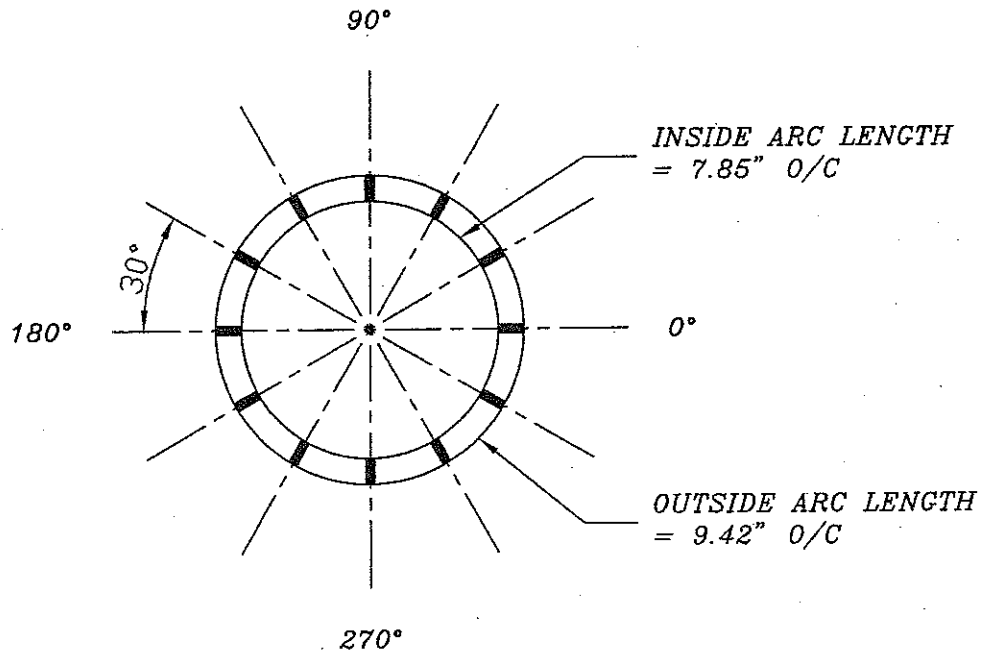

12 - 1" DIAMETER HOLES PER ROW  
5 ROWS MINIMUM  
(PERFORATE ENTIRE HEIGHT OF RISER)

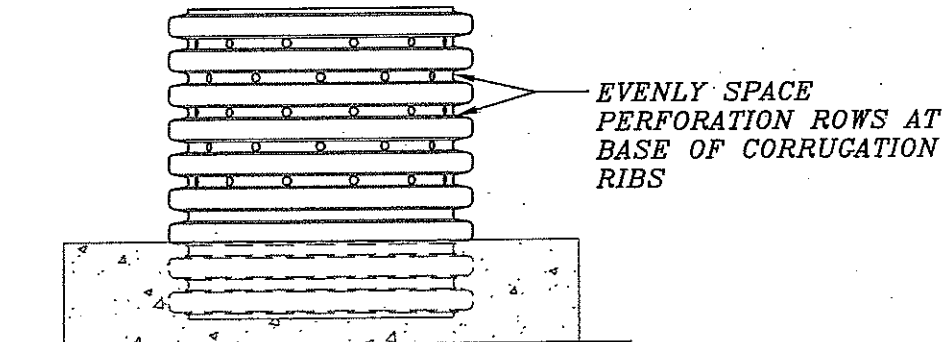

NOTE: HEIGHT OF RISER  
MAY VARY BASED ON DEPTH  
OF CONCRETE FOUNDATION

FOUNDATION DETAILS

18" BY 18" STAINLESS STEEL BEARING PLATES WELDED TO THE SILD POSTS

3 MATS OF #5 REBAR ON A 6" X 6" GRID.

BACKFILL TO TOP OF CONCRETE PAD WITH COHESIVE SOILS COMPACTED IN 8" LIFTS.

4 - 1" DIAMETER STAINLESS STEEL ANCHOR BOLTS EXTENDED BELOW THE UPPER REBAR MAT.

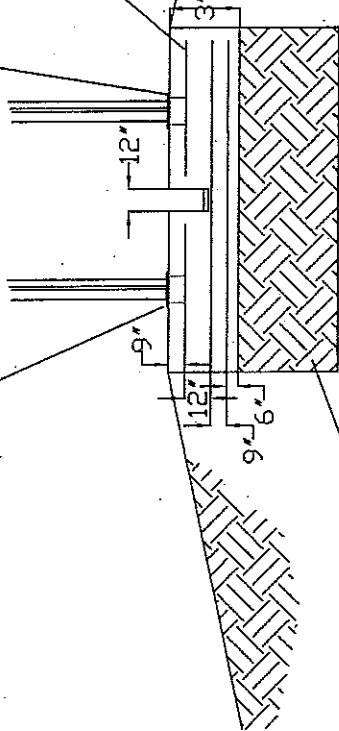

EXCAVATE TO CONSOLIDATED MATERIAL AND COMPACT WITH 3/4" CRUSHER RUN LIMESTONE IN 6" LIFTS USING A HAND DIRECTED TAMPER UNTIL THE DESIGN ELEVATION IS ACHIEVED.

CROSS - SECTION B-B'

MOUNTING PLATE DETAILS

ANCHOR BOLTS ARE SPACED 15" APART MEASURED FROM CENTER TO CENTER.  
 STAINLESS STEEL PLATES ARE 18" BY 18" BY 1" THICK  
 HOLES ARE 1 1/8" IN DIAMETER.  
 ANCHOR BOLT SPACING TEMPLATE TO BE PROVIDED BY LIME SILD MANUFACTURER.

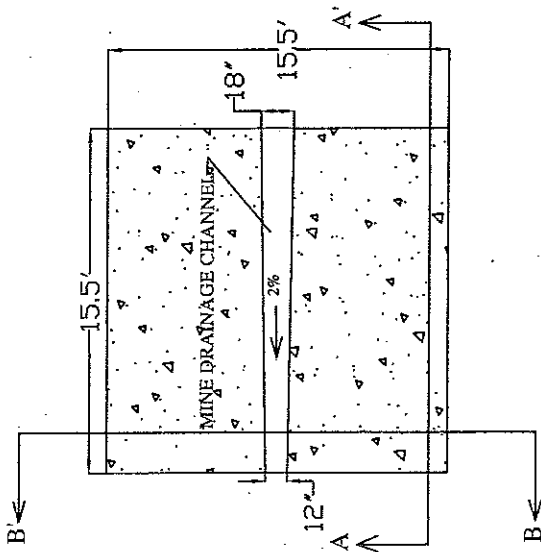

PLAN VIEW

DIRECTION OF WATER FLOW

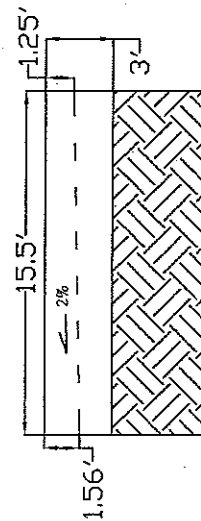

CROSS - SECTION A-A'

DRIVE LINE SCHEMATIC

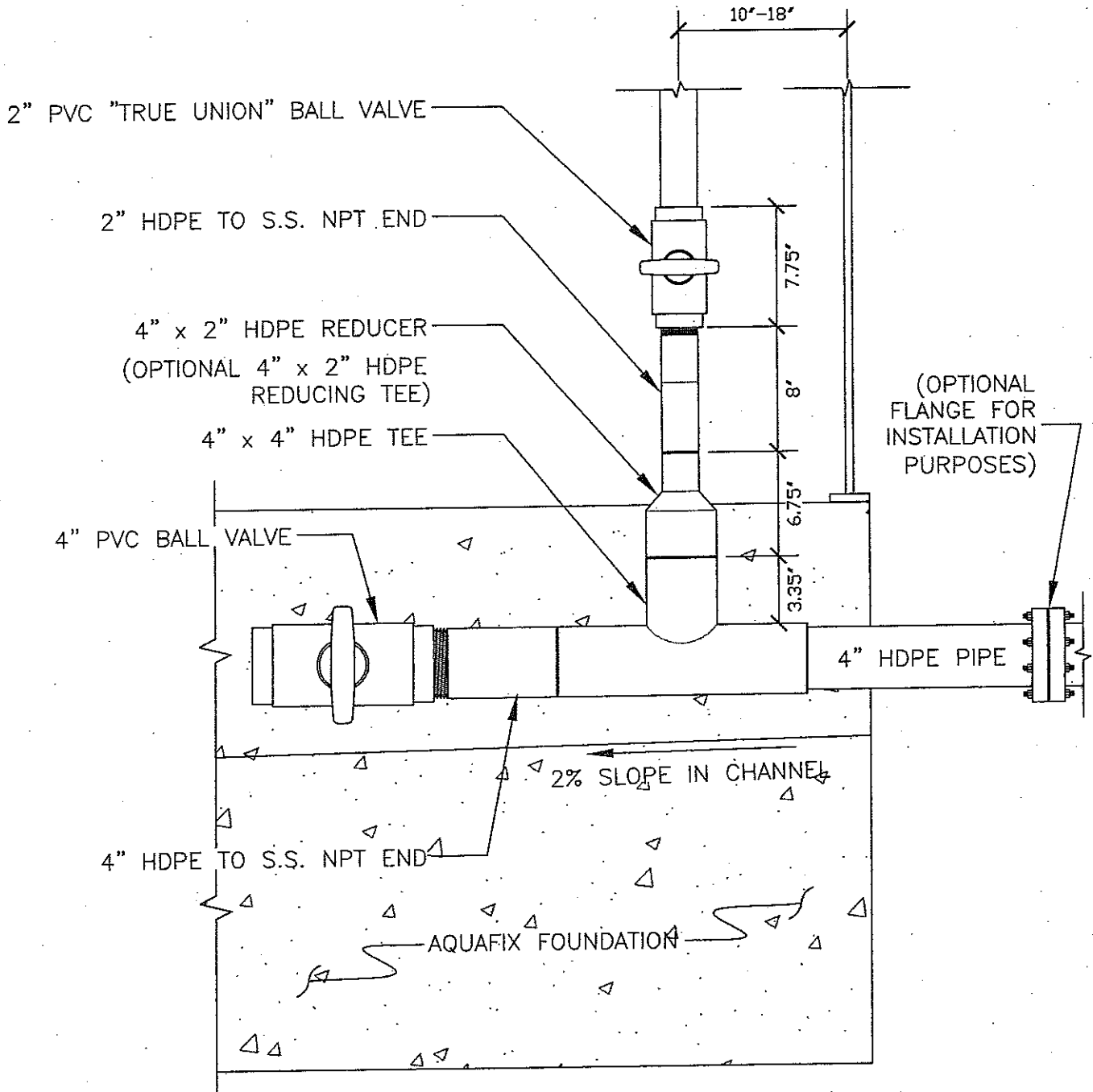

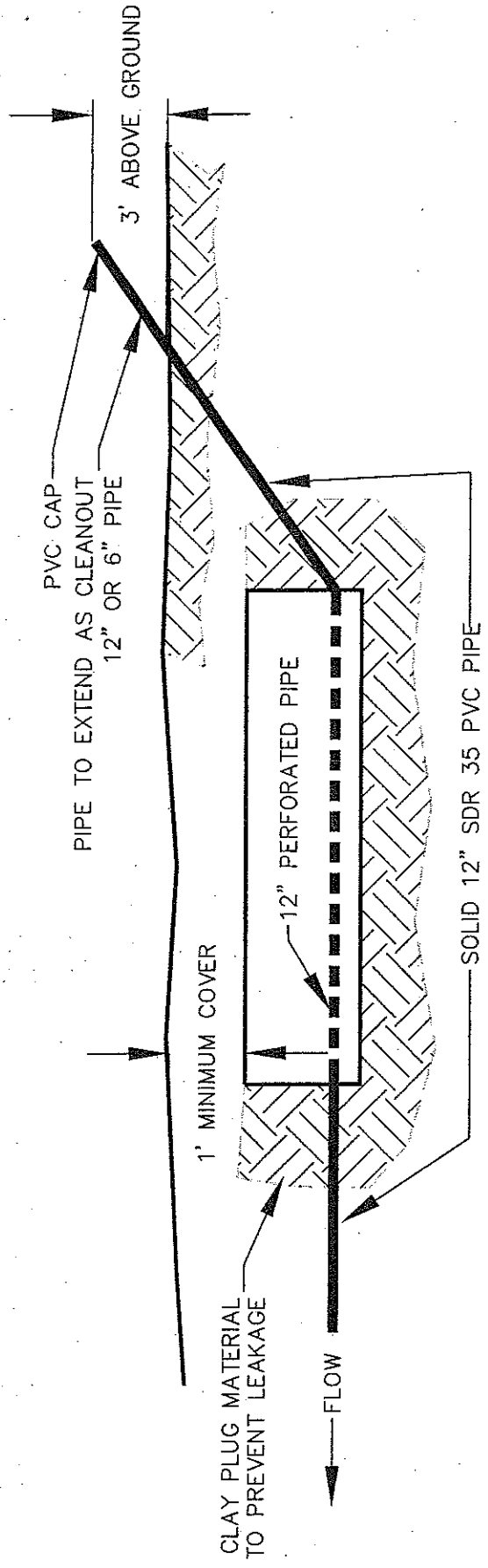

SIDE VIEW

NOT TO SCALE

WRAP WITH FILTER FABRIC (NONWOVEN)  
TYPAR 3401 or EQUIVALENT

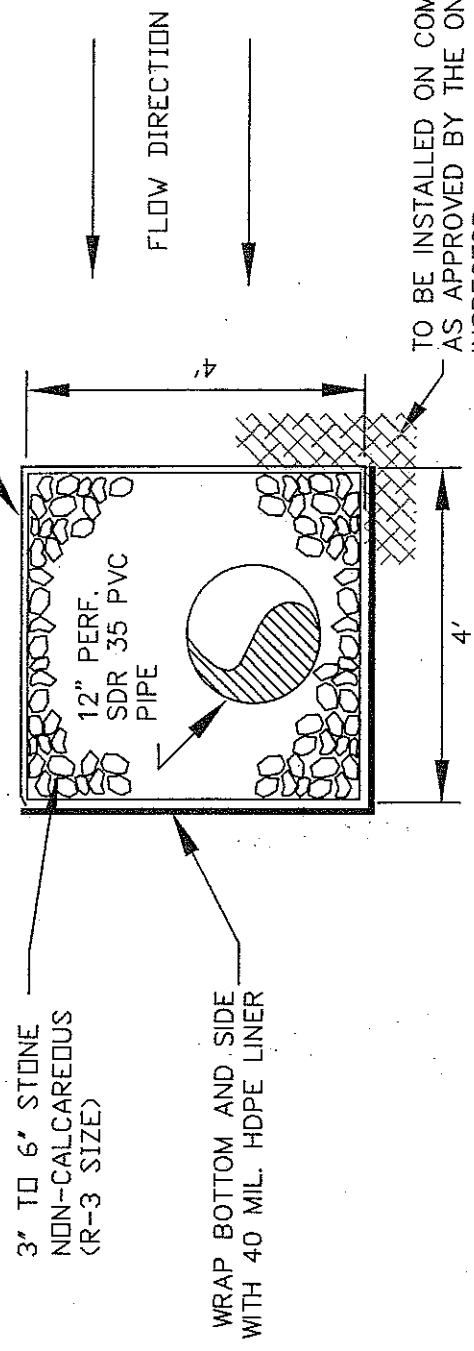

END VIEW

TO BE INSTALLED ON COMPETENT MATERIAL  
AS APPROVED BY THE ON-SITE DEP  
INSPECTOR.

# TRAPEZOIDAL CHANNEL & DIVERSION DITCH

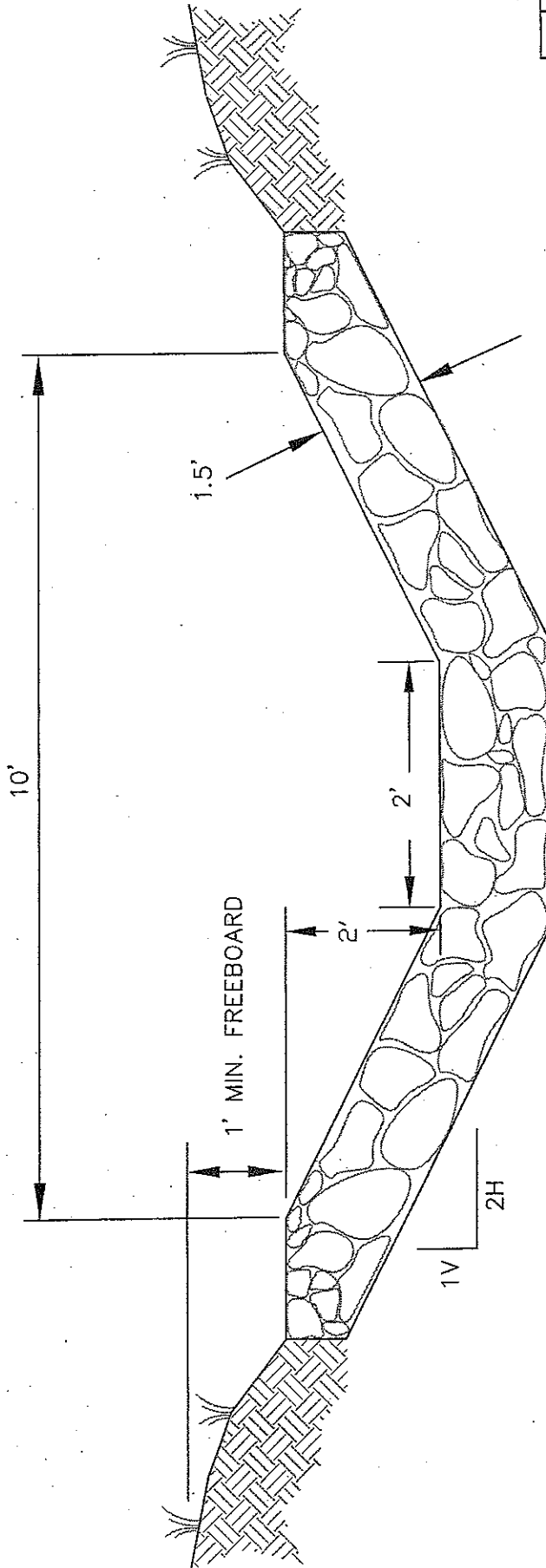

BUYER CB-23	PAGE 051	REQ. or P.O. No. DEP. 14142
TRAPEZOIDAL - DITCH		

NOT TO SCALE

PAYMENT SHALL BE FOR ACTUAL LENGTH OF DITCH CONSTRUCTED.

R-5 LIMESTONE RIPRAP (STANDARD) UNLESS OTHERWISE NOTED, RIPRAP SHALL BE DURABLE ROCK PLACED IN A 1.5 FOOT BLANKET. TWENTY-FIVE (25%) OF THE ROCK WILL BE OF 18 INCHES OR LARGER, THE REMAINING SEVENTY-FIVE (75%) SHALL BE WELL GRADED MATERIAL (MINIMUM 3 INCHES TO MAXIMUM 15 INCHES) OF SUFFICIENT ROCK SMALL ENOUGH TO FILL THE VOIDS BETWEEN THE LARGER ROCK. SHALE SHALL NOT BE USED FOR RIPRAP, IF RIPRAP STABILITY IS QUESTIONABLE, DURABILITY SHALL BE DETERMINED BY THE SODIUM SULPHATE TEST ASTM C 88/AASHTO T 104-77.

# V - DITCH

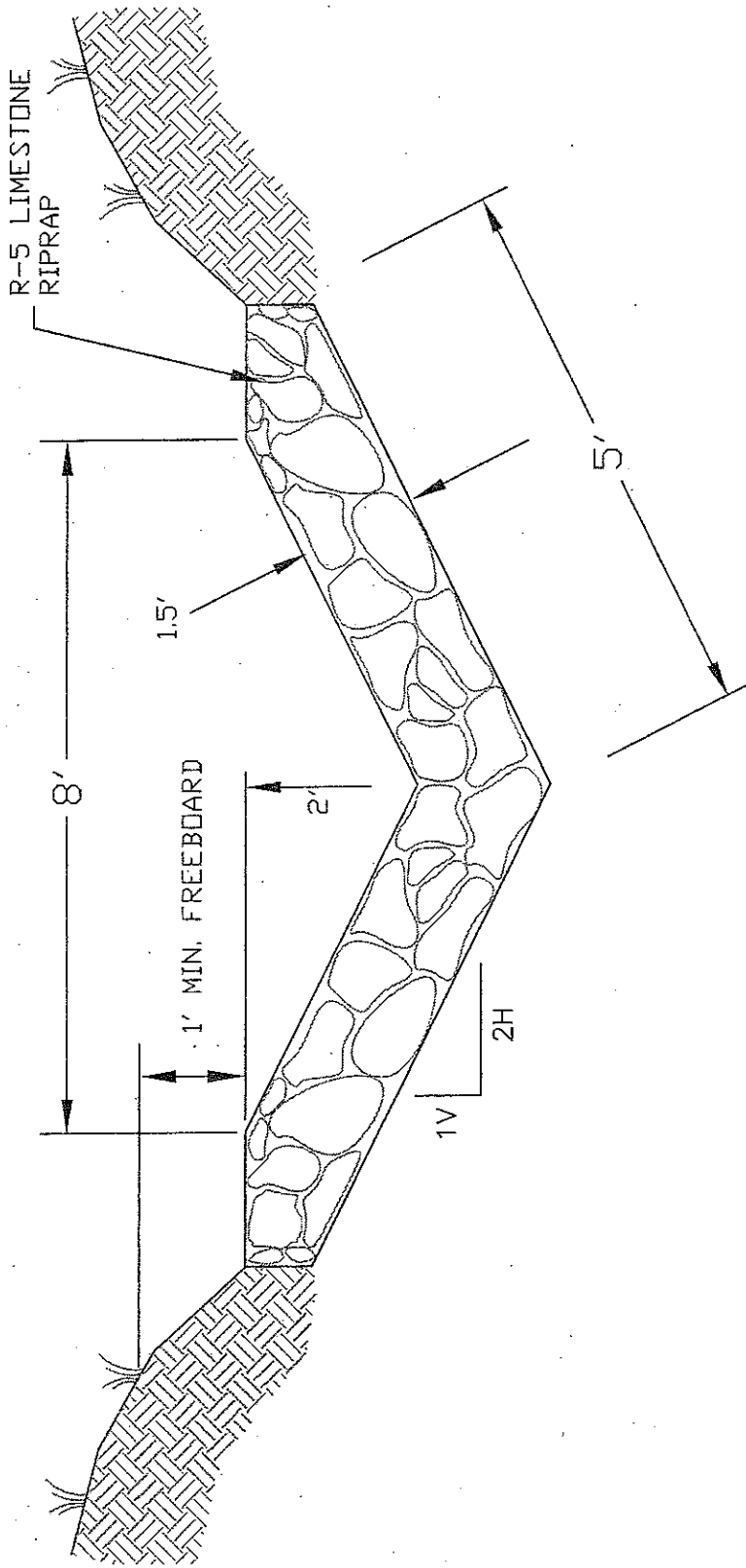

NOT TO SCALE

PAYMENT SHALL BE FOR ACTUAL LENGTH OF DITCH CONSTRUCTED.

R-5 LIMESTONE RIPRAP (STANDARD) UNLESS OTHERWISE NOTED, RIPRAP SHALL BE DURABLE ROCK PLACED IN A 1.5 FOOT BLANKET. TWENTY-FIVE (25%) OF THE ROCK WILL BE OF 18 INCHES OR LARGER, THE REMAINING SEVENTY-FIVE (75%) SHALL BE WELL GRADED MATERIAL (MINIMUM 3 INCHES TO MAXIMUM 15 INCHES) OF SUFFICIENT ROCK SMALL ENOUGH TO FILL THE VOIDS BETWEEN THE LARGER ROCK. SHALE SHALL NOT BE USED FOR RIPRAP. IF RIPRAP STABILITY IS QUESTIONABLE, DURABILITY SHALL BE DETERMINED BY THE SODIUM SULPHATE TEST ASTM C 88/AASHTO T 104-77.

V - DITCH 8' WIDE

# GROUTED RIPRAP DITCH

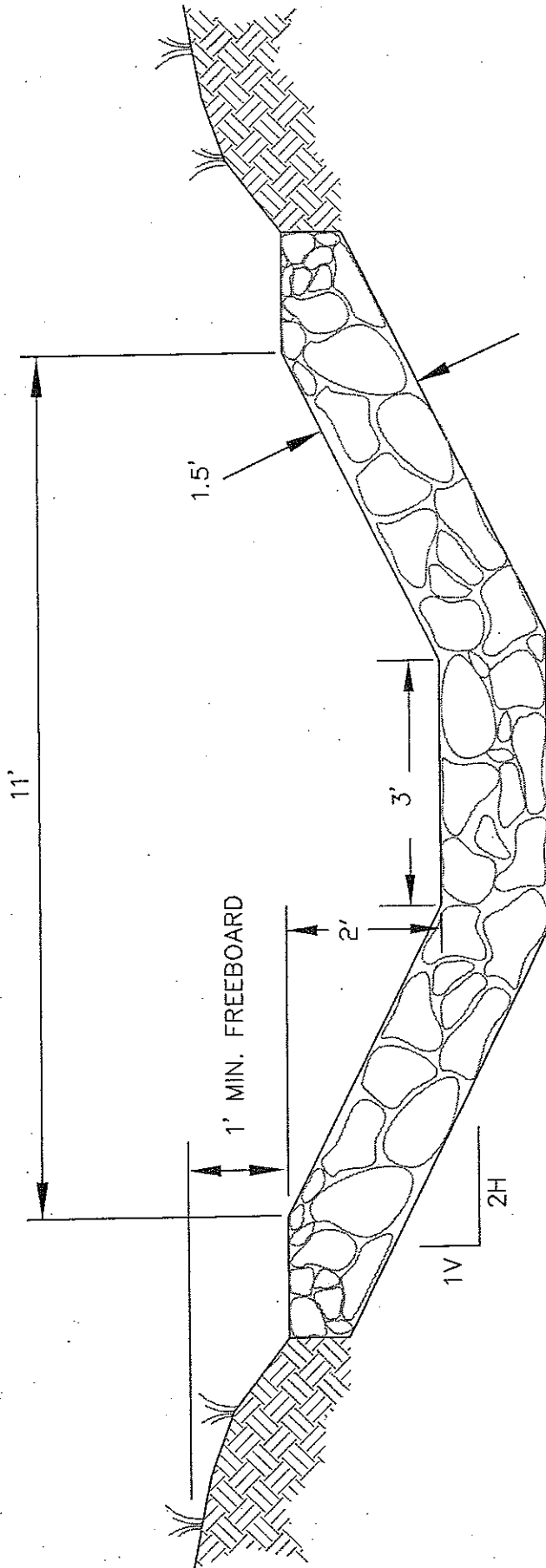

USE ONE PART OF TYPE II (SULPHATE RESISTANT) PORTLAND CEMENT AND 3 PARTS SAND, ADD WATER TO MAKE GROUT. THOROUGHLY WORK GROUT INTO VOID SPACES, AND BRUSH EXCESS GROUT OFF TOP OF RIPRAP STONES.

NOT TO SCALE

PAYMENT SHALL BE FOR ACTUAL LENGTH OF DITCH CONSTRUCTED.

R-5 LIMESTONE RIPRAP (STANDARD) UNLESS OTHERWISE NOTED, RIPRAP SHALL BE DURABLE ROCK PLACED IN A 1.5 FOOT BLANKET. TWENTY-FIVE (25%) OF THE ROCK WILL BE OF 18 INCHES OR LARGER, THE REMAINING SEVENTY-FIVE (75%) SHALL BE WELL GRADED MATERIAL (MINIMUM 3 INCHES TO MAXIMUM 15 INCHES) OF SUFFICIENT ROCK SMALL ENOUGH TO FILL THE VOIDS BETWEEN THE LARGER ROCK. SHALE SHALL NOT BE USED FOR RIPRAP. IF RIPRAP STABILITY IS QUESTIONABLE, DURABILITY SHALL BE DETERMINED BY THE SODIUM SULPHATE TEST ASTM C 88/AASHTO T 104-77.

BUYER  
CB-23

PAGE  
153

REQ. or P.O. No.  
DEP 14142

GROUTED DITCH

SPILLWAY DETAIL

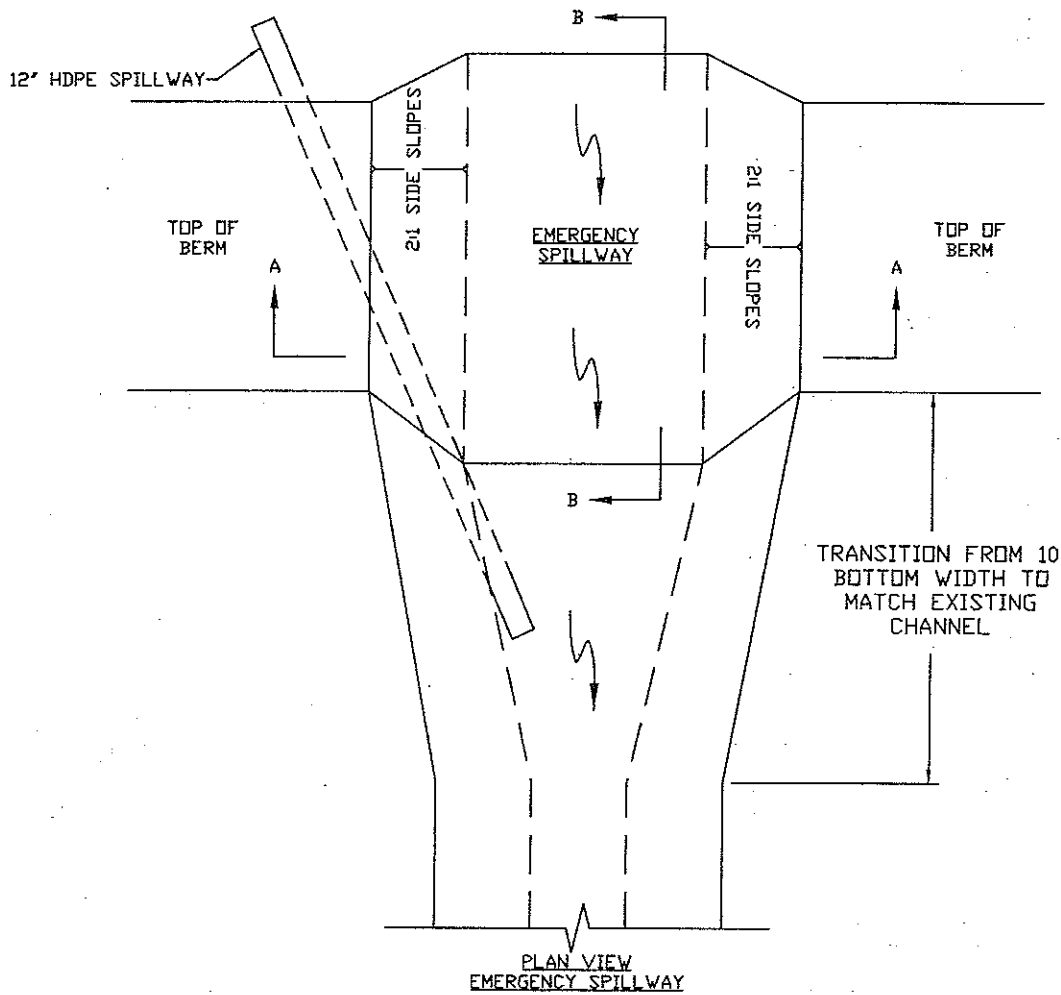
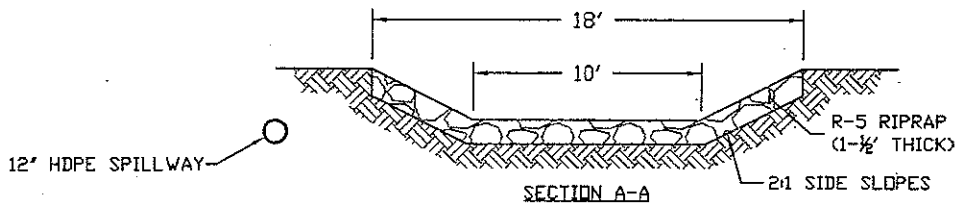
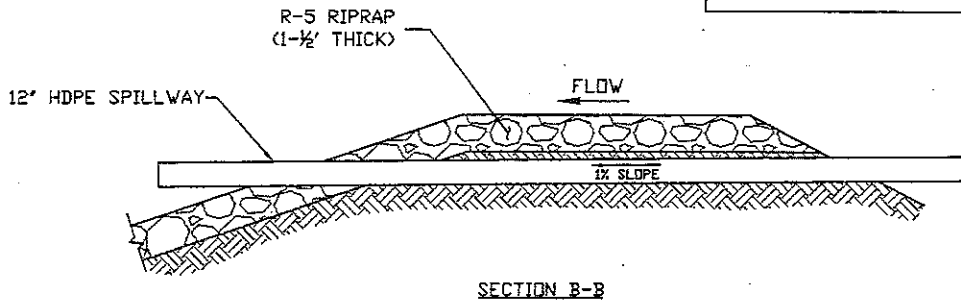



CURTAIN BAFFLE DETAIL

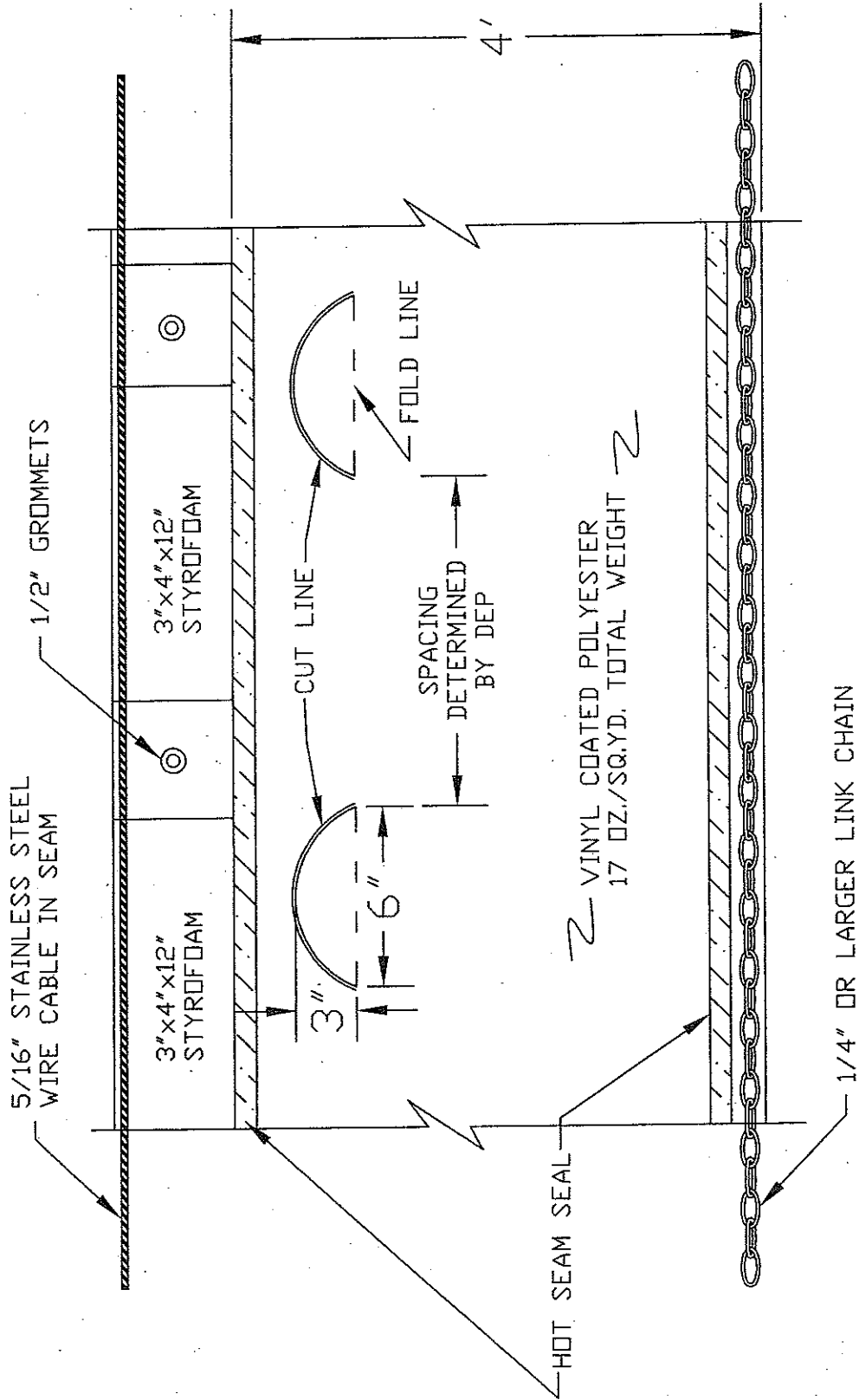

NOTE: THE CABLE MUST EXTEND 10 FEET PAST THE BAFFLE MATERIAL ON EACH END.

# PIPE PERFORATION DETAILS

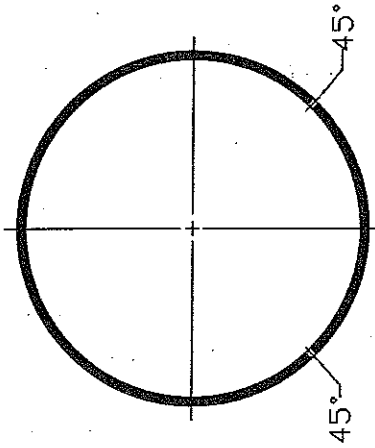

## 2, 4, & 6 INCH DIAMETER PIPE PERFORATIONS

HOLE SPACING SHALL BE 1/2 INCH DIAMETER FOR 2 & 4 INCH PIPE. USE 1 INCH DIAMETER HOLES FOR 6 INCH PIPE.

HOLE SPACING SHALL BE 4 INCHES ON CENTER ALONG THE LENGTH OF PIPE WITHIN SEEP COLLECTOR.

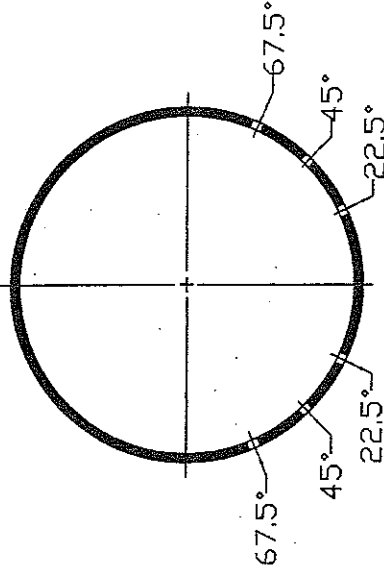

## 12 INCH DIAMETER PIPE PERFORATIONS

HOLE SPACING SHALL BE 1 INCH DIAMETER.

HOLE SPACING SHALL BE 6 INCHES ON CENTER ALONG THE LENGTH OF PIPE WITHIN SEEP COLLECTOR.

# ANIMAL GUARD DETAILS

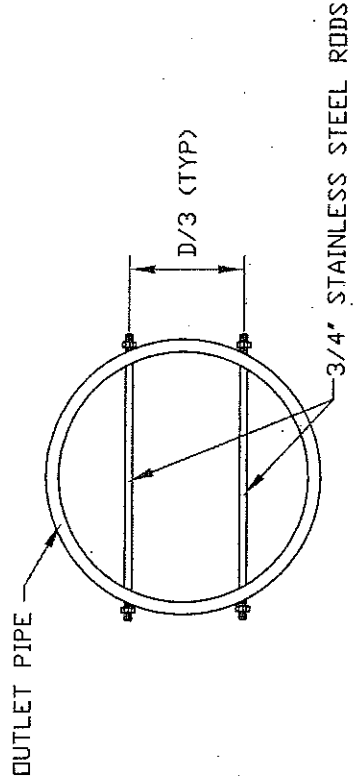

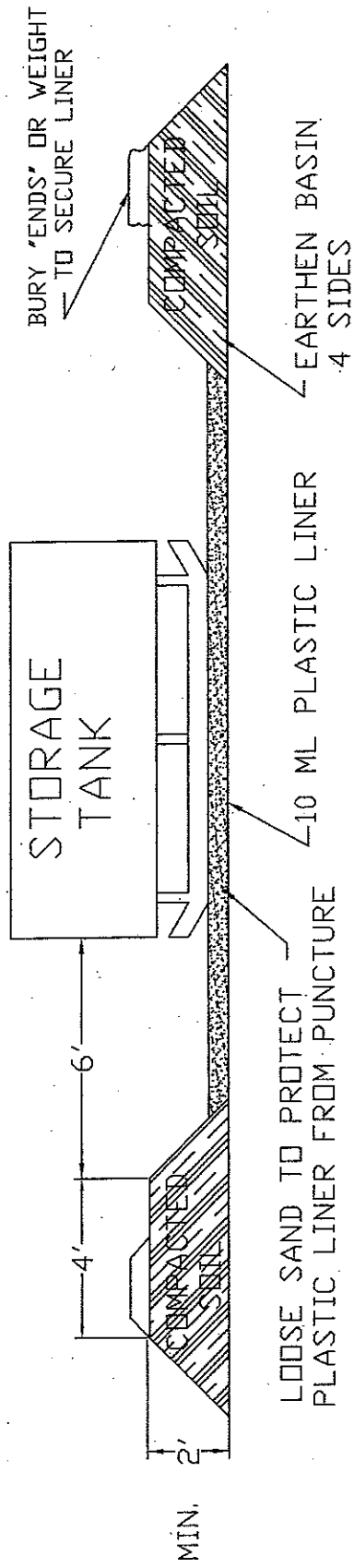

SELECTED HEIGHT OF EARTHEN BERM IS TO BE A TWO (2') FOOT MINIMUM OR ONE HUNDRED TEN PERCENT (110%) OF THE CAPACITY OF THE TANK(S) TOTAL VOLUME WITHIN THE BERM. A SIX (6") INCH FREEBOARD MUST BE INCLUDED.

NOTE: A TWO INCH (2") WATER REMOVAL DRAIN SHALL BE LOCATED AT THE LOWEST POINT IN THE BOTTOM OF THE CONTAINMENT VOLUME. IT SHALL CONNECT TO A NORMALLY CLOSED VALVE OUTSIDE THE DIKE. THE VALVE SHALL BE MANUALLY OPERATED AND PROTECTED FROM UNAUTHORIZED OPERATION. RAINWATER CONTAINED WITHIN THIS DIKE SHALL BE EXAMINED PRIOR TO RELEASE TO ENSURE THAT HARMFUL QUANTITIES OF FUELS AND LUBRICANTS ARE NOT DISCHARGED. ALTERNATE METHODS OF WATER REMOVAL WILL BE CONSIDERED FOR APPROVAL.

TANKS WITH SECONDARY CONTAINMENT MAY BE USED AS AN ALTERNATIVE.

CULVERT INSTALLATION

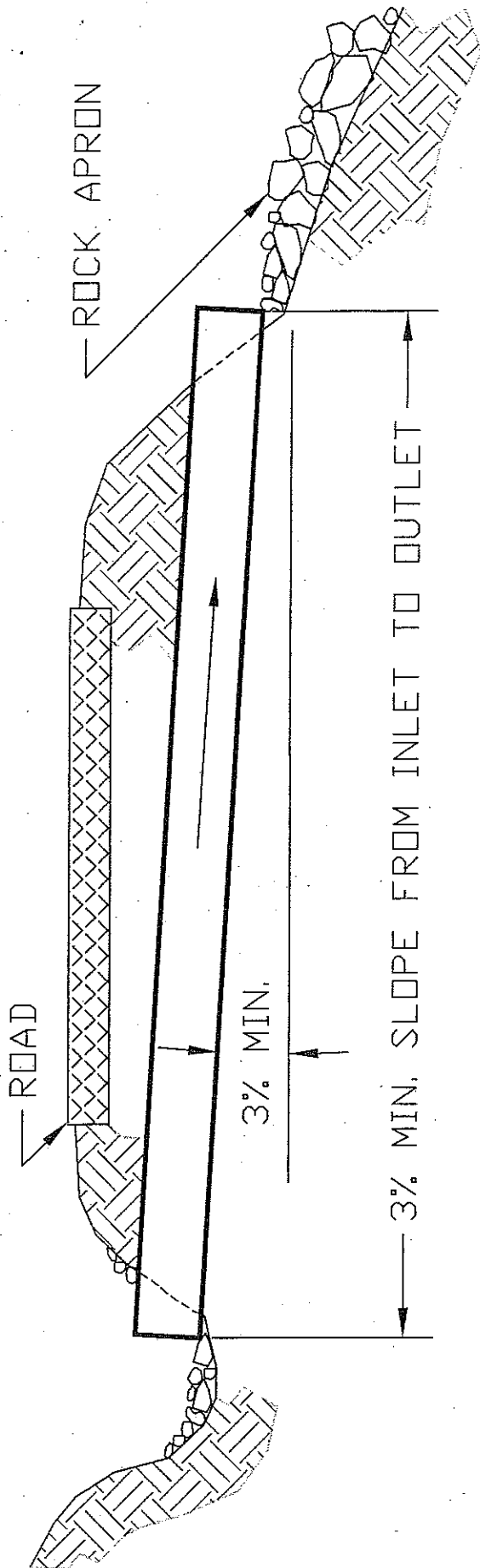

EARTHEN DIKE TO BE INSTALLED IN DITCH  
LINE BELOW CULVERT INLET

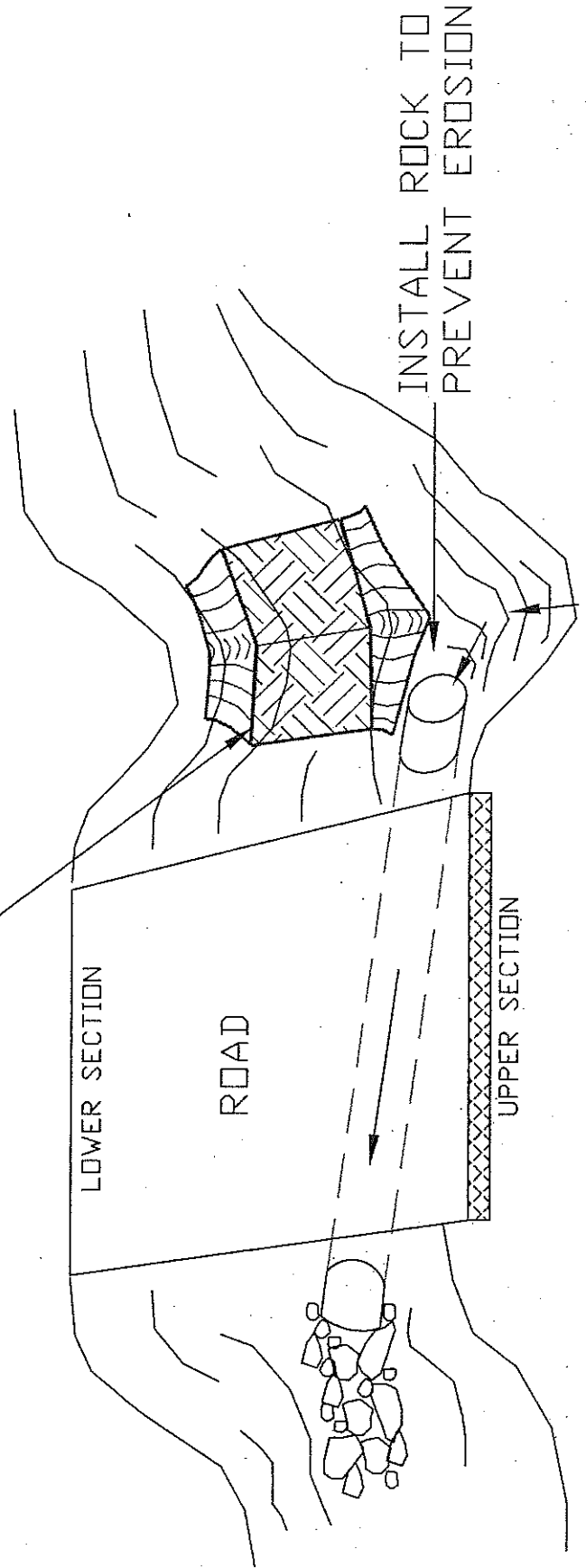

CULVERT INSTALLATION

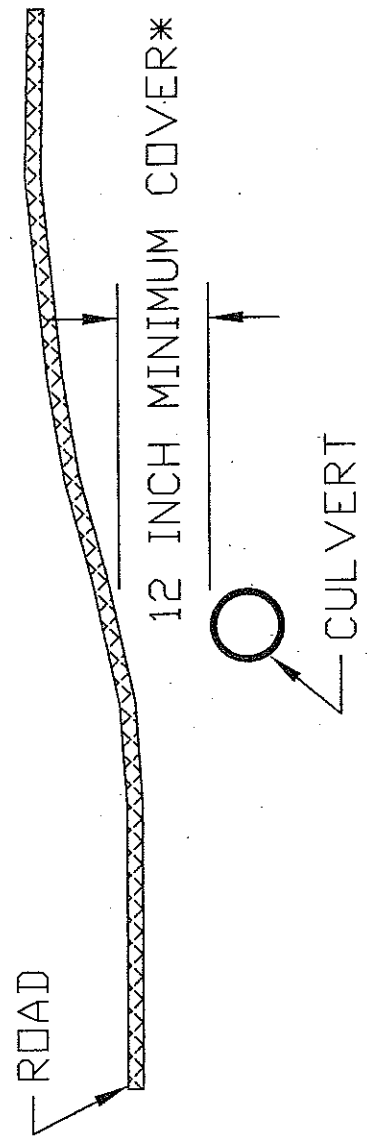
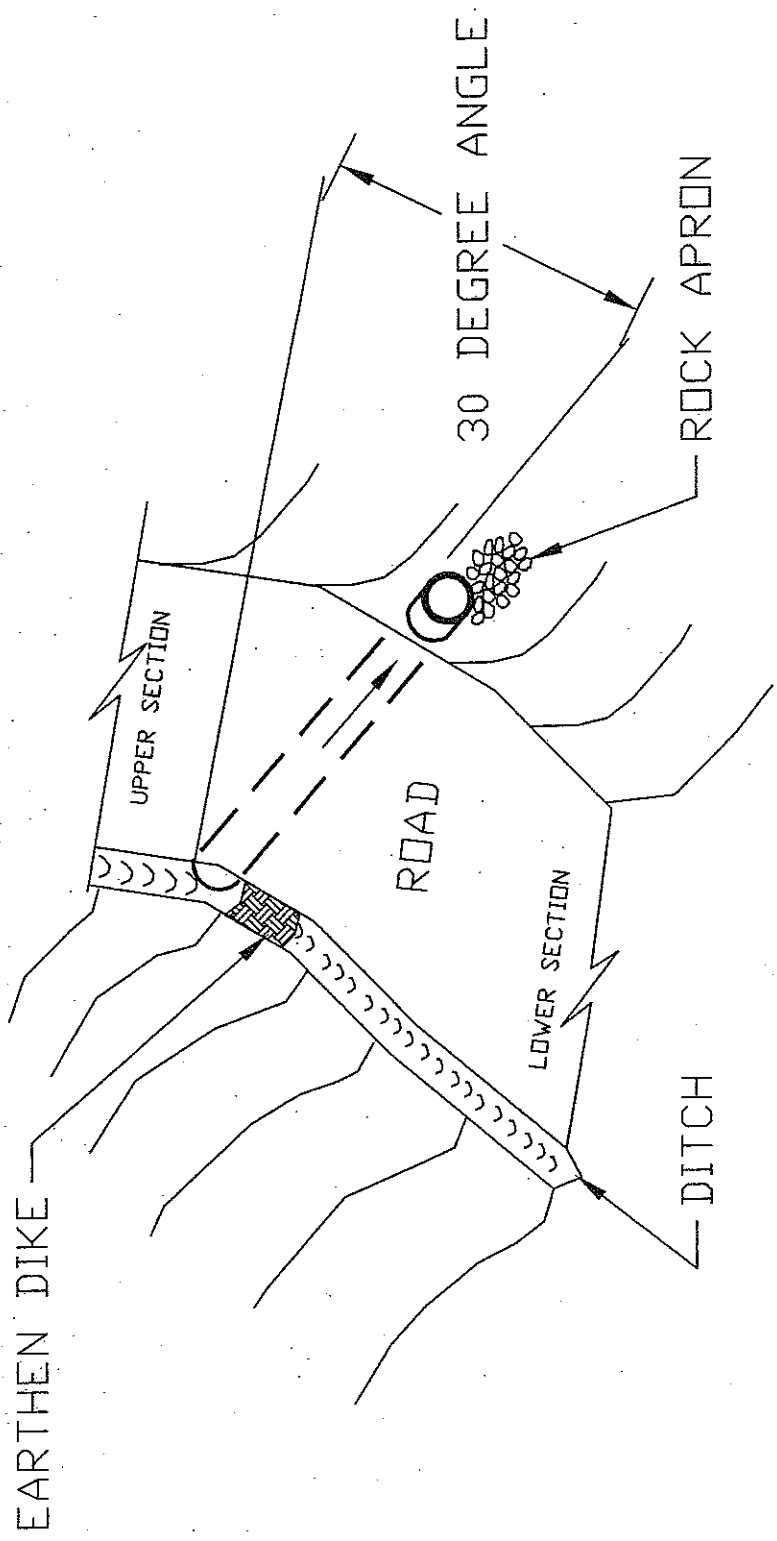

\*OR 1/2 CULVERT DIAMETER, WHICHEVER IS GREATER.



State of West Virginia  
 Department of Administration  
 Purchasing Division  
 2019 Washington Street East  
 Post Office Box 50130  
 Charleston, WV 25305-0130

# Request for Quotation

RFQ NUMBER  
 DEP14142

PAGE  
 1

ADDRESS CORRESPONDENCE TO ATTENTION OF:  
 CHUCK BOWMAN  
 304-558-2157

\*709052008      304 765 5288  
 MCCOURT & SON CONSTRUCTION INC  
 2790 CENTRALIA ROAD

SUTTON WV 26601

ENVIRONMENTAL PROTECTION  
 DEPT. OF  
 OFFICE OF SPECIAL RECLAMATION  
 105 S. RAILROAD STREET  
 PHILIPPI, WV  
 26416-9998      304-457-3219

VENDOR

SHIP TO

DATE PRINTED	TERMS OF SALE	SHIP VIA	FOB	FREIGHT TERMS
09/17/2007				

BID OPENING DATE: 10/02/2007      BID OPENING TIME 01:30PM

LINE	QUANTITY	UOP	CAT. NO.	ITEM NUMBER	UNIT PRICE	AMOUNT
				ADDENDUM NO. 1		
				ADDENDUM ISSUED FOR THE BUFFALO COAL COMPANY WATER PROJECT AS A RESULT OF THE MANDATORY PRE-BID MEETING OF 09/06/07. ATTACHED IS THE PRE-BID SIGN-IN SHEET AND THE VENDOR QUESTIONS/AGENCY ANSWERS & CLARIFICATIONS.		
				BID DATE HAS BEEN EXTENDED FROM 09/25/07 TO 10/02/07. BID OPENING TIME REMAINS 1:30 PM.		
				NO OTHER CHANGES		
0001		JB		962-73		\$456,082.50
				RECLAMATION: RESTORATION OF WATER		

SEE REVERSE SIDE FOR TERMS AND CONDITIONS

SIGNATURE <i>James McLean</i>	TELEPHONE 304-765-5288	DATE 10/02/2007
TITLE President	FEIN 55-062-4840	ADDRESS CHANGES TO BE NOTED ABOVE

WHEN RESPONDING TO RFQ, INSERT NAME AND ADDRESS IN SPACE ABOVE LABELED 'VENDOR'

**GENERAL TERMS & CONDITIONS  
REQUEST FOR QUOTATION (RFQ) AND REQUEST FOR PROPOSAL (RFP)**

1. Awards will be made in the best interest of the State of West Virginia.
2. The State may accept or reject in part, or in whole, any bid.
3. All quotations are governed by the *West Virginia Code* and the *Legislative Rules* of the Purchasing Division.
4. Prior to any award, the apparent successful vendor must be properly registered with the Purchasing Division and have paid the required \$125.00 registration fee.
5. All services performed or goods delivered under State Purchase Orders/Contracts are to be continued for the term of the Purchase Order/Contract, contingent upon funds being appropriated by the Legislature or otherwise being made available. In the event funds are not appropriated or otherwise available for these services or goods, this Purchase Order/Contract becomes void and of no effect after June 30.
6. Payment may only be made after the delivery and acceptance of goods or services.
7. Interest may be paid for late payment in accordance with the *West Virginia Code*.
8. Vendor preference will be granted upon written request in accordance with the *West Virginia Code*.
9. The State of West Virginia is exempt from federal and state taxes and will not pay or reimburse such taxes.
10. The Director of Purchasing may cancel any Purchase Order/Contract upon 30 days written notice to the seller.
11. The laws of the State of West Virginia and the *Legislative Rules* of the Purchasing Division shall govern all rights and duties under the Contract, including without limitation the validity of this Purchase Order/Contract.
12. Any reference to automatic renewal is hereby deleted. The Contract may be renewed only upon mutual written agreement of the parties.
13. **BANKRUPTCY:** In the event the vendor/contractor files for bankruptcy protection, this contract is automatically null and void, and is terminated without further order.
14. **HIPAA Business Associate Addendum** - The West Virginia State Government HIPAA Business Associate Addendum (BAA), approved by the Attorney General, and available online at the Purchasing Division's web site (<http://www.state.wv.us/admin/purchase/vrc/hipaa.htm>) is hereby made part of the agreement. Provided that, the Agency meets the definition of a Covered Entity (45 CFR §160.103) and will be disclosing Protected Health Information (45 CFR §160.103) to the vendor.

---

**INSTRUCTIONS TO BIDDERS**

1. Use the quotation forms provided by the Purchasing Division.
2. **SPECIFICATIONS:** Items offered must be in compliance with the specifications. Any deviation from the specifications must be clearly indicated by the bidder. Alternates offered by the bidder as **EQUAL** to the specifications must be clearly defined. A bidder offering an alternate should attach complete specifications and literature to the bid. The Purchasing Division may waive minor deviations to specifications.
3. Complete all sections of the quotation form.
4. Unit prices shall prevail in cases of discrepancy.
5. All quotations are considered F.O.B. destination unless alternate shipping terms are clearly identified in the quotation.
6. **BID SUBMISSION:** All quotations must be delivered by the bidder to the office listed below prior to the date and time of the bid opening. Failure of the bidder to deliver the quotations on time will result in bid disqualifications.

**SIGNED BID TO:**

Department of Administration  
Purchasing Division  
2019 Washington Street East  
Post Office Box 50130  
Charleston, WV 25305-0130

**Addendum #1 - Questions During Pre-Bid Meeting  
For DEP 14142  
Buffalo Coal Co. Permit # S-122-80**

- 1.) **Q.** Is the debris near the beginning of the road ditch repair part of the job?  
**A.** Yes, the steel tank and steel culvert pipe beside the main access road is part of the debris removal bid item.
- 2.) **Q.** Will the existing culvert be sealed?  
**A.** Yes, the question is answered in bid item #3, "an existing 36 inch diameter culvert draining the area behind the fill shall be sealed with cement grout".
- 3.) **Q.** The ditch crossing under the road through the woods, where does it come out into the seep collector? Will it enter the new 48" pipe?  
**A.** It does not come into the seep collector, the ditch in question was the fresh water diversion ditch which will divert water through the woods and around an existing building. No, the water will not enter the 48" pipe.
- 4.) **Q.** The area where the building is, how far does that (the earth to be excavated) come down? Can the dike material for the fresh water pond be built from that material?  
**A.** Whatever amount is needed to make the area behind the road fill to a non-impounding state. As much as 12 to 15 feet of depth may be excavated, or is available for removal at the building site. Yes, the material for the dikes can come from the area at the building site.
- 5.) **Q.** Are you going to grout the ditch from the Aquafix to the main ditch and grout the main ditch up to the 48 inch culvert?  
**A.** Yes, grout both ditches and we may not grout up to the 48 inch culvert if seeps are encountered during construction. We may start grouting the main ditch at the Aquafix location. Plan for the grout to go all the way up to the 48 inch culvert.
- 6.) **Q.** Whenever you start the grout (in the main ditch) did you spec. a keyway in it... to keep the water from running under the grout?  
**A.** We will determine how to start the grout during construction onsite, we do not have a spec. for it. We may dig a keyway in, or we may run the grout the entire length of ditch up to the 48 inch pipe. **Clarification: Plan to grout the ditch up to the 48 inch culvert.**
- 7.) **Q.** Is the 48 inch pipe actually an overflow for the other side?  
**A.** Yes, correct... The 48 inch pipe is an overflow for any water impounded by the existing road fill.
- 8.) **Q.** (Cleaning of the Treatment Pond) Do we clean 10 feet from the normal water pool or from the top?  
**A.** Sediment from the existing treatment pond shall be removed to a depth of 10 feet from the old water line (or normal water pool). Both sides of the pond shall be cleaned.



- 9.) Q. Is this the pond that was 15 feet deep?  
A. It may be in the lower end of the pond, but we don't know.
- 10.) Q. Is that spillway incidental or is it a separate line item?  
A. No, that is a separate line item, that is the exit spillway channel and we are paying for that by the linear foot.
- 11.) Q. Does the dike through the pond have to be as high as the outer embankment, or just have 2 to 3 feet of freeboard?  
A. As long as the dike has 2 to 3 feet of freeboard, and the outer embankment has at least the same amount of freeboard to match the dike.
- 12.) Q. Do we have to remove sludge from the pond 10 feet from the old water line, or from the existing water line?  
A. From the old water line ... as you can see it is down now. (The pond water level had been lowered for cleaning) We are going to raise the pond water level back up to that level (the old water line). **Clarification: The old water line is about 3 feet lower than the top of the outer embankment. Clean sediment and sludge 10 feet from the old water line, or a total of 13 feet from the top of the outer embankment down.**
- 13.) Q. Do we have to treat this water as the contractor?  
A. No, our people will be treating the water.
- 14.) Q. Is there a 12 feet wide bench around all of this (the Treatment Pond), correct?  
A. Yes, correct. We want to be able to build a fence around the pond after construction. On all of our new ponds, we want to have access around the ponds and to be able to fence these ponds.
- 15.) Q. What size will the sludge cell be?  
A. Talking about the new sludge cell, Bid Item #11, the cell shall have a volume of 128,000 cubic feet with bottom dimensions of 140 feet by 60 feet, and we can alter that to meet site conditions, as long as we get the volume that we ask for as specified in the plans. The sludge cell has a 10 feet total depth.
- 16.) Q. Are you going to allow us to put some of this (pond cleanings) here (pointing below the pond outer embankment)?  
A. We have all of this space up here (above the new sludge cell site), put it (pond cleanings) up here. If you need to dig a cell to put it in, you must reclaim it and revegetate it. Or, you can take pond cleanings to the old building site.

MANDATORY PRE-BID SIGN-IN ATTENDANCE SHEET

RFQ # : DEP14142  
Project: Buffalo Coal Company, Inc.  
S-122-80

Bid Date: 9/25/07  
Pre-Bid Date: 9/6/07

Name : DAVID H. Bowman  
Company: GREEN MOUNTAIN Co  
Address: 511 50th STREET  
CHARLESTON WV 25304

Name : James STARBUCK  
Company: Mountain-top Leasing  
Address: P.O. Box 159  
Elkhorn WV 26220

Phone #: 904 925 0253  
Fax #: 304 925 9230  
Email : Jody.Maye@OL.com

Phone# : 304-548-6800  
Fax # : 304-548-6900  
Email :

Name : Robert Baines  
Company: BAINES EXL, INC.  
Address: P.O. BOX 13384  
Sissonville  
WV 25360

Name : Garry Long  
Company: McCourt & Son Const.  
Address: 2790 Centralia Rd  
Sutton WV 26601

Phone #: 304-984-1725  
Fax # : 304-984-0074  
Email : none

Phone# : 304 765-5288  
Fax # : 304 765-5293  
Email :

Name : Steven Freshour  
Company: Eagle Excavation Inc.  
Address: P.O. Box 218  
Kenna WV 25248

Name : LEDNIS GILKERSON  
Company: G.L. STONE & SON  
Address: 24 FIRST STREET  
HAMLIN, WV 25525

Phone #: 304-372-4378  
Fax # : 304-372-4378  
Email :

Phone# : 304 824 3800  
Fax # : 304 824 3848  
Email :

Name : H Craig Stupka  
Company: Hydro Tech  
Address: 900 Pine Grove Rd  
Summers WV 25567

Name : NANCY SOMERS  
Company: MIDWAY RECLAMATION LLC  
Address: P.O. BOX 308  
WEST MILFORD, WV 26451

Phone #: 304-382-8080  
Fax # : 304-204-0083  
Email : schultzlance@aol.com

Phone# : 304-745-3652  
Fax # : 304-745-3653  
Email :

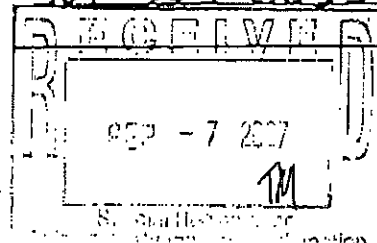

MANDATORY PRE-BID SIGN-IN ATTENDANCE SHEET

RFQ # : DEP14142  
Project: Buffalo Coal Company, Inc.  
S-122-80

Bid Date: 9/25/07  
Pre-Bid Date: 9/6/07

Name : Steve Jurasko  
Company: Polina Contracting Inc  
Address: PO Box 230  
Elkins WV 26241  
Phone #: 304-636-3886  
Fax #: 304-636-5108  
Email : SJurasko@Polina.com

Name : Spencer Wooddell  
Company: Cowgirl Up Inc  
Address: PO Box 243  
Simpson WVa 26435  
Phone#: 304-739-4397  
Fax #: \_\_\_\_\_  
Email : \_\_\_\_\_

Name : LONNIE WALTON  
Company: BEAR CONTRACTING  
Address: P.O. Box 1196  
BRIDGEPORT WV  
Phone #: 304 842-3002  
Fax #: 304 842-9433  
Email : \_\_\_\_\_

Name : John Skidmore  
Company: Mountain News  
Address: 305 39th St  
Charleston, WV 25304  
Phone#: 925-4834  
Fax #: 925-4032  
Email : \_\_\_\_\_

Name : Thane Ryder  
Company: RIS Inc.  
Address: PO Box 490  
White Sulphur Springs  
WV 24986  
Phone #: (304) 645-2277  
Fax #: \_\_\_\_\_  
Email : \_\_\_\_\_

Name : Doug Vincent  
Company: BREAKAWAY Inc.  
Address: 1075 old Turnpike Rd  
Sutton, WV 26601  
Phone#: 765-5317  
Fax #: 765-5389  
Email : breakaway.inc@verizon.net

Name : Thane Ryder  
Company: Appalachian Contracting Co  
Address: HC 82 Box 199  
Marlinton WV 24954  
Phone #: (304) 799-4488  
Fax #: \_\_\_\_\_  
Email : \_\_\_\_\_

Name : ~~\_\_\_\_\_~~  
Company: ~~\_\_\_\_\_~~  
Address: ~~\_\_\_\_\_~~  
Phone#: ~~\_\_\_\_\_~~  
Fax #: ~~\_\_\_\_\_~~  
Email : ~~\_\_\_\_\_~~  
*9/6/07*  
*(DEP)*

Bond# 5507

Agency Purchasing  
REQ.P.O# DEP14142

**BID BOND**

KNOW ALL MEN BY THESE PRESENTS, That we, the undersigned, McCourt & Son Construction, Inc.

of 2790 Centralia Road, Sutton, WV 26601

, as Principal, and Companion Property and Casualty

Insurance Company of 18051 Jefferson Park Rd #104 Middleburg, Wts OH 44130

S Carolina with its principal office in the City of Atlanta, GA, as Surety, are held and firmly bound unto the State

of West Virginia, as Obligee, in the penal sum of Twenty Eight Thousand (\$ 28,875.00) for the payment of which, well and truly to be made, we jointly and severally bind ourselves, our heirs, administrators, executors, successors and assigns.

The Condition of the above obligation is such that whereas the Principal has submitted to the Purchasing Section of the Department of Administration a certain bid or proposal, attached hereto and made a part hereof, to enter into a contract in writing for DEP 14142 Water reclamation on the mining operation of Buffalo Coal Company, Inc.  
Thomas, W Tucker Co.

NOW THEREFORE,

(a) If said bid shall be rejected, or

(b) If said bid shall be accepted and the Principal shall enter into a contract in accordance with the bid or proposal attached hereto and shall furnish any other bonds and insurance required by the bid or proposal, and shall in all other respects perform the agreement created by the acceptance of said bid, then this obligation shall be null and void, otherwise this obligation shall remain in full force and effect. It is expressly understood and agreed that the liability of the Surety for any and all claims hereunder shall, in no event, exceed the penal amount of this obligation as herein stated.

The Surety, for the value received, hereby stipulates and agrees that the obligations of said Surety and its bond shall be in no way impaired or affected by any extension of the time within which the Obligee may accept such bid, and said Surety does hereby waive notice of any such extension.

IN WITNESS WHEREOF, Principal and Surety have hereunto set their hands and seals, and such of them as are corporations have caused their corporate seals to be affixed hereunto and these presents to be signed by their proper officers, this 25th day of September, 20 07.

Principal Corporate Seal

McCourt & Son Construction, Inc.

(Name of Principal)

By [Signature]  
(Must be President or Vice President)

President

(Title)

Surety Corporate Seal

Companion Property and Casualty Insurance Company

(Name of Surety)

[Signature]  
Attorney-in-Fact  
Andrew C. Heaner

**IMPORTANT - Surety executing bonds must be licensed in West Virginia to transact surety insurance. Raised corporate seals must be affixed, a power of attorney must be attached.**

# COMPANION PROPERTY AND CASUALTY INSURANCE COMPANY

P. O. Box 100165 (29202)  
51 Clemson Road  
Columbia, SC 29229

## GENERAL POWER OF ATTORNEY

Know all men by these Presents, that the COMPANION PROPERTY AND CASUALTY INSURANCE COMPANY had made, Constituted and appointed, and by these presents does make, Constitute and appoint Andrew C. Heaner of Atlanta, Georgia; Richard L. Shanahan of Atlanta, Georgia; Stefan E. Tauger of Parker, Colorado; Arthur S. Johnson of Atlanta, Georgia; Jessica B. Gardiner of Loganville, Georgia; Mary F. Holland of Chamblee, Georgia; James E. Feldner of West Lake, Ohio; Jeffery L. Booth of Parma, Ohio; Cheryl L. Torrao of Canton, Georgia; Garry W. Black of Murfreesboro, Tennessee; Martha G. Ross of Charlotte, North Carolina; David R. Brett of Columbia, South Carolina; or Donald H. Gibbs of Atlanta, Georgia, EACH as its true and lawful attorney for it and its name, place and stead to execute on behalf of the said company, as surety, bonds, undertakings and contracts of suretyship to be given to all obligees provided that no bond or undertaking or contract of suretyship executed under this authority shall exceed in amount of the sum of **\$1,000,000 (One Million dollars)**.

This Power of Attorney is granted and is signed and sealed by facsimile under and by the authority of the following Resolution adopted pursuant to due authorization by the Executive Committee of the Board of Directors of the COMPANION PROPERTY AND CASUALTY INSURANCE COMPANY on the 24<sup>th</sup> day of December 2003.

RESOLVED, that the Chairman, President or any Vice President of the Company be, and that each or any of them hereby is, authorized to execute Powers of Attorney qualifying the attorney named in the given Power of Attorney to execute in behalf of the COMPANION PROPERTY AND CASUALTY INSURANCE COMPANY bonds, undertakings and all contracts of suretyship; and that any Officer, Secretary or any Assistant Secretary be, and that each or any of them hereby is, authorized to attest the execution of any such Power of Attorney, and to attach thereto the seal of the Company.

FURTHER RESOLVED, that the signature of such officers and the seal of the Company may be affixed to any such Power of Attorney or to any certificate relating thereto by facsimile, and any such Power of Attorney certificate bearing such facsimile signatures or facsimile seal shall be valid and binding upon the Company when so affixed and in the future, with respect to any bond undertaking or contract of suretyship to which it is attached.

In Witness Whereof, the COMPANION PROPERTY AND CASUALTY INSURANCE COMPANY has caused its official seal to be hereto affixed, and these presents to be signed by its President and attested by its Vice President this 22<sup>nd</sup> day of December 2006.

Attest: COMPANION PROPERTY AND CASUALTY INSURANCE COMPANY

By: \_\_\_\_\_

Charles M. Potok, President

\_\_\_\_\_  
Curtis C. Stewart, Vice President & CFO

STATE OF SOUTH CAROLINA

COUNTY OF RICHLAND

On this 22<sup>nd</sup> day of December, 2006, before me personally came the above named officers to me known, who being by me duly sworn, did depose and say that they reside in Columbia, in the County of Richland, State of SC, at Columbia; that they are the President and Vice President & CFO of COMPANION PROPERTY AND CASUALTY INSURANCE COMPANY, the corporation described in and which executed the above instrument; that they know the seal of the said corporation; that the seal affixed to the said instrument is such corporate seal; that it was so affixed and that they signed their names thereto pursuant to due authorization.

Notary Public, State of SC, Qualified in Richland County Commission Expires: 7/16/14

STATE OF SOUTH CAROLINA

COUNTY OF RICHLAND

I, the undersigned, an Officer of COMPANION PROPERTY AND CASUALTY INSURANCE COMPANY, a South Carolina Corporation, DO HEREBY CERTIFY that the foregoing and attached Power of Attorney remains in full force and has not been revoked; and, furthermore, that the Resolution of the Executive Committee of the Board of Directors set forth in the Power of Attorney is now in force.

Signed and sealed at the City of Columbia, Dated the 25<sup>th</sup> day of September, 2007

\_\_\_\_\_  
Curtis C. Stewart, Vice President & CFO

*State of West Virginia*  
*Offices of the Insurance Commissioner*  
*Certificate of Authority*

*Whereas*, **COMPANION PROPERTY AND CASUALTY INSURANCE COMPANY** domiciled in the State of South Carolina has complied with all the requirements of the laws of this State so as to entitle it to transact its appropriate business in the State of West Virginia.

*Therefore*, I the undersigned, Insurance Commissioner of the State of West Virginia, pursuant to the authority vested in me by the laws of this State, do hereby authorize it to transact the business of insurance as defined in Chapter 33

ARTICLE 1, SECTION 10(c) -- FIRE  
ARTICLE 1, SECTION 10(d) -- MARINE  
ARTICLE 1, SECTION 10(e) -- CASUALTY  
ARTICLE 1, SECTION 10(f) (1) (2) & (3) -- SURETY

of the 1931 Code of West Virginia as amended, in the State of West Virginia in accordance with the laws thereof until midnight on the 31<sup>st</sup> day of May, 2008, unless this license be sooner revoked. Pursuant to W. Va. Code 33-3-2(c), the above authorization does not allow the insurer to transact a kind of insurance in this State unless duly authorized or qualified to transact such insurance in the state or country of its domicile.

*In Testimony Whereof*, I have hereunto set my hand and affixed my seal of office at the City of Charleston this 1<sup>st</sup> day of June, 2007.

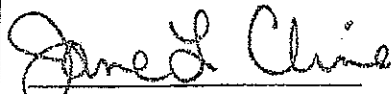
  
Jane L. Cline  
Insurance Commissioner



WV File #1602

STATE OF WEST VIRGINIA  
Purchasing Division**PURCHASING AFFIDAVIT**

062

**West Virginia Code §5A-3-10a states:** No contract or renewal of any contract may be awarded by the state or any of its political subdivisions to any vendor or prospective vendor when the vendor or prospective vendor or a related party to the vendor or prospective vendor is a debtor and the debt owed is an amount greater than one thousand dollars in the aggregate

**DEFINITIONS:**

"Debt" means any assessment, premium, penalty, fine, tax or other amount of money owed to the state or any of its political subdivisions because of a judgment, fine, permit violation, license assessment, defaulted workers' compensation premium, penalty or other assessment presently delinquent or due and required to be paid to the state or any of its political subdivisions, including any interest or additional penalties accrued thereon.

"Debtor" means any individual, corporation, partnership, association, limited liability company or any other form or business association owing a debt to the state or any of its political subdivisions. "Political subdivision" means any county commission; municipality; county board of education; any instrumentality established by a county or municipality; any separate corporation or instrumentality established by one or more counties or municipalities, as permitted by law; or any public body charged by law with the performance of a government function or whose jurisdiction is coextensive with one or more counties or municipalities. "Related party" means a party, whether an individual, corporation, partnership, association, limited liability company or any other form or business association or other entity whatsoever, related to any vendor by blood, marriage, ownership or contract through which the party has a relationship of ownership or other interest with the vendor so that the party will actually or by effect receive or control a portion of the benefit, profit or other consideration from performance of a vendor contract with the party receiving an amount that meets or exceed five percent of the total contract amount.

**EXCEPTION:** The prohibition of this section does not apply where a vendor has contested any tax administered pursuant to chapter eleven of this code, workers' compensation premium, permit fee or environmental fee or assessment and the matter has not become final or where the vendor has entered into a payment plan or agreement and the vendor is not in default of any of the provisions of such plan or agreement.

**LICENSING:** Vendors must be licensed and in good standing in accordance with any and all state and local laws and requirements by any state or local agency of West Virginia, including, but not limited to, the West Virginia Secretary of State's Office, the West Virginia Tax Department, West Virginia Insurance Commission, or any other state agencies or political subdivision. Furthermore, the vendor must provide all necessary releases to obtain information to enable the Director or spending unit to verify that the vendor is licensed and in good standing with the above entities.

**CONFIDENTIALITY:** The vendor agrees that he or she will not disclose to anyone, directly or indirectly, any such personally identifiable information or other confidential information gained from the agency, unless the individual who is the subject of the information consents to the disclosure in writing or the disclosure is made pursuant to the agency's policies, procedures and rules. Vendors should visit [www.state.wv.us/admin/purchase/privacy](http://www.state.wv.us/admin/purchase/privacy) for the Notice of Agency Confidentiality Policies.

Under penalty of law for false swearing (West Virginia Code, §61-5-3), it is hereby certified that the vendor acknowledges the information in this said affidavit and are in compliance with the requirements as stated.

Vendor's Name: McCourt & Son Construction, Inc.

Authorized Signature:  Date: 10/02/2007