



State of West Virginia  
 Department of Administration  
 Purchasing Division  
 2019 Washington Street East  
 Post Office Box 50130  
 Charleston, WV 25305-0130

# Request for Quotation

RFQ NUMBER  
**DEFK8138**

PAGE  
**1**

ADDRESS CORRESPONDENCE TO ATTENTION OF:  
**JOHN ABBOTT**  
**304-558-2544**

**RFQ COPY**

**TYPE NAME/ADDRESS HERE**

Hager Construction, LLC  
 5317 Cherry Lawn Drive  
 Huntington, WV 25705

**DIV ENGINEERING & FACILITIES**  
**UNITED STATES PROPERTY**  
**FISCAL OFFICE**  
**50 ARMORY ROAD**  
**BUCKHANNON, WV**  
**26201-8818**

DATE PRINTED	TERMS OF SALE	SHIP VIA	FOB	FREIGHT TERMS
12/02/2007				

BID OPENING DATE: **01/09/2008** BID OPENING TIME **01:30PM**

LINE	QUANTITY	UOP	CAT NO	ITEM NUMBER	UNIT PRICE	AMOUNT
0001	1	LS		031-78		SEE ATTACHED
<p><b>EXHAUST REMOVAL SYSTEM</b></p> <p><b>CONTRACT TO PROVIDE ALL LABOR, MATERIALS, AND EQUIPMENT TO REMOVE AN EXISTING VEHICULAR EXHAUST REMOVAL SYSTEM AND INSTALL A NEW SYSTEM, PER THE SPECIFICATIONS</b></p> <p><b>MANDATORY ON-SITE PRE-BID: WV NATL. GAURD ARMORY            FMS #2 FACILITY            50 ARMORY ROAD            BUCKHANNON, WV 26201</b></p> <p><b>PRE-BID DATE &amp; TIME: 12/9/2007; 10:00 AM</b></p> <p><b>FAILURE TO ATTEND THE PRE-BID WILL AUTOMATICALLY RESULT IN DISQUALIFICATION.</b></p> <p><b>EXHIBIT 5</b></p> <p><b>NOTICE TO PROCEED: THIS CONTRACT IS TO BE PERFORMED WITHIN 120 CALENDAR DAYS AFTER THE NOTICE TO PROCEED IS RECEIVED. UNLESS OTHERWISE SPECIFIED, THE FULLY EXECUTED PURCHASE ORDER WILL BE CONSIDERED NOTICE TO PROCEED.</b></p> <p><b>CANCELLATION: THE DIRECTOR OF PURCHASING RESERVES THE RIGHT TO CANCEL THIS CONTRACT IMMEDIATELY UPON WRITTEN NOTICE TO THE VENDOR IF THE MATERIALS OR WORKMANSHIP SUPPLIED ARE OF AN INFERIOR QUALITY OR DO NOT CONFORM WITH THE SPECIFICATIONS OF THE BID AND CONTRACT</b></p>						

REC'D  
 2008 JAN -9 P 1:21  
 PURCHASING DIVISION  
 STATE OF WV

SEE REVERSE SIDE FOR TERMS AND CONDITIONS

SIGNATURE <i>R. A. [Signature]</i>	TELEPHONE 304-302-7885	DATE 1/9/2008
TITLE Owner	FEIN 55-0772956	ADDRESS CHANGES TO BE NOTED ABOVE

WHEN RESPONDING TO RFQ, INSERT NAME AND ADDRESS IN SPACE ABOVE LABELED 'VENDOR'

**GENERAL TERMS & CONDITIONS  
REQUEST FOR QUOTATION (RFQ) AND REQUEST FOR PROPOSAL (RFP)**

1. Awards will be made in the best interest of the State of West Virginia.
2. The State may accept or reject in part, or in whole, any bid.
3. All quotations are governed by the *West Virginia Code* and the *Legislative Rules* of the Purchasing Division.
4. Prior to any award, the apparent successful vendor must be properly registered with the Purchasing Division and have paid the required \$125.00 registration fee.
5. All services performed or goods delivered under State Purchase Orders/Contracts are to be continued for the term of the Purchase Order/Contract, contingent upon funds being appropriated by the Legislature or otherwise being made available. In the event funds are not appropriated or otherwise available for these services or goods, this Purchase Order/Contract becomes void and of no effect after June 30.
6. Payment may only be made after the delivery and acceptance of goods or services.
7. Interest may be paid for late payment in accordance with the *West Virginia Code*.
8. Vendor preference will be granted upon written request in accordance with the *West Virginia Code*.
9. The State of West Virginia is exempt from federal and state taxes and will not pay or reimburse such taxes.
10. The Director of Purchasing may cancel any Purchase Order/Contract upon 30 days written notice to the seller.
11. The laws of the State of West Virginia and the *Legislative Rules* of the Purchasing Division shall govern all rights and duties under the Contract, including without limitation the validity of this Purchase Order/Contract.
12. Any reference to automatic renewal is hereby deleted. The Contract may be renewed only upon mutual written agreement of the parties.
13. **BANKRUPTCY:** In the event the vendor/contractor files for bankruptcy protection, this Contract may be deemed null and void, and terminated without further order.
14. **HIPAA Business Associate Addendum** - The West Virginia State Government HIPAA Business Associate Addendum (BAA), approved by the Attorney General, and available online at the Purchasing Division's web site (<http://www.state.wv.us/admin/purchase/vrc/hipaa.htm>) is hereby made part of the agreement. Provided that, the Agency meets the definition of a Covered Entity (45 CFR §160.103) and will be disclosing Protected Health Information (45 CFR §160.103) to the vendor.

---

**INSTRUCTIONS TO BIDDERS**

1. Use the quotation forms provided by the Purchasing Division.
2. **SPECIFICATIONS:** Items offered must be in compliance with the specifications. Any deviation from the specifications must be clearly indicated by the bidder. Alternates offered by the bidder as **EQUAL** to the specifications must be clearly defined. A bidder offering an alternate should attach complete specifications and literature to the bid. The Purchasing Division may waive minor deviations to specifications.
3. Complete all sections of the quotation form.
4. Unit prices shall prevail in cases of discrepancy.
5. All quotations are considered F.O.B. destination unless alternate shipping terms are clearly identified in the quotation.
6. **BID SUBMISSION:** All quotations must be delivered by the bidder to the office listed below prior to the date and time of the bid opening. Failure of the bidder to deliver the quotations on time will result in bid disqualifications.

**SIGNED BID TO:**

Department of Administration  
Purchasing Division  
2019 Washington Street East  
Post Office Box 50130  
Charleston, WV 25305-0130



State of West Virginia  
 Department of Administration  
 Purchasing Division  
 2019 Washington Street East  
 Post Office Box 50130  
 Charleston, WV 25305-0130

# Request for Quotation

RFQ NUMBER  
**DEFK8138**

PAGE  
**2**

ADDRESS CORRESPONDENCE TO ATTENTION OF  
**JOHN ABBOTT  
 304-558-2544**

**RFQ COPY**

**TYPE NAME/ADDRESS HERE**

Hager Construction, LLC  
 5317 Cherry Lawn Drive  
 Huntington, WV 25705

**DIV ENGINEERING & FACILITIES  
 UNITED STATES PROPERTY  
 FISCAL OFFICE  
 50 ARMORY ROAD  
 BUCKHANNON, WV  
 26201-8818**

DATE PRINTED	TERMS OF SALE	SHIP VIA	F.O.B.	FREIGHT TERMS
12/02/2007				

BID OPENING DATE: **01/09/2008** BID OPENING TIME **01:30PM**

LINE	QUANTITY	UOP	CAT NO	ITEM NUMBER	UNIT PRICE	AMOUNT
<p>HERE IN.</p> <p>WAGE RATES: THE CONTRACTOR OR SUBCONTRACTOR SHALL PAY THE HIGHER OF THE U.S. DEPARTMENT OF LABOR MINIMUM WAGE RATES AS ESTABLISHED FOR UPSHUR COUNTY, PURSUANT TO WEST VIRGINIA CODE 21-5A, ET, SEQ. (PREVAILING WAGE RATES APPLY TO THIS PROJECT)</p> <p>ARBITRATION: ANY REFERENCES MADE TO ARBITRATION OR INTEREST FOR PAYMENTS DUE (EXCEPT FOR ANY INTEREST REQUIRED BY STATE LAW) CONTAINED IN THIS CONTRACT OR IN ANY AMERICAN INSTITUTE OF ARCHITECTS DOCUMENTS PERTAINING TO THIS CONTRACT ARE HEREBY DELETED.</p> <p>WORKERS' COMPENSATION: VENDOR IS REQUIRED TO PROVIDE A CERTIFICATE FROM WORKERS' COMPENSATION IF SUCCESSFUL.</p> <p>ALL OF THE ITEMS CHECKED BELOW WILL BE A REQUIREMENT OF THIS CONTRACT:</p> <p>(XX) INSURANCE: SUCCESSFUL VENDOR SHALL FURNISH PROOF OF COMMERCIAL GENERAL LIABILITY INSURANCE PRIOR TO ISSUANCE OF CONTRACT. UNLESS OTHERWISE SPECIFIED IN THE BID DOCUMENTS, THE MINIMUM AMOUNT OF INSURANCE COVERAGE REQUIRED IS \$250,000.</p> <p>( ) BUILDERS RISK INSURANCE: SUCCESSFUL VENDOR SHALL FURNISH PROOF OF BUILDERS RISK - ALL RISK INSURANCE IN AN AMOUNT EQUAL TO 100% OF THE AMOUNT OF THE CONTRACT.</p> <p>(XX) BONDS: FIVE PERCENT (5%) OF THE TOTAL AMOUNT OF THE BID PAYABLE TO THE STATE OF WEST VIRGINIA, SHALL BE SUBMITTED WITH EACH BID AS A BID BOND. THE SUCCESSFUL BIDDER SHALL ALSO FURNISH A PERFORMANCE BOND AND LABOR/MATERIAL BOND FOR 100% OF THE AMOUNT OF THE CONTRACT. BONDS MAY BE PROVIDED IN THE FORM OF A CERTIFIED CHECK</p>						

SEE REVERSE SIDE FOR TERMS AND CONDITIONS

SIGNATURE <i>R. Hager</i>	TELEPHONE 304-302-7885	DATE 1/9/2008
TITLE Owner	FEIN 55-0772956	ADDRESS CHANGES TO BE NOTED ABOVE

WHEN RESPONDING TO RFQ, INSERT NAME AND ADDRESS IN SPACE ABOVE LABELED 'VENDOR'



State of West Virginia  
 Department of Administration  
 Purchasing Division  
 2019 Washington Street East  
 Post Office Box 50130  
 Charleston, WV 25305-0130

# Request for Quotation

RFQ NUMBER  
**DEFK8138**

PAGE  
**3**

ADDRESS CORRESPONDENCE TO ATTENTION OF  
**JOHN ABBOTT**  
**304-558-2544**

RFQ COPY

TYPE NAME/ADDRESS HERE

Hager Construction, LLC  
 5317 Cherry Lawn Drive  
 Huntington, WV 25705

DIV ENGINEERING & FACILITIES  
 UNITED STATES PROPERTY  
 FISCAL OFFICE  
 50 ARMORY ROAD  
 BUCKHANNON, WV  
 26201-8818

DATE PRINTED	TERMS OF SALE	SHIP VIA	FOB	FREIGHT TERMS
12/02/2007				

BID OPENING DATE: **01/09/2008** BID OPENING TIME **01:30PM**

LINE	QUANTITY	UOP	CAT NO	ITEM NUMBER	UNIT PRICE	AMOUNT
<p>IRREVOCABLE LETTER OF CREDIT, OR BOND FURNISHED BY A SOLVENT SURETY COMPANY AUTHORIZED TO DO BUSINESS IN THE STATE OF WEST VIRGINIA. A LETTER OF CREDIT SUBMITTED IN LIEU OF A PERFORMANCE AND LABOR &amp; MATERIAL BOND WILL ONLY BE ALLOWED FOR PROJECTS UNDER \$100,000. PERSONAL OR BUSINESS CHECKS ARE NOT ACCEPTABLE IN LIEU OF THE 5% BID BOND, PERFORMANCE BOND, OR LABOR AND MATERIAL BOND.</p> <p>( ) MAINTENANCE BOND: A TWO (2) YEAR MAINTENANCE BOND COVERING THE ROOFING SYSTEM WILL BE A REQUIREMENT OF THE SUCCESSFUL VENDOR.</p> <p>REV. 11/00</p> <p>EXHIBIT 7</p> <p>DOMESTIC ALUMINUM, GLASS &amp; STEEL IN PUBLIC WORKS PROJECTS</p> <p>IN ACCORDANCE WITH WEST VIRGINIA CODE 5-19-1 ET., SEQ., EVERY CONTRACT FOR CONSTRUCTION, RECONSTRUCTION, ALTERATION, REPAIR, IMPROVEMENT OR MAINTENANCE OF PUBLIC WORKS, WHERE THE COST IS MORE THAN \$50,000 AND, IN THE CASE OF STEEL ONLY, WHERE THE COST OF STEEL IS MORE THAN \$50,000 OR WHERE MORE THAN 10,000 POUNDS OF STEEL ARE REQUIRED, THE STATE WILL ACCEPT ONLY ALUMINUM GLASS, OR STEEL PRODUCTS PRODUCED IN THE UNITED STATES. IN ADDITION, ITEMS OF MACHINERY OR EQUIPMENT PURCHASED FOR USE AT THE SITE OF PUBLIC WORKS SHALL BE MADE OF DOMESTIC ALUMINUM, GLASS OR STEEL, UNLESS THE COST OF THE PRODUCT IS LESS THAN \$50,000 OR LESS THAN 10,000 POUNDS OF STEEL ARE USED IN PUBLIC WORKS PROJECTS.</p> <p>FOREIGN MADE ALUMINUM, GLASS OR STEEL PRODUCTS MAY BE</p>						

SEE REVERSE SIDE FOR TERMS AND CONDITIONS

SIGNATURE <i>R. Abbott</i>	TELEPHONE 304-302-7885	DATE 1/9/2008
TITLE Owner	FEIN 55-0772956	ADDRESS CHANGES TO BE NOTED ABOVE

WHEN RESPONDING TO RFQ, INSERT NAME AND ADDRESS IN SPACE ABOVE LABELED 'VENDOR'



State of West Virginia  
 Department of Administration  
 Purchasing Division  
 2019 Washington Street East  
 Post Office Box 50130  
 Charleston, WV 25305-0130

# Request for Quotation

RFQ NUMBER  
**DEFK8138**

PAGE  
**4**

ADDRESS CORRESPONDENCE TO ATTENTION OF  
**JOHN ABBOTT**  
**304-558-2544**

**RFQ COPY**

**TYPE NAME/ADDRESS HERE**  
 Hager Construction, LLC  
 5317 Cherry Lawn Drive  
 Huntington, WV 25705

**DIV ENGINEERING & FACILITIES**  
**UNITED STATES PROPERTY**  
**FISCAL OFFICE**  
**50 ARMORY ROAD**  
**BUCKHANNON, WV**  
**26201-8818**

DATE PRINTED	TERMS OF SALE	SHIP VIA	FOB	FREIGHT TERMS
12/02/2007				

BID OPENING DATE: **01/09/2008** BID OPENING TIME **01:30PM**

LINE	QUANTITY	UQP	CAT NO	ITEM NUMBER	UNIT PRICE	AMOUNT
<p>ACCEPTED ONLY IF THE COST OF DOMESTIC PRODUCTS IS FOUND TO BE UNREASONABLE. SUCH COST IS UNREASONABLE IF IT IS 20% OR MORE HIGHER THAN THE BID PRICE FOR FOREIGN MADE PRODUCTS. IF THE DOMESTIC ALUMINUM, GLASS OR STEEL PRODUCTS TO BE SUPPLIED OR PRODUCED IN A "SUBSTANTIAL LABOR SURPLUS AREA", AS DEFINED BY THE UNITED STATES DEPARTMENT OF LABOR, FOREIGN PRODUCTS MAY BE SUPPLIED ONLY IF DOMESTIC PRODUCTS ARE 30% OR MORE HIGHER IN PRICE THAN THE FOREIGN MADE PRODUCTS.</p> <p>IF, PRIOR TO THE AWARD OF A CONTRACT UNDER THE ABOVE PROVISIONS, THE SPENDING OFFICER OF THE SPENDING UNIT DETERMINES THAT THERE EXISTS A BID FOR LIKE FOREIGN ALUMINUM, GLASS OR STEEL THAT IS REASONABLE AND LOWER THAN THE LOWEST BID DOMESTIC PRODUCTS, THE SPENDING OFFICE MAY REQUEST, IN WRITING, A REEVALUATION AND REDUCTION IN THE LOWEST BID FOR SUCH DOMESTIC PRODUCTS. ALL VENDORS MUST INDICATE IN THEIR BID IF THEY ARE SUPPLYING FOREIGN ALUMINUM, GLASS OR STEEL.</p> <p>REV. 3/88</p> <p>EXHIBIT 9</p> <p>NOTICE FOR ISSUANCE &amp; ACKNOWLEDGEMENT OF CONSTRUCTION PROJECT ADDENDA</p> <p>THE ARCHITECT/ENGINEER AND/OR AGENCY SHALL BE REQUIRED TO ABIDE BY THE FOLLOWING SCHEDULE IN ISSUING CONSTRUCTION PROJECT ADDENDA FOR STATE AGENCIES:</p> <p>(1) THE ARCHITECT/ENGINEER SHALL PREPARE THE ADDENDUM AND A LIST OF ALL PARTIES THAT HAVE PROCURED DRAWINGS AND SPECIFICATIONS FOR THE PROJECT. THE ADDENDUM AND LIST SHALL BE FORWARDED TO THE BUYER IN THE STATE</p>						

SEE REVERSE SIDE FOR TERMS AND CONDITIONS

SIGNATURE <i>[Signature]</i>	TELEPHONE 304-302-7885	DATE 1/9/2008
TITLE Owner	FEIN 55-0772956	ADDRESS CHANGES TO BE NOTED ABOVE

WHEN RESPONDING TO RFQ, INSERT NAME AND ADDRESS IN SPACE ABOVE LABELED 'VENDOR'



State of West Virginia  
 Department of Administration  
 Purchasing Division  
 2019 Washington Street East  
 Post Office Box 50130  
 Charleston, WV 25305-0130

# Request for Quotation

RFQ NUMBER  
**DEFK8138**

PAGE  
**5**

ADDRESS CORRESPONDENCE TO ATTENTION OF:  
**JOHN ABBOTT**  
**304-558-2544**

VENDOR

**RFQ COPY**  
**TYPE NAME/ADDRESS HERE**

Hager Construction, LLC  
 5317 Cherry Lawn Drive  
 Huntington, WV 25705

SHIP TO

**DIV ENGINEERING & FACILITIES**  
**UNITED STATES PROPERTY**  
**FISCAL OFFICE**  
**50 ARMORY ROAD**  
**BUCKHANNON, WV**  
**26201-8818**

DATE PRINTED	TERMS OF SALE	SHIP VIA	F.O.B.	FREIGHT TERMS
12/02/2007				

BID OPENING DATE: **01/09/2008** BID OPENING TIME **01:30PM**

LINE	QUANTITY	UOP	CAT NO	ITEM NUMBER	UNIT PRICE	AMOUNT
<p>PURCHASING DIVISION. THE ARCHITECT/ENGINEER SHALL ALSO SEND A COPY OF THE ADDENDUM TO THE STATE AGENCY FOR WHICH THE CONTRACT IS ISSUED.</p> <p>(2) THE BUYER SHALL SEND THE ADDENDUM TO ALL INTERESTED PARTIES AND, IF NECESSARY, EXTEND THE BID OPENING DATE. ANY ADDENDUM SHOULD BE RECEIVED BY THE BUYER WITHIN FOURTEEN (14) DAYS PRIOR TO THE BID OPENING DATE.</p> <p>(3) ALL ADDENDA SHOULD BE FORMALLY ACKNOWLEDGED BY ALL BIDDERS AND SUBMITTED TO THE STATE PURCHASING DIVISION. THE SAME RULES AND REGULATIONS THAT APPLY TO THE ORIGINAL BIDDING DOCUMENT SHALL ALSO APPLY TO AN ADDENDUM DOCUMENT. THE ONLY EXCEPTION MAY BE FOR AN ADDENDUM THAT IS ISSUED FOR THE SOLE PURPOSE OF CHANGING A BID OPENING TIME AND/OR DATE.</p> <p>REV. 11/96</p> <p>EXHIBIT 10</p> <p>ADDENDUM ACKNOWLEDGEMENT</p> <p>I HEREBY ACKNOWLEDGE RECEIPT OF THE FOLLOWING CHECKED ADDENDUM(S) AND HAVE MADE THE NECESSARY REVISIONS TO MY PROPOSAL, PLANS AND/OR SPECIFICATION, ETC.</p> <p>ADDENDUM NOS.:</p> <p>NO. 1 .. 12/5/2007 .....</p> <p>NO. 2 .. 12/26/2007 .....</p>						

SEE REVERSE SIDE FOR TERMS AND CONDITIONS

SIGNATURE <i>R. Ang</i>	TELEPHONE 304-302-7885	DATE 1/9/2008
TITLE Owner	FEIN 55-0772956	ADDRESS CHANGES TO BE NOTED ABOVE

WHEN RESPONDING TO RFQ, INSERT NAME AND ADDRESS IN SPACE ABOVE LABELED 'VENDOR'



State of West Virginia  
 Department of Administration  
 Purchasing Division  
 2019 Washington Street East  
 Post Office Box 50130  
 Charleston, WV 25305-0130

# Request for Quotation

RFQ NUMBER  
**DEFK8138**

PAGE  
**6**

ADDRESS CORRESPONDENCE TO ATTENTION OF  
**JOHN ABBOTT**  
**304-558-2544**

**RFQ COPY**

**TYPE NAME/ADDRESS HERE**

Hager Construction, LLC  
 5317 Cherry Lawn Drive  
 Huntington, WV 25705

**DIV ENGINEERING & FACILITIES**  
**UNITED STATES PROPERTY**  
**FISCAL OFFICE**  
**50 ARMORY ROAD**  
**BUCKHANNON, WV**  
**26201-8818**

DATE PRINTED	TERMS OF SALE	SHIP VIA	F.O.B.	FREIGHT TERMS
12/02/2007				

BID OPENING DATE: **01/09/2008** BID OPENING TIME **01:30PM**

LINE	QUANTITY	UOP	CAT NO	ITEM NUMBER	UNIT PRICE	AMOUNT
	NO. 3	.....				
	NO. 4	.....				
	NO. 5	.....				
<p>I UNDERSTAND THAT FAILURE TO CONFIRM THE RECEIPT OF THE ADDENDUM(S) MAY BE CAUSE FOR REJECTION OF THE BIDS.</p> <p>VENDOR MUST CLEARLY UNDERSTAND THAT ANY VERBAL REPRESENTATION MADE OR ASSUMED TO BE MADE DURING ANY ORAL DISCUSSION HELD BETWEEN VENDOR'S REPRESENTATIVES AND ANY STATE PERSONNEL IS NOT BINDING. ONLY THE INFORMATION ISSUED IN WRITING AND ADDED TO THE SPECIFICATIONS BY AN OFFICIAL ADDENDUM IS BINDING.</p> <p>.....<i>R. Hager</i>.....SIGNATURE</p> <p>... Hager Construction, LLC .....COMPANY</p> <p>1/9/2008 .....DATE</p> <p>REV. 11/96</p> <p>CONTRACTORS LICENSE</p> <p>WEST VIRGINIA STATE CODE 21-11-2 REQUIRES THAT ALL PERSONS DESIRING TO PERFORM CONTRACTING WORK IN THIS STATE MUST BE LICENSED. THE WEST VIRGINIA CONTRACTORS LICENSING BOARD IS EMPOWERED TO ISSUE THE CONTRACTORS LICENSE. APPLICATIONS FOR A CONTRACTORS LICENSE MAY BE MADE BY CONTACTING THE WEST VIRGINIA DIVISION OF LABOR CAPITOL COMPLEX, BUILDING 3, ROOM 319, CHARLESTON, WV 25305. TELEPHONE: (304) 558-7890.</p>						

SEE REVERSE SIDE FOR TERMS AND CONDITIONS

SIGNATURE <i>R. Hager</i>	TELEPHONE 304-302-7885	DATE 1/9/2008
TITLE Owner	FEIN 55-0772956	ADDRESS CHANGES TO BE NOTED ABOVE

WHEN RESPONDING TO RFQ, INSERT NAME AND ADDRESS IN SPACE ABOVE LABELED 'VENDOR'



State of West Virginia  
 Department of Administration  
 Purchasing Division  
 2019 Washington Street East  
 Post Office Box 50130  
 Charleston, WV 25305-0130

# Request for Quotation

RFQ NUMBER  
**DEFK8138**

PAGE  
**7**

ADDRESS CORRESPONDENCE TO ATTENTION OF  
**JOHN ABBOTT**  
**304-558-2544**

**RFQ COPY**

**TYPE NAME/ADDRESS HERE**

Hager Construction, LLC  
 5317 Cherry Lawn Drive  
 Huntington, WV 25705

**DIV ENGINEERING & FACILITIES**  
**UNITED STATES PROPERTY**  
**FISCAL OFFICE**  
**50 ARMORY ROAD**  
**BUCKHANNON, WV**  
**26201-8818**

DATE PRINTED <b>12/02/2007</b>	TERMS OF SALE	SHIP VIA	F.O.B.	FREIGHT TERMS
-----------------------------------	---------------	----------	--------	---------------

BID OPENING DATE: **01/09/2008** BID OPENING TIME **01:30PM**

LINE	QUANTITY	UOP	CAT NO	ITEM NUMBER	UNIT PRICE	AMOUNT
<p>WEST VIRGINIA STATE CODE 21-11-11 REQUIRES ANY PROSPECTIVE BIDDER TO INCLUDE THE CONTRACTORS LICENSE NUMBER ON THEIR BID.</p> <p>BIDDER TO COMPLETE:</p> <p>CONTRACTORS NAME: ....Hager Construction, LLC.....</p> <p>CONTRACTORS LICENSE NO.: ..WV010261.....</p> <p>THE SUCCESSFUL BIDDER WILL BE REQUIRED TO FURNISH A COPY OF THEIR CONTRACTORS LICENSE PRIOR TO ISSUANCE OF A PURCHASE ORDER/CONTRACT</p> <p>APPLICABLE LAW</p> <p>THE WEST VIRGINIA STATE CODE, PURCHASING DIVISION RULE AND REGULATIONS, AND THE INFORMATION PROVIDED IN THE "REQUEST FOR QUOTATION" ISSUED BY THE PURCHASING DIVISION IS THE SOLE AUTHORITY GOVERNING THIS PROCUREMENT.</p> <p>ANY INFORMATION PROVIDED IN SPECIFICATION MANUALS, OR ANY OTHER SOURCE, VERBAL OR WRITTEN, WHICH CONTRADICTS OR ALTERS THE INFORMATION PROVIDED FROM THE SOURCES AS DESCRIBED IN THE ABOVE PARAGRAPH IS VOID AND OF NO EFFECT.</p> <p>BANKRUPTCY: IN THE EVENT THE VENDOR/CONTRACTOR FILES FOR BANKRUPTCY PROTECTION, THIS CONTRACT IS AUTOMATICALLY NULL AND VOID, AND IS TERMINATED WITHOUT FURTHER ORDER.</p> <p>REV. 1/2005</p>						

SEE REVERSE SIDE FOR TERMS AND CONDITIONS

SIGNATURE <i>R. Abbott</i>	TELEPHONE 304-302-7885	DATE 1/9/2008
TITLE Owner	FERN 55-0772956	ADDRESS CHANGES TO BE NOTED ABOVE

WHEN RESPONDING TO RFQ, INSERT NAME AND ADDRESS IN SPACE ABOVE LABELED 'VENDOR'





State of West Virginia  
 Department of Administration  
 Purchasing Division  
 2019 Washington Street East  
 Post Office Box 50130  
 Charleston, WV 25305-0130

# Request for Quotation

RFQ NUMBER  
**DEFK8138**

PAGE  
**8**

ADDRESS CORRESPONDENCE TO ATTENTION OF  
**JOHN ABBOTT**  
**304-558-2544**

**RFQ COPY**  
**TYPE NAME/ADDRESS HERE**

Hager Construction, LLC  
 5317 Cherry Lawn Drive  
 Huntington, WV 25705

**DIV ENGINEERING & FACILITIES**  
**UNITED STATES PROPERTY**  
**FISCAL OFFICE**  
**50 ARMORY ROAD**  
**BUCKHANNON, WV**  
**26201-8818**

DATE PRINTED	TERMS OF SALE	SHIP VIA	FOB	FREIGHT TERMS
12/02/2007				

BID OPENING DATE: **01/09/2008** BID OPENING TIME **01:30PM**

LINE	QUANTITY	UOP	CAT. NO.	ITEM NUMBER	UNIT PRICE	AMOUNT
<p><b>NOTICE</b></p> <p><b>A SIGNED BID MUST BE SUBMITTED TO:</b></p> <p><b>DEPARTMENT OF ADMINISTRATION</b>  <b>PURCHASING DIVISION</b>  <b>BUILDING 15</b>  <b>2019 WASHINGTON STREET, EAST</b>  <b>CHARLESTON, WV 25305-0130</b></p> <p><b>THE BID SHOULD CONTAIN THIS INFORMATION ON THE FACE OF THE ENVELOPE OR THE BID MAY NOT BE CONSIDERED:</b></p> <p><b>SEALED BID</b></p> <p><b>BUYER: JOHN ABBOTT-----</b></p> <p><b>REQ. NO.: DEFK8138-----</b></p> <p><b>BID OPENING DATE: 1/9/2008-----</b></p> <p><b>BID OPENING TIME: 1:30 PM-----</b></p> <p><b>PLEASE PROVIDE A FAX NUMBER IN CASE IT IS NECESSARY TO CONTACT YOU REGARDING YOUR BID:</b></p> <p style="text-align: center;">304-302-7895</p> <p><b>PLEASE PRINT OR TYPE NAME OF PERSON TO CONTACT CONCERNING THIS QUOTE:</b></p> <p style="text-align: center;">Sean Adkins</p>						

SEE REVERSE SIDE FOR TERMS AND CONDITIONS

SIGNATURE	TELEPHONE 304-302-7885	DATE 1/9/2008
TITLE Owner	FEIN 55-0772956	ADDRESS CHANGES TO BE NOTED ABOVE

WHEN RESPONDING TO RFQ, INSERT NAME AND ADDRESS IN SPACE ABOVE LABELED 'VENDOR'



State of West Virginia  
 Department of Administration  
 Purchasing Division  
 2019 Washington Street East  
 Post Office Box 50130  
 Charleston, WV 25305-0130

# Request for Quotation

RFQ NUMBER  
**DEFK8138**

PAGE  
**9**

ADDRESS CORRESPONDENCE TO ATTENTION OF  
**JOHN ABBOTT**  
**304-558-2544**

RFQ COPY

**TYPE NAME/ADDRESS HERE**  
 Hager Construction, LLC  
 5317 Cherry Lawn Drive  
 Huntington, WV 25705

SHIP TO

**DIV ENGINEERING & FACILITIES**  
**UNITED STATES PROPERTY**  
**FISCAL OFFICE**  
**50 ARMORY ROAD**  
**BUCKHANNON, WV**  
**26201-8818**

DATE PRINTED	TERMS OF SALE	SHIP VIA	FOB	FREIGHT TERMS
12/02/2007				

BID OPENING DATE: **01/09/2008** BID OPENING TIME **01:30PM**

LINE	QUANTITY	UOP	CAT NO	ITEM NUMBER	UNIT PRICE	AMOUNT
***** THIS IS THE END OF RFQ DEFK8138 ***** TOTAL:						SEE ATTACHED

SEE REVERSE SIDE FOR TERMS AND CONDITIONS

SIGNATURE <i>R. Abbott</i>	TELEPHONE 304-302-7885	DATE 1/9/2008
TITLE Owner	FAX 55-0772956	ADDRESS CHANGES TO BE NOTED ABOVE

WHEN RESPONDING TO RFQ, INSERT NAME AND ADDRESS IN SPACE ABOVE LABELED 'VENDOR'

Buyer: DEF	Page 10	Req. or P.O. No. DEFK8138
Spending Unit:		

Item No.	Quantity	Description	Unit Price	Amount
		<p><b>1.0 General Contract Information</b></p> <p>The scope of work for this project is to remove an existing vehicular exhaust removal system and provide and install a new updated vehicular exhaust removal system in the West Virginia Army National Guard's FMS #2 Shop in Buckhannon West Virginia. Contractor to provide an exhaust removal system that meets or exceeds any and all state and federal codes. The exhaust removal system shall be in compliance with all OSHA requirements.</p> <p>Contractor shall provide:</p> <p>a) Demolition and disposal of old exhaust system off site at contractor's expense.</p> <p>b) Provide all materials and labor to provide a complete project.</p> <p>c) Contractor to provide a drop in all 5 bays. Vehicular Exhaust Removal system must have the capability of removing idle speed exhaust simultaneously and continually. Furthermore bay 5 (see attached layout drawing below) must be able to remove exhaust at hydraulic load testing RPMs. <b>(NOTE: CONTRACTOR HAS THE RIGHT TO HAVE ALL 5 BAYS OPERATION CAPABILITY AT THE HYDRAULIC LOAD TESTING RPMs IF HE SO CHOOSES, BECAUSE OF COST OR OTHER CONSTRAINTS.)</b></p> <p>d) After the completion of the installation of the new vehicular exhaust removal system contractor is responsible for testing the system for operation and compliance, and forward these results to the West Virginia Army National Guard, Division of Engineering. These results should be sent to Attention Michael Beckner the Facilities Management Specialist.</p>		

Buyer:	Page	Req. or P.O. No.
DEF	11	DEFK8138
Spending Unit:		

Item No.	Quantity	Description	Unit Price	Amount
		<p><b>1.1 Design Restraints</b></p> <p>The Exhaust removal system needs to have hose adaptors that allow for 3 inch through 5 inch exhausts stacks, both vertical top stack and horizontal undercarriage stacks. The fan size for the new vehicular exhaust removal system shall be designed to accomodate up to the Military's Heavy Expanded Mobility Tactical Truck (HEMTT).</p> <p>HEMTT ENGINE SPECIFICATIONS are as follows:            Manufacture: Detroit Diesel Allison            Type: 736 cubic inch, 8 cylinder, 2-stroke, V-type Diesel            Rating: 450 horsepower, @ 2100 rpm</p> <p><b>1.2 COORDINATION OF TRADES</b></p> <p>Ductwork offsets, fittings, and any other accessories required shall be furnished to provide a complete exhaust system installation.</p> <p><b>1.3 DELIVERY AND STORAGE</b></p> <p>All equipment delivered and placed in storage shall be housed in a manner to preclude any damage from the weather, humidity and temperature variations, dirt and dust, or other contaminants. Additionally, all ductwork, flexible connections and pipes shall either be capped or plugged until installed.</p>		

Buyer:	Page	Req. or P.O. No.
DEF	12	DEFK8138
Spending Unit:		

Item No.	Quantity	Description	Unit Price	Amount
		<p><b>1.4 FIELD MEASUREMENTS</b></p> <p>The Contractor shall become familiar with all details of the work, verify all dimensions in the field, and shall advise the project manager of any discrepancy before performing the work. Measurements can be obtained at the mandatory pre-bid meeting.</p> <p><b>1.5 EXHAUST HOSE SYSTEM</b></p> <p>Exhaust Hose System shall be rated to with stand continuous run. In bays 1 through 4 this at idle speed only. In bay 5 the exhaust hose system shall be capable of withstand in hydraulic load testing RPMS. Exhaust hoses shall be have enough length as to accommodate both top stacks and under carriage stacks. <b>(NOTE: CONTRACTOR HAS THE RIGHT TO HAVE ALL 5 BAYS OPERATION CAPABILITYS AT THE HYDRAULIC LOAD TESTING RPMS IF HE SO CHOOSES, BECAUSE OF COST OR OTHER CONSTRAINTS.)</b></p> <p><b>1.6 Tailpipe Adapters</b></p> <p>Adapters shall be of the tapered-cone type with spring clips or other suitable devices for exhaust pipe attachment. The adapter shall fit 3 inch through 5 inch nominal diameter exhaust pipe.</p>		

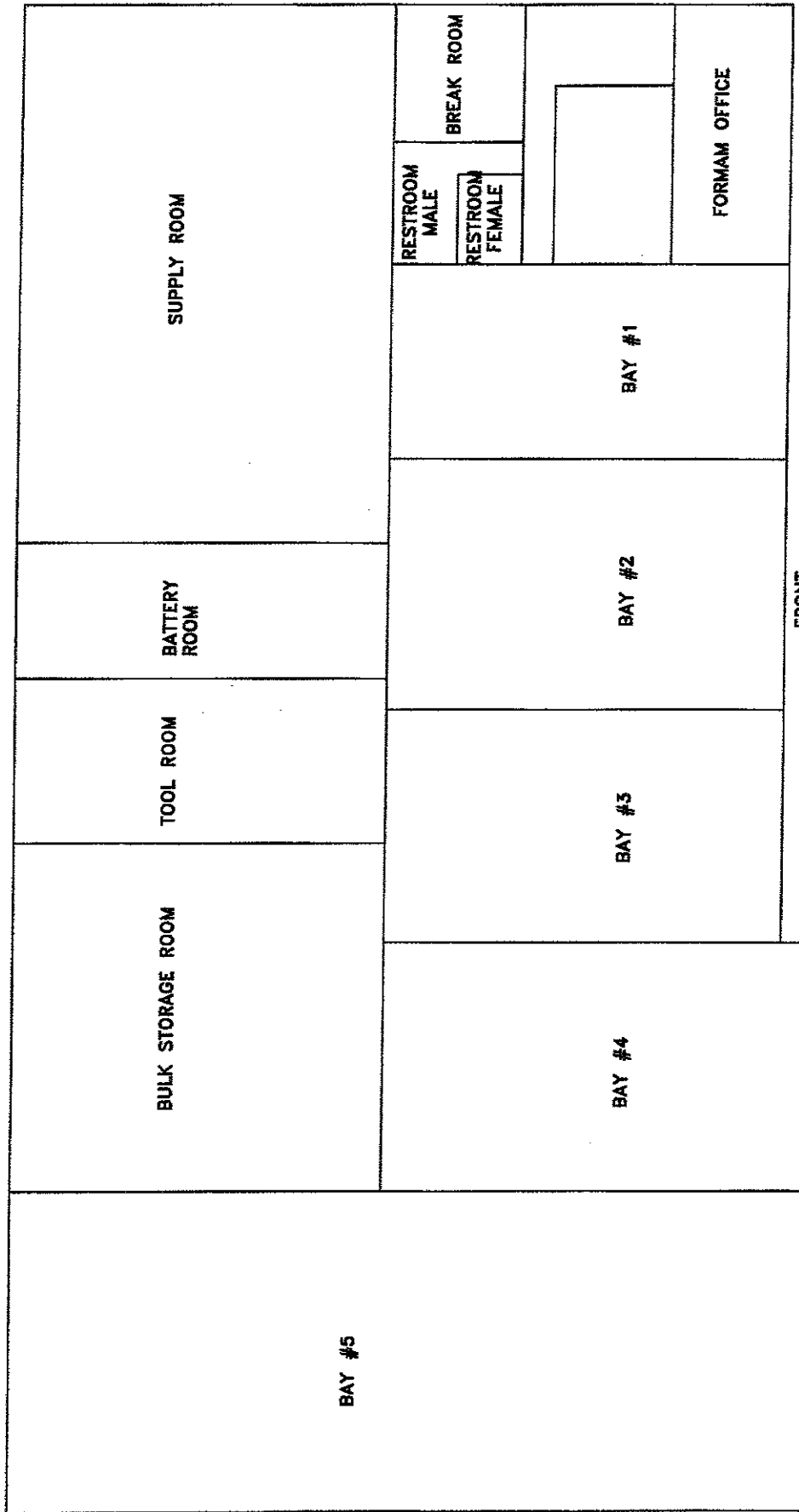

NOTE:  
DRAWING NOT TO SCALE

FRONT

WEST VIRGINIA ARMY NATIONAL GUARD

FMS #2 SHOP

BUCKHANNON, WEST VIRGINIA

BASIC BUILDING LAYOUT

STATE OF WEST VIRGINIA  
Purchasing Division**PURCHASING AFFIDAVIT**

**West Virginia Code §5A-3-10a states:** No contract or renewal of any contract may be awarded by the state or any of its political subdivisions to any vendor or prospective vendor when the vendor or prospective vendor or a related party to the vendor or prospective vendor is a debtor and the debt owed is an amount greater than one thousand dollars in the aggregate

**DEFINITIONS:**

"Debt" means any assessment, premium, penalty, fine, tax or other amount of money owed to the state or any of its political subdivisions because of a judgment, fine, permit violation, license assessment, defaulted workers' compensation premium, penalty or other assessment presently delinquent or due and required to be paid to the state or any of its political subdivisions, including any interest or additional penalties accrued thereon.

"Debtor" means any individual, corporation, partnership, association, limited liability company or any other form or business association owing a debt to the state or any of its political subdivisions. "Political subdivision" means any county commission; municipality; county board of education; any instrumentality established by a county or municipality; any separate corporation or instrumentality established by one or more counties or municipalities, as permitted by law; or any public body charged by law with the performance of a government function or whose jurisdiction is coextensive with one or more counties or municipalities. "Related party" means a party, whether an individual, corporation, partnership, association, limited liability company or any other form or business association or other entity whatsoever, related to any vendor by blood, marriage, ownership or contract through which the party has a relationship of ownership or other interest with the vendor so that the party will actually or by effect receive or control a portion of the benefit, profit or other consideration from performance of a vendor contract with the party receiving an amount that meets or exceeds five percent of the total contract amount.

**EXCEPTION:** The prohibition of this section does not apply where a vendor has contested any tax administered pursuant to chapter eleven of this code, workers' compensation premium, permit fee or environmental fee or assessment and the matter has not become final or where the vendor has entered into a payment plan or agreement and the vendor is not in default of any of the provisions of such plan or agreement.

**LICENSING:** Vendors must be licensed and in good standing in accordance with any and all state and local laws and requirements by any state or local agency of West Virginia, including, but not limited to, the West Virginia Secretary of State's Office, the West Virginia Tax Department, West Virginia Insurance Commission, or any other state agencies or political subdivision. Furthermore, the vendor must provide all necessary releases to obtain information to enable the Director or spending unit to verify that the vendor is licensed and in good standing with the above entities.

**CONFIDENTIALITY:** The vendor agrees that he or she will not disclose to anyone, directly or indirectly, any such personally identifiable information or other confidential information gained from the agency, unless the individual who is the subject of the information consents to the disclosure in writing or the disclosure is made pursuant to the agency's policies, procedures and rules. Vendors should visit [www.state.wv.us/admin/purchase/privacy](http://www.state.wv.us/admin/purchase/privacy) for the Notice of Agency Confidentiality Policies.

Under penalty of law for false swearing (West Virginia Code, §61-5-3), it is hereby certified that the vendor acknowledges the information in this said affidavit and are in compliance with the requirements as stated.

Vendor's Name: Hager Construction, LLC

Authorized Signature: 

Date: 1/9/2008

Buyer: DEF	Page 13	Req. or P.O. No. DEFK8138
Spending Unit:		

Item No.	Quantity	Description	Unit Price	Amount
		<p><b>1.7 Exhaust Hose Suspension System</b></p> <p>The exhaust hose suspension system shall suspend the flexible tubing overhead when not in use; allowing it to be lowered to the operating level, when required. The suspension system shall be furnished complete with cable, and operating mechanism. The suspension system shall be [Counter-weighted type] or [manually operated balancer type with safety ratchet lock or automatic brake having slip resistant hand grip].</p> <p><b>1.8 Electrical Work</b></p> <p>Contractor shall make all electrical connections on the new vehicular exhaust removal system to provide a working finished product. This includes but not limited to, wiring, conduit, switches, and junction boxes. Electric equipment, including wiring and motor efficiencies, shall be according to all state and federal laws and codes.</p> <p><b>1.9 Building Surface Penetrations</b></p> <p>Sleeves or framed openings shall be utilized where duct penetrates building surfaces. Penetrations shall be sealed. Closure collars shall be installed around the duct on both sides of the penetrated surface. Collars shall fit tight against the building surfaces and snugly around the duct.</p> <p>Cost \$ Base Bid \$30,738.00            (Thirty thousand seven hundred thirty eight dollars and zero cents.)</p> <p>Alternate #1 \$21,866.00            (Twenty one thousand eight hundred sixty six dollars and zero cents.)</p>		



---

# HAGER

CONSTRUCTION, LLC

5317 CHERRY LAWN DR  
HUNTINGTON, WV 25705  
304-302-7885 OFFICE  
304-302-7895 FAX

---

**DATE:** January 9, 2008

**PROPOSAL FOR:** Div Engineering & Facilities  
United States Property Fiscal Office  
50 Armory Road  
Buckhannon, WV 26201-8818

**ATTENTION:** John Abbott

**PROJECT SCOPE:** Hager Construction, LLC will provide and install a MagneGrip™ Diesel Exhaust Extraction System for the source capture removal of vehicle exhaust emissions. Our proposal includes the removal of an existing vehicle exhaust system.

**SYSTEM FEATURES:** The MagneGrip™ System is 100% American made. System shall consist of three hose reels and three dampered nozzles connected to a central fan. Two on/off switch assemblies will be supplied to turn the system on and off.

**EQUIPMENT, MATERIAL AND LABOR PRICE:**

**BASE BID FOR BAYS 4 & 5**

Three Drop MagneGrip™ Hose Reel Exhaust System with central fan.

Package Includes:

- (3) 500400-53 5"X30' Spring Hose reel with Dampered Nozzle
- (1) M363 5hp 3ph 2929cfm @ 8"sp AMCA#2 BI Fan
- (1) 500162-01 Inlet Plenum
- (1) 500162-02 Outlet Plenum
- (2) ON/Off Switch
- (1) 500057-12 12" Upblast Backdraft Damper
- (All) Rigid Spiral Duct, Lateral Connectors etc.
- (All) Labor needed to install above System

**BASE BID PRICE.....\$30,738.00**

**ALTERNATE BID #1 FOR BAYS 1, 2 & 3**

Three Drop MagneGrip™ Hose Reel Exhaust System with central fan.

Package Includes:

- (3) 500400-53 5"X30' Spring Hose reel with Dampered Nozzle
- (1) M363 3hp 3ph 1713cfm @ 8"sp AMCA#2 BI Fan
- (1) 500161-01 Inlet Plenum
- (1) 500161-02 Outlet Plenum
- (2) ON/Off Switch
- (1) 500057-10 10" Upblast Backdraft Damper
- (All) Rigid Spiral Duct, Lateral Connectors etc.
- (All) Labor needed to install above System

**ALTERNATE BID #1 PRICE .....\$21,866.00**

**TERMS:**

- < Includes: Electric Installation, from primary service panel source to Vehicle Exhaust Control Panel to Fan.  
It also includes fan disconnect and low voltage wiring if required.
  
- < Excludes: Any modifications to bring service to code. It excludes any booster, sub-panel or any additional electrical device to activate exhaust system. It excludes any architectural items such as painting of interior walls, gypsum wall board assemblies, repairs to gypsum wall board assemblies, repairs to CMU, etc.

**SUBMITTED BY:**

**ACCEPTED BY:**

Hager Construction, LLC

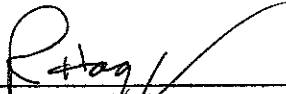
  
\_\_\_\_\_  
Ruford Hager, Jr.

Owner

Title

1/9/2008

Date

\_\_\_\_\_

\_\_\_\_\_

Title

Date

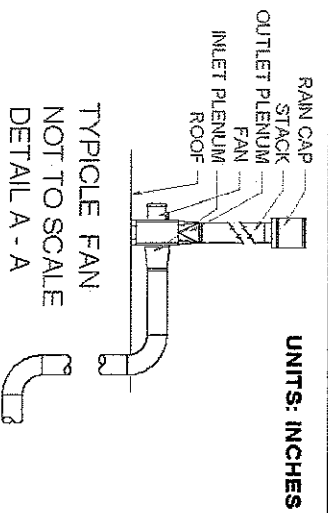
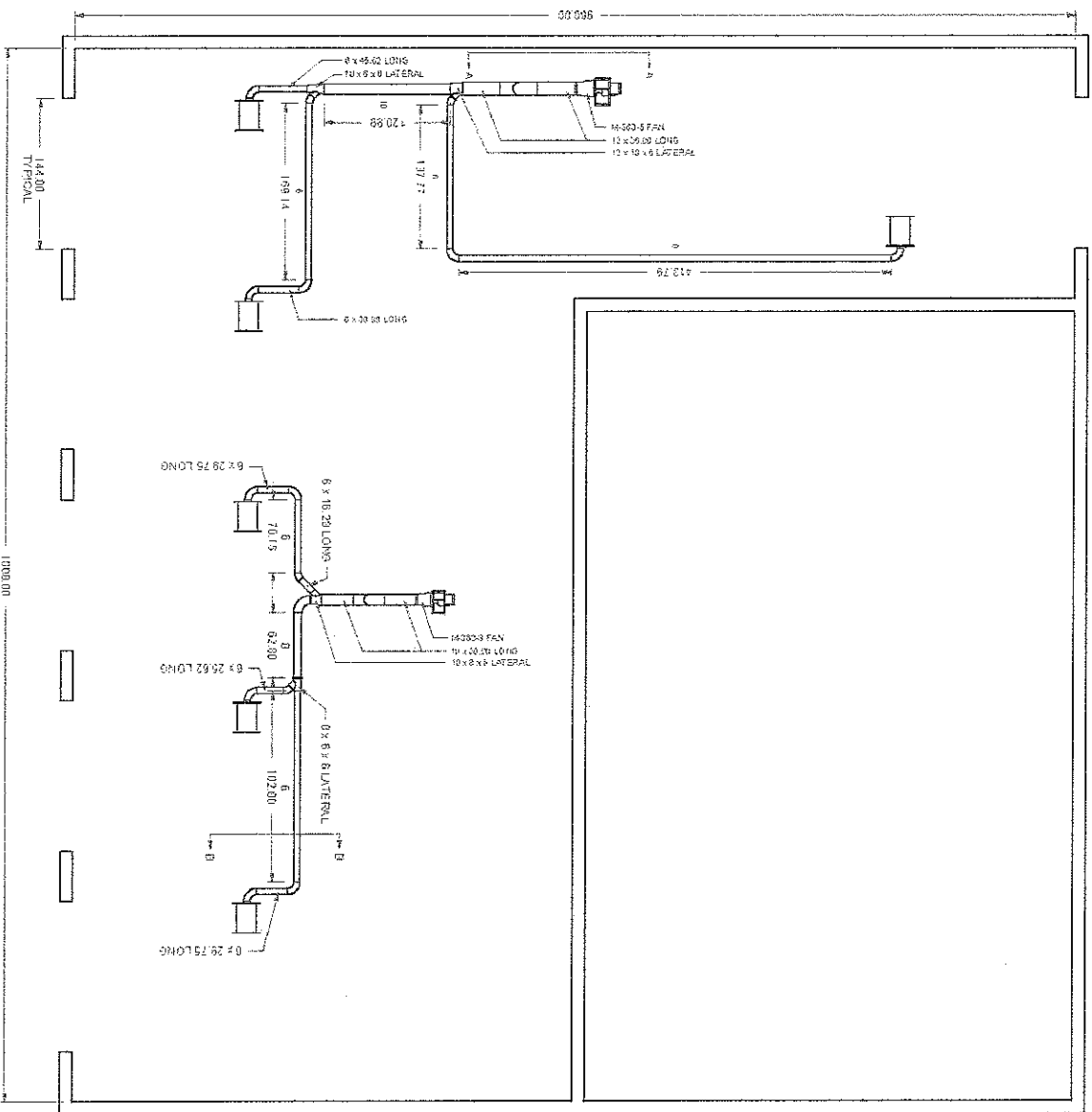

**BASIC HOSE REEL ILLUSTRATION  
NOT TO SCALE  
DETAIL B - B**

**NOTES:**

1. COORDINATE EXACT LOCATION OF EXHAUST FAN. RECOMMENDS QUALITY DUCTS WITH OWNER'S EQUIPMENT, LIGHTING AND ALL EXISTING CONDITIONS.
2. MANUFACTURE FAN FROM AN QUALITIES AND QUANTITY FURNISH QUANTITIES AS SPECIFIED FOR MANUFACTURE ON PERIODIC.
3. FOR DIMENSIONS OF CLEARANCE AND LOCATIONS OF EQUIPMENT ARE SHOWN TO SCALE WHEREAS POSSIBLE.
4. ALL WORK SHOWN IS NEW UNLESS INDICATED OTHERWISE.
5. ALL NEIGHBOR'S NOTES AND EQUIPMENT SHALL BE IN STRICT ACCORDANCE WITH THE BUILDING STANDARDS AS APPROVED BY THE OWNER.
6. ALL WORK SHALL BE IN ACCORDANCE WITH APPLICABLE STATE AND LOCAL CODES. CONTRACTOR SHALL SECURE AND PAY FOR HIS OWN PERMIT.
7. ALL DUCTWORK SHALL BE FABRICATED WITH SEAM DUCTWORK SHEET STEEL, FABRICATED AND INSTALLED IN ACCORDANCE WITH CHAPTER 9 (DUCTWORK) SPECIFICATION.
8. CONTRACTOR SHALL NOTIFY ALL EQUIPMENT IS STRICT ACCORDANCE WITH MANUFACTURER'S RECOMMENDATION.

**COMMENTS:**

- A. GET ALL NEW NOTED REPAIR. THE EXHAUST OF VEHICLE IN PARKING.
- B. CHECK ALL MATERIALS A "TYPICAL" REPAIR VIEW.
- C. CHECK IN THE PROCESS OF EXHAUST ILLUSTRATION HOW TO INSTALL AND TEST EQUIPMENT.

**FLOOR PLAN - DIESEL EXHAUST SYSTEM  
SCALE NOT NECESSARILY TO ANY SCALE  
FOR ILLUSTRATION PURPOSES ONLY**

**MagneGrip**  
Vehicle Exhaust Venting Systems

PROJECT: DIESEL EXHAUST SYSTEM  
BUCKWALDWIN, WY

REVISIONS:

SHEET TITLE: DIESEL EXHAUST SYSTEM - FLOOR PLAN

SHEET NO.: M-1

DATE: 1-7-08

DRAWN BY: [unreadable]

CHECKED BY: [unreadable]

CUSTOMER:
CUSTOMER PO:
PROJECT:
ENGINEER:
TAG:

Air flow :  
 HRM-4-25-HT: 250 CFM  
 HRM-4-33-HT: 250 CFM  
 HRM-5-25-HT: 400 CFM  
 HRM-5-33-HT: 400 CFM  
 HRM-6-25-HT: 600 CFM  
 HRM-6-33-HT: 600 CFM  
 HRM-8-25-HT: 1000 CFM  
 HRM-8-33-HT: 1000 CFM

Pressure drop over reel:  
 All hose reels: 4" w.g.

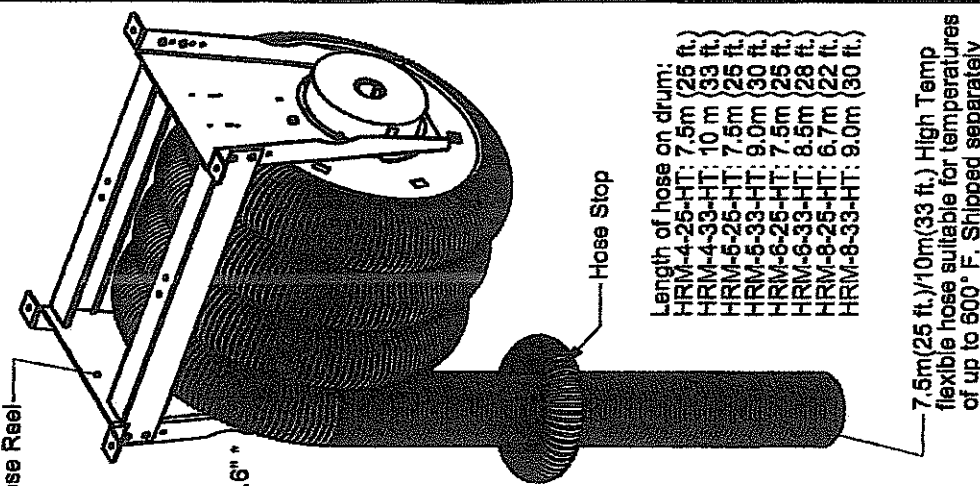

Length of hose on drum:  
 HRM-4-25-HT: 7.5m (25 ft.)  
 HRM-4-33-HT: 10 m (33 ft.)  
 HRM-5-25-HT: 7.5m (25 ft.)  
 HRM-5-33-HT: 9.0m (30 ft.)  
 HRM-6-25-HT: 7.5m (25 ft.)  
 HRM-6-33-HT: 8.5m (28 ft.)  
 HRM-8-25-HT: 6.7m (22 ft.)  
 HRM-8-33-HT: 9.0m (30 ft.)

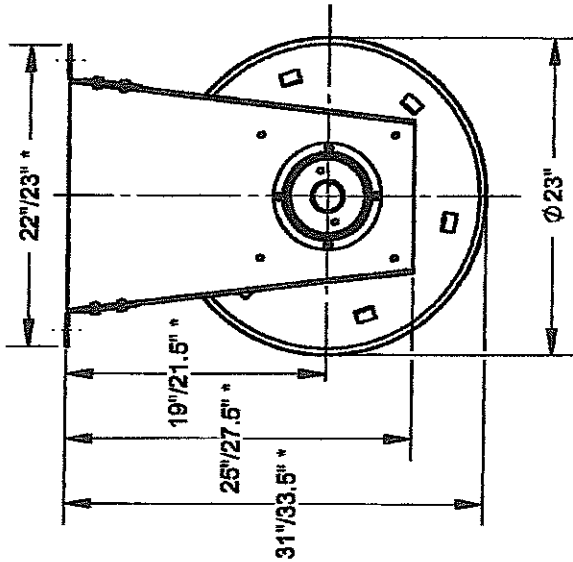
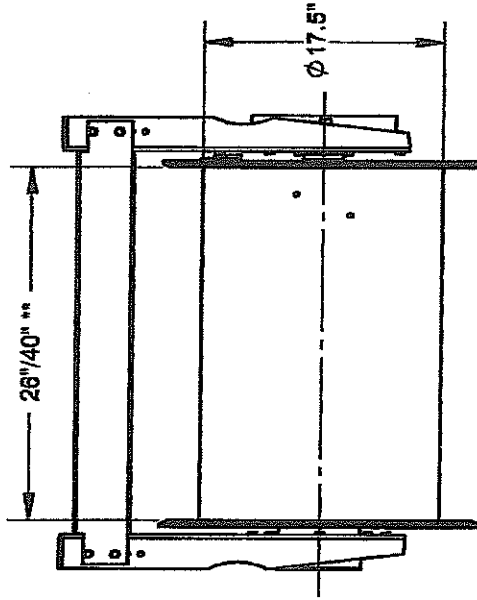
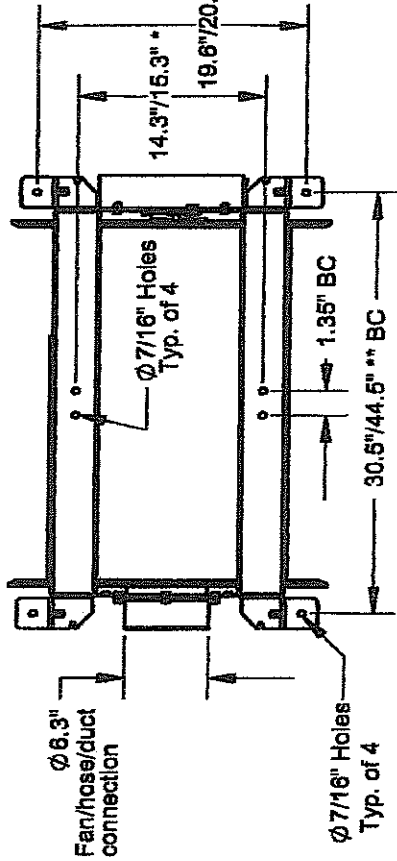

**MagneGrip**  
 HR Series Hose Reel

Drawn by: Asiften Pop  
 Date: 10/28/2004  
 Scale: NTS  
 Weight: 00.0



The devices depicted and described herein embody proprietary information owned by the manufacturer. All design, manufacturing, reproduction, sales and patent rights regarding this device or drawing reserved except where explicit right is guaranteed in writing. We reserve the right to make design changes.

**Spring Recoil Hose Reels**  
 Specification Drawing

Title:  
 Drawing No.: S-10120-00  
 File Name:  
 Material:  
 Sheet: 1/1

Note: The dimensions with \* are for HRM-8-25-HT  
 The dimensions with \*\* are for HRM-8-33-HT

# CAC - HOSE REEL Fan on/off Switch Technical Description

Clean Air Concepts  
1. 800. 875. 5440

Copyrighted

## SERIES DMSHR

### OPTIONAL DIRECT MOUNT FAN ON/OFF SWITCH

- |   |   |
|---|---|
| A - Sealed Mounting Box                       | E - Hose Reel Support Mounting Frame            |
| B - Box Cover Plate                           | F - On/Off Switch Control Assembly              |
| C - On/Off Toggle Switch **                   | G - Buffer Pad for Activating the On/Off Toggle |
| D - (2) Slot Cuts for Adjustment of Box Depth |   |

#### **ON/OFF SWITCH FUNCTION:**

The switch assembly is mounted to the support frame of the hose reel. The depth of the toggle is set to be semi-flush with the switch box. All other depth settings are set using the slotted holes in the switch box. The buffer pad is mounted to the end flange of the hose reel and tightened into place. With the toggle switch firmly in the box, the reel is turned so the buffer pad is directly in line with the switch. The final depth of the toggle box is now set so the buffer and toggle will make slight contact and the toggle arm is either turned on or off by the buffer pad.

The buffer pad is mounted to the end flange of the reel and turns with the reel as the hose is uncoiled or recoiled. As the hose is uncoiled the buffer pad triggers the toggle switch to the on position, thus completing an electrical circuit and the fan start-up begins. As the hose is recoiled, the buffer pad now triggers the toggle switch to the off position, thus disconnecting the electrical circuit. At this point "fan shut-down" occurs.

The switch is only used to complete the electrical circuit. The toggle switches are usually tied to a control box or a starter package for the blower that is in use. Toggle switches may be wired in parallel fashion to activate one central blower or the switches can be used to activate a single direct mount blower on the hose reel.

#### **\*\* SWITCH SPECIFICATIONS:**

**RATING:**  
15 AMP @ 125 VAC  
10 AMP @ 250 VAC  
3/4 HP @v 250 VAC

**CONFIDENTIAL USE BY AUTHORIZED DEALERS ONLY**

## CLEAN AIR CONCEPTS

11449 DEERFIELD ROAD, CINCINNATI, OHIO 45242 513-247-2502

### Blower/Motor Submittal Data

<b>Project</b>		<b>City, State</b>	
<b>Address</b>		<b>Station #</b>	

### Design Data

Blower Data		Motor Data	
Model	M363-5	Motor H.P.	5
Serial No.		Motor Speed	3450
Fan Class	2	Mfg / Frame size	WEG / 184-T
Rotation	Clockwise	Phase/Cycle/Volts	3/60/208/230/460
Discharge	Vert./Top Horz./Bot Horz.	Motor Enclosure	TEFC
Wheel Design	Backwardly Inclined	Full Load Amps.	5.9 @ 460 Volts
AMCA Class	B	Service Factor	1.25
Wheel Material	Aluminum	Class (Insulation)	F
Bore Size	1.125	Temp. Rise	80 C
Total ACFM		Full Load Eff.	88%
Total S.P.		Power Factor	90
Inlet Size		NEMA Code	B
Outlet Size		Thermal Prot.	No
Temp.(F)/Density		Motor Weight	110 lbs
Housing Material	Steel	Blower/Motor Wt.	237 lbs

## CLEAN AIR CONCEPTS

11449 DEERFIELD ROAD, CINCINNATI, OHIO 45242 513-247-2502

### Blower/Motor Submittal Data

<b>Project</b>		<b>City, State</b>	
<b>Address</b>		<b>Station #</b>	

### Design Data

Blower Data		Motor Data	
Model	M363-3	Motor H.P.	3
Serial No.		Motor Speed	3450
Fan Class	2	Mfg / Frame size	WEG / 182-T
Rotation	Clockwise	Phase/Cycle/Volts	3/60/208/230/460
Discharge	Vert./Top Horz./Bot Horz.	Motor Enclosure	TEFC
Wheel Design	Backwardly Inclined	Full Load Amps.	3.59 @ 460 Volts
AMCA Class	B	Service Factor	1.25
Wheel Material	Aluminum	Class (Insulation)	F
Bore Size	1.125	Temp. Rise	80 C
Total ACFM		Full Load Eff.	86%
Total S.P.		Power Factor	90
Inlet Size		NEMA Code	B
Outlet Size		Thermal Prot.	No
Temp.(F)/Density		Motor Weight	102 lbs
Housing Material	Steel	Blower/Motor Wt.	215 lbs

## MagneGrip New M-36 Series BI Exhaust Blowers

Model & HP	4" S.P.		5" S.P.		6" S.P.		7" S.P.		8" S.P.		9" S.P.		10" S.P.		11" S.P.		12" S.P.		13" S.P.		14" S.P.		15" S.P.	
	CFM	BHP	CFM	BHP	CFM	BHP	CFM	BHP	CFM	BHP	CFM	BHP	CFM	BHP	CFM	BHP	CFM	BHP	CFM	BHP	CFM	BHP	CFM	BHP
M-36-1.5	1386	1.4	1217	1.5	988	1.5																		
M-36-2	1881	1.9	1652	2.1	1340	2.1																		
M-36-3	2405	2.7	2225	2.9	1997	2.9	1713	2.9	1141	2.6														
M-36-5	3858	4.8	3614	4.9	3391	5.1	3180	5.1	2929	5.1	2649	5.1	2173	4.9										
M-36-7.5	4832	6.9	4574	7.1	4337	7.2	4119	7.3	3911	7.4	3696	7.4	3443	7.5	3170	7.5	2778	7.4						
M-36-10	6100	8.8	5782	9.1	5486	9.2	5212	9.3	4951	9.4	4693	9.5	4382	9.6	4046	9.6	3611	9.5						
M-36-15	7296	12	7154	12.8	7016	13.3	6879	14	6724	14	6541	15	6313	15	6049	15	5775	14.9						
M-36-20	9120	16	8942	16.1	8770	16.7	8598	17	8405	18	8176	18	7891	18	7661	19	7219	18.6						
M-36-25	9807	20	9651	20.1	9496	20.7	9342	21	9198	22	9041	23	8865	23	8662	24	8419	23.7						

All Fans available with or without inlet flanges, mild steel housing with inlet venturi and painted finish and TEFC motors  
 Fans are arrangement #4 direct drive, with Teflon shaft seals, AMCA "B" spark resistant construction and made in the USA

Special arrangements to meet specific CFM requirements are available, additional charges may apply.



**Clean Air Concepts  
DAMPERED NOZZLE  
ASSEMBLY**

Clean Air Concepts  
1. 800. 875. 5440

APPROVED BY D.R.

Feb. 2003

**SUBMITTAL**



**Made from galvanized 20 gauge steel damper nozzle is designed to close 90 to 95% Designed with a spring handle door, comes with or without handle.**

**Available in 3 sizes, 4" 5" and 6" also stainless steel if required.**

**CONFIDENTIAL USE BY AUTHORIZED DISTRIBUTORS OR CUSTOMERS ONLY**

# MagneGrip HI-TEMPERATURE HOSE

Clean Air Concepts  
1. 800. 875. 5440

APPROVED BY D R

Feb. 2003

## HIGH TEMPERATURE HOSE

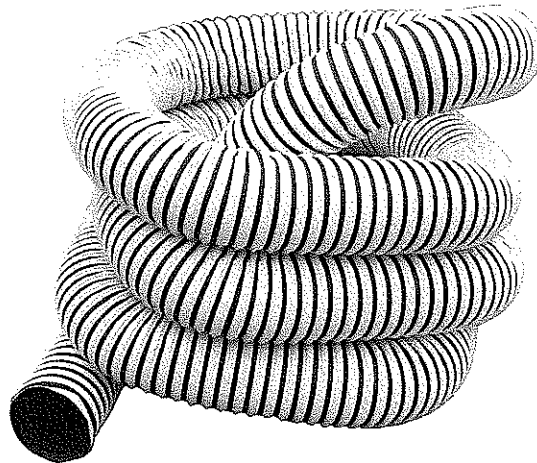

- HOSE SHALL BE HIGH TEMPERATURE DOUBLE PLY, ACRYLIC-COATED, POLYESTER, BLUE FABRIC CONSTRUCTION WITH A CONTINUOUS OPERATING RANGE OF 400 DEGREES (F) AND INTERMITTENT TEMPERATURE OF 550 DEGREES (F) AND LISTED AS UL94 V-O FLAME RETARDANT MATERIAL.
- HOSE SHALL INCORPORATE A 3/4" BOUND SPRING STEEL WIRE HELIX. A WEAR STRIP, WHITE IN COLOR AND 9/16" WIDE, SHALL COVER THE WIRE HELIX TO FURTHER PROTECT FROM HEAT BUILDUP.
- HOSE SHALL BE BRIGHT BLUE AND WHITE TO PROVIDE INCREASED VISIBILITY AND SAFETY TO ALL PERSONNEL.
- HOSE SHALL BE AVAILABLE IN SIZES 4, 5 AND 6 IN. STANDARD LENGTHS 23 AND 40 FEET.

CONFIDENTIAL USE BY AUTHORIZED DISTRIBUTORS OR CUSTOMERS ONLY

**BID BOND**

KNOW ALL MEN BY THESE PRESENTS, That we, the undersigned, Hager Construction, LLC  
of Huntington, WV, as Principal, and First National Insurance Company of  
America of Seattle, WA, a corporation organized and existing under the laws of the State of \_\_\_\_\_  
WA with its principal office in the City of Seattle, as Surety, are held and firmly bound unto the State  
of West Virginia, as Obligee, in the penal sum of Five Percent of Amount Bid (\$ 5%) for the payment of which,  
well and truly to be made, we jointly and severally bind ourselves, our heirs, administrators, executors, successors and assigns.

The Condition of the above obligation is such that whereas the Principal has submitted to the Purchasing Section of the  
Department of Administration a certain bid or proposal, attached hereto and made a part hereof, to enter into a contract in writing for  
RFQ #DEFK8138 Installation of a Vehicular Exhaust Removal System in the National Guard - According to Plans &  
Specifications

NOW THEREFORE,

- (a) If said bid shall be rejected, or
- (b) If said bid shall be accepted and the Principal shall enter into a contract in accordance with the bid or proposal attached  
hereto and shall furnish any other bonds and insurance required by the bid or proposal, and shall in all other respects perform the  
agreement created by the acceptance of said bid, then this obligation shall be null and void, otherwise this obligation shall remain in full  
force and effect. It is expressly understood and agreed that the liability of the Surety for any and all claims hereunder shall, in no event,  
exceed the penal amount of this obligation as herein stated.

The Surety, for the value received, hereby stipulates and agrees that the obligations of said Surety and its bond shall be in no  
way impaired or affected by any extension of the time within which the Obligee may accept such bid, and said Surety does hereby  
waive notice of any such extension.

IN WITNESS WHEREOF, Principal and Surety have hereunto set their hands and seals, and such of them as are corporations  
have caused their corporate seals to be affixed hereunto and these presents to be signed by their proper officers, this  
9th day of January, 2008.

Principal Corporate Seal

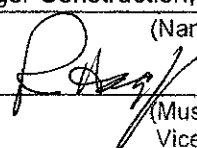
Hager Construction, LLC  
(Name of Principal)  
By:   
(Must be President or  
Vice President)  
Owner  
(Title)

Surety Corporate Seal

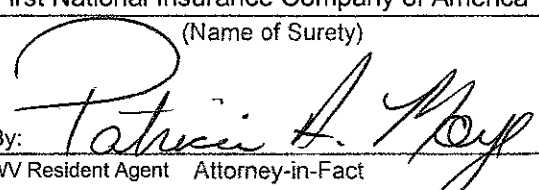
First National Insurance Company of America  
(Name of Surety)  
By:   
Patricia A. Moyer, WV Resident Agent Attorney-in-Fact

IMPORTANT – Surety executing bonds must be licensed in West Virginia to transact surety insurance. Corporate seals must be affixed,  
and a power of attorney must be attached.



POWER OF ATTORNEY

First National Insurance Company of America  
Safeco Plaza  
Seattle, WA 98185

No. 10372

KNOW ALL BY THESE PRESENTS:

That **FIRST NATIONAL INSURANCE COMPANY OF AMERICA**, a Washington corporation, does hereby appoint  
\*\*\*\*\*PATRICIA A. FINCKE; GREGORY T. GORDON; LARRY D. KERR; ALLAN L. MCVEY; PATRICIA A. MOYE;  
KIMBERLY J. WILKINSON; Charleston, West Virginia\*\*\*\*\*

its true and lawful attorney(s)-in-fact, with full authority to execute on behalf of the company fidelity and surety bonds or undertakings and other documents of a similar character issued by the company in the course of its business, and to bind **FIRST NATIONAL INSURANCE COMPANY OF AMERICA** thereby as fully as if such instruments had been duly executed by its regularly elected officers at its home office.

IN WITNESS WHEREOF, **FIRST NATIONAL INSURANCE COMPANY OF AMERICA** has executed and attested these presents

this 19th day of July, 2007

STEPHANIE DALEY-WATSON, SECRETARY

TIM MIKOLAJEWSKI, SENIOR VICE-PRESIDENT, SURETY

CERTIFICATE

Extract from the By-Laws of **FIRST NATIONAL INSURANCE COMPANY OF AMERICA**:

"Article V, Section 13. - FIDELITY AND SURETY BONDS ... the President, any Vice President, the Secretary, and any Assistant Vice President appointed for that purpose by the officer in charge of surety operations, shall each have authority to appoint individuals as attorneys-in-fact or under other appropriate titles with authority to execute on behalf of the company fidelity and surety bonds and other documents of similar character issued by the company in the course of its business... On any instrument making or evidencing such appointment, the signatures may be affixed by facsimile. On any instrument conferring such authority or on any bond or undertaking of the company, the seal, or a facsimile thereof, may be impressed or affixed or in any other manner reproduced; provided, however, that the seal shall not be necessary to the validity of any such instrument or undertaking."

Extract from a Resolution of the Board of Directors of  
**FIRST NATIONAL INSURANCE COMPANY OF AMERICA** adopted July 28, 1970.

"On any certificate executed by the Secretary or an assistant secretary of the Company setting out,

- (i) The provisions of Article V, Section 13 of the By-Laws, and
- (ii) A copy of the power-of-attorney appointment, executed pursuant thereto, and
- (iii) Certifying that said power-of-attorney appointment is in full force and effect,

the signature of the certifying officer may be by facsimile, and the seal of the Company may be a facsimile thereof."

I, Stephanie Daley-Watson, Secretary of **FIRST NATIONAL INSURANCE COMPANY OF AMERICA**, do hereby certify that the foregoing extracts of the By-Laws and of a Resolution of the Board of Directors of this corporation, and of a Power of Attorney issued pursuant thereto, are true and correct, and that both the By-Laws, the Resolution and the Power of Attorney are still in full force and effect.

IN WITNESS WHEREOF, I have hereunto set my hand and affixed the facsimile seal of said corporation

this 9th day of January, 2008



STEPHANIE DALEY-WATSON, SECRETARY

**BID BOND**

KNOW ALL MEN BY THESE PRESENTS, That we, the undersigned, Hager Construction, LLC  
\_\_\_\_\_ of Huntington \_\_\_\_\_, WV \_\_\_\_\_, as Principal, and First National Insurance Company of  
America of Seattle \_\_\_\_\_, WA \_\_\_\_\_, a corporation organized and existing under the laws of the State of \_\_\_\_\_  
WA \_\_\_\_\_ with its principal office in the City of Seattle \_\_\_\_\_, as Surety, are held and firmly bound unto the State  
of West Virginia, as Obligee, in the penal sum of Five Percent of Amount Bid (\$ \_\_\_\_\_ 5% \_\_\_\_\_) for the payment of which,  
well and truly to be made, we jointly and severally bind ourselves, our heirs, administrators, executors, successors and assigns.

The Condition of the above obligation is such that whereas the Principal has submitted to the Purchasing Section of the  
Department of Administration a certain bid or proposal, attached hereto and made a part hereof, to enter into a contract in writing for  
RFQ #DEFK8138 Installation of a Vehicular Exhaust Removal System in the National Guard - According to Plans &  
Specifications  
\_\_\_\_\_

NOW THEREFORE,

- (a) If said bid shall be rejected, or
- (b) If said bid shall be accepted and the Principal shall enter into a contract in accordance with the bid or proposal attached  
hereto and shall furnish any other bonds and insurance required by the bid or proposal, and shall in all other respects perform the  
agreement created by the acceptance of said bid, then this obligation shall be null and void, otherwise this obligation shall remain in full  
force and effect. It is expressly understood and agreed that the liability of the Surety for any and all claims hereunder shall, in no event,  
exceed the penal amount of this obligation as herein stated.

The Surety, for the value received, hereby stipulates and agrees that the obligations of said Surety and its bond shall be in no  
way impaired or affected by any extension of the time within which the Obligee may accept such bid, and said Surety does hereby  
waive notice of any such extension.

IN WITNESS WHEREOF, Principal and Surety have hereunto set their hands and seals, and such of them as are corporations  
have caused their corporate seals to be affixed hereunto and these presents to be signed by their proper officers, this  
9th day of January \_\_\_\_\_, 2008 \_\_\_\_\_.

Principal Corporate Seal

Hager Construction, LLC  
\_\_\_\_\_  
(Name of Principal)  
By: [Signature]  
\_\_\_\_\_  
(Must be President or  
Vice President)  
\_\_\_\_\_  
Owner  
\_\_\_\_\_  
(Title)

Surety Corporate Seal

First National Insurance Company of America  
\_\_\_\_\_  
(Name of Surety)  
By: [Signature]  
\_\_\_\_\_  
Patricia A. Moye, WV Resident Agent Attorney-in-Fact



POWER OF ATTORNEY

First National Insurance Company of America  
Safeco Plaza  
Seattle, WA 98185

No. 10372

KNOW ALL BY THESE PRESENTS:

That **FIRST NATIONAL INSURANCE COMPANY OF AMERICA**, a Washington corporation, does hereby appoint  
\*\*\*\*\*PATRICIA A. FINCKE; GREGORY T. GORDON; LARRY D. KERR; ALLAN L. MCVEY; PATRICIA A. MOYE;  
KIMBERLY J. WILKINSON; Charleston, West Virginia\*\*\*\*\*

its true and lawful attorney(s)-in-fact, with full authority to execute on behalf of the company fidelity and surety bonds or undertakings and other documents of a similar character issued by the company in the course of its business, and to bind **FIRST NATIONAL INSURANCE COMPANY OF AMERICA** thereby as fully as if such instruments had been duly executed by its regularly elected officers at its home office.

IN WITNESS WHEREOF, **FIRST NATIONAL INSURANCE COMPANY OF AMERICA** has executed and attested these presents

this 19th day of July, 2007

STEPHANIE DALEY-WATSON, SECRETARY

TIM MIKOLAJEWSKI, SENIOR VICE-PRESIDENT, SURETY

CERTIFICATE

Extract from the By-Laws of **FIRST NATIONAL INSURANCE COMPANY OF AMERICA**:

"Article V, Section 13. - FIDELITY AND SURETY BONDS ... the President, any Vice President, the Secretary, and any Assistant Vice President appointed for that purpose by the officer in charge of surety operations, shall each have authority to appoint individuals as attorneys-in-fact or under other appropriate titles with authority to execute on behalf of the company fidelity and surety bonds and other documents of similar character issued by the company in the course of its business... On any instrument making or evidencing such appointment, the signatures may be affixed by facsimile. On any instrument conferring such authority or on any bond or undertaking of the company, the seal, or a facsimile thereof, may be impressed or affixed or in any other manner reproduced; provided, however, that the seal shall not be necessary to the validity of any such instrument or undertaking."

Extract from a Resolution of the Board of Directors of **FIRST NATIONAL INSURANCE COMPANY OF AMERICA** adopted July 28, 1970.

"On any certificate executed by the Secretary or an assistant secretary of the Company setting out,

- (i) The provisions of Article V, Section 13 of the By-Laws, and
- (ii) A copy of the power-of-attorney appointment, executed pursuant thereto, and
- (iii) Certifying that said power-of-attorney appointment is in full force and effect,

the signature of the certifying officer may be by facsimile, and the seal of the Company may be a facsimile thereof."

I, Stephanie Daley-Watson, Secretary of **FIRST NATIONAL INSURANCE COMPANY OF AMERICA**, do hereby certify that the foregoing extracts of the By-Laws and of a Resolution of the Board of Directors of this corporation, and of a Power of Attorney issued pursuant thereto, are true and correct, and that both the By-Laws, the Resolution and the Power of Attorney are still in full force and effect.

IN WITNESS WHEREOF, I have hereunto set my hand and affixed the facsimile seal of said corporation

this 9th day of January, 2007



STEPHANIE DALEY-WATSON, SECRETARY

# CONTRACTOR LICENSE

Authorized by the

**West Virginia Contractor Licensing Board**

**Number:** WV010261

**Classification:**

GENERAL BUILDING  
MULTIFAMILY  
PLUMBING  
RESIDENTIAL  
SPECIALTY  
EXCAVATION  
DRYWALL  
MASONRY  
SIDING

ROOFING  
CONCRETE

HAGER CONSTRUCTION LLC  
5317 CHERRY LAWN DRIVE  
HUNTINGTON, WV 25705

**Date Issued**

**Expiration Date**

SEPTEMBER 10, 2007

SEPTEMBER 10, 2008

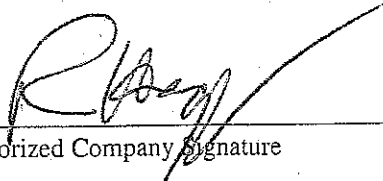
  
Authorized Company Signature

  
Chair, West Virginia Contractor  
Licensing Board



**WEST VIRGINIA  
CONTRACTOR  
LICENSING  
BOARD**

This license, or a copy thereof, must be posted in a conspicuous place at every construction site where work is being performed. This license number must appear in all advertisements, on all bid submissions and on all fully executed and binding contracts. This license cannot be assigned or transferred by licensee. Issued under provisions of West Virginia Code, Chapter 21, Article 11.

# ACORD CERTIFICATE OF LIABILITY INSURANCE

OP ID L.S.  
HAGER-1

DATE (MM/DD/YYYY)  
12/03/07

<b>PRODUCER</b>  United Security Agency 103 8th Avenue Huntington WV 25701 Phone: 304-525-6600 Fax: 304-525-7028	THIS CERTIFICATE IS ISSUED AS A MATTER OF INFORMATION ONLY AND CONFERS NO RIGHTS UPON THE CERTIFICATE HOLDER. THIS CERTIFICATE DOES NOT AMEND, EXTEND OR ALTER THE COVERAGE AFFORDED BY THE POLICIES BELOW.	
	<b>INSURERS AFFORDING COVERAGE</b>	<b>NAIC #</b>
<b>INSURED</b>  HAGER CONSTRUCTION LLC 5317 CHERRY LAWN DR. HUNTINGTON WV 25705	INSURER A: MOTORISTS MUTUAL INSURANCE CO	14621
	INSURER B:	
	INSURER C:	
	INSURER D:	
	INSURER E:	

RECEIVED DEC 04 2007

## COVERAGES

THE POLICIES OF INSURANCE LISTED BELOW HAVE BEEN ISSUED TO THE INSURED NAMED ABOVE FOR THE POLICY PERIOD INDICATED. NOTWITHSTANDING ANY REQUIREMENT, TERM OR CONDITION OF ANY CONTRACT OR OTHER DOCUMENT WITH RESPECT TO WHICH THIS CERTIFICATE MAY BE ISSUED OR MAY PERTAIN, THE INSURANCE AFFORDED BY THE POLICIES DESCRIBED HEREIN IS SUBJECT TO ALL THE TERMS, EXCLUSIONS AND CONDITIONS OF SUCH POLICIES. AGGREGATE LIMITS SHOWN MAY HAVE BEEN REDUCED BY PAID CLAIMS.

INSR ADD'L LTR INSR	TYPE OF INSURANCE	POLICY NUMBER	POLICY EFFECTIVE DATE (MM/DD/YY)	POLICY EXPIRATION DATE (MM/DD/YY)	LIMITS	
A	GENERAL LIABILITY	3326832740	12/01/07	12/01/08	EACH OCCURRENCE	\$ 1,000,000
	<input checked="" type="checkbox"/> COMMERCIAL GENERAL LIABILITY				DAMAGE TO RENTED PREMISES (Ea occurrence)	\$ 100,000
	<input type="checkbox"/> CLAIMS MADE <input checked="" type="checkbox"/> OCCUR				MED EXP (Any one person)	\$ 5,000
					PERSONAL & ADV INJURY	\$ 1,000,000
					GENERAL AGGREGATE	\$ 2,000,000
					PRODUCTS - COMP/OP AGG	\$ 2,000,000
					GEN'L AGGREGATE LIMIT APPLIES PER: <input type="checkbox"/> POLICY <input checked="" type="checkbox"/> PRO-JECT <input type="checkbox"/> LOC	
A	AUTOMOBILE LIABILITY	3326832740	12/01/07	12/01/08	COMBINED SINGLE LIMIT (Ea accident)	\$ 1,000,000
	<input checked="" type="checkbox"/> ANY AUTO				BODILY INJURY (Per person)	\$
	<input type="checkbox"/> ALL OWNED AUTOS				BODILY INJURY (Per accident)	\$
	<input type="checkbox"/> SCHEDULED AUTOS				PROPERTY DAMAGE (Per accident)	\$
	<input checked="" type="checkbox"/> HIRED AUTOS					
	<input checked="" type="checkbox"/> NON-OWNED AUTOS					
	GARAGE LIABILITY				AUTO ONLY - EA ACCIDENT \$	
	<input type="checkbox"/> ANY AUTO				OTHER THAN EA ACC \$	
					AUTO ONLY: AGG \$	
A	EXCESS/UMBRELLA LIABILITY	3326832740	12/01/07	12/01/08	EACH OCCURRENCE	\$ 3,000,000
	<input checked="" type="checkbox"/> OCCUR <input type="checkbox"/> CLAIMS MADE				AGGREGATE	\$ 3,000,000
	<input type="checkbox"/> DEDUCTIBLE					\$
	RETENTION \$					\$
A	WORKERS COMPENSATION AND EMPLOYERS' LIABILITY	3326832740	12/01/07	12/01/08	WC STATUTORY LIMITS	OTHER
	ANY PROPRIETOR/PARTNER/EXECUTIVE OFFICER/MEMBER EXCLUDED?				E.L. EACH ACCIDENT	\$ 1,000,000
	If yes, describe under SPECIAL PROVISIONS below				E.L. DISEASE - EA EMPLOYEE	\$ 1,000,000
					E.L. DISEASE - POLICY LIMIT	\$ 1,000,000
	OTHER					

DESCRIPTION OF OPERATIONS / LOCATIONS / VEHICLES / EXCLUSIONS ADDED BY ENDORSEMENT / SPECIAL PROVISIONS

## CERTIFICATE HOLDER

## CANCELLATION

CITYHU1  CITY OF HUNTINGTON P.O. BOX 1659 HUNTINGTON WV 25717-1659	SHOULD ANY OF THE ABOVE DESCRIBED POLICIES BE CANCELLED BEFORE THE EXPIRATION DATE THEREOF, THE ISSUING INSURER WILL ENDEAVOR TO MAIL _____ DAYS WRITTEN NOTICE TO THE CERTIFICATE HOLDER NAMED TO THE LEFT, BUT FAILURE TO DO SO SHALL IMPOSE NO OBLIGATION OR LIABILITY OF ANY KIND UPON THE INSURER, ITS AGENTS OR REPRESENTATIVES.  AUTHORIZED REPRESENTATIVE Vance Bunn
--	---





**PRODUCER:**

BrickStreet Mutual Insurance Company  
4700 MacCorkle Ave., S.E.  
Charleston, WV 25304

**CERTIFICATE HOLDER:**

HAGER CONSTRUCTION LLC  
5317 CHERRY LAWN DRIVE  
HUNTINGTON WV 25705

**INSURED:**

HAGER CONSTRUCTION LLC  
5317 CHERRY LAWN DRIVE  
HUNTINGTON WV 25705

**CERTIFICATE OF INSURANCE**

The policy of insurance listed below has been issued to the insured named above for the policy period and coverage indicated. This certificate is issued as a matter of information only and confers no rights upon the certificate holder. This certificate does not amend, extend or alter the coverage afforded by the policy below. Coverage is contingent on the insured's compliance with policy conditions and premium payment.

If the policy is canceled before the expiration date, BrickStreet Mutual Insurance Company will endeavor to mail a written notice to the certificate holder within 30 days of cancelation. Failure to mail the notice shall impose no obligation or liability of any kind upon BrickStreet Mutual Insurance Company.

**POLICY NUMBER: WC10034100-03**

**DATE CERTIFICATE ISSUED: 12/21/2006**

**POLICY EFFECTIVE DATE: 1/1/2007**

**POLICY EXPIRATION DATE: 12/12/2007**

**WORKERS COMPENSATION AND EMPLOYERS LIABILITY**

**LIMITS / COVERAGE**

**WORKERS COMPENSATION - STATUTORY LIMITS**

**EMPLOYERS LIABILITY LIMITS:**

<b>BODILY INJURY BY ACCIDENT:</b>	<b>\$100,000.00</b>	<b>EACH ACCIDENT</b>
<b>BODILY INJURY BY DISEASE:</b>	<b>\$500,000.00</b>	<b>POLICY LIMIT</b>
<b>BODILY INJURY BY DISEASE:</b>	<b>\$100,000.00</b>	<b>EACH EMPLOYEE</b>

**WV BROAD FORM EMPLOYERS LIABILITY ENDORSEMENT -  
COVERAGE FOR WV CODE 23-4-2(d)(2)(ii)**

**FEDERAL COAL MINE HEALTH AND SAFETY ACT COVERAGE ENDORSEMENT -  
COVERAGE FOR WV CODE 23-4b-1 - FEDERAL BLACK LUNG COVERAGE**

**SPECIAL PROVISIONS IF ANY:**

**RECEIVED DEC 29 2006**