



State of West Virginia  
 Department of Administration  
 Purchasing Division  
 2019 Washington Street East  
 Post Office Box 50130  
 Charleston, WV 25305-0130

# Request for Quotation

RFQ NUMBER  
**DEFK8003**

PAGE  
**1**

ADDRESS CORRESPONDENCE TO ATTENTION OF  
**JOHN ABBOTT**  
**304-558-2544**

RFQ COPY  
 TYPE NAME/ADDRESS HERE

*Walker Mach.*

DIV ENGINEERING & FACILITIES  
 NATIONAL GUARD ARMORY  
 240 ARMY ROAD  
 KINGWOOD, WV  
 26537  
 341-6368

DATE PRINTED <b>07/02/2007</b>	TERMS OF SALE	SHIP VIA	F.O.B.	FREIGHT TERMS
-----------------------------------	---------------	----------	--------	---------------

BID OPENING DATE: **07/18/2007** BID OPENING TIME **01:30PM**

LINE	QUANTITY	UOP	CAT. NO.	ITEM NUMBER	UNIT PRICE	AMOUNT
REQUEST FOR QUOTATION						
THE PURCHASING DIVISION IS SOLICITING BIDS FOR THE WEST VIRGINIA ARMY NATIONAL GUARD, CAMP DAWSON ARMY TRAINING SITE, KINGWOOD, WV, TO PROVIDE A SKID STEER LOADER, WITH 80" COMBINATION BUCKET & STEEL TRACK KIT.						
ATTACHMENTS: 1. SPECIFICATIONS 2. PURCHASING AFFIDAVIT						
0001	1	LS		760-51	Each	\$42,032.00
SKID STEER LOADER						
VENDOR PREFERENCE CERTIFICATE						
CERTIFICATION AND APPLICATION* IS HEREBY MADE FOR PREFERENCE IN ACCORDANCE WITH WEST VIRGINIA CODE, 5A-3-37 (DOES NOT APPLY TO CONSTRUCTION CONTRACTS).						
A. APPLICATION IS MADE FOR 2.5% PREFERENCE FOR THE REASON CHECKED:						
( ) BIDDER IS AN INDIVIDUAL RESIDENT VENDOR AND HAS RESIDED CONTINUOUSLY IN WEST VIRGINIA FOR FOUR (4) YEARS IMMEDIATELY PRECEDING THE DATE OF THIS CERTIFICATION; OR						
(✓) BIDDER IS A PARTNERSHIP, ASSOCIATION OR CORPORATION RESIDENT VENDOR AND HAS MAINTAINED ITS HEAD-QUARTERS OR PRINCIPAL PLACE OF BUSINESS CONTINUOUSLY IN WEST VIRGINIA FOR FOUR (4) YEARS IMMEDIATELY PRECEDING						

**RECEIVED**  
 2007 JUL 18 P 12:20  
 PURCHASING DIVISION  
 STATE OF WV

SEE REVERSE SIDE FOR TERMS AND CONDITIONS

SIGNATURE <i>[Signature]</i> Eric Ramey	TELEPHONE 304-389-4190	DATE 7/18/07
TITLE Sales Representative	FEIN 550 352 047	ADDRESS CHANGES TO BE NOTED ABOVE

WHEN RESPONDING TO RFQ, INSERT NAME AND ADDRESS IN SPACE ABOVE LABELED 'VENDOR'

**GENERAL TERMS & CONDITIONS  
REQUEST FOR QUOTATION (RFQ) AND REQUEST FOR PROPOSAL (RFP)**

1. Awards will be made in the best interest of the State of West Virginia.
2. The State may accept or reject in part, or in whole, any bid.
3. All quotations are governed by the *West Virginia Code* and the *Legislative Rules* of the Purchasing Division.
4. Prior to any award, the apparent successful vendor must be properly registered with the Purchasing Division and have paid the required \$125.00 registration fee.
5. All services performed or goods delivered under State Purchase Orders/Contracts are to be continued for the term of the Purchase Order/Contract, contingent upon funds being appropriated by the Legislature or otherwise being made available. In the event funds are not appropriated or otherwise available for these services or goods, this Purchase Order/Contract becomes void and of no effect after June 30.
6. Payment may only be made after the delivery and acceptance of goods or services.
7. Interest may be paid for late payment in accordance with the *West Virginia Code*.
8. Vendor preference will be granted upon written request in accordance with the *West Virginia Code*.
9. The State of West Virginia is exempt from federal and state taxes and will not pay or reimburse such taxes.
10. The Director of Purchasing may cancel any Purchase Order/Contract upon 30 days written notice to the seller.
11. The laws of the State of West Virginia and the *Legislative Rules* of the Purchasing Division shall govern all rights and duties under the Contract, including without limitation the validity of this Purchase Order/Contract.
12. Any reference to automatic renewal is hereby deleted. The Contract may be renewed only upon mutual written agreement of the parties.
13. **BANKRUPTCY:** In the event the vendor/contractor files for bankruptcy protection, this contract is automatically null and void, and is terminated without further order.
14. **HIPAA Business Associate Addendum** - The West Virginia State Government HIPAA Business Associate Addendum (BAA), approved by the Attorney General, and available online at the Purchasing Division's web site (<http://www.state.wv.us/admin/purchase/vrc/hipaa.htm>) is hereby made part of the agreement. Provided that, the Agency meets the definition of a Covered Entity (45 CFR §160.103) and will be disclosing Protected Health Information (45 CFR §160.103) to the vendor.

---

**INSTRUCTIONS TO BIDDERS**

1. Use the quotation forms provided by the Purchasing Division.
2. **SPECIFICATIONS:** Items offered must be in compliance with the specifications. Any deviation from the specifications must be clearly indicated by the bidder. Alternates offered by the bidder as **EQUAL** to the specifications must be clearly defined. A bidder offering an alternate should attach complete specifications and literature to the bid. The Purchasing Division may waive minor deviations to specifications.
3. Complete all sections of the quotation form.
4. Unit prices shall prevail in cases of discrepancy.
5. All quotations are considered F.O.B. destination unless alternate shipping terms are clearly identified in the quotation.
6. **BID SUBMISSION:** All quotations must be delivered by the bidder to the office listed below prior to the date and time of the bid opening. Failure of the bidder to deliver the quotations on time will result in bid disqualifications.

**SIGNED BID TO:**

Department of Administration  
Purchasing Division  
2019 Washington Street East  
Post Office Box 50130  
Charleston, WV 25305-0130



State of West Virginia  
 Department of Administration  
 Purchasing Division  
 2019 Washington Street East  
 Post Office Box 50130  
 Charleston, WV 25305-0130

# Request for Quotation

RFQ NUMBER:  
**DEFK8003**

PAGE:  
**2**

ADDRESS CORRESPONDENCE TO ATTENTION OF:  
**JOHN ABBOTT  
 304-558-2544**

VENDOR

RFQ COPY  
 TYPE NAME/ADDRESS HERE

SHIP TO

**DIV ENGINEERING & FACILITIES  
 NATIONAL GUARD ARMORY  
 240 ARMY ROAD  
 KINGWOOD, WV  
 26537 341-6368**

DATE PRINTED	TERMS OF SALE	SHIP VIA	F.O.B.	FREIGHT TERMS
07/02/2007				

BID OPENING DATE: **07/18/2007** BID OPENING TIME **01:30PM**

LINE	QUANTITY	UOP	CAT NO	ITEM NUMBER	UNIT PRICE	AMOUNT
<p>THE DATE OF THIS CERTIFICATION; OR 80% OF THE OWNERSHIP INTEREST OF BIDDER IS HELD BY ANOTHER INDIVIDUAL, PARTNERSHIP, ASSOCIATION OR CORPORATION RESIDENT VENDOR WHO HAS MAINTAINED ITS HEADQUARTERS OR PRINCIPAL PLACE OF BUSINESS CONTINUOUSLY IN WEST VIRGINIA FOR FOUR (4) YEARS IMMEDIATELY PRECEDING THE DATE OF THIS CERTIFICATION; OR</p> <p>( ) BIDDER IS A CORPORATION NONRESIDENT VENDOR WHICH HAS AN AFFILIATE OR SUBSIDIARY WHICH EMPLOYS A MINIMUM OF ONE HUNDRED STATE RESIDENTS AND WHICH HAS MAINTAINED ITS HEADQUARTERS OR PRINCIPAL PLACE OF BUSINESS WITHIN WEST VIRGINIA CONTINUOUSLY FOR THE FOUR (4) YEARS IMMEDIATELY PRECEDING THE DATE OF THIS CERTIFICATION.</p> <p>B. APPLICATION IS MADE FOR 2.5% PREFERENCE FOR THE REASON CHECKED:</p> <p>( ) BIDDER IS A RESIDENT VENDOR WHO CERTIFIES THAT, DURING THE LIFE OF THE CONTRACT, ON AVERAGE AT LEAST 75% OF THE EMPLOYEES WORKING ON THE PROJECT BEING BID ARE RESIDENTS OF WEST VIRGINIA WHO HAVE RESIDED IN THE STATE CONTINUOUSLY FOR THE TWO YEARS IMMEDIATELY PRECEDING SUBMISSION OF THIS BID;</p> <p>OR</p> <p>( ) BIDDER IS A NONRESIDENT VENDOR EMPLOYING A MINIMUM OF ONE HUNDRED STATE RESIDENTS OR IS A NONRESIDENT VENDOR WITH AN AFFILIATE OR SUBSIDIARY WHICH MAINTAINS ITS HEADQUARTERS OR PRINCIPAL PLACE OF BUSINESS WITHIN WEST VIRGINIA EMPLOYING A MINIMUM OF ONE HUNDRED STATE RESIDENTS WHO CERTIFIES THAT, DURING THE LIFE OF THE CONTRACT, ON AVERAGE AT LEAST 75% OF THE EMPLOYEES OR BIDDERS' AFFILIATE'S OR SUBSIDIARY'S EMPLOYEES ARE RESIDENTS OF WEST VIRGINIA WHO HAVE RESIDED IN THE STATE CONTINUOUSLY FOR THE TWO</p>						

SEE REVERSE SIDE FOR TERMS AND CONDITIONS						
SIGNATURE				TELEPHONE		DATE
TITLE		FEIN		ADDRESS CHANGES TO BE NOTED ABOVE		

WHEN RESPONDING TO RFQ, INSERT NAME AND ADDRESS IN SPACE ABOVE LABELED 'VENDOR'



State of West Virginia  
 Department of Administration  
 Purchasing Division  
 2019 Washington Street East  
 Post Office Box 50130  
 Charleston, WV 25305-0130

# Request for Quotation

RFQ NUMBER:  
**DEFK8003**

PAGE:  
**3**

ADDRESS CORRESPONDENCE TO ATTENTION OF:  
**JOHN ABBOTT  
 304-558-2544**

VENDOR

RFQ COPY  
 TYPE NAME/ADDRESS HERE

SHIP TO

**DIV ENGINEERING & FACILITIES  
 NATIONAL GUARD ARMORY  
 240 ARMY ROAD  
 KINGWOOD, WV  
 26537  
 341-6368**

DATE PRINTED	TERMS OF SALE	SHIP VIA	F.O.B.	FREIGHT TERMS
07/02/2007				

BID OPENING DATE: **07/18/2007** BID OPENING TIME **01:30PM**

LINE	QUANTITY	UOP	CAT NO	ITEM NUMBER	UNIT PRICE	AMOUNT
<p>YEARS IMMEDIATELY PRECEDING SUBMISSION OF THIS BID.</p> <p>BIDDER UNDERSTANDS IF THE SECRETARY OF TAX &amp; REVENUE DETERMINES THAT A BIDDER RECEIVING PREFERENCE HAS FAILED TO CONTINUE TO MEET THE REQUIREMENTS FOR SUCH PREFERENCE, THE SECRETARY MAY ORDER THE DIRECTOR OF PURCHASING TO: (A) RESCIND THE CONTRACT OR PURCHASE ORDER ISSUED; OR (B) ASSESS A PENALTY AGAINST SUCH BIDDER IN AN AMOUNT NOT TO EXCEED 5% OF THE BID AMOUNT AND THAT SUCH PENALTY WILL BE PAID TO THE CONTRACTING AGENCY OR DEDUCTED FROM ANY UNPAID BALANCE ON THE CONTRACT OR PURCHASE ORDER.</p> <p>BY SUBMISSION OF THIS CERTIFICATE, BIDDER AGREES TO DISCLOSE ANY REASONABLY REQUESTED INFORMATION TO THE PURCHASING DIVISION AND AUTHORIZES THE DEPARTMENT OF TAX AND REVENUE TO DISCLOSE TO THE DIRECTOR OF PURCHASING APPROPRIATE INFORMATION VERIFYING THAT BIDDER HAS PAID THE REQUIRED BUSINESS TAXES, PROVIDED THAT SUCH INFORMATION DOES NOT CONTAIN THE AMOUNTS OF TAXES PAID NOR ANY OTHER INFORMATION DEEMED BY THE TAX COMMISSIONER TO BE CONFIDENTIAL.</p> <p>UNDER PENALTY OF LAW FOR FALSE SWEARING (WEST VIRGINIA CODE 61-5-3), BIDDER HEREBY CERTIFIES THAT THIS CERTIFICATE IS TRUE AND ACCURATE IN ALL RESPECTS; AND THAT IF A CONTRACT IS ISSUED TO BIDDER AND IF ANYTHING CONTAINED WITHIN THIS CERTIFICATE CHANGES DURING THE TERM OF THE CONTRACT, BIDDER WILL NOTIFY THE PURCHASING DIVISION IN WRITING IMMEDIATELY.</p> <p>BIDDER: <u>CI Walker Machinery</u></p> <p>DATE: <u>7/18/07</u></p>						

SEE REVERSE SIDE FOR TERMS AND CONDITIONS

SIGNATURE <u>CEP</u>	TELEPHONE <u>304-389-4190</u>	DATE <u>7/18/07</u>
TITLE <u>Sales Representative</u>	FEIN <u>550-352-647</u>	ADDRESS CHANGES TO BE NOTED ABOVE

WHEN RESPONDING TO RFQ, INSERT NAME AND ADDRESS IN SPACE ABOVE LABELED 'VENDOR'



State of West Virginia  
 Department of Administration  
 Purchasing Division  
 2019 Washington Street East  
 Post Office Box 50130  
 Charleston, WV 25305-0130

# Request for Quotation

RFQ NUMBER  
**DEFK8003**

PAGE  
**4**

ADDRESS CORRESPONDENCE TO ATTENTION OF  
**JOHN ABBOTT**  
**304-558-2544**

VENDOR

RFQ COPY  
 TYPE NAME/ADDRESS HERE

SHIP TO

**DIV ENGINEERING & FACILITIES**  
**NATIONAL GUARD ARMORY**  
**240 ARMY ROAD**  
  
**KINGWOOD, WV**  
**26537**                      **341-6368**

DATE PRINTED	TERMS OF SALE	SHIP VIA	F.O.B.	FREIGHT TERMS
07/02/2007				

BID OPENING DATE: **07/18/2007**                      **BID OPENING TIME 01:30PM**

LINE	QUANTITY	UOP	CAT NO	ITEM NUMBER	UNIT PRICE	AMOUNT
<p>SIGNED: </p> <p>TITLE: <u>Sales Representative</u></p> <p>* CHECK ANY COMBINATION OF PREFERENCE CONSIDERATION(S) IN EITHER "A" OR "B", OR BOTH "A" AND "B" WHICH YOU ARE ENTITLED TO RECEIVE. YOU MAY REQUEST UP TO THE MAXIMUM 5% PREFERENCE FOR BOTH "A" AND "B". (REV. 12/00)</p> <p>NOTICE</p> <p>A SIGNED BID MUST BE SUBMITTED TO:</p> <p>DEPARTMENT OF ADMINISTRATION            PURCHASING DIVISION            BUILDING 15            2019 WASHINGTON STREET, EAST            CHARLESTON, WV 25305-0130</p> <p>THE BID SHOULD CONTAIN THIS INFORMATION ON THE FACE OF THE ENVELOPE OR THE BID MAY NOT BE CONSIDERED:</p> <p>SEALED BID</p> <p>BUYER:    JOHN ABBOTT-----</p> <p>RFQ. NO.:    DEFK8003-----</p> <p>BID OPENING DATE:                              7/18/2007-----</p>						

SEE REVERSE SIDE FOR TERMS AND CONDITIONS		
SIGNATURE	TELEPHONE	DATE
TITLE	FEIN	ADDRESS CHANGES TO BE NOTED ABOVE

WHEN RESPONDING TO RFQ, INSERT NAME AND ADDRESS IN SPACE ABOVE LABELED 'VENDOR'



State of West Virginia  
 Department of Administration  
 Purchasing Division  
 2019 Washington Street East  
 Post Office Box 50130  
 Charleston, WV 25305-0130

# Request for Quotation

RFQ NUMBER  
**DEFK8003**

PAGE  
**5**

ADDRESS CORRESPONDENCE TO ATTENTION OF  
**JOHN ABBOTT**  
**304-558-2544**

VENDOR

RFQ COPY  
 TYPE NAME/ADDRESS HERE

SUPPLIER

**DIV ENGINEERING & FACILITIES**  
**NATIONAL GUARD ARMORY**  
**240 ARMY ROAD**  
  
**KINGWOOD, WV**  
**26537**                      **341-6368**

DATE PRINTED	TERMS OF SALE	SHIP VIA	F.O.B.	FREIGHT TERMS
07/02/2007				

BID OPENING DATE: **07/18/2007**                      **BID OPENING TIME 01:30PM**

LINE	QUANTITY	UOP	CAT NO	ITEM NUMBER	UNIT PRICE	AMOUNT
BID OPENING TIME:				1:30 PM-----		
PLEASE PROVIDE A FAX NUMBER IN CASE IT IS NECESSARY TO CONTACT YOU REGARDING YOUR BID:						
				----- <b>304-759-6404</b> -----		
CONTACT PERSON (PLEASE PRINT CLEARLY):						
				----- <b>Eric Ramey</b> -----		
***** THIS IS THE END OF RFQ DEFK8003 *****						TOTAL: <b>\$42,032</b>

SEE REVERSE SIDE FOR TERMS AND CONDITIONS

SIGNATURE		TELEPHONE		DATE
TITLE	FEIN	ADDRESS CHANGES TO BE NOTED ABOVE		

WHEN RESPONDING TO RFQ, INSERT NAME AND ADDRESS IN SPACE ABOVE LABELED 'VENDOR'

STATE OF WEST VIRGINIA  
Purchasing Division

**PURCHASING AFFIDAVIT**

**West Virginia Code §5A-3-10a states:** No contract or renewal of any contract may be awarded by the state or any of its political subdivisions to any vendor or prospective vendor when the vendor or prospective vendor or a related party to the vendor or prospective vendor is a debtor and the debt owned is an amount greater than one thousand dollars in the aggregate

**DEFINITIONS:**

"Debt" means any assessment, premium, penalty, fine, tax or other amount of money owed to the state or any of its political subdivisions because of a judgment, fine, permit violation, license assessment, defaulted workers' compensation premium, penalty or other assessment presently delinquent or due and required to be paid to the state or any of its political subdivisions, including any interest or additional penalties accrued thereon.

"Debtor" means any individual, corporation, partnership, association, limited liability company or any other form or business association owing a debt to the state or any of its political subdivisions. "Political subdivision" means any county commission; municipality; county board of education; any instrumentality established by a county or municipality; any separate corporation or instrumentality established by one or more counties or municipalities, as permitted by law; or any public body charged by law with the performance of a government function or whose jurisdiction is coextensive with one or more counties or municipalities. "Related party" means a party, whether an individual, corporation, partnership, association, limited liability company or any other form or business association or other entity whatsoever, related to any vendor by blood, marriage, ownership or contract through which the party has a relationship of ownership or other interest with the vendor so that the party will actually or by effect receive or control a portion of the benefit, profit or other consideration from performance of a vendor contract with the party receiving an amount that meets or exceed five percent of the total contract amount.

**EXCEPTION:** The prohibition of this section does not apply where a vendor has contested any tax administered pursuant to chapter eleven of this code, workers' compensation premium, permit fee or environmental fee or assessment and the matter has not become final or where the vendor has entered into a payment plan or agreement and the vendor is not in default of any of the provisions of such plan or agreement.

**LICENSING:** Vendors must be licensed and in good standing in accordance with any and all state and local laws and requirements by any state or local agency of West Virginia, including, but not limited to, the West Virginia Secretary of State's Office, the West Virginia Tax Department, West Virginia Insurance Commission, or any other state agencies or political subdivision. Furthermore, the vendor must provide all necessary releases to obtain information to enable the Director or spending unit to verify that the vendor is licensed and in good standing with the above entities.

**CONFIDENTIALITY:** The vendor agrees that he or she will not disclose to anyone, directly or indirectly, any such personally identifiable information or other confidential information gained from the agency, unless the individual who is the subject of the information consents to the disclosure in writing or the disclosure is made pursuant to the agency's policies, procedures and rules. Vendors should visit [www.state.wv.us/admin/purchase/privacy](http://www.state.wv.us/admin/purchase/privacy) for the Notice of Agency Confidentiality Policies.

Under penalty of law for false swearing (West Virginia Code, §61-5-3), it is hereby certified that the vendor acknowledges the information in this said affidavit and are in compliance with the requirements as stated.

Vendor's Name: Eric Ramey

Authorized Signature:  Date: 7/18/07

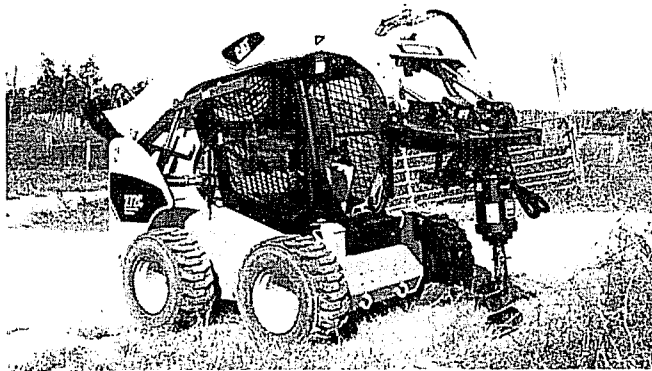

# Cat<sup>®</sup> 272C

## SKID STEER LOADER

### FEATURES:

The Cat<sup>®</sup> 272C Skid Steer Loader, with its long wheel base and vertical lift design, delivers extended reach and lift height for quick and easy truck loading. Its stability and lifting performance provides excellent material handling. The 272C features the following:

- **Sealed and pressurized cab option** provides a cleaner and quieter operating environment.
- **Seat mounted adjustable joystick controls and available air ride seat** make the C-Series the industry leader in operator comfort.
- **High performance power train** provides high engine horsepower and torque. Electronic Torque Management and standard foot throttle allow the machine to be operated at part throttle for lower sound levels and fuel consumption.
- **High Flow XPS hydraulic system** is available for applications that demand maximum hydraulic work tool performance.
- **Easy routine maintenance** helps reduce machine downtime for greater productivity.
- **Caterpillar's broad range of performance matched work tools** make the Cat Skid Steer Loader the most versatile machine on the jobsite.

## Specifications

### Engine

Engine Model	Cat <sup>®</sup> 3044C DIT	
Gross Power SAE J1995	70 kW	94 hp
Net Power SAE 1349	67 kW	90 hp
Displacement	3.3 L	201 in <sup>3</sup>
Stroke	120 mm	4.7 in
Bore	94 mm	3.7 in

### Weights

Operating Weight	3761 kg	8,292 lb
------------------	---------	----------

### Power Train

Travel Speed (Forward or Reverse):		
One Speed	11.6 kph	7.2 mph
Two Speed Option	16.1 kph	10.0 mph

### Hydraulic System

Hydraulic Flow – Standard:		
Loader Hydraulic Pressure	23 000 kPa	3,335 psi
Loader Hydraulic Flow	84 L/min	22 gal/min
Hydraulic Power	31.9 kW	42.8 hp
Hydraulic Flow – High Flow XPS:		
Max. Loader Hydraulic Pressure	28 000 kPa	4,061 psi
Max. Loader Hydraulic Flow	125 L/min	33 gal/min

### Operating Specifications

Rated Operating Capacity	1474 kg	3,250 lb
Rated Operating Capacity with Optional Counterweight	1579 kg	3,364 lb
Tipping Load	2948 kg	6,500 lb
Breakout Force, Tilt Cylinder	3318 kg	7,315 lb

### Cab

ROPS	SAE J1040 MAY94, ISO 3471:1994
FOPS	SAE J1043 SEPT87, ISO 3449:1992 Level I
FOPS Level II	SAE J231 JAN81, ISO 3449:1992 Level II

### Service Refill Capacities

Chain Box, each side	11 L	2.9 gal
Cooling System	14 L	3.7 gal
Engine Crankcase	10 L	2.6 gal
Fuel Tank	98 L	26 gal
Hydraulic System	57 L	15 gal
Hydraulic Tank	42 L	11 gal



# 272C Skid Steer Loader

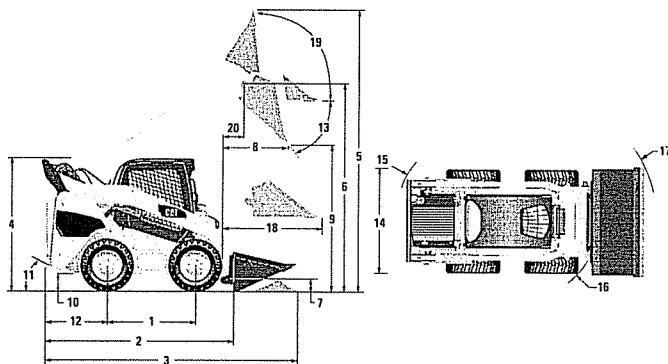

## Dimensions

1 Wheelbase	1381 mm	54 in
2 Length w/o Bucket	3265 mm	128.5 in
3 Length w/Bucket on Ground	3833 mm	150 in
4 Height to Top of Cab	2083 mm	82 in
5 Max. Overall Height	4115 mm	162 in
6 Bucket Pin Height at Max. Lift	3279 mm	129 in
7 Bucket Pin Height at Carry Position	200 mm	7.8 in
8 Reach at Max. Lift and Dump	764 mm	30 in
9 Clearance at Max. Lift and Dump	2487 mm	97.9 in
10 Ground Clearance	225 mm	8.8 in
11 Departure Angle	26°	
12 Bumper Overhang Behind Rear Axle	1089 mm	42.8 in
13 Maximum Dump Angle	51°	
14 Vehicle Width over Tires	1676 mm	66 in
15 Turning Radius from Center – Machine Rear	1481 mm	58.3 in
16 Turning Radius from Center – Coupler	1767 mm	69.6 in
17 Turning Radius from Center – Bucket	2577 mm	101.5 in
18 Max. Reach w/Arms Parallel to Ground	1270 mm	50 in
19 Rack Back Angle at Max. Height	83°	
20 Bucket Pin Reach at Max. Lift	373 mm	14.7 in

## MANDATORY EQUIPMENT

- Hydraulics, Standard or High Flow XPS
- Quick Coupler, Mechanical or Hydraulic
- Seat Belt, 50 mm (2 in) or 75 mm (3 in)

### COMFORT PACKAGE (must select one of the following)

- Open ROPS (C1): *Cup Holder, Radio Ready, Suspension Seat, (No Heater or Door)*
- Enclosed ROPS with Heat (C2): *Cup Holder, Radio Ready, Seat (choice of Suspension or Air Ride), Heater and Defroster, Side Windows, Door (either Glass or Polycarbonate)*
- Enclosed ROPS with A/C (C3): *C2 + Air Conditioner*

### PERFORMANCE PACKAGE (must select one of the following)

- Performance Package 1: *One Speed*
- Performance Package 2: *One Speed, Self Level*
- Performance Package 3: *Two Speed, Self Level*
- Performance Package 4: *Two Speed, Self Level, Ride Control, Advanced Machine Information and Control System (AMICS)*

## STANDARD EQUIPMENT

### ELECTRICAL

- 12 volt Electrical System
- 90 ampere Alternator
- Ignition Key Start/Stop Switch
- Lights: *Gauge Backlighting, Two Rear Tail Lights, Two Rear Working Lights, Two Adjustable Front Halogen Lights, Dome Light*
- Backup Alarm
- Heavy Duty Battery, 850 CCA

### OPERATOR ENVIRONMENT

- Gauges: *Fuel Level, Hour Meter*
- Operator Warning System Indicators: *Air Filter Restriction, Alternator Output, Armrest Raised/Operator Out of Seat, Engine Coolant Temperature, Engine Oil Pressure, Glow Plug Activation, Hydraulic Filter Restriction, Hydraulic Oil Temperature, Park Brake Engages*
- Vinyl Seat
- Fold in Ergonomic Contoured Armrest
- Control Interlock System, when operator leaves seat or armrest raised: *Hydraulic System Disables, Hydrostatic Transmission Disables, Parking Brake Engages*
- ROPS Cab, Open, Tilt Up
- FOPS, Level I
- Top and Rear Windows
- Headliner, Deluxe
- Floor Mat
- Interior Rear View Mirror
- 12 volt Electric Socket
- Horn

### POWER TRAIN

- Cat® 3044C DIT Tier 2 Compliant Diesel Engine
- Air Cleaner, Dual Element, Radial Seal
- S-O-S<sup>SM</sup> Sampling Valves, Engine Oil and Hydraulic Oil
- Filters, Spin-on, Hydraulic
- Filters, Bayonet-type, Fuel and Water Separator
- Tilt Up Radiator/Hydraulic Oil Cooler
- Spring Applied, Hydraulically Released, Wet Multi Disc Parking Brakes
- Hydrostatic Transmission
- Four Wheel Chain Drive

### OTHER

- Engine Enclosure, Lockable
- Extended Life Antifreeze, -37° C (-34° F)
- Machine Tie Down Points (4)
- Support, Lift Arm
- Hydraulic Oil Level Sight Gauge
- Radiator Coolant Level Sight Gauge
- Radiator, Expansion Bottle
- Caterpillar ToughGuard™ Hose
- Auxiliary, Hydraulics, Continuous Flow
- Heavy Duty, Flat Faced Quick Disconnects
- Split D-Ring to Route Work Tool Hoses Along Side of Left Lift Arm
- Electrical Outlet, Beacon
- Belly Pan Cleanout

## OPTIONAL ATTACHMENTS

- Counterweight, increases rated operating capacity 90 kg (200 lb)
- Beacon, Rotating
- Engine Block Heater – 120V or 240V
- Oil, Hydraulic, Cold Operation
- Paint, Custom

For more complete information on Cat products, dealer services, and industry solutions, visit us on the web at [www.cat.com](http://www.cat.com)

AEHQ5861 (1-07)

© 2007 Caterpillar  
All Rights Reserved  
Printed in U.S.A.

Materials and specifications are subject to change without notice. Featured machines in photos may include additional equipment. See your Caterpillar dealer for available options.

CAT, CATERPILLAR, their respective logos, "Caterpillar Yellow" and the POWER EDGE trade dress, as well as corporate and product identity used herein, are trademarks of Caterpillar and may not be used without permission.

**CATERPILLAR®**