



State of West Virginia
 Department of Administration
 Purchasing Division
 2019 Washington Street East
 Post Office Box 50130
 Charleston, WV 25305-0130

Request for Quotation

RFQ NUMBER
CME80496

PAGE
1

ADDRESS CORRESPONDENCE TO ATTENTION OF
ROBERTA WAGNER
304-558-0067

RFQ COPY
 TYPE NAME/ADDRESS HERE

AMIS, Inc
 221 22nd Street
 Huntington, WV 25703

HEALTH AND HUMAN RESOURCES
 BUREAU FOR PUBLIC HEALTH
 OFFICE CHIEF MEDICAL EXAMINER
 619 VIRGINIA STREET, WEST
 CHARLESTON, WV
 25302 304-558-4865

DATE PRINTED: 04/01/2008	TERMS OF SALE	SHIP VIA	FOB	FREIGHT TERMS
------------------------------------	---------------	----------	-----	---------------

BID OPENING DATE: **04/30/2008** BID OPENING TIME **01:30PM**

LINE	QUANTITY	UOP	CAT NO	ITEM NUMBER	UNIT PRICE	AMOUNT
0001	1	EA		898-74		\$98,237.84
AGFA/QUANTUM CR 30 DIGITAL IMAGING SYSTEM WITH SP PACKAGE OR EQUAL, PER THE ATTACHED SPECIFICATIONS. CANCELLATION: THE DIRECTOR OF PURCHASING RESERVES THE RIGHT TO CANCEL THIS CONTRACT IMMEDIATELY UPON WRITTEN NOTICE TO THE VENDOR IF THE COMMODITIES AND/OR SERVICES SUPPLIED ARE OF AN INFERIOR QUALITY OR DO NOT CONFORM TO THE SPECIFICATIONS OF THE BID AND CONTRACT HEREIN. BANKRUPTCY: IN THE EVENT THE VENDOR/CONTRACTOR FILES FOR BANKRUPTCY PROTECTION, THIS CONTRACT MAY BE DEEMED NULL AND VOID, AND TERMINATED WITHOUT FURTHER ORDER. INQUIRIES: WRITTEN QUESTIONS SHALL BE ACCEPTED THROUGH CLOSE OF BUSINESS ON 4/15/2008. QUESTIONS MAY BE SENT VIA USPS, FAX, COURIER OR E-MAIL. IN ORDER TO ASSURE NO VENDOR RECEIVES AN UNFAIR ADVANTAGE, NO SUBSTANTIVE QUESTIONS WILL BE ANSWERED ORALLY. IF POSSIBLE, E-MAIL QUESTIONS ARE PREFERRED. ADDRESS INQUIRIES TO: ROBERTA WAGNER DEPARTMENT OF ADMINISTRATION PURCHASING DIVISION 2019 WASHINGTON STREET, EAST CHARLESTON, WV 25311						

SEE REVERSE SIDE FOR TERMS AND CONDITIONS

SIGNATURE <i>Tom King</i>	TELEPHONE 1-304-525-8974	DATE 4-28-08
TITLE <i>VP of SALES</i>	FEIN 55-0525371	ADDRESS CHANGES TO BE NOTED ABOVE

WHEN RESPONDING TO RFQ, INSERT NAME AND ADDRESS IN SPACE ABOVE LABELED 'VENDOR'

**GENERAL TERMS & CONDITIONS
REQUEST FOR QUOTATION (RFQ) AND REQUEST FOR PROPOSAL (RFP)**

1. Awards will be made in the best interest of the State of West Virginia.
2. The State may accept or reject in part, or in whole, any bid.
3. All quotations are governed by the *West Virginia Code* and the *Legislative Rules* of the Purchasing Division.
4. Prior to any award, the apparent successful vendor must be properly registered with the Purchasing Division and have paid the required \$125.00 registration fee.
5. All services performed or goods delivered under State Purchase Orders/Contracts are to be continued for the term of the Purchase Order/Contract, contingent upon funds being appropriated by the Legislature or otherwise being made available. In the event funds are not appropriated or otherwise available for these services or goods, this Purchase Order/Contract becomes void and of no effect after June 30.
6. Payment may only be made after the delivery and acceptance of goods or services.
7. Interest may be paid for late payment in accordance with the *West Virginia Code*.
8. Vendor preference will be granted upon written request in accordance with the *West Virginia Code*.
9. The State of West Virginia is exempt from federal and state taxes and will not pay or reimburse such taxes.
10. The Director of Purchasing may cancel any Purchase Order/Contract upon 30 days written notice to the seller.
11. The laws of the State of West Virginia and the *Legislative Rules* of the Purchasing Division shall govern all rights and duties under the Contract, including without limitation the validity of this Purchase Order/Contract.
12. Any reference to automatic renewal is hereby deleted. The Contract may be renewed only upon mutual written agreement of the parties.
13. **BANKRUPTCY:** In the event the vendor/contractor files for bankruptcy protection, this Contract may be deemed null and void, and terminated without further order.
14. **HIPAA Business Associate Addendum -** The West Virginia State Government HIPAA Business Associate Addendum (BAA), approved by the Attorney General, and available online at the Purchasing Division's web site (<http://www.state.wv.us/admin/purchase/vrc/hipaa.htm>) is hereby made part of the agreement. Provided that, the Agency meets the definition of a Covered Entity (45 CFR §160.103) and will be disclosing Protected Health Information (45 CFR §160.103) to the vendor.

INSTRUCTIONS TO BIDDERS

1. Use the quotation forms provided by the Purchasing Division.
2. **SPECIFICATIONS:** Items offered must be in compliance with the specifications. Any deviation from the specifications must be clearly indicated by the bidder. Alternates offered by the bidder as **EQUAL** to the specifications must be clearly defined. A bidder offering an alternate should attach complete specifications and literature to the bid. The Purchasing Division may waive minor deviations to specifications.
3. Complete all sections of the quotation form.
4. Unit prices shall prevail in cases of discrepancy.
5. All quotations are considered F.O.B. destination unless alternate shipping terms are clearly identified in the quotation.
6. **BID SUBMISSION:** All quotations must be delivered by the bidder to the office listed below prior to the date and time of the bid opening. Failure of the bidder to deliver the quotations on time will result in bid disqualifications.

SIGNED BID TO:

Department of Administration
Purchasing Division
2019 Washington Street East
Post Office Box 50130
Charleston, WV 25305-0130



State of West Virginia
 Department of Administration
 Purchasing Division
 2019 Washington Street East
 Post Office Box 50130
 Charleston, WV 25305-0130

Request for Quotation

RFQ NUMBER
CME80496

PAGE
2

ADDRESS CORRESPONDENCE TO ATTENTION OF
**ROBERTA WAGNER
 304-558-0067**

RFQ COPY
 TYPE NAME/ADDRESS HERE

VENDOR

AMIS, Inc
 221 22nd Street
 Huntington, WV 25703

SHIP TO

HEALTH AND HUMAN RESOURCES
 BUREAU FOR PUBLIC HEALTH
 OFFICE CHIEF MEDICAL EXAMINER
 619 VIRGINIA STREET, WEST
 CHARLESTON, WV
 25302 304-558-4865

DATE PRINTED	TERMS OF SALE	SHIP VIA	FOB	FREIGHT TERMS
04/01/2008				

BID OPENING DATE: **04/30/2008** BID OPENING TIME **01:30PM**

LINE	QUANTITY	UOP	CAT NO	ITEM NUMBER	UNIT PRICE	AMOUNT
<p>FAX: 304-558-4115 E-MAIL: ROBERTA.A.WAGNER@WV.GOV</p> <p>THE MODEL/BRAND/SPECIFICATIONS NAMED HEREIN ESTABLISH THE ACCEPTABLE LEVEL OF QUALITY ONLY AND ARE NOT INTENDED TO REFLECT A PREFERENCE OR FAVOR ANY PARTICULAR BRAND OR VENDOR. VENDORS WHO ARE BIDDING ALTERNATES SHOULD SO STATE AND INCLUDE PERTINENT LITERATURE AND SPECIFICATIONS. FAILURE TO PROVIDE INFORMATION FOR ANY ALTERNATES MAY BE GROUNDS FOR REJECTION OF THE BID. THE STATE RESERVES THE RIGHT TO WAIVE MINOR IRREGULARITIES IN BIDS OR SPECIFICATION IN ACCORDANCE WITH SECTION 148-1-4(F) OF THE WEST VIRGINIA LEGISLATIVE RULES AND REGULATIONS.</p> <p>VENDOR PREFERENCE CERTIFICATE</p> <p>CERTIFICATION AND APPLICATION* IS HEREBY MADE FOR PREFERENCE IN ACCORDANCE WITH WEST VIRGINIA CODE, 5A-3-37 (DOES NOT APPLY TO CONSTRUCTION CONTRACTS).</p> <p>A. APPLICATION IS MADE FOR 2.5% PREFERENCE FOR THE REASON CHECKED:</p> <p>() BIDDER IS AN INDIVIDUAL RESIDENT VENDOR AND HAS RESIDED CONTINUOUSLY IN WEST VIRGINIA FOR FOUR (4) YEARS IMMEDIATELY PRECEDING THE DATE OF THIS CERTIFICATION; OR</p> <p>(X) BIDDER IS A PARTNERSHIP, ASSOCIATION OR CORPORATION RESIDENT VENDOR AND HAS MAINTAINED ITS HEAD-</p>						

SEE REVERSE SIDE FOR TERMS AND CONDITIONS

SIGNATURE <i>Tommy King</i>	TELEPHONE 1-304-525-8974	DATE 4-28-08
TITLE VP OF SALES	FEIN 55-0525371	ADDRESS CHANGES TO BE NOTED ABOVE

WHEN RESPONDING TO RFQ, INSERT NAME AND ADDRESS IN SPACE ABOVE LABELED 'VENDOR'



State of West Virginia
 Department of Administration
 Purchasing Division
 2019 Washington Street East
 Post Office Box 50130
 Charleston, WV 25305-0130

**Request for
 Quotation**

RFQ NUMBER
CME80496

PAGE
3

ADDRESS CORRESPONDENCE TO ATTENTION OF
**ROBERTA WAGNER
 304-558-0067**

RFQ COPY
 TYPE NAME/ADDRESS HERE

VENDOR

AMIS, Inc
 221 22nd Street
 Huntington, WV 25703

SHIP TO

HEALTH AND HUMAN RESOURCES
 BUREAU FOR PUBLIC HEALTH
 OFFICE CHIEF MEDICAL EXAMINER
 619 VIRGINIA STREET, WEST
 CHARLESTON, WV
 25302 304-558-4865

DATE PRINTED 04/01/2008	TERMS OF SALE	SHIP VIA	FOB	FREIGHT TERMS
-----------------------------------	---------------	----------	-----	---------------

BID OPENING DATE: **04/30/2008** BID OPENING TIME **01:30PM**

LINE	QUANTITY	UOP	CAT NO	ITEM NUMBER	UNIT PRICE	AMOUNT
<p>QUARTERS OR PRINCIPAL PLACE OF BUSINESS CONTINUOUSLY IN WEST VIRGINIA FOR FOUR (4) YEARS IMMEDIATELY PRECEDING THE DATE OF THIS CERTIFICATION; OR 80% OF THE OWNERSHIP INTEREST OF BIDDER IS HELD BY ANOTHER INDIVIDUAL, PARTNERSHIP, ASSOCIATION OR CORPORATION RESIDENT VENDOR WHO HAS MAINTAINED ITS HEADQUARTERS OR PRINCIPAL PLACE OF BUSINESS CONTINUOUSLY IN WEST VIRGINIA FOR FOUR (4) YEARS IMMEDIATELY PRECEDING THE DATE OF THIS CERTIFICATION; OR</p> <p>() BIDDER IS A CORPORATION NONRESIDENT VENDOR WHICH HAS AN AFFILIATE OR SUBSIDIARY WHICH EMPLOYS A MINIMUM OF ONE HUNDRED STATE RESIDENTS AND WHICH HAS MAINTAINED ITS HEADQUARTERS OR PRINCIPAL PLACE OF BUSINESS WITHIN WEST VIRGINIA CONTINUOUSLY FOR THE FOUR (4) YEARS IMMEDIATELY PRECEDING THE DATE OF THIS CERTIFICATION.</p> <p>B. APPLICATION IS MADE FOR 2.5% PREFERENCE FOR THE REASON CHECKED:</p> <p>(X) BIDDER IS A RESIDENT VENDOR WHO CERTIFIES THAT, DURING THE LIFE OF THE CONTRACT, ON AVERAGE AT LEAST 75% OF THE EMPLOYEES WORKING ON THE PROJECT BEING BID ARE RESIDENTS OF WEST VIRGINIA WHO HAVE RESIDED IN THE STATE CONTINUOUSLY FOR THE TWO YEARS IMMEDIATELY PRECEDING SUBMISSION OF THIS BID;</p> <p>OR</p> <p>() BIDDER IS A NONRESIDENT VENDOR EMPLOYING A MINIMUM OF ONE HUNDRED STATE RESIDENTS OR IS A NONRESIDENT VENDOR WITH AN AFFILIATE OR SUBSIDIARY WHICH MAINTAINS ITS HEADQUARTERS OR PRINCIPAL PLACE OF BUSINESS WITHIN WEST VIRGINIA EMPLOYING A MINIMUM OF ONE HUNDRED STATE RESIDENTS WHO CERTIFIES THAT, DURING THE LIFE OF THE CONTRACT, ON AVERAGE AT LEAST 75% OF THE EMPLOYEES OR BIDDERS' AFFILIATE'S OR</p>						

SEE REVERSE SIDE FOR TERMS AND CONDITIONS

SIGNATURE <i>Tom Sanders</i>	TELEPHONE 1-304-525-8974	DATE 4-28-08
TITLE <i>VP of SALES</i>	FEIN 55-0525371	ADDRESS CHANGES TO BE NOTED ABOVE

WHEN RESPONDING TO RFQ, INSERT NAME AND ADDRESS IN SPACE ABOVE LABELED 'VENDOR'



State of West Virginia
 Department of Administration
 Purchasing Division
 2019 Washington Street East
 Post Office Box 50130
 Charleston, WV 25305-0130

Request for Quotation

RFQ NUMBER
CME80496

PAGE
4

ADDRESS CORRESPONDENCE TO ATTENTION OF
**ROBERTA WAGNER
 304-558-0067**

RFQ COPY
 TYPE NAME/ADDRESS HERE

AMIS, Inc
 221 22nd Street
 Huntington, WV 25703

HEALTH AND HUMAN RESOURCES
 BUREAU FOR PUBLIC HEALTH
 OFFICE CHIEF MEDICAL EXAMINER
 619 VIRGINIA STREET, WEST
 CHARLESTON, WV
 25302 304-558-4865

DATE PRINTED 04/01/2008	TERMS OF SALE	SHIP VIA	FOB	FREIGHT TERMS
-----------------------------------	---------------	----------	-----	---------------

BID OPENING DATE: **04/30/2008** BID OPENING TIME **01:30PM**

LINE	QUANTITY	UQP	CAT NO	ITEM NUMBER	UNIT PRICE	AMOUNT
<p>SUBSIDIARY'S EMPLOYEES ARE RESIDENTS OF WEST VIRGINIA WHO HAVE RESIDED IN THE STATE CONTINUOUSLY FOR THE TWO YEARS IMMEDIATELY PRECEDING SUBMISSION OF THIS BID.</p> <p>BIDDER UNDERSTANDS IF THE SECRETARY OF TAX & REVENUE DETERMINES THAT A BIDDER RECEIVING PREFERENCE HAS FAILED TO CONTINUE TO MEET THE REQUIREMENTS FOR SUCH PREFERENCE, THE SECRETARY MAY ORDER THE DIRECTOR OF PURCHASING TO: (A) RESCIND THE CONTRACT OR PURCHASE ORDER ISSUED; OR (B) ASSESS A PENALTY AGAINST SUCH BIDDER IN AN AMOUNT NOT TO EXCEED 5% OF THE BID AMOUNT AND THAT SUCH PENALTY WILL BE PAID TO THE CONTRACTING AGENCY OR DEDUCTED FROM ANY UNPAID BALANCE ON THE CONTRACT OR PURCHASE ORDER.</p> <p>BY SUBMISSION OF THIS CERTIFICATE, BIDDER AGREES TO DISCLOSE ANY REASONABLY REQUESTED INFORMATION TO THE PURCHASING DIVISION AND AUTHORIZES THE DEPARTMENT OF TAX AND REVENUE TO DISCLOSE TO THE DIRECTOR OF PURCHASING APPROPRIATE INFORMATION VERIFYING THAT BIDDER HAS PAID THE REQUIRED BUSINESS TAXES, PROVIDED THAT SUCH INFORMATION DOES NOT CONTAIN THE AMOUNTS OF TAXES PAID NOR ANY OTHER INFORMATION DEEMED BY THE TAX COMMISSIONER TO BE CONFIDENTIAL.</p> <p>UNDER PENALTY OF LAW FOR FALSE SWEARING (WEST VIRGINIA CODE 61-5-3), BIDDER HEREBY CERTIFIES THAT THIS CERTIFICATE IS TRUE AND ACCURATE IN ALL RESPECTS; AND THAT IF A CONTRACT IS ISSUED TO BIDDER AND IF ANYTHING CONTAINED WITHIN THIS CERTIFICATE CHANGES DURING THE TERM OF THE CONTRACT, BIDDER WILL NOTIFY THE PURCHASING DIVISION IN WRITING IMMEDIATELY.</p> <p style="text-align: right;">AMIS, Inc.</p> <p>BIDDER: _____</p>						

SEE REVERSE SIDE FOR TERMS AND CONDITIONS

SIGNATURE <i>Tom Kails</i>	TELEPHONE 1-304-525-8974	DATE 4-28-08
TITLE <i>VP of SALES</i>	FEIN 55-0525371	ADDRESS CHANGES TO BE NOTED ABOVE

WHEN RESPONDING TO RFQ, INSERT NAME AND ADDRESS IN SPACE ABOVE LABELED 'VENDOR'



State of West Virginia
 Department of Administration
 Purchasing Division
 2019 Washington Street East
 Post Office Box 50130
 Charleston, WV 25305-0130

Request for Quotation

RFQ NUMBER
CME80496

PAGE
5

ADDRESS CORRESPONDENCE TO ATTENTION OF
ROBERTA WAGNER
304-558-0067

VENDOR

RFQ COPY
 TYPE NAME/ADDRESS HERE

AMIS, Inc
 221 22nd Street
 Huntington, WV 25703

SHIP TO

HEALTH AND HUMAN RESOURCES
 BUREAU FOR PUBLIC HEALTH
 OFFICE CHIEF MEDICAL EXAMINER
 619 VIRGINIA STREET, WEST
 CHARLESTON, WV
 25302 304-558-4865

DATE PRINTED	TERMS OF SALE	SHIP VIA	FOB	FREIGHT TERMS
04/01/2008				

BID OPENING DATE: **04/30/2008** BID OPENING TIME **01:30PM**

LINE	QUANTITY	UOP	CAT NO	ITEM NUMBER	UNIT PRICE	AMOUNT
<p>DATE: <u>4/28/08</u></p> <p>SIGNED: <u>Tom Kinler</u></p> <p>TITLE: <u>VP of SALES</u></p> <p>* CHECK ANY COMBINATION OF PREFERENCE CONSIDERATION(S) IN EITHER "A" OR "B", OR BOTH "A" AND "B" WHICH YOU ARE ENTITLED TO RECEIVE. YOU MAY REQUEST UP TO THE MAXIMUM 5% PREFERENCE FOR BOTH "A" AND "B". (REV. 12/00)</p> <p>NOTICE</p> <p>A SIGNED BID MUST BE SUBMITTED TO:</p> <p>DEPARTMENT OF ADMINISTRATION PURCHASING DIVISION BUILDING 15 2019 WASHINGTON STREET, EAST CHARLESTON, WV 25305-0130</p> <p>PLEASE NOTE: A CONVENIENCE COPY WOULD BE APPRECIATED.</p> <p>THE BID SHOULD CONTAIN THIS INFORMATION ON THE FACE OF THE ENVELOPE OR THE BID MAY NOT BE CONSIDERED:</p> <p>SEALED BID</p> <p>BUYER: -----RW/FILE 22-----</p> <p>RFQ. NO.: -----CME80496-----</p>						

SEE REVERSE SIDE FOR TERMS AND CONDITIONS

SIGNATURE <u>Tom Kinler</u>	TELEPHONE 1-304-525-8974	DATE 4-28-08
TITLE <u>VP of Sales</u>	FEIN 55-0525371	ADDRESS CHANGES TO BE NOTED ABOVE

WHEN RESPONDING TO RFQ, INSERT NAME AND ADDRESS IN SPACE ABOVE LABELED 'VENDOR'

**STATE OF WEST VIRGINIA
PURCHASE CONTINUATION SHEET**

Page ____ of ____ Pages		Requisition / P.O. No.: 8 CME80498
File: 22	Acct. No.: SEE PAGE 4	
Spending Unit: DHHR/OCME		

Vendor: _____ P.O. Date: _____

Item No.	Quantity	Description	Unit Price	Amount
		<p>SPECIFICATIONS CONTINUED:</p> <ul style="list-style-type: none"> o ID and Examination Software o DICOM Store/Send and DICOM Print features o "P-Value" Display Output For Compatible PACS o DICOM CD Export For DICOM CD Burning With a Viewer o 2 CR 35x43 Cassettes with CR Imaging Plates o 2 CR 24X30 Cassettes with CR Imaging Plates • Applications training for system and components quoted. • Basic Radiography training in the use of the system proposed in relation to the radiographic process provided by a qualified radiology education professional. <p>West Virginia Department of Health & Human Resources/Office of the Chief Medical Examiner staff will be trained by the selected vendor using a seminar format by presenting on the production of radiographic image as a digital image. The presentation will include exposure factors, the interaction of x-rays and matter, basic image receptor principles, image quality, basic patient positioning, radiation safety and basic physics of x-ray equipment. Consideration will be given to how processing and exposure variable affect the final digital image. Technique formulation and exposure compensation will be reviewed. The seminar will be customized. Session length may vary based on topics and will be specifically targeted to the operations of the WV State Medical Examiners Office personnel.</p> <p>Equipment will be delivered and installed no more than 60 days ARO. Training seminar must be completed prior to July 31, 2008.</p> <ul style="list-style-type: none"> • Installation and shipping costs will be included in proposal. • Minimum of 12 month warranty on all system components. <p>Note: Bids to be reviewed by Office Director prior to award.</p> <p>Abbreviations:</p> <p>CR = Computed Radiography MP = Megapixel which is a measurement of the resolution capability of a monitor / display DICOM = The Digital Imaging and Communications in Medicine (DICOM) standard for distributing and viewing any kind of medical image regardless of the origin. It is a universal standard for medical imaging. Equipment specified must meet this standard. PC = personal computer LCD = liquid crystal display DVD = Digital Versatile Disc" or "Digital Video Disc CD = Compact Disk RAID = Redundant Arrays of Inexpensive Disks Modality Worklist = Modality Worklist, enables primary imaging equipment (modalities) to query for Patient Demographics and Study Details from a information system where patient information is available. P-Value = a function capability that assures that a image will display (look) the same on other systems/devices as it does in the originating one.</p>		

AGREEMENT ADDENDUM

In the event of conflict between this addendum and the agreement, this addendum shall control:

1. **DISPUTES** - Any references in the agreement to arbitration or to the jurisdiction of any court are hereby deleted. Disputes arising out of the agreement shall be presented to the West Virginia Court of Claims.
2. **HOLD HARMLESS** - Any clause requiring the Agency to indemnify or hold harmless any party is hereby deleted in its entirety.
3. **GOVERNING LAW** - The agreement shall be governed by the laws of the State of West Virginia. This provision replaces any references to any other State's governing law.
4. **TAXES** - Provisions in the agreement requiring the Agency to pay taxes are deleted. As a State entity, the Agency is exempt from Federal, State, and local taxes and will not pay taxes for any Vendor including individuals, nor will the Agency file any tax returns or reports on behalf of Vendor or any other party.
5. **PAYMENT** - Any references to prepayment are deleted. Payment will be in arrears.
6. **INTEREST** - Should the agreement include a provision for interest on late payments, the Agency agrees to pay the maximum legal rate under West Virginia law. All other references to interest or late charges are deleted.
7. **RECOUPMENT** - Any language in the agreement waiving the Agency's right to set-off, counterclaim, recoupment, or other defense is hereby deleted.
8. **FISCAL YEAR FUNDING** - Service performed under the agreement may be continued in succeeding fiscal years for the term of the agreement, contingent upon funds being appropriated by the Legislature or otherwise being available for this service. In the event funds are not appropriated or otherwise available for this service, the agreement shall terminate without penalty on June 30. After that date, the agreement becomes of no effect and is null and void. However, the Agency agrees to use its best efforts to have the amounts contemplated under the agreement included in its budget. Non-appropriation or non-funding shall not be considered an event of default.
9. **STATUTE OF LIMITATION** - Any clauses limiting the time in which the Agency may bring suit against the Vendor, lessor, individual, or any other party are deleted.
10. **SIMILAR SERVICES** - Any provisions limiting the Agency's right to obtain similar services or equipment in the event of default or non-funding during the term of the agreement are hereby deleted.
11. **ATTORNEY FEES** - The Agency recognizes an obligation to pay attorney's fees or costs only when assessed by a court of competent jurisdiction. Any other provision is invalid and considered null and void.
12. **ASSIGNMENT** - Notwithstanding any clause to the contrary, the Agency reserves the right to assign the agreement to another State of West Virginia agency, board or commission upon thirty (30) days written notice to the Vendor and Vendor shall obtain the written consent of Agency prior to assigning the agreement.
13. **LIMITATION OF LIABILITY** - The Agency, as a State entity, cannot agree to assume the potential liability of a Vendor. Accordingly, any provision limiting the Vendor's liability for direct damages to a certain dollar amount or to the amount of the agreement is hereby deleted. Limitations on special, incidental or consequential damages are acceptable. In addition, any limitation is null and void to the extent that it precludes any action for injury to persons or for damages to personal property.
14. **RIGHT TO TERMINATE** - Agency shall have the right to terminate the agreement upon thirty (30) days written notice to Vendor. Agency agrees to pay Vendor for services rendered or goods received prior to the effective date of termination.
15. **TERMINATION CHARGES** - Any provision requiring the Agency to pay a fixed amount or liquidated damages upon termination of the agreement is hereby deleted. The Agency may only agree to reimburse a Vendor for actual costs incurred or losses sustained during the current fiscal year due to wrongful termination by the Agency prior to the end of any current agreement term.
16. **RENEWAL** - Any reference to automatic renewal is hereby deleted. The agreement may be renewed only upon mutual written agreement of the parties.
17. **INSURANCE** - Any provision requiring the Agency to insure equipment or property of any kind and name the Vendor as beneficiary or as an additional insured is hereby deleted.
18. **RIGHT TO NOTICE** - Any provision for repossession of equipment without notice is hereby deleted. However, the Agency does recognize a right of repossession with notice.
19. **ACCELERATION** - Any reference to acceleration of payments in the event of default or non-funding is hereby deleted.
20. **CONFIDENTIALITY** - Any provision regarding confidentiality of the terms and conditions of the agreement is hereby deleted. State contracts are public records under the West Virginia Freedom of Information Act.
21. **AMENDMENTS** - All amendments, modifications, alterations or changes to the agreement shall be in writing and signed by both parties. No amendment, modification, alteration or change may be made to this addendum without the express written approval of the Purchasing Division and the Attorney General.

ACCEPTED BY:

STATE OF WEST VIRGINIA

Spending Unit: _____

Signed: _____

Title: _____

Date: _____

VENDOR

Company Name: AMIS SYSTEMS

Signed: Tom Kivil

Title: VP OF SALES

Date: 4/28/08

ATTACHMENT
P.O.# RFQ CME80496

This agreement constitutes the entire agreement between the parties, and there are no other terms and conditions applicable to the licenses granted hereunder.

Agreed

Tom Kral 4/28/09
Signature Date

VP SALES
Title

AMIS
Company Name

Signature Date

Title

Agency/Division

STATE OF WEST VIRGINIA
Purchasing Division

PURCHASING AFFIDAVIT

West Virginia Code §5A-3-10a states: No contract or renewal of any contract may be awarded by the state or any of its political subdivisions to any vendor or prospective vendor when the vendor or prospective vendor or related party to the vendor or prospective vendor is a debtor and the debt owed is an amount greater than one thousand dollars in the aggregate

DEFINITIONS:

Debt means any assessment, premium, penalty, fine, tax or other amount of money owed to the state or any of its political subdivisions because of a judgment, fine, permit violation, license assessment, defaulted workers' compensation premium, penalty or other assessment presently delinquent or due and required to be paid to the state or any of its political subdivisions, including any interest or additional penalties accrued thereon

Debtor means any individual, corporation, partnership, association, limited liability company or any other form of business association owing a debt to the state or any of its political subdivisions. "Political subdivision" means any county commission; municipality; county board of education; any instrumentality established by a county or municipality; any separate corporation or instrumentality established by one or more counties or municipalities, as permitted by law; or any public body charged by law with the performance of a government function or whose jurisdiction is coextensive with one or more counties or municipalities. "Related party" means a party, whether an individual, corporation, partnership, association, limited liability company or any other form of business association or other entity whatsoever, related to any vendor by blood, marriage, ownership or contract through which the party has a relationship of ownership or other interest with the vendor so that the party will actually or by effect receive or control a portion of the benefit, profit or other consideration from performance of a vendor contract with the party receiving an amount that meets or exceeds five percent of the total contract amount.

EXCEPTION: The prohibition of this section does not apply where a vendor has contested any tax administered pursuant to chapter eleven of this code, workers' compensation premium, permit fee or environmental fee or assessment and the matter has not become final or where the vendor has entered into a payment plan or agreement and the vendor is not in default of any of the provisions of such plan or agreement.

LICENSING: Vendors must be licensed and in good standing in accordance with any and all state and local laws and requirements by any state or local agency of West Virginia, including, but not limited to, the West Virginia Secretary of State's Office, the West Virginia Tax Department, West Virginia Insurance Commission, or any other state agencies or political subdivision. Furthermore, the vendor must provide all necessary releases to obtain information to enable the Director or spending unit to verify that the vendor is licensed and in good standing with the above entities.

CONFIDENTIALITY: The vendor agrees that he or she will not disclose to anyone, directly or indirectly, any such personally identifiable information or other confidential information gained from the agency, unless the individual who is the subject of the information consents to the disclosure in writing or the disclosure is made pursuant to the agency's policies, procedures and rules. Vendors should visit www.state.wv.us/admin/purchase/privacy for the Notice of Agency Confidentiality Policies.

Under penalty of law for false swearing (West Virginia Code, §61-5-3), it is hereby certified that the vendor acknowledges the information in this said affidavit and are in compliance with the requirements as stated.

Vendor's Name: AMIS SYSTEMS

Authorized Signature: Tom Kunkle Date: 4/28/08

**** ANNUAL STUDY VOLUME & AVERAGE STUDY SIZE **** System performance, processing speed, storage capacity, study retrieval time and more are effected by volume of data processed. In order to provide the most appropriate solution, it is important to understand data volume correctly. This quotation and its components have been configured based upon the assumption that Study Volume is equal to, or less than, the eRAD PACS Viewer license provision granted to the Enterprise and that for this Enterprise, the AVERAGE STUDY SIZE is 32 MB and the ANNUAL STUDY VOLUME is 5,000.

**** SOFTWARE ****

**** eRAD PACS CORE SOFTWARE DEFINITION **** Includes SMARTSERVER, VIEWER and WORKFLOW software applications that provide unlimited concurrent-user and referring-physician access to patient studies and reports governed by the annual study volume of the eRAD SMARTSERVER, VIEWER & WORKFLOW Software License quoted (and required) in this configuration and subject to the Terms & Conditions attached. eRAD PACS SMARTSERVER, VIEWER & WORKFLOW applications are fully scalable. The eRAD PACS Viewer is a full-featured, diagnostic-quality toolset for displaying current and prior images and reports. It is downloadable, self-installing, web-native and runs under Windows. SMARTSERVER software features flexible routing and customizable worklist, hanging protocols, viewer controls and facilitates secure access to studies and reports from -anywhere- with Internet access. WORKFLOW software includes auto-notification and remote access for radiologists as well as referring physicians, dictation recording & playback, annotated reports, electronic signature, collaboration capability, web-accessible transcriptionist access, simple end-user administrative controls and customized Linux o/s. Supports up to four diagnostic monitors and one worklist-display monitor. eRAD PACS is HIPAA compliant with full-audit trails, inactivity log-outs and other security measures. SMARTSERVER is remotely serviceable and provides secure up-time. In the event annual study volume exceeds the licensed level originally purchased, customer must upgrade the license to the appropriate volume level.

**** eRAD PACS SMARTSERVER, VIEWER & WORKFLOW MANAGMENT **** Software Licensed according to the Description provided in the item ANNUAL STUDY VOLUME & AVERAGE STUDY SIZE. Includes productivity-enhancing, customizable, web-based administrative tools for worklist management and quality control. Provides event-driven workflow automation, auto-distribution of reports, unique pre-fetch and auto-redirection network-communication protocols. eRAD's customized SMARTSERVER Linux O/S assures secure up-time and is remotely serviceable. Unlimited User and Referring Physician licenses and unlimited (pre-certified) DICOM Modality connections at time of installation.

**** SERVER ARCHIVE **** Software License for sites with annual volumes of up to 10,000 studies enables an initial SmartServer configuration to manage hard disk space for studies & reports resident on the RAID-5 formatted storage array (1:1) of the SmartServer (minimum recommended HDD size 4x300GB)

**** DICOM PRINTING **** Software Site License enables DICOM Printing (batch or single-study) to existing DICOM-Ready Printers from workstations.

**** eRAD PACS CD/DVD CREATION **** Software SITE LICENSE may be used with existing workstation-mounted CD/DVD Burners to enable placement of selected DICOM Patient Studies onto discs. The eRAD PACS Viewer may be included on the CD/DVD by the operator for Plug-n-Play Viewing by Referring MDs, Diagnosticians, Clinicians and Patients.

**** HARDWARE ****

**** SMARTSERVER TOWER or RACK **** Dell Server, Tower or Rack-mounted (RAID 5 = 5x300GB SCSI 15K RPM drives). Often used as the Enterprise HUB

Server. Includes UPS, O/S Lic.,

**** eRAD PACS RADIOLOGIST'S 2MPx1 VALUE-PRICED DIAGNOSTIC WORKSTATION **** 2MP SINGLE portrait grayscale flat-panel, 19.6" NATIONAL DISPLAY AXIS Hi-Brite monitor (1600x1200 res.), w/stands and Dual-Head Video Display Card, 1-Yr. Warranty. w/ Color 19" worklist reference monitor w/stand, video card and Dell Optiplex 745 Windows Wkstn (tower) w/ CD/DVD Read/Write drive,

**** APPLICATIONS TRAINING & SERVICES ****

**** WEB-EX TRAINING SESSIONS **** APPLICATIONS TRAINING is provided by eRAD IN COOPERATION WITH THE CUSTOMER. eRAD will provide ONE (1) Remote Training Session to Customer personnel consisting of up to two (2) contiguous hours. Appointment scheduled at mutually agreed-upon time.

**** APPLICATIONS & PACS ADMINISTRATOR TRAINING by eRAD **** eRAD provides On-Site, contiguous, eight (8)-hour days dedicated to training of Customer personnel on use of eRAD PACS VIEWER and Administration of SMARTSERVER and WORKFLOW applications. Session is to be scheduled prior to the event by mutual agreement of the parties to occur on a day adjacent to on-site eRAD PACS APPLICATIONS Training.

**** IMPLEMENTATION ****

**** IMPLEMENTATION STAGING by eRAD **** Staging by eRAD includes Worklist Population, Rights Assignments, Workflow Configuration and Pre-certification of Modality Devices.

**** ON-SITE INSTALLATION** install hardware and software as according to a mutually agreed upon schedule.



eRAD PACS CLASSIC EDITION is a flexible, web-based image workflow solution, designed for distributed clinical environments made up of remote imaging facilities, associated through ownership, reading service group or location. The Classic Edition provides complete PACS functionality, including acquisition, archival, and disaster recovery. Options are provided a-la-carte, allowing the system to evolve as your needs mature.

eRAD PACS Classic Edition offers:

- Reliable worklist consolidation and event driven workflow across distributed facilities
- Customizable configuration, integrating multiple modalities, RIS, EMR and other systems
- Conditional archiving options across multiple storage facilities
- Several data backup solutions available
- Best economical solution with a-la-carte options

Distributed Imaging Environment – eRAD PACS Classic Edition supplies users with consolidated worklists across multiple imaging facilities. Users access data from one or more of these connected facilities based on their assigned access privileges or physical location. Changes made to the data at one facility promptly propagate throughout the eRAD PACS system, keeping the data consistent and accurate for all users.

Download Redirection – Imaging centers connected across a slow or even moderate wide area network still gets the benefit of fast download times to user workstations. eRAD PACS Classic Edition's Redirection feature automatically determines the fastest retrieval path for any study. The web-based architectural structure is designed for maximum efficiency and flexibility across all network topologies and data rates.

Site-Dependent Archiving – eRAD PACS Classic Edition supports independent archives in each of the imaging facilities. Keep your data from being commingled with another site's data, yet give radiologists and other users the benefit of seeing all the data from a single worklist. Access to the data in each archive is protected by privileges managed by the system administrator.

Event Driven Workflow – When multiple facilities come together as a single operating entity, the need for seamless communications is paramount. eRAD PACS Classic Edition has the event driven workflow tools to ensure consistent quality of services. Using eRAD PACS Event Actions, users set up custom events to notify themselves and others when a process needs their attention. eRAD PACS drives the workflow to completion-from studies waiting to be interpreted, to dictations needing transcription, to referring physicians downloading the approved report.

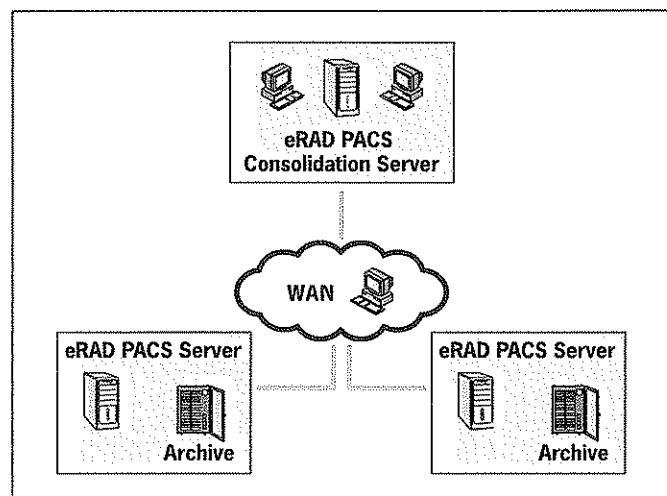
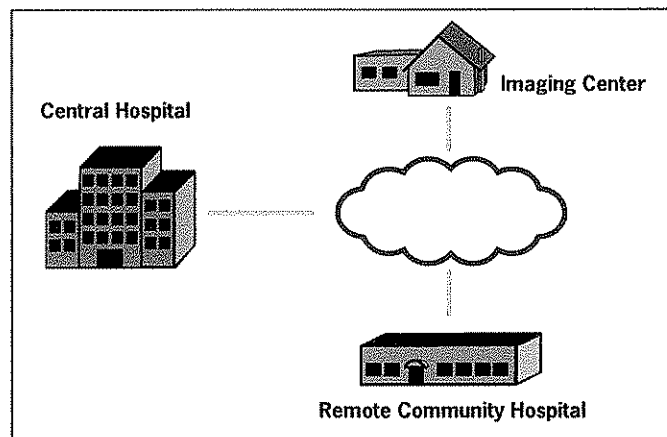



Systems Implementation – eRAD PACS has fine tuned the process of implementing PACS in the most demanding environments. Our flexible approach to HL7 provides bi-directional HL7 communication to HIS, RIS, EMR, CPR/CPOE, and practice management systems. The eRAD PACS easily-configurable DICOM interface can provide DICOM Modality Worklist, and simple DICOM storage capabilities for a variety of modalities. An available HTTP interface is also available for simple integration third-party systems, providing access to all images, reports, and other data stored in eRAD PACS.

Expandability – eRAD PACS Classic Edition allows you to start with what you need right now, and add capacity, incorporate new facilities, and upgrade aging equipment as your business matures. Expanding on an as-needed basis helps keep investment costs to a minimum.

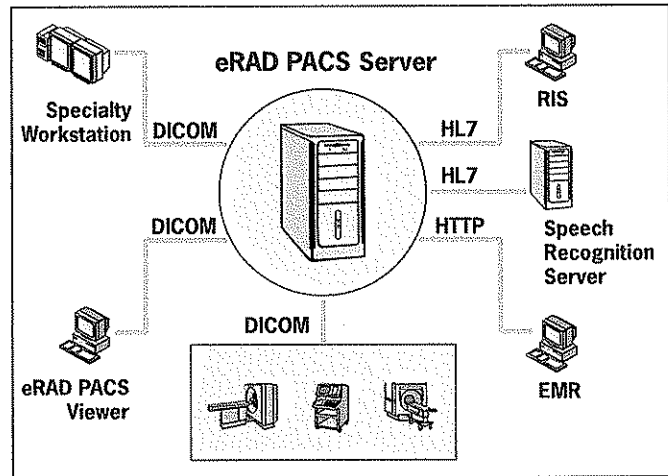

“With five imaging centers, our objective was to centralize our reading and archiving activities to improve turn-around time and reduce storage costs. eRAD PACS has done this for us, without restricting user mobility. Radiologists log in from any of our centers and get a view of all five on a single screen. They are more productive and our referring physicians are better served.”

Michael Remkus – Chief Technology Officer, Midtown Imaging, LLC

Diagnostic Viewer – eRAD PACS Classic Edition uses the eRAD PACS Viewer, providing full-fidelity image rendering capabilities, advanced imaging tools including MPR, 3D and synchronized cine mode, and tools for diagnostic interpretation, report dictation, transcription, and speech recognition. Multiple users collaborate through a bi-directional session in which they interactively view and manipulate the same data. After annotating, sizing and positioning clinically significant images, their presentation state can be preserved by attaching them to the report as key images. The eRAD PACS viewer provides a common interface and tool set regardless of where it is used, including radiology workstations, remote clinical workstations, web-based workstations, and CDs distributed to referring physicians.

Ask the eRAD team of professionals to assess your needs and tell you more about the features and benefits of the eRAD PACS Classic Edition.

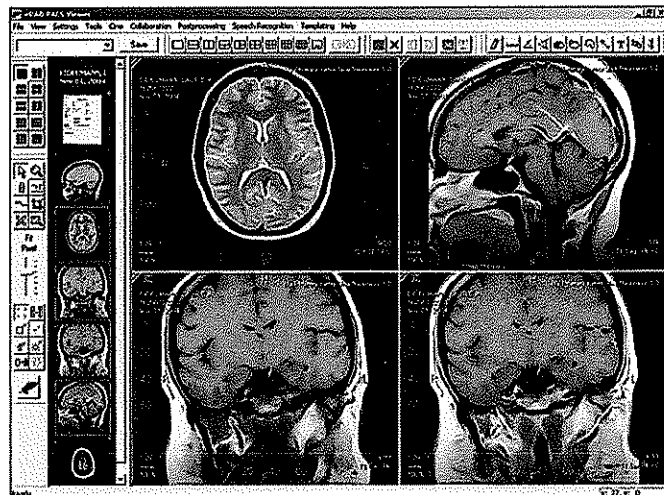

For more information or to receive a free demonstration of eRAD PACS, go to www.eradpacs.com or call (864) 234-7430

CR 30-X

Digitizer

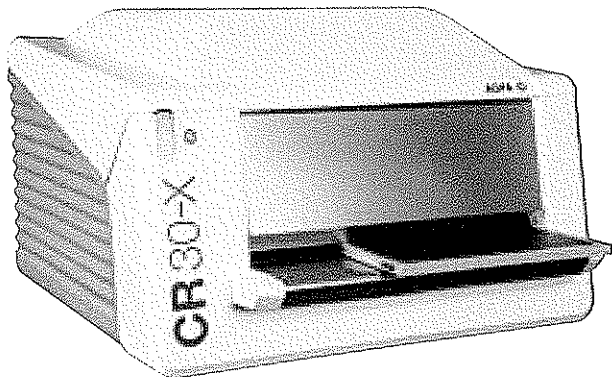

- TABLE-TOP DIGITIZER
- BROAD RANGE OF APPLICATIONS
- LOW COST OF OWNERSHIP
- HORIZONTAL CASSETTE INSERTION
- MOBILE

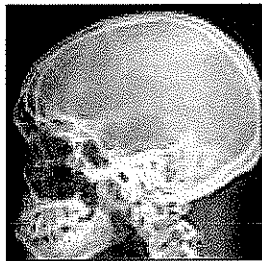
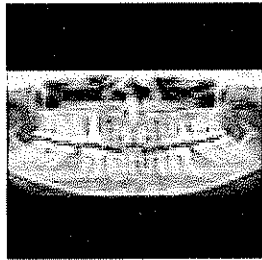
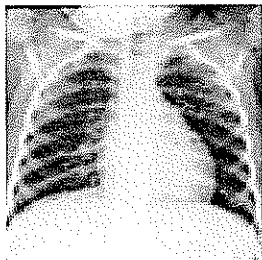

NO QUALITY COMPROMISES

Broad range of applications

CR 30-X is a highly versatile digitizer. It offers an ideal solution for any private and decentralized CR environment. CR 30-X can handle general radiology and dental applications.

Full data

The CR 30-X makes no compromises in image quality: it reads imaging plates at the high resolution of 10 pixels/mm for all image plate sizes.

Table-top

With its table-top size, the CR 30-X digitizer can be placed easily at any location. It works with dedicated cassettes and was designed with ease of use in mind, for optimal handling, comfort and maintenance. When combined with the optionally available universal X-ray shielding, the CR 30-X can be used inside the X-ray room.

Low total cost of ownership

Installing the CR 30-X can be done in a single day. With the special LED technology in the erasure unit, no additional electricity is required, so standard electrical outlets are sufficient. No preliminary electrical work means a lower set-up cost and simpler installation. With its modular, component-based design, it offers faster, easier and more cost-effective maintenance.

NX

CR 30-X is available in combination with NX, Agfa's image identification and quality control tool, for a highly efficient and optimized radiology workflow.

Cassettes with memory

CR 30-X uses dedicated cassettes with an embedded memory that stores the data entered during identification. The built-in antenna card identifies the data by no-touch radiofrequency tagging. ID data and images are linked from the beginning throughout the entire electronic processing system.

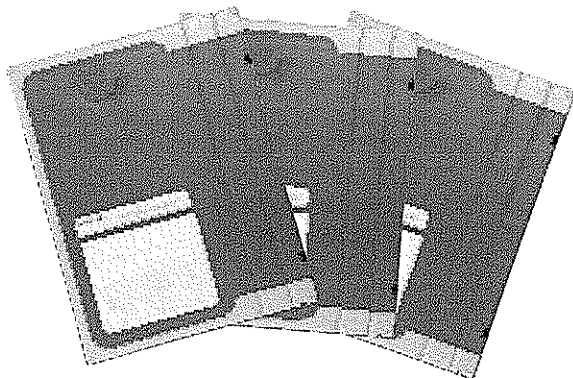

CASSETTE SIZES: CR MD4.0T GENERAL CASSETTES

Accepted Cassette Sizes	Spatial Resolution	Pixel Matrix Size
Resolution		
35 x 43 cm (14 x 17")	10 pixels / mm	3480 x 4248
24 x 30 cm	10 pixels / mm	2328 x 2928
18 x 24 cm	10 pixels / mm	1728 x 2328
15 x 30 cm	10 pixels / mm	1440 x 2928

technical

SPECIFICATIONS

GENERAL

Digitizer type

- Single cassette feed
- Throughput:
 - 35 x 43 cm (14 x 17") = approx. 60 plates/hour
 - 24 x 30 cm (9.5 x 12") = approx. 71 plates/hour
 - 18 x 24 cm (7 x 9.5") = approx. 76 plates/hour
 - 15 x 30 cm (6 x 12") = approx. 82 plates/hour

Display

- LED Status Indicator
- Status and error messages on external PC monitor

Greyscale resolution

- Data acquisition: 20 bits/pixel
- Output to processor: 16 bits/pixel

Dimensions and weight

- (W x D x H): 693 x 701 x 464 mm (27.2 x 27.6 x 18.2")
 - Depth including input tray: 769 mm (30.3")
- Weight: approx. 98 kg (216.05 lbs)

Power

- 220 - 240 V/50-60 Hz
 - Standby 120W, max 320W, 16A fuse
- 120V/60Hz (USA)
 - Standby 120W, max 320W, 15A fuse
- 100V/60Hz (Japan)
 - Standby 120W, max 320W, 15A fuse

Minimum requirements

- CR MD 4.0T General Cassette
- CR MD 4.0 General Plate
- NX

Environmental conditions

- Temperature: 15 - 30 °C (59 - 86°F)
- Humidity: 15 - 80% RH
- Magnetic fields: max. 3.8 μ T in conformance with EN 61000-4-8: level 2
- Rate of change of temperature: 0.5°C/minute (0.9°F)

Environmental effects

- Noise level: max. 65 dB (A)
- Heat dissipation: standby 120 W, max. 320 W

SAFETY

Approvals

- UL, cUL, CE

Transport details

- Temperature: -25 to +55°C (-4 to 131°F),
 - 25°C for max. 72 hours, +55°C for max. 96 hours
- Humidity: 5 - 95% RH

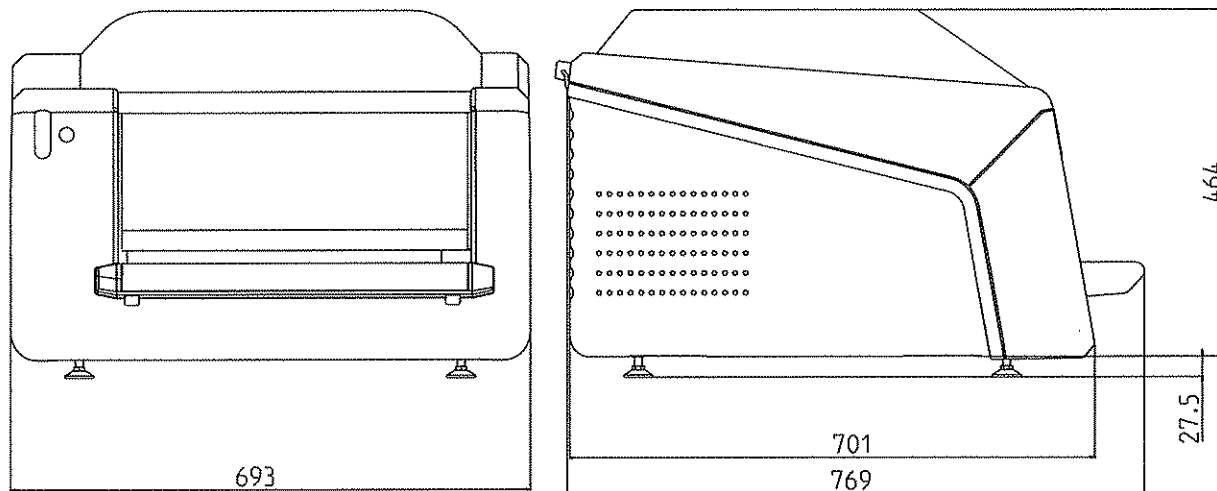

SAFETY

Region	Regulation	X-Ray	Laser
Europe	EN 60601-1: 1990 + A1: 1993 + A2: 1995 EN 60601-1-2: 2001	Regulation: 1987	EN 60825 - 1:2001
USA	UL 60601-1 21CFR part 820: good manufacturing practice for medical devices	DHHS/FDA 21 CFR part 1002, subchapter B	DHHS/FDA 21 CFR parts 1040, 10 and 1040, 11
Canada	CSA22.2 No.601.1 No.601.1.2		

 Agfa-Gevaert has been certified by Lloyd's Register Quality Assurance Limited to the following quality management system standard: ISO 9001:2000. The quality management system is applicable to: For Healthcare applications - Marketing, design, development and production of imaging and communication solutions (film, paper and plates, chemicals, components, equipment and software).

 Agfa-Gevaert has been awarded the Approval of Conformity certificate by Lloyd's Register Quality Assurance. It certifies that the Quality Management System for our X-Ray films conforms to the requirements of Annex V of the EEC Directive 93/42. Agfa HealthCare has been certified by Lloyd's Register Quality Assurance Limited to the following quality management system standards: ISO 9001:2000 and EN ISO 13485-2003. The quality management system is applicable to: marketing, design, development and production of imaging and communication solutions (film, paper and plates, chemicals, components, equipment and software) for Healthcare applications. Agfa-Gevaert had been awarded the ISO 9001 certificate by TÜV Zertifizierungsgemeinschaft e.V. This is applicable to Agfa's Quality Management System for design, production and servicing of Agfa Medical Equipment. Products distributed in North America are manufactured by/for Agfa Corporation, 10 South Academy St., Greenville, South Carolina 29601. Agfa and the Agfa rhombus are trademarks of Agfa-Gevaert N.V., Belgium or its affiliates. All other trademarks are held by their respective owners and are used in an editorial fashion with no intention of infringement. The data in this publication are for illustration purposes only and do not necessarily represent standards or specifications which must be met by Agfa. All information contained herein is intended for guidance purposes only, and characteristics of the products described in this publication can be changed at any time without notice. Products may not be available for your local area. Please contact your local sales representative for availability information. Agfa diligently strives to provide as accurate information as possible, but shall not be responsible for any typographical error.

Agfa Corporation
HealthCare Headquarters
10 South Academy Street,
Greenville, SC 29601

Canada
Agfa, Inc.
77 Belfield Road, Etobicoke, Ont.,
M9W 1G6

Mexico
Agfa de México, S.A. de C.V.
Benjamin Franklin #98, Colonia
Escandon, C.P. 11800, México, D.F.

eRAD PACS Viewer

eRAD PACS Viewer is a comprehensive, full-functioned medical imaging software application. The eRAD PACS Viewer is an integral part of Classic Edition, Enterprise Edition, and PACS PAL. This viewer provides:

- Common user interface for enterprise, clinical, and teleradiology environments
- Customizable user profiles that automatically follow the user to any workstation
- Sophisticated display and processing modules for specialty imaging
 - Mammography
 - Mask subtraction
 - AVI file creation
 - MPR and 3D
 - Orthopedic templating
- Integrated reporting capabilities
 - Digital Dictation, canned reports and speech recognition
 - Transcription interface and tools
 - Batch approval
 - Immediate access to all users with appropriate rights
 - Auto-notification, auto-print
- User configurable compression using progressive streaming technology for smooth image loading

