



State of West Virginia  
 Department of Administration  
 Purchasing Division  
 2019 Washington Street East  
 Post Office Box 50130  
 Charleston, WV 25305-0130

# Request for Quotation

RFQ NUMBER
BVH312

PAGE
1

ADDRESS CORRESPONDENCE TO ATTENTION OF
JOHN ABBOTT 304-558-2544

VENDOR

\*709035634      304-346-0521  
 HOOTEN EQUIPMENT COMPANY LLC  
 PO BOX 109  
 CHARLESTON WV 25321

SHIP TO

WEST VIRGINIA VETERANS HOME  
 512 WATER STREET  
 BARBOURSVILLE, WV  
 25504      736-1027

DATE PRINTED	TERMS OF SALE	SHIP VIA	F.O.B	FREIGHT TERMS
08/01/2007			Destination	

BID OPENING DATE: 08/16/2007      BID OPENING TIME 01:30PM

LINE	QUANTITY	UOP	CAT NO	ITEM NUMBER	UNIT PRICE	AMOUNT
0001	1	LS		370-99		
<p style="text-align: center;"><b>REQUEST FOR QUOTATION</b></p> <p>THE PURCHASING DIVISION IS SOLICITING BIDS FOR THE WEST VIRGINIA VETERANS HOME, BARBOURSVILLE, WV, TO PROVIDE FOOD SERVICE EQUIPMENT.</p> <p>DELIVERY: DELIVERY SHALL BE INCLUDED IN THE BID PRICE.          ASSEMBLY: ALL EQUIPMENT SHALL BE ASSEMBLED AND READY TO OPERATE UPON DELIVERY.</p> <p>ATTACHMENTS: 1. SPECIFICATIONS          2. BID FORM          3. PURCHASING AFFIDAVIT</p> <p>EQUIPMENT: FOOD SERVICE</p> <p style="text-align: center;"><b>VENDOR PREFERENCE CERTIFICATE</b></p> <p>CERTIFICATION AND APPLICATION* IS HEREBY MADE FOR PREFERENCE IN ACCORDANCE WITH WEST VIRGINIA CODE, 5A-3-37 (DOES NOT APPLY TO CONSTRUCTION CONTRACTS).</p> <p>A. APPLICATION IS MADE FOR 2.5% PREFERENCE FOR THE REASON CHECKED:</p> <p>( ) BIDDER IS AN INDIVIDUAL RESIDENT VENDOR AND HAS RESIDED CONTINUOUSLY IN WEST VIRGINIA FOR FOUR (4) YEARS IMMEDIATELY PRECEDING THE DATE OF THIS</p>						

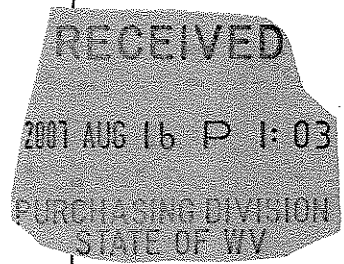

SEE REVERSE SIDE FOR TERMS AND CONDITIONS		
SIGNATURE: <i>Mark A. Hooten</i>	TELEPHONE: (304) 346-0521	DATE: 08/16/2007
TITLE: Vice President	FEIN: 20-196-1955	ADDRESS CHANGES TO BE NOTED ABOVE

WHEN RESPONDING TO RFQ, INSERT NAME AND ADDRESS IN SPACE ABOVE LABELED 'VENDOR'



State of West Virginia  
 Department of Administration  
 Purchasing Division  
 2019 Washington Street East  
 Post Office Box 50130  
 Charleston, WV 25305-0130

# Request for Quotation

RFQ NUMBER  
**BVH312**

PAGE  
**2**

ADDRESS CORRESPONDENCE TO ATTENTION OF  
**JOHN ABBOTT**  
**304-558-2544**

VENDOR

\*709035634      304-346-0521  
 HOOTEN EQUIPMENT COMPANY LLC  
 PO BOX 109  
 CHARLESTON WV 25321

SHIP TO

WEST VIRGINIA VETERANS HOME  
 512 WATER STREET  
 BARBOURSVILLE, WV  
 25504      736-1027

DATE PRINTED	TERMS OF SALE	SHIP VIA	F.O.B.	FREIGHT TERMS
08/01/2007				

BID OPENING DATE: **08/16/2007**      BID OPENING TIME **01:30PM**

LINE	QUANTITY	UOP	CAT NO	ITEM NUMBER	UNIT PRICE	AMOUNT
<p>CERTIFICATION; OR</p> <p>( X ) BIDDER IS A PARTNERSHIP, ASSOCIATION OR CORPORATION RESIDENT VENDOR AND HAS MAINTAINED ITS HEAD-QUARTERS OR PRINCIPAL PLACE OF BUSINESS CONTINUOUSLY IN WEST VIRGINIA FOR FOUR (4) YEARS IMMEDIATELY PRECEDING THE DATE OF THIS CERTIFICATION; OR 80% OF THE OWNERSHIP INTEREST OF BIDDER IS HELD BY ANOTHER INDIVIDUAL, PARTNERSHIP, ASSOCIATION OR CORPORATION RESIDENT VENDOR WHO HAS MAINTAINED ITS HEADQUARTERS OR PRINCIPAL PLACE OF BUSINESS CONTINUOUSLY IN WEST VIRGINIA FOR FOUR (4) YEARS IMMEDIATELY PRECEDING THE DATE OF THIS CERTIFICATION; OR</p> <p>( ) BIDDER IS A CORPORATION NONRESIDENT VENDOR WHICH HAS AN AFFILIATE OR SUBSIDIARY WHICH EMPLOYS A MINIMUM OF ONE HUNDRED STATE RESIDENTS AND WHICH HAS MAINTAINED ITS HEADQUARTERS OR PRINCIPAL PLACE OF BUSINESS WITHIN WEST VIRGINIA CONTINUOUSLY FOR THE FOUR (4) YEARS IMMEDIATELY PRECEDING THE DATE OF THIS CERTIFICATION.</p> <p>B. APPLICATION IS MADE FOR 2.5% PREFERENCE FOR THE REASON CHECKED:</p> <p>( X ) BIDDER IS A RESIDENT VENDOR WHO CERTIFIES THAT, DURING THE LIFE OF THE CONTRACT, ON AVERAGE AT LEAST 75% OF THE EMPLOYEES WORKING ON THE PROJECT BEING BID ARE RESIDENTS OF WEST VIRGINIA WHO HAVE RESIDED IN THE STATE CONTINUOUSLY FOR THE TWO YEARS IMMEDIATELY PRECEDING SUBMISSION OF THIS BID;  OR  ( ) BIDDER IS A NONRESIDENT VENDOR EMPLOYING A MINIMUM OF ONE HUNDRED STATE RESIDENTS OR IS A NONRESIDENT VENDOR WITH AN AFFILIATE OR SUBSIDIARY WHICH MAINTAINS ITS HEADQUARTERS OR PRINCIPAL PLACE</p>						

SEE REVERSE SIDE FOR TERMS AND CONDITIONS

SIGNATURE	TELEPHONE	DATE
TITLE	FEIN	ADDRESS CHANGES TO BE NOTED ABOVE

WHEN RESPONDING TO RFQ, INSERT NAME AND ADDRESS IN SPACE ABOVE LABELED 'VENDOR'



State of West Virginia  
 Department of Administration  
 Purchasing Division  
 2019 Washington Street East  
 Post Office Box 50130  
 Charleston, WV 25305-0130

# Request for Quotation

RFQ NUMBER  
**BVH312**

PAGE  
**3**

ADDRESS CORRESPONDENCE TO ATTENTION OF  
**JOHN ABBOTT**  
**304-558-2544**

PROPERTY

\*709035634      304-346-0521  
 HOOTEN EQUIPMENT COMPANY LLC  
 PO BOX 109  
 CHARLESTON WV 25321

SHIP TO

WEST VIRGINIA VETERANS HOME  
 512 WATER STREET  
 BARBOURSVILLE, WV  
 25504      736-1027

DATE PRINTED	TERMS OF SALE	SHIP VIA	F.O.B.	FREIGHT TERMS
08/01/2007				

BID OPENING DATE: **08/16/2007**      BID OPENING TIME **01:30PM**

LINE	QUANTITY	UOP	CAT NO	ITEM NUMBER	UNIT PRICE	AMOUNT
<p>OF BUSINESS WITHIN WEST VIRGINIA EMPLOYING A MINIMUM OF ONE HUNDRED STATE RESIDENTS WHO CERTIFIES THAT, DURING THE LIFE OF THE CONTRACT, ON AVERAGE AT LEAST 75% OF THE EMPLOYEES OR BIDDERS' AFFILIATE'S OR SUBSIDIARY'S EMPLOYEES ARE RESIDENTS OF WEST VIRGINIA WHO HAVE RESIDED IN THE STATE CONTINUOUSLY FOR THE TWO YEARS IMMEDIATELY PRECEDING SUBMISSION OF THIS BID.</p> <p>BIDDER UNDERSTANDS IF THE SECRETARY OF TAX &amp; REVENUE DETERMINES THAT A BIDDER RECEIVING PREFERENCE HAS FAILED TO CONTINUE TO MEET THE REQUIREMENTS FOR SUCH PREFERENCE, THE SECRETARY MAY ORDER THE DIRECTOR OF PURCHASING TO: (A) RESCIND THE CONTRACT OR PURCHASE ORDER ISSUED; OR (B) ASSESS A PENALTY AGAINST SUCH BIDDER IN AN AMOUNT NOT TO EXCEED 5% OF THE BID AMOUNT AND THAT SUCH PENALTY WILL BE PAID TO THE CONTRACTING AGENCY OR DEDUCTED FROM ANY UNPAID BALANCE ON THE CONTRACT OR PURCHASE ORDER.</p> <p>BY SUBMISSION OF THIS CERTIFICATE, BIDDER AGREES TO DISCLOSE ANY REASONABLY REQUESTED INFORMATION TO THE PURCHASING DIVISION AND AUTHORIZES THE DEPARTMENT OF TAX AND REVENUE TO DISCLOSE TO THE DIRECTOR OF PURCHASING APPROPRIATE INFORMATION VERIFYING THAT BIDDER HAS PAID THE REQUIRED BUSINESS TAXES, PROVIDED THAT SUCH INFORMATION DOES NOT CONTAIN THE AMOUNTS OF TAXES PAID NOR ANY OTHER INFORMATION DEEMED BY THE TAX COMMISSIONER TO BE CONFIDENTIAL.</p> <p>UNDER PENALTY OF LAW FOR FALSE SWEARING (WEST VIRGINIA CODE 61-5-3), BIDDER HEREBY CERTIFIES THAT THIS CERTIFICATE IS TRUE AND ACCURATE IN ALL RESPECTS; AND THAT IF A CONTRACT IS ISSUED TO BIDDER AND IF ANYTHING CONTAINED WITHIN THIS CERTIFICATE CHANGES DURING THE TERM OF THE CONTRACT, BIDDER WILL NOTIFY THE PURCHASING DIVISION IN WRITING IMMEDIATELY.</p>						

SEE REVERSE SIDE FOR TERMS AND CONDITIONS

SIGNATURE	TELEPHONE	DATE
TITLE	FEIN	ADDRESS CHANGES TO BE NOTED ABOVE

WHEN RESPONDING TO RFQ, INSERT NAME AND ADDRESS IN SPACE ABOVE LABELED 'VENDOR'



State of West Virginia  
 Department of Administration  
 Purchasing Division  
 2019 Washington Street East  
 Post Office Box 50130  
 Charleston, WV 25305-0130

# Request for Quotation

RFQ NUMBER  
**BVH312**

PAGE  
**4**

ADDRESS CORRESPONDENCE TO ATTENTION OF  
**JOHN ABBOTT**  
**304-558-2544**

VENDOR

\*709035634      304-346-0521  
**HOOTEN EQUIPMENT COMPANY LLC**  
**PO BOX 109**  
  
**CHARLESTON WV 25321**

SHIP TO

**WEST VIRGINIA VETERANS HOME**  
  
**512 WATER STREET**  
**BARBOURSVILLE, WV**  
**25504                      736-1027**

DATE PRINTED <b>08/01/2007</b>	TERMS OF SALE	SHIP VIA	F.O.B.	FREIGHT TERMS
-----------------------------------	---------------	----------	--------	---------------

BID OPENING DATE: **08/16/2007**      BID OPENING TIME **01:30PM**

LINE	QUANTITY	UOP	CAT NO	ITEM NUMBER	UNIT PRICE	AMOUNT
<p>BIDDER: <u>Hooten Equipment Company LLC</u></p> <p>DATE: <u>08/16/2007</u></p> <p>SIGNED: <u><i>Mark D. Hillis</i></u></p> <p>TITLE: <u>Vice President</u></p> <p>* CHECK ANY COMBINATION OF PREFERENCE CONSIDERATION(S) IN EITHER "A" OR "B", OR BOTH "A" AND "B" WHICH YOU ARE ENTITLED TO RECEIVE. YOU MAY REQUEST UP TO THE MAXIMUM 5% PREFERENCE FOR BOTH "A" AND "B". (REV. 12/00)</p> <p>NOTICE</p> <p>A SIGNED BID MUST BE SUBMITTED TO:</p> <p>DEPARTMENT OF ADMINISTRATION          PURCHASING DIVISION          BUILDING 15          2019 WASHINGTON STREET, EAST          CHARLESTON, WV 25305-0130</p> <p>THE BID SHOULD CONTAIN THIS INFORMATION ON THE FACE OF THE ENVELOPE OR THE BID MAY NOT BE CONSIDERED:</p> <p>SEALED BID</p>						

SEE REVERSE SIDE FOR TERMS AND CONDITIONS

SIGNATURE	TELEPHONE	DATE
TITLE	FEIN	ADDRESS CHANGES TO BE NOTED ABOVE

WHEN RESPONDING TO RFQ, INSERT NAME AND ADDRESS IN SPACE ABOVE LABELED 'VENDOR'



State of West Virginia  
 Department of Administration  
 Purchasing Division  
 2019 Washington Street East  
 Post Office Box 50130  
 Charleston, WV 25305-0130

# Request for Quotation

RFQ NUMBER  
**BVH312**

PAGE  
**5**

ADDRESS CORRESPONDENCE TO ATTENTION OF  
**JOHN ABBOTT**  
**304-558-2544**

VENDOR

\*709035634      304-346-0521  
 HOOTEN EQUIPMENT COMPANY LLC  
 PO BOX 109  
 CHARLESTON WV 25321

SHIP TO

WEST VIRGINIA VETERANS HOME  
 512 WATER STREET  
 BARBOURSVILLE, WV  
 25504      736-1027

DATE PRINTED	TERMS OF SALE	SHIP VIA	F.O.B.	FREIGHT TERMS
08/01/2007				

BID OPENING DATE: **08/16/2007**      BID OPENING TIME **01:30PM**

LINE	QUANTITY	UOP	CAT NO	ITEM NUMBER	UNIT PRICE	AMOUNT
BUYER:				JOHN ABBOTT	-----	
RFQ. NO.:				BVH312	-----	
BID OPENING DATE:				08/16/2007	-----	
BID OPENING TIME:				1:30 PM	-----	
PLEASE PROVIDE A FAX NUMBER IN CASE IT IS NECESSARY TO CONTACT YOU REGARDING YOUR BID:						
				(304)346-3421	-----	
CONTACT PERSON (PLEASE PRINT CLEARLY):						
				Mark K. Williams	-----	
***** THIS IS THE END OF RFQ      BVH312 ***** TOTAL:						\$ 71,625.00

SEE REVERSE SIDE FOR TERMS AND CONDITIONS

SIGNATURE	TELEPHONE	DATE
TITLE	FEIN	ADDRESS CHANGES TO BE NOTED ABOVE

WHEN RESPONDING TO RFQ, INSERT NAME AND ADDRESS IN SPACE ABOVE LABELED 'VENDOR'

**BVH312 - Food Service Equipment - BID FORM**

Item Number	Description	Order Qty.	Bid Price
1	Buffet	1	\$ 10,884.73
2	Counter	1	\$ 7,143.83
3	Serving Counter	1	\$ 4,641.23
4	Display Case	1	\$ 5,567.63
5	Serving Counter - Cold Pan	1	\$ 5,319.11
6	Serving Counter - Hot Food	1	\$ 3,906.53
7	Tray Slide	1	\$ 512.27
8	Sneeze Guard	1	\$ 3,037.02
9	Gas Fryer	1	\$ 6,200.98
10	Tilting Skillet	1	\$ 11,194.02
11	Soft Serve Machine	1	\$ 13,217.65

<b>Failure to use this form may result in disqualification</b>			<b>Total \$71,625.00</b>
--	--	--	--------------------------

<b>Bidder / Vendor Information:</b>	
Name:	<u>Hooten Equipment Company LLC</u>
Address:	<u>961 Virginia Street, West</u> <u>Charleston, WV 25302</u>
Phone# :	<u>(304)346-0521</u>
Email Address:	<u>hootenequipmentcompany.com</u>
<b>Contract Coordinator Information:</b>	
Name:	<u>Mark K. Williams</u>
Address:	<u>961 Virginia Street, West</u> <u>Charleston, WV 25302</u>
Phone# :	<u>(304)346-0521</u>
Email Address:	<u>mark@hootenequipmentcompany.com</u>

STATE OF WEST VIRGINIA  
Purchasing Division

**PURCHASING AFFIDAVIT**

**West Virginia Code §5A-3-10a states:** No contract or renewal of any contract may be awarded by the state or any of its political subdivisions to any vendor or prospective vendor when the vendor or prospective vendor or a related party to the vendor or prospective vendor is a debtor and the debt owned is an amount greater than one thousand dollars in the aggregate

**DEFINITIONS:**

“Debt” means any assessment, premium, penalty, fine, tax or other amount of money owed to the state or any of its political subdivisions because of a judgment, fine, permit violation, license assessment, defaulted workers’ compensation premium, penalty or other assessment presently delinquent or due and required to be paid to the state or any of its political subdivisions, including any interest or additional penalties accrued thereon.

“Debtor” means any individual, corporation, partnership, association, limited liability company or any other form or business association owing a debt to the state or any of its political subdivisions. “Political subdivision” means any county commission; municipality; county board of education; any instrumentality established by a county or municipality; any separate corporation or instrumentality established by one or more counties or municipalities, as permitted by law; or any public body charged by law with the performance of a government function or whose jurisdiction is coextensive with one or more counties or municipalities. “Related party” means a party, whether an individual, corporation, partnership, association, limited liability company or any other form or business association or other entity whatsoever, related to any vendor by blood, marriage, ownership or contract through which the party has a relationship of ownership or other interest with the vendor so that the party will actually or by effect receive or control a portion of the benefit, profit or other consideration from performance of a vendor contract with the party receiving an amount that meets or exceed five percent of the total contract amount.

**EXCEPTION:** The prohibition of this section does not apply where a vendor has contested any tax administered pursuant to chapter eleven of this code, workers’ compensation premium, permit fee or environmental fee or assessment and the matter has not become final or where the vendor has entered into a payment plan or agreement and the vendor is not in default of any of the provisions of such plan or agreement.

**LICENSING:** Vendors must be licensed and in good standing in accordance with any and all state and local laws and requirements by any state or local agency of West Virginia, including, but not limited to, the West Virginia Secretary of State’s Office, the West Virginia Tax Department, West Virginia Insurance Commission, or any other state agencies or political subdivision. Furthermore, the vendor must provide all necessary releases to obtain information to enable the Director or spending unit to verify that the vendor is licensed and in good standing with the above entities.

**CONFIDENTIALITY:** The vendor agrees that he or she will not disclose to anyone, directly or indirectly, any such personally identifiable information or other confidential information gained from the agency, unless the individual who is the subject of the information consents to the disclosure in writing or the disclosure is made pursuant to the agency’s policies, procedures and rules. Vendors should visit [www.state.wv.us/admin/purchase/privacy](http://www.state.wv.us/admin/purchase/privacy) for the Notice of Agency Confidentiality Policies.

Under penalty of law for false swearing (West Virginia Code, §61-5-3), it is hereby certified that the vendor acknowledges the information in this said affidavit and are in compliance with the requirements as stated.

Vendor’s Name: Hooten Equipment Company LLC

Authorized Signature:  Date: 08/16/2007

Mark K. Williams, Vice President

## WV Veterans Home

### PRICING INCLUDES:

1. Manufacturer's freight charges.
2. Delivery, uncrating, setting in place and made ready for final utility and drain connections by others.
3. Manufacturer's warranty to apply.
4. Pricing does not include 6% WV sales tax.

\* NOTE: Installation based on Hooten Equipment Company standard wage rates and normal business working hours 8:00 am - 5:00 pm M-F. If WV prevailing wage rates apply for installation add to base bid.

ADD: \$ 500.00

Hooten Equipment Co.- Charleston





a Standex company

Item 4

**SERIES '90**  
**NON-REFRIG. BAKERY CASE**  
**MODEL SN-48**  
**SN-59**  
**SN-77**

*(Alternate:)*

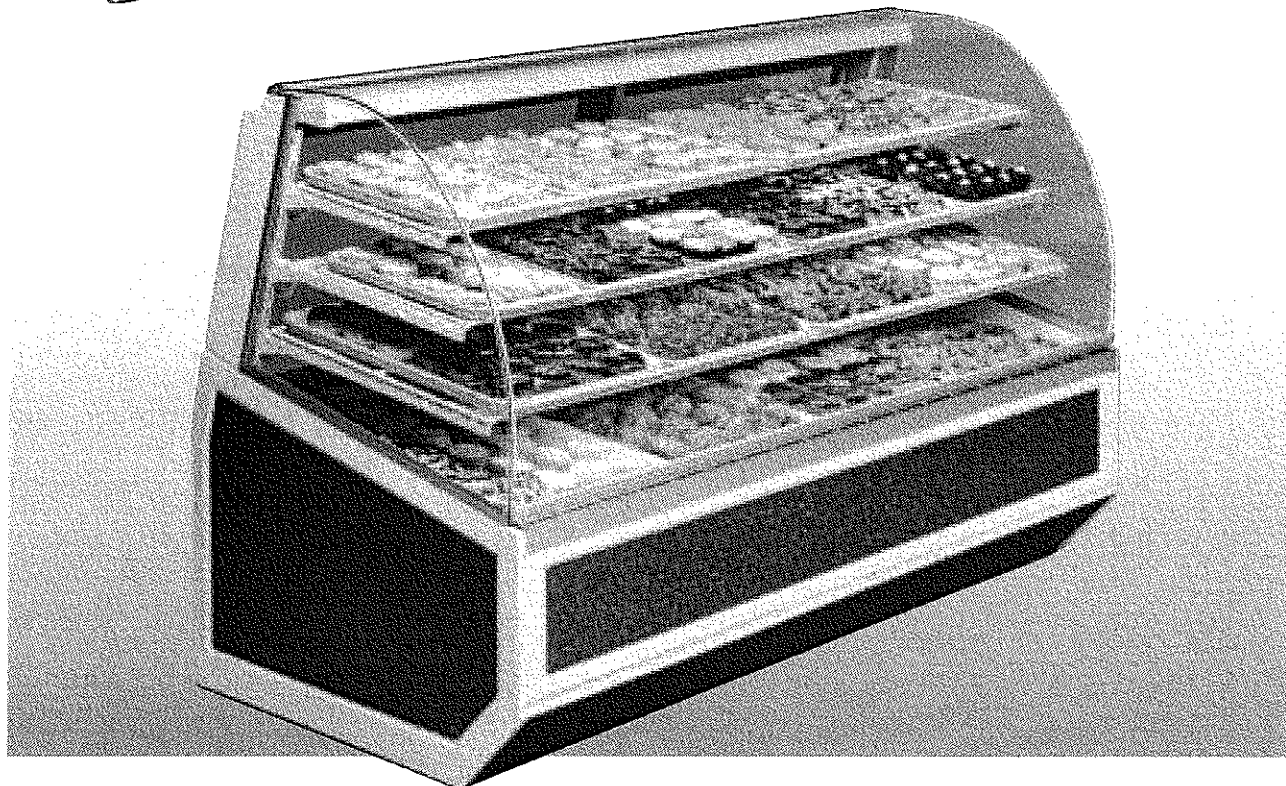

*Series '90. The ultimate merchandiser with advanced styling for maximum visual appeal. Cases are available in lengths of 48", 59", and 77". Designed for continuous case line-ups.*

#### STANDARD FEATURES

- Adjustable white cantilevered shelves. Shelves are adjustable up and down and can also be tilted.
- Lift-up pneumatic, cylinder-assisted double-curve tempered front glass.
- Four point leveling system.
- Removable sliding rear doors, shelf lights, shelf supports, and shelves.
- Glass ends and rear doors. Rear doors are sloped for product access.
- Vent system to reduce heat build-up from the lights.
- Octron top light and shelf lights. Lights are shielded and independently wired.
- All-welded base construction with a choice of six standard laminates on base. Other color laminates optional.
- Easily accessible control panel with main auxiliary fan and light control.
- Neutral beige acrylic PVC trim. Trim does not show scratches and is very easy to clean.
- Double bend tempered front glass reduces glare from outside lighting.
- Case height is only 48" high allowing better interaction between the customer and the sales clerk.
- White display deck.
- UL Safety and NSF Listed.

## SERIES '90 NON-REFRIGERATED BAKERY CASE

**OPTIONAL ACCESSORIES:**

- \* Package Shelf
- \* Glass Shelves
- \* Reflective Rear Doors
- \* Special Base Finish
- \* Light Below Package Shelf
- \* Special Trim
- \* Reflective Ends
- \* Rear Wrapping Board
- \* Cord and Plug (NEMA 5-15)
- \* Casters or Legs
- \* Front Glass and Rear Door Locks
- \* Black, Chrome, or Gold Wire Shelves
- \* Black Interior
- \* Top Service Shelf

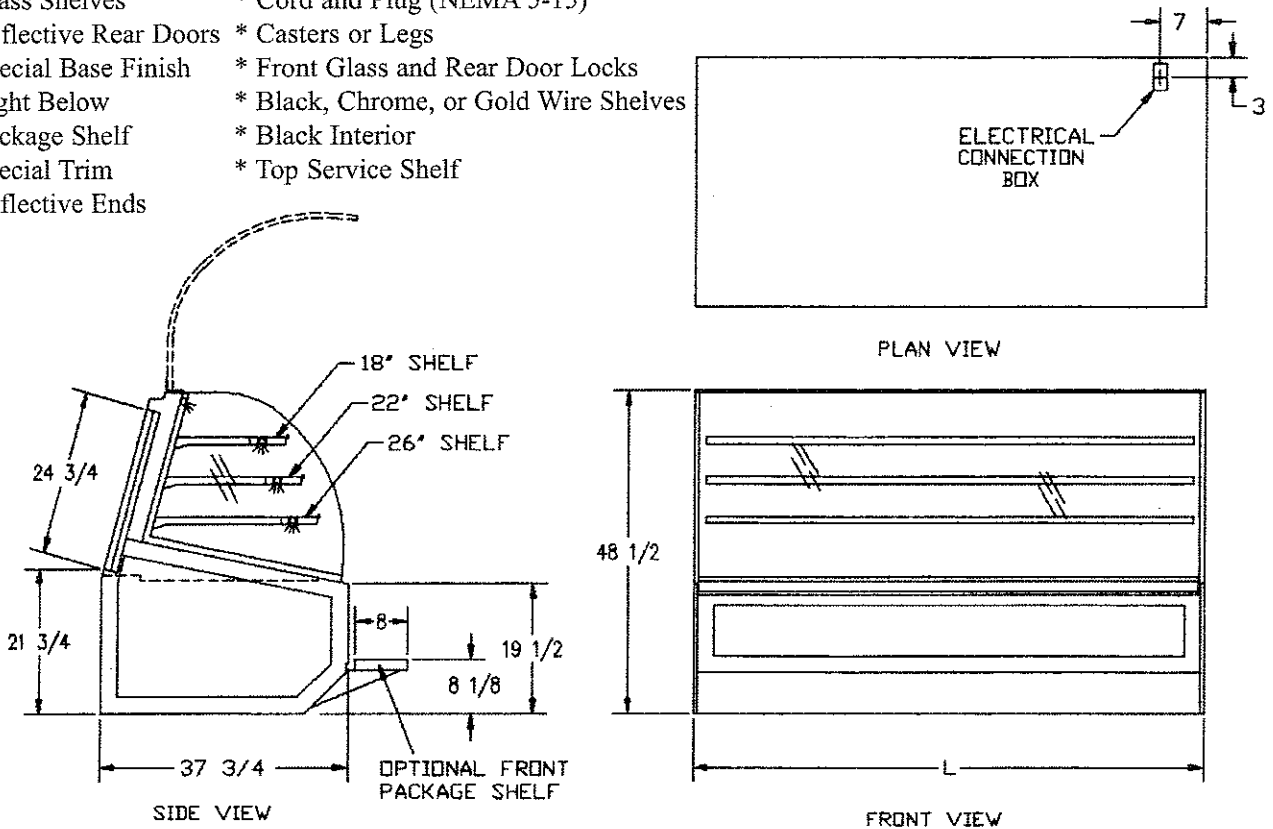

**SPECIFICATIONS:**

Model	Dimensions			Shipping Weight (lbs)	Capacity (Bakery Pans)	Power 120/60/1
	L	W	H			
SN-48	48 1/4" x 37 3/4" x 48 1/2"			600	4 (18" x 26") 8 (12" x 18") 2 (9" x 26")	1.0 AMPS
SN-59	59 1/4" x 37 3/4" x 48 1/2"			700	10 (18" x 26")	1.5 AMPS
SN-77	77 1/4" x 37 3/4" x 48 1/2"			865	8 (18" x 26") 12 (12" x 18")	2.0 AMPS



- Due to continuing engineering improvements, specifications are subject to change without notice.

**Look to Federal for Innovative Merchandising**

**Federal Industries**  
**A Standex Company**  
 215 Federal Avenue  
 Belleville WI 53508-0290  
 Phone: 800-356-4206  
 Fax: 608-424-3234  
 Email: [geninfo@federalind.com](mailto:geninfo@federalind.com)  
 Web Site: [www.federalind.com](http://www.federalind.com)

