



State of West Virginia
 Department of Administration
 Purchasing Division
 2019 Washington Street East

**Request for
 Quotation**

RFQ NUMBER
AUD093322

PAGE
1

SHARP

CGO CompTIA
 CDIA+ Certified

ADDRESS CORRESPONDENCE TO ATTENTION OF
FRANK WHITTAKER 304-558-2316

GARY THOMPSON

GOVERNMENT ACCOUNT EXECUTIVE
 CDIA+



SHARP ELECTRONICS CORPORATION
 SHARP IMAGING AND INFORMATION COMPANY OF AMERICA
 SHARP PLAZA, MAHWAH, NEW JERSEY 07495-1163
 PHONE: 614-883-4163 FAX: 614-737-5301
 CELL: 614-260-2285
 E-MAIL: THOMPSON@SHARPAmericas.COM
 WWW.SHARPU.SA.COM

STATE AUDITOR'S OFFICE

**RECORDS MGMT FACILITY
 4916 KANAWHA BLVD E
 MALDEN, WV
 25306-6330 304-926-1717**

DATE PRINTED	TERMS OF SALE	SHIP VIA	FOB	FREIGHT TERMS
05/12/2008				

BID OPENING DATE: **06/03/2008** BID OPENING TIME **01:30PM**

LINE	QUANTITY	UOP	CAT NO	ITEM NUMBER	UNIT PRICE	AMOUNT
0001	1	EA		985-26-28-001		
<p>SHIP TO : STATE AUDITOR'S OFFICE BUILDING 1, ROOM W100 1900 KANAWHA BOULEVARD, EAST CHARLESTON, WV 25305-0230 558-2251</p> <p>THE WEST VIRGINIA PURCHASING DIVISION, FOR THE WV STATE AUDITORS OFFICE, IS SOLICITING BIDS FROM QUALIFIED AND RESPONSIBLE VENDORS TO PROVIDE A COPIER/NETWORK PRINTER PER THE ATTACHED SPECIFICATIONS.</p> <p>BANKRUPTCY: IN THE EVENT THE VENDOR/CONTRACTOR FILES FOR BANKRUPTCY PROTECTION, THIS CONTRACT MAY BE DEEMED NULL AND VOID, AND TERMINATED WITHOUT FURTHER ORDER.</p> <p>VENDOR PREFERENCE CERTIFICATE</p> <p>CERTIFICATION AND APPLICATION* IS HEREBY MADE FOR PREFERENCE IN ACCORDANCE WITH WEST VIRGINIA CODE, SA-3-37 (DOES NOT APPLY TO CONSTRUCTION CONTRACTS).</p> <p>A. APPLICATION IS MADE FOR 2.5% PREFERENCE FOR THE REASON CHECKED:</p> <p>() BIDDER IS AN INDIVIDUAL RESIDENT VENDOR AND HAS RESIDED CONTINUOUSLY IN WEST VIRGINIA FOR FOUR (4) YEARS IMMEDIATELY PRECEDING THE DATE OF THIS</p>						

RECEIVED

2008 JUN -3 A 8:19

PURCHASING DIVISION
 STATE OF WV

SEE REVERSE SIDE FOR TERMS AND CONDITIONS

SIGNATURE	TELEPHONE	DATE
TITLE	FEIN	ADDRESS CHANGES TO BE NOTED ABOVE

WHEN RESPONDING TO RFQ, INSERT NAME AND ADDRESS IN SPACE ABOVE LABELED 'VENDOR'

**GENERAL TERMS & CONDITIONS
REQUEST FOR QUOTATION (RFQ) AND REQUEST FOR PROPOSAL (RFP)**

1. Awards will be made in the best interest of the State of West Virginia.
2. The State may accept or reject in part, or in whole, any bid.
3. All quotations are governed by the *West Virginia Code* and the *Legislative Rules* of the Purchasing Division.
4. Prior to any award, the apparent successful vendor must be properly registered with the Purchasing Division and have paid the required \$125.00 registration fee.
5. All services performed or goods delivered under State Purchase Orders/Contracts are to be continued for the term of the Purchase Order/Contract, contingent upon funds being appropriated by the Legislature or otherwise being made available. In the event funds are not appropriated or otherwise available for these services or goods, this Purchase Order/Contract becomes void and of no effect after June 30.
6. Payment may only be made after the delivery and acceptance of goods or services.
7. Interest may be paid for late payment in accordance with the *West Virginia Code*.
8. Vendor preference will be granted upon written request in accordance with the *West Virginia Code*.
9. The State of West Virginia is exempt from federal and state taxes and will not pay or reimburse such taxes.
10. The Director of Purchasing may cancel any Purchase Order/Contract upon 30 days written notice to the seller.
11. The laws of the State of West Virginia and the *Legislative Rules* of the Purchasing Division shall govern all rights and duties under the Contract, including without limitation the validity of this Purchase Order/Contract.
12. Any reference to automatic renewal is hereby deleted. The Contract may be renewed only upon mutual written agreement of the parties.
13. **BANKRUPTCY:** In the event the vendor/contractor files for bankruptcy protection, this Contract may be deemed null and void, and terminated without further order.
14. **HIPAA Business Associate Addendum** - The West Virginia State Government HIPAA Business Associate Addendum (BAA), approved by the Attorney General, and available online at the Purchasing Division's web site (<http://www.state.wv.us/admin/purchase/vrc/hipaa.htm>) is hereby made part of the agreement. Provided that, the Agency meets the definition of a Covered Entity (45 CFR §160.103) and will be disclosing Protected Health Information (45 CFR §160.103) to the vendor.

INSTRUCTIONS TO BIDDERS

1. Use the quotation forms provided by the Purchasing Division.
2. **SPECIFICATIONS:** Items offered must be in compliance with the specifications. Any deviation from the specifications must be clearly indicated by the bidder. Alternates offered by the bidder as **EQUAL** to the specifications must be clearly defined. A bidder offering an alternate should attach complete specifications and literature to the bid. The Purchasing Division may waive minor deviations to specifications.
3. Complete all sections of the quotation form.
4. Unit prices shall prevail in cases of discrepancy.
5. All quotations are considered F.O.B. destination unless alternate shipping terms are clearly identified in the quotation.
6. **BID SUBMISSION:** All quotations must be delivered by the bidder to the office listed below prior to the date and time of the bid opening. Failure of the bidder to deliver the quotations on time will result in bid disqualifications.

SIGNED BID TO:

Department of Administration
Purchasing Division
2019 Washington Street East
Post Office Box 50130
Charleston, WV 25305-0130



State of West Virginia
 Department of Administration
 Purchasing Division
 2019 Washington Street East
 Post Office Box 50130
 Charleston, WV 25305-0130

Request for Quotation

RFQ NUMBER
AUD093322

PAGE
2

ADDRESS CORRESPONDENCE TO ATTENTION OF
**FRANK WHITTAKER
 304-558-2316**

RFQ COPY
 TYPE NAME/ADDRESS HERE

STATE AUDITOR'S OFFICE
 RECORDS MGMT FACILITY
 4916 KANAWHA BLVD E
 MALDEN, WV
 25306-6330 304-926-1717

DATE PRINTED	TERMS OF SALE	SHIP VIA	FOB	FREIGHT TERMS
05/12/2008				

BID OPENING DATE: **06/03/2008** BID OPENING TIME **01:30PM**

LINE	QUANTITY	LOF	CAT NO	ITEM NUMBER	UNIT PRICE	AMOUNT
<p>CERTIFICATION; OR</p> <p>() BIDDER IS A PARTNERSHIP, ASSOCIATION OR CORPORATION RESIDENT VENDOR AND HAS MAINTAINED ITS HEAD-QUARTERS OR PRINCIPAL PLACE OF BUSINESS CONTINUOUSLY IN WEST VIRGINIA FOR FOUR (4) YEARS IMMEDIATELY PRECEDING THE DATE OF THIS CERTIFICATION; OR 80% OF THE OWNERSHIP INTEREST OF BIDDER IS HELD BY ANOTHER INDIVIDUAL, PARTNERSHIP, ASSOCIATION OR CORPORATION RESIDENT VENDOR WHO HAS MAINTAINED ITS HEADQUARTERS OR PRINCIPAL PLACE OF BUSINESS CONTINUOUSLY IN WEST VIRGINIA FOR FOUR (4) YEARS IMMEDIATELY PRECEDING THE DATE OF THIS CERTIFICATION; OR</p> <p>() BIDDER IS A CORPORATION NONRESIDENT VENDOR WHICH HAS AN AFFILIATE OR SUBSIDIARY WHICH EMPLOYS A MINIMUM OF ONE HUNDRED STATE RESIDENTS AND WHICH HAS MAINTAINED ITS HEADQUARTERS OR PRINCIPAL PLACE OF BUSINESS WITHIN WEST VIRGINIA CONTINUOUSLY FOR THE FOUR (4) YEARS IMMEDIATELY PRECEDING THE DATE OF THIS CERTIFICATION.</p> <p>B. APPLICATION IS MADE FOR 2.5% PREFERENCE FOR THE REASON CHECKED:</p> <p>() BIDDER IS A RESIDENT VENDOR WHO CERTIFIES THAT, DURING THE LIFE OF THE CONTRACT, ON AVERAGE AT LEAST 75% OF THE EMPLOYEES WORKING ON THE PROJECT BEING BID ARE RESIDENTS OF WEST VIRGINIA WHO HAVE RESIDED IN THE STATE CONTINUOUSLY FOR THE TWO YEARS IMMEDIATELY PRECEDING SUBMISSION OF THIS BID;</p> <p>OR</p> <p>() BIDDER IS A NONRESIDENT VENDOR EMPLOYING A MINIMUM OF ONE HUNDRED STATE RESIDENTS OR IS A NONRESIDENT VENDOR WITH AN AFFILIATE OR SUBSIDIARY WHICH MAINTAINS ITS HEADQUARTERS OR PRINCIPAL PLACE</p>						

SEE REVERSE SIDE FOR TERMS AND CONDITIONS

SIGNATURE	TELEPHONE	DATE
TITLE	FEIN	ADDRESS CHANGES TO BE NOTED ABOVE

WHEN RESPONDING TO RFQ, INSERT NAME AND ADDRESS IN SPACE ABOVE LABELED 'VENDOR'



State of West Virginia
 Department of Administration
 Purchasing Division
 2019 Washington Street East
 Post Office Box 50130
 Charleston, WV 25305-0130

**Request for
 Quotation**

RFQ NUMBER
AUD093322

PAGE
3

ADDRESS CORRESPONDENCE TO ATTENTION OF
**FRANK WHITTAKER
 304-558-2316**

RFQ COPY
 TYPE NAME/ADDRESS HERE

VENDOR

SHIP TO

STATE AUDITOR'S OFFICE
 RECORDS MGMT FACILITY
 4916 KANAWHA BLVD E
 MALDEN, WV
 25306-6330 304-926-1717

DATE PRINTED	TERMS OF SALE	SHIP VIA	FOB	FREIGHT TERMS
05/12/2008				

BID OPENING DATE: **06/03/2008** BID OPENING TIME **01:30PM**

LINE	QUANTITY	UOP	CAT NO	ITEM NUMBER	UNIT PRICE	AMOUNT
<p>OF BUSINESS WITHIN WEST VIRGINIA EMPLOYING A MINIMUM OF ONE HUNDRED STATE RESIDENTS WHO CERTIFIES THAT, DURING THE LIFE OF THE CONTRACT, ON AVERAGE AT LEAST 75% OF THE EMPLOYEES OR BIDDERS' AFFILIATE'S OR SUBSIDIARY'S EMPLOYEES ARE RESIDENTS OF WEST VIRGINIA WHO HAVE RESIDED IN THE STATE CONTINUOUSLY FOR THE TWO YEARS IMMEDIATELY PRECEDING SUBMISSION OF THIS BID.</p> <p>BIDDER UNDERSTANDS IF THE SECRETARY OF TAX & REVENUE DETERMINES THAT A BIDDER RECEIVING PREFERENCE HAS FAILED TO CONTINUE TO MEET THE REQUIREMENTS FOR SUCH PREFERENCE, THE SECRETARY MAY ORDER THE DIRECTOR OF PURCHASING TO: (A) RESCIND THE CONTRACT OR PURCHASE ORDER ISSUED; OR (B) ASSESS A PENALTY AGAINST SUCH BIDDER IN AN AMOUNT NOT TO EXCEED 5% OF THE BID AMOUNT AND THAT SUCH PENALTY WILL BE PAID TO THE CONTRACTING AGENCY OR DEDUCTED FROM ANY UNPAID BALANCE ON THE CONTRACT OR PURCHASE ORDER.</p> <p>BY SUBMISSION OF THIS CERTIFICATE, BIDDER AGREES TO DISCLOSE ANY REASONABLY REQUESTED INFORMATION TO THE PURCHASING DIVISION AND AUTHORIZES THE DEPARTMENT OF TAX AND REVENUE TO DISCLOSE TO THE DIRECTOR OF PURCHASING APPROPRIATE INFORMATION VERIFYING THAT BIDDER HAS PAID THE REQUIRED BUSINESS TAXES, PROVIDED THAT SUCH INFORMATION DOES NOT CONTAIN THE AMOUNTS OF TAXES PAID NOR ANY OTHER INFORMATION DEEMED BY THE TAX COMMISSIONER TO BE CONFIDENTIAL.</p> <p>UNDER PENALTY OF LAW FOR FALSE SWEARING (WEST VIRGINIA CODE 61-5-3), BIDDER HEREBY CERTIFIES THAT THIS CERTIFICATE IS TRUE AND ACCURATE IN ALL RESPECTS; AND THAT IF A CONTRACT IS ISSUED TO BIDDER AND IF ANYTHING CONTAINED WITHIN THIS CERTIFICATE CHANGES DURING THE TERM OF THE CONTRACT, BIDDER WILL NOTIFY THE PURCHASING DIVISION IN WRITING IMMEDIATELY.</p>						

SEE REVERSE SIDE FOR TERMS AND CONDITIONS

SIGNATURE	TELEPHONE	DATE
TITLE	FEIN	ADDRESS CHANGES TO BE NOTED ABOVE

WHEN RESPONDING TO RFQ, INSERT NAME AND ADDRESS IN SPACE ABOVE LABELED 'VENDOR'



State of West Virginia
 Department of Administration
 Purchasing Division
 2019 Washington Street East
 Post Office Box 50130
 Charleston, WV 25305-0130

Request for Quotation

RFQ NUMBER
AUD093322

PAGE
4

ADDRESS CORRESPONDENCE TO/ATTENTION OF
FRANK WHITTAKER
304-558-2316

VENDOR

RFQ COPY
 TYPE NAME/ADDRESS HERE

SHIP TO

STATE AUDITOR'S OFFICE
 RECORDS MGMT FACILITY
 4916 KANAWHA BLVD E
 MALDEN, WV
 25306-6330 304-926-1717

DATE PRINTED	TERMS OF SALE	SHIP VIA	FOB	FREIGHT TERMS
05/12/2008				

BID OPENING DATE: **06/03/2008** BID OPENING TIME **01:30PM**

LINE	QUANTITY	UOP	CAT NO	ITEM NUMBER	UNIT PRICE	AMOUNT
<p>BIDDER: <u>SHARP ELECTRONICS CORPORATION</u></p> <p>DATE: <u>JUNE 2, 2008</u></p> <p>SIGNED: <u>[Signature]</u></p> <p>TITLE: <u>GOV' ACC EXEC.</u></p> <p>* CHECK ANY COMBINATION OF PREFERENCE CONSIDERATION(S) IN EITHER "A" OR "B", OR BOTH "A" AND "B" WHICH YOU ARE ENTITLED TO RECEIVE. YOU MAY REQUEST UP TO THE MAXIMUM 5% PREFERENCE FOR BOTH "A" AND "B". (REV. 12/00)</p> <p>NOTICE</p> <p>A SIGNED BID MUST BE SUBMITTED TO:</p> <p>DEPARTMENT OF ADMINISTRATION PURCHASING DIVISION BUILDING 15 2019 WASHINGTON STREET, EAST CHARLESTON, WV 25305-0130</p> <p>THE BID SHOULD CONTAIN THIS INFORMATION ON THE FACE OF THE ENVELOPE OR THE BID MAY NOT BE CONSIDERED:</p> <p>SEALED BID</p>						

SEE REVERSE SIDE FOR TERMS AND CONDITIONS

SIGNATURE	TELEPHONE	DATE
TITLE	FERN	ADDRESS CHANGES TO BE NOTED ABOVE

WHEN RESPONDING TO RFQ, INSERT NAME AND ADDRESS IN SPACE ABOVE LABELED 'VENDOR'



State of West Virginia
 Department of Administration
 Purchasing Division
 2019 Washington Street East
 Post Office Box 50130
 Charleston, WV 25305-0130

Request for Quotation

RFQ NUMBER
AUD093322

PAGE
5

ADDRESS CORRESPONDENCE TO ATTENTION OF
**FRANK WHITTAKER
 304-558-2316**

PURCHASER

RFQ COPY
 TYPE NAME/ADDRESS HERE

SHIP TO

STATE AUDITOR'S OFFICE
 RECORDS MGMT FACILITY
 4916 KANAWHA BLVD E
 MALDEN, WV
 25306-6330 304-926-1717

DATE PRINTED	TERMS OF SALE	SHIP VIA	FOB	FREIGHT TERMS
05/12/2008				

BID OPENING DATE: **06/03/2008** BID OPENING TIME **01:30PM**

LINE	QUANTITY	UOP	CAT NO.	ITEM NUMBER	UNIT PRICE	AMOUNT
BUYER:				44		
RFQ. NO.:				AUD093322		
BID OPENING DATE:				06/03/08		
BID OPENING TIME:				1:30 PM		
PLEASE PROVIDE A FAX NUMBER IN CASE IT IS NECESSARY TO CONTACT YOU REGARDING YOUR BID:						

CONTACT PERSON (PLEASE PRINT CLEARLY):						

***** THIS IS THE END OF RFQ AUD093322 ***** TOTAL: _____						

SEE REVERSE SIDE FOR TERMS AND CONDITIONS

SIGNATURE	TELEPHONE	DATE
TITLE	FEIN	ADDRESS CHANGES TO BE NOTED ABOVE

WHEN RESPONDING TO RFQ, INSERT NAME AND ADDRESS IN SPACE ABOVE LABELED 'VENDOR'

**WV STATE AUDITOR
105 PPM COPIER RFQ
AUD093322**

GENERAL

BLACK & WHITE 105 PPM (MINIMUM) COPIER SYSTEM
STAND ALONE UNIT, NOT LINKED (I.E. 2 EA. 85 PPM UNITS)
36 MONTH LEASE
NO THIRD PARTY LEASING

REQUIRED FEATURES

NETWORK PRINTING
SCANNING (SCAN TO FILE, SCAN TO EMAIL)
2 & 3 HOLE PUNCH
PROFFESIONAL PUNCHER (PLASTIC COMB PUNCH)
5000 SHEET CAPACITY MULTI-POSITION STAPLER FINISHER
TAB INSERTS
SHEET & COVER INSERTS
100 SHEET CAPACITY DOCUMENT FEEDER

PAPER REQUIREMENTS

LEGAL (MIN) 500 SHEET PER DRAWER (SPD) CAPACITY
LEDGER (MIN) 500 SHEET SPD CAPACITY
LETTER (MIN) 3000 SHEET SPD CAPACITY
LETTER (MIN) 3500 SHEET SPD PAPER DECK CAPACITY

SERVICE

600,000 COPIES PER YEAR TO BE INCLUDED
ALL PARTS & LABOR TO BE INCLUDED
ALL SUPPLIES (EXCLUDING PAPER) TO BE INCLUDED
LIST EXCESS COPY CHARGE
MUST PROVIDE "OFF HOURS" EMERGENCY SERVICE 5:00PM - 8:00AM MONDAY
THROUGH & Friday, WEEKENDS AND HOLIDAYS

Price Sheet RFQ AUD093322

Lease/Copy Charges

- | | Per/Month | Extended |
|---|-----------------------|-------------------------------|
| ➤ 36 month lease, 50,000 copies per mo. | \$1,369 ⁰¹ | x 36 = \$49,316 ⁷⁶ |
| ➤ Monthly copy overage \$0.0048 per page x 5,000 = \$24 ⁰⁰
5,000 pages estimate for bidding purposes only | | x 36 = \$864 ⁰⁰ |

Services

- "Off hours" Service Rate \$165⁰⁰ per/hr x 5hr per year x 3 years \$975⁰⁰
5:00 pm – 8:00 AM Monday through Friday, holidays and weekends
Quantities are estimated for bidding purposes only.

TOTAL BID: \$51,155⁷⁶

Quantities for overages and off hour services are estimates for bidding purposes only; actual quantities will vary. All overages and off hour services are to be billed at the bid unit price.

Monthly lease rates and unit price for overages are to be fixed for the life of the contract.

PROPOSED EQUIPMENT VARIES FROM SPECIFICATIONS
AS FOLLOWS:

- STAPLER FINISHER CAPACITY IS 3,500 SHEETS
- PAPER SUPPLY FOR LETTER SIZE PAPER IS
2 X 1,000 + 4,500-SHEET LARGE CAPACITY PAPER DECK (3-DRAWER)
AND 2-USER ADJUSTABLE 500-SHEET DRAWERS PLUS A
500-SHEET STACK BYPASS

STATE OF WEST VIRGINIA
Purchasing Division**PURCHASING AFFIDAVIT**

West Virginia Code §5A-3-10a states: No contract or renewal of any contract may be awarded by the state or any of its political subdivisions to any vendor or prospective vendor when the vendor or prospective vendor or a related party to the vendor or prospective vendor is a debtor and the debt owed is an amount greater than one thousand dollars in the aggregate

DEFINITIONS:

"Debt" means any assessment, premium, penalty, fine, tax or other amount of money owed to the state or any of its political subdivisions because of a judgment, fine, permit violation, license assessment, defaulted workers' compensation premium, penalty or other assessment presently delinquent or due and required to be paid to the state or any of its political subdivisions, including any interest or additional penalties accrued thereon.

"Debtor" means any individual, corporation, partnership, association, limited liability company or any other form or business association owing a debt to the state or any of its political subdivisions. "Political subdivision" means any county commission; municipality; county board of education; any instrumentality established by a county or municipality; any separate corporation or instrumentality established by one or more counties or municipalities, as permitted by law; or any public body charged by law with the performance of a government function or whose jurisdiction is coextensive with one or more counties or municipalities. "Related party" means a party, whether an individual, corporation, partnership, association, limited liability company or any other form or business association or other entity whatsoever, related to any vendor by blood, marriage, ownership or contract through which the party has a relationship of ownership or other interest with the vendor so that the party will actually or by effect receive or control a portion of the benefit, profit or other consideration from performance of a vendor contract with the party receiving an amount that meets or exceeds five percent of the total contract amount.

EXCEPTION: The prohibition of this section does not apply where a vendor has contested any tax administered pursuant to chapter eleven of this code, workers' compensation premium, permit fee or environmental fee or assessment and the matter has not become final or where the vendor has entered into a payment plan or agreement and the vendor is not in default of any of the provisions of such plan or agreement.

LICENSING: Vendors must be licensed and in good standing in accordance with any and all state and local laws and requirements by any state or local agency of West Virginia, including, but not limited to, the West Virginia Secretary of State's Office, the West Virginia Tax Department, West Virginia Insurance Commission, or any other state agencies or political subdivision. Furthermore, the vendor must provide all necessary releases to obtain information to enable the Director or spending unit to verify that the vendor is licensed and in good standing with the above entities.

CONFIDENTIALITY: The vendor agrees that he or she will not disclose to anyone, directly or indirectly, any such personally identifiable information or other confidential information gained from the agency, unless the individual who is the subject of the information consents to the disclosure in writing or the disclosure is made pursuant to the agency's policies, procedures and rules. Vendors should visit www.state.wv.us/admin/purchase/privacy for the Notice of Agency Confidentiality Policies.

Under penalty of law for false swearing (West Virginia Code, §61-5-3), it is hereby certified that the vendor acknowledges the information in this said affidavit and are in compliance with the requirements as stated.

Vendor's Name: SHARP ELECTRONICS CORPORATION

Authorized Signature: [Signature] Date: JUNE 2, 2008

SHARP®

UNITING PRODUCTION AND THE WORKGROUP

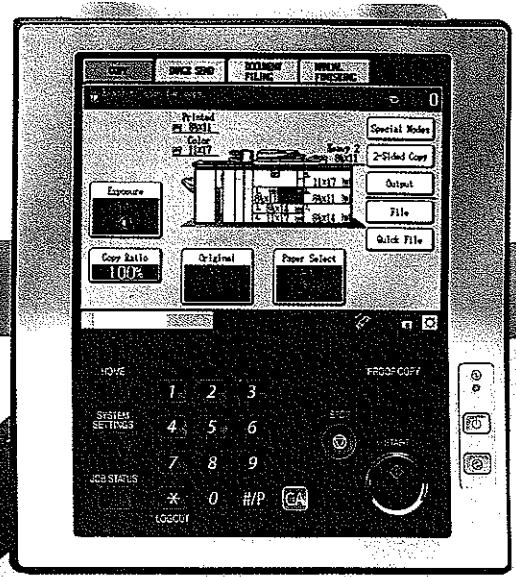

MX-M850
MX-M950
MX-M1100



8/6/11
D

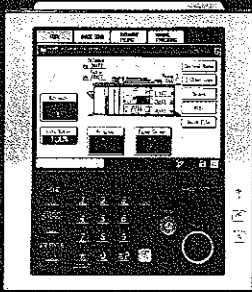

LCD Operation Panel

Large, 10.4-inch color touch-screen LCD display is the MX-M850/M950/M1100 dashboard, providing users with intuitive menus for every machine function, from copy and scanning input to final finishing as well as comprehensive diagnostics for easier maintenance.

HIGHER RELIABILITY, HIGHER PRODUCTIVITY

Today, the business world has a new standard for high speed document handling and output in production environments with the introduction of the Sharp MX-M850/MX-M950/MX-M1100 monochrome document systems. From walk-up office environments and corporate data centers to high-volume CRD and service bureaus, these top-of-the-line Sharp document systems will provide new capabilities for the end-user as well as opportunities for business growth. With flexible and versatile options from paper feed to finishing, as well as highly customizable software architecture, the Sharp MX-M850, MX-M950 and

DURABILITY, RELIABILITY

MX-M1100 adhere to the principles that have made Sharp document systems the award-winning choice. **COUNT ON SHARP'S AWARD-WINNING HISTORY** If our history offers insight into the future, then you can rest assured that when you invest in one of the new Sharp MX-M850, MX-M950 and MX-M1100 document systems, you will be choosing the proven Sharp heritage of document imaging. Independent industry authorities including Buyer's Laboratory, Inc., Better Buys for Business, Inc., and BERTL have consistently recognized the superlative achievements that set Sharp ahead of the competition. Awards include Product Line of the Year, Best Security Solutions, Innovation Awards, IT Friendliness and Editors' Choice. We earned them in the past. Expect them in the future!

DESIGNED TO CONQUER NEW MARKETS

What Every Business Needs

Sharp product professionals and engineers not only recognized the need for fundamental product characteristics, such as durability and reliability, they also understood where these devices would be positioned in the marketplace. This vision resulted in the MX-M850/M950/M1100's ability to be an excellent choice in government and education environments, where cost and productivity are crucial. Additionally, these devices are an excellent fit in markets such as legal, financial and medical, where data security and confidentiality are mandatory.

Industry experts have acknowledged that Sharp knows how to build a great MFP. And with the demand for a Sharp entry in the production segment, our market planning, research and development teams called for more than an upgrade to our current product line. It meant new thinking from start to finish in order to bring Sharp performance to new markets. This "clean sheet" approach to engineering the MX-M850, MX-M950 and MX-M1100 MFPs means every customer in the marketplace can enjoy the same level of satisfaction that current Sharp MFP owners have come to appreciate. Sharp's new flagship models will help redefine our position in the production market space. With three engine speeds (85ppm/95ppm/110ppm), standard networking and flexible configurations to target specific business needs, it's time to think **Sharp** for production environments.

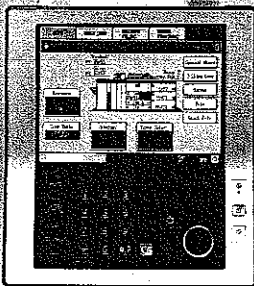
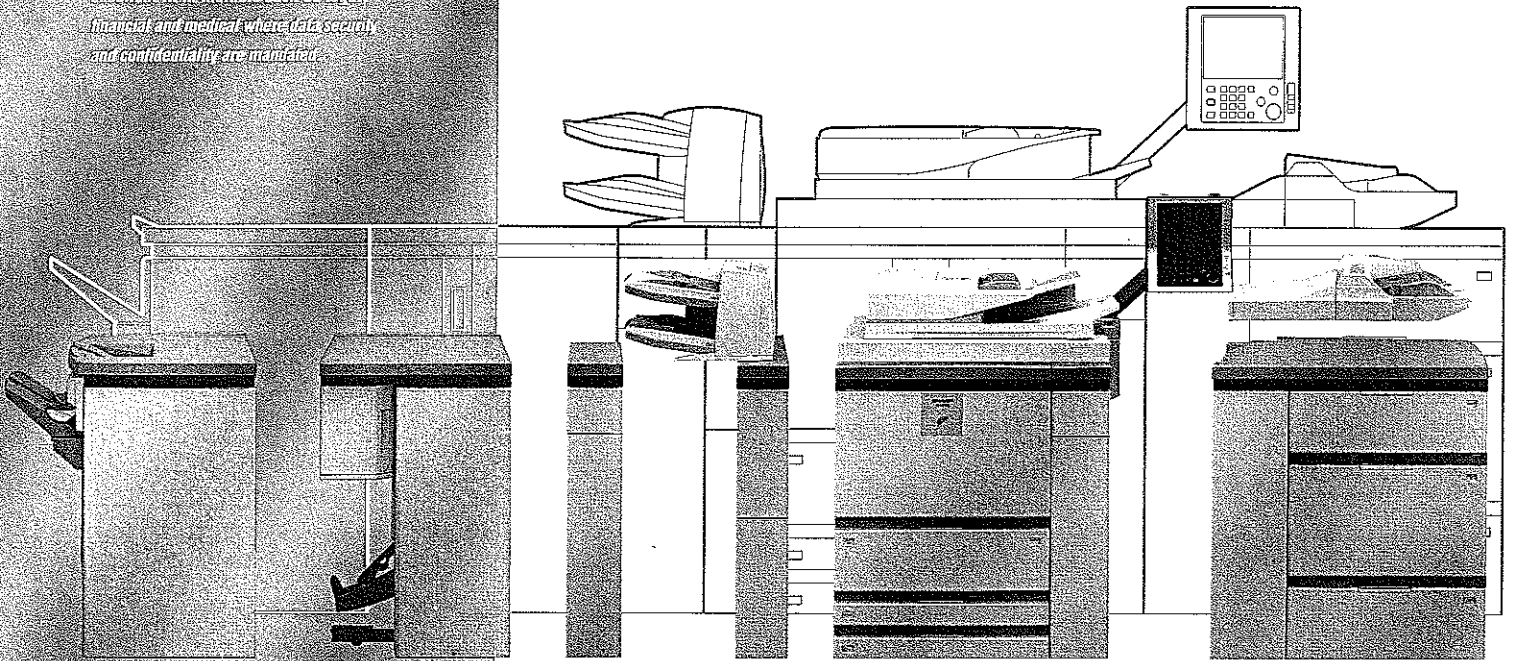

Job Status Lamp

High-visibility red and green job status lamps allow operators to monitor a print or copy job from start to finish, even from across the room.

- The Sharp MX-M850/MX-M950/MX-M1100 document systems have been engineered and built from the ground up to handle the rigid demands of production environments, easily producing hundreds of thousands of pages per month.
- Durability, reliability, and productivity were key components in Sharp's engineering philosophy and design specifications when developing these high-volume workhorses. With new standards, new markets, and new benchmarks, these high-speed monochrome document systems fit perfectly into CRD, corporate office and print-for-pay as well as the most challenging print-on-demand environments.
- Each MX-M850/M950/M1100 document system can be customized with a variety of options to create a unique solution for every challenging production setting. Whether you choose the 85ppm solution for walk-up or corporate environments, the mid-range 95ppm alternative or the powerful 110ppm system, you can be assured that Sharp can configure a system that's right for any environment.

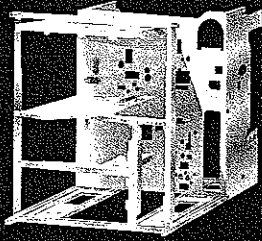

Highly-Rigid Main Frame

A newly developed, highly-rigid frame helps better protect and isolate critical machine components. This also ensures increased reliability and durability in order to withstand heavy use from high-speed and high-volume output.

HIGH PERFORMANCE

From conception to execution, the goal in any production environment is performance.

And that's why Sharp engineered breakthrough performance features into the MX-M850/

M950/M1100. These are precision design characteristics you can't see, but will certainly

appreciate in daily use. **SUPERIOR PAPER SUPPORT** Among the best in class by virtually

all measures including an 8-way paper supply and paper capacity up to 8,050 sheets.

HIGH-VISIBILITY CONTROL PANEL 10.4-inch color LCD touch-screen display with monitor

status light easily visible from across the room helps the operator navigate any job intuitively.

PRECISION

FAST PRINT PERFORMANCE Outputs data-intensive documents, presentations,

or image files in as little as 7 seconds.* **ADVANCED SCANNING CAPABILITY**

Sharp's 250 sheet duplex single-pass-feeder with Scan² technology can scan two-sided

documents in a single pass, maximizing productivity while minimizing paper handling.

STANDARD NETWORK INTERFACE These powerful machines are fully network

ready and offer web-based device management for easy configuration and set-up.

EASY SERVICEABILITY Long life drum (OPC) with up to 1 million impressions; slide-out

components save space when maintenance is needed; 500,000 impression PM cycle;

continuous running through toner replenishment process.

Developer Cooling Systems

The MX-M850/M950/M1100 in-heat air cooling system for the developer unit helps prevent excessive heat build-up to keep image quality stable even in high-volume environments.

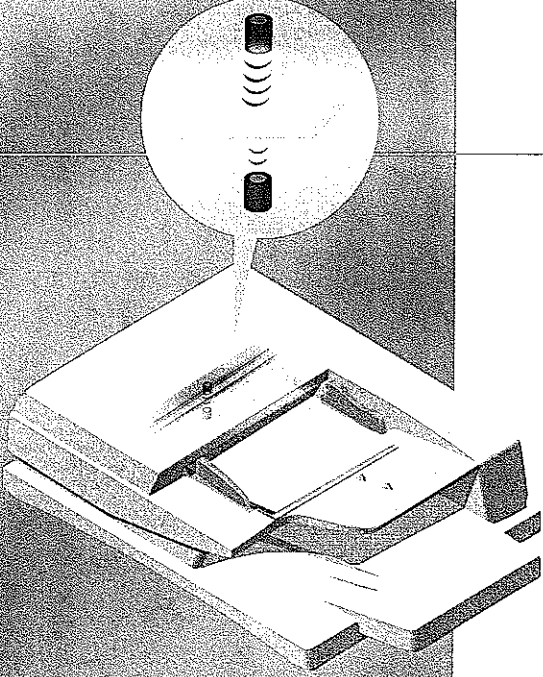
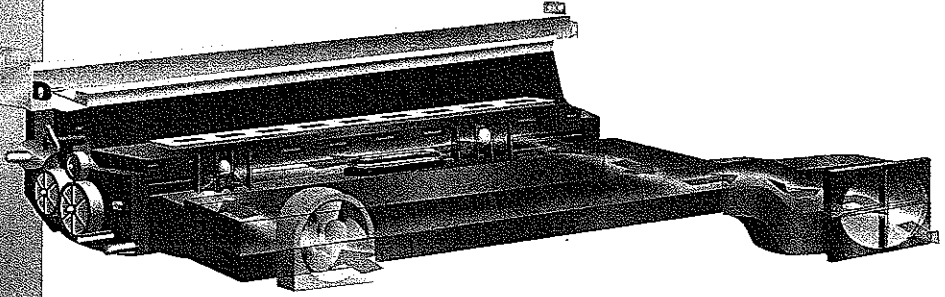

Multi-Feed Detection Sensor (MX-M950, MX-M1100)

The precision engineering design of the Sharp multi-feed detection system employs ultrasonic technology to help diagnose and detect misfeeds from the document feeder as well as the paper feed section from the paper trays.

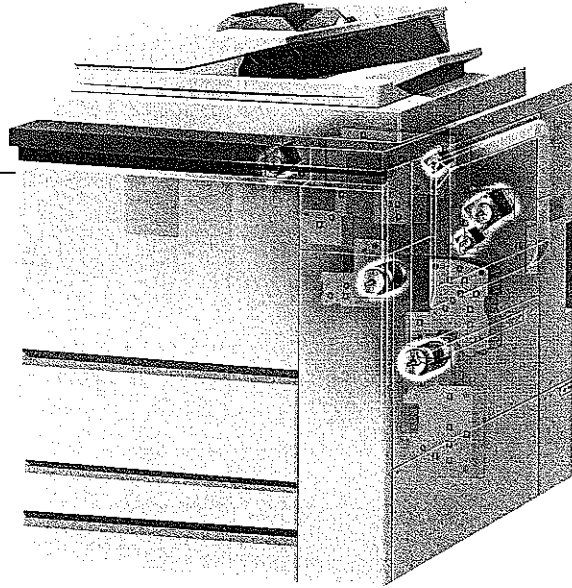

Independently-Driven Unit

Independent motor units are employed for essential sections of the MX-M850/M950/M1100 such as the paper pick-up unit, the paper transfer unit, etc. This design improvement provides highly reliable operation and helps to ensure dependable paper transportation throughout each reprographic cycle, increasing durability for the long run.

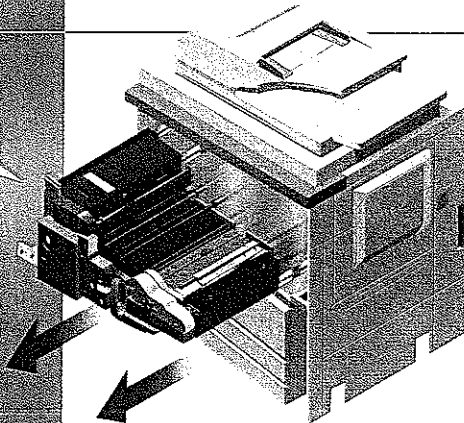
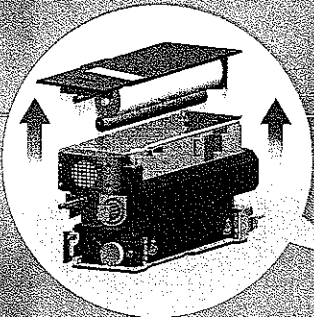

Slide-out Components for Easy Maintenance

This design makes service and general maintenance of the MX-M850/M950/M1100 easier by allowing technicians to slide out main units without the need to disassemble the entire machine to adjust or exchange sub-components.

FLEXIBILITY AND VERSATILITY

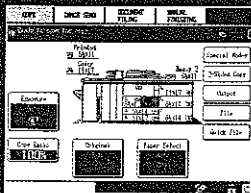

Intuitive User Interface

Every operator, from the casual walk-up user to the mail room production staff, will find it easier to get the job done from start to finish with the easy-to-understand and easy-to-use graphic user interface on the touch-screen LCD panel.

The key to implementation of any production document system in the workplace

is the flexibility to configure the machine for the variety of applications

it needs to perform and its versatility to please a wide base of users as well as

business applications. Sharp's MX-M850/M950/M1100 document systems excel in their

ability to customize hardware and software configurations from paper input to

document management and finished output. Businesses can easily add powerful

network printing that offers point-and-click simplicity.

BREAKTHROUGH

FEATURES THAT KEEP YOUR BUSINESS MOVING

The MX-M850/M950/M1100 also come standard with 1.28 GB of standard memory,

enabling them to be the hub of productivity even in busy workgroups. An 80 GB HDD

ensures robust processing power for large complex jobs. ● Copying and printing on

up to 170 lb. index to produce a variety of documents in-house ● Security-enabled

NIC Interface to restrict user access with IP/Mac Address Filtering, plus port control

and protocol management ● Versatile application integration with Sharp OSA™

technology enables users to access network applications right from the LCD Panel

● My Sharp™ provides comprehensive 24-hour online end-user training.

Rich Interactive Graphics

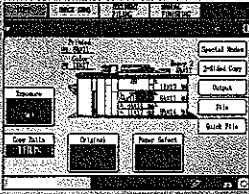

Copy Mode displays machine status including paper sizes available on the intuitive touch-screen LCD display monitor.

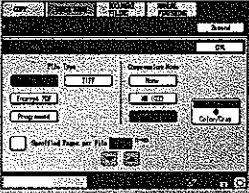

ImageSEND includes simple settings for file type and file compression to maximize efficiency in a networked enterprise environment.

A FLEXIBLE DESIGN TO MEET THE DEMANDS OF YOUR UNIQUE ENVIRONMENT

Designed for high-volume production environments, the new MX-M850/M950/M1100 series document systems deliver **lightning-fast output** with robust **multi-tasking performance**, so your workflow never misses a beat. With a standard paper capacity of 3,000 sheets—expandable to 8,050 sheets, the MX-M850/M950/M1100 series document systems can manage large scale jobs with incredible efficiency. Plus, a **flexible paper handling** system combined with a wide range of supported media allows these powerful performers to meet the needs of any high-volume production environment. For large volume copy jobs or print jobs, choose from either the 4,550-sheet letter-size triple paper tray or the 4,000-sheet ledger-size triple paper tray—which supports paper weights up to **170 lb. index!** For even more flexibility add the optional 500-sheet auto-bypass tray.

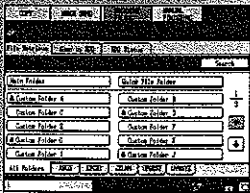

Document Filing makes it easy to find and retrieve forms and templates or receive and save new documents.

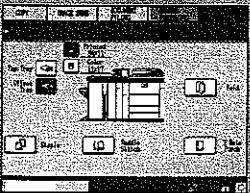

Manual Finishing On-line Mode enables you to finish the job—including inserting sheets, stapling and even Z-folding—while the machine is not printing.

1. **4,000-sheet 3-Drawer Ledger-Size Large Capacity Tray** provides greater paper capacity for uninterrupted runs of high-volume jobs, even up to 12" x 18".
2. **Operation Panel** features highly-visible and graphically intuitive 10.4" color LCD touch-screen covering all operations from input to finishing, as well as machine diagnostics.
3. **Standard Duplexing Single Pass Feeder** with Scan² technology; multi-bypass tray has a large 250 original sheet capacity.
4. **Main Unit** can be configured with a variety of input and output hardware options, as well as software options that include network color scanning, network printing, Super G3 faxing and more.
5. **Inserters** enable you to insert pre-printed covers and inserts to your documents, for truly professional results.
6. **Z-Folding Unit** automatically folds pages to accommodate professional document distribution.
7. **Saddle Unit** delivers a wide range of finishing capabilities including center folding and stapling.
8. **Finisher** provides robust stapling capabilities for any application up to 100 sheets.

SHARP®

Multiple paper feed
detection (MX-M950/M1100)

MX-M850

A STEP UP IN WALK-UP PERFORMANCE

At 85 copies per minute plus customized versatility from copy and print input to document finishing, the Sharp MX-M850 represents a new benchmark in walk-up production performance. And if you need more, step up to the 95ppm MX-M950!

First copy time
4.0 seconds (MX-M850)
3.2 seconds (MX-M950/M1100)

Online toner replenishment

Change-on-the-fly toner (replacement of toner cartridge while engine is running)
120,000 average page yield + 15,000 in 2nd hopper

Multiple finishing options

Booklet making, 3-hole punch and GBC® SmartPunch™, Z-folding, post sheet insertion

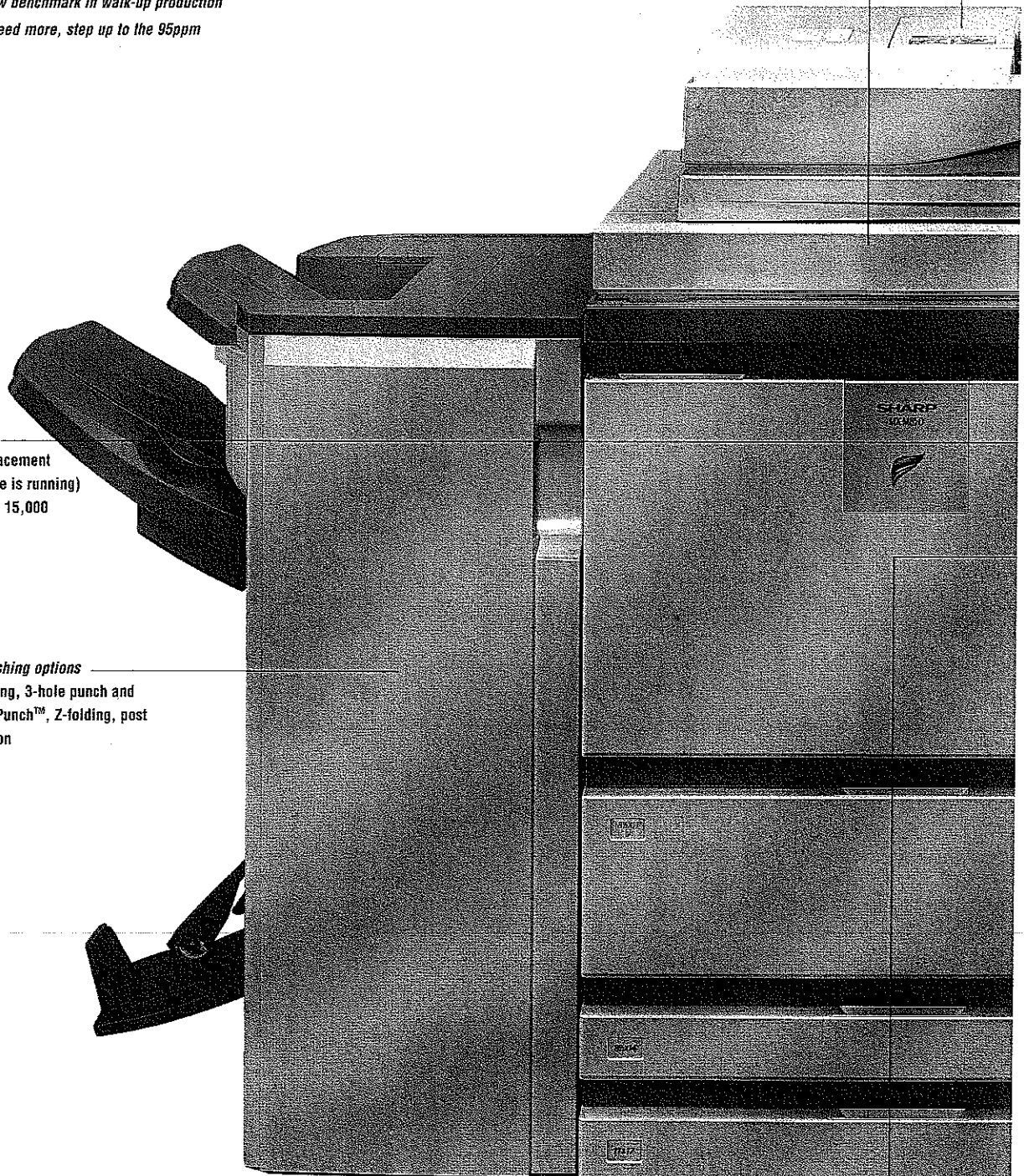

Developer unit cooling system

Arm structure for accessibility,
ease-of-use and visibility

Job status lamp for visible diagnosis

10.4" color touch-screen display

Duplex single pass feeder with Scan²
capacity 250 sheets

Long-life drum—up to 1 million impressions
PM cycle: 500,000 impressions

Maximum available paper capacity
8,050 sheets

Network-ready for easy configuration and management

Highly-rigid frame for durability

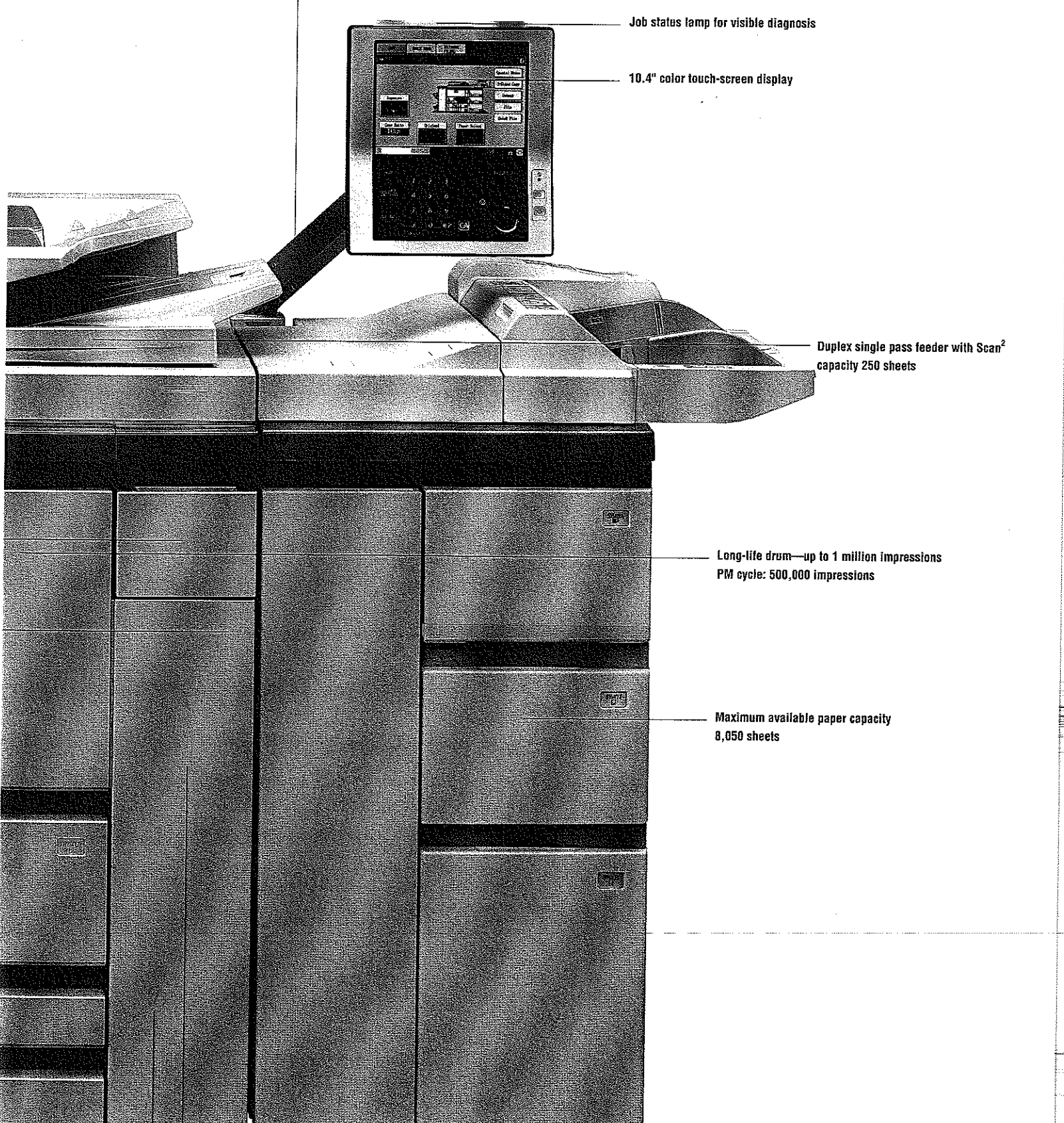

**MAXIMIZE EFFICIENCY AND PRODUCTIVITY
EXPANDED CAPABILITIES FROM START TO FINISH**

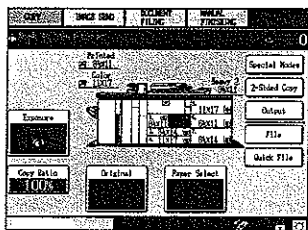

The large, 10.4" Color LCD touch-screen display is intuitive and easy-to-use.

Easy-to-use touch screen display

The MX-M850/M950/M1100 document systems utilize a 10.4" touch-screen color display, which offers large **easy-to-read** text and icon-driven graphics, as well as large easy-to-see menus that are intuitive and easy to navigate. This unique display features a **Customizable User Interface** that allows the touch-screen to display "short-cut" keys that can be programmed to provide instant access to the features your business uses most often.

High-efficiency scanning

For optimum productivity, the new MX-M850/M950/M1100 document systems offer Sharp's award-winning **Scan² technology**. This innovative technology utilizes dual scan heads to simultaneously scan both sides of a document in a single pass, minimizing paper misfeeds and improving reliability. Additionally, with Sharp's newly designed **250-sheet duplex single pass document feeder**, documents are scanned at up to 120 images-per-minute on the MX-M1100, so even large projects are completed quickly. For even more versatility, add the optional Color Expansion Kit.*



FEATURE INNOVATION

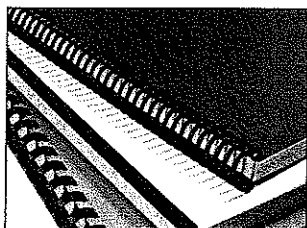

Add Style and Versatility to Bound Documents with the GBC SmartPunch™

*Providing professionally bound finished documents to your customer is now easier than ever with the GBC SmartPunch in-line punching system.** With up to six common punching styles, the GBC SmartPunch can produce ready-to-bind documents at up to 110 pages-per-minute when connected to an MX-M1100 document system. Now you can combine punching, printing and collating into a single operation, virtually eliminating downtime from off-line manual punching. Interchangeable die sets make changeovers easy without the need for tools.*

Professional finishing

The MX-M850/M950/M1100 document systems offer several modular finishing options to automate your output as well as give your documents a professional appearance. The optional **100-Sheet Stapler Finisher** speeds through large projects, giving you complete control over deadlines. The **15-Sheet Saddle Unit** can center staple documents to create professional looking booklets on letter, legal, ledger or 12" x 18" size paper. For even more versatility, the MX-M850/M950/M1100 offer modular options for **Z-Folding, Inserting and Hole-Punching**.

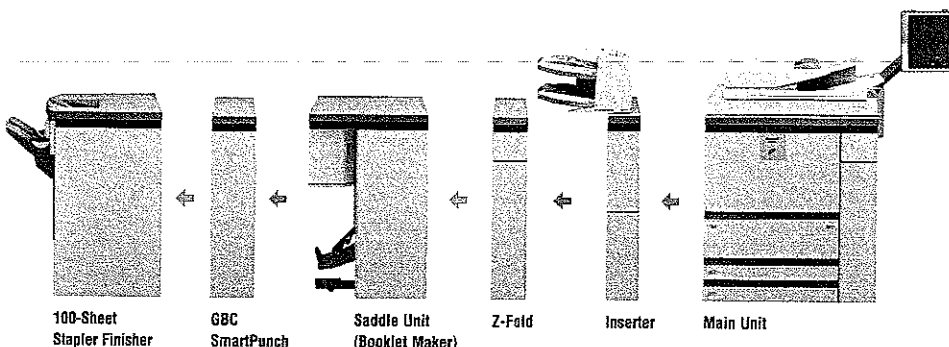

*Some features require optional equipment.
**Spines sold separately.

DOCUMENT WORKFLOW & DISTRIBUTION

STREAMLINE YOUR WORKFLOW WITH ADVANCED DISTRIBUTION FEATURES

Integrated Network Scanning

With Sharp's powerful ImageSend technology, you get one-touch distribution features that centralize document workflow, help reduce mail costs and save time. With up to seven destinations—E-mail, Desktop, FTP, Network Folder (SMB), USB, Fax and Internet Fax—getting your document where it needs to go is as easy as pushing a button. Send to Group mode allows mixed group broadcasting to E-mail, Fax and Internet Fax for increased efficiency.

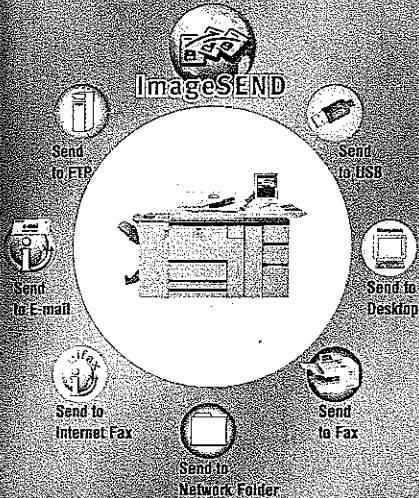

Scan Documents in Full Color

With the optional COLOR EXPANSION KIT, users can scan documents for E-mail, Network Folders and other select destinations in FULL COLOR. This innovative feature allows your business to easily share hard-to-get color documents, such as brochures, newsletters, quarterly reports, invoices and more.

Increase Efficiency with Document Filing

For even more efficiency, the MX-M850/M950/M1100 document systems offer convenient Document Filing. With this on-board storage/retrieval system users can store frequently used files, such as copy jobs, print jobs, forms and more. Plus, with the Color Expansion Kit, documents can be scanned and saved in full color. The Document Filing System comes standard with 40 GB of document storage capacity, so everyone can easily store, retrieve and route saved documents.

True multi-tasking with dual processing

The new MX-M850/M950/M1100 document systems feature a 64 bit, multi-tasking controller that delivers copy, fax and print jobs continuously for optimum efficiency. Other controllers only perform one operation at a time. But the MX-M850/M950/M1100 continually processes incoming jobs even while existing jobs are output. The result? A workflow that never slows down—even at crunch time.

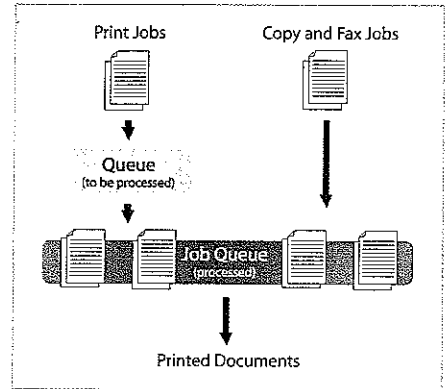

Convenient USB support

The MX-M850/M950/M1100 also support popular USB memory devices for today's on-the-go professionals. Scan files directly to a USB device, or simply plug in and print directly without creating network traffic. Most popular industry-standard file formats are supported, including TIFF, JPEG, PDF, and Encrypted PDF.*

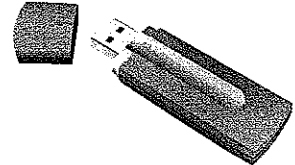

Security at your fingertips

Get the control and security you need to minimize risk in today's changing office environment. The MX-M850/M950/M1100 support LDAP with integrated User Authentication. Workgroups can set up rights to features and functions, providing unprecedented control over usage and costs. With controls for up to three levels of identification, you can protect sensitive documents from being scanned, faxed or e-mailed—so your data is never compromised.

Convenient and secure e-mail distribution

With LDAP, there's no need to manually enter a recipient's complete e-mail address. Simply enter the first few characters and the MX-M850/M950/M1100 automatically searches and displays a list of matching names. And with the Unique File Naming feature, you can enter specific file names with custom subject fields, so it's easier to recall files when you need them.

Powerful Super G3 faxing

The optional Super G3 Fax Kit delivers lightning-fast faxing for busy workgroups. Integrated PC Faxing allows you to fax a document directly from your desktop. With the Finisher installed, you can collate, staple and/or copy inbound faxes, so they're ready to distribute, saving time. Inbound Fax Routing allows you to set parameters so that faxes can be sent directly to your e-mail address, giving mobile users the ability to check on incoming orders, purchase orders, and more. Settings can be easily managed through the user-friendly web page. For additional savings, the optional Internet Fax Expansion Kit can help reduce long-distance phone costs.

SUPER
GB

*Some features require optional equipment.

IMAGINE THE POSSIBILITIES GET MORE OUT OF YOUR BUSINESS APPLICATIONS



Sharp OSA technology at a glance

- Automate tasks and save time with seamless integration between the MX-M850/M950/M1100 and network applications
- Centralized applications minimize set-up and installation on multiple Sharp products
- Virtually eliminates repetitive tasks and streamlines workflow, increasing efficiency
- Maximize your return on investment with tighter integration among IT assets
- Industry standard programming leads to faster deployment of new solutions

The MX-M850/M950/M1100 document systems provide powerful functionality for your business so you can immediately leverage your previous investments in data management infrastructure. While others are limited to a small circle of productivity, Sharp's newest innovation, the Sharp OSA™ development platform, allows users to leverage the power of their back-end systems right from the control panel. It's really a new way of thinking with "power at the panel" for automation of tasks and a streamlined workflow.*

You'll save time and increase the efficiency of everyday tasks with Sharp OSA technology because it can be virtually seamless to the user. Any MX-M850/M950/M1100 anywhere in the organization can display choices that were once only available on a desktop PC. With one-touch access to business applications via Sharp OSA integration, you can start and finish a document distribution task without worry.

The Sharp OSA development platform is the logical choice as a complement to your existing infrastructure because the MX-M850/M950/M1100 becomes the gateway to providing fast,

SCALABILITY

VERSATILE

flexible access to documents and applications...no matter where you are in the office. You also get the controlled access and tracking capability you require with tighter integration capabilities for network security and accounting applications. With such comprehensive control, you'll be able to manage your document workflow easily, efficiently, and more securely.

Sharp OSA technology also provides customization. With the ability to personalize applications and processes specific to your business, Sharp OSA technology can help eliminate redundancy and streamline workflow, helping to save time and optimize productivity. And since Sharp OSA technology utilizes industry-standard network protocols such as SOAP, XML, and XHTML, third-party software developers can deliver customized solutions to your business faster than ever.

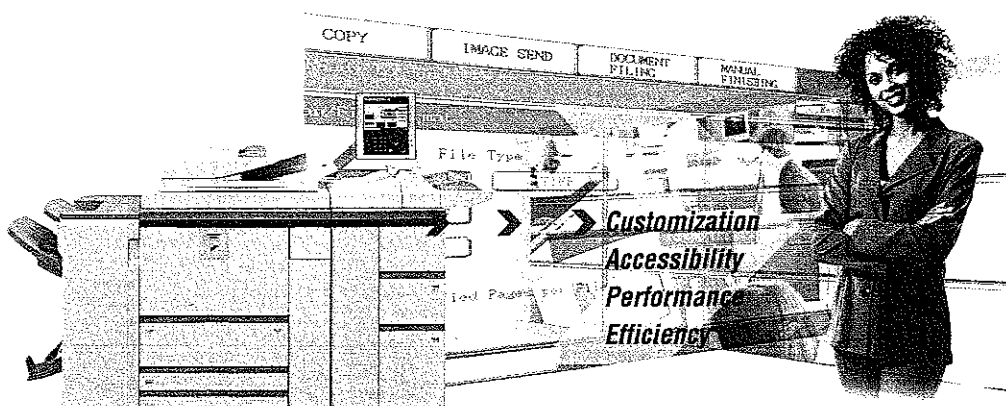

A Leader in Security

To help protect your data, the MX-M850/M950/M1100 offers several layers of security, making Sharp the optimal choice to help protect employee privacy and intellectual property. As a leader in office equipment security, Sharp makes it easy for any business or government entity to safely deploy digital copying, printing, scanning and faxing.



Outstanding MFP Security Solution



Most Secure MFP Award



SHARP

The Sharp 24/7 Training Advantage

To make managing your new MX-M850/M950/M1100 document systems simple and easy, ask your local Authorized Sharp Dealer about My Sharp, a dedicated customer care website that offers solutions, resources and information specific to your new Sharp product.

SAFEGUARD YOUR COMMUNICATIONS ADVANCED DOCUMENT SECURITY PROTECTS YOUR ASSETS

Account codes

Account management enables administrators to control access functions (Copy, Scan, Fax, and Print) and to monitor usage.

Helps keep your documents confidential

To help protect your printed documents from unauthorized viewing, the MX-M850/M950/M1100 supports IPPS protocol and offers confidential printing that requires users to enter a PIN code in order to print a queued document—making it easier to comply with healthcare regulations like HIPAA.

Network scanning access

To protect your network from unauthorized e-mail communications, the MX-M850/M950/M1100 authentication supports SMTPS, FTPS and user authentication, requiring users to login before performing any network scanning operations.*



Control device access over the network*

To help restrict access to the device over the network, the MX-M850/M950/M1100 offers:

- Secure Socket Layer (SSL Encryption)
- IPv6 and IPsec
- IP/MAC address filtering, protocol enable/disable and port management for maximum security.

Data erase and encryption*

To help protect your data, the MX-M850/M950/M1100 offers an optional Data Security Kit that encrypts document data in compliance with using the Advanced Encryption Standard (AES). Additionally, the Data Security Kit erases the temporary memory on the hard drive by overwriting the encrypted data up to seven times, providing an unprecedented level of assurance.

Tracking and auditing information

Legislation and industry policies require companies to be more aware of information flow. Sharp offers both built-in and additional hardware/software which allows users to control, access and track usage of each device on the network.

These scalable security offerings aim to protect your intellectual property, preserve confidential information and help your business to meet regulatory requirements, such as the Health Insurance Portability and Accountability Act (HIPAA), and the Gramm Leach Bliley Act (GLB). For additional information visit: www.sharppusa.com/security

*Data Security Kit, IPv6, IPsec, SMTPS, SSL and FTPS support available Summer 2007.

INTEGRATED, USER-FRIENDLY SOFTWARE MANAGE DOCUMENT WORKFLOW

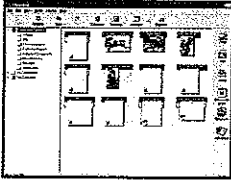

Sharpdesk desktop document management software helps users organize, annotate, edit and combine files prior to distribution.

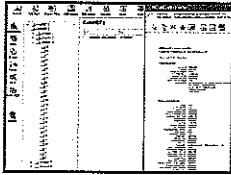

Doc2NET

Sharp's alliances with leading developers make it easy to implement enterprise-level solutions for document archiving, forms generation and more.

Managing the digital workflow has never been easier—and more seamless

Powerful, flexible and intuitive, Sharpdesk™ software enables you to easily integrate scanned documents into your everyday workflow. Easy-to-use tools help you organize, edit, even combine scanned files, for maximum productivity. The Search and Index feature provides sophisticated tools that enable you to retrieve archived Sharpdesk documents with incredible ease.

Automated forms management and distribution

Sharp's MX-M850/M950/M1100 integrate fluently with Reform Enterprise by FabSoft™. With the ability to automatically route documents to a fax or e-mail address, MFP, printer, or FTP site, Reform speeds up your workflow and saves valuable time. Plus you can customize forms, invoices, and other transactional documents, enabling you to automate processing while maintaining a professional image.

Advanced document filing and archiving

Sharp's MX-M850/M950/M1100 document systems are compatible with Liberty's Doc2NET™, enabling you to capture, organize, retrieve, and secure documents. With structured indexing, full text search

DOCUMENT MANAGEMENT

capabilities, and output and distribution capabilities via fax, e-mail, and print, Doc2NET delivers quick and convenient access to shared documents for the entire workgroup. Scan images can be sent directly from the MFP to the Doc2NET cabinet using the MX-AMX1 option.

Easy integration with document imaging

eCopy® ShareScan™ allows the MX Monochrome Series' scanning function to integrate with a multitude of Enterprise Content Management packages you may already be using.

The Sharp Administration Utility Suite

To help you manage the MX-M850/M950/M1100 and the host of versatile features, Sharp designed the Administration Utility Suite, a collection of easy-to-use software that can simplify the installation, monitoring, and use of the MX-M850/M950/M1100 document systems.

Equitrac Office

Additionally, Sharp offers Equitrac Office® and Equitrac Express®, options with extensive reporting and security controls.

Standard Print/Copy/Scan Tracking

The MX-M850/M950/M1100's versatile functionality will make it the most widely-used printer in the workgroup. To monitor and track all of this activity, Sharp includes standard copy/print accounting controls. The Print/Copy/Scan auditor enables administrators and IT Managers to track usage by ID number (up to 1000 accounts) as well as by PIN code authorization.

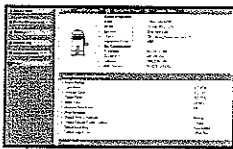

Printer Administration Utility

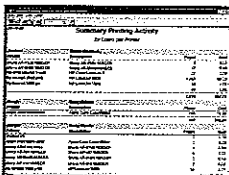
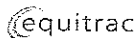

Track print usage for accounting purposes with Equitrac's easy-to-use software, which provides extensive reporting and security features.

MX-M850 MX-M950 MX-M1100 SPECIFICATIONS

Main Specifications

Base Model	High speed monochrome digital document system console with 64 bit multi-tasking controller; includes 80 GB hard drive with document filing, 250-sheet Duplexing Single Pass Feeder and 3000 sheet paper capacity.		
Functions	Copy, print, network print, network scan, and fax ¹		
Copy System	Dry electrostatic transfer system with organic photo conductor, magnetic brush dual-component developing system and heat roller fusing		
Original Size (Max)	11" x 17" (sheets or bound documents)		
Copy Size	Min. 5 1/2" x 8 1/2", Max. 12" x 18"		
Copy Speed (pages per minute)	Paper size	MX-M850	MX-M950 MX-M1100
	8 1/2" x 11"	85	95 110
	8 1/2" x 11R"	64	70 79
	8 1/2" x 14"	54	59 68
	11" x 17"	47	51 59
	12" x 18"	42	48 57
First Copy Out Time	MX-M850: 4.0 seconds or less; MX-M950/M1100: 3.2 seconds or less (Based on letter size original scanned from the glass with polygon motor running)		
Warm Up Time	240 seconds or less		
Copy Settings	Variable Zoom: 25% to 400% (with DSPF 25%-200%); 9999 continuous copy		
Fixed Magnification	25%, 50%, 64%, 77%, 100%, 121%, 129%, 200, 400%		
Original Feed System	250-sheet Duplex Single Pass Feeder (DSPF) with mixed size original detection Original Sizes: 5 1/2" x 8 1/2", 8 1/2" x 11", 8 1/2" x 11" R, 8 1/2" x 14", 11" x 17" Original weight: 11 to 54 lb. bond (17 lb. vellum to 110 lb. index). Capacity based on 21 lb. bond, letter size		
DSPF Scan Speed (Letter Size)	MX-M850: 85 images per minute MX-M950/M1100: 120 images per minute		
Paper Feed System	Standard: 3000-sheet large capacity tray with (3) drawers. Includes 2000 sheet letter size tandem tray (drawer 1), 500-sheet multi-purpose tray (drawer 2) and 500-sheet multi-purpose tray (drawer 3). Optional: 4550-sheet letter/statement size tray with (3) drawers, 4000-sheet ledger size multi-purpose tray with (3) drawers, 3500-sheet letter size large capacity tray, 3000-sheet ledger size multipurpose large capacity tray, 500-sheet bypass tray or 100-sheet bypass tray (some options not available with all configurations).		
Paper Sizes	5 1/2" x 8 1/2", 7 1/4" x 10 1/2", 8 1/2" x 11", 8 1/2" x 11" R, 8 1/2" x 13", 8 1/2" x 14", 9" x 12", 11" x 17", 12" x 18"		
Paper Types	Standard paper trays: 16 lb. bond to 110 lb. index, includes plain paper, heavy paper, recycled, pre-printed, pre-punched colored, and letterhead. Optional paper trays: 16 lb. bond to 170 lb. index, supports same as standard trays; also supports thin paper, transparency, tab and label paper through bypass tray.		
Duplexing	Automatic trayless; supports 16 lb. bond to 110 lb. index; paper types include plain paper, heavy paper, recycled, pre-printed, pre-punched colored, and letterhead.		
CPU	MX-M850: 868 MHz RISC processor MX-M950/M1100: 992 MHz RISC processor		
Standard Memory	1.28 GB memory (shared)		
Hard Disk Drive	80 GB; 40 GB partition for document filing/40 GB partition for copy/print/scan operations		
Copy Resolution	Scan: 600 x 600 DPI (Max.), output: 600 x 600 dpi		
Exposure Modes	Text mode, text/printed photo mode, printed photo mode, text/photo mode, photo mode; map mode, light original mode, auto exposure control or 9 step manual.		
Copy Features	Scan-Once Print-Many, electronic sorting, Auto Paper Selection (APS), Auto Magnification Selection (AMS), auto tray switching, rotation copy, job reservation, tandem copy, margin shift, job build, edge erase, center erase, dual page copy, cover pages, insert pages, tab paper insert, transparency insert, card shot, multi-shot, reverse image, mirror image, cover page, multi-page enlargement, proof copy, photo repeat, document filing, user account control, job programs, date print, page print and text print.		
Account Control	1000 user accounts		
Job Build	Up to 10,000 sheets		
Output Tray	Standard output tray capacity: 250 sheets		
Display	10.4" touch-screen LCD with 256 colors and fluorescent tube back light		
Interface	USB-2.0 (full speed): 1 port, USB-2.0 (high speed): 1 port 100BaseT/10BaseT Ethernet with RJ-45 connection: 1 port		

(Main Specifications continued)

Network Operating	Windows [®] 98, Windows Me, Windows XP, Windows XP x64, Windows NT [®] (SP5 or later), Windows 2000, Windows Server [®] 2003, Windows Server 2003 x64, Windows Vista [™] , Windows Vista x64, Unix [®] , Novell [®] NetWare [®] 3.x/4.x/5.x, MAC OS [®] 9.x, MAC OS X
Network Protocols	TCP/IP, IPv6, IPsec, SSL, SMTP, FTP, SMB, IPX/SPX, and AppleTalk [®] for Macintosh [®] environments. ³
Firmware	Flash ROM with USB and network update capability
Device Management	Web based device setup, management and authority control; Administrator level and User level login access
Power Requirement	208-240 VAC, 60 HZ, 16 Amps
Power Consumption	MX-M850: Max 2.4 KW or less, pre-heat 160 W or less, sleep mode 20 W or less; MX-M950: Max 3.5 KW or less, pre-heat 178 W or less, sleep mode 20 W or less; MX-M1100: Max 3.5 KW or less, pre-heat 205 W or less, sleep mode 20 W or less
Weight	Approx. 662 lbs. (main unit) ²
Dimensions	64 7/8" (w) x 30 1/8" (d) x 58 1/3" (h) ²

Printing System Expansion Kit (option)

Emulation	PCL6 (XL), PCL5e, optional PS3
Resolution	1200 x 1200 DPI, 600 x 600 DPI
Print Speed	MX-M850: 85 PPM, MX-M950: 95 PPM, MX-M1100: 110 PPM (8 1/2" x 11")
Print Drivers	Windows 98, Windows Me, Windows NT4.0 (SP5 or later), Windows 2000, Windows XP, Windows XP x64, Windows Server 2003, Windows Server 2003 x64, Windows Vista and Windows Vista x64, MAC [®] PPD (optional), MAC OS 9, MAC OS X
Features	Duplex Print, Pamphlet Print, Binding Edge, N-up print, Fit-to-Page, Margin Shift, Poster Print, Rotate Print, Zoom, Mirror Image, Overlay, Different Paper Insert, Transparency Insert, Tab Print, Chapter Inserts Print, Paper Fold Print, Reverse Order, Tandem, Watermarks, PIN Print, Print Hold, Proof Print, Print Audit, Graphics Mode Selection, Continuous Print, and Font/Form Downloads (Some features not available on all print drivers). ¹
Direct Printing	PDF/Encrypted PDF/TIFF/JPEG print, E-mail print, FTP Pull Print, USB Pull print, Web-Page file print ¹
Resident Fonts	80 roman outline fonts standard
Printing Protocols	LPR, IPP, PAP, Raw TCP (port 9100), FTP, NetBEUI, Novell Pserver/Printer, HTTP, POP3, SSL. ³
Network Security	IP/MAC Filtering, Protocol Disable, User Authentication

Network Scanner Expansion Kit (option)

Maximum Original Size	Up to 11" x 17"
Scan Output	200 dpi, 300 dpi, 400 dpi, 600dpi
Image Formats	Monochrome: TIFF, PDF Color: Encrypted PDF, TIFF, JPEG, PDF
Image Compression	Monochrome: Uncompressed, G3 (MH), G4 (MR/MMR) Color/Grayscale (option): High/Middle/Low
Scan Destinations	E-mail, Desktop, FTP, SMB (network folder), USB, URL, Internet fax, G3 fax ¹
Inbound Routing	G3 Fax to E-mail, Internet Fax to E-mail
One-touch Destinations	Up to 999
Group Destinations	Up to 500
Programs	48
Network Protocols	TCP/IP (includes SMTP, LDAP, FTP, POP, SMB, ESMTMP)
Network Security	E-mail server authentication and user account control, SSL. ³
Software	Sharpdesk document management (10 user license)

Super G3 Fax Kit (option)

Transmission Mode	Super G3, G3
Modem Speed	33.6 KBPS ⁵
Compression Methods	JBIG, MMR, MR, MH
Max. Transmit Resolution	400 DPI (ultra-fine)
Transmission Speed	Approximately 2 Seconds with JBIG ⁵
Auto dial Destinations	Up to 999 (combined with scan destinations)
Group Dial/Destinations	Up to 500
Long length Originals	Up to 31.5" (for transmission)
Memory	8 MB standard
Features	Inbound Routing, Forward To Administrator, F-Code, Quick On-Line, Rotation Transmit, Anti-Junk Fax, and PC fax. ¹

100 Sheet Stapler Finisher

MFP Models Supported	MX-M850; MX-M950; MX-M1100
Output Capacity	Upper tray: 500 sheets (letter, letter-R, statement size) Lower tray: Offset stack tray; 3000 sheets (letter size)
Stapling Positions	Top, top slant, bottom or 2 staples on side
Stapling Capacity	100 sheets (20 lb. bond; letter size)
Hole Punch	Optional 3 hole punch unit
Power Consumption	120 W or less
Weight	Approx. 160 lbs.
Dimensions	31 3/4" (w) x 28 3/4" (d) x 38 3/4" (h)

50 Sheet Stapler Finisher

MFP Models Supported	MX-M850
Output Capacity	Upper tray: 250 sheets (letter, statement size) Lower tray: Offset stack tray; 3000 sheets (letter size)
Stapling Positions	Top, top slant, bottom or 2 staples on side
Stapling Capacity	50 sheets (20 lb. bond; letter size)
Hole Punch	Optional 3 hole punch unit
Power Consumption	96 W or less
Weight	Approx. 101 lbs.
Dimensions	25 1/4" (w) x 24 1/4" (d) x 37 7/8" (h)

Saddle Stitch Finisher

MFP Models Supported	MX-M850
Output Trays	Upper tray: Offset stack tray Lower tray: Book tray for saddle stitch
Output Capacity	Upper tray: 250 sheets (letter, statement size) Lower tray: 2000 sheets (letter size)
Stapling Capacity	50 sheets (20 lb. bond; letter size)
Stapling Positions	Top, top slant, bottom or 2 staples on side
Saddle Stitch Function	Centerfold (2 staples); up to 12" x 18" paper sizes
Saddle Stitch Capacity	15 sheets/10 sets; 10 sheets/15 sets; 5 sheets/30 sets
Power Consumption	96 W or less
Hole Punch	Optional 3 hole punch unit
Weight	Approx. 134 lbs.
Dimensions	25 1/4" (w) x 24 1/4" (d) x 37 7/8" (h)

Optional Equipment

MX-LCX4	4550-sheet Large Capacity Three Draw Tray (letter)
MX-LCX5	4000-sheet Large Capacity Three Draw Tray (ledger)
MX-LCX6	3500-sheet Large Capacity Tray (letter) ¹
MX-LCX3N	3000-sheet Large Capacity Tray (ledger) ¹
MX-MFX1	100-Sheet Bypass Tray
MX-MFX2	500-Sheet Bypass Tray
MX-FNX5	100-Sheet Stapler Finisher
MX-FNX6	50-Sheet Stapler Finisher
MX-FNX7	Saddle Stitch Finisher
MX-FNX8	Saddle Unit (Booklet Maker) ¹
MX-CFX2	Insertion Unit ¹
MX-FOX1	Folding Unit ¹
MX-PNX3B	Hole Punch Module (for MX-FNX5)
MX-PNX4B	Hole Punch Module (for MX-FNX6 and MX-FNX7)
MX-GBCX1	GBC SmartPunch Module
MX-PBX2	PCL6 Printer Expansion Kit
MX-PKX4	PS3 Expansion Kit ¹
MX-NSX1	Network Scanner Expansion Kit
MX-EBX1	Color Expansion Kit (for scanning) ¹
MX-AMX1	Application Integration Module ¹
MX-AMX2	Sharp OSA Application Communication Module ^{1,3}
MX-AMX3	Sharp OSA External Accounting Module ^{1,3}
MX-FWX1	Internet Fax Expansion Kit ¹
MX-FXX1	Super G3 Fax Expansion Kit
AR-SU1	Stamp Unit
AR-PF1	Bar Code Font Kit ¹
MX-FRXBU	Commercial Data Security Kit ³

Supplies

MX-850NT	Toner Cartridge
MX-850NV	Developer
MX-850NR	OPC Drum
AR-SV1	Stamp Cartridge

¹ Some features require optional equipment

² Dimensions and weight include DSPF and operation panel

³ Sharp OSA[™] Integration, Data Security Kit, IPv6, SSL and IPsec support available summer 2007

⁴ PDF and Encrypted PDF require optional PS3 Expansion Kit

⁵ Based on ITU Test chart #1 in standard resolution; actual transmission time will vary based on line conditions.



SHARP®

Sharp Electronics Corporation
Sharp Plaza Mahwah, NJ 07430-2135
1-800-BE-SHARP www.sharpsusa.com

Design and specifications subject to change without notice. Sharp, Sharp OSA, Sharpdesk, My Sharp, and all related trademarks are trademarks or registered trademarks of Sharp Corporation and/or its affiliated companies. Windows, Windows NT and Windows Server are registered trademarks of Microsoft Corporation in the United States and other countries. Windows Vista is a trademark of Microsoft Corporation. All other trademarks are the property of their respective owners.

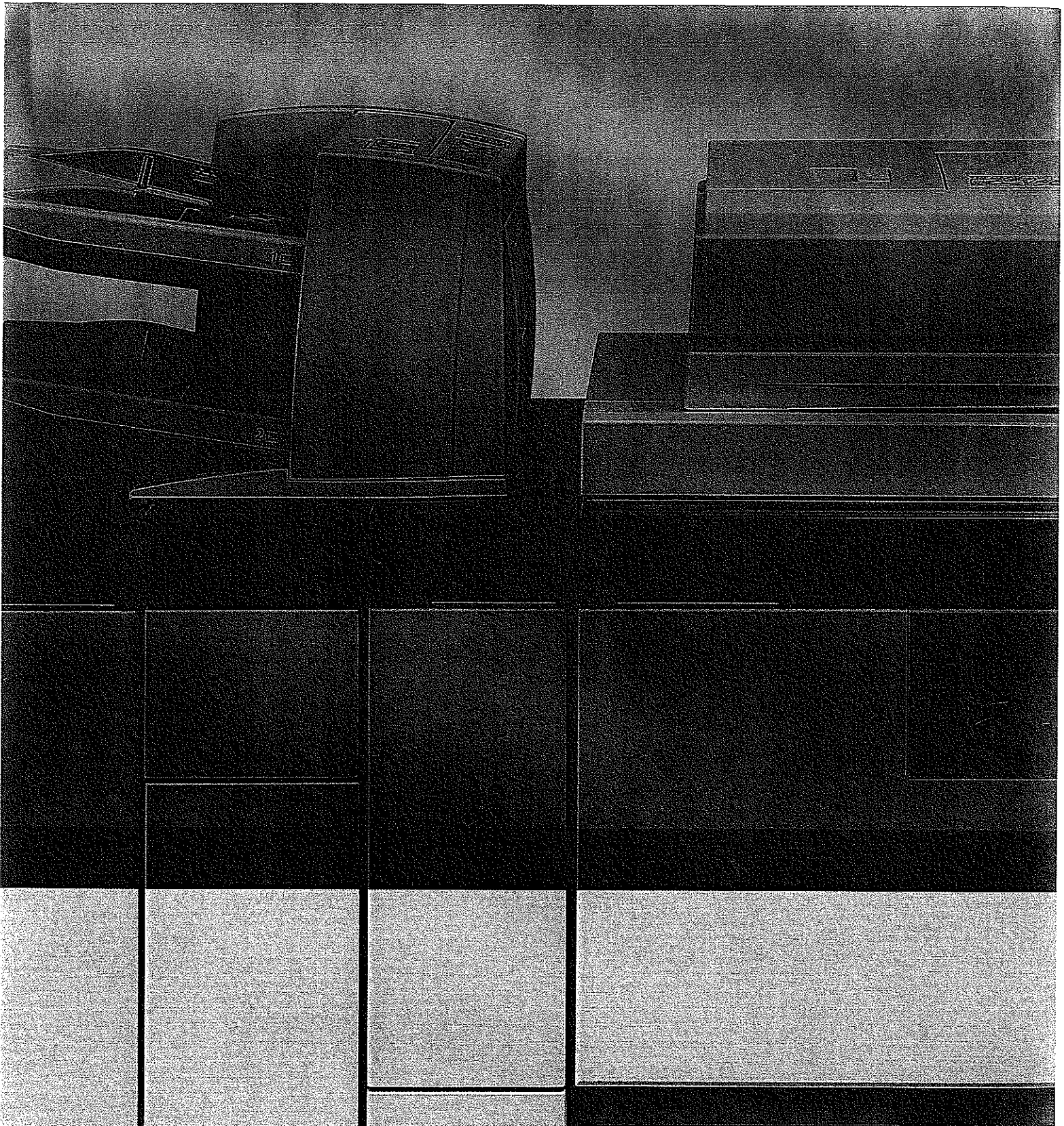

© 2007 Sharp Electronics Corporation
Printed in U.S.A.

5/07 • CPD-3790