



December 28, 2007

West Virginia Purchasing Division
Department of Administration
Building 15
2019 Washington Street, East
Charleston, WV 25305-0130

Dear Sir or Madam:

Unisys Corporation is pleased to provide the enclosed quotation for RFQ Number AUD083223.

Please review the enclosed quotations for Computer Room Air Conditioning and an Uninterruptible Power System . Should you require any additional information, please call Mr. Kennedy at 518-331-0491.

We at Unisys appreciate the continued interest of the West Virginia State Auditor's Office in our products and services.

Sincerely,

Michael Kennedy

Michael Kennedy
Portfolio Sales Executive

Lara C. Novino
Contracts Manager

RECEIVED

2007 DEC 28 A 8:15

PURCHASING DIVISION
STATE OF WV



Statement of Understanding

This proposal has been prepared in accordance with Unisys understanding of your requirements based on the information provided. All timings, flow charts, system design and related information contained in this proposal represent Unisys best estimates. However, since the actual results in your particular operations (including among other aspects speeds, personnel requirements and costs) may vary from those indicated in the proposal due to variations in software, programs, volume, environment, personnel, and other factors, the final determination that the proposed products and services meet your requirements must be yours.

This proposal contains confidential information of Unisys Corporation. In consideration of the receipt of this document, recipient agrees not to reproduce or make this information available in any manner to persons outside the group directly responsible for evaluation of its contents, except as required by law.

The Unisys products and services contained in this proposal (HVAC and UPS equipment, installation and maintenance) will be supplied under the terms and conditions set forth in the Unisys - State of West Virginia Master Agreement #95010052, a copy of which is on file at the West Virginia Department of Administration and at the West Virginia Attorney General's Office, and the attached Amendment to that Agreement which incorporates our agreement for Limitation of Liability. Should an award be made to Unisys, Client shall reference this quote on its order and include a copy of this quote and the signed Amendment.

This proposal is valid for 90 days unless extended by Unisys in writing.



Amendment to existing Master Agreement

West Virginia Purchase Requisition Number: AUD083223

Description of Product/Services: **HVAC and UPS equipment, installation and maintenance**

Total Charges of Products/Services: **\$ 497,484**

(1) Despite any terms to the contrary in the Agreement any third party commercial off the shelf (COTS) software provided under the above referenced order shall be subject to any customary license terms of the licensor that accompany the product whether in the form of a shrink wrap, click wrap, click through, browse through or any other form.

(2) In accordance with Section 14.1 of the West Virginia Master Agreement #95010052, the parties agree to the following limitation of liability for direct damages for the above referenced order.

The entire liability of Unisys and Customer's exclusive remedy for damages from any cause related to or arising out of this Agreement, regardless of form or action, will not exceed the greater of (a) \$100,000 or (b) the charges paid to Unisys during the 24 month period immediately prior to Customer's notice of intent to initiate action. Such limitation of liability shall not apply to claims for personal injury, wrongful death or tangible property damage or claims under Section 15 (Patent, Copyright and Trade Secret Indemnification).

(3) Requirements for products to operate to the "satisfaction" of the State are clarified and limited as follows:

Acceptance of equipment is limited to a test of the equipment supplied as described in item #10 on page 15 of 27 of the RFQ to verify its operability and completion of the installation service. Unisys personnel shall have the right to be present and participate in the test, and the test shall be performed within ten (10) days of Unisys notification to the State that the equipment is installed and ready for use. Test failures attributable to the electrical system, the unavailability of sufficient electrical power from the State or other matters attributable to the State or third parties are not grounds for non-acceptance of Unisys deliverables. Equipment will be deemed accepted upon the earlier of (i) receipt of written notice of acceptance from the State, (b) 10 days following installation of the equipment (as verified by Unisys notice to the State that the equipment is ready for testing) if the State has not provided a written notification of material non-conformance of the equipment with the equipment published specifications or upon (c) the state's use of the equipment in production.

UNISYS

Upon execution of this Agreement by both parties, Unisys will accept and process the order for products and/or services.

Agreed and Accepted:

UNISYS CORPORATION

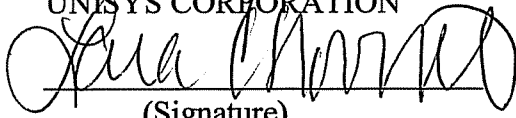

(Signature)

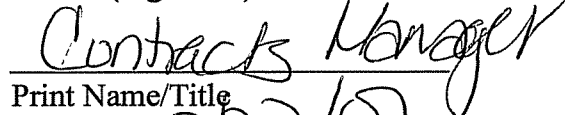

Print Name/Title

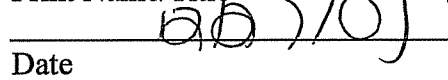

Date

WV STATE TREASURER'S OFFICE

(Signature)

Print Name/Title

Date



Amendment to existing Master Agreement

West Virginia Purchase Requisition Number: AUD083223

Description of Product/Services: **HVAC and UPS equipment, installation and maintenance**

Total Charges of Products/Services: **\$ 497,484**

(1) Despite any terms to the contrary in the Agreement any third party commercial off the shelf (COTS) software provided under the above referenced order shall be subject to any customary license terms of the licensor that accompany the product whether in the form of a shrink wrap, click wrap, click through, browse through or any other form.

(2) In accordance with Section 14.1 of the West Virginia Master Agreement #95010052, the parties agree to the following limitation of liability for direct damages for the above referenced order.

The entire liability of Unisys and Customer's exclusive remedy for damages from any cause related to or arising out of this Agreement, regardless of form or action, will not exceed the greater of (a) \$100,000 or (b) the charges paid to Unisys during the 24 month period immediately prior to Customer's notice of intent to initiate action. Such limitation of liability shall not apply to claims for personal injury, wrongful death or tangible property damage or claims under Section 15 (Patent, Copyright and Trade Secret Indemnification).

(3) Requirements for products to operate to the "satisfaction" of the State are clarified and limited as follows:

Acceptance of equipment is limited to a test of the equipment supplied as described in item #10 on page 15 of 27 of the RFQ to verify its operability and completion of the installation service. Unisys personnel shall have the right to be present and participate in the test, and the test shall be performed within ten (10) days of Unisys notification to the State that the equipment is installed and ready for use. Test failures attributable to the electrical system, the unavailability of sufficient electrical power from the State or other matters attributable to the State or third parties are not grounds for non-acceptance of Unisys deliverables. Equipment will be deemed accepted upon the earlier of (i) receipt of written notice of acceptance from the State, (b) 10 days following installation of the equipment (as verified by Unisys notice to the State that the equipment is ready for testing) if the State has not provided a written notification of material non-conformance of the equipment with the equipment published specifications or upon (c) the state's use of the equipment in production.

UNISYS

Upon execution of this Agreement by both parties, Unisys will accept and process the order for products and/or services.

Agreed and Accepted:

UNISYS CORPORATION

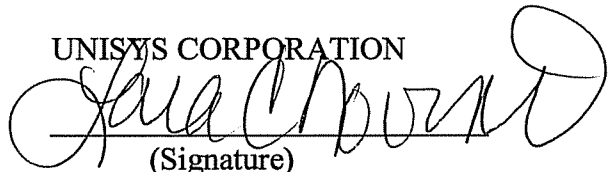

(Signature)



Print Name/Title

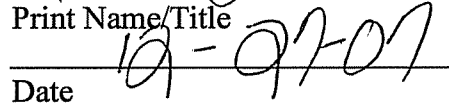

Date

WV STATE TREASURER'S OFFICE

(Signature)

Print Name/Title

Date

Unisys Proposal for
West Virginia Auditors Office
RFQ AUD083223
Data Center Environmental Systems
December 28, 2007

Proposal Response
RFQ AUD083223 Data Center Environmental Systems
December 28, 2007

I. Project Description

This proposed Statement of Work (SOW) describes the products and services to be provided to the West Virginia Auditor Office for environmental upgrades to their disaster recovery data center facility in the event of an award to Unisys based on the published requirements of RFQ AUD083223 and the terms set forth herein.

II. Project Background

The West Virginia Auditors Office (WVAO) is soliciting bids from contractors for products and services for a full turnkey* environmental solution to support both the facility and data center located at 200 West Main Street, Clarksburg, WV 26301. The major components of this RFQ are Air Conditioning, Uninterruptible Power Supply, and installation of both.

In response to the above-referenced RFQ, Unisys proposes the supply of the products and services described herein based on the requirements of the RFQ and the terms set forth herein.

* For the purposes of this proposal, the word "turnkey" shall mean: (a) the delivery and installation by Unisys of the products specified in Unisys response; (b) the testing and implementation of the products as defined in Unisys proposal; and (c) the ongoing maintenance of the products as defined in Unisys proposal in accordance with the terms and conditions of the final agreement between the parties, and specifically excluding any products and services beyond those described herein.

III. Overview of Products and Services

In the event of an award to Unisys, Unisys will provide the products and installation services described herein to upgrade the Clarksburg data center. These products and services to be provided by Unisys are as follows.

- A. One 15 ton and one 10 ton Liebert Computer Room Air Conditioners (CRACs), which will be configured such that one unit will back up the other in the event of an equipment failure or scheduled maintenance.
- B. One 40 kva Powerware Uninterruptible Power Supply (UPS) with a battery supply to last approximately one hour.
- C. Delivery, rigging and installation of the CRAC and UPS units.
- D. Start-up and testing of the installed units.

- E. Project Management
- F. Liebert and Powerware Equipment maintenance for years 2 through 5. (Year one covered under third party warranty/service plan.) Note- the quoted maintenance is for the third party manufacturer standard service offering (and not Unisys SURETY plan) for the service plans described herein.

IV. Timeframe

Upon commencement of a validly binding contract, Unisys will order the products listed in the Bill of Materials within this proposal. Manufacturers lead time for delivery of products is predicted to be approximately eight (8) weeks following acceptance by Unisys of an order from WVAO under the parties' existing agreement. Once delivered, Unisys expects the installation and testing to be complete in approximately four (4) weeks.

Timeframes are estimates and will be refined and communicated to WVAO through regular status reports provided by the Unisys Project Manager.

V. Bonds

Unisys includes the following Bonds with its quote for this project.

- Bid Bond for 5% of bid price.

Unisys understands that the State has requested a Performance Bond for 100% of Bid Price, and will comply with this requirement as part of the final contract in the event of an award to Unisys.

VI. Contractor License Number

WV 14839 Issued July 1, 2007

VII. Contact Name

Michael Kennedy
Sales Executive
10B Madison Avenue Extension
Albany, NY 12203

518-331-0491 office
518-452-6238 fax

VIII. Bill of Material

The proposed products are currently manufactured items. These products are not scheduled for discontinuance within the next three years, although continued manufacturing over this future timeframe cannot be guaranteed.

The proposed products are manufactured in the United States.

However, steel, glass and aluminum sub-components are not guaranteed to originate in the US, and Unisys is unable to agree to a certification that all or any specific proportion of those subcomponents are manufactured in the U.S.

A. Liebert 15 Ton CRAC

One (1) Liebert Model DH199A-CAEI, 208 Volts, 60Hz, 3 Phase Deluxe System/3 Environmental Control System: Nominal 15 ton Air Cooled Downflow System, MBH at 72°F, 50% RH

One (1) 95°F Ambient Fan Speed Control Condenser Model DCDF205-Y, 208/230 Volts, 60Hz, 3 Phase

- Includes Factory Wired Condenser Disconnect Switch

System Accessories:

- Advanced Microprocessor-Based Temperature and Humidity Controls
- Display Language is English
- Audible and Visual Alarms
- 3 HP Fan Motor
- 4-Step Cylinder Unloaders
- Electric Reheat
- Infrared Humidifier
- Locking Disconnect Switch
- 4" – 20% Filter Package
- 12" High Floorstand
- Turning Vanes
- Dual Float Condensate Pump
- Qty-2 LT300 Point Leak Detection Sensor
- Main Color: Unisys White (Z-0660)
- Accent Color: Unisys White (Z-0660)

Services Include:

- One year Parts only warranty

Special Features Include:

- One (1) UNISYS spec for all SYS3 or Chal3000 models. Unit to be configured & built with UNISYS labeling, identification, and instruction manuals.

B. Liebert 10 Ton CRAC**One (1) Liebert Model DH125A-CAEI, 208 Volts, 60Hz, 3 Phase Deluxe System/3**

Environmental Control System: Nominal 10 ton Air Cooled Downflow System, MBH at 72°F, 50% RH

One (1) 95°F Ambient Fan Speed Control Condenser Model DCDF165-Y, 208/230 Volts, 60Hz, 3 Phase

- Includes Factory Wired Condenser Disconnect Switch

System Accessories:

- Advanced Microprocessor-Based Temperature and Humidity Controls
- Display Language is English
- Audible and Visual Alarms
- 3 HP Fan Motor
- 4-Step Cylinder Unloaders
- Electric Reheat
- Infrared Humidifier
- Locking Disconnect Switch
- 4" – 20% Filter Package
- 12" High Floorstand
- Turning Vanes
- Dual Float Condensate Pump
- Qty-2 LT300 Point Leak Detection Sensor
- Main Color: Unisys White (Z-0660)
- Accent Color: Unisys White (Z-0660)

Services Include:

- One year Parts only warranty

Special Features Include:

- Unit to be configured & built with UNISYS labeling, identification, and instruction manuals.

C. 40 kva UPS with One Hour Batteries

Powerware 9390-80 40 kVA, On Line UPS, 40kVA/36kW. 208V in/out. Includes 3 breaker bypass sidecar cabinet. Double Conversion Topology, Unit efficiency up to 94%, Unit output rating @ 0.9 Power Factor, Input current distortion < 4.5%, Patented ABM Technology, Patented HotSync parallel firmware control, Scalable Architecture, Parallel Redundancy and Capacity capable, Variable DC bus for optimizing battery runtime options. 5x8 Start-up: PLUS One year on-site parts & labor coverage (7x24), PLUS: One year remote monitoring (Web/SNMP card w/ EMP provided upon acceptance and registration of eNotify).

UPS Cabinet Dimensions: 18.9"W x 31.6"D x 73.7"H
UPS Cabinet Weight: 640 lbs.

Powerware Part Number: TB0411300033010 Quantity: 1

Battery Cabinet System, (1) IBC-L Integrated Battery Cabinet, 480 VDC . Back-up time @ 0.9pf (40 kVA/36kW) 66 minutes

Battery Cabinet Dimensions: 42.7"W x 31.6"D x 73.7"H
Battery Cabinet Weight: 4785 lbs.

Powerware Part Number: TL0403B47111100 Quantity: 1

IX. Equipment Maintenance

A. Liebert

The following services are included in this bid.

- 1st year labor standard service: Liebert 1st year standard parts only plus 1st year labor assistance to replace failed in-warranty parts only (Labor to be provided by Liebert USA contractors only).
- Extended compressor warranty for years 2 through 5
- Factory Supervised Warranty Inspection and Basic Operator Training and Warranty Inspection Start-up
- Liebert maintenance service for years 2 through 5

B. Powerware

PowerTrust Service Plans, post warranty for the PW9390 for years 2 through 5.

X. Statement of Work

The following activities will be performed during the installation of one 80 KVA UPS, one 10 ton and one 15 ton Computer Room Air Conditioner (CRAC).

- All labor and material for installation with the exception of electrical feeds.
- Receiving and rigging UPS equipment into position.
- Supplying additional floor pedestals to support the UPS.
- Installing batteries in UPS battery rack.
- Cutting access flooring as necessary for installation of CRAC floor stands.
- Receiving and rigging CRAC equipment into position.
- Supplying floor protection as necessary.
- Engineering expenses for rigging equipment only.

- Opening windows and doorways in rear of building to accommodate equipment installation.
- Returning windows and doorways to existing conditioning after equipment installation.
- Installing one 10 ton and one 15 ton CRAC units with air cooled roof top condensers.
- Permit fees.
- Startup of equipment using factory-authorized technicians.
- Testing of equipment following startup.
- Project Management- consisting of services to manage and provide oversight of the performance of the Unisys services quoted herein

XI. Part Supply Infrastructure

A. Liebert

The primary Liebert parts depots housing all replacement parts for United States are in Columbus, OH and Ironton, OH. For the equipment proposed here, Liebert Deluxe System/3 units, the replacement parts warehouse is based in Columbus.

It is normal operating procedure to ship, usually overnight, parts that are needed under emergency conditions. Parts are shipped directly to the address of the owner or alternately to the address of the contractor responsible for repair work.

B. Powerware

Parts supplies are located in the field to provide approximately 80% of all emergency needs. The factory serves as the central stocking facility where a dedicated supply of all parts is available within 24 hours. Parts are manufactured and centrally warehoused in Raleigh, North Carolina; batteries are located in approximately ten (10) regional stocking locations in addition to the Raleigh logistic center. Most parts and common battery types are available within 24 hours or less.

XII. References

The following references are customers where Unisys has installed equipment similar to that proposed here.

A. Liebert

1. Union Centre National Bank, NJ quantity 3 - 10 ton Unisys/Liebert Deluxe Systems HVAC - Barbara Liebman - 908-206-2956
2. Yardville National Bank, NJ quantity 2 - 8 ton Unisys/Liebert Deluxe Systems HVAC - Rich Kaufman - 609-689-8040
3. Best Buy, NY 20 ton Unisys/Liebert Deluxe System HVAC - Audra Ellis - 607-689-8040

B. Powerware

1. Wachovia Dealer Services, Inc., Irving, CA Gregory Spivey 800-289-8004
2. New York State Insurance Fund, Albany, NY, Jeffrey Digman 518-437-6400
3. Charmer Sunbelt Group, Baltimore, MD, Robert Valentin 410-401-9390

XIII. Assumptions and Exclusions/Exceptions

Unisys proposal and the pricing set forth herein are based on the following assumptions and expectations. Changes in any of the assumptions may result in an equitable adjustment in the work, schedule and/or price.

1. Unisys assumes that the worksite is free of asbestos or other environmental hazards. We reserve the right to immediately suspend work and terminate if we find environmental hazard problems.
2. Unisys assumes Union Labor is not required. Prevailing Rate wages will be paid.
3. Unisys assumes that the building is structurally sound to accommodate this equipment installation.
4. Unisys expects to remove a window and door in the rear of the building to allow the rigging of large items into the building. Unisys will return the window and door to equal or better condition.
5. Electrical power for the HVAC and UPS system, including without limitations electrical connections to the installed equipment, is to be provided by the State or third parties employed directly by the State. Unisys is not responsible for providing such items.
6. Adequate electrical power meeting equipment manufacturer recommendations must be available for product testing no later than 10 days following the installation of the equipment.
7. Unisys assumes that a Building Permit and an Electrical Permit will be required. Unisys will bear the cost for these two permits but expects WVAO to assist in their preparation if required. Additional permits are not included.
8. Unisys assumes that appropriate access to necessary facility areas will be provided by WVAO to enable our performance of the services. This may include off-hour access such as early morning, late evening or weekend.
9. Unisys is unable to agree to a certification that all or any specific proportion of those subcomponents of the quoted products are manufactured in the U.S.
10. Unisys assumes that normal work hours will be 8:00am to 5:00pm M-F. Work beyond normal hours will be subject to the agreement of both parties.
11. Any architectural, engineering, or structural work related to this project out-of-scope.
12. Unisys assumes that provision and installation of an emergency generator is not required in this RFQ response even though the generator is mentioned in the engineering reports.

XIV. Pricing

Summary Cost Sheet

HVAC Total	57,033
UPS Total	64,491

Maintenance	71,300
Delivery	3,603
Hardware components and Cables	Included
Consumable Supplies	N/A
Documentation	Included
Training	2,486
Other	298,571
Total	497,484

Payment for the services within this SOW will be invoiced upon completion of the installation services (Unisys notification that the products are ready for testing).

Products will be invoiced upon acceptance in accordance with the acceptance terms outlined in the Amendment to the Agreement included in this response.

All of the above charges represent Unisys prices and the proposed costs to the State for the products and services detailed herein.

XV. Required Forms

- Purchasing Affidavit- included
- Insurance Certificate- will be provided upon award
- Bid Bond- included



State of West Virginia
 Department of Administration
 Purchasing Division
 2019 Washington Street East
 Post Office Box 50130
 Charleston, WV 25305-0130

Request for Quotation

RFQ NUMBER
AUD083223

PAGE
1

ADDRESS CORRESPONDENCE TO ATTENTION OF
**RON PRICE
 304-558-0492**

VENDOR

RFQ COPY
 TYPE NAME/ADDRESS HERE
 Unisys Corporation
 Unisys Way
 Blue Bell PA 19424

SHIP TO

STATE AUDITOR'S OFFICE
 BUILDING 1, ROOM W100
 1900 KANAWHA BOULEVARD, EAST
 CHARLESTON, WV
 25305-0230 558-2251

DATE PRINTED	TERMS OF SALE	SHIP VIA	F.O.B.	FREIGHT TERMS
11/27/2007				

BID OPENING DATE: **12/19/2007** BID OPENING TIME **01:30PM**

LINE	QUANTITY	UOP	CAT NO.	ITEM NUMBER	UNIT PRICE	AMOUNT
0001	1	LS		031-06		
<p>HVAC/UPS SYSTEM</p> <p>TO PROVIDE AND INSTALL HVAC/UPS SYSTEM AS PER THE ATTACHED SPECIFICATIONS</p> <p>A MANDATORY ON-SITE PRE-BID WILL BE HELD ON 12/5/07 AT 10:30 AM AT 200 WEST MAIN STREET, CLARKSBURG, WV. FAILURE TO ATTEND THE PRE-BID SHALL RESULT IN DISQUALIFICATION OF THE BID. NO ONE PERSON CAN REPRESENT MORE THAN ONE BIDDER.</p> <p>VENDOR SHOULD INDICATE THE TIME FRAME FOR COMPLETION AFTER NOTICE TO PROCEED. THE TIME FRAME SHOULD BE INCLUDED WITH THE BID, BUT WILL BE REQUIRED PRIOR TO THE AWARD OF THE PURCHASE ORDER.</p> <p>NUMBER OF DAYS TO COMPLETE -----</p> <p>WRITTEN QUESTIONS MAY BE SUBMITTED UNTIL 4:00 PM ON DECEMBER 7, 2007 TO THE FOLLOWING:</p> <p>RON PRICE PURCHASING DIVISION 2019 WASHINGTON STREET, EAST CHARLESTON, WV 25305 FAX: 304.558.4115 EMAIL: RPRICE@WVADMIN.GOV</p> <p>PREFERENCE FOR USE OF DOMESTIC STEEL PRODUCTS</p>						

SEE REVERSE SIDE FOR TERMS AND CONDITIONS

SIGNATURE <i>[Signature]</i>	TELEPHONE <i>2159806614</i>	DATE <i>12/27/07</i>
TITLE <i>Contracts Manager</i>	ADDRESS CHANGES TO BE NOTED ABOVE	

WHEN RESPONDING TO RFQ, INSERT NAME AND ADDRESS IN SPACE ABOVE LABELED 'VENDOR'

**GENERAL TERMS & CONDITIONS
REQUEST FOR QUOTATION (RFQ) AND REQUEST FOR PROPOSAL (RFP)**

1. Awards will be made in the best interest of the State of West Virginia.
2. The State may accept or reject in part, or in whole, any bid.
3. All quotations are governed by the *West Virginia Code* and the *Legislative Rules* of the Purchasing Division.
4. Prior to any award, the apparent successful vendor must be properly registered with the Purchasing Division and have paid the required \$125.00 registration fee.
5. All services performed or goods delivered under State Purchase Orders/Contracts are to be continued for the term of the Purchase Order/Contract, contingent upon funds being appropriated by the Legislature or otherwise being made available. In the event funds are not appropriated or otherwise available for these services or goods, this Purchase Order/Contract becomes void and of no effect after June 30.
6. Payment may only be made after the delivery and acceptance of goods or services.
7. Interest may be paid for late payment in accordance with the *West Virginia Code*.
8. Vendor preference will be granted upon written request in accordance with the *West Virginia Code*.
9. The State of West Virginia is exempt from federal and state taxes and will not pay or reimburse such taxes.
10. The Director of Purchasing may cancel any Purchase Order/Contract upon 30 days written notice to the seller.
11. The laws of the State of West Virginia and the *Legislative Rules* of the Purchasing Division shall govern all rights and duties under the Contract, including without limitation the validity of this Purchase Order/Contract.
12. Any reference to automatic renewal is hereby deleted. The Contract may be renewed only upon mutual written agreement of the parties.
13. **BANKRUPTCY:** In the event the vendor/contractor files for bankruptcy protection, this Contract may be deemed null and void, and terminated without further order.
14. **HIPAA Business Associate Addendum -** The West Virginia State Government HIPAA Business Associate Addendum (BAA), approved by the Attorney General, and available online at the Purchasing Division's web site (<http://www.state.wv.us/admin/purchase/vrc/hipaa.htm>) is hereby made part of the agreement. Provided that, the Agency meets the definition of a Covered Entity (45 CFR §160.103) and will be disclosing Protected Health Information (45 CFR §160.103) to the vendor.

INSTRUCTIONS TO BIDDERS

1. Use the quotation forms provided by the Purchasing Division.
2. **SPECIFICATIONS:** Items offered must be in compliance with the specifications. Any deviation from the specifications must be clearly indicated by the bidder. Alternates offered by the bidder as **EQUAL** to the specifications must be clearly defined. A bidder offering an alternate should attach complete specifications and literature to the bid. The Purchasing Division may waive minor deviations to specifications.
3. Complete all sections of the quotation form.
4. Unit prices shall prevail in cases of discrepancy.
5. All quotations are considered F.O.B. destination unless alternate shipping terms are clearly identified in the quotation.
6. **BID SUBMISSION:** All quotations must be delivered by the bidder to the office listed below prior to the date and time of the bid opening. Failure of the bidder to deliver the quotations on time will result in bid disqualifications.

SIGNED BID TO:

Department of Administration
Purchasing Division
2019 Washington Street East
Post Office Box 50130
Charleston, WV 25305-0130



State of West Virginia
 Department of Administration
 Purchasing Division
 2019 Washington Street East
 Post Office Box 50130
 Charleston, WV 25305-0130

Request for Quotation

RFQ NUMBER:
AUD083223

PAGE:
2

ADDRESS CORRESPONDENCE TO ATTENTION OF:
**RDN PRICE
 304-558-0492**

VENDOR

RFQ COPY
TYPE NAME/ADDRESS HERE
 Unisys Corporation
 Unisys Way
 Blue Bell Pa 19424

SHIP TO

STATE AUDITOR'S OFFICE
BUILDING 1, ROOM W100
1900 KANAWHA BOULEVARD, EAST
CHARLESTON, WV
25305-0230 558-2251

DATE PRINTED	TERMS OF SALE	SHIP VIA	FOB	FREIGHT TERMS
11/27/2007				

BID OPENING DATE: 12/19/2007 BID OPENING TIME 01:30PM

LINE	QUANTITY	UOP	CAT NO	ITEM NUMBER	UNIT PRICE	AMOUNT
1.						
<p>EXCEPT WHEN AUTHORIZED BY THE DIRECTOR OF THE PURCHASING DIVISION PURSUANT TO SUBSECTION 2 BELOW, NO CONTRACTOR MAY USE OR SUPPLY STEEL PRODUCTS FOR A STATE CONTRACT PROJECT OTHER THAN THOSE STEEL PRODUCTS MADE IN THE UNITED STATES. AS USED IN THIS CONTRACT,</p> <p>A. "STATE CONTRACT PROJECT" MEANS ANY ERECTION OR CONSTRUCTION OF, OR ANY ADDITION TO, ALTERATION OF OR OTHER IMPROVEMENT TO ANY BUILDING OR STRUCTURE, INCLUDING, BUT NOT LIMITED TO, ROADS OR HIGHWAYS, OR THE INSTALLATION OF ANY HEATING OR COOLING OR VENTILATING PLANTS OR OTHER EQUIPMENT, OR THE SUPPLY OF AND MATERIALS FOR SUCH PROJECTS, PURSUANT TO A CONTRACT WITH THE STATE OF WEST VIRGINIA FOR WHICH BIDS WERE SOLICITED ON OR AFTER JUNE 6, 2001.</p> <p>B. "STEEL PRODUCTS" MEANS PRODUCTS ROLLED, FORMED, SHAPED, DRAWN, EXTRUDED, FORGED, CAST, FABRICATED OR OTHERWISE SIMILARLY PROCESSED, OR PROCESSED BY A COMBINATION OF TWO OR MORE OF SUCH OPERATIONS, FROM STEEL MADE BY THE OPEN HEARTH, BASIC OXYGEN, ELECTRIC FURNACE, BESSEMER OR OTHER STEEL MAKING PROCESS.</p> <p>C. "UNITED STATES" MEANS THE UNITED STATES OF AMERICA AND INCLUDES ALL TERRITORY, CONTINENTAL OR INSULAR, SUBJECT TO THE JURISDICTION OF THE UNITED STATES.</p>						
2.						
<p>THE DIRECTOR OF THE PURCHASING DIVISION MAY, IN WRITING, AUTHORIZE THE USE OF FOREIGN STEEL PRODUCTS IF:</p> <p>A. THE COST FOR EACH CONTRACT ITEM USED DOES NOT</p>						

SEE REVERSE SIDE FOR TERMS AND CONDITIONS

SIGNATURE <i>[Signature]</i>	TELEPHONE 2159866664	DATE 12/17/07
TITLE Contracts Manager	FON 380387840	ADDRESS CHANGES TO BE NOTED ABOVE

WHEN RESPONDING TO RFQ, INSERT NAME AND ADDRESS IN SPACE ABOVE LABELED 'VENDOR'



State of West Virginia
 Department of Administration
 Purchasing Division
 2019 Washington Street East
 Post Office Box 50130
 Charleston, WV 25305-0130

Request for Quotation

RFQ NUMBER
AUD083223

PAGE
3

ADDRESS CORRESPONDENCE TO ATTENTION OF
RON PRICE
304-558-0492

RFQ COPY

TYPE NAME/ADDRESS HERE
Unisys Corporation
Unisys Way
BlueBell Pa 19424

STATE AUDITOR'S OFFICE

STATE AUDITOR'S OFFICE
 BUILDING 1, ROOM W100
 1900 KANAWHA BOULEVARD, EAST
 CHARLESTON, WV
 25305-0230 558-2251

DATE PRINTED	TERMS OF SALE	SHIP VIA	F.O.B.	FREIGHT TERMS
11/27/2007				

BID OPENING DATE: **12/19/2007** BID OPENING TIME **01:30PM**

LINE	QUANTITY	UOP	CAT NO	ITEM NUMBER	UNIT PRICE	AMOUNT
<p>EXCEED ONE TENTH OF ONE PERCENT (.1%) OF THE TOTAL CONTRACT COST OR TWO THOUSAND FIVE HUNDRED DOLLARS (2,500.00), WHICHEVER IS GREATER. FOR THE PURPOSES OF THIS SECTION, THE COST IS THE VALUE OF THE STEEL PRODUCT AS DELIVERED TO THE PROJECT OR,</p> <p>B. THE DIRECTOR OF THE PURCHASING DIVISION DETERMINES THAT SPECIFIED STEEL MATERIALS ARE NOT PRODUCED IN THE UNITED STATES IN SUFFICIENT QUANTITY OR OTHERWISE ARE NOT REASONABLY AVAILABLE TO MEET CONTRACT REQUIREMENTS.</p> <p>3. A CONTRACTOR WHO USES STEEL PRODUCTS IN VIOLATION OF THIS SECTION MAY BE SUBJECT TO CIVIL PENALTIES PURSUANT TO WV CODE SECTION 5A-3-56.</p> <p>REV. 10/01/01</p> <p>EXHIBIT 5</p> <p>NOTICE TO PROCEED: THIS CONTRACT IS TO BE PERFORMED WITHIN XXXX CALENDAR DAYS AFTER THE NOTICE TO PROCEED IS RECEIVED. UNLESS OTHERWISE SPECIFIED, THE FULLY EXECUTED PURCHASE ORDER WILL BE CONSIDERED NOTICE TO PROCEED.</p> <p>CANCELLATION: THE DIRECTOR OF PURCHASING RESERVES THE RIGHT TO CANCEL THIS CONTRACT IMMEDIATELY UPON WRITTEN NOTICE TO THE VENDOR IF THE MATERIALS OR WORKMANSHIP SUPPLIED ARE OF AN INFERIOR QUALITY OR DO NOT CONFORM WITH THE SPECIFICATIONS OF THE BID AND CONTRACT HERE IN.</p>						

SEE REVERSE SIDE FOR TERMS AND CONDITIONS

SIGNATURE <i>[Signature]</i>	TELEPHONE <i>359866614</i>	DATE <i>12/17/07</i>
TITLE <i>Contracts Manager</i>	FEIN <i>380387840</i>	ADDRESS CHANGES TO BE NOTED ABOVE

WHEN RESPONDING TO RFQ, INSERT NAME AND ADDRESS IN SPACE ABOVE LABELED 'VENDOR'



State of West Virginia
 Department of Administration
 Purchasing Division
 2019 Washington Street East
 Post Office Box 50130
 Charleston, WV 25305-0130

Request for Quotation

RFQ NUMBER:
AUD083223

PAGE:
4

ADDRESS CORRESPONDENCE TO ATTENTION OF:
**RON PRICE
 304-558-0492**

VENDOR

RFQ COPY
 TYPE NAME/ADDRESS HERE

*Unisys Corporation
 Unisys Way
 Blue Bell Pa 19424*

SHIP TO

STATE AUDITOR'S OFFICE
 BUILDING 1, ROOM W100
 1900 KANAWHA BOULEVARD, EAST
 CHARLESTON, WV
 25305-0230 558-2251

DATE PRINTED	TERMS OF SALE	SHIP VIA	F.O.B.	FREIGHT TERMS
11/27/2007				

BID OPENING DATE: **12/19/2007** BID OPENING TIME **01:30PM**

LINE	QUANTITY	UOP	CAT NO	ITEM NUMBER	UNIT PRICE	AMOUNT
<p>WAGE RATES: THE CONTRACTOR OR SUBCONTRACTOR SHALL PAY THE HIGHER OF THE U.S. DEPARTMENT OF LABOR MINIMUM WAGE RATES AS ESTABLISHED FOR HARRISON COUNTY, PURSUANT TO WEST VIRGINIA CODE 21-5A, ET, SEQ. (PREVAILING WAGE RATES APPLY TO THIS PROJECT)</p> <p>ARBITRATION: ANY REFERENCES MADE TO ARBITRATION OR INTEREST FOR PAYMENTS DUE (EXCEPT FOR ANY INTEREST REQUIRED BY STATE LAW) CONTAINED IN THIS CONTRACT OR IN ANY AMERICAN INSTITUTE OF ARCHITECTS DOCUMENTS PERTAINING TO THIS CONTRACT ARE HEREBY DELETED.</p> <p>WORKERS' COMPENSATION: VENDOR IS REQUIRED TO PROVIDE A CERTIFICATE FROM WORKERS' COMPENSATION IF SUCCESSFUL.</p> <p>ALL OF THE ITEMS CHECKED BELOW WILL BE A REQUIREMENT OF THIS CONTRACT:</p> <p>(XX) INSURANCE: SUCCESSFUL VENDOR SHALL FURNISH PROOF OF COMMERCIAL GENERAL LIABILITY INSURANCE PRIOR TO ISSUANCE OF CONTRACT. UNLESS OTHERWISE SPECIFIED IN THE BID DOCUMENTS, THE MINIMUM AMOUNT OF INSURANCE COVERAGE REQUIRED IS \$250,000.</p> <p>() BUILDERS RISK INSURANCE: SUCCESSFUL VENDOR SHALL FURNISH PROOF OF BUILDERS RISK - ALL RISK INSURANCE IN AN AMOUNT EQUAL TO 100% OF THE AMOUNT OF THE CONTRACT.</p> <p>(XX) BONDS: FIVE PERCENT (5%) OF THE TOTAL AMOUNT OF THE BID PAYABLE TO THE STATE OF WEST VIRGINIA, SHALL B SUBMITTED WITH EACH BID AS A BID BOND. THE SUCCESSFUL BIDDER SHALL ALSO FURNISH A PERFORMANCE BOND AND LABOR/MATERIAL BOND FOR 100% OF THE AMOUNT OF THE CONTRACT. BONDS MAY BE PROVIDED IN THE FORM OF A CERTIFIED CHECK, IRREVOCABLE LETTER OF CREDIT, OR BOND FURNISHED BY A SOLVENT SURETY COMPANY AUTHORIZED TO DO BUSINESS IN TH</p>						

SEE REVERSE SIDE FOR TERMS AND CONDITIONS

SIGNATURE: *[Signature]* TELEPHONE: *215 986 6614* DATE: *12/27/07*
 TITLE: *Contract Manager* FEIN: *380387840* ADDRESS CHANGES TO BE NOTED ABOVE

WHEN RESPONDING TO RFQ, INSERT NAME AND ADDRESS IN SPACE ABOVE LABELED 'VENDOR'



State of West Virginia
 Department of Administration
 Purchasing Division
 2019 Washington Street East
 Post Office Box 50130
 Charleston, WV 25305-0130

Request for Quotation

RFQ NUMBER:
AUD083223

PAGE:
5

ADDRESS CORRESPONDENCE TO ATTENTION OF:
**RON PRICE
 304-558-0492**

PURCHASER

RFQ COPY
 TYPE NAME/ADDRESS HERE

*Unisys Corporation
 Unisys Way
 Blue Bell Pa 19424*

SHIP TO

STATE AUDITOR'S OFFICE
 BUILDING 1, ROOM W100
 1900 KANAWHA BOULEVARD, EAST
 CHARLESTON, WV
 25305-0230 558-2251

DATE PRINTED	TERMS OF SALE	SHIP VIA	FOB	FREIGHT TERMS
11/27/2007				

BID OPENING DATE: **12/19/2007** BID OPENING TIME **01:30PM**

LINE	QUANTITY	UOP	CAT NO	ITEM NUMBER	UNIT PRICE	AMOUNT
				<p>STATE OF WEST VIRGINIA. A LETTER OF CREDIT SUBMITTED IN LIEU OF A PERFORMANCE AND LABOR & MATERIAL BOND WILL ONLY BE ALLOWED FOR PROJECTS UNDER \$100,000. PERSONAL OR BUSINESS CHECKS ARE NOT ACCEPCTABLE IN LIEU OF THE 5% BID BOND, PERFORMANCE BOND, OR LABOR AND MATERIAL BOND.</p> <p>REV. 11/00</p> <p>EXHIBIT 7</p> <p>DOMESTIC ALUMINUM, GLASS & STEEL IN PUBLIC WORKS PROJECTS</p> <p>IN ACCORDANCE WITH WEST VIRGINIA CODE 5-19-1 ET., SEQ., EVERY CONTRACT FOR CONSTRUCTION, RECONSTRUCTION, ALTERATION, REPAIR, IMPROVEMENT OR MAINTENANCE OF PUBLIC WORKS, WHERE THE COST IS MORE THAN \$50,000 AND, IN THE CASE OF STEEL ONLY, WHERE THE COST OF STEEL IS MORE THAN \$50,000 OR WHERE MORE THAN 10,000 POUNDS OF STEEL ARE REQUIRED, THE STATE WILL ACCEPT ONLY ALUMINUM GLASS, OR STEEL PRODUCTS PRODUCED IN THE UNITED STATES IN ADDITION, ITEMS OF MACHINERY OR EQUIPMENT PURCHASED FOR USE AT THE SITE OF PUBLIC WORKS SHALL BE MADE OF DOMESTIC ALUMINUM, GLASS OR STEEL, UNLESS THE COST OF THE PRODUCT IS LESS THAN \$50,000 OR LESS THAN 10,000 POUNDS OF STEEL ARE USED IN PUBLIC WORKS PROJECTS.</p> <p>FOREIGN MADE ALUMINUM, GLASS OR STEEL PRODUCTS MAY BE ACCEPTED ONLY IF THE COST OF DOMESTIC PRODUCTS IS FOUND TO BE UNREASONABLE. SUCH COST IS UNREASONABLE IF IT IS 20% OR MORE HIGHER THAN THE BID PRICE FOR FOREIGN MADE PRODUCTS. IF THE DOMESTIC ALUMINUM, GLASS OR STEEL PRODUCTS TO BE SUPPLIED OR PRODUCED IN A "SUBSTANTIAL</p>		

SEE REVERSE SIDE FOR TERMS AND CONDITIONS

SIGNATURE <i>Anna C. ...</i>	TELEPHONE <i>215 986 6614</i>	DATE <i>12/27/07</i>
TITLE <i>Contracts Manager</i>	FEIN <i>380387840</i>	ADDRESS CHANGES TO BE NOTED ABOVE

WHEN RESPONDING TO RFQ, INSERT NAME AND ADDRESS IN SPACE ABOVE LABELED 'VENDOR'



State of West Virginia
 Department of Administration
 Purchasing Division
 2019 Washington Street East
 Post Office Box 50130
 Charleston, WV 25305-0130

Request for Quotation

RFQ NUMBER
AUD083223

PAGE
6

ADDRESS CORRESPONDENCE TO ATTENTION OF
RON PRICE
304-558-0492

VENDOR

RFQ COPY
 TYPE NAME/ADDRESS HERE

Unisys Corporation
Unisys Way
Blue Bell, Pa 19424

SHIP TO

STATE AUDITOR'S OFFICE
 BUILDING 1, ROOM W100
 1900 KANAWHA BOULEVARD, EAST
 CHARLESTON, WV
 25305-0230 558-2251

DATE PRINTED	TERMS OF SALE	SHIP VIA	F.O.B.	FREIGHT TERMS
11/27/2007				

BID OPENING DATE: **12/19/2007** BID OPENING TIME **01:30PM**

LINE	QUANTITY	UOP	CAT NO	ITEM NUMBER	UNIT PRICE	AMOUNT
<p>LABOR SURPLUS AREA", AS DEFINED BY THE UNITED STATES DEPARTMENT OF LABOR, FOREIGN PRODUCTS MAY BE SUPPLIED ONLY IF DOMESTIC PRODUCTS ARE 30% OR MORE HIGHER IN PRICE THAN THE FOREIGN MADE PRODUCTS.</p> <p>IF, PRIOR TO THE AWARD OF A CONTRACT UNDER THE ABOVE PROVISIONS, THE SPENDING OFFICER OF THE SPENDING UNIT DETERMINES THAT THERE EXISTS A BID FOR LIKE FOREIGN ALUMINUM, GLASS OR STEEL THAT IS REASONABLE AND LOWER THAN THE LOWEST BID DOMESTIC PRODUCTS, THE SPENDING OFFICE MAY REQUEST, IN WRITING, A REEVALUATION AND REDUCTION IN THE LOWEST BID FOR SUCH DOMESTIC PRODUCTS ALL VENDORS MUST INDICATE IN THEIR BID IF THEY ARE SUPPLYING FOREIGN ALUMINUM, GLASS OR STEEL.</p> <p>REV. 3/88</p> <p>EXHIBIT 9</p> <p>NOTICE FOR ISSUANCE & ACKNOWLEDGEMENT OF CONSTRUCTION PROJECT ADDENDA</p> <p>THE ARCHITECT/ENGINEER AND/OR AGENCY SHALL BE REQUIRED TO ABIDE BY THE FOLLOWING SCHEDULE IN ISSUING CONSTRUCTION PROJECT ADDENDA FOR STATE AGENCIES:</p> <p>(1) THE ARCHITECT/ENGINEER SHALL PREPARE THE ADDENDUM AND A LIST OF ALL PARTIES THAT HAVE PROCURED DRAWINGS AND SPECIFICATIONS FOR THE PROJECT. THE ADDENDUM AND LIST SHALL BE FORWARDED TO THE BUYER IN THE STATE PURCHASING DIVISION. THE ARCHITECT/ENGINEER SHALL ALSO SEND A COPY OF THE ADDENDUM TO THE STATE AGENCY FOR WHICH THE CONTRACT IS ISSUED.</p> <p>(2) THE BUYER SHALL SEND THE ADDENDUM TO ALL</p>						

SEE REVERSE SIDE FOR TERMS AND CONDITIONS

SIGNATURE <i>Karla Connor</i>	TELEPHONE <i>2159866614</i>	DATE <i>12/27/07</i>
TITLE <i>Contract Manager</i>	FEIN <i>380387840</i>	ADDRESS CHANGES TO BE NOTED ABOVE

WHEN RESPONDING TO RFQ, INSERT NAME AND ADDRESS IN SPACE ABOVE LABELED 'VENDOR'



State of West Virginia
 Department of Administration
 Purchasing Division
 2019 Washington Street East
 Post Office Box 50130
 Charleston, WV 25305-0130

Request for Quotation

RFQ NUMBER
AUD083223

PAGE
7

ADDRESS CORRESPONDENCE TO ATTENTION OF
RON PRICE
304-558-0492

RFQ COPY

TYPE NAME/ADDRESS HERE

Unisys Corporation
Unisys Way
Blue Bell Pa 19424

SHIP TO

STATE AUDITOR'S OFFICE
 BUILDING 1, ROOM W100
 1900 KANAWHA BOULEVARD, EAST
 CHARLESTON, WV
 25305-0230 558-2251

DATE PRINTED	TERMS OF SALE	SHIP VIA	FOB	FREIGHT TERMS
11/27/2007				

BID OPENING DATE: **12/19/2007** BID OPENING TIME **01:30PM**

LINE	QUANTITY	UOP	CAT NO	ITEM NUMBER	UNIT PRICE	AMOUNT
<p>INTERESTED PARTIES AND, IF NECESSARY, EXTEND THE BID OPENING DATE. ANY ADDENDUM SHOULD BE RECEIVED BY THE BUYER WITHIN FOURTEEN (14) DAYS PRIOR TO THE BID OPENING DATE.</p> <p>(3) ALL ADDENDA SHOULD BE FORMALLY ACKNOWLEDGED BY ALL BIDDERS AND SUBMITTED TO THE STATE PURCHASING DIVISION. THE SAME RULES AND REGULATIONS THAT APPLY TO THE ORIGINAL BIDDING DOCUMENT SHALL ALSO APPLY TO AN ADDENDUM DOCUMENT. THE ONLY EXCEPTION MAY BE FOR AN ADDENDUM THAT IS ISSUED FOR THE SOLE PURPOSE OF CHANGING A BID OPENING TIME AND/OR DATE.</p> <p>REV. 11/96</p> <p>EXHIBIT 10</p> <p>ADDENDUM ACKNOWLEDGEMENT</p> <p>I HEREBY ACKNOWLEDGE RECEIPT OF THE FOLLOWING CHECKED ADDENDUM(S) AND HAVE MADE THE NECESSARY REVISIONS TO MY PROPOSAL, PLANS AND/OR SPECIFICATION, ETC.</p> <p>ADDENDUM NOS.:</p> <p>NO. 1 ✓</p> <p>NO. 2 ✓</p> <p>NO. 3 ✓</p> <p>NO. 4 ✓</p> <p>NO. 5 ✓</p>						

SEE REVERSE SIDE FOR TERMS AND CONDITIONS

SIGNATURE *[Signature]* TELEPHONE *215 9866614* DATE *12/17/07*

TITLE *Contracts Mgr.* FEIN *380387840* ADDRESS CHANGES TO BE NOTED ABOVE

WHEN RESPONDING TO RFQ, INSERT NAME AND ADDRESS IN SPACE ABOVE LABELED 'VENDOR'



State of West Virginia
 Department of Administration
 Purchasing Division
 2019 Washington Street East
 Post Office Box 50130
 Charleston, WV 25305-0130

Request for Quotation

RFQ NUMBER:
AUD083223

PAGE:
8

ADDRESS CORRESPONDENCE TO ATTENTION OF:
**RON PRICE
 304-558-0492**

RFQ COPY

TYPE NAME/ADDRESS HERE
*Unisys Corporation
 Unisys Way
 Blue Bell Pa 19424*

STATE AUDITOR'S OFFICE

STATE AUDITOR'S OFFICE
 BUILDING 1, ROOM W100
 1900 KANAWHA BOULEVARD, EAST
 CHARLESTON, WV
 25305-0230 558-2251

DATE PRINTED	TERMS OF SALE	SHIP VIA	FOB	FREIGHT TERMS
11/27/2007				

BID OPENING DATE: **12/19/2007** BID OPENING TIME **01:30PM**

LINE	QUANTITY	UOP	CAT NO	ITEM NUMBER	UNIT PRICE	AMOUNT
<p>I UNDERSTAND THAT FAILURE TO CONFIRM THE RECEIPT OF THE ADDENDUM(S) MAY BE CAUSE FOR REJECTION OF THE BIDS.</p> <p>VENDOR MUST CLEARLY UNDERSTAND THAT ANY VERBAL REPRESENTATION MADE OR ASSUMED TO BE MADE DURING ANY ORAL DISCUSSION HELD BETWEEN VENDOR'S REPRESENTATIVES AND ANY STATE PERSONNEL IS NOT BINDING. ONLY THE INFORMATION ISSUED IN WRITING AND ADDED TO THE SPECIFICATIONS BY AN OFFICIAL ADDENDUM IS BINDING.</p> <p>..... <i>[Signature]</i> SIGNATURE <i>Unisys Corporation</i> COMPANY <i>12/27/07</i> DATE</p> <p>REV. 11/96</p> <p>CONTRACTORS LICENSE</p> <p>WEST VIRGINIA STATE CODE 21-11-2 REQUIRES THAT ALL PERSONS DESIRING TO PERFORM CONTRACTING WORK IN THIS STATE MUST BE LICENSED. THE WEST VIRGINIA CONTRACTORS LICENSING BOARD IS EMPOWERED TO ISSUE THE CONTRACTORS LICENSE. APPLICATIONS FOR A CONTRACTORS LICENSE MAY BE MADE BY CONTACTING THE WEST VIRGINIA DIVISION OF LABOR CAPITOL COMPLEX, BUILDING 3, ROOM 319, CHARLESTON, WV 25305. TELEPHONE: (304) 558-7890.</p> <p>WEST VIRGINIA STATE CODE 21-11-11 REQUIRES ANY PROSPECTIVE BIDDER TO INCLUDE THE CONTRACTORS LICENSE NUMBER ON THEIR BID.</p>						

SEE REVERSE SIDE FOR TERMS AND CONDITIONS

SIGNATURE: <i>[Signature]</i>	TELEPHONE: <i>215 986 6614</i>	DATE: <i>12/27/07</i>
TITLE: <i>Contract Manager</i>	FEIN: <i>3803 87840</i>	ADDRESS CHANGES TO BE NOTED ABOVE

WHEN RESPONDING TO RFQ, INSERT NAME AND ADDRESS IN SPACE ABOVE LABELED 'VENDOR'



State of West Virginia
 Department of Administration
 Purchasing Division
 2019 Washington Street East
 Post Office Box 50130
 Charleston, WV 25305-0130

Request for Quotation

RFQ NUMBER
AUD083223

PAGE
9

ADDRESS CORRESPONDENCE TO ATTENTION OF
RON PRICE
304-558-0492

RFQ COPY

TYPE NAME/ADDRESS HERE

PROPERTY

Unisys Corporation
Unisys Way
Blue Bell, PA 19424

STATE

STATE AUDITOR'S OFFICE
 BUILDING 1, ROOM W100
 1900 KANAWHA BOULEVARD, EAST
 CHARLESTON, WV
 25305-0230 558-2251

DATE PRINTED	TERMS OF SALE	SHIP VIA	F.O.B.	FREIGHT TERMS
11/27/2007				

BID OPENING DATE: **12/19/2007** BID OPENING TIME **01:30PM**

LINE	QUANTITY	UOP	CAT NO	ITEM NUMBER	UNIT PRICE	AMOUNT
<p>BIDDER TO COMPLETE:</p> <p>CONTRACTORS NAME: <i>Unisys Corporation</i></p> <p>CONTRACTORS LICENSE NO.: <i>WV 014 839</i></p> <p>THE SUCCESSFUL BIDDER WILL BE REQUIRED TO FURNISH A COPY OF THEIR CONTRACTORS LICENSE PRIOR TO ISSUANCE OF A PURCHASE ORDER/CONTRACT</p> <p style="text-align: center;">APPLICABLE LAW</p> <p>THE WEST VIRGINIA STATE CODE, PURCHASING DIVISION RULES AND REGULATIONS, AND THE INFORMATION PROVIDED IN THE "REQUEST FOR QUOTATION" ISSUED BY THE PURCHASING DIVISION IS THE SOLE AUTHORITY GOVERNING THIS PROCUREMENT.</p> <p>ANY INFORMATION PROVIDED IN SPECIFICATION MANUALS, OR ANY OTHER SOURCE, VERBAL OR WRITTEN, WHICH CONTRADICTS OR ALTERS THE INFORMATION PROVIDED FROM THE SOURCES AS DESCRIBED IN THE ABOVE PARAGRAPH IS VOID AND OF NO EFFECT.</p> <p>BANKRUPTCY: IN THE EVENT THE VENDOR/CONTRACTOR FILES FOR BANKRUPTCY PROTECTION, THIS CONTRACT IS AUTOMATICALLY NULL AND VOID, AND IS TERMINATED WITHOUT FURTHER ORDER.</p> <p>REV. 1/2005</p> <p style="text-align: center;">NOTICE</p> <p>A SIGNED BID MUST BE SUBMITTED TO:</p>						

SEE REVERSE SIDE FOR TERMS AND CONDITIONS

SIGNATURE <i>[Signature]</i>	TELEPHONE <i>215 986 6164</i>	DATE <i>12/17/07</i>
TITLE <i>Contract Manager</i>	FEDIN <i>3803 87840</i>	ADDRESS CHANGES TO BE NOTED ABOVE

WHEN RESPONDING TO RFQ, INSERT NAME AND ADDRESS IN SPACE ABOVE LABELED 'VENDOR'



State of West Virginia
 Department of Administration
 Purchasing Division
 2019 Washington Street East
 Post Office Box 50130
 Charleston, WV 25305-0130

Request for Quotation

RFQ NUMBER
AUD083223

PAGE
10

ADDRESS CORRESPONDENCE TO ATTENTION OF
RON PRICE
304-558-0492

VENDOR

RFQ COPY
 TYPE NAME/ADDRESS HERE
Unisys Corporation
Unisys Way
Blue Bell PA 19424

SHIP TO

STATE AUDITOR'S OFFICE
 BUILDING 1, ROOM W100
 1900 KANAWHA BOULEVARD, EAST
 CHARLESTON, WV
 25305-0230 558-2251

DATE PRINTED	TERMS OF SALE	SHIP VIA	FOB	FREIGHT TERMS
11/27/2007				

BID OPENING DATE: **12/19/2007** BID OPENING TIME **01:30PM**

LINE	QUANTITY	UOP	CAT NO	ITEM NUMBER	UNIT PRICE	AMOUNT
DEPARTMENT OF ADMINISTRATION PURCHASING DIVISION BUILDING 15 2019 WASHINGTON STREET, EAST CHARLESTON, WV 25305-0130						
THE BID SHOULD CONTAIN THIS INFORMATION ON THE FACE OF THE ENVELOPE OR THE BID MAY NOT BE CONSIDERED:						
SEALED BID BUYER: RP-41 REQ. NO.: AUD083223 BID OPENING DATE AND TIME						
PLEASE PROVIDE A FAX NUMBER IN CASE IT IS NECESSARY TO CONTACT YOU REGARDING YOUR BID: ----- <i>518-452-6294 (fax)</i>						
PLEASE PRINT OR TYPE NAME OF PERSON TO CONTACT CONCERNING THIS QUOTE: ----- <i>Michael Kennedy</i> <i>518-452-6238 voice</i>						

SEE REVERSE SIDE FOR TERMS AND CONDITIONS

SIGNATURE <i>Rona (M) ...</i>	TELEPHONE	DATE <i>12/27/07</i>
TITLE <i>Contracts Manager</i>	FEIN <i>380387840</i>	ADDRESS CHANGES TO BE NOTED ABOVE

WHEN RESPONDING TO RFQ, INSERT NAME AND ADDRESS IN SPACE ABOVE LABELED 'VENDOR'



State of West Virginia
 Department of Administration
 Purchasing Division
 2019 Washington Street East
 Post Office Box 50130
 Charleston, WV 25305-0130

Request for Quotation

RFQ NUMBER:
AUD083223

PAGE:
11

ADDRESS CORRESPONDENCE TO ATTENTION OF:
RON PRICE
304-558-0492

RFQ COPY

TYPE NAME/ADDRESS HERE

Unisys Corporation
Unisys Way
Blue Bell PA 19424

SHIP TO

STATE AUDITOR'S OFFICE
 BUILDING 1, ROOM W100
 1900 KANAWHA BOULEVARD, EAST
 CHARLESTON, WV
 25305-0230 558-2251

DATE PRINTED	TERMS OF SALE	SHIP VIA	FOB	FREIGHT TERMS
11/27/2007				

BID OPENING DATE: **12/19/2007** BID OPENING TIME **01:30PM**

LINE	QUANTITY	UOP	CAT. NO.	ITEM NUMBER	UNIT PRICE	AMOUNT
***** THIS IS THE END OF RFQ AUD083223 ***** TOTAL: _____						

SEE REVERSE SIDE FOR TERMS AND CONDITIONS

SIGNATURE <i>Paula M...</i>	TELEPHONE <i>215 9866614</i>	DATE <i>12-27-07</i>
TITLE <i>Contract Manager</i>	FEIN <i>380387840</i>	ADDRESS CHANGES TO BE NOTED ABOVE

WHEN RESPONDING TO RFQ, INSERT NAME AND ADDRESS IN SPACE ABOVE LABELED 'VENDOR'

Request for Quote
AUD083223 WV State Auditor's Office

PART 1 GENERAL INFORMATION

Purpose:

The Acquisition and Contract Administration Section of the Purchasing Division, hereinafter referred to as "State", is soliciting quotes for the West Virginia State Auditor's Office, also referred to as "Agency" or WWSAO is soliciting a bids from qualified vendors for products and services for a full turnkey environmental solution to support both the facility and the data center located at 200 West Main Street Clarksburg, WV 26301.

Project:

Agency currently utilizes the existing HVAC to address environmental needs. As the Agency will be using this location for their Disaster Recovery (DR) Site upon completion of this project, improvements must be made before the equipment can be relocated to the Clarksburg site.

A mandatory prebid conference shall be conducted on the date and time specified. Said conference will be held at 200 W. Main Street, Clarksburg, WV. All interested bidders are required to be present at this meeting. Failure to attend the mandatory prebid conference shall automatically result in disqualification. No one person can represent more than one vendor.

PART 2 OPERATING ENVIRONMENT**Location:**

200 W. Main Street, Clarksburg, WV 26301

Background:

Agency currently has a data center located at the project address, but with minimum equipment maintained on site.

PART 3 PROCUREMENT SPECIFICATIONS**General Requirements:**

Major sections to this RFQ

HVAC: Provide and install/maintenance

UPS: Provide and install/maintenance

Additional Installation Hardware

Quote as per the following:

1. Heating, Ventilation, and Air Conditioning (HVAC) system shall provide cooling on a 24 hours-per-day, 365 days-per-year basis for the Clarksburg data center and contain a level of redundancy such that if one unit fails completely, the remaining unit has the capacity to keep the room cool to the required specification, 70 degrees F +/- 2 degrees and 50% +/-5% Relative Humidity (R/H).

a. The vendor will need to quote as per the following or equivalent. See attached specification sheet

2. Uninterruptible Power Supply (UPS) system that is rated at 40 KVA upgradeable to 80 KVA with enough battery back-up to support an outage of approximately one hour for the Clarksburg data Center.

a. The vendor shall affirm that the current raised floor will support the weight of the proposed unit and supply if necessary any support structure required.

b. The vendor will need to quote as per the following or equivalent. See attached specification sheet

3. The vendor will include the cost of all additional hardware that is required to successfully install the environmental system. This is to include but not limited to cables, wiring, connectors, plugs, transfer switch, etc.

4. The vendor will be responsible for the entire project from start to finish. This is to include but not limited to: Personnel that might be required to verify the power, structure, cooling, working with American Electric and Power (AEP) to ensure that there is adequate power supplying the facility, contractors, the building owner, local and state

municipalities, acquiring all permits and licenses that are required to complete the job successfully. Therefore: The vendor must include a detailed Scope of Work (SOW) for this installation and any associated cost.

5. The vendor must include a detailed listing and or narrative of the repair part supply/replacement infrastructure that is in place to guarantee timely supply of parts for ALL proposed hardware.

6. The vendor must quote monthly maintenance charges for seven days by twenty-four hours per day (7x24); five days by nine hours per day (5x9) maintenance service as separate items. The Auditor reserves the right to select the one most appropriate service to be included in the final contract pricing.

7. The vendor should indicate the time frame for the completed installation and full operational status required for the proposed installation. After the Receipt of Order (ARO). During our research it was determined some the equipment has extended lead times for delivery. Therefore, the successful vendor will need to provide a payment schedule accordingly.

8. The environmental system quoted must currently be manufactured (e.g. not discontinued or will be discontinued within the next 3 years).

9. The specific environment solution proposed by the vendor must be operating to the customer's satisfaction in three (3) user sites in the United States. Names and telephone numbers of the customer for reference purposes shall be included with the vendor proposal. In the event that any vendor does not have the exact system installed as proposed, the vendor shall provide the names and telephone numbers for reference of three (3) satisfied customers as reference of installation, by the proposing vendor, that have the same functionality and as similar to the same equipment as possible to the proposed equipment.

10. Final acceptance of the UPS equipment and installation is contingent upon a successful test of a power outage where the UPS system will supply the necessary power. Final acceptance of the HVAC equipment and installation is contingent upon a successful test of one AC unit being shut down and the other unit auto starting to take over the load in the data center.

See Chart below for possible equipment that will be placed at the Clarksburg Location:

Equipment	Power kW	Total Pwr kW	Plug type	BTUs	Total BTUs
Libra 580 MCP	0.79	1.58		5372	10744
ES7000/510	1.2	4.8		4000	16000
Dell 2850	0.7	4.9		2390.5	16733.5
CX300 1 ph	0.618	0.618		2000	2000
CX300-DAE disk array	0.392	0.392		1340	1340
Centera CNR40-PER	5.6	2.5	L6-30	1020	1020
Cisco9216A	0.845	1.69		2885.675	5771.35
Telcom/server rack	3.5	3.5		11952.5	11952.5
UHS5160	5.3	5.3		18099	18099
UMS2003	0.175	0.175		597.625	597.625
desktop laser	1	1		3415	3415
workstations	0.7	2.1		974	2922
racks from NW3C	2	6		6830	20490
		34.555			111085
UPS		36kW	(25kVA)		11800
lights	3 watts per sq ft	1248W			4243
people				?	?
Totals					127128
					10.594 tons

HVAC

15 Ton:

One (1) Liebert Model DH199A-CAEI, 208 Volts, 60Hz, 3 Phase Deluxe System/3
Environmental Control System: Nominal 15 ton Air Cooled Down flow System, MBH at 72°F,
 50% RH

One (1) 95°F Ambient Fan Speed Control Condenser Model DCDF205-Y, 208/230 Volts,
 60Hz, 3 Phases

- Includes Factory Wired Condenser Disconnect Switch
-

System Accessories:

- Advanced Microprocessor-Based Temperature and Humidity Controls
- Display Language is English
- Audible and Visual Alarms
- 3.0 HP Fan Motor
- Electric Reheat
- Infrared Humidifier
- Locking Disconnect Switch
- 4" – 20% Filter Package
- 12" High Floor stand
- Turning Vanes
- Qty-2 LT300 Point Leak Detection Sensor
- **Services Include:**
 - One year Parts only warranty

10 Ton:

One (1) Liebert Model DH125A-CAEI, 208 Volts, 60Hz, 3 Phase Deluxe System/3
Environmental Control System: Nominal 10 ton Air Cooled Down flow System, MBH at 72°F,
 50% RH

One (1) 95°F Ambient Fan Speed Control Condenser Model DCDF205-Y, 208/230 Volts,
 60Hz, 3 Phases

- Includes Factory Wired Condenser Disconnect Switch
-

System Accessories:

- Advanced Microprocessor-Based Temperature and Humidity Controls
- Display Language is English
- Audible and Visual Alarms
- 3.0 HP Fan Motor
- Electric Reheat
- Infrared Humidifier
- Locking Disconnect Switch
- 4" – 20% Filter Package
- 12" High Floor stand
- Turning Vanes
- Qty-2 LT300 Point Leak Detection Sensor
- **Services Include:**
 - One year Parts only warranty

UPS

- **Powerware 9390-80 40 kVA, On Line UPS, 40kVA/36kW. 208V in/out. Includes 3 breaker bypass sidecar cabinet.** Double Conversion Topology, Unit efficiency up to 94%, Unit output rating @ 0.9 Power Factor, Input current distortion < 4.5%, Patented ABM Technology, Patented HotSync parallel firmware control, Scalable Architecture, Parallel Redundancy and Capacity capable, Variable DC bus for optimizing battery runtime options.
Start-up: PLUS One year on-site parts & labor coverage (7x24),
UPS Cabinet Dimensions: 18.9"W x 31.6"D x 73.7"H
UPS Cabinet Weight: 640 lbs.

- **Battery Cabinet System, (1) IBC-L Integrated Battery Cabinet, 480 VDC. Back-up time @ 0.9pf (40 kVA/36kW) 59 minutes**

Battery Cabinet Dimensions: 42.7"W x 31.6"D x 73.7"H

19



associates. inc
architecture
planning

William E. Yoke, Jr. AIA

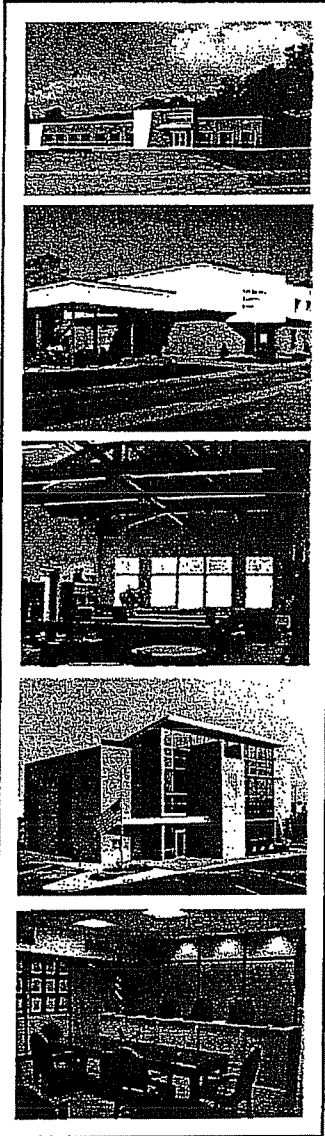

October 9, 2007

Kirk Rector
WV State Auditor's Office
1900 Kanawha Boulevard, East
Capitol Complex, Building 1, Suite W-100
Charleston, WV 25305

Re: Data Center for Northern WV Field Office

Dear Kirk:

In accordance with CMA Engineering's Revised Report of October 2, 2007, we have reviewed the structural capabilities of the existing building in regard to the placement of the emergency generator and the remote condensing units for the Liebert HVAC equipment.

The report provides detailed information on the required footprint size of the generator and its service clearance requirements. There is no place on the roofs of the existing building that will provide the area needed, and the existing structure will not accommodate the weight loads, operating vibration or start up movement. In addition, access for fueling and service is not feasible. As noted, in the report, the most logical locations for the generator are a structural platform constructed in the alley behind the building, or on grade on the adjoining property. Clearly, the on-grade location is preferable. I spoke to the City Manager regarding the ultimate use of the property, and he advised that the City would like to lease or purchase it for use as a parking lot and green space. I explained the need for and size requirements for the generator. We will follow up on this as the building comes down and the use of the site is determined.

Paragraph 4f. on the last page of the report requests confirmation that the roof structure will accommodate the loads from the remote condensing units for the Data Center HVAC equipment. We reviewed two potential locations for these condensing units – a low roof off of the third floor, and higher roof above the third floor. There is some abandoned equipment on the lower roof that should be removed, and in either case the units will need to be set on curbs or blocking to keep them level and get them up off of the roof surface. The existing structure of either roof will accept the weight of the units.

Please contact me if you have any questions or if we need to provide any additional information.

Sincerely,

WYK Associates, Inc.

William E. Yoke Jr., AIA

Copy: CMA Engineering, Inc.

POST OFFICE BOX1484
CLARKSBURG, W.V. 26301
205 WASHINGTON AVE.
(304) 624-6326
FAX: (304) 623-9858
EMAIL
wyk@wykarchitects.com



associates. inc
architecture
planning

William E. Yoke, Jr. AIA

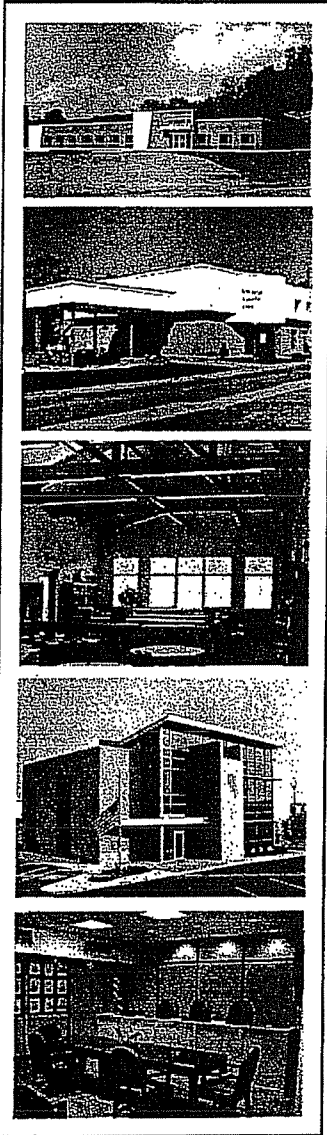

September 27, 2007

Kirk Rector
WV State Auditor's Office
1900 Kanawha Boulevard, East
Capitol Complex, Building 1, Suite W-100
Charleston, WV 25305

Re: Data Center for Northern WV Field Office

Dear Kirk:

Please find attached the revised report from CMA Engineering evaluating the equipment and electrical service for the proposed upgrade of the data center in Clarksburg. The revised report reflects additional information gathered from your office, Tim Sharpe of William R. Sharpe Electric and Penny Baldwin of Allegheny Power Co. As the report indicates, and, as we have discussed, there are still some outstanding issues in regard to the location of the emergency generator and power company access to transformers and electrical service entrances at both 200 W. Main Street and the adjoining building on 2nd Street.

We believe the report meets the requirements for Phase 1 of our scope of work. We are prepared to answer any additional questions that you may have, and will continue to seek answers from the various parties regarding the options for placing the generator and the required modifications to the electrical service. We are available to meet at the site to confirm any additional requirements for the installation of the equipment, location of the generator or the service upgrade.

Please contact me if you have any questions or if we need to provide any additional information.

Sincerely,

WYK Associates, Inc.

William E. Yoke, Jr.
William E. Yoke, Jr., AIA

Copy: CMA Engineering, Inc.

POST OFFICE BOX1484
CLARKSBURG, W.V. 26301
205 WASHINGTON AVE.
(304) 624-6326
FAX: (304) 623-9858
EMAIL
wyk@wykarchitects.com



October 2, 2007

Mr. Bill Yoke, A.I.A.
 WYK Associates, Inc.
 205 Washington Avenue
 Clarksburg, WV 26301

Subject: WVSAO Clarksburg Data Center Review
 Phase 1 & Phase 2 Scope of Work
Revised

Dear Mr. Yoke,

This letter is a revision of our earlier summary. The earlier report was based on the understanding that both of the new HVAC units would be required to operate together on emergency power. Afterward, it was clarified that the smaller (10-ton) HVAC unit would only be in operation when the larger (15-ton) unit was not available. Therefore another generator loading simulation was made without the need to serve the smaller HVAC unit. The following is our revised summary based on this corrected information.

CMA Engineering Inc. (CMA) has completed their review of the HVAC and Electrical Equipment List in comparison with the New Data Center Layout and Equipment List as furnished by the Owner. We have the following observations to note for the Owner:

HVAC Equipment:

1. The proposed two Liebert Units and their associated remote condensing units specified appear to meet the heating and cooling loads as scheduled by the Owner for this new space layout. One item we would recommend be added to this specification would be cylinder unloaders and associated controls for each compressor on each of the two units (to allow the machines to have some step control to match the space cooling load requirements). Liebert's "Site Scan" controls systems are recommended for each unit. This feature will allow a systematic stepping of startups for individual components to minimize engine/generator set size due to startup surges. It is understood that only one of the two HVAC units will be in operation at any time and that, typically, the larger (15-ton) unit will be serving the center. The smaller (10-ton) unit will operate only when the larger unit is unavailable due to maintenance or other reasons. Therefore, provisions must be made, either with the HVAC controls systems (Liebert's "Site Scan" or equivalent) or by other means to ensure that both units are not operated together when emergency power is in service supplied by the engine / generator set.

Charleston
 824 Cross Lanes Drive
 Charleston, West Virginia 25313
 (304) 343-0316 tel
 (304) 343-5146 fax

Morgantown
 5 Riddle Court
 Morgantown, West Virginia 26505
 (304) 598-2558 tel
 (304) 598-2472 fax

Clingenpeel/McBrayer & Associates, Inc.

www.cma.wv.com

UPS Equipment:

2. The 36 KW / 40 KVA uninterruptible power service (UPS) seems adequately sized to handle the loads indicated (34.6 KW). A 12-pulse rectifier-switching circuit or equivalent enhanced controls in the rectifier section are also recommended to reduce generator alternator size.

Emergency Generator Equipment:

3. After running a number of simulations of the existing and new equipment to be served by this system we feel this engine / generator set may be sized from a minimum of 150 KW (to cover only proposed loads for the data center) and could require a sizing of up to 230 KW (if additional building loads are required per the existing building distribution system reviewed) and provided with the following options to allow a staggered start of associated equipment through the ATS and other associated controls:
 - a. Liebert's "Site Scan" controls systems are recommended for each Liebert HVAC unit (as detailed in Item #1 above).
 - b. A general service upgrade consisting of a 1,200 amp main distribution panel and an 800-amp automatic transfer switch that would serve the existing 600 amp panelboard plus a new 800-amp emergency distribution panel. Ground-fault interruption (GFI) protection will not be required for the emergency power panelboard. The new emergency distribution panel would serve all of the needs of the new data center including the two (2) new HVAC units, the UPS and the existing 100 amp panel "A". As stated before, provisions will have to be made by the HVAC controls systems (or by other means) to ensure that both units are not started when running on emergency power.

Automatic Transfer Switch (ATS) Equipment:

4. This ATS must be changed to suit the revised sizing of equipment noted in item 3 above to be at least 800-amp capacity, rated for exterior applications (NEMA 3R rating).

See the attached riser diagram of the proposed service upgrade and new equipment.

In addition to reviewing this proposed HVAC and Electrical equipment versus the data center equipment list we wish to note the following major concerns which we feel must be addressed during a design effort to allow this project to be completed successfully. This design effort is outside the scope of our services, but we feel it is critical for us to note these issues to the Owner in order to ensure there are no design assumptions made. We feel a complete engineering design with detailed construction documents should be completed prior to ordering this equipment to ensure all of the proposed equipment and systems will adequately fit in the tight confines of the existing alley and lower level electrical entrance space.

1. The existing building that houses the new Data Center has two electrical entrances. The electrical entrance which must be upgraded to serve the new emergency generator, ATS, associated emergency loads, and the existing 600-amp, 120/208-volt, 3-phase service presently feeds into the basement area through a power company current transformer box and into the existing 600 amp service panelboard. We feel this service must be changed out to approximately a 1,200-amp (maximum) service with a new 1,200-amp panelboard and then to back-feed the existing 600 amp service in the basement. There is currently no location that we can foresee in the basement which will allow this installation which only leaves an exterior installation for the panelboard, ATS, CT cabinet, etc. This will require exterior rated equipment which has not been specified at this point.
2. The only location we can possibly foresee which will work for installation of the new emergency engine/generator set is outside the building on grade in the alley. However, this may even prove unacceptable. The alley is reported to be only 9 feet, 9 inches wide. If the equipment could be located there, then some security measures to isolate this equipment from the public are also required to still provide emergency egress from the adjacent buildings if required by the Local Fire Department.
3. The exterior location of this emergency engine/generator set will require a screened enclosure and the required air flow clearances per the manufacturer's recommendations to allow proper heat transfer and maintenance. A sound attenuated enclosure may also be needed to reduce noise to the data center and to the adjacent properties. Rough sizing of a 230KW engine / generator set with a weatherproof enclosure and a 336 gallon fuel tank (for 18 hours of operation) is 40 inches wide by 106 inches high by 105 inches long and requires 36 inches clear space on each side and 36 inches clear space on each end for maintenance access. If a sound-attenuated enclosure is required, then the length increases to 142 inches. The other dimensions stay the same. Rough sizing of a 150 KW engine / generator set is the same as for the 230 KW set. Height of the equipment varies depending on storage size, typically 106 inches or slightly taller. The 36 inch clearance for maintenance access remains the same. The manufacturer's minimum maintenance and operational clearances must be maintained on all sides for service / repair access and for proper airflow. This equates to a total footprint, including maintenance access (for door swings) of 177 inches by 112 inches for either the 150 KW or the 230 KW sets. The footprint grows to 214 inches by 112 inches for both sets, if sound-attenuation is required. Review of these actual dimensions for operation and maintenance must be completed prior to ordering material for this installation. This smaller range of equipment with a width footprint of 112 inches (9 feet, 4 inches) may make location of this equipment in the alley (at 9 feet, 9 inches wide) a possibility. However, there would be no fire escape / egress access through that area and the equipment may have to be installed on an elevated structural platform to allow maintenance access to the

pad-mounted transformers also located in that alley. In conversations with the end user of the facility, it has been learned that it may be possible to locate the emergency engine / generator set on adjacent property that is being cleared for a parking lot. However, this will need to be further reviewed during preparation of construction documents.

4. We would also recommend the following general space construction modifications:
 - a. Clean and seal the under-floor area of the clean room (below the raised floor which will be used as a supply plenum for the new HVAC units).
 - b. Ensure that all of the cabling in this under-floor area is either in conduit or plenum rated.
 - c. Remove or seal off supply or return ducts from other HVAC systems now crossing over the new Data Center Space. Re-insulate any supply duct to ensure no condensation occurs above the ceiling.
 - d. Consider closing off and sealing the walls to bottom of the floor structure above the new Data Center to prevent air from other areas of the building from entering this space. This also will help for any potential security concerns of this space.
 - e. Provide fire alarm system detection for the under-floor area and above ceiling area for the new Data Center and connect to the building fire alarm system since the space is not currently served by a fire sprinkler system.
 - f. Verify existing structure capabilities to locate the new remote condensing units on the roof. Routing of the new refrigerant piping and power to these units must be done through chases which are sealed off to meet the required fire rating separation in the facility.
 - g. Provide new condensate drain piping and routing to adequate floor drains in the facility to serve the new Data Center HVAC units.
 - h. We also would recommend some form of under-floor moisture sensor and an alarm to prevent potential damage due to piping leaks or condensation build up since this space is also used as a wiring path.

Please feel free to contact me at your convenience if you have any questions or concerns with this information.

Sincerely,
CMA Engineering, Inc.

Timothy L. Cox, P.E.
President
TLC

Cc: Dan Ellars, P.E.

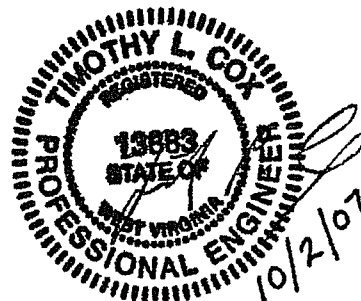

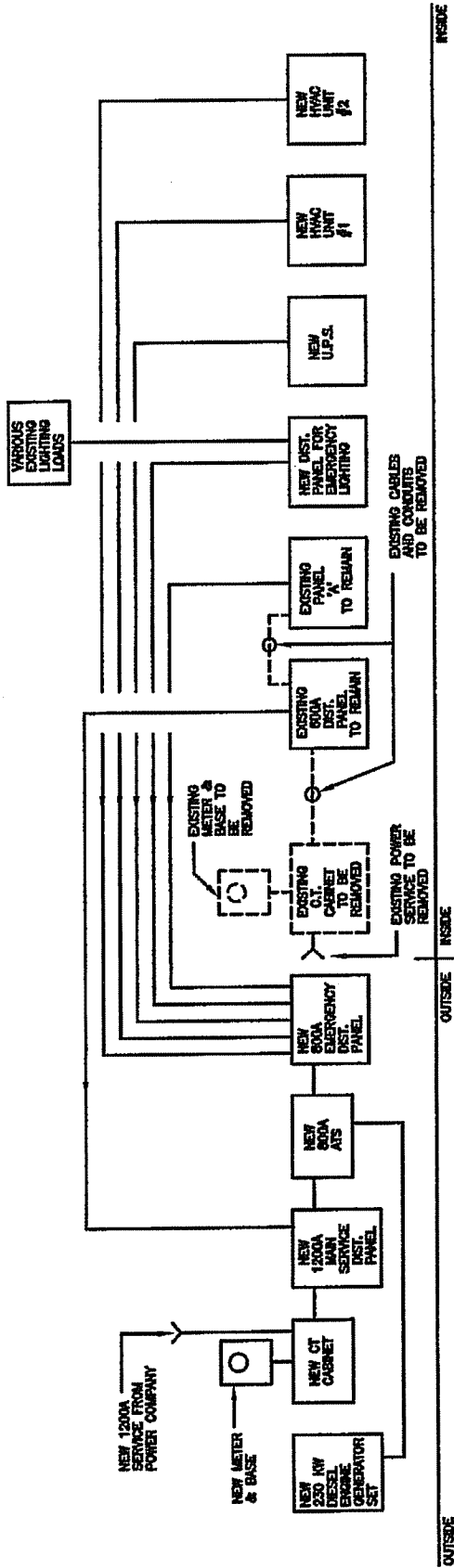

ELECTRICAL RISER
NOT TO SCALE

STATE OF WEST VIRGINIA
Purchasing Division

PURCHASING AFFIDAVIT

West Virginia Code §5A-3-10a states: No contract or renewal of any contract may be awarded by the state or any of its political subdivisions to any vendor or prospective vendor when the vendor or prospective vendor or a related party to the vendor or prospective vendor is a debtor and the debt owed is an amount greater than one thousand dollars in the aggregate

DEFINITIONS:

"Debt" means any assessment, premium, penalty, fine, tax or other amount of money owed to the state or any of its political subdivisions because of a judgment, fine, permit violation, license assessment, defaulted workers' compensation premium, penalty or other assessment presently delinquent or due and required to be paid to the state or any of its political subdivisions, including any interest or additional penalties accrued thereon.

"Debtor" means any individual, corporation, partnership, association, limited liability company or any other form or business association owing a debt to the state or any of its political subdivisions. "Political subdivision" means any county commission; municipality; county board of education; any instrumentality established by a county or municipality; any separate corporation or instrumentality established by one or more counties or municipalities, as permitted by law; or any public body charged by law with the performance of a government function or whose jurisdiction is coextensive with one or more counties or municipalities. "Related party" means a party, whether an individual, corporation, partnership, association, limited liability company or any other form or business association or other entity whatsoever, related to any vendor by blood, marriage, ownership or contract through which the party has a relationship of ownership or other interest with the vendor so that the party will actually or by effect receive or control a portion of the benefit, profit or other consideration from performance of a vendor contract with the party receiving an amount that meets or exceed five percent of the total contract amount.

EXCEPTION: The prohibition of this section does not apply where a vendor has contested any tax administered pursuant to chapter eleven of this code, workers' compensation premium, permit fee or environmental fee or assessment and the matter has not become final or where the vendor has entered into a payment plan or agreement and the vendor is not in default of any of the provisions of such plan or agreement.

LICENSING: Vendors must be licensed and in good standing in accordance with any and all state and local laws and requirements by any state or local agency of West Virginia, including, but not limited to, the West Virginia Secretary of State's Office, the West Virginia Tax Department, West Virginia Insurance Commission, or any other state agencies or political subdivision. Furthermore, the vendor must provide all necessary releases to obtain information to enable the Director or spending unit to verify that the vendor is licensed and in good standing with the above entities.

CONFIDENTIALITY: The vendor agrees that he or she will not disclose to anyone, directly or indirectly, any such personally identifiable information or other confidential information gained from the agency, unless the individual who is the subject of the information consents to the disclosure in writing or the disclosure is made pursuant to the agency's policies, procedures and rules. Vendors should visit www.state.wv.us/admin/purchase/privacy for the Notice of Agency Confidentiality Policies.

Under penalty of law for false swearing (West Virginia Code, §61-5-3), it is hereby certified that the vendor acknowledges the information in this said affidavit and are in compliance with the requirements as stated. *to the best of my knowledge + belief*

Vendor's Name: Unisys Corporation

Authorized Signature: [Signature] Date: 10-27-07



State of West Virginia
 Department of Administration
 Purchasing Division
 2019 Washington Street East
 Post Office Box 50130
 Charleston, WV 25305-0130

Request for Quotation

RFQ NUMBER
 AUD083223

PAGE
 1

ADDRESS CORRESPONDENCE TO ATTENTION OF:
 RON PRICE
 304-558-0492

RFQ COPY

TYPE NAME/ADDRESS HERE

VENDOR

Unisys Corporation
 Unisys Way
 Blue Bell PA 19424

SHIP TO

STATE AUDITOR'S OFFICE
 BUILDING 1, ROOM W100
 1900 KANAWHA BOULEVARD, EAST
 CHARLESTON, WV
 25305-0230 558-2251

DATE PRINTED	TERMS OF SALE	SHIP VIA	FOB	FREIGHT TERMS
12/06/2007				

BID OPENING DATE: 12/19/2007 BID OPENING TIME 01:30PM

LINE	QUANTITY	UOP	CAT NO	ITEM NUMBER	UNIT PRICE	AMOUNT
0001	1	LS		031-06		
ADDENDUM NO. 1 ATTACHED IS THE SIGN-IN SHEET FOR THE PRE-BID OF DECEMBER 5, 2007. POTENTIAL BIDDERS ARE TO CONTACT 304-527-2415 TO SCHEDULE A SITE VISIT TO COMPLETE THE INSPECTION AND TO COLLECT ANY NECESSARY MEASUREMENTS. HVAC/UPS SYSTEM						
***** THIS IS THE END OF RFQ AUD083223 ***** TOTAL:						

SEE REVERSE SIDE FOR TERMS AND CONDITIONS

SIGNATURE *[Signature]* TELEPHONE 2159866614 DATE 12/27/07
 TITLE Contract Manager FEIN 380387840 ADDRESS CHANGES TO BE NOTED ABOVE

WHEN RESPONDING TO RFQ, INSERT NAME AND ADDRESS IN SPACE ABOVE LABELED 'VENDOR'

**GENERAL TERMS & CONDITIONS
REQUEST FOR QUOTATION (RFQ) AND REQUEST FOR PROPOSAL (RFP)**

1. Awards will be made in the best interest of the State of West Virginia.
2. The State may accept or reject in part, or in whole, any bid.
3. All quotations are governed by the *West Virginia Code* and the *Legislative Rules* of the Purchasing Division.
4. Prior to any award, the apparent successful vendor must be properly registered with the Purchasing Division and have paid the required \$125.00 registration fee.
5. All services performed or goods delivered under State Purchase Orders/Contracts are to be continued for the term of the Purchase Order/Contract, contingent upon funds being appropriated by the Legislature or otherwise being made available. In the event funds are not appropriated or otherwise available for these services or goods, this Purchase Order/Contract becomes void and of no effect after June 30.
6. Payment may only be made after the delivery and acceptance of goods or services.
7. Interest may be paid for late payment in accordance with the *West Virginia Code*.
8. Vendor preference will be granted upon written request in accordance with the *West Virginia Code*.
9. The State of West Virginia is exempt from federal and state taxes and will not pay or reimburse such taxes.
10. The Director of Purchasing may cancel any Purchase Order/Contract upon 30 days written notice to the seller.
11. The laws of the State of West Virginia and the *Legislative Rules* of the Purchasing Division shall govern all rights and duties under the Contract, including without limitation the validity of this Purchase Order/Contract.
12. Any reference to automatic renewal is hereby deleted. The Contract may be renewed only upon mutual written agreement of the parties.
13. **BANKRUPTCY:** In the event the vendor/contractor files for bankruptcy protection, this Contract may be deemed null and void, and terminated without further order.
14. **HIPAA Business Associate Addendum -** The West Virginia State Government HIPAA Business Associate Addendum (BAA), approved by the Attorney General, and available online at the Purchasing Division's web site (<http://www.state.wv.us/admin/purchase/vrc/hipaa.htm>) is hereby made part of the agreement. Provided that, the Agency meets the definition of a Covered Entity (45 CFR §160.103) and will be disclosing Protected Health Information (45 CFR §160.103) to the vendor.

INSTRUCTIONS TO BIDDERS

1. Use the quotation forms provided by the Purchasing Division.
2. **SPECIFICATIONS:** Items offered must be in compliance with the specifications. Any deviation from the specifications must be clearly indicated by the bidder. Alternates offered by the bidder as **EQUAL** to the specifications must be clearly defined. A bidder offering an alternate should attach complete specifications and literature to the bid. The Purchasing Division may waive minor deviations to specifications.
3. Complete all sections of the quotation form.
4. Unit prices shall prevail in cases of discrepancy.
5. All quotations are considered F.O.B. destination unless alternate shipping terms are clearly identified in the quotation.
6. **BID SUBMISSION:** All quotations must be delivered by the bidder to the office listed below prior to the date and time of the bid opening. Failure of the bidder to deliver the quotations on time will result in bid disqualifications.

SIGNED BID TO:

Department of Administration
Purchasing Division
2019 Washington Street East
Post Office Box 50130
Charleston, WV 25305-0130

Date: _____

SIGN IN SHEET

Request for Proposal No. **AU083223** PLEASE PRINT

* PLEASE BE SURE TO PRINT LEGIBLY - IF POSSIBLE, LEAVE A BUSINESS CARD

FIRM & REPRESENTATIVE NAME	MAILING ADDRESS	TELEPHONE & FAX NUMBERS
Company: <u>Casto Technical Services</u>	<u>546 Leon Sullivan Way</u>	PHONE <u>304-346-0599</u>
Rep: <u>Barry Justice</u>	<u>Charleston WV 25322</u>	TOLL FREE <u>800-232-2221</u>
Email Address: <u>bjustice@castotech.com</u>		FAX <u>304-346-8920</u>
Company: <u>Master Service Mid-Atlantic</u>	<u>P.O. Box 2417</u>	PHONE <u>304-636-8170</u>
Rep: <u>Byron Totten</u>	<u>Elkins WV 26241</u>	TOLL FREE
Email Address: _____		FAX <u>304-636-8206</u>
Company: <u>MR KANE CO</u>	<u>P.O. BOX 8236</u>	PHONE <u>304-624-7155</u>
Rep: <u>Patrick Calland</u>	<u>Nutterport 26301</u>	TOLL FREE
Email Address: <u>mr.kane@kane.com</u>		FAX <u>304 624 7182</u>
Company: <u>UNISYS CORP</u>	<u>158 W. 7TH AVE.</u>	PHONE <u>484-436-1181</u>
Rep: <u>ED KANE</u>	<u>TRAFFIC, PA 19426</u>	TOLL FREE
Email Address: <u>Ed.KANE@unisys.com</u>		FAX <u>215-986-7271</u>
Company: <u>BARNES AND BRASS ELECTRIC</u>	<u>PO Box 1956</u>	PHONE <u>304-624-7551</u>
Rep: <u>JASON TOMARO</u>	<u>CLARKSBURG WV 26302</u>	TOLL FREE <u>NA</u>
Email Address: <u>TOMAROJ@ELECTRICALSYSTEMS.COM</u>		FAX <u>304-624-5421</u>

Date: _____

SIGN IN SHEET

Request for Proposal No.

PLEASE PRINT

* PLEASE BE SURE TO PRINT LEGIBLY - IF POSSIBLE, LEAVE A BUSINESS CARD

FIRM & REPRESENTATIVE NAME	MAILING ADDRESS	TELEPHONE & FAX NUMBERS
Company: <u>BARNES & BRASS Electric</u>	<u>Po Box 1956</u>	PHONE <u>304-624-7551</u>
Rep: <u>Miko Smalley</u>	<u>Clarksburg</u>	TOLL FREE
Email Address: _____		FAX <u>304-624-6401</u>
Company: <u>Tri-State Roofing & Sheet Metal Co.</u>	<u>PO Box 392</u>	PHONE <u>304-328-5244</u>
Rep: <u>Dan Weitz</u>	<u>Morgantown WV</u>	TOLL FREE
Email Address: <u>Morgantown@tri-stateservice.com</u>	<u>26507</u>	FAX <u>304-328-5248</u>
Company: <u>Unisys</u>	<u>P.O. Box 2349</u>	PHONE <u>304-545-0794</u>
Rep: <u>Dave Williams</u>	<u>Charleston WV</u>	TOLL FREE
Email Address: <u>David.h.williams@unisys.com</u>	<u>25328</u>	FAX <u>215-986-9235</u>
Company: _____		PHONE
Rep: _____		TOLL FREE
Email Address: _____		FAX
Company: _____		PHONE
Rep: _____		TOLL FREE
Email Address: _____		FAX



State of West Virginia
 Department of Administration
 Purchasing Division
 2019 Washington Street East
 Post Office Box 50130
 Charleston, WV 25305-0130

Request for Quotation

RFQ NUMBER
 AUD083223

PAGE
 1

ADDRESS CORRESPONDENCE TO ATTENTION OF
 RON PRICE
 304-558-0492

VENDOR

RFQ COPY
 TYPE NAME/ADDRESS HERE
 Unisys Corporation
 Unisys Way
 BlueBell PA 19424

SHIP TO

STATE AUDITOR'S OFFICE
 BUILDING 1, ROOM W100
 1900 KANAWHA BOULEVARD, EAST
 CHARLESTON, WV
 25305-0230 558-2251

DATE PRINTED	TERMS OF SALE	SHIP VIA	F.O.B.	FREIGHT TERMS
12/12/2007				

BID OPENING DATE: 12/19/2007 BID OPENING TIME 01:30PM

LINE	QUANTITY	UOP	CAT NO	ITEM NUMBER	UNIT PRICE	AMOUNT
0001	1	LS		031-06		
ADDENDUM NO. 2 RESPONSES TO QUESTIONS RECEIVED BY THE 12/7/07 DEADLINE ARE ATTACHED HVAC/UPS SYSTEM ***** THIS IS THE END OF RFQ AUD083223 ***** TOTAL:						

SEE REVERSE SIDE FOR TERMS AND CONDITIONS

SIGNATURE: *[Signature]* TELEPHONE: 259866614 DATE: 12/19/07
 TITLE: Contract Manager FEIN: 350387840 ADDRESS CHANGES TO BE NOTED ABOVE

WHEN RESPONDING TO RFQ, INSERT NAME AND ADDRESS IN SPACE ABOVE LABELED 'VENDOR'

**GENERAL TERMS & CONDITIONS
REQUEST FOR QUOTATION (RFQ) AND REQUEST FOR PROPOSAL (RFP)**

1. Awards will be made in the best interest of the State of West Virginia.
2. The State may accept or reject in part, or in whole, any bid.
3. All quotations are governed by the *West Virginia Code* and the *Legislative Rules* of the Purchasing Division.
4. Prior to any award, the apparent successful vendor must be properly registered with the Purchasing Division and have paid the required \$125.00 registration fee.
5. All services performed or goods delivered under State Purchase Orders/Contracts are to be continued for the term of the Purchase Order/Contract, contingent upon funds being appropriated by the Legislature or otherwise being made available. In the event funds are not appropriated or otherwise available for these services or goods, this Purchase Order/Contract becomes void and of no effect after June 30.
6. Payment may only be made after the delivery and acceptance of goods or services.
7. Interest may be paid for late payment in accordance with the *West Virginia Code*.
8. Vendor preference will be granted upon written request in accordance with the *West Virginia Code*.
9. The State of West Virginia is exempt from federal and state taxes and will not pay or reimburse such taxes.
10. The Director of Purchasing may cancel any Purchase Order/Contract upon 30 days written notice to the seller.
11. The laws of the State of West Virginia and the *Legislative Rules* of the Purchasing Division shall govern all rights and duties under the Contract, including without limitation the validity of this Purchase Order/Contract.
12. Any reference to automatic renewal is hereby deleted. The Contract may be renewed only upon mutual written agreement of the parties.
13. **BANKRUPTCY:** In the event the vendor/contractor files for bankruptcy protection, this Contract may be deemed null and void, and terminated without further order.
14. **HIPAA Business Associate Addendum -** The West Virginia State Government HIPAA Business Associate Addendum (BAA), approved by the Attorney General, and available online at the Purchasing Division's web site (<http://www.state.wv.us/admin/purchase/vrc/hipaa.htm>) is hereby made part of the agreement. Provided that, the Agency meets the definition of a Covered Entity (45 CFR §160.103) and will be disclosing Protected Health Information (45 CFR §160.103) to the vendor.

INSTRUCTIONS TO BIDDERS

1. Use the quotation forms provided by the Purchasing Division.
2. **SPECIFICATIONS:** Items offered must be in compliance with the specifications. Any deviation from the specifications must be clearly indicated by the bidder. Alternates offered by the bidder as **EQUAL** to the specifications must be clearly defined. A bidder offering an alternate should attach complete specifications and literature to the bid. The Purchasing Division may waive minor deviations to specifications.
3. Complete all sections of the quotation form.
4. Unit prices shall prevail in cases of discrepancy.
5. All quotations are considered F.O.B. destination unless alternate shipping terms are clearly identified in the quotation.
6. **BID SUBMISSION:** All quotations must be delivered by the bidder to the office listed below prior to the date and time of the bid opening. Failure of the bidder to deliver the quotations on time will result in bid disqualifications.

SIGNED BID TO:

Department of Administration
Purchasing Division
2019 Washington Street East
Post Office Box 50130
Charleston, WV 25305-0130

**AUD083223 WWSAO HVAC/UPS CLARKSBURG DATACENTER
ADDENDUM #2**

1. What is the type of roof membrane and construction for the higher roof level?

Answer: Rubber - EPDM

2. Who is responsible for power supply to HVAC units in the computer room and power supply to the root top condensing units?

Answer: Building owner and their subcontractor

3. Who is responsible for power supply to UPS?

Answer: Building owner and their subcontractor

4. Will we be using existing panel box (s) or supplying new one?

Answer: New - Building owner and their subcontractor will be responsible

5. Can Bidders assume that the electrical distribution panel for connections for all new equipment will be located in the confines of the Computer Room?

Answer: Yes

6. Can the Agency confirm the preferred location of the outside condensing units?

Answer: Lower roof (as confirmed by the architect engineer William Yoke WYK). Therefore, it will be the responsibility of the winning vendor to remove the existing abandoned equipment there. Ref page #19 paragraph 4f and page #13 item 4.

7. Can the Agency confirm that the water and drainage hook-ups are accessible from the basement directly under the floor of the Computer Room?

Answer:

8. Can the Agency confirm that the Maintenance agreement will be a 1 year price, renewable for 2 additional years, and that the coverage is for labor only under a 7/24 or a 5/9 type agreement. Parts under this agreement not covered by warranty would be billable.

Answer: Maintenance will be one year with two one-year renewal options paid quarterly in arrears. All parts should be covered under warranty and maintenance periods unless it is a consumable item.

9. Will electrical power be supplied to Data Center by others for connection of the CRAC units and UPS?

Answer: Yes - Building owner and their subcontractor

a. If answer to above is yes, will a power distribution panel be installed in the data center? Please give a detailed description of the attributes of the panel.

Answer: Ref page #13 item 4.

10. Can windows and door opening be removed & reinstalled to accommodate moving equipment into place?

Answer: Ref page #13 item 4

11. Can refrigerant and electrical piping and conduit be installed thru the interior of the building or on the exterior (on alley side of building) at the discretion of the contractor?
Answer: Interior (as confirmed by the architect engineer William Yoke WYK) Ref page #13 item 4.

12. Can condensers be installed on the upper or lower roof at discretion of the contractor?

Answer: See question # 6

13. Can we have a copy of the sign in sheet for the pre-bid conference held on December 5, 2007?

Answer: Provided via Addendum #1

14. Should the UPS be wired for maximum capacity (80 KVA) to accommodate a potential future upgrade?

Answer: Yes

15. Will the floor in the entrance way and hallways support the equipment during moving?

Answer: Yes - (as confirmed by the architect engineer William Yoke WYK). Ref page #13 item 4

16. Will the building floor under the access flooring support the equipment in the data center?

Answer: Yes - (as confirmed by the architect engineer William Yoke WYK). Ref page #13 item 4

17. What do you expect will be the normal working hours for this project?

Answer: M-F 0700-1700



State of West Virginia
 Department of Administration
 Purchasing Division
 2019 Washington Street East
 Post Office Box 50130
 Charleston, WV 25305-0130

Request for Quotation

RFQ NUMBER
 AUD083223

PAGE
 1

ADDRESS CORRESPONDENCE TO ATTENTION OF
 RON PRICE
 304-558-0492

RFQ COPY

TYPE NAME/ADDRESS HERE

VENDOR

*Unisys Corporation
 Unisys Way
 Bluebell PA 19424*

SHIP TO

STATE AUDITOR'S OFFICE
 BUILDING 1, ROOM W100
 1900 KANAWHA BOULEVARD, EAST
 CHARLESTON, WV
 25305-0230 558-2251

DATE PRINTED 12/17/2007	TERMS OF SALE	SHIP VIA	F.O.B.	FREIGHT TERMS
BID OPENING DATE: 12/28/2007		BID OPENING TIME 01:30PM		

LINE	QUANTITY	UOP	CAT NO	ITEM NUMBER	UNIT PRICE	AMOUNT
ADDENDUM NO. 3						
BID OPENING DATE AND TIME CHANGED						
FROM: 12/19/07 AT 1:30 P.M.						
TO: 12/28/07 AT 1:30 P.M.						
NO OTHER CHANGES						
0001	1	LS		031-06		
HVAC/UPS SYSTEM						
***** THIS IS THE END OF RFQ AUD083223 ***** TOTAL:						

SEE REVERSE SIDE FOR TERMS AND CONDITIONS

SIGNATURE: *[Signature]* TELEPHONE: 2159866614 DATE: 12-27-07
 TITLE: Contracts Mgr FEIN: 3803 87840 ADDRESS CHANGES TO BE NOTED ABOVE

WHEN RESPONDING TO RFQ, INSERT NAME AND ADDRESS IN SPACE ABOVE LABELED 'VENDOR'

**GENERAL TERMS & CONDITIONS
REQUEST FOR QUOTATION (RFQ) AND REQUEST FOR PROPOSAL (RFP)**

1. Awards will be made in the best interest of the State of West Virginia.
2. The State may accept or reject in part, or in whole, any bid.
3. All quotations are governed by the *West Virginia Code* and the *Legislative Rules* of the Purchasing Division.
4. Prior to any award, the apparent successful vendor must be properly registered with the Purchasing Division and have paid the required \$125.00 registration fee.
5. All services performed or goods delivered under State Purchase Orders/Contracts are to be continued for the term of the Purchase Order/Contract, contingent upon funds being appropriated by the Legislature or otherwise being made available. In the event funds are not appropriated or otherwise available for these services or goods, this Purchase Order/Contract becomes void and of no effect after June 30.
6. Payment may only be made after the delivery and acceptance of goods or services.
7. Interest may be paid for late payment in accordance with the *West Virginia Code*.
8. Vendor preference will be granted upon written request in accordance with the *West Virginia Code*.
9. The State of West Virginia is exempt from federal and state taxes and will not pay or reimburse such taxes.
10. The Director of Purchasing may cancel any Purchase Order/Contract upon 30 days written notice to the seller.
11. The laws of the State of West Virginia and the *Legislative Rules* of the Purchasing Division shall govern all rights and duties under the Contract, including without limitation the validity of this Purchase Order/Contract.
12. Any reference to automatic renewal is hereby deleted. The Contract may be renewed only upon mutual written agreement of the parties.
13. **BANKRUPTCY:** In the event the vendor/contractor files for bankruptcy protection, this Contract may be deemed null and void, and terminated without further order.
14. **HIPAA Business Associate Addendum** - The West Virginia State Government HIPAA Business Associate Addendum (BAA), approved by the Attorney General, and available online at the Purchasing Division's web site (<http://www.state.wv.us/admin/purchase/vrc/hipaa.htm>) is hereby made part of the agreement. Provided that, the Agency meets the definition of a Covered Entity (45 CFR §160.103) and will be disclosing Protected Health Information (45 CFR §160.103) to the vendor.

INSTRUCTIONS TO BIDDERS

1. Use the quotation forms provided by the Purchasing Division.
2. **SPECIFICATIONS:** Items offered must be in compliance with the specifications. Any deviation from the specifications must be clearly indicated by the bidder. Alternates offered by the bidder as **EQUAL** to the specifications must be clearly defined. A bidder offering an alternate should attach complete specifications and literature to the bid. The Purchasing Division may waive minor deviations to specifications.
3. Complete all sections of the quotation form.
4. Unit prices shall prevail in cases of discrepancy.
5. All quotations are considered F.O.B. destination unless alternate shipping terms are clearly identified in the quotation.
6. **BID SUBMISSION:** All quotations must be delivered by the bidder to the office listed below prior to the date and time of the bid opening. Failure of the bidder to deliver the quotations on time will result in bid disqualifications.

SIGNED BID TO:

Department of Administration
Purchasing Division
2019 Washington Street East
Post Office Box 50130
Charleston, WV 25305-0130

CONTRACTOR LICENSE

Authorized by the

West Virginia Contractor Licensing Board

Number: WV014839

Classification:

GENERAL BUILDING

UNISYS CORPORATION
PO BOX 2349
CHARLESTON, WV 25328

Date Issued

Expiration Date

JULY 01, 2007	JULY 01, 2008
---------------	---------------



**WEST VIRGINIA
CONTRACTOR
LICENSING
BOARD**

Authorized Company Signature

Chair, West Virginia Contractor
Licensing Board

This license, or a copy thereof, must be posted in a conspicuous place at every construction site where work is being performed. This license number must appear in all advertisements, on all bid submissions and on all fully executed and binding contracts. This license cannot be assigned or transferred by licensee. Issued under provisions of West Virginia Code, Chapter 21, Article 11.

THE AMERICAN INSTITUTE OF ARCHITECTS



AIA Document A310

Bid Bond

KNOW ALL MEN BY THESE PRESENTS, that we UNISYS CORPORATION
(Here insert full name and address or legal title of Contractor)
Township Line & union Meeting Roads, Blue Bell, PA 19422
as Principal, hereinafter called the Principal, and LIBERTY MUTUAL INSURANCE COMPANY
(Here insert full name and address or legal title of Surety)
512 Township Line Road, Suite 350, 3 Valley Square, Blue Bell, PA 19422
a corporation duly organized under the laws of the State of MASSACHUSETTS *
as Surety, hereinafter called the Surety, are held and firmly bound unto State of West Virginia
(Here insert full name and address or legal title of Owner)
c/o West Virginia Auditor's Office, 1900 Kanawah Blvd., Bldg. 1, Charleston, WV 25305
as Obligee, hereinafter called the Obligee, in the sum of 5% of the Amount Bid

Dollars (\$ _____),
for the payment of which sum well and truly to be made, the said Principal and the said Surety, bind ourselves, our heirs, executors, administrators, successors and assigns, jointly and severally, firmly by these presents.

WHEREAS, the Principal has submitted a bid for _____
(Here insert full name, address and description of project)
Computer Room HVAC and UPS Product Installation

NOW, THEREFORE, if the Obligee shall accept the bid of the Principal and the Principal shall enter into a Contract with the Obligee in accordance with the terms of such bid, and give such bond or bonds as may be specified in the bidding or Contract Documents with good and sufficient surety for the faithful performance of such Contract and for the prompt payment of labor and material furnished in the prosecution thereof, or in the event of the failure of the Principal to enter such Contract and give such bond or bonds, if the Principal shall pay to the Obligee the difference not to exceed the penalty hereof between the amount specified in said bid and such larger amount for which the Obligee may in good faith contract with another party to perform the Work covered by said bid, then this obligation shall be null and void, otherwise to remain in full force and effect.

Signed and sealed this 19th day of December 19 2007

<u>Louise M. Krawczyk</u> <small>(Witness)</small>	<u>UNISYS CORPORATION</u> <small>(Principal)</small> <small>(Seal)</small>
	BY: <u>James G. McMullen</u> <small>(Title)</small> Director, Risk Management
<u>B. Curtin</u> <small>(Witness)</small>	<u>LIBERTY MUTUAL INSURANCE COMPANY</u> <small>(Surety)</small> <small>(Seal)</small>
	BY: <u>Neil C. Donovan</u> <small>(Title)</small> Attorney-in-fact

* and authorized to transact business in the State of West Virginia

THIS POWER OF ATTORNEY IS NOT VALID UNLESS IT IS PRINTED ON RED BACKGROUND.

This Power of Attorney limits the acts of those named herein, and they have no authority to bind the Company except in the manner and to the extent herein stated.

LIBERTY MUTUAL INSURANCE COMPANY
BOSTON, MASSACHUSETTS
POWER OF ATTORNEY

KNOW ALL PERSONS BY THESE PRESENTS: That Liberty Mutual Insurance Company (the "Company"), a Massachusetts stock insurance company, pursuant to and by authority of the By-law and Authorization hereinafter set forth, does hereby name, constitute and appoint

RICHARD H. SHEPHERD, R. H. SHEPHERD, JR., ALAN R. HEIN, DAVID E. KELLS, JR., DAVID B. KANE, ROBERT J. COLMAN, NEIL C. DONOVAN, ALL OF THE CITY OF FORT WASHINGTON, STATE OF PENNSYLVANIA

each individually if there be more than one named, its true and lawful attorney-in-fact to make, execute, seal, acknowledge and deliver, for and on its behalf as surety and as its act and deed, any and all undertakings, bonds, recognizances and other surety obligations in the penal sum not exceeding EIGHTY MILLION AND 00/100 DOLLARS (\$ 80,000,000.00) each, and the execution of such undertakings, bonds, recognizances and other surety obligations, in pursuance of these presents, shall be as binding upon the Company as if they had been duly signed by the president and attested by the secretary of the Company in their own proper persons.

That this power is made and executed pursuant to and by authority of the following By-law and Authorization:

ARTICLE XIII - Execution of Contracts: Section 5. Surety Bonds and Undertakings.

Any officer of the Company authorized for that purpose in writing by the chairman or the president, and subject to such limitations as the chairman or the president may prescribe, shall appoint such attorneys-in-fact, as may be necessary to act in behalf of the Company to make, execute, seal, acknowledge and deliver as surety any and all undertakings, bonds, recognizances and other surety obligations. Such attorneys-in-fact, subject to the limitations set forth in their respective powers of attorney, shall have full power to bind the Company by their signature and execution of any such instruments and to attach thereto the seal of the Company. When so executed such instruments shall be as binding as if signed by the president and attested by the secretary.

By the following instrument the chairman or the president has authorized the officer or other official named therein to appoint attorneys-in-fact:

Pursuant to Article XIII, Section 5 of the By-Laws, Garnet W. Elliott, Assistant Secretary of Liberty Mutual Insurance Company, is hereby authorized to appoint such attorneys-in-fact as may be necessary to act in behalf of the Company to make, execute, seal, acknowledge and deliver as surety any and all undertakings, bonds, recognizances and other surety obligations.

That the By-law and the Authorization set forth above are true copies thereof and are now in full force and effect.

IN WITNESS WHEREOF, this Power of Attorney has been subscribed by an authorized officer or official of the Company and the corporate seal of Liberty Mutual Insurance Company has been affixed thereto in Plymouth Meeting, Pennsylvania this 12th day of October, 2007.

LIBERTY MUTUAL INSURANCE COMPANY

By Garnet W. Elliott, Assistant Secretary



COMMONWEALTH OF PENNSYLVANIA ss
COUNTY OF MONTGOMERY

On this 12th day of October, 2007, before me, a Notary Public, personally came Garnet W. Elliott, to me known, and acknowledged that he is an Assistant Secretary of Liberty Mutual Insurance Company; that he knows the seal of said corporation; and that he executed the above Power of Attorney and affixed the corporate seal of Liberty Mutual Insurance Company thereto with the authority and at the direction of said corporation.

IN TESTIMONY WHEREOF, I have hereunto subscribed my name and affixed my notarial seal at Plymouth Meeting, Pennsylvania, on the day and year first above written.



COMMONWEALTH OF PENNSYLVANIA
Notarial Seal
Teresa Pastella, Notary Public
Plymouth Twp., Montgomery County
My Commission Expires Mar. 28, 2009
Member, Pennsylvania Association of Notaries

By Teresa Pastella, Notary Public

CERTIFICATE

I, the undersigned, Assistant Secretary of Liberty Mutual Insurance Company, do hereby certify that the original power of attorney of which the foregoing is a full, true and correct copy, is in full force and effect on the date of this certificate; and I do further certify that the officer or official who executed the said power of attorney is an Assistant Secretary specially authorized by the chairman or the president to appoint attorneys-in-fact as provided in Article XIII, Section 5 of the By-laws of Liberty Mutual Insurance Company.

This certificate and the above power of attorney may be signed by facsimile or mechanically reproduced signatures under and by authority of the following vote of the board of directors of Liberty Mutual Insurance Company at a meeting duly called and held on the 12th day of March, 1980.

VOTED that the facsimile or mechanically reproduced signature of any assistant secretary of the company, wherever appearing upon a certified copy of any power of attorney issued by the company in connection with surety bonds, shall be valid and binding upon the company with the same force and effect as though manually affixed.

IN TESTIMONY WHEREOF, I have hereunto subscribed my name and affixed the corporate seal of the said company, this 19th day of December, 2007.



By David M. Carey, Assistant Secretary

Not valid for mortgage, note, loan, letter of credit, bank deposit, currency rate, interest rate or residual value guarantees.

To confirm the validity of this Power of Attorney call 1-610-832-8240 between 9:00 am and 4:30 pm EST on any business day.

ASSETS

	Current Year			Prior Year
	1	2	3	4
	Assets	Nonadmitted Assets	Net Admitted Assets (Cols. 1 - 2)	Net Admitted Assets
1. Bonds (Schedule D)	14,335,788,460		14,335,788,460	12,556,562,894
2. Stocks (Schedule D):				
2.1 Preferred stocks	234,308,916		234,308,916	59,716,597
2.2 Common stocks	5,059,085,324		5,059,085,324	5,205,385,257
3. Mortgage loans on real estate (Schedule E):				
3.1 First liens	249,560,820		249,560,820	39,500,000
3.2 Other than first liens				
4. Real estate (Schedule A):				
4.1 Properties occupied by the company (less \$ 0 encumbrances)	326,163,102		326,163,102	311,128,829
4.2 Properties held for the production of income (less \$ 0 encumbrances)	1,111,445		1,111,445	1,159,491
4.3 Properties held for sale (less \$ 0 encumbrances)				
5. Cash (\$ 395,782,418, Schedule E-Part 1), cash equivalents (\$ 281,179,343, Schedule E-Part 2) and short-term investments (\$ 550,704,122, Schedule DA)	1,207,665,883		1,207,665,883	1,092,172,507
6. Contract loans (including \$ 0 premium notes)				
7. Other invested assets (Schedule BA)	3,449,595,595	2,300,145	3,447,295,251	2,213,512,480
8. Receivables for securities	41,352,591		41,352,591	31,985,363
9. Aggregate write-ins for invested assets				
10. Subtotals, cash and invested assets (Lines 1 to 9)	24,914,631,997	2,300,145	24,912,331,852	21,500,663,783
11. Title plants less \$ 0 charged off (for Title insurers only)				
12. Investment income due and accrued	168,971,988		168,971,988	155,875,613
13. Premiums and considerations:				
13.1 Uncollected premiums and agents' balances in the course of collection	723,928,481	20,859,359	703,139,102	635,279,658
13.2 Deferred premiums, agents' balances and installments booked but deferred and not yet due (including \$ 30,275 earned but unbilled premiums)	1,462,232,711	3,353	1,462,229,358	1,376,405,401
13.3 Accrued retrospective premiums	513,351,472	50,634,071	462,717,401	468,226,952
14. Reinsurance:				
14.1 Amounts recoverable from reinsurers	740,190,011		740,190,011	399,753,189
14.2 Funds held by or deposited with reinsured companies	78,958,530		78,958,530	24,877,116
14.3 Other amounts receivable under reinsurance contracts				
15. Amounts receivable relating to uninsured plans	2,139,944	2,139,944		
16.1 Current federal and foreign income tax recoverable and interest thereon	13,749,786		13,749,786	56,065,885
16.2 Net deferred tax asset	649,760,000	94,673,994	555,086,006	585,267,577
17. Guaranty funds receivable or on deposit	32,691,812		32,691,812	27,653,992
18. Electronic data processing equipment and software	254,089,175	211,328,371	42,760,804	44,331,941
19. Furniture and equipment, including health care delivery assets (\$ 0)	27,291,290	27,291,290		
20. Net adjustment in assets and liabilities due to foreign exchange rates				
21. Receivables from parent, subsidiaries and affiliates	235,522,572		235,522,572	284,222,350
22. Health care (\$ 0) and other amounts receivable				
23. Aggregate write-ins for other than invested assets	611,805,981	100,144,114	511,661,867	440,184,632
24. Total assets excluding Separate Accounts, Segregated Accounts and Protected Cell Accounts (Lines 10 to 23)	30,429,386,730	509,374,641	29,920,012,089	26,011,608,289
25. From Separate Accounts, Segregated Accounts and Protected Cell Accounts				
26. Total (Lines 24 and 25)	30,429,386,730	509,374,641	29,920,012,089	26,011,608,289

DETAILS OF WRITE-INS				
0901.				
0902.				
0903.				
0998. Summary of remaining write-ins for Line 09 from overflow page				
0999. Totals (Lines 0901 through 0903 plus 0998) (Line 09 above)				
2301. Other assets	255,681,228	91,247,443	164,433,785	109,835,787
2302. Cash surrender value life insurance	162,038,957		162,038,957	143,031,210
2303. Equities and deposits in pools and associations	20,497,883		20,497,883	20,932,222
2399. Summary of remaining write-ins for Line 23 from overflow page	173,587,913	8,896,671	164,691,242	166,335,613
2399. Totals (Lines 2301 through 2303 plus 2399) (Line 23 above)	611,805,981	100,144,114	511,661,867	440,184,632