



State of West Virginia
 Department of Administration
 Purchasing Division
 2019 Washington Street East
 Post Office Box 50130
 Charleston, WV 25305-0130

Request for Quotation

RFQ NUMBER
708EC009

PAGE
1

ADDRESS CORRESPONDENCE TO ATTENTION OF
**MICHAEL AUSTIN
 304-558-2402**

PURCHASER

RFQ COPY
TYPE NAME/ADDRESS HERE
 Middletown Tractor Sales
 2345 Whitehall Blvd
 Fairmont WV 26554

SHIP TO

**DIVISION OF HIGHWAYS
 EQUIPMENT DIVISION
 ROUTE 33
 BRUSHY FORK ROAD
 BUCKHANNON, WV
 26201 304-472-1750**

DATE PRINTED	TERMS OF SALE	SHIP VIA	FOB	FREIGHT TERMS
01/16/2008	Net 30	Our Truck	Destination	Pre Paid

BID OPENING DATE: **02/13/2008** BID OPENING TIME **01:30PM**

LINE	QUANTITY	UOP	CAT NO	ITEM NUMBER	UNIT PRICE	AMOUNT
0001	1	EA		765-61		
<p>SNOWPLOW (HYDRAULIC) Monroe MP41R10 WVA 10' Hydraulic snowplow Monroe MP41R11 WVA 11' Hydraulic snowplow TO PROVIDE 10 FOOT OR 11 FOOT POWER REVERSIBLE SNOWPLOW (HYDRAULIC) PER THE ATTACHED SPECIFICATIONS.</p> <p>THERE WILL BE A MANDATORY PRE-BID CONFERENCE AT THE STATE CAPITOL COMPLEX, BUILDING 15, 2019 WASHINGTON ST. EAST. CHARLESTON, WV 25305 AT 10:00 AM ON 01/31/08. FAILURE TO ATTEND THE PRE-BID WILL RESULT IN BID DISQUALIFICATION.</p> <p>QUESTIONS: WRITTEN QUESTIONS WILL BE ACCEPTED THROUGH CLOSE OF BUSINESS (5:00 PM EST.) ON MONDAY 01/28/2008. SEND YOUR QUESTIONS TO: PURCHASING DIVISION ATTENTION: MICHAEL AUSTIN 2019 WASHINGTON STREET EAST CHARLESTON, WV 25305</p> <p>QUESTIONS MAY BE SENT VIA FAX, E-MAIL OR REGULAR MAIL E-MAIL: MICHAEL.D.AUSTIN@WV.GOV FAX: 304-558-4115</p> <p>IT IS THE VENDORS RESPONSIBILITY TO VERIFY THAT THEIR QUESTIONS HAVE BEEN RECEIVED BY CALLING 304-558-2402.</p> <p>EXHIBIT 2</p> <p>LIFE OF CONTRACT: THIS CONTRACT BECOMES EFFECTIVE ON AND EXTENDS FOR A PERIOD OF ONE (1) YEAR OR UNTIL SUCH "REASONABLE TIME" THEREAFTER AS IS NECESSARY TO OBTAIN A NEW CONTRACT OR RENEW THE</p>						

RECEIVED
 2008 MAR -5 A 9:59
 PURCHASING DIVISION
 STATE OF WV

SEE REVERSE SIDE FOR TERMS AND CONDITIONS

SIGNATURE: *J. Adam B...* TELEPHONE: (304) 366-4690 DATE: 03-03-2008
 TITLE: VP FEIN: 55-0547175 ADDRESS CHANGES TO BE NOTED ABOVE

WHEN RESPONDING TO RFQ, INSERT NAME AND ADDRESS IN SPACE ABOVE LABELED 'VENDOR'

**GENERAL TERMS & CONDITIONS
REQUEST FOR QUOTATION (RFQ) AND REQUEST FOR PROPOSAL (RFP)**

1. Awards will be made in the best interest of the State of West Virginia.
2. The State may accept or reject in part, or in whole, any bid.
3. All quotations are governed by the *West Virginia Code* and the *Legislative Rules* of the Purchasing Division.
4. Prior to any award, the apparent successful vendor must be properly registered with the Purchasing Division and have paid the required \$125.00 registration fee.
5. All services performed or goods delivered under State Purchase Orders/Contracts are to be continued for the term of the Purchase Order/Contract, contingent upon funds being appropriated by the Legislature or otherwise being made available. In the event funds are not appropriated or otherwise available for these services or goods, this Purchase Order/Contract becomes void and of no effect after June 30.
6. Payment may only be made after the delivery and acceptance of goods or services.
7. Interest may be paid for late payment in accordance with the *West Virginia Code*.
8. Vendor preference will be granted upon written request in accordance with the *West Virginia Code*.
9. The State of West Virginia is exempt from federal and state taxes and will not pay or reimburse such taxes.
10. The Director of Purchasing may cancel any Purchase Order/Contract upon 30 days written notice to the seller.
11. The laws of the State of West Virginia and the *Legislative Rules* of the Purchasing Division shall govern all rights and duties under the Contract, including without limitation the validity of this Purchase Order/Contract.
12. Any reference to automatic renewal is hereby deleted. The Contract may be renewed only upon mutual written agreement of the parties.
13. **BANKRUPTCY:** In the event the vendor/contractor files for bankruptcy protection, this Contract may be deemed null and void, and terminated without further order.
14. **HIPAA Business Associate Addendum -** The West Virginia State Government HIPAA Business Associate Addendum (BAA), approved by the Attorney General, and available online at the Purchasing Division's web site (<http://www.state.wv.us/admin/purchase/vrc/hipaa.htm>) is hereby made part of the agreement. Provided that, the Agency meets the definition of a Covered Entity (45 CFR §160.103) and will be disclosing Protected Health Information (45 CFR §160.103) to the vendor.

INSTRUCTIONS TO BIDDERS

1. Use the quotation forms provided by the Purchasing Division.
2. **SPECIFICATIONS:** Items offered must be in compliance with the specifications. Any deviation from the specifications must be clearly indicated by the bidder. Alternates offered by the bidder as **EQUAL** to the specifications must be clearly defined. A bidder offering an alternate should attach complete specifications and literature to the bid. The Purchasing Division may waive minor deviations to specifications.
3. Complete all sections of the quotation form.
4. Unit prices shall prevail in cases of discrepancy.
5. All quotations are considered F.O.B. destination unless alternate shipping terms are clearly identified in the quotation.
6. **BID SUBMISSION:** All quotations must be delivered by the bidder to the office listed below prior to the date and time of the bid opening. Failure of the bidder to deliver the quotations on time will result in bid disqualifications.

SIGNED BID TO:

Department of Administration
Purchasing Division
2019 Washington Street East
Post Office Box 50130
Charleston, WV 25305-0130



State of West Virginia
 Department of Administration
 Purchasing Division
 2019 Washington Street East
 Post Office Box 50130
 Charleston, WV 25305-0130

Request for Quotation

RFQ NUMBER
708EC009

PAGE
2

ADDRESS CORRESPONDENCE TO ATTENTION OF
MICHAEL AUSTIN 304-558-2402

RFQ COPY

TYPE NAME/ADDRESS HERE

Middletown Tractor Sales
 2345 Whitehall Blvd
 Fairmont WV 26554

DIVISION OF HIGHWAYS

EQUIPMENT DIVISION
 ROUTE 33
 BRUSHY FORK ROAD
 BUCKHANNON, WV
 26201 304-472-1750

DATE PRINTED	TERMS OF SALE	SHIP VIA	FOB	FREIGHT TERMS
01/16/2008	Net 30	Our Truck	Destination	Pre Paid
BID OPENING DATE: 02/13/2008		BID OPENING TIME 01:30PM		

LINE	QUANTITY	UOP	CAT NO	ITEM NUMBER	UNIT PRICE	AMOUNT
<p>ORIGINAL CONTRACT. THE "REASONABLE TIME" PERIOD SHALL NOT EXCEED TWELVE (12) MONTHS. DURING THIS "REASONABLE TIME" THE VENDOR MAY TERMINATE THIS CONTRACT FOR ANY REASON UPON GIVING THE DIRECTOR OF PURCHASING THIRTY (30) DAYS WRITTEN NOTICE.</p> <p>UNLESS SPECIFIC PROVISIONS ARE STIPULATED IN THIS CONTRACT DOCUMENT, THE TERMS, CONDITIONS, AND PRICING SET HEREIN ARE FIRM FOR THE LIFE OF THE CONTRACT.</p> <p>RENEWAL: THIS CONTRACT MAY BE RENEWED UPON THE MUTUAL WRITTEN CONSENT OF THE SPENDING UNIT AND VENDOR, SUBMITTED TO THE DIRECTOR OF PURCHASING THIRTY (30) DAYS PRIOR TO THE EXPIRATION DATE. SUCH RENEWAL SHALL BE IN ACCORDANCE WITH THE TERMS AND CONDITIONS OF THE ORIGINAL CONTRACT AND SHALL BE LIMITED TO TWO (2) ONE (1) YEAR PERIODS.</p> <p>CANCELLATION: THE DIRECTOR OF PURCHASING RESERVES THE RIGHT TO CANCEL THIS CONTRACT IMMEDIATELY UPON WRITTEN NOTICE TO THE VENDOR IF THE COMMODITIES AND/OR SERVICES SUPPLIED ARE OF AN INFERIOR QUALITY OR DO NOT CONFORM WITH THE SPECIFICATIONS OF THE BID AND CONTRACT HEREIN.</p> <p>OPEN MARKET CLAUSE: THE DIRECTOR OF PURCHASING MAY AUTHORIZE A SPENDING UNIT TO PURCHASE ON THE OPEN MARKET, WITHOUT THE FILING OF A REQUISITION OR COST ESTIMATE, ITEMS SPECIFIED ON THIS CONTRACT FOR IMMEDIATE DELIVERY IN EMERGENCIES DUE TO UNFORESEEN CAUSES (INCLUDING BUT NOT LIMITED TO DELAYS IN TRANSPORTATION OR AN UNANTICIPATED INCREASE IN THE VOLUME OF WORK).</p> <p>QUANTITIES: QUANTITIES LISTED IN THE REQUISITION ARE APPROXIMATIONS ONLY, BASED ON ESTIMATES SUPPLIED BY THE STATE SPENDING UNIT. IT IS UNDERSTOOD AND AGREED THAT THE CONTRACT SHALL COVER THE QUANTITIES ACTUALLY</p>						

SEE REVERSE SIDE FOR TERMS AND CONDITIONS

SIGNATURE	TELEPHONE	DATE
<i>J. Boyer</i>	(304) 366-4690	03-03-2008
TITLE	FEIN	ADDRESS CHANGES TO BE NOTED ABOVE
VP	55-0547175	

WHEN RESPONDING TO RFQ, INSERT NAME AND ADDRESS IN SPACE ABOVE LABELED 'VENDOR'



State of West Virginia
 Department of Administration
 Purchasing Division
 2019 Washington Street East
 Post Office Box 50130
 Charleston, WV 25305-0130

Request for Quotation

RFQ NUMBER
708EC009

PAGE
3

ADDRESS CORRESPONDENCE TO ATTENTION OF
**MICHAEL AUSTIN
 304-558-2402**

RFQ COPY

TYPE NAME/ADDRESS HERE
 Middletown Tractor Sales
 2345 Whitehall Blvd
 Fairmont WV 26554

**DIVISION OF HIGHWAYS
 EQUIPMENT DIVISION
 ROUTE 33
 BRUSHY FORK ROAD
 BUCKHANNON, WV
 26201 304-472-1750**

DATE PRINTED	TERMS OF SALE	SHIP VIA	FOB	FREIGHT TERMS
01/16/2008	Net 30	Our Truck	Destination	Pre Paid
BID OPENING DATE: 02/13/2008		BID OPENING TIME 01:30PM		

LINE	QUANTITY	UOP	CAT. NO.	ITEM NUMBER	UNIT PRICE	AMOUNT
<p>ORDERED FOR DELIVERY DURING THE TERM OF CONTRACT, WHETHER MORE OR LESS THAN THE QUANTITIES SHOWN.</p> <p>ORDERING PROCEDURE: SPENDING UNIT(S) SHALL ISSUE A WRITTEN EQUIPMENT CONTRACT ORDER (FORM NUMBER WV-35) FOR COMMODITIES COVERED BY THIS CONTRACT. THE ORIGINAL WV-35 MUST BE SENT TO THE PURCHASING DIVISION OF THE DEPARTMENT OF ADMINISTRATION. AFTER APPROVAL AND ENCUMBRANCE, ONE COPY OF THE PURCHASE ORDER WILL BE RETURNED TO THE SPENDING UNIT AND ONE COPY FORWARDED TO THE VENDOR AS AUTHORIZATION FOR SHIPMENT. NO ORDER IS VALID UNLESS APPROVED AND ENCUMBERED BY THE PURCHASING DIVISION.</p> <p>BANKRUPTCY: IN THE EVENT THE VENDOR/CONTRACTOR FILES FOR BANKRUPTCY PROTECTION, THIS CONTRACT IS AUTOMATICALLY NULL AND VOID, AND IS TERMINATED WITHOUT FURTHER ORDER.</p> <p>REV. 9/98</p> <p>EXHIBIT 6</p> <p>PRICE ADJUSTMENT PROVISION: THE STATE OF WEST VIRGINIA WILL CONSIDER BIDS THAT CONTAIN PROVISIONS FOR PRICE ADJUSTMENTS PRIOR TO THE ORIGINAL EXPIRATION OF THE CONTRACT, PROVIDED THAT SUCH PRICE ADJUSTMENT COVERS BOTH UPWARD AND DOWNWARD MOVEMENT OF THE COMMODITY PRICE, AND THAT ADJUSTMENT IS BASED ON THE "PASS THROUGH" INCREASE OR DECREASE OF RAW MATERIALS AND/OR LABOR, WHICH MAKE UP ALL OR A SUBSTANTIAL PART OF A PRODUCT. ADJUSTMENTS ARE TO BE BASED UPON AN ACTUAL DOLLAR FIGURE, NOT A PERCENTAGE. ALL PRICE ADJUSTMENT REQUESTS MUST BE SUBSTANTIATED IN A MANNER ACCEPTABLE TO THE DIRECTOR PURCHASING, E.G.</p>						

SEE REVERSE SIDE FOR TERMS AND CONDITIONS

SIGNATURE <i>J. Boyer</i>	TELEPHONE (304)366-4690	DATE 03-03-2008
TITLE <i>VP</i>	FEIN 55-0547175	ADDRESS CHANGES TO BE NOTED ABOVE

WHEN RESPONDING TO RFQ, INSERT NAME AND ADDRESS IN SPACE ABOVE LABELED 'VENDOR'



State of West Virginia
 Department of Administration
 Purchasing Division
 2019 Washington Street East
 Post Office Box 50130
 Charleston, WV 25305-0130

Request for Quotation

RFQ NUMBER
708EC009

PAGE
4

ADDRESS CORRESPONDENCE TO ATTENTION OF
**MICHAEL AUSTIN
 304-558-2402**

RFQ COPY

TYPE NAME/ADDRESS HERE
 Middletown Tractor Sales
 2345 Whitehall Blvd
 Fairmont WV 26554

SHIP TO

**DIVISION OF HIGHWAYS
 EQUIPMENT DIVISION
 ROUTE 33
 BRUSHY FORK ROAD
 BUCKHANNON, WV
 26201 304-472-1750**

DATE PRINTED	TERMS OF SALE	SHIP VIA	FOB	FREIGHT TERMS
01/16/2008	Net 30	Our Truck	Destination	Pre Paid

BID OPENING DATE: **02/13/2008** **BID OPENING TIME 01:30PM**

LINE	QUANTITY	UOP	CAT NO	ITEM NUMBER	UNIT PRICE	AMOUNT
<p>GOVERNMENTAL BENCH MARKS, GENERAL MARKET INCREASE, PUBLISHED PRICE LISTS. SUCH REQUESTS FOR AND INCREASE SHOULD BE RECEIVED IN WRITING BY THE DIRECTOR OF PURCHASING AT LEAST 30 DAYS IN ADVANCE OF THE EFFECTIVE DATE OF THE INCREASE. ANY TIME THE VENDOR REQUESTS A PRICE ADJUSTMENT, THE PURCHASING DIVISION MAY EITHER ACCEPT THE PRICE ADJUSTMENT AND AMEND THE CONTRACT ACCORDINGLY OR REJECT THE ADJUSTMENT IN ITS ENTIRETY AND CANCEL THE CONTRACT.</p> <p>EXHIBIT 10</p> <p>REQUISITION NO.: 708EC009</p> <p>ADDENDUM ACKNOWLEDGEMENT</p> <p>I HEREBY ACKNOWLEDGE RECEIPT OF THE FOLLOWING CHECKED ADDENDUM(S) AND HAVE MADE THE NECESSARY REVISIONS TO MY PROPOSAL, PLANS AND/OR SPECIFICATION, ETC.</p> <p>ADDENDUM NO.'S:</p> <p>NO. 1 .X.....</p> <p>NO. 2 .X.....</p> <p>NO. 3</p> <p>NO. 4</p> <p>NO. 5</p> <p>I UNDERSTAND THAT FAILURE TO CONFIRM THE RECEIPT OF THE ADDENDUM(S) MAY BE CAUSE FOR REJECTION OF BIDS.</p>						

SEE REVERSE SIDE FOR TERMS AND CONDITIONS

SIGNATURE <i>A Boyer</i>	TELEPHONE (304)366-4690	DATE 03-03-2008
TITLE <i>VP</i>	FEIN 55-0547175	ADDRESS CHANGES TO BE NOTED ABOVE

WHEN RESPONDING TO RFQ, INSERT NAME AND ADDRESS IN SPACE ABOVE LABELED 'VENDOR'



State of West Virginia
 Department of Administration
 Purchasing Division
 2019 Washington Street East
 Post Office Box 50130
 Charleston, WV 25305-0130

Request for Quotation

RFQ NUMBER
708EC009

PAGE
5

ADDRESS CORRESPONDENCE TO ATTENTION OF
**MICHAEL AUSTIN
 304-558-2402**

RFQ COPY

TYPE NAME/ADDRESS HERE

Middletown Tractor Sales
 2345 Whitehall Blvd
 Fairmont WV 26554

**DIVISION OF HIGHWAYS
 EQUIPMENT DIVISION
 ROUTE 33
 BRUSHY FORK ROAD
 BUCKHANNON, WV
 26201**

304-472-1750

DATE PRINTED	TERMS OF SALE	SHIP VIA	FOB	FREIGHT TERMS
01/16/2008	Net 30	Our Truck	Destination	Pre Paid
BID OPENING DATE: 02/13/2008		BID OPENING TIME 01:30PM		

LINE	QUANTITY	UOP	CAT NO	ITEM NUMBER	UNIT PRICE	AMOUNT
<p>VENDOR MUST CLEARLY UNDERSTAND THAT ANY VERBAL REPRESENTATION MADE OR ASSUMED TO BE MADE DURING ANY ORAL DISCUSSION HELD BETWEEN VENDOR'S REPRESENTATIVES AND ANY STATE PERSONNEL IS NOT BINDING. ONLY THE INFORMATION ISSUED IN WRITING AND ADDED TO THE SPECIFICATIONS BY AN OFFICIAL ADDENDUM IS BINDING.</p> <p style="text-align: center;">  SIGNATURE MIDDLETOWN TRACTOR SALES COMPANY 3/3/08 DATE </p> <p>REV. 11/96</p> <p style="text-align: center;">VENDOR PREFERENCE CERTIFICATE</p> <p>CERTIFICATION AND APPLICATION* IS HEREBY MADE FOR PREFERENCE IN ACCORDANCE WITH WEST VIRGINIA CODE, 5A-3-37 (DOES NOT APPLY TO CONSTRUCTION CONTRACTS).</p> <p>A. APPLICATION IS MADE FOR 2.5% PREFERENCE FOR THE REASON CHECKED:</p> <p>() BIDDER IS AN INDIVIDUAL RESIDENT VENDOR AND HAS RESIDED CONTINUOUSLY IN WEST VIRGINIA FOR FOUR (4) YEARS IMMEDIATELY PRECEDING THE DATE OF THIS CERTIFICATION; OR</p> <p>(X) BIDDER IS A PARTNERSHIP, ASSOCIATION OR CORPORATION RESIDENT VENDOR AND HAS MAINTAINED ITS HEAD-</p>						

SEE REVERSE SIDE FOR TERMS AND CONDITIONS

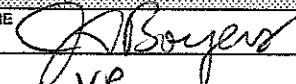
SIGNATURE 	TELEPHONE (304) 366-4690	DATE 03-03-2008
TITLE VP	FEIN 55-0547175	ADDRESS CHANGES TO BE NOTED ABOVE

WHEN RESPONDING TO RFQ, INSERT NAME AND ADDRESS IN SPACE ABOVE LABELED 'VENDOR'



State of West Virginia
 Department of Administration
 Purchasing Division
 2019 Washington Street East
 Post Office Box 50130
 Charleston, WV 25305-0130

Request for Quotation

RFQ NUMBER
708EC009

PAGE
6

ADDRESS CORRESPONDENCE TO ATTENTION OF
MICHAEL AUSTIN
304-558-2402

RFQ COPY

TYPE NAME/ADDRESS HERE

Middletown Tractor Sales
 2345 Whitehall Blvd
 Fairmont WV 26554

DIVISION OF HIGHWAYS
EQUIPMENT DIVISION
ROUTE 33
BRUSHY FORK ROAD
BUCKHANNON, WV
26201 **304-472-1750**

DATE PRINTED	TERMS OF SALE	SHIP VIA	FOB	FREIGHT TERMS
01/16/2008	Net 30	Our Truck	Destination	Pre Paid
BID OPENING DATE: 02/13/2008		BID OPENING TIME 01:30PM		

LINE	QUANTITY	UOP	CAT NO	ITEM NUMBER	UNIT PRICE	AMOUNT
<p>QUARTERS OR PRINCIPAL PLACE OF BUSINESS CONTINUOUSLY IN WEST VIRGINIA FOR FOUR (4) YEARS IMMEDIATELY PRECEDING THE DATE OF THIS CERTIFICATION; OR 80% OF THE OWNERSHIP INTEREST OF BIDDER IS HELD BY ANOTHER INDIVIDUAL, PARTNERSHIP, ASSOCIATION OR CORPORATION RESIDENT VENDOR WHO HAS MAINTAINED ITS HEADQUARTERS OR PRINCIPAL PLACE OF BUSINESS CONTINUOUSLY IN WEST VIRGINIA FOR FOUR (4) YEARS IMMEDIATELY PRECEDING THE DATE OF THIS CERTIFICATION; OR</p> <p>() BIDDER IS A CORPORATION NONRESIDENT VENDOR WHICH HAS AN AFFILIATE OR SUBSIDIARY WHICH EMPLOYS A MINIMUM OF ONE HUNDRED STATE RESIDENTS AND WHICH HAS MAINTAINED ITS HEADQUARTERS OR PRINCIPAL PLACE OF BUSINESS WITHIN WEST VIRGINIA CONTINUOUSLY FOR THE FOUR (4) YEARS IMMEDIATELY PRECEDING THE DATE OF THIS CERTIFICATION.</p> <p>B. APPLICATION IS MADE FOR 2.5% PREFERENCE FOR THE REASON CHECKED:</p> <p>(X) BIDDER IS A RESIDENT VENDOR WHO CERTIFIES THAT, DURING THE LIFE OF THE CONTRACT, ON AVERAGE AT LEAST 75% OF THE EMPLOYEES WORKING ON THE PROJECT BEING BID ARE RESIDENTS OF WEST VIRGINIA WHO HAVE RESIDED IN THE STATE CONTINUOUSLY FOR THE TWO YEARS IMMEDIATELY PRECEDING SUBMISSION OF THIS BID;</p> <p>OR</p> <p>() BIDDER IS A NONRESIDENT VENDOR EMPLOYING A MINIMUM OF ONE HUNDRED STATE RESIDENTS OR IS A NONRESIDENT VENDOR WITH AN AFFILIATE OR SUBSIDIARY WHICH MAINTAINS ITS HEADQUARTERS OR PRINCIPAL PLACE OF BUSINESS WITHIN WEST VIRGINIA EMPLOYING A MINIMUM OF ONE HUNDRED STATE RESIDENTS WHO CERTIFIES THAT, DURING THE LIFE OF THE CONTRACT, ON AVERAGE AT LEAST 75% OF THE EMPLOYEES OR BIDDERS' AFFILIATE'S OR</p>						

SEE REVERSE SIDE FOR TERMS AND CONDITIONS

SIGNATURE <i>[Signature]</i>	TELEPHONE (304) 366-4690	DATE 03-03-2008
TITLE VP	FEIN 55-0547175	ADDRESS CHANGES TO BE NOTED ABOVE

WHEN RESPONDING TO RFQ, INSERT NAME AND ADDRESS IN SPACE ABOVE LABELED 'VENDOR'



State of West Virginia
 Department of Administration
 Purchasing Division
 2019 Washington Street East
 Post Office Box 50130
 Charleston, WV 25305-0130

Request for Quotation

RFQ NUMBER
708EC009

PAGE
7

ADDRESS CORRESPONDENCE TO ATTENTION OF
MICHAEL AUSTIN 304-558-2402

RFQ COPY

TYPE NAME/ADDRESS HERE
 Middletown Tractor Sales
 2345 Whitehall Blvd
 Fairmont WV 26554

DIVISION OF HIGHWAYS
 EQUIPMENT DIVISION
 ROUTE 33
 BRUSHY FORK ROAD
 BUCKHANNON, WV
 26201 304-472-1750

DATE PRINTED	TERMS OF SALE	SHIP VIA	F.O.B.	FREIGHT TERMS
01/16/2008	Net 30	Our Truck	Destination	Pre Paid
BID OPENING DATE: 02/13/2008		BID OPENING TIME 01:30PM		

LINE	QUANTITY	UOP	CAT NO	ITEM NUMBER	UNIT PRICE	AMOUNT
<p>SUBSIDIARY'S EMPLOYEES ARE RESIDENTS OF WEST VIRGINIA WHO HAVE RESIDED IN THE STATE CONTINUOUSLY FOR THE TWO YEARS IMMEDIATELY PRECEDING SUBMISSION OF THIS BID.</p> <p>BIDDER UNDERSTANDS IF THE SECRETARY OF TAX & REVENUE DETERMINES THAT A BIDDER RECEIVING PREFERENCE HAS FAILED TO CONTINUE TO MEET THE REQUIREMENTS FOR SUCH PREFERENCE, THE SECRETARY MAY ORDER THE DIRECTOR OF PURCHASING TO: (A) RESCIND THE CONTRACT OR PURCHASE ORDER ISSUED; OR (B) ASSESS A PENALTY AGAINST SUCH BIDDER IN AN AMOUNT NOT TO EXCEED 5% OF THE BID AMOUNT AND THAT SUCH PENALTY WILL BE PAID TO THE CONTRACTING AGENCY OR DEDUCTED FROM ANY UNPAID BALANCE ON THE CONTRACT OR PURCHASE ORDER.</p> <p>BY SUBMISSION OF THIS CERTIFICATE, BIDDER AGREES TO DISCLOSE ANY REASONABLY REQUESTED INFORMATION TO THE PURCHASING DIVISION AND AUTHORIZES THE DEPARTMENT OF TAX AND REVENUE TO DISCLOSE TO THE DIRECTOR OF PURCHASING APPROPRIATE INFORMATION VERIFYING THAT BIDDER HAS PAID THE REQUIRED BUSINESS TAXES, PROVIDED THAT SUCH INFORMATION DOES NOT CONTAIN THE AMOUNTS OF TAXES PAID NOR ANY OTHER INFORMATION DEEMED BY THE TAX COMMISSIONER TO BE CONFIDENTIAL.</p> <p>UNDER PENALTY OF LAW FOR FALSE SWEARING (WEST VIRGINIA CODE 61-5-3), BIDDER HEREBY CERTIFIES THAT THIS CERTIFICATE IS TRUE AND ACCURATE IN ALL RESPECTS; AND THAT IF A CONTRACT IS ISSUED TO BIDDER AND IF ANYTHING CONTAINED WITHIN THIS CERTIFICATE CHANGES DURING THE TERM OF THE CONTRACT, BIDDER WILL NOTIFY THE PURCHASING DIVISION IN WRITING IMMEDIATELY.</p> <p>BIDDER: <u>MIDDLE TOWN TRACTOR SALES</u></p>						

SEE REVERSE SIDE FOR TERMS AND CONDITIONS

SIGNATURE	TELEPHONE	DATE
<i>A. Boyer</i>	(304) 366-4690	03-03-2008
TITLE	FEIN	ADDRESS CHANGES TO BE NOTED ABOVE
VP	55-0547175	

WHEN RESPONDING TO RFQ, INSERT NAME AND ADDRESS IN SPACE ABOVE LABELED 'VENDOR'



State of West Virginia
 Department of Administration
 Purchasing Division
 2019 Washington Street East
 Post Office Box 50130
 Charleston, WV 25305-0130

Request for Quotation

RFQ NUMBER
708EC009

PAGE
8

ADDRESS CORRESPONDENCE TO ATTENTION OF
**MICHAEL AUSTIN
 304-558-2402**

RFQ COPY

TYPE NAME/ADDRESS HERE
 Middletown Tractor Sales
 2345 Whitehall Blvd
 Fairmont WV 26554

DIVISION OF HIGHWAYS
 EQUIPMENT DIVISION
 ROUTE 33
 BRUSHY FORK ROAD
 BUCKHANNON, WV
 26201 304-472-1750

DATE PRINTED	TERMS OF SALE	SHIP VIA	FOB	FREIGHT TERMS
01/16/2008	Net 30	Our Truck	Destination	Pre Paid

BID OPENING DATE: **02/13/2008** BID OPENING TIME **01:30PM**

LINE	QUANTITY	UOP	CAT NO	ITEM NUMBER	UNIT PRICE	AMOUNT
<p>DATE: <u>3/3/08</u></p> <p>SIGNED: <u>J. Adam Boyer</u></p> <p>TITLE: <u>VP</u></p> <p>* CHECK ANY COMBINATION OF PREFERENCE CONSIDERATION(S) IN EITHER "A" OR "B", OR BOTH "A" AND "B" WHICH YOU ARE ENTITLED TO RECEIVE. YOU MAY REQUEST UP TO THE MAXIMUM 5% PREFERENCE FOR BOTH "A" AND "B". (REV. 12/00)</p> <p>NOTICE</p> <p>A SIGNED BID MUST BE SUBMITTED TO:</p> <p>DEPARTMENT OF ADMINISTRATION PURCHASING DIVISION BUILDING 15 2019 WASHINGTON STREET, EAST CHARLESTON, WV 25305-0130</p> <p>THE BID SHOULD CONTAIN THIS INFORMATION ON THE FACE OF THE ENVELOPE OR THE BID MAY NOT BE CONSIDERED:</p> <p>SEALED BID</p> <p>BUYER: 33</p> <p>RFQ. NO.: 708EC009</p> <p>BID OPENING DATE: 02/13/2008</p>						

SEE REVERSE SIDE FOR TERMS AND CONDITIONS

SIGNATURE <u>J. Adam Boyer</u>	TELEPHONE (304-366-4690)	DATE 03-03-2008
TITLE <u>VP</u>	FEIN 55-0547175	ADDRESS CHANGES TO BE NOTED ABOVE

WHEN RESPONDING TO RFQ, INSERT NAME AND ADDRESS IN SPACE ABOVE LABELED 'VENDOR'



State of West Virginia
 Department of Administration
 Purchasing Division
 2019 Washington Street East
 Post Office Box 50130
 Charleston, WV 25305-0130

Request for Quotation

RFQ NUMBER
708EC009

PAGE
9

ADDRESS CORRESPONDENCE TO ATTENTION OF:
**MICHAEL AUSTIN
 304-558-2402**

RFQ COPY

TYPE NAME/ADDRESS HERE
 Middletown Tractor Sales
 2345 Whitehall Blvd
 Fairmont WV 26554

**DIVISION OF HIGHWAYS
 EQUIPMENT DIVISION
 ROUTE 33
 BRUSHY FORK ROAD
 BUCKHANNON, WV
 26201 304-472-1750**

DATE PRINTED	TERMS OF SALE	SHIP VIA	FOB	FREIGHT TERMS
01/16/2008	Net 30	Our Truck	Destination	Pre Paid

BID OPENING DATE: **02/13/2008** BID OPENING TIME: **01:30PM**

LINE	QUANTITY	UOP	CAT NO	ITEM NUMBER	UNIT PRICE	AMOUNT
BID OPENING TIME:				1:30 PM		
PLEASE PROVIDE A FAX NUMBER IN CASE IT IS NECESSARY TO CONTACT YOU REGARDING YOUR BID:						
				304-366-4698		
CONTACT PERSON (PLEASE PRINT CLEARLY):						
				MIKE SHAVER		
***** THIS IS THE END OF RFQ 708EC009 *****						TOTAL: See Page 21 for pricing

SEE REVERSE SIDE FOR TERMS AND CONDITIONS

SIGNATURE <i>[Signature]</i>	TELEPHONE (304) 366-4690	DATE 03-03-2008
TITLE VP	FEIN 55-0547175	ADDRESS CHANGES TO BE NOTED ABOVE

WHEN RESPONDING TO RFQ, INSERT NAME AND ADDRESS IN SPACE ABOVE LABELED 'VENDOR'

WEST VIRGINIA DEPARTMENT OF TRANSPORTATION
DIVISION OF HIGHWAYS
EQUIPMENT DIVISION

PROCUREMENT SPECIFICATIONS
NO. 021-2-C

OPEN END CONTRACT
10 FOOT OR 11 FOOT POWER REVERSIBLE SNOWPLOW (HYDRAULIC)

1.0 PURPOSE

It is the purpose of these specifications to describe a 10 Foot or 11 Foot Power Reversible Snowplow (Hydraulic) (hereinafter referred to as a "plow" or a "unit") to be purchased for use by the West Virginia Division of Highways (DOH) on an Open End Contract basis.

2.0 BIDDING PROCEDURES

The current purchasing procedures regarding bidding as established by the Department of Administration, Purchasing Division, shall apply. Failure to submit the "Request for Quotation" forms, complete in its entirety and according to directions indicated, may subject the bidder to disqualification. **Each bid submitted shall also be accompanied by a Bidder's Evaluation Report completed in detail.** Addendums in order, along with exception sheets, should be with Bidder's Evaluation Report. **FAILURE TO SUBMIT THE BIDDER'S EVALUATION REPORT, COMPLETE IN ITS ENTIRETY, MAY RESULT IN AUTOMATIC DISQUALIFICATION.**

3.0 SPECIFICATIONS

The specifications named herein, mandatory and non-mandatory, establish the acceptable level of quality only and are not intended to reflect a preference or favor any particular brand or vendor.

3.1 EXCEPTIONS TO NON-MANDATORY SPECIFICATIONS

Exception to a non-mandatory unit specification may be made by the bidder, providing the exception is not available from the manufacturer. **Any such exceptions must be noted on the bidder's evaluation report and should be accompanied by supporting documentation/literature from the manufacturer. A summary of exceptions must be prepared by vendor on a separate attachment to the bidder's evaluation report labeled as "Exception to Specifications" and should be provided with the bid.** The state reserves the right to determine whether the stated exception does or does not reduce the quality and performance of the unit. Failure to provide information for any exceptions may be grounds for rejection of the bid. The state reserves the right to waive minor irregularities in bids or specifications in accordance with §148-1-4(f) of the WV Legislative Rules and Regulations.

3.2 MANDATORY SPECIFICATIONS

All specifications preceded by "shall and/or must" or are stated as a "minimum and/or maximum" are mandatory. Any bid failing to meet any mandatory item shall be immediately disqualified. Failure to respond in the appropriate evaluation section may also be grounds for immediate disqualification at the discretion of the State.

A mandatory pre-bid conference is scheduled for this equipment purchase as stated in the RFQ. Vendors having products with variations or exceptions in specified mandatory items are expected to address any such variations or exceptions during the pre-bid conference. **The State shall review and consider any such variation or exception, and may at its sole discretion, issue an addendum to change mandatory specifications deemed to be in the State's best interest. Bids from any vendor failing to attend the mandatory pre-bid shall be disqualified. Bids containing any variation or exception to a mandatory specification that was not addressed during the pre-bid conference and accepted by the issuance of an Addendum shall be disqualified.**

4.0 REPRESENTATIVE UNIT FOR TEST

The successful vendor must (if specified) provide DOH one (1) completed representative unit to be observed and evaluated on each order to insure compliance with specification. If requested, the time period for testing and evaluation shall be seven (7) working days following receipt of the unit. DOH will incur no obligation for deterioration of surfaces, finishes, seals, and mechanical or electrical parts on the unit resulting from operation and testing within the limits of these specifications; nor will DOH incur obligation for damage to the unit resulting from failure to meet specifications when due care and attention is given by DOH and testing is done within the limits of these specifications. Failure of the pilot unit to satisfactorily meet specifications as bid shall be cause for cancellation of the purchase order, and return of the delivered unit along with all associated equipment to the vendor at the vendor's expense.

4.1 CONDITION OF UNIT(S) UPON DELIVERY

All units must arrive at the prescribed delivery point having been completely preserviced with oil, lubricants, and coolant. All prescribed precautions pertaining to first operations and break-in of the unit are to be posted conspicuously on the unit for ready observance by the operator.

4.2 DELIVERY

Delivery point of the completely assembled representative unit will be the DOH, Equipment Division, Route 33 at Brushy Fork Road, Buckhannon, West Virginia (26201).

The vendor is responsible for guaranteeing delivery of the completed units within the time specified and agreed to by the State. Delivery is preferred within 135 days after receipt of purchase agreement. The vendor is responsible for establishing and

coordinating delivery terms with allied manufacturers or suppliers. **Delivery terms shall be stated in the bid and the State reserves the right to accept or negotiate such terms.** Failure to reach an agreement may result in rejection of the bid. **The successful bidder shall provide their manufacturer's confirmation of the order to the WVDOH contact person within seven (7) working days after receiving the approved purchase order.**

A completed pilot model for inspection must be provided within 45 calendar days after receipt of the purchase agreement by the successful vendor.

Delivery is an integral part of this specification and failure to comply will be cause to initiate a D.O.T. Administrative Form WV-82, Vendor Performance Form. The WV-82 Form will provide a means of officially notifying the Purchasing Division and the vendor of unsatisfactory performance; such as late deliveries, poor service, inadequate parts supplies, etc.

The decision to initiate subject Form will be at the sole discretion of the D.O.H. Commissioner's established Equipment Review Board.

Issuance of the WV-82 Vendor Complaint Form on unsatisfactory delivery against any vendor will be cause to refuse to consider similar items from those vendors on future Request For Quotations.

(NOTE: Delivery time could be altered due to labor strikes, severe inclement weather conditions, etc.)

5.0 AWARD CRITERIA

- 5.1 DOH will recommend the award in accordance with the RFQ evaluation criteria described in the requisition. **The award shall be made to the lowest unit cost vendor that meets or exceeds the specifications.**

Prices for the units shall be in quantities of 1-10, 11-20, 21-30, 31-40, 41-50, and 51 and over. However, for evaluation purposes, we will use quantities 1-10. DOH reserves the right to place multiple orders in any quantity.

6.0 SPECIFICATIONS AND GUIDELINES - GENERAL

6.1 IDENTIFICATION OF THE UNIT BEING PROPOSED

The bidder must identify the unit by manufacturer, model, series, and year of manufacture, in the bid to enable identification by DOH in the manufacturer's specifications of the proposed unit. The bidder will submit complete descriptive literature of the proposed unit, to establish that the bid is the manufacturer's most current model, including latest engineering improvements, which have been, or will imminently be, regularly advertised and sold on the open market. The unit specified herein and offered to be manufactured after January 1, 2008 and be clearly identified and marked with date of manufacture.

6.2 OPERATING AND SERVICE MANUALS AND PARTS LISTS

An operator's manual must be included with each unit upon delivery. A "line sheet" (if applicable) and Equipment Preventative Maintenance Questionnaire (as shown in X6.2 of the Bidder's Evaluation Report) must be with pilot unit upon delivery. In addition, there must be 12 service, shop, or maintenance manuals; ten (10) to be distributed to the Districts and two (2) for the Equipment Division. Also, there must be 14 parts manuals; ten (10) to be distributed to the Districts and four (4) for Equipment Division use. CD ROM is preferred in lieu of parts manuals.

*** NOTE: MANUALS SHALL BE DELIVERED UPON COMPLETION OF DELIVERY OF TOTAL UNITS. FAILURE TO DO SO WILL DELAY PAYMENT.**

6.3 TRAINING:

Manufacturers and/or dealers will be required to stage a thorough seminar on the subjects of Preventative Maintenance, Operator and Mechanic Training. In order to keep the operators and mechanics updated, the successful vendor shall conduct training with each purchase order against this open end contract. Training is preferred within 2 working days after delivery of the pilot unit on the individual purchase order.

Manufacturers and/or dealers shall be required to furnish the Training Academy with one (1) Operator's Manual to be shipped direct to WVDOH Training Academy, Post Office Box 610, Buckhannon, West Virginia 26201 prior to delivery of the pilot.

The seminar to be held at the W. Va. Division of Highways, Equipment Division, Buckhannon, West Virginia.

6.4 PREVENTIVE MAINTENANCE AND OPERATOR PROCEDURES:

Manufacturers and/or dealers will be required to submit to the Equipment Division, in addition to the operating and service manuals, booklets and pamphlets explaining the Preventive Maintenance and Operator Procedures to be used by the operators of this equipment, and must include such things as daily prestart inspection procedure, service schedule, and routine maintenance required, safety precautions, etc.

The successful vendor shall furnish all training aids; i.e., videos, projectors, etc. required in conducting the training.

6.5 WARRANTY AND SERVICE POLICY

The Manufacturers warranty or service policy is to apply to the unit. Such warranty or service policy is to be recognized at any authorized unit dealer, representing manufacturer of proposed unit throughout the State of West Virginia. The applicable warranty or service policy will not be contingent upon obtaining routine service, lubrication, and servicing of the unit from factory authorized agencies. It will be the

responsibility of the bidder to have available labor to repair or replace any defective replacement parts, components and materials, and to have available those replacement parts, components, and/or materials found to be defective during the terms of the warranty period. The bidder should state the labor rates, locations where parts will be stocked, availability of parts, and discounts offered for parts, when terms of the warranty offer a pro-rated cost for parts and labor. In addition, the successful bidder should offer field work to repair or replace defective parts, components, and materials found to be defective during the terms of the warranty and should provide mechanic's travel rates, mileage charges, field mechanic rates, and any surcharge for miscellaneous items, if applicable, for field work during the warranty period. Submit to Division of Highways any technical or engineering improvements during the term of the warranty. **The unit must be accompanied upon delivery by the unit's manufacturer's executed warranty or service policy.**

A mandatory minimum two (2) year bumper to bumper basic parts and labor warranty is required for this unit.

THE "WARRANTY AND SERVICE POLICY QUESTIONNAIRE" ATTACHED IN THE BIDDER'S EVALUATION REPORT MUST BE COMPLETED IN ITS ENTIRETY AND SUBMITTED WITH YOUR BID. (SEE SECTION X6.5 OF BIDDER'S EVALUATION REPORT).

6.6 EVALUATION COMMITTEE REQUIREMENTS

Detailed component specifications, product literature, component models, required for specification compliance determination by the Evaluation Committee should be provided with each bid. Any information supplied that is contrary to/or conflicting with the specifications and/or attached Bidders Evaluation Report may be sufficient cause for rejection of bid.

6.7 UNSPECIFIED ACCESSORIES & FEATURES

All parts, equipment, accessories, material, design and performance characteristics not specified herein, but which are necessary to provide a complete unit, must be furnished with each unit and required to conform to strength, quality of material, and quality of workmanship to those which are advertised and provided to the market in general by the unit industry.

All parts and accessories advertised and regularly supplied as standard shall be included, except those which would represent duplication of these specified, and except those which, by specification, are not to be furnished. All standard safety features, required by Federal and State Law, shall be included.

7.0 SPECIFICATIONS OF THE QUOTED UNIT ARE AS FOLLOWS:

The hydraulically reversible snowplow to be designed for mounting on a single axle or tandem dump truck. The snowplow to be capable of plowing to the right or left at an angle of approximately thirty-five degrees (35°) discharging snow to the right or left. It should have a center mounted trip spring leaving the plow area outside the reversing arc free for nesting close to the pushing vehicle. It should be a straight blade type with an integral type snow shield.

The hydraulic power for lifting and reversing will be supplied by the truck central hydraulic system; however, **the vendor shall supply the hose and fittings to connect both systems to the valve located under the front bumper.**

The blade to be the sectional type, made up of three (3) and four (4) foot sections to total 10 feet or 11 feet wide, having a tungsten carbide inserted cutting edge.

The snowplow to be a Valk RV1142 Reversible Snowplow or equal.

7.1 Moldboard:

7.1.1 Overall Width:

7.1.1.1 **OPTION #1 - 10 Foot**

7.1.1.2 **OPTION #2 - 11 Foot**

7.1.2 Overall Height: 42 Inches

7.1.3 **Moldboard Construction: 10 US GA. Steel minimum**

7.1.4 **Travel Arc: Thirty-five degrees (35°) minimum each way; total seventy degrees (70°).**

7.1.5 Moldboard eighteen (18) inch deep radius from leading edge to deepest part of moldboard face, resulting in approximately twenty-seven degree (27°) cutting edge angle from vertical.

7.1.6 Weight of Plow: 10 foot - 2000 pounds 11 foot - 2100 pounds

7.1.7 **Vertical Ribs: Minimum of six (6) vertical ribs, ½" by 3" formed steel with two (2) ribs at each hinge point.**

7.1.8 Snow Shield: An additional rubber snow shield to be provided. It should be approximately 5/16" x 12" belting and run the entire length of plow. Mounted in such a manner as not to add to overall plow height.

- 7.1.9 **To be reinforced with a minimum of six (6) vertical ribs** and approximately five (5) horizontal ribs, or reinforcing of equivalent strength, constructed of steel and spaced per manufacturer's heavy duty design.
- 7.1.10 To be reinforced at the top and bottom edges. Top of the moldboard to be reinforced with an integrally formed channel and the bottom to have a back up angle of not less than 4" x 3" x ½" angle gusseted.
- 7.2 Cutting Edge:
- 7.2.1 **The cutting edge shall be sectioned, standard AASHO punched, in three (3) foot and four (4) foot lengths.**
- 7.2.2 Blade Sections:
- 7.2.2.1 To be **minimum ½ inch thick by six (6) inches wide** having a GRADE WC cemented tungsten carbide insert of approximately 88 Rockwell A scale hardness.
- 7.2.2.2 The insert to be silver soldered on all sides of a milled slot near the center of the working edge.
- 7.2.2.3 The braze joint to have a transverse rupture strength of **345,000 PSI minimum**
- 7.2.2.4 **Blade section must be identifiable by manufacturer, name and part number stamped on the reverse side of each section.**
- 7.2.2.5 Wrap around curb guards to be mounted right and left side of plow
- 7.2.2.6 Curb guards to be 5/8 inch thick, approximately 6 inches high, and 8 inches long
- 7.3 Safety Trip Mechanism:
- 7.3.1 **Tripping mechanism must be attached to the trunnion on the semi-circle and should be fully enclosed.**
- 7.3.2 Springs: Dual enclosed cylinder type trip springs approximately 5/8" wire 6" diameter.
- 7.3.3 **Tripping mechanism shall be equipped with external cushion spring for absorbing shock when moldboard returns to normal plowing position.**
- 7.3.4 **The trip mechanism must hold the plow rigid in the plowing position and trip automatically when the cutting edge comes in contact with an obstruction then return to normal plowing position.**
- 7.4 Push Frame:
- 7.4.1 **Push frame shall be of all welded construction designed per manufacturer's heavy duty specifications.**

- 7.4.2 Moldboard to push frame connection to be by a **minimum of three (3) hinges.**
- 7.4.3 **The plow push frame shall be equipped with an oscillating feature to permit the plow to follow uneven road surfaces.**
 - 7.4.3.1 **Push frame shall be equipped with a quick hitch connection system.**
- 7.4.4 Hydraulic Power Reversing Mechanism:
 - 7.4.4.1 To consist of two (2) double acting positive locking power reversing hydraulic cylinders fitted with the fixed base end in the center of the push frame.
 - 7.4.4.2 The cylinders to be approximately four (4) inches inside diameter and to be piped to utilize power of both cylinders on every turn.
 - 7.4.4.3 **Hydraulic power reverse mechanism shall include a dual cross-over relief cushion valve rated at a minimum of 40 G.P.M.**
- 7.4.5 Skid Shoes:
 - 7.4.5.1 Caster mounted carbide mushroom type shoes, **one (1) each side shall be provided.**
 - 7.4.5.2 **Manufacturer's standard adjusting mechanism shall be included.**
- 7.5 Hitch:
 - 7.5.1 Designed as a universal heavy duty type unit to carry plows of weight specified when mounted on **32,000 pound class trucks minimum.**
 - 7.5.2 **The hitch shall be a bumper to axle type universally adaptable to any conventional truck and to accommodate the tilt front end on the carrier.**
 - 7.5.2.1 **Hitch shall be manufacturers quick hitch connection system for easy hook and unhook from plow push frame.**
 - 7.5.2.2 Hitch to include a lift system designed at a **rated capacity of 8,000 lbs minimum.**
 - 7.5.3 Hitch to Bumper Attachment:
 - 7.5.3.1 To be made by bolting approximately $\frac{1}{2}$ " x $2\frac{1}{2}$ " x 6" x 45" piece of steel angle to the channel bumper.
 - 7.5.3.2 Approximately six (6) inch flange is vertical on front of the bumper with approximately two and one-half ($2\frac{1}{2}$) inch flange resting on top.

- 7.5.3.3 Ears or lugs must be welded to the vertical plane of the angle to facilitate attachment of the main body of the hitch.
- 7.5.3.4 The axle end of the hitch shall be attached to the front axle by means of clamping arrangement.
- 7.5.3.5 The axle clamp must allow longitudinal motion but not vertical and horizontal motion so as to stabilize the hitch.
- 7.5.4 The horizontal and vertical frames shall be constructed of four (4) inch structural steel "H" beams or equal, properly gusseted and welded.
- 7.6 Hydraulic System: Hydraulic pressure will be supplied from the truck central hydraulic system through a lift valve and reversing valve (main bank valve) to the plow lift and reversing cylinders. **The vendor shall be required to supply the following hydraulic components:**
 - 7.6.1 One (1) 3" lift cylinder with 10" stroke double-acting hydraulic lift cylinder (even if we only use one (1) line fitting in upper end with breather), clevis pinned top and bottom.
 - 7.6.2 Two (2) four (4) inch double acting hydraulic reversing cylinders
 - 7.6.3 Three (3) pieces of two (2) wire hydraulic pressure hose one-quarter (1/4) inch diameter and approximately ten (10) feet long. Each hose must be equipped with:
 - 7.6.3.1 One (1) quick coupler at plow end with dust caps. Prefer Snap-Tite Couplers VHN-8 Nipple Hose, VHN-8 Nipple Reverse Cylinder, VHC-8 Nipple Reverse Cylinder 90° Fitting.
 - 7.6.3.2 Two (2) crimp-type hose fittings with male JIC 370 threads. One (1) to mate with swivel and the other to mate with quick coupler.
 - 7.6.3.3 One (1) JIC 370 - swivel - 90°elbow/male JIC 370.
 - 7.6.3.4 One (1) adaptor to mate bank valve port to JIC swivel.
- 7.7 Unit shall include all other features considered as standard equipment but not specifically addressed above.
- 7.8 Vendor must certify that snowplow offered will comply with Occupational Safety and Health Act of 1970 and subsequent amendments.

- 7.9 It is the intention of the West Virginia Division of Highways to secure a close fitting, simple, reversible snowplow that will be designed to operate as close as possible to the vehicle pushing it, to maintain truck balance within reasonable limits.

Key features for acceptability will be a relatively light weight compact unit. Lift by cable acceptable providing side shifting of cable is not impeded by lift point device.

Vendors are cautioned that a push frame and/or hitch assembly designed without regard to overall distance of truck to front of plow which would jeopardize truck balance may be judged as not conforming to these specifications.

- 7.10 Paint: The entire unit to be painted in accordance with West Virginia Division of Highways requirements as follows:

- 7.10.1 The entire unit to be sandblasted and thoroughly cleaned, free of rust, grease, and scale.
- 7.10.2 The complete assembly to receive one (1) coat of metal sealer primer.
- 7.10.3 The front of the plow to be given one (1) undercoat and one (1) finish coat of Federal Yellow (No. 93-6578) DuPont Deluxe equipment enamel or equal quality paint of other manufacturer.
- 7.10.4 The rear of the plow to be given one (1) undercoat and one (1) finish coat of manufacturer's standard Black (Flat) equipment enamel.
- 7.10.5 The push frame and hitch to be given one (1) undercoat and one (1) finish coat of Martin Senour Dark Red Blue, #99N38076 or equal. **Complete coverage of the push frame and hitch is mandatory.**

- 7.11 **Advertising: Manufacturer shall attach a metal plate on the reverse side of moldboard stating manufacturer, series or model number, size and type of blade (approximately six (6) inch to eight (8) inch square). Date of manufacture shall also be stamped on the plate or the moldboard. No large decals or painted advertisement are permitted.**

- 7.12 All loose hardware to be in a separate container for each plow and shipped with each plow.

WEST VIRGINIA DEPARTMENT OF TRANSPORTATION
DIVISION OF HIGHWAYS
EQUIPMENT DIVISION

BIDDER'S EVALUATION REPORT

PROCUREMENT SPECIFICATIONS
NO. 021-2-C

OPEN END CONTRACT
10 FOOT OR 11 FOOT POWER REVERSIBLE SNOWPLOW (HYDRAULIC)

NOTE TO BIDDER: Procurement Specification No. 021-2-C, Paragraph 2.0 recommends the completion and submittal of this Report with your bid. Purpose of this Report is to enable the West Virginia Division of Highways Evaluation Committee to make full and fair evaluation of the bid. Addendums in order, along with a summary of exception as a separate attachment, should be with Bidder's Evaluation Report.
FAILURE TO SUBMIT THIS REPORT, COMPLETE IN ITS ENTIRETY, MAY SUBJECT THE BIDDER TO DISQUALIFICATION.

Reference Requisition No.: 708EC009

Bidder's Name: Middletown Tractor Sales

Address: 2345 Whitehall Blvd Fairmont WV 26554

Telephone Number: (304)366-4690

Years Bidder has been registered to do business with the State of West Virginia: 35 YRS.

Years Company has been an authorized dealer for proposed unit: 1 YRS.

X3.2 Have you complied with all mandatory specifications? YES NO

X4.2 DELIVERY:

X4.2.1 Delivery date of completed representative unit: 45 Calendar Days After
Receipt of Purchase Agreement

X4.2.2 Delivery date of balance of completed units: 150 Calendar Days After Receipt of
Purchase Agreement

X5.0 AWARD CRITERIA;

OPTION #1 - 10 FOOT

X5.1 Prices for plows in quantities of

1-10	<u>\$6,316.00</u>	per unit
11-20	<u>\$6,961.00</u>	per unit
21-30	<u>\$6,961.00</u>	per unit
31-40	<u>\$6,961.00</u>	per unit
41-50	<u>\$6,961.00</u>	per unit
51 and over	<u>\$6,961.00</u>	per unit

OPTION #2 - 11 FOOT

X5.1 Prices for plows in quantities of

1-10	<u>\$6,478.00</u>	per unit
11-20	<u>\$7,143.00</u>	per unit
21-30	<u>\$7,143.00</u>	per unit
31-40	<u>\$7,143.00</u>	per unit
41-50	<u>\$7,143.00</u>	per unit
51 and over	<u>\$7,143.00</u>	per unit

X6.0 SPECIFICATIONS - GENERAL

X6.1 Manufacturer, model, series, and date of manufacture of proposed unit:

Monroe MP41R10-ISCT-WVA Date of manufacture-2008 or later

Monroe MP41R11-ISCT-WVA Date of manufacture-2008 or later

Is descriptive literature, fully describing proposed unit attached to your bid? YES NO

If not, why? _____

X6.2 Will the required number of service manuals, and complete parts list be delivered to the Equipment Division at Buckhannon upon completion of delivery of total units?

YES NO

Will the required Equipment Preventive Maintenance Form (Section X6.2 of Bidders Evaluation Report) be provided upon inspection of the pilot unit?

YES NO

EQUIPMENT PREVENTATIVE MAINTENANCE QUESTIONNAIRE

THIS FORM MUST BE COMPLETED IN ITS ENTIRETY BY SUCCESSFUL BIDDER OR MANUFACTURER'S TECHNICAL REPRESENTATIVE PRIOR TO DELIVERY OF PILOT MODEL TO THE WVDOH.

DESCRIPTION: _____ MAKE: _____

MODEL: _____ YEAR: _____ PURCHASE AMOUNT: _____

ENGINE: MAKE: _____ MODEL: _____ FUEL TYPE: _____

HORSEPOWER: _____ CYLINDER: _____ ENGINE SERIAL: _____

COOLING SYSTEM CAPACITY: _____

BELTS: DESCRIPTION: _____ PART NUMBERS: _____

GVW: _____ AXLE CAPACITY: FRONT: _____ REAR: _____

TIRES: FRONT MAKE & SIZE: _____

REAR MAKE & SIZE: _____

DIMENSIONS OF UNIT: LENGTH: _____ WIDTH: _____ LENGTH: _____

VENDOR CONTACT PERSON: _____ PHONE: _____

PARTS:

BATTERY MAKE: _____ MODEL: _____ CCA: _____

TOP OR SIDE POST: _____ DIMENSIONS: LENGTH _____ WIDTH _____ HEIGHT _____

SPARK PLUGS OR FUEL INJECTORS MAKE: _____ PART # _____

FUEL PUMP OR INJECTION PUMP MAKE: _____ MODEL: _____

ALTERNATOR MAKE: _____ PART #: _____

STARTER MAKE: _____ PART #: _____

TURBO CHARGER MAKE: _____ PART #: _____

TRANS. MAKE: _____ MODEL: _____ AUTO/MANUAL: _____

HYDRAULIC PUMP MAKE: _____ MODEL: _____

FILTERS	MAKE	PART NO.	LUBRICANT	MANUFACTURER TYPE
OIL	_____	_____	ENGINE	_____
AIR INNER	_____	_____	TRANSMISSION	_____
AIR OUTER	_____	_____	POWER STEERING	_____
FUEL PRIMARY	_____	_____	HYDRAULIC	_____
FUEL SECONDARY	_____	_____	DIFFERENTIALS	_____
COOLANT	_____	_____	BRAKE FLUID	_____
HYDRAULIC	_____	_____	COOLANT	_____
OTHER	_____	_____	OTHER	_____

X6.3 TRAINING:

Will training seminar be conducted on Preventive Maintenance, Operator and Mechanic Training
_____ YES _____ NO

See Addendum

Will you conduct training with each purchase order against this open end contract?
_____ YES _____ NO

See Addendum

Will training be conducted within 2 working days from the delivery of the pilot unit on the individual purchase order?
_____ YES _____ NO

If NO, explain time frame See Addendum

Will an Operator's Manual be furnished directly to Training Academy prior to the delivery of the pilot?
_____ X _____ YES _____ NO

X6.4 If you are the successful vendor, will you furnish all training aids, i.e., videos, projectors, required in conducting the training?
_____ YES _____ NO

See Addendum

X6.4.1 Will all manuals, booklets, etc. explaining preventive maintenance, operator procedures, and service schedule be delivered with each unit?
_____ X _____ YES _____ NO
If NO, explain _____

X6.5 WARRANTY AND SERVICE POLICY

Will the warranty and service you provide comply with all areas as stated in Section 6.5 of specifications
_____ X _____ YES _____ NO

Is warranty literature attached? _____ X _____ YES _____ NO

Is a minimum two (2) year bumper to bumper basic parts and labor warranty included?
_____ X _____ YES _____ NO

Describe:
See attached warranty statement

Have you completed and submitted "Warranty and Service Policy Questionnaire" with your bid?
_____ X _____ YES _____ NO

X6.5 WARRANTY AND SERVICE POLICY QUESTIONNAIRE

THIS FORM MUST BE COMPLETED IN ITS ENTIRETY AND SUBMITTED WITH YOUR BID.

(If additional lines are needed, make copies of form.)

1. Define the terms of the standard warranty. If not offered, so state. (Attach copy)

The standard warranty term as it applies to RFQ#708EC009 is two years. This is stated in detail in the warranty policy attached to the original bid. (RFQ:708EC009

2. Define warranty service to be performed at DOH facilities and warranty service to be performed at manufacturer's representative facility. List name and location of manufacturer's representative.

Warranty repair is to be performed at Middletown's Fairmont, WV location. However, Middletown Tractor Sales will perform on-site repairs if requested. Note: Service call fees of \$55.00 per hour for travel port to port are not covered by the warranty.

3. List locations for parts inventories that are within the State of West Virginia. Also, list availability levels, if known.

Parts inventories are stocked at Middletown Tractor Sales' Fairmont WV location.

4. During the term of warranty, list the guarantee discount to manufacturer's published list price for parts that bidder will sell the parts to owner.

- A. Terms: Net 30 Manufacturer's published list price less: 0 % discount
- B. Terms: Net 60 Manufacturer's published list price less: 0 % discount
- C. Terms: Net 90 Manufacturer's published list price less: 0 % discount

5. During the term of warranty, will all manufacturers or engineering improvements be submitted to Division of Highways? X YES NO

6. During the term of warranty, list the guaranteed rates charged for repair to the unit.

- A. Shop Rate \$ 51.00 per mechanic hour
- B. Travel Time Charge \$ 55.00 per mechanic hour
(Specify if one-way) _____; port to port X
- C. Mileage Charge \$ N/A per vehicle mile
(Specify if one-way) _____; port to port _____
- D. Field Mechanic Rate \$ 55.00 per mechanic hour
- E. Specify period of time that prices are in effect: Calendar year 2008 unless otherwise submitted in writing to the purchasing division
- F. Surcharge for miscellaneous items: 0 %

X6.6 EVALUATION COMMITTEE REQUIREMENTS

Is all component specifications, product literature, component models provided for Evaluation Committee bid determination? YES NO

X6.7 Will all parts, equipment, accessories, material, design and performance characteristics not specified herein, but which are necessary to provide a complete unit, be furnished with the unit and conform in strength, quality of material, and quality of workmanship to those which are advertised and provided to the market in general by the unit industry?

YES NO

X6.7.1 Are all parts and accessories adequate and regularly supplied as standard to be included except those which may be duplications of specifications herein, and except these by specification are not to be furnished?

YES NO

X6.7.2 Are all standard safety features that are required by Federal and State statutes of law included?

YES NO

X7.0 SPECIFICATIONS OF THE QUOTED UNIT

The bidder should complete the following schedule in order for the Division to compare the actual bid unit to the specifications. Should the bidder except a requirement, then such exception may be only on the basis that such feature is not offered by the manufacturer. The Division will have the sole discretion as to whether the bidder's substitution meets the requirements of the specifications. by the manufacturer. The Division will have the sole discretion as to whether the bidder's substitution meets the requirements of the specifications.

Is the snowplow designed for mounting on a single axle or tandem dump truck

YES NO

Is the snowplow capable of plowing to the right or left at an angle approximately 35° discharging to the right or left

YES NO

Does it have a center mounted trip spring leaving the plow area outside the reversing arc free for nesting close to the pushing vehicle

YES NO

Dual center springs (compression type)

Is it a straight blade type with an integral type snow shield YES NO

Will you supply the hose and fittings to connect both systems to the valve located under the front bumper

YES NO

Is the blade section type, made up of three (3) and four (4) foot sections to total 10 feet or 11 feet wide, having a tungsten carbide inserted cutting edge

YES NO

Manufacturer: Monroe

Model MP41R10-ISCT-WVA

MP41R11-ISCT-WVA

X7.1 Moldboard:

X7.1.1 Overall Width:

X7.1.1.1 **OPTION #1** – 10 Foot YES NOX7.1.1.2 **OPTION #2** – 11 Foot YES NOX7.1.2 Overall height: 39 inches To inside top of moldboard W/6" edgeX7.1.3 **Moldboard construction:** 18 U.S. GaugeX7.1.4 **Travel arc:** 35 ° each way; total 70 °X7.1.5 Radius from leading edge to deepest part of moldboard face 18 inches deep.Cutting edge angle from vertical 20 degreesX7.1.6 Weight of plow: 10 foot 2000 Lbs. 11 foot 2100 Lbs.X7.1.7 **Number of vertical ribs** 6 Formed steel 1/2" plateHow many ribs at each hinge point? 2X7.1.8 Is an additional rubber snow shield provided? YES NOSize of belting 5/16X12 Run entire length of plow? YES NOMounted so it won't add to overall height? YES NO

X7.1.9 Reinforcement constructed of steel and spaced per manufacturer's heavy duty design?

 YES NO**Number of vertical ribs:** 6 **Number of horizontal ribs:** 1X7.1.10 Reinforced at top and bottom edges? YES NOTop of moldboard reinforced with integrally formed channel? YES NOBottom back up angle 4 x 4 x 3/4 angle gusseted.

X7.2 Cutting Edge:

X7.2.1 **Sectioned, standard AASHO punched, in three (3) foot and four (4) foot lengths?** YES NO

X7.2.2 Blade Sections:

X7.2.2.1 3/4 inch thick by 6 inches wide having a Grade WC cemented tungsten carbide insert of approximately 88 Rockwell A scale hardness?

YES NO

X7.2.2.2 Insert silver soldered on all sides of a milled slot near the center of the working edge?

YES NO

X7.2.2.3 Braze joint transverse rupture strength: 350,000 PSI

X7.2.2.4 Blade section identifiable by manufacturer, name and part number stamped on the reverse side of each section?

YES NO

X7.2.2.5 Will wrap around curb guards be mounted on right and left side of plow

YES NO

X7.2.2.6 Curb guards are 5/8 inch thick, 6 inches high and 8 inches long

X7.3 Safety Trip Mechanism:

X7.3.1 Tripping mechanism attached to trunnion on semi-circle and fully enclosed? See Addendum

YES NO
 YES NO

X7.3.2 Are springs dual enclosed cylinder type trip springs? See addendum

YES NO
See addendum

719 inch wire 5.313 inch diameter

X7.3.3 Is tripping mechanism equipped with external cushion spring for absorbing shock?

YES NO

See addendum

X7.3.4 Does the trip mechanism hold the plow rigid in plowing position and trip automatically when cutting edge comes in contact with an obstruction then returns to normal plowing position?

YES NO

X7.4 Push Frame:

X7.4.1 All welded construction designed per manufacturer's heavy duty specifications?

YES NO

X7.4.2 Number of hinges in moldboard to push frame connection? 4

X7.4.3 Equipped with an oscillating feature to permit plow to follow uneven road surfaces?

YES NO

X7.4.3.1 Is push frame equipped with a quick hitch connection system?

YES NO

X7.4.4 Hydraulic Power Reversing Mechanism:

X7.4.4.1 Consist of two (2) double acting positive locking power reversing hydraulic cylinders fitted with the fixed base end in the center of the push frame? YES NO

X7.4.4.2 Cylinders four (4) inches inside diameter and piped to utilize power of both cylinders on every turn? YES NO

X7.4.4.3 Does hydraulic power reverse mechanism include a dual cross-over relief cushion valve?
 YES NO
 Rated at 30 GPM

X7.4.5 Skid Shoes:

X7.4.5.1 Are caster mounted carbide mushroom type shoes included? YES NO

One on each side YES NO

X7.4.5.2 Manufacturer's standard adjusting mechanism included? YES NO

X7.5 Hitch:

X7.5.1 Universal heavy duty type designed to carry plows of weight specified when mounted on a 32,000 pound class truck minimum? YES NO

X7.5.2 Bumper to axle type universally adaptable to any conventional truck and to accommodate a tilt front end on the carrier? YES NO

X7.5.2.1 Is hitch manufacturers quick hitch connection system for easy hook and unhook from plow push frame? YES NO

X7.5.2.2 Does hitch include a lift system YES NO

Designed at a rated capacity of 8000 lbs.

X7.5.3 Hitch to Bumper Attachment:

X7.5.3.1 Size of steel angle bolted to the channel bumper? 1/2x4"x6"x48"

X7.5.3.2 Size of vertical flange on front of bumper? 6" Inches

Size of flange resting on top 4 Inches

X7.5.3.3 Ears or lugs welded to the vertical plane of the angle to facilitate attachment of the main body of the hitch? YES NO

X7.5.3.4 Axle end of hitch attached to the front axle by means of clamping arrangement? YES NO

X7.5.3.5 Axle clamp allows longitudinal motion but not vertical and horizontal motion? YES NO

X7.5.4 Are the horizontal and vertical frames constructed of four (4) inch structural steel "H" beams or equal and properly gusseted and welded? YES NO

X7.6 Hydraulic System:
Will you supply the following hydraulic components YES NO

X7.6.1 Provide one (1) 3" lift cylinder with 10" stroke double-acting hydraulic lift cylinder, clevis pinned top and bottom? YES NO

X7.6.2 Provide two (2) four (4) inch double acting hydraulic reversing cylinders? YES NO

X7.6.3 Provide three (3) pieces of two (2) wire hydraulic pressure hose one-quarter (1/4) inch diameter by approximately ten (10) feet long? YES NO

Is each hose equipped with the following YES NO

X7.6.3.1 Each hose equipped with one (1) quick coupler at plow end with dust cap? YES NO

Manufacturer/Model: Snap Tite Per Spec

X7.6.3.2 Each hose equipped with two (2) crimp-type fittings with male JIC 370 threads (one (1) to mate with swivel and the other to mate with quick coupler)? YES NO

X7.6.3.3 Each hose equipped with one (1) JIC 370 - swivel - 90°elbow/male JIC 370? YES NO

X7.6.3.4 Each hose equipped with one (1) adaptor to mate bank valve port to JIC swivel? YES NO

X7.7 Other Standard Features:

List other standard features offered and not addressed above:

X7.8 Does the proposed unit meet or exceed the OSHA of 1970 and/or subsequent changes? YES NO

X7.9 Is push frame and/or hitch assembly designed with regard to overall distance of truck to front of plow which would jeopardize truck balance? YES NO

X7.10 Paint:

X7.10.1 – X7.10.4 Describe proposed method of painting the unit: ~~Shot blasted, cleansed in a 5 stage washer to remove oil and dirt, and a powder coat painting process with a cure of 375degrees for 23 minutes.~~

Will unit be sandblasted prior to painting? YES NO

X7.10.5 Paint and undercoat for push frame and hitch All colors as per spec.

Will push frame and hitch be completely covered YES NO

X7.11 Does the unit conform to the advertising guidelines? YES NO

X7.12 Will all loose hardware be in separate containers for each plow and be shipped with each plow? YES NO

STATE OF WEST VIRGINIA
Purchasing Division

PURCHASING AFFIDAVIT

West Virginia Code §5A-3-10a states: No contract or renewal of any contract may be awarded by the state or any of its political subdivisions to any vendor or prospective vendor when the vendor or prospective vendor or a related party to the vendor or prospective vendor is a debtor and the debt owed is an amount greater than one thousand dollars in the aggregate

DEFINITIONS:

"Debt" means any assessment, premium, penalty, fine, tax or other amount of money owed to the state or any of its political subdivisions because of a judgment, fine, permit violation, license assessment, defaulted workers' compensation premium, penalty or other assessment presently delinquent or due and required to be paid to the state or any of its political subdivisions, including any interest or additional penalties accrued thereon.

"Debtor" means any individual, corporation, partnership, association, limited liability company or any other form or business association owing a debt to the state or any of its political subdivisions. "Political subdivision" means any county commission; municipality; county board of education; any instrumentality established by a county or municipality; any separate corporation or instrumentality established by one or more counties or municipalities, as permitted by law; or any public body charged by law with the performance of a government function or whose jurisdiction is coextensive with one or more counties or municipalities. "Related party" means a party, whether an individual, corporation, partnership, association, limited liability company or any other form or business association or other entity whatsoever, related to any vendor by blood, marriage, ownership or contract through which the party has a relationship of ownership or other interest with the vendor so that the party will actually or by effect receive or control a portion of the benefit, profit or other consideration from performance of a vendor contract with the party receiving an amount that meets or exceeds five percent of the total contract amount.

EXCEPTION: The prohibition of this section does not apply where a vendor has contested any tax administered pursuant to chapter eleven of this code, workers' compensation premium, permit fee or environmental fee or assessment and the matter has not become final or where the vendor has entered into a payment plan or agreement and the vendor is not in default of any of the provisions of such plan or agreement.

LICENSING: Vendors must be licensed and in good standing in accordance with any and all state and local laws and requirements by any state or local agency of West Virginia, including, but not limited to, the West Virginia Secretary of State's Office, the West Virginia Tax Department, West Virginia Insurance Commission, or any other state agencies or political subdivision. Furthermore, the vendor must provide all necessary releases to obtain information to enable the Director or spending unit to verify that the vendor is licensed and in good standing with the above entities.

CONFIDENTIALITY: The vendor agrees that he or she will not disclose to anyone, directly or indirectly, any such personally identifiable information or other confidential information gained from the agency, unless the individual who is the subject of the information consents to the disclosure in writing or the disclosure is made pursuant to the agency's policies, procedures and rules. Vendors should visit www.state.wv.us/admin/purchase/privacy for the Notice of Agency Confidentiality Policies.

Under penalty of law for false swearing (West Virginia Code, §61-5-3), it is hereby certified that the vendor acknowledges the information in this said affidavit and are in compliance with the requirements as stated.

Vendor's Name: Middletown Tractor Sales

Authorized Signature: J. Adam Boyer, VP

Date: 3/3/08



State of West Virginia
 Department of Administration
 Purchasing Division
 2019 Washington Street East
 Post Office Box 50130
 Charleston, WV 25305-0130

Request for Quotation

RFQ NUMBER
708EC009

PAGE
1

ADDRESS CORRESPONDENCE TO ATTENTION OF
MICHAEL AUSTIN
304-558-2402

RFQ COPY

TYPE NAME/ADDRESS HERE

Middletown Tractor Sales
 2345 Whitehall Blvd
 Fairmont WV 26554

DIVISION OF HIGHWAYS
EQUIPMENT DIVISION
ROUTE 33
BRUSHY FORK ROAD
BUCKHANNON, WV
26201 **304-472-1750**

DATE PRINTED	TERMS OF SALE	SHIP VIA	F.O.B.	FREIGHT TERMS
02/11/2008	Net 30	Our Truck	Destination	Prepaid
BID OPENING DATE: 02/13/2008		BID OPENING TIME 01:30PM		

LINE	QUANTITY	UOP	CAT. NO.	ITEM NUMBER	UNIT PRICE	AMOUNT
ADDENDUM NO. 1						
BID OPENING DATE AND TIME CHANGED						
FROM: 02/13/08 AT 1:30 P.M.						
TO: POSTPONE UNTIL FURTHER NOTICE						
NO OTHER CHANGES						
0001	1	EA		765-61		
SNOWPLOW(HYDRAULIC)						
***** THIS IS THE END OF RFQ 708EC009 *****						TOTAL: See page 21 of the original bid for pricing

SEE REVERSE SIDE FOR TERMS AND CONDITIONS

SIGNATURE <i>[Signature]</i>	TELEPHONE (304) 366-4690	DATE 03-03-2008
TITLE VP	FEIN 55-0547175	ADDRESS CHANGES TO BE NOTED ABOVE

WHEN RESPONDING TO RFQ, INSERT NAME AND ADDRESS IN SPACE ABOVE LABELED 'VENDOR'

**GENERAL TERMS & CONDITIONS
REQUEST FOR QUOTATION (RFQ) AND REQUEST FOR PROPOSAL (RFP)**

1. Awards will be made in the best interest of the State of West Virginia.
2. The State may accept or reject in part, or in whole, any bid.
3. All quotations are governed by the *West Virginia Code* and the *Legislative Rules* of the Purchasing Division.
4. Prior to any award, the apparent successful vendor must be properly registered with the Purchasing Division and have paid the required \$125.00 registration fee.
5. All services performed or goods delivered under State Purchase Orders/Contracts are to be continued for the term of the Purchase Order/Contract, contingent upon funds being appropriated by the Legislature or otherwise being made available. In the event funds are not appropriated or otherwise available for these services or goods, this Purchase Order/Contract becomes void and of no effect after June 30.
6. Payment may only be made after the delivery and acceptance of goods or services.
7. Interest may be paid for late payment in accordance with the *West Virginia Code*.
8. Vendor preference will be granted upon written request in accordance with the *West Virginia Code*.
9. The State of West Virginia is exempt from federal and state taxes and will not pay or reimburse such taxes.
10. The Director of Purchasing may cancel any Purchase Order/Contract upon 30 days written notice to the seller.
11. The laws of the State of West Virginia and the *Legislative Rules* of the Purchasing Division shall govern all rights and duties under the Contract, including without limitation the validity of this Purchase Order/Contract.
12. Any reference to automatic renewal is hereby deleted. The Contract may be renewed only upon mutual written agreement of the parties.
13. **BANKRUPTCY:** In the event the vendor/contractor files for bankruptcy protection, this Contract may be deemed null and void, and terminated without further order.
14. **HIPAA Business Associate Addendum -** The West Virginia State Government HIPAA Business Associate Addendum (BAA), approved by the Attorney General, and available online at the Purchasing Division's web site (<http://www.state.wv.us/admin/purchase/vrc/hipaa.htm>) is hereby made part of the agreement. Provided that, the Agency meets the definition of a Covered Entity (45 CFR §160.103) and will be disclosing Protected Health Information (45 CFR §160.103) to the vendor.

INSTRUCTIONS TO BIDDERS

1. Use the quotation forms provided by the Purchasing Division.
2. **SPECIFICATIONS:** Items offered must be in compliance with the specifications. Any deviation from the specifications must be clearly indicated by the bidder. Alternates offered by the bidder as **EQUAL** to the specifications must be clearly defined. A bidder offering an alternate should attach complete specifications and literature to the bid. The Purchasing Division may waive minor deviations to specifications.
3. Complete all sections of the quotation form.
4. Unit prices shall prevail in cases of discrepancy.
5. All quotations are considered F.O.B. destination unless alternate shipping terms are clearly identified in the quotation.
6. **BID SUBMISSION:** All quotations must be delivered by the bidder to the office listed below prior to the date and time of the bid opening. Failure of the bidder to deliver the quotations on time will result in bid disqualifications.

SIGNED BID TO:

Department of Administration
Purchasing Division
2019 Washington Street East
Post Office Box 50130
Charleston, WV 25305-0130

SIGN-IN SHEET

RFQ # 708EC009

Date: 01/31/2008

Firm & Representative Name:	Mailing Address:	Phone, Fax, & E-Mail:
1. <u>LEN HANCOCK</u>	<u>1825 EARL CORE RD.</u>	P <u>292 1307</u>
<u>LH JONES EQUIP.</u>	<u>MORGANTOWN, WV 26505</u>	F <u>292 6641</u>
		E-mail <u>LEN@LHJONES.COM</u>

2. <u>MARY GRAHAM</u>	<u>HEVENWORTH, KS</u>	P _____
<u>HENKE MFG.</u>	_____	F _____
		E-mail _____

3. <u>MIKE SHAWER</u>	<u>2032 FAIRMONT AVE</u>	P <u>304-366-4690</u>
<u>MIDDLETOWN TRACTOR</u>	<u>FAIRMONT WV 26554</u>	F <u>304-366-4698</u>
		E-mail <u>MIKE@MIDDLETOWNTRACTOR.COM</u>

4. <u>WV TRACTOR</u>	<u>P.O. BOX 473</u>	P <u>304-346-5301</u>
<u>GARY GRADY</u>	<u>CHARLESTON WV</u>	F <u>304-346-5305</u>
	<u>25322</u>	E-mail <u>WVTRACTOR@MSN.COM</u>

5. _____	_____	P _____
_____	_____	F _____
		E-mail _____

Please print or write legibly!

Your fax # is essential to contact you timely!



State of West Virginia
 Department of Administration
 Purchasing Division
 2019 Washington Street East
 Post Office Box 50130
 Charleston, WV 25305-0130

Request for Quotation

RFQ NUMBER
708EC009

PAGE
1

ADDRESS CORRESPONDENCE TO ATTENTION OF
MICHAEL AUSTIN
304-558-2402

RFQ COPY

TYPE NAME/ADDRESS HERE
 Middletown Tractor Sales
 2045 Whitehall Blvd
 Armont WV 26554

DIVISION OF HIGHWAYS
EQUIPMENT DIVISION
ROUTE 33
BRUSHY FORK ROAD
BUCKHANNON, WV
26201 **304-472-1750**

DATE PRINTED	TERMS OF SALE	SHIP VIA	FOB	FREIGHT TERMS
02/25/2008	Net 30	Our Truck	Destination	Pre paid
BID OPENING DATE: 03/05/2008		BID OPENING TIME 01:30PM		

LINE	QUANTITY	UOP	CAT NO	ITEM NUMBER	UNIT PRICE	AMOUNT
ADDENDUM NO. 2						
CHANGES TO THE SPECIFICATIONS PER THE ATTACHED.						
BID OPENING DATE AND TIME CHANGED						
FROM: POSTPONE UNTIL FURTHER NOTICE						
TO: 03/05/08 AT 1:30 P.M.						
NO OTHER CHANGES.						
0001	1	EA		765-61		
SNOWPLOW (HYDRAULIC)						
***** THIS IS THE END OF RFQ 708EC009 ***** TOTAL:						
						See page 21 of original bid for pricing.

SEE REVERSE SIDE FOR TERMS AND CONDITIONS

SIGNATURE <i>J.A. Boyer</i>	TELEPHONE (304) 366-4690	DATE 03-03-2008
TITLE VP	FAX 55-0547175	ADDRESS CHANGES TO BE NOTED ABOVE

WHEN RESPONDING TO RFQ, INSERT NAME AND ADDRESS IN SPACE ABOVE LABELED 'VENDOR'

**GENERAL TERMS & CONDITIONS
REQUEST FOR QUOTATION (RFQ) AND REQUEST FOR PROPOSAL (RFP)**

1. Awards will be made in the best interest of the State of West Virginia.
2. The State may accept or reject in part, or in whole, any bid.
3. All quotations are governed by the *West Virginia Code* and the *Legislative Rules* of the Purchasing Division.
4. Prior to any award, the apparent successful vendor must be properly registered with the Purchasing Division and have paid the required \$125.00 registration fee.
5. All services performed or goods delivered under State Purchase Orders/Contracts are to be continued for the term of the Purchase Order/Contract, contingent upon funds being appropriated by the Legislature or otherwise being made available. In the event funds are not appropriated or otherwise available for these services or goods, this Purchase Order/Contract becomes void and of no effect after June 30.
6. Payment may only be made after the delivery and acceptance of goods or services.
7. Interest may be paid for late payment in accordance with the *West Virginia Code*.
8. Vendor preference will be granted upon written request in accordance with the *West Virginia Code*.
9. The State of West Virginia is exempt from federal and state taxes and will not pay or reimburse such taxes.
10. The Director of Purchasing may cancel any Purchase Order/Contract upon 30 days written notice to the seller.
11. The laws of the State of West Virginia and the *Legislative Rules* of the Purchasing Division shall govern all rights and duties under the Contract, including without limitation the validity of this Purchase Order/Contract.
12. Any reference to automatic renewal is hereby deleted. The Contract may be renewed only upon mutual written agreement of the parties.
13. **BANKRUPTCY:** In the event the vendor/contractor files for bankruptcy protection, this Contract may be deemed null and void, and terminated without further order.
14. **HIPAA Business Associate Addendum -** The West Virginia State Government HIPAA Business Associate Addendum (BAA), approved by the Attorney General, and available online at the Purchasing Division's web site (<http://www.state.wv.us/admin/purchase/vrc/hipaa.htm>) is hereby made part of the agreement. Provided that, the Agency meets the definition of a Covered Entity (45 CFR §160.103) and will be disclosing Protected Health Information (45 CFR §160.103) to the vendor.

INSTRUCTIONS TO BIDDERS

1. Use the quotation forms provided by the Purchasing Division.
2. **SPECIFICATIONS:** Items offered must be in compliance with the specifications. Any deviation from the specifications must be clearly indicated by the bidder. Alternates offered by the bidder as **EQUAL** to the specifications must be clearly defined. A bidder offering an alternate should attach complete specifications and literature to the bid. The Purchasing Division may waive minor deviations to specifications.
3. Complete all sections of the quotation form.
4. Unit prices shall prevail in cases of discrepancy.
5. All quotations are considered F.O.B. destination unless alternate shipping terms are clearly identified in the quotation.
6. **BID SUBMISSION:** All quotations must be delivered by the bidder to the office listed below prior to the date and time of the bid opening. Failure of the bidder to deliver the quotations on time will result in bid disqualifications.

SIGNED BID TO:

Department of Administration
Purchasing Division
2019 Washington Street East
Post Office Box 50130
Charleston, WV 25305-0130

ADDENDUM #2

708EC009

OPEN END CONTRACT

10 FOOT OR 11 FOOT POWER REVERSIBLE SNOWPLOW (HYDRAULIC)

CHANGES TO SPECIFICATIONS:

FROM:

3.2 MANDATORY SPECIFICATIONS (1st Paragraph 1st Sentence Only-Rest Remains The Same)

All specifications preceded by “shall and/or must” or are stated as a “minimum and/or maximum” are mandatory.

TO:

3.2 MANDATORY SPECIFICATIONS (1st Paragraph 1st Sentence Only-Rest Remains The Same)

All specifications preceded by “shall, will, and/or must” or are stated as a “minimum and/or maximum” are mandatory.

FROM:

4.2 DELIVERY: (2nd Paragraph 2nd Sentence Only – Rest Remains The Same)
Delivery is preferred within 135 days after receipt of purchase agreement.

TO:

4.2 DELIVERY: (2nd Paragraph 2nd Sentence Only – Rest Remains The Same)
Delivery is preferred within 135 days to 150 maximum days after receipt of purchase agreement.

ADD:

6.3 TRAINING (Add to End of 1st Paragraph)
NOTE: Training does not apply to these snowplows

FROM:

7.0 SPECIFICATIONS OF THE QUOTED UNIT AS FOLLOWS: (4th Paragraph Only – Rest Remains the Same)
The snowplow to be a Valk RV1142 Reversible Snowplow or equal

TO:

7.0 SPECIFICATIONS OF THE QUOTED UNIT AS FOLLOWS: (4th Paragraph Only – Rest Remains the Same)
The snowplow to be a Valk RV1142 11 Foot or RV1042 10 Foot Reversible Snowplow or equal

FROM:

7.1.7 **Vertical Ribs: Minimum of six (6) vertical ribs, 1/2" by 3" formed steel with two (2) ribs at each hinge point.**

TO:

7.1.7 **Vertical Ribs: Minimum of six (6) vertical ribs, 1/2" by 3" formed steel with two (2) ribs at each hinge point OR will accept one (1) full height rib and one (1) short rib that doubles the thickness at the hinge point as long as we have six (6) full height vertical ribs**

FROM:

7.3.3 **Tripping mechanism shall be equipped with external cushion spring for absorbing shock when moldboard returns to normal plowing position.**

TO:

7.3.3 **Tripping mechanism shall be equipped with external cushion spring for absorbing shock when moldboard returns to normal plowing position OR will accept dual compression trip design spring assemblies**

FROM:

7.4.4.3 **Hydraulic power reverse mechanism shall include a dual cross-over relief cushion valve rated at a minimum of 40 G.P.M.**

TO:

7.4.4.3 **Hydraulic power reverse mechanism shall include a dual cross-over relief cushion valve rated at a minimum of 30 G.P.M. to be mounted on the push frame assembly and not on the hitch.**

FROM:

7.10 Paint: The entire unit to be painted in accordance with West Virginia Division of Highways requirements as follows:

TO:

7.10 Paint: The entire unit to be painted or powder coated in accordance with West Virginia of Highways requirements as follows:

FROM:

7.12 All loose hardware to be in a separate container for each plow and shipped with each plow.

TO:

7.12 All loose hardware to be in separate water tight containers, attached to and shipped with each plow.

ADDENDUM #2

708EC009

OPEN END CONTRACT

10 FOOT OR 11 FOOT POWER REVERSIBLE SNOWPLOW (HYDRAULIC)

CHANGES TO BIDDER'S EVALUATION REPORT:

X3.2 NO CHANGE REQUIRED

DELIVERY:

X4.2.2 NO CHANGE REQUIRED

DELETE:

X6.3 TRAINING (1st, 2nd, 3rd, 4th Paragraphs -- Paragraph 5 Remains)

NOTE: Training does not apply to snowplows

FROM:

X7.0 SPECIFICATIONS OF THE QUOTED UNIT: (Change to Paragraph 8 Only -- Rest Remains the Same)

Manufacturer: _____ Model: _____

TO:

X7.0 SPECIFICATIONS OF THE QUOTED UNIT: (Change to Paragraph 8 Only -- Rest Remains the Same)

10 Foot Manufacturer: Monroe Model: MP41R10 WVA

11 Foot Manufacturer: Monroe Model: MP41R11 WVA

FROM:

X7.1.7 **Number of vertical ribs** _____ **Formed steel** _____
How many ribs at each hinge point? _____

TO:

X7.1.7 Number of vertical ribs 6 Formed steel 1/2" plate

How many ribs at each hinge point? _____

OR

1 full height rib and 1 short rib that doubles the thickness at the hinge point as long as we have six (6) full height vertical ribs

FROM:

X7.3.3 Is tripping mechanism equipped with external cushion spring for absorbing shock? _____ YES _____ NO

TO:

X7.3.3 Is tripping mechanism equipped with external cushion spring for absorbing shock? _____ YES _____ NO

OR

Is it dual compression trip design spring assembly x YES _____ NO

FROM:

X7.4.4.3 Does hydraulic power reverse mechanism include a dual cross-over relief cushion valve? _____ YES _____ NO Rated at _____ GPM

TO:

X7.4.4.3 Does hydraulic power reverse mechanism include a dual cross-over relief cushion valve? x YES _____ NORated at 30 GPMMounted on the push frame assembly and not on hitch x YES _____ NO

X7.10. Paint: NO CHANGE REQUIRED

FROM:

X7.12 Will all loose hardware be in separate containers for each plow and be shipped with each plow? _____ YES _____ NO

TO:

X7.12 Will all loose hardware be in separate water tight containers attached to and shipped with each plow? x YES _____ NO

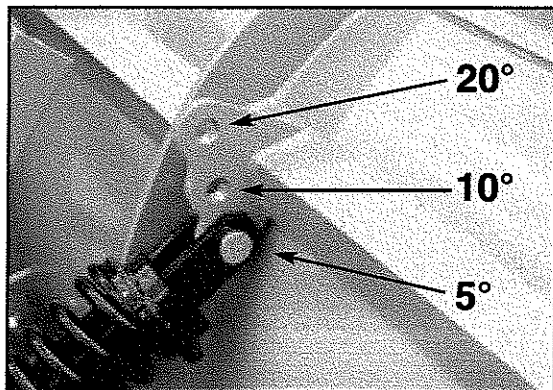

Simple Three Position Adjustment for Plow Cutting Edge Attack Angle

Options:

- * Rubber Snow Deflector
- * Wrap Around Curb Guards
- * Flexible Plastic or Cable Markers
- * Adjustable Parking Jack
- * Moldboard Shoes
- * 3/4" x 6" Carbide Cutting Edge
- * 4" Reversing Cylinders
- * Mechanical or Canister Trip
- * Polymer Moldboard
- * Skid Shoes, Steel Casters & Pneumatic Tires

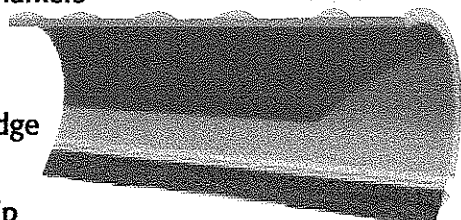

Shown Polymer Moldboard

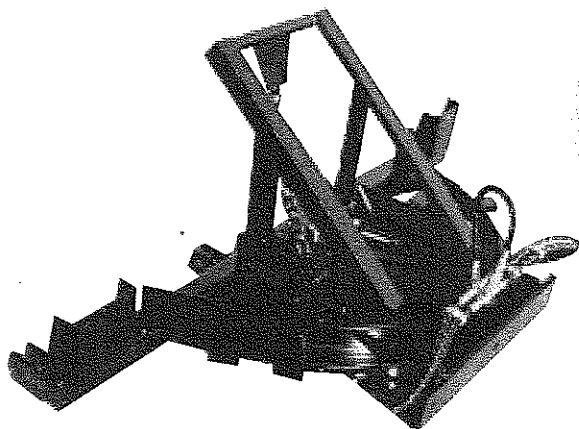

The Patented Level Lift allows plow to be parallel to the road surface at all times - raised, lowered, or angled.

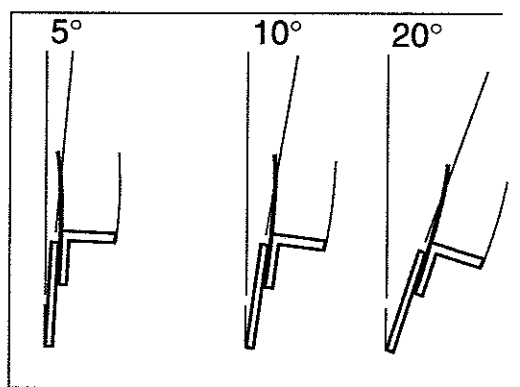

Force Required to Trip Moldboard

LIGHT TRIP

MEDIUM TRIP

HARD TRIP

THE MONROE SNOWPLOW SPECIFICATIONS

PLOW MODEL NO.	OVERALL LENGTH	HEIGHT W/8X8" CUTTING EDGE	NO. OF 1/2" VERTICAL RIBS	SEMI CIRCLE	MOLDBOARD BOTTOM ANGLE	MOLDBOARD TOP ANGLE	CUTTING EDGE SIZE	APPROX. WEIGHT (LBS)	MOLDBOARD THICKNESS	CUTTING WIDTH AT 35 DEGREES
MP36R10-CT	10'	36"	6	3 1/2" X 3 1/2" X 1/2"	4" X 4" X 3/4"	2" X 3" X 3/4"	3/4" X 8"	1475	10 GA	8'2"
MP36R10-ISCT	10'	36"	6	3 1/2" X 3 1/2" X 1/2"	4" X 4" X 3/4"	2" X 3" X 3/4"	3/4" X 8"	1500	10 GA	8'2"
MP36R11-CT	11'	36"	6	3 1/2" X 3 1/2" X 1/2"	4" X 4" X 3/4"	2" X 3" X 3/4"	3/4" X 8"	1500	10 GA	9'0"
MP36R11-ISCT	11'	36"	6	3 1/2" X 3 1/2" X 1/2"	4" X 4" X 3/4"	2" X 3" X 3/4"	3/4" X 8"	1525	10 GA	9'0"
MP41R10-CT	10'	41"	6	3 1/2" X 3 1/2" X 1/2"	4" X 4" X 3/4"	2" X 3" X 3/4"	3/4" X 8"	1575	10 GA	8'2"
MP41R10-ISCT	10'	41"	6	3 1/2" X 3 1/2" X 1/2"	4" X 4" X 3/4"	2" X 3" X 3/4"	3/4" X 8"	1575	10 GA	8'2"
MP41R11-CT	11'	41"	6	3 1/2" X 3 1/2" X 1/2"	4" X 4" X 3/4"	2" X 3" X 3/4"	3/4" X 8"	1625	10 GA	9'0"
MP41R11-ISCT	11'	41"	6	3 1/2" X 3 1/2" X 1/2"	4" X 4" X 3/4"	2" X 3" X 3/4"	3/4" X 8"	1650	10 GA	9'0"
MP41R12-CT	12'	41"	6	3 1/2" X 3 1/2" X 1/2"	4" X 4" X 3/4"	2" X 3" X 3/4"	3/4" X 8"	1695	10 GA	9'10"
MP41R12-ISCT	12'	41"	6	3 1/2" X 3 1/2" X 1/2"	4" X 4" X 3/4"	2" X 3" X 3/4"	3/4" X 8"	1725	10 GA	9'10"
MP48R11-CT	11'	48"	6	3 1/2" X 3 1/2" X 1/2"	4" X 4" X 3/4"	2" X 3" X 3/4"	3/4" X 8"	1755	10 GA	9'0"
MP48R11-ISCT	11'	48"	6	3 1/2" X 3 1/2" X 1/2"	4" X 4" X 3/4"	2" X 3" X 3/4"	3/4" X 8"	1800	10 GA	9'0"
MP48R12-CT	12'	48"	6	3 1/2" X 3 1/2" X 1/2"	4" X 4" X 3/4"	2" X 3" X 3/4"	3/4" X 8"	1845	10 GA	9'10"
MP48R12-ISCT	12'	48"	6	3 1/2" X 3 1/2" X 1/2"	4" X 4" X 3/4"	2" X 3" X 3/4"	3/4" X 8"	2000	10 GA	9'10"

Manufactured by:

Monroe Snow & Ice Control

1051 W. 7th Street • Monroe, WI 53566

800-880-0109 • 608-329-8105

608-328-8390 Fax

Web Site: www.monroetruck.com

E-mail: snowandicecontrol@monroetruck.com

MIDDLETOWN TRACTOR SALES
2345 WHITEHALL BLVD.
FAIRMONT, WV 26554



MONROE REVERSIBLE SNOWPLOW FULL TRIP MOLDBOARD

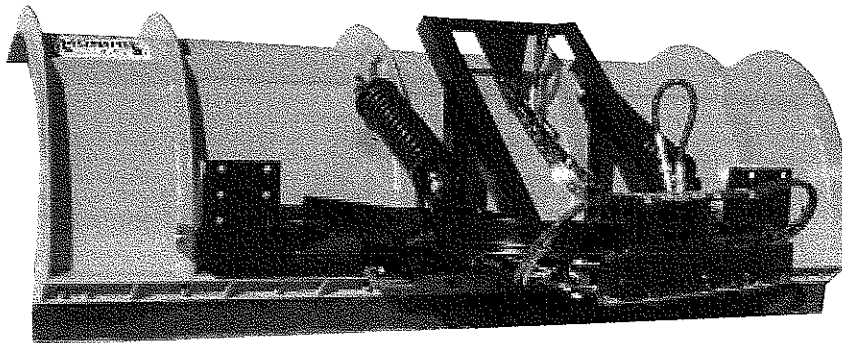

Standard Specifications:

- * 10 Gauge Roll Formed Moldboard
- * Six 1pc 1/2" Flame Cut Ribs
- * Dual Compression Trip Spring Assemblies
- * Two 3" x 10" Double Acting Power Reverse Cylinders with Cushion Valve
- * Built-In Monroe Level Lift Assembly
- * Stress Proof Machined Pins
- * All Hardware Zinc Plated
- * Moldboard and Pushframe 100% Continuously Welded
- * Moldboard Painted Powder Coat Orange
- * Pushframe Painted Powder Coat Black
- * 14" Push Height
- * Available in 10', 11' & 12'

STANDARD

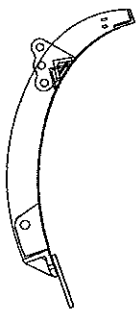

INTEGRAL

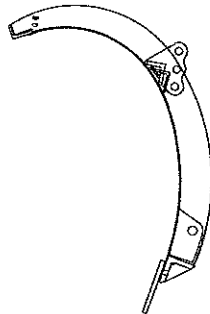

Standard Moldboard vs 12" Extension on
Integral Shield Moldboard

VISIT US ONLINE AT
www.monroetruck.com



CAUTION: Plow weight, mounting distance from axle, hitch type and weight, and other additional equipment mounted on the front of a truck will require heavier truck GAWR (Gross Axle Weight Ratings). Contact chassis manufacturer for exact GAWR requirements for your specific equipment.



1051 W. 7th Street • Monroe, WI 53566
800-880-0109 • 608-329-8105 • FAX 608-328-8390
E-mail: snowandicecontrol@monroetruck.com • Website: www.monroetruck.com

**WARRANTY POLICY (West Virginia)
RFQ 708EC009**

Uninstalled Parts and Equipment provided by Monroe Truck Equipment

Monroe Truck Equipment will provide the following limited warranty for a period of two years to the original purchaser of all uninstalled goods provided by Monroe Truck Equipment.

LIMITED WARRANTY: All goods provided by Monroe Truck Equipment (MTE) will be free from defects in material and workmanship for a period of two years from the date of purchase by the original purchaser. This limited warranty shall be the sole and exclusive remedy for any such product found to be defective. This limited warranty supercedes all previous warranties and is exclusive and in lieu of all other warranties, whether expressed or implied.

This limited warranty applies only to parts or accessories manufactured by MTE and/or provided by same. Except with respect to title, this limited warranty does not pertain to parts or accessories not manufactured and/or provided by MTE, regardless of whether such parts or accessories were selected and/or recommended by MTE. MTE will, as a service to the buyer, pass on any warranties received from the original manufacturer of MTE provided parts and/or accessories.

MTE will not under any circumstances be liable for any incidental or consequential damages whether in tort, contract, or otherwise, for any bodily injury, death, property damage, loss of use, or loss of income resulting from or in any way arising out of any goods provided by MTE, or their sale, use, or manufacture.

Any warranty claim deemed to be arising from the result of misuse, abuse, neglect, accident, improper installation, lack of maintenance, act of war (whether declared or otherwise), or act of God will be denied. Any repair or modification by the buyer or any third party, without the prior written consent of MTE, will void any possible warranty compensation. Any damage deemed to be the result of abnormal operation will not be compensated by this warranty.

Normal or special maintenance items such as fuels, fluids, tires, belts, hoses, filters, air cleaners, light bulbs, and any other items subject to normal wear and tear that are supplied in connection with goods provided by MTE are not allowed under this warranty.

Electrical and hydraulic components are not to be disassembled without the express written consent of MTE. Any disassembly of MTE provided components without prior authorization will void the applicable warranty.

Monroe Truck Equipment shall be the sole and final determining authority as it applies to the administration of this warranty policy. Purchaser acknowledges receipt of Monroe Truck Equipment Warranty Policy and agrees to be bound by same.

Any and all warranty claims must be forwarded to MTE within 10 days of defect discovery. A copy of the original Monroe Truck Equipment invoice as well as the manufacturer's model number, serial number, and date of installation must accompany all correspondence regarding said claims. MTE will, at their option, choose whether to repair or replace the defective part unless otherwise specified by the original manufacturer of said part.

Procedures for Warranty Claims Notification

For submission of any warranty claim, please contact Monroe Truck Equipment – Warranty Dept. at 800-356-8134. The following documentation will be needed when you call for initial warranty authorization.

- A copy of the original MTE invoice.
- Make, Model, and VIN or Serial number of the equipment involved.
- Part number and serial number of the part in question.
- A complete description of the problem.

The following must accompany and claim submitted to Monroe Truck Equipment:

- Documented photographs of any physical damage.
- Inspection notes by MTE personnel or MTE authorized 3rd party.
- Authorization number issued by Monroe Truck Equipment – Warranty Department.

Defective parts must be returned to Monroe Truck Equipment (freight pre-paid) within 30 days of issuance of Authorization Number.

Monroe Truck Equipment reserves the right to void any warranty for failure to comply with Monroe Truck Equipment Warranty Policy.

This policy is effective November 5, 2007



Reversible & One-way Snowplows • Airport Snowplow • Heavy Duty Patrol Wing
 Heavy Duty Benching Wing • Monroe Underbody Scraper • Heavy Duty V-box Spreader
 Under Tailgate Spreader • Pickup V-box Spreader • Replacement Tailgate Spreader
 Anti-Icing/De-icing & Vegetation Sprayer • Construction Attachments

