



State of West Virginia
 Department of Administration
 Purchasing Division
 2019 Washington Street East
 Post Office Box 50130
 Charleston, WV 25305-0130

Request for Quotation

RFO NUMBER
708EC008

PAGE
1

ADDRESS CORRESPONDENCE TO ATTENTION OF
MICHAEL AUSTIN
304-558-2402

RFQ COPY
 TYPE NAME/ADDRESS HERE

Logan Corporation
Rt. 2 Box 924
Clarksburg, WV 26301

DIVISION OF HIGHWAYS
EQUIPMENT DIVISION
ROUTE 33
BRUSHY FORK ROAD
BUCKHANNON, WV
26201 **304-472-1750**

DATE PRINTED	TERMS OF SALE	SHIP VIA	FOB	FREIGHT TERMS
11/26/2007	Net 30	Motor Truck	Buckhannon, WV	Prepaid

BID OPENING DATE: **12/27/2007** BID OPENING TIME: **01:30PM**

LINE	QUANTITY	UOP	CAT NO	ITEM NUMBER	UNIT PRICE	AMOUNT
1001	1	EA		760-75	\$ 29,654.00 Terex Tv-1200	\$ 29,654.00
<p>DOUBLE DRUM VIBRATORY ROLLER/COMPACTOR</p> <p>OPEN END CONTRACT</p> <p>TO PROVIDE DOUBLE DRUM VIBRATORY ROLLER/COMPACTOR AS DESCRIBED IN ATTACHED PROCUREMENT SPECIFICATIONS.</p> <p>THERE WILL BE A MANDATORY PRE-BID CONFERENCE AT THE STATE CAPITOL COMPLEX, 2019 WASHINGTON STREET EAST, CHARLESTON, WV 25305 AT 10:00 AM ON 12/13/2007. FAILURE TO ATTEND THE PRE-BID CONFERENCE WILL RESULT IN BID DISQUALIFICATION.</p> <p>QUESTIONS: WRITTEN QUESTIONS WILL BE ACCEPTED THROUGH CLOSE OF BUSINESS (5:00 PM EST) ON WEDNESDAY 12/06/07. SEND YOUR QUESTIONS TO: PURCHASING DIVISION ATTENTION MICHAEL AUSTIN 2019 WASHINGTON ST. EAST. CHARLESTON, WV. 25305</p> <p>QUESTIONS MAY BE SENT VIA FAX, EMAIL, OR REGULAR MAIL. E-MAIL: MAUSTIN@WVADMIN.GOV FAX: 304-558-4115</p> <p>IT IS THE VENDORS RESPONSIBILITY TO VERIFY THAT THEIR QUESTIONS HAVE BEEN RECEIVED BY CALLING 304-558-2402.</p> <p>EXHIBIT 2</p> <p>LIFE OF CONTRACT: THIS CONTRACT BECOMES EFFECTIVE ON AND EXTENDS FOR A PERIOD OF ONE (1) YEAR OR UNTIL SUCH "REASONABLE TIME" THEREAFTER AS IS</p>						

RECEIVED
 2007 DEC 27 10 00 AM
 PURCHASING DIVISION

SEE REVERSE SIDE FOR TERMS AND CONDITIONS

NATURE: *Joseph M. Donalds* TELEPHONE: *304-623-5670* DATE: *12/23/07*
 Territory Mgr. FEIN: *55-0219530* ADDRESS CHANGES TO BE NOTED ABOVE

WHEN RESPONDING TO RFQ, INSERT NAME AND ADDRESS IN SPACE ABOVE LABELED 'VENDOR'

**GENERAL TERMS & CONDITIONS
REQUEST FOR QUOTATION (RFQ) AND REQUEST FOR PROPOSAL (RFP)**

1. Awards will be made in the best interest of the State of West Virginia.
2. The State may accept or reject in part, or in whole, any bid.
3. All quotations are governed by the *West Virginia Code* and the *Legislative Rules* of the Purchasing Division.
4. Prior to any award, the apparent successful vendor must be properly registered with the Purchasing Division and have paid the required \$125.00 registration fee.
5. All services performed or goods delivered under State Purchase Orders/Contracts are to be continued for the term of the Purchase Order/Contract, contingent upon funds being appropriated by the Legislature or otherwise being made available. In the event funds are not appropriated or otherwise available for these services or goods, this Purchase Order/Contract becomes void and of no effect after June 30.
6. Payment may only be made after the delivery and acceptance of goods or services.
7. Interest may be paid for late payment in accordance with the *West Virginia Code*.
8. Vendor preference will be granted upon written request in accordance with the *West Virginia Code*.
9. The State of West Virginia is exempt from federal and state taxes and will not pay or reimburse such taxes.
10. The Director of Purchasing may cancel any Purchase Order/Contract upon 30 days written notice to the seller.
11. The laws of the State of West Virginia and the *Legislative Rules* of the Purchasing Division shall govern all rights and duties under the Contract, including without limitation the validity of this Purchase Order/Contract.
12. Any reference to automatic renewal is hereby deleted. The Contract may be renewed only upon mutual written agreement of the parties.
13. **BANKRUPTCY:** In the event the vendor/contractor files for bankruptcy protection, this Contract may be deemed null and void, and terminated without further order.
14. **HIPAA Business Associate Addendum -** The West Virginia State Government HIPAA Business Associate Addendum (BAA), approved by the Attorney General, and available online at the Purchasing Division's web site (<http://www.state.wv.us/admin/purchase/vrc/hipaa.htm>) is hereby made part of the agreement. Provided that, the Agency meets the definition of a Covered Entity (45 CFR §160.103) and will be disclosing Protected Health Information (45 CFR §160.103) to the vendor.

INSTRUCTIONS TO BIDDERS

1. Use the quotation forms provided by the Purchasing Division.
2. **SPECIFICATIONS:** Items offered must be in compliance with the specifications. Any deviation from the specifications must be clearly indicated by the bidder. Alternates offered by the bidder as **EQUAL** to the specifications must be clearly defined. A bidder offering an alternate should attach complete specifications and literature to the bid. The Purchasing Division may waive minor deviations to specifications.
3. Complete all sections of the quotation form.
4. Unit prices shall prevail in cases of discrepancy.
5. All quotations are considered F.O.B. destination unless alternate shipping terms are clearly identified in the quotation.
6. **BID SUBMISSION:** All quotations must be delivered by the bidder to the office listed below prior to the date and time of the bid opening. Failure of the bidder to deliver the quotations on time will result in bid disqualifications.

SIGNED BID TO:

Department of Administration
Purchasing Division
2019 Washington Street East
Post Office Box 50130
Charleston, WV 25305-0130



State of West Virginia
 Department of Administration
 Purchasing Division
 2019 Washington Street East
 Post Office Box 50130
 Charleston, WV 25305-0130

Request for Quotation

RFO NUMBER:
708EC008

PAGE:
2

ADDRESS CORRESPONDENCE TO ATTENTION OF:
**MICHAEL AUSTIN
 304-558-2402**

RFQ COPY
 TYPE NAME/ADDRESS HERE

*Logan Corporation
 Rt-2 Box 924
 Clarksburg, WV 26301*

**DIVISION OF HIGHWAYS
 EQUIPMENT DIVISION
 ROUTE 33
 BRUSHY FORK ROAD
 BUCKHANNON, WV
 26201 304-472-1750**

DATE PRINTED	TERMS OF SALE	SHIP VIA	FOB	FREIGHT TERMS
11/26/2007				
BID OPENING DATE: 12/27/2007		BID OPENING TIME 01:30PM		

LINE	QUANTITY	UQP	CAT NO	ITEM NUMBER	UNIT PRICE	AMOUNT
<p>NECESSARY TO OBTAIN A NEW CONTRACT OR RENEW THE ORIGINAL CONTRACT. THE "REASONABLE TIME" PERIOD SHALL NOT EXCEED TWELVE (12) MONTHS. DURING THIS "REASONABLE TIME" THE VENDOR MAY TERMINATE THIS CONTRACT FOR ANY REASON UPON GIVING THE DIRECTOR OF PURCHASING THIRTY (30) DAYS WRITTEN NOTICE.</p> <p>UNLESS SPECIFIC PROVISIONS ARE STIPULATED IN THIS CONTRACT DOCUMENT, THE TERMS, CONDITIONS, AND PRICING SET HEREIN ARE FIRM FOR THE LIFE OF THE CONTRACT.</p> <p>RENEWAL: THIS CONTRACT MAY BE RENEWED UPON THE MUTUAL WRITTEN CONSENT OF THE SPENDING UNIT AND VENDOR, SUBMITTED TO THE DIRECTOR OF PURCHASING THIRTY (30) DAYS PRIOR TO THE EXPIRATION DATE. SUCH RENEWAL SHALL BE IN ACCORDANCE WITH THE TERMS AND CONDITIONS OF THE ORIGINAL CONTRACT AND SHALL BE LIMITED TO TWO (2) ONE (1) YEAR PERIODS.</p> <p>CANCELLATION: THE DIRECTOR OF PURCHASING RESERVES THE RIGHT TO CANCEL THIS CONTRACT IMMEDIATELY UPON WRITTEN NOTICE TO THE VENDOR IF THE COMMODITIES AND/OR SERVICES SUPPLIED ARE OF AN INFERIOR QUALITY OR DO NOT CONFORM WITH THE SPECIFICATIONS OF THE BID AND CONTRACT HEREIN</p> <p>OPEN MARKET CLAUSE: THE DIRECTOR OF PURCHASING MAY AUTHORIZE A SPENDING UNIT TO PURCHASE ON THE OPEN MARKET, WITHOUT THE FILING OF A REQUISITION OR COST ESTIMATE, ITEMS SPECIFIED ON THIS CONTRACT FOR IMMEDIATE DELIVERY IN EMERGENCIES DUE TO UNFORESEEN CAUSES (INCLUDING BUT NOT LIMITED TO DELAYS IN TRANSPORTATION OR AN UNANTICIPATED INCREASE IN THE VOLUME OF WORK).</p> <p>QUANTITIES: QUANTITIES LISTED IN THE REQUISITION ARE APPROXIMATIONS ONLY, BASED ON ESTIMATES SUPPLIES BY THE STATE SPENDING UNIT. IT IS UNDERSTOOD AND AGREED THAT</p>						

SEE REVERSE SIDE FOR TERMS AND CONDITIONS

SIGNATURE <i>Joseph M. Haralsh</i>	TELEPHONE <i>304-623-5670</i>	DATE <i>12/23/07</i>
TITLE <i>Territory Mgr.</i>	FEIN <i>55-0219530</i>	ADDRESS CHANGES TO BE NOTED ABOVE

WHEN RESPONDING TO RFQ, INSERT NAME AND ADDRESS IN SPACE ABOVE LABELED 'VENDOR'



State of West Virginia
 Department of Administration
 Purchasing Division
 2019 Washington Street East
 Post Office Box 50130
 Charleston, WV 25305-0130

Request for Quotation

RFQ NUMBER
708EC008

PAGE
3

ADDRESS CORRESPONDENCE TO ATTENTION OF
**MICHAEL AUSTIN
 304-558-2402**

RFQ COPY
 TYPE NAME/ADDRESS HERE

*Logan Corporation
 Rt. 2 Box 924
 Clarksburg, WV 26301*

**DIVISION OF HIGHWAYS
 EQUIPMENT DIVISION
 ROUTE 33
 BRUSHY FORK ROAD
 BUCKHANNON, WV
 26201 304-472-1750**

DATE PRINTED	TERMS OF SALE	SHIP VIA	FOB	FREIGHT TERMS
11/26/2007				

BID OPENING DATE: **12/27/2007** BID OPENING TIME **01:30PM**

LINE	QUANTITY	UOP	CAT. NO.	ITEM NUMBER	UNIT PRICE	AMOUNT
<p>THE CONTRACT SHALL COVER THE QUANTITIES ACTUALLY ORDERED FOR DELIVERY DURING THE TERM OF CONTRACT, WHETHER MORE OR LESS THAN THE QUANTITIES SHOWN.</p> <p>ORDERING PROCEDURE: SPENDING UNIT(S) SHALL ISSUE A WRITTEN EQUIPMENT CONTRACT ORDER (FORM NUMBER WV-35) FOR COMMODITIES COVERED BY THIS CONTRACT. THE ORIGINAL WV-35 MUST BE SENT TO THE PURCHASING DIVISION OF THE DEPARTMENT OF ADMINISTRATION. AFTER APPROVAL AND ENCUMBRANCE, ONE COPY OF THE PURCHASE ORDER WILL BE RETURNED TO THE SPENDING UNIT AND ONE COPY FORWARDED TO THE VENDOR AS AUTHORIZATION FOR SHIPMENT. NO ORDER IS VALID UNLESS APPROVED AND ENCUMBERED BY THE PURCHASING DIVISION.</p> <p>BANKRUPTCY: IN THE EVENT THE VENDOR/CONTRACTOR FILES FOR BANKRUPTCY PROTECTION, THIS CONTRACT IS AUTOMATICALLY NULL AND VOID, AND IS TERMINATED WITHOUT FURTHER ORDER.</p> <p>EXHIBIT 6</p> <p>PRICE ADJUSTMENT PROVISION: THE STATE OF WEST VIRGINIA WILL CONSIDER BIDS THAT CONTAIN PROVISIONS FOR PRICE ADJUSTMENTS PRIOR TO THE ORIGINAL EXPIRATION OF THE CONTRACT, PROVIDED THAT SUCH PRICE ADJUSTMENT COVERS BOTH UPWARD AND DOWNWARD MOVEMENT OF THE COMMODITY PRICE, AND THAT ADJUSTMENT IS BASED ON THE "PASS THROUGH" INCREASE OR DECREASE OF RAW MATERIALS AND/OR LABOR, WHICH MAKE UP ALL OR A SUBSTANTIAL PART OF A PRODUCT. ADJUSTMENTS ARE TO BE BASED UPON AN ACTUAL DOLLAR FIGURE, NOT A PERCENTAGE. ALL PRICE ADJUSTMENT REQUESTS MUST BE SUBSTANTIATED IN A MANNER ACCEPTABLE TO THE DIRECTOR PURCHASING, E.G. GOVERNMENTAL BENCH MARKS, GENERAL MARKET INCREASE,</p>						

SEE REVERSE SIDE FOR TERMS AND CONDITIONS

SIGNATURE <i>Joseph M. Anello</i>	TELEPHONE <i>304-623-5670</i>	DATE <i>12/23/07</i>
TITLE <i>Territory Mgr.</i>	FEIN <i>55-0219530</i>	ADDRESS CHANGES TO BE NOTED ABOVE

WHEN RESPONDING TO RFQ, INSERT NAME AND ADDRESS IN SPACE ABOVE LABELED 'VENDOR'



State of West Virginia
 Department of Administration
 Purchasing Division
 2019 Washington Street East
 Post Office Box 50130
 Charleston, WV 25305-0130

Request for Quotation

RFQ NUMBER
708EC008

PAGE
4

ADDRESS CORRESPONDENCE TO ATTENTION OF
**MICHAEL AUSTIN
 304-558-2402**

RFQ COPY
 TYPE NAME/ADDRESS HERE

*Logan Corporation
 Rt. 2 Box 924
 Clarksburg, WV 26301*

DIVISION OF HIGHWAYS
 EQUIPMENT DIVISION
 ROUTE 33
 BRUSHY FORK ROAD
 BUCKHANNON, WV
 26201 304-472-1750

DATE PRINTED	TERMS OF SALE	SHIP VIA	F.O.B.	FREIGHT TERMS
11/26/2007				

BID OPENING DATE: **12/27/2007** BID OPENING TIME **01:30PM**

LINE	QUANTITY	UOP	CAT. NO.	ITEM NUMBER	UNIT PRICE	AMOUNT
<p>PUBLISHED PRICE LISTS. SUCH REQUESTS FOR AND INCREASE SHOULD BE RECEIVED IN WRITING BY THE DIRECTOR OF PURCHASING AT LEAST 30 DAYS IN ADVANCE OF THE EFFECTIVE DATE OF THE INCREASE. ANY TIME THE VENDOR REQUESTS A PRICE ADJUSTMENT, THE PURCHASING DIVISION MAY EITHER ACCEPT THE PRICE ADJUSTMENT AND AMEND THE CONTRACT ACCORDINGLY OR REJECT THE ADJUSTMENT IN ITS ENTIRETY AND CANCEL THE CONTRACT.</p> <p>PURCHASING CARD ACCEPTANCE: THE STATE OF WEST VIRGINIA CURRENTLY UTILIZES A VISA PURCHASING CARD PROGRAM WHICH IS ISSUED THROUGH A BANK. THE SUCCESSFUL VENDOR MUST ACCEPT THE STATE OF WEST VIRGINIA VISA PURCHASING CARD FOR PAYMENT OF ALL ORDERS PLACED BY ANY STATE AGENCY AS A CONDITION OF AWARD.</p> <p>EXHIBIT 10</p> <p>REQUISITION NO.:</p> <p>ADDENDUM ACKNOWLEDGEMENT</p> <p>I HEREBY ACKNOWLEDGE RECEIPT OF THE FOLLOWING CHECKED ADDENDUM(S) AND HAVE MADE THE NECESSARY REVISIONS TO MY PROPOSAL, PLANS AND/OR SPECIFICATION, ETC.</p> <p>ADDENDUM NO.'S:</p> <p>NO. 1 ✓</p> <p>NO. 2</p> <p>NO. 3</p>						

SEE REVERSE SIDE FOR TERMS AND CONDITIONS

SIGNATURE <i>Joseph M. Shields</i>	TELEPHONE <i>304-623-5670</i>	DATE <i>12/23/07</i>
TITLE <i>Territory Mgr.</i>	FAX <i>55-0219530</i>	ADDRESS CHANGES TO BE NOTED ABOVE

WHEN RESPONDING TO RFQ, INSERT NAME AND ADDRESS IN SPACE ABOVE LABELED 'VENDOR'



State of West Virginia
 Department of Administration
 Purchasing Division
 2019 Washington Street East
 Post Office Box 50130
 Charleston, WV 25305-0130

Request for Quotation

RFQ NUMBER
708EC008

PAGE
5

ADDRESS CORRESPONDENCE TO ATTENTION OF
MICHAEL AUSTIN
304-558-2402

RFQ COPY
 TYPE NAME/ADDRESS HERE

PROPERTY

Logan Corporation
RF-2, Box 924
Clarksburg, WV 26301

SHIP TO

DIVISION OF HIGHWAYS
EQUIPMENT DIVISION
ROUTE 33
BRUSHY FORK ROAD
BUCKHANNON, WV
26201 **304-472-1750**

DATE PRINTED	TERMS OF SALE	SHIP VIA	F.O.B.	FREIGHT TERMS
11/26/2007				

BID OPENING DATE: **12/27/2007** BID OPENING TIME **01:30PM**

LINE	QUANTITY	LIQ	CAT NO	ITEM NUMBER	UNIT PRICE	AMOUNT
	NO. 4					
	NO. 5					
<p>I UNDERSTAND THAT FAILURE TO CONFIRM THE RECEIPT OF THE ADDENDUM(S) MAY BE CAUSE FOR REJECTION OF BIDS.</p> <p>VENDOR MUST CLEARLY UNDERSTAND THAT ANY VERBAL REPRESENTATION MADE OR ASSUMED TO BE MADE DURING ANY ORAL DISCUSSION HELD BETWEEN VENDOR'S REPRESENTATIVES AND ANY STATE PERSONNEL IS NOT BINDING. ONLY THE INFORMATION ISSUED IN WRITING AND ADDED TO THE SPECIFICATIONS BY AN OFFICIAL ADDENDUM IS BINDING.</p> <p style="text-align: center;"> <i>Joseph M. Donald</i> SIGNATURE <i>Logan Corporation</i> COMPANY <i>12/23/07</i> DATE </p> <p style="text-align: center;">VENDOR PREFERENCE CERTIFICATE</p> <p>CERTIFICATION AND APPLICATION* IS HEREBY MADE FOR PREFERENCE IN ACCORDANCE WITH WEST VIRGINIA CODE, 5A-3-37 (DOES NOT APPLY TO CONSTRUCTION CONTRACTS).</p> <p>A. APPLICATION IS MADE FOR 2.5% PREFERENCE FOR THE REASON CHECKED:</p> <p>() BIDDER IS AN INDIVIDUAL RESIDENT VENDOR AND HAS RESIDED CONTINUOUSLY IN WEST VIRGINIA FOR FOUR</p>						

SEE REVERSE SIDE FOR TERMS AND CONDITIONS		
SIGNATURE <i>Joseph M. Donald</i>	TELEPHONE <i>304-623-5070</i>	DATE <i>12/23/07</i>
TITLE <i>Territory Mgr.</i>	FEIN <i>55-0219530</i>	ADDRESS CHANGES TO BE NOTED ABOVE

WHEN RESPONDING TO RFQ, INSERT NAME AND ADDRESS IN SPACE ABOVE LABELED 'VENDOR'



State of West Virginia
 Department of Administration
 Purchasing Division
 2019 Washington Street East
 Post Office Box 50130
 Charleston, WV 25305-0130

Request for Quotation

RFQ NUMBER
708EC008

PAGE
6

ADDRESS CORRESPONDENCE TO ATTENTION OF
**MICHAEL AUSTIN
 304-558-2402**

RFQ COPY
 TYPE NAME/ADDRESS HERE

*Logan Corporation
 Rt. 2 Box 924
 Clarksburg, WV 26301*

DIVISION OF HIGHWAYS
 EQUIPMENT DIVISION
 ROUTE 33
 BRUSHY FORK ROAD
 BUCKHANNON, WV
 26201 304-472-1750

DATE PRINTED	TERMS OF SALE	SHIP VIA	F.O.B.	FREIGHT TERMS
11/26/2007				

BID OPENING DATE: **12/27/2007** BID OPENING TIME **01:30PM**

LINE	QUANTITY	UOP	CAT NO	ITEM NUMBER	UNIT PRICE	AMOUNT
<p>(4) YEARS IMMEDIATELY PRECEDING THE DATE OF THIS CERTIFICATION; OR</p> <p><input checked="" type="checkbox"/> BIDDER IS A PARTNERSHIP, ASSOCIATION OR CORPORATION RESIDENT VENDOR AND HAS MAINTAINED ITS HEAD-QUARTERS OR PRINCIPAL PLACE OF BUSINESS CONTINUOUSLY IN WEST VIRGINIA FOR FOUR (4) YEARS IMMEDIATELY PRECEDING THE DATE OF THIS CERTIFICATION; OR 80% OF THE OWNERSHIP INTEREST OF BIDDER IS HELD BY ANOTHER INDIVIDUAL, PARTNERSHIP, ASSOCIATION OR CORPORATION RESIDENT VENDOR WHO HAS MAINTAINED ITS HEADQUARTERS OR PRINCIPAL PLACE OF BUSINESS CONTINUOUSLY IN WEST VIRGINIA FOR FOUR (4) YEARS IMMEDIATELY PRECEDING THE DATE OF THIS CERTIFICATION; OR</p> <p>() BIDDER IS A CORPORATION NONRESIDENT VENDOR WHICH HAS AN AFFILIATE OR SUBSIDIARY WHICH EMPLOYS A MINIMUM OF ONE HUNDRED STATE RESIDENTS AND WHICH HAS MAINTAINED ITS HEADQUARTERS OR PRINCIPAL PLACE OF BUSINESS WITHIN WEST VIRGINIA CONTINUOUSLY FOR THE FOUR (4) YEARS IMMEDIATELY PRECEDING THE DATE OF THIS CERTIFICATION.</p> <p>B. APPLICATION IS MADE FOR 2.5% PREFERENCE FOR THE REASON CHECKED:</p> <p><input checked="" type="checkbox"/> BIDDER IS A RESIDENT VENDOR WHO CERTIFIES THAT, DURING THE LIFE OF THE CONTRACT, ON AVERAGE AT LEAST 75% OF THE EMPLOYEES WORKING ON THE PROJECT BEING BID ARE RESIDENTS OF WEST VIRGINIA WHO HAVE RESIDED IN THE STATE CONTINUOUSLY FOR THE TWO YEARS IMMEDIATELY PRECEDING SUBMISSION OF THIS BID;</p> <p>OR</p> <p>() BIDDER IS A NONRESIDENT VENDOR EMPLOYING A MINIMUM OF ONE HUNDRED STATE RESIDENTS OR IS A NONRESIDENT VENDOR WITH AN AFFILIATE OR SUBSIDIARY</p>						

SEE REVERSE SIDE FOR TERMS AND CONDITIONS

SIGNATURE <i>Joseph M. D'Amico</i>	TELEPHONE <i>304-623-5070</i>	DATE <i>12/23/07</i>
TITLE <i>Territory Mgr.</i>	FEIN <i>55-0219530</i>	ADDRESS CHANGES TO BE NOTED ABOVE

WHEN RESPONDING TO RFQ, INSERT NAME AND ADDRESS IN SPACE ABOVE LABELED 'VENDOR'



State of West Virginia
 Department of Administration
 Purchasing Division
 2019 Washington Street East
 Post Office Box 50130
 Charleston, WV 25305-0130

Request for Quotation

RFQ NUMBER
708EC008

PAGE
7

ADDRESS CORRESPONDENCE TO ATTENTION OF
**MICHAEL AUSTIN
 304-558-2402**

RFQ COPY
 TYPE NAME/ADDRESS HERE

*Logan Corporation
 Rt. 2 Box 924
 Clarksburg, WV 26301*

DIVISION OF HIGHWAYS
 EQUIPMENT DIVISION
 ROUTE 33
 BRUSHY FORK ROAD
 BUCKHANNON, WV
 26201 304-472-1750

DATE PRINTED	TERMS OF SALE	SHIP VIA	F.O.B.	FREIGHT TERMS
11/26/2007				

BID OPENING DATE: **12/27/2007** BID OPENING TIME **01:30PM**

LINE	QUANTITY	UOP	CAT NO	ITEM NUMBER	UNIT PRICE	AMOUNT
<p>WHICH MAINTAINS ITS HEADQUARTERS OR PRINCIPAL PLACE OF BUSINESS WITHIN WEST VIRGINIA EMPLOYING A MINIMUM OF ONE HUNDRED STATE RESIDENTS WHO CERTIFIES THAT, DURING THE LIFE OF THE CONTRACT, ON AVERAGE AT LEAST 75% OF THE EMPLOYEES OR BIDDERS' AFFILIATE'S OR SUBSIDIARY'S EMPLOYEES ARE RESIDENTS OF WEST VIRGINIA WHO HAVE RESIDED IN THE STATE CONTINUOUSLY FOR THE TWO YEARS IMMEDIATELY PRECEDING SUBMISSION OF THIS BID.</p> <p>BIDDER UNDERSTANDS IF THE SECRETARY OF TAX & REVENUE DETERMINES THAT A BIDDER RECEIVING PREFERENCE HAS FAILED TO CONTINUE TO MEET THE REQUIREMENTS FOR SUCH PREFERENCE, THE SECRETARY MAY ORDER THE DIRECTOR OF PURCHASING TO: (A) RESCIND THE CONTRACT OR PURCHASE ORDER ISSUED; OR (B) ASSESS A PENALTY AGAINST SUCH BIDDER IN AN AMOUNT NOT TO EXCEED 5% OF THE BID AMOUNT AND THAT SUCH PENALTY WILL BE PAID TO THE CONTRACTING AGENCY OR DEDUCTED FROM ANY UNPAID BALANCE ON THE CONTRACT OR PURCHASE ORDER.</p> <p>BY SUBMISSION OF THIS CERTIFICATE, BIDDER AGREES TO DISCLOSE ANY REASONABLY REQUESTED INFORMATION TO THE PURCHASING DIVISION AND AUTHORIZES THE DEPARTMENT OF TAX AND REVENUE TO DISCLOSE TO THE DIRECTOR OF PURCHASING APPROPRIATE INFORMATION VERIFYING THAT BIDDER HAS PAID THE REQUIRED BUSINESS TAXES, PROVIDED THAT SUCH INFORMATION DOES NOT CONTAIN THE AMOUNTS OF TAXES PAID NOR ANY OTHER INFORMATION DEEMED BY THE TAX COMMISSIONER TO BE CONFIDENTIAL.</p> <p>UNDER PENALTY OF LAW FOR FALSE SWEARING (WEST VIRGINIA CODE 61-5-3), BIDDER HEREBY CERTIFIES THAT THIS CERTIFICATE IS TRUE AND ACCURATE IN ALL RESPECTS; AND THAT IF A CONTRACT IS ISSUED TO BIDDER AND IF ANYTHING CONTAINED WITHIN THIS CERTIFICATE CHANGES DURING THE TERM OF THE CONTRACT, BIDDER WILL NOTIFY THE</p>						

SEE REVERSE SIDE FOR TERMS AND CONDITIONS

SIGNATURE <i>Joseph M. Shields</i>	TELEPHONE <i>304-623-5670</i>	DATE <i>12/23/07</i>
TITLE <i>Territory Mgr.</i>	FEIN <i>55-0219530</i>	ADDRESS CHANGES TO BE NOTED ABOVE

WHEN RESPONDING TO RFQ, INSERT NAME AND ADDRESS IN SPACE ABOVE LABELED 'VENDOR'



State of West Virginia
 Department of Administration
 Purchasing Division
 2019 Washington Street East
 Post Office Box 50130
 Charleston, WV 25305-0130

Request for Quotation

RFQ NUMBER:
708EC008

PAGE:
8

ADDRESS CORRESPONDENCE TO ATTENTION OF:
**MICHAEL AUSTIN
 304-558-2402**

RFQ COPY
 TYPE NAME/ADDRESS HERE

*Logan Corporation
 Rt. 2 Box 924
 Clarksburg, WV 26301*

**DIVISION OF HIGHWAYS
 EQUIPMENT DIVISION
 ROUTE 33
 BRUSHY FORK ROAD
 BUCKHANNON, WV
 26201 304-472-1750**

DATE PRINTED	TERMS OF SALE	SHIP VIA	FOB	FREIGHT TERMS
11/26/2007				

BID OPENING DATE: **12/27/2007** BID OPENING TIME **01:30PM**

LINE	QUANTITY	UOP	CAT NO	ITEM NUMBER	UNIT PRICE	AMOUNT
<p>PURCHASING DIVISION IN WRITING IMMEDIATELY.</p> <p>BIDDER: <i>Logan Corporation</i></p> <p>DATE: <i>12/23/2007</i></p> <p>SIGNED: <i>Joseph M. Donald</i></p> <p>TITLE: <i>Territory Manager</i></p> <p>* CHECK ANY COMBINATION OF PREFERENCE CONSIDERATION(S) IN EITHER "A" OR "B", OR BOTH "A" AND "B" WHICH YOU ARE ENTITLED TO RECEIVE. YOU MAY REQUEST UP TO THE MAXIMUM 5% PREFERENCE FOR BOTH "A" AND "B". (REV. 12/00)</p> <p>NOTICE</p> <p>A SIGNED BID MUST BE SUBMITTED TO:</p> <p>DEPARTMENT OF ADMINISTRATION PURCHASING DIVISION BUILDING 15 2019 WASHINGTON STREET, EAST CHARLESTON, WV 25305-0130</p> <p>THE BID SHOULD CONTAIN THIS INFORMATION ON THE FACE OF THE ENVELOPE OR THE BID MAY NOT BE CONSIDERED:</p>						

SEE REVERSE SIDE FOR TERMS AND CONDITIONS

SIGNATURE <i>Joseph M. Donald</i>	TELEPHONE <i>304-623-5670</i>	DATE <i>12/23/07</i>
TITLE <i>Territory Mgr.</i>	FEIN <i>55-0219530</i>	ADDRESS CHANGES TO BE NOTED ABOVE

WHEN RESPONDING TO RFQ, INSERT NAME AND ADDRESS IN SPACE ABOVE LABELED 'VENDOR'



State of West Virginia
 Department of Administration
 Purchasing Division
 2019 Washington Street East
 Post Office Box 50130
 Charleston, WV 25305-0130

Request for Quotation

RFQ NUMBER
708EC008

PAGE
9

ADDRESS CORRESPONDENCE TO ATTENTION OF
**MICHAEL AUSTIN
 304-558-2402**

VENDOR

RFQ COPY
 TYPE NAME/ADDRESS HERE

*Logan Corporation
 Rt. 2 Box 924
 Clarksburg, WV 26301*

SHIP TO

**DIVISION OF HIGHWAYS
 EQUIPMENT DIVISION
 ROUTE 33
 BRUSHY FORK ROAD
 BUCKHANNON, WV
 26201 304-472-1750**

DATE PRINTED	TERMS OF SALE	SHIP VIA	F.O.B.	FREIGHT TERMS
11/26/2007				

BID OPENING DATE: **12/27/2007** BID OPENING TIME **01:30PM**

LINE	QUANTITY	UOP	CAT NO	ITEM NUMBER	UNIT PRICE	AMOUNT
SEALED BID						
BUYER:				33		
RFQ. NO.:				708EC008		
BID OPENING DATE:				12/27/2007		
BID OPENING TIME:				1:30 PM		
PLEASE PROVIDE A FAX NUMBER IN CASE IT IS NECESSARY TO CONTACT YOU REGARDING YOUR BID:						
				<i>304-623-5676</i>	-----	
CONTACT PERSON (PLEASE PRINT CLEARLY):						
				<i>Joe Dinaldo</i>	-----	
***** THIS IS THE END OF RFQ 708EC008 ***** TOTAL:						<i>\$29,654.00</i>

SEE REVERSE SIDE FOR TERMS AND CONDITIONS

SIGNATURE *Joseph M. Dinaldo* TELEPHONE *304-623-5670* DATE *12/23/07*
 TITLE *Territory mgr.* FEIN *55-0219530* ADDRESS CHANGES TO BE NOTED ABOVE

WHEN RESPONDING TO RFQ, INSERT NAME AND ADDRESS IN SPACE ABOVE LABELED 'VENDOR'

WEST VIRGINIA DEPARTMENT OF TRANSPORTATION
DIVISION OF HIGHWAYS
EQUIPMENT DIVISION

PROCUREMENT SPECIFICATIONS
NO. 591-2-L

OPEN END CONTRACT
DOUBLE DRUM VIBRATORY ROLLER/COMPACTOR

1.0 PURPOSE

It is the purpose of these specifications to describe a Double Drum Vibratory Roller/Compactor (hereinafter referred to as a "roller" or a "unit") to be purchased for use by the West Virginia Division of Highways (DOH) on an Open End Contract basis.

2.0 BIDDING PROCEDURES

The current purchasing procedures regarding bidding as established by the Department of Administration, Purchasing Division, shall apply. Failure to submit the "Request for Quotation" forms, complete in its entirety and according to directions indicated, may subject the bidder to disqualification. **Each bid submitted shall also be accompanied by a Bidder's Evaluation Report completed in detail.** Addendums in order, along with exception sheets, should be with Bidder's Evaluation Report. **FAILURE TO SUBMIT THE BIDDER'S EVALUATION REPORT, COMPLETE IN ITS ENTIRETY, MAY RESULT IN AUTOMATIC DISQUALIFICATION.**

3.0 SPECIFICATIONS

The specifications named herein, mandatory and non-mandatory, establish the acceptable level of quality only and are not intended to reflect a preference or favor any particular brand or vendor.

3.1 EXCEPTIONS TO NON-MANDATORY SPECIFICATIONS

Exception to a non-mandatory unit specification may be made by the bidder, providing the exception is not available from the manufacturer. **Any such exception must be noted on the bidder's evaluation report and should be accompanied by supporting documentation/literature from the manufacturer.** A summary of exceptions must be prepared by vendor on a separate attachment to the bidder's evaluation report labeled as "Exception to Specifications" and should be provided with the bid. The state reserves the right to determine whether the stated exception does or does not reduce the quality and performance of the unit. Failure to provide information for any exceptions may be grounds for rejection of the bid. The state reserves the right to waive minor irregularities in bids or specifications in accordance with §148-1-4(f) of the WV Legislative Rules and Regulations.

3.2 MANDATORY SPECIFICATIONS

All specifications preceded by "shall and/or must" or are stated as a "minimum and/or maximum" are mandatory. Any bid failing to meet any mandatory item shall be immediately disqualified. Failure to respond in the appropriate evaluation section may also be grounds for immediate disqualification at the discretion of the State.

A mandatory pre-bid conference is scheduled for this equipment purchase as stated in the RFQ. Vendors having products with variations or exceptions in specified mandatory items are expected to address any such variations or exceptions during the pre-bid conference. **The State shall review and consider any such variation or exception, and may at its sole discretion, issue an addendum to change mandatory specifications deemed to be in the State's best interest. Bids from any vendor failing to attend the mandatory pre-bid shall be disqualified. Bids containing any variation or exception to a mandatory specification that was not addressed during the pre-bid conference and accepted by the issuance of an Addendum shall be disqualified.**

4.0 REPRESENTATIVE UNIT FOR TEST

The successful vendor must (if specified) provide DOH one (1) completed representative unit to be observed and evaluated on each order to insure compliance with specification. If requested, the time period for testing and evaluation shall be seven (7) working days following receipt of the unit. DOH will incur no obligation for deterioration of surfaces, finishes, seals, and mechanical or electrical parts on the unit resulting from operation and testing within the limits of these specifications; nor will DOH incur obligation for damage to the unit resulting from failure to meet specifications when due care and attention is given by DOH and testing is done within the limits of these specifications. Failure of the pilot unit to satisfactorily meet specifications as bid shall be cause for cancellation of the purchase order, and return of the delivered unit along with all associated equipment to the vendor at the vendor's expense.

4.1 CONDITION OF UNIT(S) UPON DELIVERY

All units must arrive at the prescribed delivery point having been completely preserviced with oil, lubricants, and coolant. All prescribed precautions pertaining to first operations and break-in of the unit are to be posted conspicuously on the unit for ready observance by the operator.

4.2 DELIVERY

Delivery point of the completely assembled representative unit will be the DOH, Equipment Division, Route 33 at Brushy Fork Road, Buckhannon, West Virginia (26201).

The vendor is responsible for guaranteeing delivery of the completed units within the time specified and agreed to by the State. Delivery is preferred within 120 days after receipt of purchase agreement. The vendor is responsible for establishing and

coordinating delivery terms with allied manufacturers or suppliers. **Delivery terms shall be stated in the bid and the State reserves the right to accept or negotiate such terms.** Failure to reach an agreement may result in rejection of the bid. **The successful bidder shall provide their manufacturer's confirmation of the order to the WVDOH contact person within seven (7) working days after receiving the approved purchase order.**

A completed pilot model for inspection must be provided within 45 calendar days after receipt of the purchase agreement by the successful vendor.

Delivery is an integral part of this specification and failure to comply will be cause to initiate a D.O.T. Administrative Form WV-82, Vendor Performance Form. The WV-82 Form will provide a means of officially notifying the Purchasing Division and the vendor of unsatisfactory performance; such as late deliveries, poor service, inadequate parts supplies, etc.

The decision to initiate subject Form will be at the sole discretion of the D.O.H. Commissioner's established Equipment Review Board.

Issuance of the WV-82 Vendor Complaint Form on unsatisfactory delivery against any vendor will be cause to refuse to consider similar items from those vendors on future Request For Quotations.

(NOTE: Delivery time could be altered due to labor strikes, severe inclement weather conditions, etc.)

5.0 AWARD CRITERIA

- 5.1 DOH will recommend the award in accordance with the RFQ evaluation criteria described in the requisition. **The award shall be made to the lowest unit cost vendor that meets or exceeds the specifications.**

Prices for the units shall be in quantities of 1-10, 11-20, and 21 and over. However, for evaluation purposes, we will use quantities 1-10. DOH reserves the right to place multiple orders in any quantity.

6.0 SPECIFICATIONS AND GUIDELINES - GENERAL

6.1 IDENTIFICATION OF THE UNIT BEING PROPOSED

The bidder must identify the unit by manufacturer, model, series, and year of manufacture, in the bid to enable identification by DOH in the manufacturer's specifications of the proposed unit. The bidder will submit complete descriptive literature of the proposed unit, to establish that the bid is the manufacturer's most current model, including latest engineering improvements, which have been, or will imminently be, regularly advertised and sold on the open market. The unit specified herein and

The successful vendor shall furnish all training aids; i.e., videos, projectors, etc. required in conducting the training.

Manufacturers and/or dealers will be required to submit to the Equipment Division, in addition to the operating and service manuals, booklets and pamphlets explaining the Preventive Maintenance and Operator Procedures to be used by the operators of this equipment, and must include such things as daily prestart inspection procedure, service schedule, and routine maintenance required, safety precautions, etc.

6.4 PREVENTIVE MAINTENANCE AND OPERATOR PROCEDURES:

The seminar to be held at the W. Va. Division of Highways, Equipment Division, Buckhannon, West Virginia.

Manufacturers and/or dealers shall be required to furnish the Training Academy with one (1) Operator's Manual to be shipped direct to Letha Lamb, WVD0H Training Academy, Post Office Box 610, Buckhannon, West Virginia 26201 prior to delivery of the pilot.

Manufacturers and/or dealers will be required to stage a thorough seminar on the subjects of Preventative Maintenance, Operator and Mechanic Training. In order to keep the operators and mechanics updated, the successful vendor shall conduct training with each purchase order against this open end contract. Training is preferred within 2 working days after delivery of the pilot unit on the individual purchase order.

6.3 TRAINING:

* NOTE: MANUALS SHALL BE DELIVERED UPON COMPLETION OF DELIVERY OF TOTAL UNITS. FAILURE TO DO SO WILL DELAY PAYMENT.

An operator's manual must be included with each unit upon delivery. A "line sheet" (if applicable) and Equipment Preventative Maintenance Questionnaire (as shown in X6.2 of the Bidder's Evaluation Report) must be with pilot unit upon delivery. In addition, there must be 12 service, shop, or maintenance manuals; ten (10) to be distributed to the Districts and two (2) for the Equipment Division. Also, there must be 14 parts manuals; ten (10) to be distributed to the Districts and four (4) for Equipment Division use. CD ROM is preferred in lieu of parts manuals.

6.2 OPERATING AND SERVICE MANUALS AND PARTS LISTS

offered to be manufactured after January 1, 2007 and be clearly identified and marked with date of manufacture.

6.5 WARRANTY AND SERVICE POLICY

The Manufacturers warranty or service policy is to apply to the unit. Such warranty or service policy is to be recognized at any authorized unit dealer, representing manufacturer of proposed unit throughout the State of West Virginia. The applicable warranty or service policy will not be contingent upon obtaining routine service, lubrication, and servicing of the unit from factory authorized agencies. It will be the responsibility of the bidder to have available labor to repair or replace any defective replacement parts, components and materials, and to have available those replacement parts, components, and/or materials found to be defective during the terms of the warranty period. The bidder should state the labor rates, locations where parts will be stocked, availability of parts, and discounts offered for parts, when terms of the warranty offer a pro-rated cost for parts and labor. In addition, the successful bidder should offer field work to repair or replace defective parts, components, and materials found to be defective during the terms of the warranty and should provide mechanic's travel rates, mileage charges, field mechanic rates, and any surcharge for miscellaneous items, if applicable, for field work during the warranty period. Submit to Division of Highways any technical or engineering improvements during the term of the warranty. **The unit must be accompanied upon delivery by the unit's manufacturer's executed warranty or service policy.**

A mandatory minimum two (2) year bumper to bumper basic parts and labor warranty is required for this unit.

THE "WARRANTY AND SERVICE POLICY QUESTIONNAIRE" ATTACHED IN THE BIDDER'S EVALUATION REPORT MUST BE COMPLETED IN ITS ENTIRETY AND SUBMITTED WITH YOUR BID. (SEE SECTION X6.5 OF BIDDER'S EVALUATION REPORT).

6.6 EVALUATION COMMITTEE REQUIREMENTS

Detailed component specifications, product literature, component models, required for specification compliance determination by the Evaluation Committee should be provided with each bid. Any information supplied that is contrary to/or conflicting with the specifications and/or attached Bidders Evaluation Report may be sufficient cause for rejection of bid.

6.7 UNSPECIFIED ACCESSORIES & FEATURES

All parts, equipment, accessories, material, design and performance characteristics not specified herein, but which are necessary to provide a complete unit, must be furnished with each unit and required to conform to strength, quality of material,

and quality of workmanship to those which are advertised and provided to the market in general by the unit industry.

All parts and accessories advertised and regularly supplied as standard shall be included, except those which would represent duplication of these specified, and except those which, by specification, are not to be furnished. All standard safety features, required by Federal and State Law, shall be included.

- 7.0 SPECIFICATIONS OF THE QUOTED UNIT ARE AS FOLLOWS:
- 7.1 **Roller(s) shall be equipped with ROPS and FOPS canopy.**
- 7.2 **Engine shall be manufacturers water/air cooled diesel powered and shall provide a minimum of 28 horsepower and sufficient torque to operate machine and hydraulic system at maximum efficiency.**
- 7.3 **Steering system shall be of hydraulic, full power, articulated design.**
- 7.4 **Unit shall be of a low profile design.**
- 7.5 **Unit weight to be approximately 6000 pounds.**
- 7.6 **Wheel base to be approximately 68 inches.**
- 7.7 **Roller(s) shall have dual drum drive with hydrostatic propulsion.**
- 7.8 **Unit shall be equipped with manufacturers vandalism package.**
- 7.9 **Unit shall travel 0 to 6 M.P.H. forward and reverse minimum.**
- 7.10 **Engine:**
- 7.10.1 **Engine to have a manufacturer's heaviest duty dual fuel filtering system offered.**
- 7.10.2 **Full pressure lubrication with oil filter and oil by-pass system.**
- 7.10.3 **Manufacturers standard governor with key shut off, wire sealed by manufacturer.**
- 7.10.4 **Cooling system shall be filled with permanent type Dex-Cool extended life (or equal) anti-freeze protected to a point of -34° F if unit is water cooled.**
- 7.11 **Brakes:**
- 7.11.1 **Service brake to be through hydrostatic propulsion system.**

7.11.2 Parking brake to be of spring-applied, hydraulically released on each drum drive.

7.12 Drums:

7.12.1 **Drums shall be of manufacturer's heavy duty design.**

7.12.2 Drum width approximately 48 inches.

7.12.3 Drum diameter approximately 28 inches.

7.12.4 **Wiper bars shall be mounted front and rear of each drum.**

7.12.5 **Wiper bars shall be spring loaded, self adjusting.**

7.12.6 **Wiper bars shall have replaceable rubber/neoprene drum cleaners.**

7.12.7 **Front and rear drums shall be of vibratory compaction type.**

7.12.8 **Vibrating parts must be isolated from rest of roller.**

7.12.9 **Vibrating system isolators shall be replaceable.**

7.12.10 **Unit must be equipped with automatic vibration switch.**

7.13 Electrical:

7.13.1 **Electrical system shall be manufacturer's heavy duty 12 volt D.C. negative ground.**

7.13.2 **Manufacturers recommended heavy duty maintenance free battery shall be provided.**

7.13.3 **Battery CCA 500 minimum.**

7.13.4 Alternator to be 65 AMP with internal regulator.

7.14 Gauges to be illuminated and to be equipped with visual or audible warning that will advise operator when manufacturer recommended safe operating ranges are exceeded.

7.14.1 **Unit shall be provided with hour meter operable from engine operation (not key switch.)**

7.14.2 Ignition switch water sealed.

7.14.3 Fuel gauge.

- 7.14.4 Volt/Amp meter gauge or light.
- 7.14.5 Oil pressure gauge or light.
- 7.14.6 Engine temperature gauge or light
- 7.14.7 Operators station to have manufacturer's fully adjustable isolation mounted seat with seat belt.
- 7.14.8 **OSHA approved back-up alarm shall be provided and installed by manufacturer.**
- 7.14.9 Unit to have a parking brake "on" indicator.
- 7.14.10 **A neutral start safety switch shall be provided.**
- 7.15 Water System:
 - 7.15.1 Tank capacity to be 50 gallon approximately.
 - 7.15.2 **Water system shall be pressurized.**
 - 7.15.3 **Water flow must be variable.**
 - 7.15.4 **Water filter(s) shall be provided in system.**
 - 7.15.5 Screened back nozzle type sprayers for drums.
 - 7.15.6 Empty water tank indicator to be provided.
 - 7.15.7 **Water pump shall be capable of "Run Dry" situation without damage to pump or components.**
 - 7.15.8 **Water tank and complete water system shall be constructed of rust proof materials.**
 - 7.15.9 **Water tank shall have drain plug.**
- 7.16 Lighting:
 - 7.16.1 **Unit shall be equipped with flashers visible from front and rear of roller.**
 - 7.16.2 **Work lights shall be installed front and rear of roller. Two (2) front and two (2) rear.**

- 7.16.3 Low profile high intensity dual flash strobe light shall be mounted on top of cab/canopy. Aero Flash Model number M420 or equivalent. (Amber in color)**
- 7.17 Unit shall be delivered to WV DOH with all manufacturers recommended safety related decals and safety features intact.**
- 7.18 One (1) complete set of replacement filters shall be provided with each unit upon delivery.**
- 7.19 Paint:**
- 7.19.1 The Manufacturer's recommended paint preparation and color to be provided.**
- 7.20 Vendor must certify that roller offered will meet or exceed the "Occupational Safety and Health Act of 1970" or subsequent changes that are in effect at time of manufacturer of unit.**
- 7.21 Advertising: Only one (1) manufacturer name plate, which must include model number, may appear on exterior of unit. Logos created through the stamping or casting process of manufacturer are also acceptable. No logo will interfere with the Department's striping and logo.**
- 7.22 Preventive Maintenance and Operators Orientation/Training:**
- 7.22.1 The Manufacturer or Dealer shall provide preventive maintenance/operator orientation seminar to be conducted at the Equipment Division, Buckhannon. The successful vendor shall furnish all training aids; i.e. videos, projectors, etc., required in conducting the training.**

WEST VIRGINIA DEPARTMENT OF TRANSPORTATION
DIVISION OF HIGHWAYS
EQUIPMENT DIVISION

BIDDER'S EVALUATION REPORT

PROCUREMENT SPECIFICATIONS FOR OPEN END CONTRACT
NO. 591-2-L

OPEN END CONTRACT
DOUBLE DRUM VIBRATORY ROLLER/COMPACTOR

NOTE TO BIDDER: Procurement Specification No. 591-2-L, Paragraph 2.0 recommends the completion and submittal of this Report with your bid. Purpose of this Report is to enable the West Virginia Division of Highways Evaluation Committee to make full and fair evaluation of the bid. Addendums in order, along with exception sheets, should be with Bidder's Evaluation Report.
FAILURE TO SUBMIT THIS REPORT, COMPLETE IN ITS ENTIRETY, MAY SUBJECT THE BIDDER TO DISQUALIFICATION.

Reference Requisition No.: 708EC008

Bidder's Name: Logan Corporation

Address: Rt. 2 Box 924 Clarksburg, WV 26301

Telephone Number: 304-623-5670

Years Bidder has been registered to do business with the State of West Virginia: 33 YRS.

Years Company has been an authorized dealer for proposed unit: 4 YRS.

X3.2 Have you complied with all mandatory specifications? YES NO

X4.2 DELIVERY:

X4.2.1 Delivery date of completed representative unit: 45 Calendar Days After
Receipt of Purchase Agreement

X4.2.2 Delivery date of balance of completed units: 120 Calendar Days After Receipt of
Purchase Agreement



TEREX CONSTRUCTION AMERICAS NEW PRODUCT WARRANTY

TEREX CORPORATION d/b/a TEREX CONSTRUCTION AMERICAS, hereafter referred to as TCA, warrants its new Products to be free, under normal use and service, of any defects in manufacture or materials for the period of 12 months from (a) delivery to, and placement into service by the first user or (b) delivery to the first retail purchaser, whichever occurs first; provided that TCA receives written notice of the defect within thirty (30) days of its discovery and Buyer establishes that (i) the equipment has been maintained and operated within the limits of rated and normal usage; and (ii) the defect did not result in any manner from the intentional or negligent action or inaction by Buyer, its agents or employees. If requested by TCA, Buyer must return the defective equipment to a TCA authorized distributor and defective parts to TCA, and if Buyer cannot establish that conditions (i) and (ii) above have been met, then this warranty shall not cover the alleged defect.

The term "Products" shall include only the following equipment sold by TCA: SCL, SKL and SKS model wheel loaders, HR, HML and HS, S1 and S2 model excavators, rollers and backhoes.

Delivery inspection forms are required for warranty validation and processing.

TCA's obligation and liability under this warranty is expressly limited to, at TCA's sole option, repairing or replacing, with new or remanufactured parts or components, any part, which appears to TCA upon inspection to have been defective in manufacture or materials. Such parts shall be provided at no cost to the owner, FOB TCA's parts facility.

This warranty shall be null and void if parts (including wear parts) other than genuine OEM TCA parts are used in the equipment.

Accessories, assemblies and components included in the TCA equipment, which are not manufactured by TCA, are subject to the warranty of their respective manufacturers. Normal maintenance, adjustments, or maintenance/wear parts are not covered by this warranty and are the sole maintenance responsibility of Buyer.

TCA makes no other warranty, express or implied, and makes no warranty of merchantability or fitness for any particular purpose.

No employee or representative is authorized to modify this warranty unless such modification is made in writing and signed by an authorized officer of TCA.

TCA's obligation under this warranty shall not include duty, taxes, or any other charges whatsoever, or any liability for direct, indirect, incidental, or consequential damages.

Improper maintenance, improper use, abuse, improper storage, operation beyond rated capacity, operation after discovery of defective or worn parts, or alteration or repair of the equipment by persons not authorized by TCA shall render this warranty null and void. TCA reserves the right to inspect the installation of the Product and review maintenance procedures to determine if the failure was due to improper maintenance, improper use, abuse, improper storage, operation beyond rated capacity, operation after discovery of defective or worn parts, or alteration or repair of the equipment by persons not authorized by TCA.

TCA reserves the right to make improvements or changes to its Products without incurring any obligation to make such changes or modifications to Products previously sold.

Parts Warranty: TCA warrants the parts ordered from the Parts Department to be free of defect in manufacture or materials for a period of 90 days from date of purchase from TCA.

TRANSFERABILITY OF WARRANTY: The unexpired portion of this warranty may be transferred, provided that (i) the warranty has not been voided or breached by the transfer or prior to transfer, (ii) TCA has received warranty registration for the relevant Product and (iii) the transferee completes and returns to TCA the appropriate warranty transfer documentation which shall be provided upon request. Please contact your local TCA Distributor for additional details if needed.

IN THE EVENT OF ANY BREACH OF THE WARRANTY BY TCA, TCA'S LIABILITY SHALL BE LIMITED EXCLUSIVELY TO THE REMEDIES (AT TCA'S SOLE OPTION) OF REPAIR OR REPLACEMENT OF ANY DEFECTIVE EQUIPMENT COVERED BY THE WARRANTY. IN NO EVENT SHALL TCA, OR ANY SUBSIDIARY OR DIVISION THEREOF BE LIABLE FOR INCIDENTAL, INDIRECT, CONSEQUENTIAL OR OTHER DAMAGES OR LOSSES RESULTING FROM A BREACH OF WARRANTY INCLUDING, WITHOUT LIMITATION, LABOR COSTS, LOSS OF USE OF OTHER EQUIPMENT, THIRD PARTY REPAIRS, PERSONAL INJURY, EMOTIONAL OR MENTAL DISTRESS, IMPROPER PERFORMANCE OR WORK, PENALTIES OF ANY KIND, LOSS OF SERVICE OF PERSONNEL, OR FAILURE OF EQUIPMENT TO COMPLY WITH ANY FEDERAL, STATE OR LOCAL LAWS.

ITEMS NOT COVERED BY TCA WARRANTY

The following items are NOT covered under the TCA Warranty (the following list is not exhaustive):

1. Items sold by any individual, corporation, partnership or any other organization or legal entity that is not an authorized TCA Distributor.
2. Components which are not manufactured by TCA are not covered by TCA's warranty. Such components are covered only by the warranty that is provided by the manufacturer of such components. Such components include, but are not limited to, engines, electric motors, air compressors, air conditioners, batteries, tires etc.
3. Replacement of assemblies: TCA has the option to repair or replace any defective part or assembly. It is TCA's policy to refuse claims for the replacement of a complete assembly that is field repairable by the replacement or repair of defective part(s) within the assembly.
4. Normal Operational Maintenance Services and Wear Parts: Maintenance services and wear parts are excluded from warranty claims. Maintenance services not covered include, but are not limited to, such items as: tune-up, lubrication, fuel or hydraulic system cleaning, brake inspection or adjustment, or the replacement of any service items such as filters or brake linings made in connection with normal maintenance services.
5. Transportation: Any damage caused by carrier handling is a transportation claim and should be filed immediately with the respective carrier. Travel and mileage costs are not covered under this warranty.
6. Deterioration: Work required or parts exposed as the result of age, storage, weathering, lack of use, demonstration use.
7. Secondary Failures: Should the Buyer continue to operate a machine after it has been noted that a failure has occurred, TCA will not be responsible under the warranty for resultant damage to other parts due to that continued operation.
8. Workmanship of Others: TCA does not accept responsibility for improper installation or labor costs of personnel other than authorized TCA Distributor personnel.
9. Stop and Go Warranty: TCA does not recognize "Stop and Go" warranties; after the period of warranty commences, it shall not be tolled for any reason.
10. Incidental or Consequential Damage: TCA shall not be liable for any Incidental or Consequential Damages of any kind, including, but not limited to, lost profits, loss of production, increased overhead, loss of business opportunity, delays in production, costs of replacement components and increased costs of operation that may arise from the breach of this warranty. Customer's sole remedy shall be limited to (at TCA's sole option) repair or replacement of the defective part.
11. Diagnostic Labor: TCA shall not be responsible for diagnostic labor, travel mileage, travel labor or related travel expenses (such as meals and lodging); overtime or premium labor rates.

THIS WARRANTY IS EXPRESSLY IN LIEU OF AND EXCLUDES ALL OTHER WARRANTIES, EXPRESS OR IMPLIED (INCLUDING THE WARRANTIES OF MERCHANTABILITY AND FITNESS FOR A PARTICULAR PURPOSE) AND ALL OTHER OBLIGATIONS OR LIABILITY ON TCA'S PART. THERE ARE NO WARRANTIES THAT EXTEND BEYOND THE LIMITED WARRANTY CONTAINED HEREIN. TCA neither assumes nor authorizes any other person to assume for TCA any other liability in connection with the sale of TCA's equipment. This warranty shall not apply to any of TCA's equipment or any part thereof which has been subject to misuse, alteration, abuse, negligence, accident, acts of God or sabotage. No action by any party shall operate to extend or revive this limited warranty without the prior written consent of TCA.

TEREX CONSTRUCTION AMERICAS

Southaven, MS 38671 USA

August 2004

X5.0 AWARD CRITERIA;

X5.1 Prices for unit in quantities of

1-10	<u>\$ 29,654.⁰⁰</u> per unit
11-20	_____ per unit
21 and over	_____ per unit

↓

X6.0 SPECIFICATIONS - GENERAL

X6.1 Manufacturer, model, series, and date of manufacture of proposed unit:

Terex Model TV-1200 2008 units
 Is descriptive literature, fully describing proposed unit attached to your bid? YES _____ NO

If not, why? _____

X6.2 Will the required number of service manuals, and complete parts list be delivered to the Equipment Division at Buckhannon upon completion of delivery of total units?

YES _____ NO

Will the required Equipment Preventive Maintenance Form (Section X6.2 of Bidders Evaluation Report) be provided upon inspection of the pilot unit?

YES _____ NO

X6.2
2-10-00

EQUIPMENT PREVENTATIVE MAINTENANCE QUESTIONNAIRE

THIS FORM MUST BE COMPLETED IN ITS ENTIRETY BY SUCCESSFUL BIDDER OR MANUFACTURER=S TECHNICAL REPRESENTATIVE PRIOR TO DELIVERY OF PILOT MODEL TO THE WVD0H.

DESCRIPTION: _____ MAKE: _____
MODEL: _____ YEAR: _____ PURCHASE AMOUNT: _____

ENGINE: MAKE: _____ MODEL: _____ FUEL TYPE: _____
HORSEPOWER: _____ CYLINDER: _____ ENGINE SERIAL: _____
COOLING SYSTEM CAPACITY: _____

BELTS: DESCRIPTION: _____ PART NUMBERS: _____

GVW: _____ AXLE CAPACITY: FRONT: _____ REAR: _____

TIRES: FRONT MAKE & SIZE: _____
REAR MAKE & SIZE: _____

DIMENSIONS OF UNIT: LENGTH: _____ WIDTH: _____ LENGTH: _____

VENDOR CONTACT PERSON: _____ PHONE: _____

PARTS:

BATTERY MAKE: _____ MODEL: _____ CCA: _____
TOP OR SIDE POST: _____ DIMENSIONS: LENGTH _____ WIDTH _____ HEIGHT _____
SPARK PLUGS OR FUEL INJECTORS MAKE: _____ PART # _____
FUEL PUMP OR INJECTION PUMP MAKE: _____ MODEL: _____
ALTERNATOR MAKE: _____ PART #: _____
STARTER MAKE: _____ PART #: _____
TURBO CHARGER MAKE: _____ PART #: _____
TRANS. MAKE: _____ MODEL: _____ AUTO/MANUAL: _____
HYDRAULIC PUMP MAKE: _____ MODEL: _____

FILTERS	MAKE	PART NO.	LUBRICANT	MANUFACTURER TYPE
OIL	_____	_____	ENGINE	_____
AIR INNER	_____	_____	TRANSMISSION	_____
AIR OUTER	_____	_____	POWER STEERING	_____
FUEL PRIMARY	_____	_____	HYDRAULIC	_____
FUEL SECONDARY	_____	_____	DIFFERENTIALS	_____
COOLANT	_____	_____	BRAKE FLUID	_____
HYDRAULIC	_____	_____	COOLANT	_____
OTHER	_____	_____	OTHER	_____

X6.3 TRAINING:

Will training seminar be conducted on Preventive Maintenance, Operator and Mechanic Training YES NO

Will you conduct training with each purchase order against this open end contract? YES NO

Will training be conducted within 2 working days from the delivery of the pilot unit on the individual purchase order? YES NO

If NO, explain time frame _____

Will an Operator's Manual be furnished directly to Letha Lamb, Training Academy prior to the delivery of the pilot? YES NO

X6.4 If you are the successful vendor, will you furnish all training aids, i.e., videos, projectors, required in conducting the training? YES NO

X6.4.1 Will all manuals, booklets, etc. explaining preventive maintenance, operator procedures, and service schedule be delivered with each unit? YES NO
If NO, explain _____

X6.5 WARRANTY AND SERVICE POLICY

Will the warranty and service you provide comply with all areas as stated in Section 6.5 of specifications YES NO

Is warranty literature attached? YES NO

Is a minimum two (2) year bumper to bumper basic parts and labor warranty included? YES NO

Describe:

X6.6 EVALUATION COMMITTEE REQUIREMENTS

Is all component specifications, product literature, component models provided for Evaluation Committee bid determination? YES NO

X6.7 Will all parts, equipment, accessories, material, design and performance characteristics not specified herein, but which are necessary to provide a complete unit, be furnished with the unit and conform in strength, quality of material, and quality of workmanship to those which are advertised and provided to the market in general by the unit industry?

YES NO

X6.7.1 Are all parts and accessories adequate and regularly supplied as standard to be included except those which may be duplications of specifications herein, and except these by specification are not to be furnished?

YES NO

X6.7.2 Are all standard safety features that are required by Federal and State statutes of law included?

YES NO

X7.0 SPECIFICATIONS OF THE QUOTED UNIT

The bidder should complete the following schedule in order for the Division to compare the actual bid unit to the specifications. Should the bidder except a requirement, then such exception may be only on the basis that such feature is not offered by the manufacturer. The Division will have the sole discretion as to whether the bidder's substitution meets the requirements of the specifications.

Manufacturer: Terex Model: TV-1200-1

X7.1 Are roller(s) equipped with ROPS and FOPS canopy? YES NO

X7.2 Is engine manufacturer's water/air cooled diesel powered? YES NO

HP: 33 and has sufficient torque to operate machine and hydraulic system at maximum efficiency

YES NO

X7.3 Is steering of hydraulic, full power, articulated design? YES NO

X7.4 Is unit a low profile design? YES NO

X7.5 Unit weight: 6382 pounds

X7.6 Wheel base: 65.94 inches

X7.7 Does unit have dual drum drive with hydrostatic propulsion? YES NO

X7.8 Is unit equipped with manufacturer's vandalism package? YES NO

X7.9 Unit has travel 0 MPH to 7.2 MPH forward and reverse

X7.10 Engine:

- X7.10.1 Is manufacturer heaviest duty dual fuel filtering system offered? YES ___ NO
- X7.10.2 Has full pressure lubrication with oil filter and oil by pass system? YES ___ NO
- X7.10.3 Is governor manufacturer's standard with key shut off, wire sealed by manufacturer? YES ___ NO
- X7.10.4 Is cooling system filled with permanent type Dex-Cool extended life (or equal) to a freeze point of -34° if unit is water cooled YES ___ NO

X7.11 Brakes:

- X7.11.1 Is service brake through hydrostatic propulsion system YES ___ NO
- X7.11.2 Is parking brake spring-applied, hydraulically released on each drum drive? YES ___ NO

X7.12 Drums:

- X7.12.1 Are drums manufacturers heavy duty design YES ___ NO
- X7.12.2 Drum width: 47.24 inches
- X7.12.3 Drum diameter: 27.56 inches
- X7.12.4 Are wiper bars mounted front and rear of each drum? YES ___ NO
- X7.12.5 Are wiper bars spring loaded, self adjusting YES ___ NO
- X7.12.6 Do wiper bars have replaceable rubber/neoprene drum cleaners? YES ___ NO
- X7.12.7 Are front and rear drums of vibratory compaction type? YES ___ NO
- X7.12.8 Are vibrating parts isolated from rest of roller? YES ___ NO
- X7.12.9 Are vibrating system isolators replaceable? YES ___ NO
- X7.12.10 Will unit be equipped with automatic vibration switch? YES ___ NO

X7.13 Electrical:

- X7.13.1 Does electrical system have manufacturer's heavy duty 12 volt D.C. negative ground? YES ___ NO
- X7.13.2 Is manufacturers recommended heavy duty maintenance free battery provided? YES ___ NO
- X7.13.3 Battery CCA: 770
- X7.13.4 Alternator: 65 AMP with internal regulator

X7.16 Lighting:

X7.16.1 Is unit equipped with flashers visible from front and rear of roller YES NO

X7.16.2 Are work lights installed front and rear of roller YES NO

Are there 2 in front and two in rear YES NO

X7.16.3 Is a low profile high intensity dual flash strobe light mounted on top of cab/canopy YES NO

Manufacturer: _____ Model: _____

X7.17 Will unit be delivered to WVDOH with all manufacturers recommended safety related decals and safety features intact YES NO

X7.18 Is one (1) complete set of replacement filters provided with each unit upon delivery? YES NO

X7.19 Paint:

X7.19.1 Is manufacturer's recommended paint preparation and color provided? YES NO

X7.20 Does vendor certify that roller offered meets or exceed the "OSHA of 1970" or changes that are in effect at time of manufacturer of unit? YES NO

X7.21 Does unit conform to the advertising guidelines? YES NO

X7.22 Preventive Maintenance and Operators Orientation/Training:

X7.22.1 Have you attached a copy of proposed training program along with schedule of course. Will you furnish all training aids? YES NO

STATE OF WEST VIRGINIA
Purchasing Division

PURCHASING AFFIDAVIT

West Virginia Code §5A-3-10a states: No contract or renewal of any contract may be awarded by the state or any of its political subdivisions to any vendor or prospective vendor when the vendor or prospective vendor or a related party to the vendor or prospective vendor is a debtor and the debt owed is an amount greater than one thousand dollars in the aggregate

DEFINITIONS:

"Debt" means any assessment, premium, penalty, fine, tax or other amount of money owed to the state or any of its political subdivisions because of a judgment, fine, permit violation, license assessment, defaulted workers' compensation premium, penalty or other assessment presently delinquent or due and required to be paid to the state or any of its political subdivisions, including any interest or additional penalties accrued thereon.

"Debtor" means any individual, corporation, partnership, association, limited liability company or any other form or business association owing a debt to the state or any of its political subdivisions. "Political subdivision" means any county commission; municipality; county board of education; any instrumentality established by a county or municipality; any separate corporation or instrumentality established by one or more counties or municipalities, as permitted by law; or any public body charged by law with the performance of a government function or whose jurisdiction is coextensive with one or more counties or municipalities. "Related party" means a party, whether an individual, corporation, partnership, association, limited liability company or any other form or business association or other entity whatsoever, related to any vendor by blood, marriage, ownership or contract through which the party has a relationship of ownership or other interest with the vendor so that the party will actually or by effect receive or control a portion of the benefit, profit or other consideration from performance of a vendor contract with the party receiving an amount that meets or exceed five percent of the total contract amount.

EXCEPTION: The prohibition of this section does not apply where a vendor has contested any tax administered pursuant to chapter eleven of this code, workers' compensation premium, permit fee or environmental fee or assessment and the matter has not become final or where the vendor has entered into a payment plan or agreement and the vendor is not in default of any of the provisions of such plan or agreement.

LICENSING: Vendors must be licensed and in good standing in accordance with any and all state and local laws and requirements by any state or local agency of West Virginia, including, but not limited to, the West Virginia Secretary of State's Office, the West Virginia Tax Department, West Virginia Insurance Commission, or any other state agencies or political subdivision. Furthermore, the vendor must provide all necessary releases to obtain information to enable the Director or spending unit to verify that the vendor is licensed and in good standing with the above entities.

CONFIDENTIALITY: The vendor agrees that he or she will not disclose to anyone, directly or indirectly, any such personally identifiable information or other confidential information gained from the agency, unless the individual who is the subject of the information consents to the disclosure in writing or the disclosure is made pursuant to the agency's policies, procedures and rules. Vendors should visit www.state.wv.us/admin/purchase/privacy for the Notice of Agency Confidentiality Policies.

Under penalty of law for false swearing (West Virginia Code, §61-5-3), it is hereby certified that the vendor acknowledges the information in this said affidavit and are in compliance with the requirements as stated.

Vendor's Name: Logan Corporation

Authorized Signature: Joseph M. Donalds Date: 12/23/07



TEREX®

TV1000-1 TV1200-1

Tandem Asphalt Rollers

OPERATING WEIGHT	5,644 / 6,382 lbs (2,560 / 2,895 kg)
NET ENGINE POWER	33 hp (24.5 kW)
STATIC LINEAR LOAD	71.7 / 67.5 lbs/in (12.0 / 13.9 kg/cm)
CENTRIFUGAL FORCE	5,397 / 6,776 lbs (24.0 / 30.4 kN)

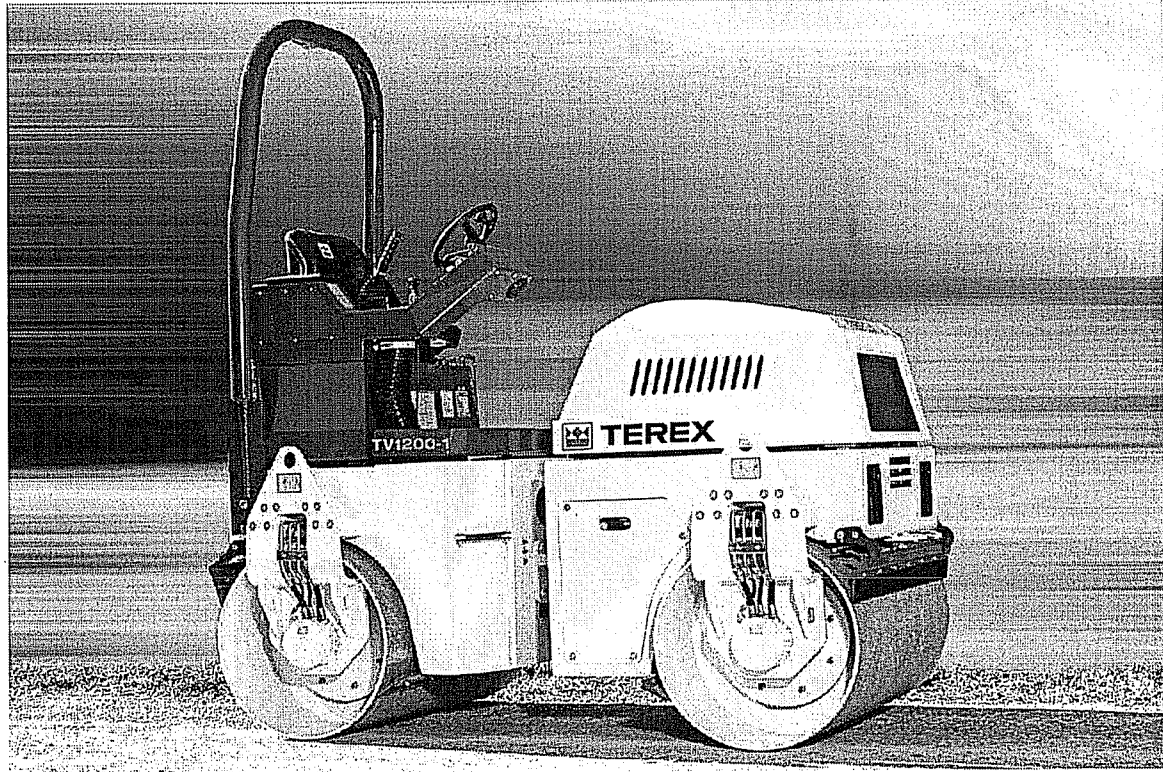

TANDEM ASPHALT
ROLLER

Operating Data, Standard Equipment

	TV1000-1	TV1200-1
Operating weight	5,644 lbs (2,560 kg)	6,382 lbs (2,895 kg) ✓
Basic weight	5,238 lbs (2,376 kg)	5,977 lbs (2,711 kg)
Static linear load	71.7 lbs/in (12.0 kg/cm)	67.5 lbs/in (13.9 kg/cm)
Total length	93.5 in (2,375 mm)	93.5 in (2,375 mm)
Total width	42.12 in (1,070 mm)	50 in (1,270 mm)
Turning radius (inside)	103 in (2,625 mm)	99 in (2,525 mm)
Total height	104.33 in (2,650 mm)	104.33 in (2,650 mm)
Frame articulation degrees	30°	30°
Frame oscillation degrees	15°	15°
Frequency (Hz) VPM	3,120 (51 Hz)	3,120 (51 Hz)
Amplitude	.022 in (0.6 mm)	.022 in (0.6 mm)
Centrifugal Force	5,397 lbs (24.0 kN)	6,776 lbs (30.4 kN)
Gradeability % (with vibration on)	30%	30%
Gradeability % (with vibration off)	40%	40%
Drum thickness	.78 in (20 mm)	.51 in (13 mm)

Tandem Asphalt Rollers TV1000-1 & TV1200-1

Specifications

Engine

Manufacturer, model	Kubota, D1703-M
Type	3-cylinder, diesel engine
Power rating at 2,500 rpm	33 hp (24.5 kW)
Cooling system	Air ✓

Electrical System

Nominal voltage	12 Volt
Battery	770 CCA
Alternator	65 Amp

Hydrostatic Transmission

Hydrostatic drive. Forward and reverse selected from joystick. Infinitely variable speed control forward and reverse. 0 – 7.2 mph (0 – 11.6 km/h)

Drive

Dual radial piston drive motors.

Brakes

Service brake: Hydrostatic drive provides dynamic braking.

Parking brake: Spring applied brakes.

Steering

Heavy-duty articulated steering

Fluid Capacities

Fuel tank	11.6 gal (44 L)
Hydraulic system (includes tank)	11.6 gal (44 L)
Water tank	47.5 gal (180 L)

Operator's Area

Open operator's seat with functional design, excellent all-round visibility and user-friendly operator controls.

Operator's suspension seat with hydraulic cushioning and lap belt; weight, height and longitudinally adjustable.

Standard Features

Vandal protection package
Back-up alarm
2 scraper bars per drum
Hydraulic test points
Electrical diagnostics system (LED lights)
Tow valve
12 volt battery disconnect
Pressure and gravity water
ROPS

Dimensions

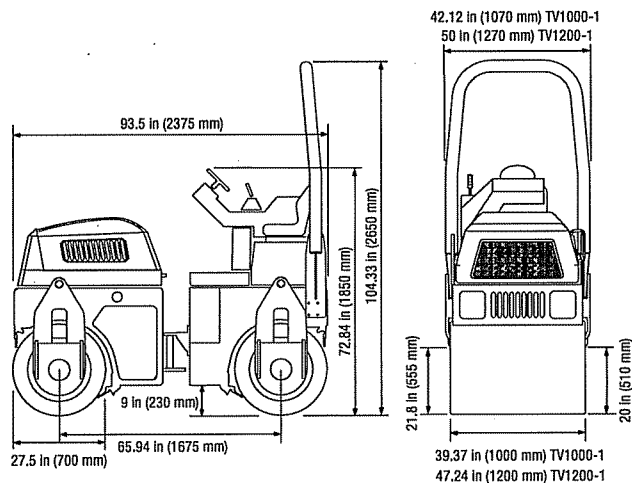

Terex Construction Americas

8800 Rostin Road
Southaven, MS 38671
USA

TEL 662-393-1800
SALES 866-837-3923
PARTS & TECH SUPPORT 888-201-6008
FAX 662-393-1700
EMAIL sales@terexca.com
WEB terexca.com

For more information, product demonstration, or details on purchase, lease and rental plans, please contact your local Terex Distributor.

Effective Date: April 1, 2007. Product specifications and prices are subject to change without notice or obligation. The photographs and/or drawings in this document are for illustrative purposes only. Refer to the appropriate Operator's Manual for instructions on the proper use of this equipment. Failure to follow the appropriate Operator's Manual when using our equipment or to otherwise act irresponsibly may result in serious injury or death. The only warranty applicable to our equipment is the standard written warranty applicable to the particular product and sale and Terex makes no other warranty, express or implied. Products and services listed may be trademarks, service marks or trade-names of Terex Corporation and/or its subsidiaries in the USA and other countries and all rights are reserved. Terex® is a registered trademark of Terex Corporation in the USA and many other countries. Copyright © 2007 Terex Corporation.



CLARKSBURG
212 NORTH OHIO AVENUE
RT. 2 BOX 924
CLARKSBURG, WV 26301
PHONE: (304) 623-5670
1-800-473-0110
FAX: (304) 623-5676
www.logancorp.com

RE: RFQ# 708EC008

PROPOSED TRAINING PROGRAM

Logan Corporation will provide an Operator and Service Training Program to be conducted at the WVDOH training facility at Buckhannon, WV

Training will include both the operation and service of the Terex TV-1200 Double Drum Asphalt roller. Representatives from both Logan Corporation and Terex will be on site for the training.



State of West Virginia
 Department of Administration
 Purchasing Division
 2019 Washington Street East
 Post Office Box 50130
 Charleston, WV 25305-0130

Request for Quotation

RFQ NUMBER
708EC008

PAGE
1

ADDRESS CORRESPONDENCE TO ATTENTION OF
**MICHAEL AUSTIN
 304-558-2402**

RFQ COPY
 TYPE NAME/ADDRESS HERE

*Logan Corporation
 Rt. 2 Box 924
 Clarksburg, WV 26301*

DIVISION OF HIGHWAYS
 EQUIPMENT DIVISION
 ROUTE 33
 BRUSHY FORK ROAD
 BUCKHANNON, WV
 26201 304-472-1750

DATE PRINTED	TERMS OF SALE	SHIP VIA	F.O.B.	FREIGHT TERMS
12/17/2007	Net 30	Motor Truck	Buckhannon, WV	Prepaid
BID OPENING DATE: 12/27/2007		BID OPENING TIME 01:30PM		

LINE	QUANTITY	UOP	CAT NO	ITEM NUMBER	UNIT PRICE	AMOUNT
ADDENDUM NO. 1						
CHANGES TO THE SPECIFICATIONS, DELETE THE FOLLOWING:						
PURCHASING CARD ACCEPTANCE: THE STATE OF WEST VIRGINIA CURRENTLY UTILIZES A VISA PURCHASING CARD PROGRAM WHICH IS ISSUED THROUGH A BANK. THE SUCCESSFUL VENDOR MUST ACCEPT THE STATE OF WEST VIRGINIA VISA PURCHASING CARD FOR PAYMENT OF ALL ORDERS PLACED BY ANY STATE AGENCY AS A CONDITION OF AWARD.						
BID OPENING DATE AND TIME REMAINS 12/27/07 @1:30 P.M.						
NO OTHER CHANGES.						
0001	1	EA		760-75	\$ 29,654.00	\$ 29,654.00
				DOUBLE DRUM VIBRATORY ROLLER/COMPACTOR	Terex TV-1200	
***** THIS IS THE END OF RFQ 708EC008 *****						TOTAL: \$ 29,654.00

SEE REVERSE SIDE FOR TERMS AND CONDITIONS

SIGNATURE <i>Joseph M. Oswald</i>	TELEPHONE 304-623-5670	DATE 12/23/07
TITLE Territory Mgr.	FEIN 55-0219530	ADDRESS CHANGES TO BE NOTED ABOVE

WHEN RESPONDING TO RFQ, INSERT NAME AND ADDRESS IN SPACE ABOVE LABELED 'VENDOR'

**GENERAL TERMS & CONDITIONS
REQUEST FOR QUOTATION (RFQ) AND REQUEST FOR PROPOSAL (RFP)**

1. Awards will be made in the best interest of the State of West Virginia.
2. The State may accept or reject in part, or in whole, any bid.
3. All quotations are governed by the *West Virginia Code* and the *Legislative Rules* of the Purchasing Division.
4. Prior to any award, the apparent successful vendor must be properly registered with the Purchasing Division and have paid the required \$125.00 registration fee.
5. All services performed or goods delivered under State Purchase Orders/Contracts are to be continued for the term of the Purchase Order/Contract, contingent upon funds being appropriated by the Legislature or otherwise being made available. In the event funds are not appropriated or otherwise available for these services or goods, this Purchase Order/Contract becomes void and of no effect after June 30.
6. Payment may only be made after the delivery and acceptance of goods or services.
7. Interest may be paid for late payment in accordance with the *West Virginia Code*.
8. Vendor preference will be granted upon written request in accordance with the *West Virginia Code*.
9. The State of West Virginia is exempt from federal and state taxes and will not pay or reimburse such taxes.
10. The Director of Purchasing may cancel any Purchase Order/Contract upon 30 days written notice to the seller.
11. The laws of the State of West Virginia and the *Legislative Rules* of the Purchasing Division shall govern all rights and duties under the Contract, including without limitation the validity of this Purchase Order/Contract.
12. Any reference to automatic renewal is hereby deleted. The Contract may be renewed only upon mutual written agreement of the parties.
13. **BANKRUPTCY:** In the event the vendor/contractor files for bankruptcy protection, this Contract may be deemed null and void, and terminated without further order.
14. **HIPAA Business Associate Addendum -** The West Virginia State Government HIPAA Business Associate Addendum (BAA), approved by the Attorney General, and available online at the Purchasing Division's web site (<http://www.state.wv.us/admin/purchase/vrc/hipaa.htm>) is hereby made part of the agreement. Provided that, the Agency meets the definition of a Covered Entity (45 CFR §160.103) and will be disclosing Protected Health Information (45 CFR §160.103) to the vendor.

INSTRUCTIONS TO BIDDERS

1. Use the quotation forms provided by the Purchasing Division.
2. **SPECIFICATIONS:** Items offered must be in compliance with the specifications. Any deviation from the specifications must be clearly indicated by the bidder. Alternates offered by the bidder as **EQUAL** to the specifications must be clearly defined. A bidder offering an alternate should attach complete specifications and literature to the bid. The Purchasing Division may waive minor deviations to specifications.
3. Complete all sections of the quotation form.
4. Unit prices shall prevail in cases of discrepancy.
5. All quotations are considered F.O.B. destination unless alternate shipping terms are clearly identified in the quotation.
6. **BID SUBMISSION:** All quotations must be delivered by the bidder to the office listed below prior to the date and time of the bid opening. Failure of the bidder to deliver the quotations on time will result in bid disqualifications.

SIGNED BID TO:

Department of Administration
Purchasing Division
2019 Washington Street East
Post Office Box 50130
Charleston, WV 25305-0130

SIGN IN SHEET

RFQ # 708EC008Date: 12/27/2007

Firm & Representative Name:

Mailing Address:

Phone, Fax, & E-Mail:

1. Anderson Equipment P.O. Box 3109 P (304) 756-2800
Teri Surface Chas, WV 25331 F (304) 756-2799

E-mail tsurface@andersonequip.com

2. Brian Cantrell 7 Ruskin Dr. P 304-366-3075
Anderson Equipment Farmington, WV 26554 F 304-366-7214

E-mail bcantrell@andersonequip.com

3. GARY GRADY P.O. Box 473 P 346-5301
WV TRACTOR CHARLESTON WV F 346-5305

E-mail 25322 wvtractor@msn.com

4. Joe Dinaldo Rt 2 Box 924 P 304-641-2011
Logan Corporation Clarksburg, WV 26301 F 304-623-5676

E-mail jdinaldo@logancorp.com

5. TONY JONES 126 LAKEVIEW DR P 304-741-3569
MH EQUIPMENT CHARLESTON WV 25313 F 304 776-6966

E-mail TJONES@MHEQUIPMENT.C

Karen Cochran
Dan Weese

Please print or write legibly!

Your fax # is essential to contact you timely!