



State of West Virginia
 Department of Administration
 Purchasing Division
 2019 Washington Street East
 Post Office Box 50130
 Charleston, WV 25305-0130

Request for Quotation

RFQ NUMBER
708EC004

PAGE
1

ADDRESS CORRESPONDENCE TO ATTENTION OF
**JOHN JOHNSTON
 304-558-2402**

RFQ COPY

TYPE NAME/ADDRESS HERE

Middletown Tractor Sales
 2032 Fairmont Ave.
 Fairmont, WV 26554

**DIVISION OF HIGHWAYS
 EQUIPMENT DIVISION
 ROUTE 33
 BRUSHY FORK ROAD
 BUCKHANNON, WV
 26201 304-472-1750**

V
E
N
D
O
R

S
H
I
P
T
O

DATE PRINTED	TERMS OF SALE	SHIP VIA	FOB	FREIGHT TERMS
09/24/2007	NET30	Truck	Destination	Prepaid
BID OPENING DATE: 11/13/2007		BID OPENING TIME 01:30PM		

LINE	QUANTITY	UOP	CAT NO	ITEM NUMBER	UNIT PRICE	AMOUNT
001	1	EA		765-66	See page 22 for pricing	
<p>FIVE CUBIC YARD STAINLESS STEEL (HYDRAULIC) SPREADER Monroe Snow and Ice Control Model MSV-108-84-50/304-VA OPEN END CONTRACT</p> <p>TO PROVIDE 5 CUBIC YARD STAINLESS STEEL DEMOUNTABLE ABRASIVE AND CHEMICAL SPREADER (HYDRAULIC) AS DESCRIBED IN THE ATTACHED SPECIFICATIONS 012-1-Z.</p> <p>THERE WILL BE A MANDATORY PRE-BID CONFERENCE AT THE STATE CAPITOL COMPLEX, BUILDING 15, CONFERENCE ROOM, AT 10:00 AM ON 10/26/2007. FAILURE TO ATTEND THE PRE-BID CONFERENCE WILL RESULT IN BID DISQUALIFICATION</p> <p>QUESTIONS: WRITTEN QUESTIONS WILL BE ACCEPTED THROUGH CLOSE OF BUSINESS (5:00 PM EST) ON TUESDAY, 10/16/07. SEND YOUR QUESTIONS TO: PURCHASING DIVISION ATTENTION MICHAEL AUSTIN 2019 WASHINGTON ST. E. CHARLESTON, WV. 25305</p> <p>QUESTIONS MAY BE SENT VIA FAX, E-MAIL, OR REGULAR MAIL. E-MAIL: MAUSTIN@WVADMIN.GOV FAX: 304-558-4115</p> <p>IT IS THE VENDORS RESPONSIBILITY TO VERIFY THAT THEIR QUESTIONS HAVE BEEN RECEIVED BY CALLING 304-558-2316.</p> <p>EXHIBIT 2</p> <p>LIFE OF CONTRACT: THIS CONTRACT BECOMES EFFECTIVE ON</p>						

SEE REVERSE SIDE FOR TERMS AND CONDITIONS

SIGNATURE: *James D. Boyers* TELEPHONE: 304-366-4690 DATE: 11-7-2007

TITLE: President FEIN: 550547175 ADDRESS CHANGES TO BE NOTED ABOVE

**GENERAL TERMS & CONDITIONS
REQUEST FOR QUOTATION (RFQ) AND REQUEST FOR PROPOSAL (RFP)**

1. Awards will be made in the best interest of the State of West Virginia
2. The State may accept or reject in part, or in whole, any bid.
3. All quotations are governed by the *West Virginia Code* and the *Legislative Rules* of the Purchasing Division
4. Prior to any award, the apparent successful vendor must be properly registered with the Purchasing Division and have paid the required \$125.00 registration fee.
5. All services performed or goods delivered under State Purchase Orders/Contracts are to be continued for the term of the Purchase Order/Contract, contingent upon funds being appropriated by the Legislature or otherwise being made available. In the event funds are not appropriated or otherwise available for these services or goods, this Purchase Order/Contract becomes void and of no effect after June 30.
6. Payment may only be made after the delivery and acceptance of goods or services.
7. Interest may be paid for late payment in accordance with the *West Virginia Code*.
8. Vendor preference will be granted upon written request in accordance with the *West Virginia Code*.
9. The State of West Virginia is exempt from federal and state taxes and will not pay or reimburse such taxes.
10. The Director of Purchasing may cancel any Purchase Order/Contract upon 30 days written notice to the seller.
11. The laws of the State of West Virginia and the *Legislative Rules* of the Purchasing Division shall govern all rights and duties under the Contract, including without limitation the validity of this Purchase Order/Contract
12. Any reference to automatic renewal is hereby deleted. The Contract may be renewed only upon mutual written agreement of the parties.
13. **BANKRUPTCY:** In the event the vendor/contractor files for bankruptcy protection, this contract is automatically null and void, and is terminated without further order.
14. **HIPAA Business Associate Addendum** - The West Virginia State Government HIPAA Business Associate Addendum (BAA), approved by the Attorney General, and available online at the Purchasing Division's web site (<http://www.state.wv.us/admin/purchase/vrc/hipaa.htm>) is hereby made part of the agreement. Provided that, the Agency meets the definition of a Covered Entity (45 CFR §160.103) and will be disclosing Protected Health Information (45 CFR §160.103) to the vendor

INSTRUCTIONS TO BIDDERS

1. Use the quotation forms provided by the Purchasing Division
2. **SPECIFICATIONS:** Items offered must be in compliance with the specifications. Any deviation from the specifications must be clearly indicated by the bidder. Alternates offered by the bidder as **EQUAL** to the specifications must be clearly defined. A bidder offering an alternate should attach complete specifications and literature to the bid. The Purchasing Division may waive minor deviations to specifications
3. Complete all sections of the quotation form.
4. Unit prices shall prevail in cases of discrepancy.
5. All quotations are considered F.O.B. destination unless alternate shipping terms are clearly identified in the quotation.
6. **BID SUBMISSION:** All quotations must be delivered by the bidder to the office listed below prior to the date and time of the bid opening. Failure of the bidder to deliver the quotations on time will result in bid disqualifications.

SIGNED BID TO:

Department of Administration
Purchasing Division
2019 Washington Street East
Post Office Box 50130
Charleston, WV 25305-0130



State of West Virginia
 Department of Administration
 Purchasing Division
 2019 Washington Street East
 Post Office Box 50130
 Charleston, WV 25305-0130

Request for Quotation

RFQ NUMBER
708EC004

PAGE
2

ADDRESS CORRESPONDENCE TO ATTENTION OF
JOHN JOHNSTON
304-558-2402

RFQ COPY

TYPE NAME/ADDRESS HERE

VENDOR

Middletown Tractor Sales
 2032 Fairmont Ave.
 Fairmont, WV 26554

SHIP TO

DIVISION OF HIGHWAYS
 EQUIPMENT DIVISION
 ROUTE 33
 BRUSHY FORK ROAD
 BUCKHANNON, WV
 26201 304-472-1750

DATE PRINTED	TERMS OF SALE	SHIP VIA	F.O.B	FREIGHT TERMS
09/24/2007	Net30	truck	Destination	Prepaid

BID OPENING DATE: **11/13/2007** BID OPENING TIME **01:30PM**

LINE	QUANTITY	UOP	CAT NO	ITEM NUMBER	UNIT PRICE	AMOUNT
<p>..... AND EXTENDS FOR A PERIOD OF ONE (1) YEAR OR UNTIL SUCH "REASONABLE TIME" THEREAFTER AS IS NECESSARY TO OBTAIN A NEW CONTRACT OR RENEW THE ORIGINAL CONTRACT. THE "REASONABLE TIME" PERIOD SHALL NOT EXCEED TWELVE (12) MONTHS. DURING THIS "REASONABLE TIME" THE VENDOR MAY TERMINATE THIS CONTRACT FOR ANY REASON UPON GIVING THE DIRECTOR OF PURCHASING THIRTY (30) DAYS WRITTEN NOTICE.</p> <p>UNLESS SPECIFIC PROVISIONS ARE STIPULATED IN THIS CONTRACT DOCUMENT, THE TERMS, CONDITIONS, AND PRICING SET HEREIN ARE FIRM FOR THE LIFE OF THE CONTRACT.</p> <p>RENEWAL: THIS CONTRACT MAY BE RENEWED UPON THE MUTUAL WRITTEN CONSENT OF THE SPENDING UNIT AND VENDOR, SUBMITTED TO THE DIRECTOR OF PURCHASING THIRTY (30) DAYS PRIOR TO THE EXPIRATION DATE. SUCH RENEWAL SHALL BE IN ACCORDANCE WITH THE TERMS AND CONDITIONS OF THE ORIGINAL CONTRACT AND SHALL BE LIMITED TO TWO (2) ONE (1) YEAR PERIODS.</p> <p>CANCELLATION: THE DIRECTOR OF PURCHASING RESERVES THE RIGHT TO CANCEL THIS CONTRACT IMMEDIATELY UPON WRITTEN NOTICE TO THE VENDOR IF THE COMMODITIES AND/OR SERVICE SUPPLIED ARE OF AN INFERIOR QUALITY OR DO NOT CONFORM WITH THE SPECIFICATIONS OF THE BID AND CONTRACT HEREIN.</p> <p>OPEN MARKET CLAUSE: THE DIRECTOR OF PURCHASING MAY AUTHORIZE A SPENDING UNIT TO PURCHASE ON THE OPEN MARKET, WITHOUT THE FILING OF A REQUISITION OR COST ESTIMATE, ITEMS SPECIFIED ON THIS CONTRACT FOR IMMEDIATE DELIVERY IN EMERGENCIES DUE TO UNFORESEEN CAUSES (INCLUDING BUT NOT LIMITED TO DELAYS IN TRANSPORTATION OR AN UNANTICIPATED INCREASE IN THE VOLUME OF WORK).</p> <p>QUANTITIES: QUANTITIES LISTED IN THE REQUISITION ARE</p>						

SEE REVERSE SIDE FOR TERMS AND CONDITIONS

SIGNATURE	TELEPHONE	DATE
President	304-366-4690	11-7-2007
FEIN	ADDRESS CHANGES TO BE NOTED ABOVE	
550547175		



State of West Virginia
 Department of Administration
 Purchasing Division
 2019 Washington Street East
 Post Office Box 50130
 Charleston, WV 25305-0130

Request for Quotation

RFQ NUMBER
708EC004

PAGE
3

ADDRESS CORRESPONDENCE TO ATTENTION OF
JOHN JOHNSTON
304-558-2402

RFQ COPY

TYPE NAME/ADDRESS HERE

Middletown Tractor Sales
 2032 Fairmont Ave.
 Fairmont, WV 26554

VENDOR

SHIP TO

DIVISION OF HIGHWAYS
 EQUIPMENT DIVISION
 ROUTE 33
 BRUSHY FORK ROAD
 BUCKHANNON, WV
 26201
 304-472-1750

DATE PRINTED	TERMS OF SALE	SHIP VIA	F.O.B.	FREIGHT TERMS
09/24/2007	NET30	Truck	Destination	Prepaid

BID OPENING DATE: **11/13/2007** BID OPENING TIME **01:30PM**

LINE	QUANTITY	UOP	CAT NO	ITEM NUMBER	UNIT PRICE	AMOUNT
<p>APPROXIMATIONS ONLY, BASED ON ESTIMATES SUPPLIES BY THE STATE SPENDING UNIT. IT IS UNDERSTOOD AND AGREED THAT THE CONTRACT SHALL COVER THE QUANTITIES ACTUALLY ORDERED FOR DELIVERY DURING THE TERM OF CONTRACT, WHETHER MORE OR LESS THAN THE QUANTITIES SHOWN.</p> <p>ORDERING PROCEDURE: SPENDING UNIT(S) SHALL ISSUE A WRITTEN EQUIPMENT CONTRACT ORDER (FORM NUMBER WV-35) FOR COMMODITIES COVERED BY THIS CONTRACT. THE ORIGINAL WV-35 MUST BE SENT TO THE PURCHASING DIVISION OF THE DEPARTMENT OF ADMINISTRATION. AFTER APPROVAL AND ENCUMBRANCE, ONE COPY OF THE PURCHASE ORDER WILL BE RETURNED TO THE SPENDING UNIT AND ONE COPY FORWARDED TO THE VENDOR AS AUTHORIZATION FOR SHIPMENT. NO ORDER IS VALID UNLESS APPROVED AND ENCUMBERED BY THE PURCHASING DIVISION.</p> <p>BANKRUPTCY: IN THE EVENT THE VENDOR/CONTRACTOR FILES FOR BANKRUPTCY PROTECTION, THIS CONTRACT IS AUTOMATICALLY NULL AND VOID, AND IS TERMINATED WITHOUT FURTHER ORDER.</p> <p>EXHIBIT 6</p> <p>PRICE ADJUSTMENT PROVISION: THE STATE OF WEST VIRGINIA WILL CONSIDER BIDS THAT CONTAIN PROVISIONS FOR PRICE ADJUSTMENTS PRIOR TO THE ORIGINAL EXPIRATION OF THE CONTRACT, PROVIDED THAT SUCH PRICE ADJUSTMENT COVERS BOTH UPWARD AND DOWNWARD MOVEMENT OF THE COMMODITY PRICE, AND THAT ADJUSTMENT IS BASED ON THE "PASS THROUGH" INCREASE OR DECREASE OF RAW MATERIALS AND/OR LABOR, WHICH MAKE UP ALL OR A SUBSTANTIAL PART OF A PRODUCT. ADJUSTMENTS ARE TO BE BASED UPON AN ACTUAL DOLLAR FIGURE, NOT A PERCENTAGE. ALL PRICE ADJUSTMENT REQUESTS MUST BE SUBSTANTIATED IN</p>						

SEE REVERSE SIDE FOR TERMS AND CONDITIONS

SIGNATURE	TELEPHONE	DATE
	304-366-4690	11-7-07

TITLE	FEIN	ADDRESS CHANGES TO BE NOTED ABOVE
President	550547175	

WHEN RESPONDING TO RFQ, INSERT NAME AND ADDRESS IN SPACE ABOVE LABEL FOR VENDOR



State of West Virginia
 Department of Administration
 Purchasing Division
 2019 Washington Street East
 Post Office Box 50130
 Charleston, WV 25305-0130

Request for Quotation

RFO NUMBER
708EC004

PAGE
4

ADDRESS CORRESPONDENCE TO ATTENTION OF
JOHN JOHNSTON
304-558-2402

RFQ COPY

TYPE NAME/ADDRESS HERE

Middletown Tractor Sales
 2032 Fairmont Ave
 Fairmont, WV 26554

DIVISION OF HIGHWAYS
EQUIPMENT DIVISION
ROUTE 33
BRUSHY FORK ROAD
BUCKHANNON, WV
26201 **304-472-1750**

DATE PRINTED	TERMS OF SALE	SHIP VIA	FOB	FREIGHT TERMS
09/24/2007	NET30	Truck	Destination	Prepaid

BID OPENING DATE: **11/13/2007** **BID OPENING TIME 01:30PM**

LINE	QUANTITY	UOP	CAT NO	ITEM NUMBER	UNIT PRICE	AMOUNT
<p>A MANNER ACCEPTABLE TO THE DIRECTOR PURCHASING, E.G. GOVERNMENTAL BENCH MARKS, GENERAL MARKET INCREASE, PUBLISHED PRICE LISTS. SUCH REQUESTS FOR AND INCREASE SHOULD BE RECEIVED IN WRITING BY THE DIRECTOR OF PURCHASING AT LEAST 30 DAYS IN ADVANCE OF THE EFFECTIVE DATE OF THE INCREASE. ANY TIME THE VENDOR REQUESTS A PRICE ADJUSTMENT, THE PURCHASING DIVISION MAY EITHER ACCEPT THE PRICE ADJUSTMENT AND AMEND THE CONTRACT ACCORDINGLY OR REJECT THE ADJUSTMENT IN ITS ENTIRETY AND CANCEL THE CONTRACT.</p> <p>EXHIBIT 4</p> <p>LOCAL GOVERNMENT BODIES: UNLESS THE VENDOR INDICATES IN THE BID HIS REFUSAL TO EXTEND THE PRICES, TERMS, AND CONDITIONS OF THE BID TO COUNTY, SCHOOL, MUNICIPAL AND OTHER LOCAL GOVERNMENT BODIES, THE BID SHALL EXTEND TO POLITICAL SUBDIVISIONS OF THE STATE OF WEST VIRGINIA. IF THE VENDOR DOES NOT WISH TO EXTEND THE PRICES, TERMS, AND CONDITIONS OF THE BID TO ALL POLITICAL SUBDIVISIONS OF THE STATE, THE VENDOR MUST CLEARLY INDICATE SUCH REFUSAL IN HIS BID. SUCH REFUSAL SHALL NOT PREJUDICE THE AWARD OF THIS CONTRACT IN ANY MANNER.</p> <p>REV. 3/88</p> <p>VENDOR PREFERENCE CERTIFICATE</p> <p>CERTIFICATION AND APPLICATION* IS HEREBY MADE FOR PREFERENCE IN ACCORDANCE WITH WEST VIRGINIA CODE, 5A-3-37 (DOES NOT APPLY TO CONSTRUCTION CONTRACTS).</p> <p>A. APPLICATION IS MADE FOR 2.5% PREFERENCE FOR THE</p>						

SEE REVERSE SIDE FOR TERMS AND CONDITIONS

SIGNATURE _____ TELEPHONE **304-366-4690** DATE **11-7-2007**

FILE **President** FEIN **550547175** ADDRESS CHANGES TO BE NOTED ABOVE

WHEN RESPONDING TO RFQ, INSERT NAME AND ADDRESS IN SPACE ABOVE LABELLED VENDOR



State of West Virginia
 Department of Administration
 Purchasing Division
 2019 Washington Street East
 Post Office Box 50130
 Charleston, WV 25305-0130

Request for Quotation

RFQ NUMBER
708EC004

PAGE
5

ADDRESS CORRESPONDENCE TO ATTENTION OF
JOHN JOHNSTON
304-558-2402

RFQ COPY

TYPE NAME/ADDRESS HERE

Middletown Tractor Sales
 2032 Fairmont Ave.
 Fairmont, WV 26554

DIVISION OF HIGHWAYS
EQUIPMENT DIVISION
ROUTE 33
BRUSHY FORK ROAD
BUCKHANNON, WV
26201 **304-472-1750**

DATE PRINTED	TERMS OF SALE	SHIP VIA	FOB	FREIGHT TERMS
09/24/2007	NET30	Truck	Destination	Prepaid

BID OPENING DATE: **11/13/2007** **BID OPENING TIME 01:30PM**

LINE	QUANTITY	UOP	CAT NO	ITEM NUMBER	UNIT PRICE	AMOUNT
<p>REASON CHECKED:</p> <p>() BIDDER IS AN INDIVIDUAL RESIDENT VENDOR AND HAS RESIDED CONTINUOUSLY IN WEST VIRGINIA FOR FOUR (4) YEARS IMMEDIATELY PRECEDING THE DATE OF THIS CERTIFICATION; OR</p> <p>(X) BIDDER IS A PARTNERSHIP, ASSOCIATION OR CORPORATION RESIDENT VENDOR AND HAS MAINTAINED ITS HEAD-QUARTERS OR PRINCIPAL PLACE OF BUSINESS CONTINUOUSLY IN WEST VIRGINIA FOR FOUR (4) YEARS IMMEDIATELY PRECEDING THE DATE OF THIS CERTIFICATION; OR 80% OF THE OWNERSHIP INTEREST OF BIDDER IS HELD BY ANOTHER INDIVIDUAL, PARTNERSHIP, ASSOCIATION OR CORPORATION RESIDENT VENDOR WHO HAS MAINTAINED ITS HEADQUARTERS OR PRINCIPAL PLACE OF BUSINESS CONTINUOUSLY IN WEST VIRGINIA FOR FOUR (4) YEARS IMMEDIATELY PRECEDING THE DATE OF THIS CERTIFICATION; OR</p> <p>() BIDDER IS A CORPORATION NONRESIDENT VENDOR WHICH HAS AN AFFILIATE OR SUBSIDIARY WHICH EMPLOYS A MINIMUM OF ONE HUNDRED STATE RESIDENTS AND WHICH HAS MAINTAINED ITS HEADQUARTERS OR PRINCIPAL PLACE OF BUSINESS WITHIN WEST VIRGINIA CONTINUOUSLY FOR THE FOUR (4) YEARS IMMEDIATELY PRECEDING THE DATE OF THIS CERTIFICATION.</p> <p>B. APPLICATION IS MADE FOR 2.5% PREFERENCE FOR THE REASON CHECKED:</p> <p>(X) BIDDER IS A RESIDENT VENDOR WHO CERTIFIES THAT, DURING THE LIFE OF THE CONTRACT, ON AVERAGE AT LEAST 75% OF THE EMPLOYEES WORKING ON THE PROJECT BEING BID ARE RESIDENTS OF WEST VIRGINIA WHO HAVE RESIDED IN THE STATE CONTINUOUSLY FOR THE TWO YEARS IMMEDIATELY PRECEDING SUBMISSION OF THIS BID;</p>						

SEE REVERSE SIDE FOR TERMS AND CONDITIONS

SIGNATURE 	TELEPHONE 304-366-4690	DATE 11-7-2007
FEIN 550547175	ADDRESS CHANGES TO BE NOTED ABOVE	

WHEN RESPONDING TO RFQ, INSERT NAME AND ADDRESS IN SPACE ABOVE LABELLED VENDOR



State of West Virginia
 Department of Administration
 Purchasing Division
 2019 Washington Street East
 Post Office Box 50130
 Charleston, WV 25305-0130

Request for Quotation

RFQ NUMBER
708EC004

PAGE
6

ADDRESS CORRESPONDENCE TO ATTENTION OF
JOHN JOHNSTON
304-558-2402

RFQ COPY

TYPE NAME/ADDRESS HERE

Middletown Tractor Sales
 2032 Fairmont Ave
 Fairmont, WV 26554

DIVISION OF HIGHWAYS
EQUIPMENT DIVISION
ROUTE 33
BRUSHY FORK ROAD
BUCKHANNON, WV
26201 **304-472-1750**

DATE PRINTED	TERMS OF SALE	SHIP VIA	FOB	FREIGHT TERMS
09/24/2007	Net30	Truck	Destination	Prepaid

BID OPENING DATE: **11/13/2007** **BID OPENING TIME 01:30PM**

LINE	QUANTITY	UOP	CAT NO	ITEM NUMBER	UNIT PRICE	AMOUNT
<p>OR () BIDDER IS A NONRESIDENT VENDOR EMPLOYING A MINIMUM OF ONE HUNDRED STATE RESIDENTS OR IS A NONRESIDENT VENDOR WITH AN AFFILIATE OR SUBSIDIARY WHICH MAINTAINS ITS HEADQUARTERS OR PRINCIPAL PLACE OF BUSINESS WITHIN WEST VIRGINIA EMPLOYING A MINIMUM OF ONE HUNDRED STATE RESIDENTS WHO CERTIFIES THAT, DURING THE LIFE OF THE CONTRACT, ON AVERAGE AT LEAST 75% OF THE EMPLOYEES OR BIDDERS' AFFILIATE'S OR SUBSIDIARY'S EMPLOYEES ARE RESIDENTS OF WEST VIRGINIA WHO HAVE RESIDED IN THE STATE CONTINUOUSLY FOR THE TWO YEARS IMMEDIATELY PRECEDING SUBMISSION OF THIS BID.</p> <p>BIDDER UNDERSTANDS IF THE SECRETARY OF TAX & REVENUE DETERMINES THAT A BIDDER RECEIVING PREFERENCE HAS FAILED TO CONTINUE TO MEET THE REQUIREMENTS FOR SUCH PREFERENCE, THE SECRETARY MAY ORDER THE DIRECTOR OF PURCHASING TO: (A) RESCIND THE CONTRACT OR PURCHASE ORDER ISSUED; OR (B) ASSESS A PENALTY AGAINST SUCH BIDDER IN AN AMOUNT NOT TO EXCEED 5% OF THE BID AMOUNT AND THAT SUCH PENALTY WILL BE PAID TO THE CONTRACTING AGENCY OR DEDUCTED FROM ANY UNPAID BALANCE ON THE CONTRACT OR PURCHASE ORDER.</p> <p>BY SUBMISSION OF THIS CERTIFICATE, BIDDER AGREES TO DISCLOSE ANY REASONABLY REQUESTED INFORMATION TO THE PURCHASING DIVISION AND AUTHORIZES THE DEPARTMENT OF TAX AND REVENUE TO DISCLOSE TO THE DIRECTOR OF PURCHASING APPROPRIATE INFORMATION VERIFYING THAT BIDDER HAS PAID THE REQUIRED BUSINESS TAXES, PROVIDED THAT SUCH INFORMATION DOES NOT CONTAIN THE AMOUNTS OF TAXES PAID NOR ANY OTHER INFORMATION DEEMED BY THE TAX COMMISSIONER TO BE CONFIDENTIAL.</p> <p>UNDER PENALTY OF LAW FOR FALSE SWEARING (WEST VIRGINIA CODE 61-5-3), BIDDER HEREBY CERTIFIES THAT THIS</p>						

SEE REVERSE SIDE FOR TERMS AND CONDITIONS

SIGNATURE	TELEPHONE	DATE
President	304-366-4690	11-7-2007
FEIN	ADDRESS CHANGES TO BE NOTED ABOVE	
550547175		

WHEN RESPONDING TO RFQ, INSERT NAME AND ADDRESS IN SPACE ABOVE LABELLED VENDOR



State of West Virginia
 Department of Administration
 Purchasing Division
 2019 Washington Street East
 Post Office Box 50130
 Charleston, WV 25305-0130

Request for Quotation

RFO NUMBER
708EC004

PAGE
7

ADDRESS CORRESPONDENCE TO ATTENTION OF
JOHN JOHNSTON
304-558-2402

RFQ COPY
 TYPE NAME/ADDRESS HERE

VENDOR

Middletown Tractor Sales
 2032 Fairmont Ave
 Fairmont, WV 26554

SHIP TO

DIVISION OF HIGHWAYS
 EQUIPMENT DIVISION
 ROUTE 33
 BRUSHY FORK ROAD
 BUCKHANNON, WV
 26201 304-472-1750

DATE PRINTED	TERMS OF SALE	SHIP VIA	F.O.B.	FREIGHT TERMS
09/24/2007	Net30	Truck	Destination	Prepaid

BID OPENING DATE: **11/13/2007** BID OPENING TIME: **01:30PM**

LINE	QUANTITY	UOP	CAT. NO.	ITEM NUMBER	UNIT PRICE	AMOUNT
------	----------	-----	----------	-------------	------------	--------

CERTIFICATE IS TRUE AND ACCURATE IN ALL RESPECTS; AND THAT IF A CONTRACT IS ISSUED TO BIDDER AND IF ANYTHING CONTAINED WITHIN THIS CERTIFICATE CHANGES DURING THE TERM OF THE CONTRACT, BIDDER WILL NOTIFY THE PURCHASING DIVISION IN WRITING IMMEDIATELY.

BIDDER: Middletown Tractor Sales

DATE: 11-7-2007

SIGNED: 

TITLE: President

* CHECK ANY COMBINATION OF PREFERENCE CONSIDERATION(S) IN EITHER "A" OR "B", OR BOTH "A" AND "B" WHICH YOU ARE ENTITLED TO RECEIVE. YOU MAY REQUEST UP TO THE MAXIMUM 5% PREFERENCE FOR BOTH "A" AND "B". (REV. 12/00)

NOTICE

A SIGNED BID MUST BE SUBMITTED TO:

DEPARTMENT OF ADMINISTRATION
 PURCHASING DIVISION
 BUILDING 15
 2019 WASHINGTON STREET, EAST
 CHARLESTON, WV 25305-0130

THE BID SHOULD CONTAIN THIS INFORMATION ON THE FACE OF

SEE REVERSE SIDE FOR TERMS AND CONDITIONS

SIGNATURE  TELEPHONE 304-366-4690 DATE 11-7-2007

FLE President FEIN 550547175 ADDRESS CHANGES TO BE NOTED ABOVE

WHEN RESPONDING TO RFQ, INSERT NAME AND ADDRESS IN SPACE ABOVE LABELED "VENDOR"



State of West Virginia
 Department of Administration
 Purchasing Division
 2019 Washington Street East
 Post Office Box 50130
 Charleston, WV 25305-0130

Request for Quotation

RFQ NUMBER
708EC004

PAGE
8

ADDRESS CORRESPONDENCE TO ATTENTION OF
JOHN JOHNSTON
304-558-2402

RFQ COPY
TYPE NAME/ADDRESS HERE
 Middletown Tractor Sales
 2032 Fairmont Ave
 Fairmont, WV 26554

DIVISION OF HIGHWAYS
EQUIPMENT DIVISION
ROUTE 33
BRUSHY FORK ROAD
BUCKHANNON, WV
26201 **304-472-1750**

DATE PRINTED	TERMS OF SALE	SHIP VIA	FOB	FREIGHT TERMS
09/24/2007	Net30	Truck	Destination	Prepaid
BID OPENING DATE: 11/13/2007		BID OPENING TIME 01:30PM		

LINE	QUANTITY	UOP	CAT. NO.	ITEM NUMBER	UNIT PRICE	AMOUNT
<p>THE ENVELOPE OR THE BID MAY NOT BE CONSIDERED: SEALED BID</p> <p>BUYER: 33</p> <p>RFQ. NO.: 708EC004</p> <p>BID OPENING DATE: 11/13/2007</p> <p>BID OPENING TIME: 1:30 PM</p> <p>PLEASE PROVIDE A FAX NUMBER IN CASE IT IS NECESSARY TO CONTACT YOU REGARDING YOUR BID: ----- 304-366-4698 -----</p> <p>CONTACT PERSON (PLEASE PRINT CLEARLY): ----- Zach Marsh -----</p> <p>See page 22 for pricing</p> <p>***** THIS IS THE END OF RFQ 708EC004 ***** TOTAL: _____</p>						

SEE REVERSE SIDE FOR TERMS AND CONDITIONS

SIGNATURE	TELEPHONE	DATE
<i>[Signature]</i>	304-366-4690	11-7-2007
FILE	FEIN	ADDRESS CHANGES TO BE NOTED ABOVE
President	550547175	

WHEN RESPONDING TO REQ. INSERT NAME AND ADDRESS IN SPACE ABOVE LABELLED VENDOR

WEST VIRGINIA DEPARTMENT OF TRANSPORTATION
DIVISION OF HIGHWAYS
EQUIPMENT DIVISION

21

NOTE: Vendor should type
Bidder's Evaluation
Report.

BIDDER'S EVALUATION REPORT

PROCUREMENT SPECIFICATIONS FOR OPEN END CONTRACT
NO. 012-1-Z

OPEN END CONTRACT
FIVE CUBIC YARD STAINLESS STEEL DEMOUNTABLE ABRASIVE
AND CHEMICAL SPREADER (HYDRAULIC)

NOTE TO BIDDER: Procurement Specification No. 012-1-Z, Paragraph 2.0 recommends the completion and submittal of this Report with your bid. Purpose of this Report is to enable the West Virginia Division of Highways Evaluation Committee to make full and fair evaluation of the bid. Addendums in order, along with exception sheets, should be with Bidder's Evaluation Report.
FAILURE TO SUBMIT THIS REPORT, COMPLETE IN ITS ENTIRETY, MAY SUBJECT THE BIDDER TO DISQUALIFICATION.

Reference Requisition No.: 708EC004

Bidder's Name: Middletown Tractor Sales

Address: 2032 Fairmont Ave Fairmont, WV 26554

Telephone Number: 304-366-4690

Years Bidder has been registered to do business with the State of West Virginia: 35 YRS.

Years Company has been an authorized dealer for proposed unit: 1 YRS.

X3.2 Have you complied with all mandatory specifications? YES NO

X4.2 DELIVERY:

X4.2.1 Delivery date of completed representative unit: 45 Calendar Days After Date of
Purchase Agreement

X4.2.2 Delivery date of balance of completed units: 135 Calendar Days After Date of
Purchase Agreement

X5.0 AWARD CRITERIA;

X5.1 Prices for units in quantities of

1-10	\$9744.00	per unit
11-20	\$10,544.00	per unit
21-30	\$10,544.00	per unit
31-40	\$10,544.00	per unit
41-50	\$10,544.00	per unit
51 and over	\$10,544.00	per unit

X6.0 SPECIFICATIONS - GENERAL

X6.1 Manufacturer, model, series, and date of manufacture of proposed unit:

Monroe Snow and Ice Control MSV-108-84-50/304-VA Model year 2007 or newer

Is descriptive literature, fully describing proposed unit attached to your bid? YES NO

If not, why? N/A

X6.2 Will the required number of service manuals, and complete parts list be delivered to the Equipment Division at Buckhannon upon completion of delivery of total units?

YES NO

Will the required Equipment Preventive Maintenance Form (Section X6.2 of Bidders Evaluation Report) be provided upon inspection of the pilot unit?

YES NO

EQUIPMENT PREVENTATIVE MAINTENANCE QUESTIONNAIRE

THIS FORM MUST BE COMPLETED IN ITS ENTIRETY BY SUCCESSFUL BIDDER OR MANUFACTURER=S TECHNICAL REPRESENTATIVE PRIOR TO DELIVERY OF PILOT MODEL TO THE WVDOT.

DESCRIPTION: _____ MAKE: _____

MODEL: _____ YEAR: _____ PURCHASE AMOUNT: _____

ENGINE: MAKE: _____ MODEL: _____ FUEL TYPE: _____

HORSEPOWER: _____ CYLINDER: _____ ENGINE SERIAL: _____

COOLING SYSTEM CAPACITY: _____

BELTS: DESCRIPTION: _____ PART NUMBERS: _____

GVW: _____ AXLE CAPACITY:FRONT: _____ REAR: _____

TIRES: FRONT MAKE & SIZE: _____

REAR MAKE & SIZE: _____

DIMENSIONS OF UNIT: LENGTH: _____ WIDTH: _____ LENGTH: _____

VENDOR CONTACT PERSON: _____ PHONE: _____

PARTS:

BATTERY MAKE: _____ MODEL: _____ CCA: _____

TOP OR SIDE POST: _____ DIMENSIONS: LENGTH _____ WIDTH _____ HEIGHT _____

SPARK PLUGS OR FUEL INJECTORS MAKE: _____ PART # _____

FUEL PUMP OR INJECTION PUMP MAKE: _____ MODEL: _____

ALTERNATOR MAKE: _____ PART #: _____

STARTER MAKE: _____ PART #: _____

TURBO CHARGER MAKE: _____ PART #: _____

TRANS. MAKE: _____ MODEL: _____ AUTO/MANUAL: _____

HYDRAULIC PUMP MAKE: _____ MODEL: _____

FILTERS	MAKE	PART NO.	LUBRICANT	MANUFACTURER TYPE
OIL	_____	_____	ENGINE	_____
AIR INNER	_____	_____	TRANSMISSION	_____
AIR OUTER	_____	_____	POWER STEERING	_____
FUEL PRIMARY	_____	_____	HYDRAULIC	_____
FUEL SECONDARY	_____	_____	DIFFERENTIALS	_____
COOLANT	_____	_____	BRAKE FLUID	_____
HYDRAULIC	_____	_____	COOLANT	_____
OTHER	_____	_____	OTHER	_____

X6.3 TRAINING:

Will training seminar be conducted on Preventive Maintenance, Operator and Mechanic Training
 YES NO

Will you conduct training with each purchase order against this open end contract?
 YES NO

Will training be conducted within 2 working days from the delivery of the pilot unit on the individual purchase order?
 YES NO

If NO, explain time frame N/A

Will an Operator's Manual be furnished directly to Letha Lamb, Training Academy prior to the delivery of the pilot?
 YES NO

X6.4 If you are the successful vendor, will you furnish all training aids, i.e., videos, projectors, required in conducting the training?
 YES NO

X6.4.1 Will all manuals, booklets, etc. explaining preventive maintenance, operator procedures, and service schedule be delivered with each unit?
 YES NO
If NO, explain N/A

X6.5 WARRANTY AND SERVICE POLICY

Will the warranty and service you provide comply with all areas as stated in Section 6.5 of specifications
 YES NO

Is warranty literature attached?
 YES NO

Is a minimum two (2) year bumper to bumper basic parts and labor warranty included?
 YES NO

Describe:

See attached Warranty Statement

X6.5 WARRANTY AND SERVICE POLICY QUESTIONNAIRE

THIS FORM MUST BE COMPLETED IN ITS ENTIRETY BY THE SUCCESSFUL BIDDER OR MANUFACTURERS TECHNICAL REPRESENTATIVE PRIOR TO DELIVERY OF PILOT MODEL TO THE WVDOH (If additional lines are needed, make copies of form.)

1. Define the terms of the standard warranty. If not offered, so state. (Attach copy)

2. Define warranty service to be performed at DOH facilities and warranty service to be performed at manufacturer's representative facility. List name and location of manufacturer's representative.

3. List locations for parts inventories that are within the State of West Virginia. Also, list availability levels, if known.

4. During the term of warranty, list the guarantee discount to manufacturer's published list price for parts that bidder will sell the parts to owner.

- A. Terms: Net 30 Manufacturer's published list price less: _____ % discount
- B. Terms: Net 60 Manufacturer's published list price less: _____ % discount
- C. Terms: Net 90 Manufacturer's published list price less: _____ % discount

5. During the term of warranty, will all manufacturers or engineering improvements be submitted to Division of Highways? ___ YES ___ NO

6. During the term of warranty, list the guaranteed rates charged for repair to the unit.

- A. Shop Rate \$ _____ per mechanic hour
- B. Travel Time Charge \$ _____ per mechanic hour
(Specify if one-way) _____ ; port to port _____
- C. Mileage Charge \$ _____ per vehicle mile
(Specify if one-way) _____ ; port to port _____
- D. Field Mechanic Rate \$ _____ per mechanic hour
- E. Specify period of time that prices are in effect: _____
- F. Surcharge for miscellaneous items: _____ %

X6.6 EVALUATION COMMITTEE REQUIREMENTS

Is all component specifications, product literature, component models provided for Evaluation Committee bid determination? YES NO

X6.7 Will all parts, equipment, accessories, material, design and performance characteristics not specified herein, but which are necessary to provide a complete unit, be furnished with the unit and conform in strength, quality of material, and quality of workmanship to those which are advertised and provided to the market in general by the unit industry?

YES NO

X6.7.1 Are all parts and accessories adequate and regularly supplied as standard to be included except those which may be duplications of specifications herein, and except these by specification are not to be furnished?

YES NO

X6.7.2 Are all standard safety features that are required by Federal and State statutes of law included?

YES NO

X7.0 SPECIFICATIONS OF THE QUOTED UNIT

The bidder should complete the following schedule in order for the Division of Highways to compare the actual bid unit to the specifications. Should the bidder except a requirement, then such exception may be only on the basis that such feature is not offered by the manufacturer. The Division will have the sole discretion as to whether the bidder's substitution meets the requirements of the specifications.

Manufacturer: Monroe Snow and Ice Control

Model: MSV-108-84-50/304-VA

X7.1 Is spreaders offered the commercial heavy duty, self contained, hopper type? YES NO

X7.2 Does spreader consist of a 12 gauge 304 stainless steel body, feeder conveyor, spinner disc, power drive, and all components necessary to make a complete operating unit? YES NO

X7.3 Is the unit capable of uniformly spreading sand, cinders, salt, calcium chloride, or other mixtures up to a width of forty (40) feet? YES NO

X7.4 Body:

X7.4.1 Is the body of 304 stainless steel construction 100% welded inside and outside of the body?

YES NO

X7.4.2 Capacity struck: 5 CUBIC YARDS

X7.4.3 Inside length: 9 FEET as measured from front of spreader hopper to the rear hopper gate and conveyor chain exit point

X7.4.4 Overall height: 50 INCHES

- X7.4.5** Inside width: 84 INCHES 27
- X7.4.6** Are the body sides sloped approximately 45° pitch to insure free flow of materials to the conveyor X YES NO
- X7.4.7** Gauge of 304 stainless steel in sides and endgates is 12 Gauge.
- X7.4.8** Is a formed double crimped section on top of body for additional support? X YES NO
- X7.4.9** Sills constructed of 10 gauge 304 stainless steel.
Supported on rectangular formed cross sills X YES NO
- X7.4.10** Number of 12 gauge full slope body side supports tying the cross sills with body sides? 4 each side
- X7.4.11** Are four (4) 304 stainless steel 5/8 inch round lifting eyes fitted to spreader; inside eye opening designed to allow the passage of an alloy eye grade 80 3/8 inch grab hook with a width dimension of 2 11/16 inch (with top screen down in the rest position on top of spreader X YES NO
two (2) on each side of spreader mounted and secured in such a manner that the entire unit may be safely lifted for storage/installing purposes X YES NO
- X7.4.12** Is all necessary hardware stainless steel X YES NO
- X7.4.13** Is a 12 gauge 304 stainless steel front mounted spill shield provided? X YES NO
Is the spill shield 76 inches wide x 20 inches long and sloped front to rear, in order that loaded material, salt, cinders, etc. will fall into hopper as spreader unloads? X YES NO
- X7.4.13.1** Is a 300 series stainless steel grab handle mounted to the drivers side spill shield side plate at a convenient location to assist operator when climbing atop spreader to remove "chunks or debris"? X YES NO
- X7.4.14** Will a fold up stainless steel ladder be mounted on the rear of spreader body at right for easier access to top? X YES NO
Does the ladder have hand holds, non-slip strut steps, and manufacturers locking mechanism to lock ladder in up position when not in use? X YES NO
- X7.4.14.1** Is a 300 series stainless steel grip strut step plate mounted on rear of spreader "spinner" housing frame, above rear baffle, full width of spinner housing? X YES NO
- X7.4.15** Is a work light mounted on cab shield for night shift visibility of spreader grating with weatherproof wiring? X YES NO
- X7.5** Conveyor:
- X7.5.1** Is the conveyor located in bottom of hopper and capable of engaging material along its full length and moving material to rear adjustable metering gate? X YES NO

- X7.5.2 Is conveyor continuous ladder type consisting of two parallel chains with cross bars on 4 2" centers made of 1/4" x 1-1/2" steel? YES NO
- X7.5.3 Is each cross bar formed and welded both top and bottom to chain links YES NO
- X7.5.4 Tensile strength of each chain: See Addendum pounds
- X7.5.5 Overall width of chain conveyor: 22 inches
- X7.5.6 Are replaceable rubber wear strips provided to prevent contact of material being spread with the chain? YES NO
- X7.5.7 Is a 10 gauge 304 stainless steel heavy-duty replaceable conveyor plate at least 3/16" thick fitted? YES NO
- X7.5.8 Is the chain drive through 1-1/2" sprockets and shafting front and rear? YES NO
- X7.5.9 Does conveyor have adjustment provisions at rear of spreader for at least 3" lateral takeup? YES NO
- X7.5.10 Is additional 7 gauge 304 stainless steel reinforcing plate welded to longitudinal webs covering the area of the drive shaft, bearing, and idler bearing provided? See Addendum YES NO
- X7.5.11 Is material composition of adjustment mechanism rust proof? YES NO
- X7.5.12 Is conveyor drive motor mounted on hopper side of reduction gear box? YES NO
- X7.5.12.1 Does the reduction gear box provide a 50:1 ratio? YES NO
- X7.5.13 Does conveyor gear box have its drive shaft extended through rear of gear housing? See Addendum YES NO
- Is the shaft end machined to accommodate the application rate sensor shaft for the Dickey-John Automatic Control System, Model ICS-2000? See Addendum YES NO
- Is the necessary oil seal included? See Addendum YES NO
- X7.5.13.1 Is adequate shielding provided that will cover exposed shaft, coupling, and application rate sensor? YES NO
- X7.5.14 Is a 7 gauge stainless steel adjustable greasable screw jack type discharge gate located at the body rear to adjust the flow of material to the spinner? YES NO
- X7.5.15 Feedgate opening: 12 inches high x 18 inches wide
- X7.5.16 Is any and all exposed moving or rotating mass adequately shielded in order to protect personnel while performing required operational adjustments? YES NO

X7.6 Distributor Spinner Assembly:

X7.6.1 Diameter of urethane distributor disc 20 inchesX7.6.1.1 Number of fins: 6X7.6.1.2 Are fins designed to obtain a controlled spread of materials from four feet (4') to forty feet (40')? X YES NOX7.6.2 Is material guided from conveyor end to distributor disc by means of an externally adjustable material flow baffles, enclosed within the chute? X YES NOX7.6.3 Is the spinner vertically adjustable to a full 16 inches? See Addendum YES NOand See Addendum inch spinner position below mounting surface?X7.6.4 Is a deflector baffle or diverter chute provided in an enclosed distributor spinner hopper assembly so it can be positioned in such a manner that material can be unloaded from spreader without striking spinner? X YES NO

X7.7 Baffles:

X7.7.1 Are baffles provided to control direction and width of spread? See Addendum YES NOX7.7.1.2 Are there four (4) sections over right, left, rear and front of spinners? See Addendum YES NOX7.7.2 Are sections easily adjusted from the full down to the horizontal position without use of tools? X YES NO

X7.8. Power Drive:

X7.8.1 Is the power drive hydraulic type? X YES NOX7.8.1.2 Are two (2) hydraulic motors provided - one (1) powering the spinner assembly and one (1) powering the conveyor? X YES NOX7.8.2 Spinner hydraulic motor mounted below the spinner hopper assembly? X YES NOX7.8.3 The conveyor hydraulic motor of the orbital, low speed, hi-torque integrally mounted to conveyor gear box? X YES NO

X7.9 Pintle Conveyor Chain:

X7.9.1 Is the pintle conveyor chain constructed of heat treated formed links with locked, non-turning pins? X YES NOX7.9.2 Specify tensile strength of each conveyor chain strand 21,000 pounds

X7.10 Screen Over Hopper:

X7.10.1 Are four (4) sectional screens hinged to 10 gauge 304 stainless steel 4 inch x 6 inch formed box beam running longitudinally the full length of spreader hopper? X YES NOIf not specify: N/A

X7.10.2 Do screen sections have 3/8" diameter rods welded to 3/16" - 2:" angle frame forming 2-1/2" x 2-1/2" square openings? YES NO

If not specify: n/a

X7.10.3 Do screens increase overall height of spreader more than 7 inches down the center? YES NO

X7.11 Is lighting in accordance with the attached sketch? See Addendum YES NO

X7.11.1 Is the combination and marker lights LED type YES NO

X7.11.2 Stop, tail, turn combination lights and marker lights are shielded YES NO

X7.11.3 Strobe light is "quad flash" YES NO

X7.12 Hydraulic Components:

X7.12.1 Are all necessary fittings for complete hookup of spreader hydraulics to DOH dump trucks central hydraulic system provided? YES NO

X7.12.2 Are all fittings of the steel type and designed for hydraulic use? YES NO

X7.12.3 Will the hoses mate with the quick disconnects on the central hydraulic system of the truck?
See Addendum YES NO

Will you furnish proper mating quick disconnects, metal caps, and plugs for connection to truck manifold? YES NO

X7.13 Is an anodized 6061T6 aluminum grease manifold block mounted at the rear of the body which incorporates the front bearing grease extension tubes, rear bearing grease fittings and feedgate screw jack lubrication tube? See Addendum YES NO

X7.13.1 Are all other fittings placed at convenient locations for normal maintenance? See Addendum YES NO

Number of grease manifold block ports: See Addendum

X7.13.2 Are hoses used in the grease manifold system Parflex hose by Parker Hannifin or equal, with 1/8 inch I.D., 0.34 inch maximum O.D., a maximum working pressure of 2500 psi and a minimum burst pressure of 10,000 psi? YES NO

Are hose assemblies held in place by a sufficient number of rubber cushioned hose clamps? YES NO

X7.14 Is one (1) piece of angle iron 3/8" x 4" X 90" and two (2) pieces of 1" round shafting ten inches (10") long provided but not installed for each unit? YES NO

X7.15 Other standard features:

List other standard features offered but not specifically addressed above:

N/A

X7.16 Paint:

Describe method of painting parts and accessories that are not required to be stainless or rustproof:

Top Screens are Powder Coated

Manufactirers Standard Primer and Paint on Motor and Gearbox

X7.17 Does unit offered meet or exceed "Occupational Safety and Health Act of 1970"?

YES NO

X7.18 Does unit conform to the advertising guidelines?

YES NO

AGREEMENT ADDENDUM

In the event of conflict between this addendum and the agreement, this addendum shall control:

1. **ARBITRATION** - Any references to arbitration contained in the agreement are hereby deleted. Disputes arising out of the agreement shall be presented to the West Virginia Court of Claims.
2. **HOLD HARMLESS** - Any clause requiring the Agency to indemnify or hold harmless any party is hereby deleted in its entirety.
3. **GOVERNING LAW** - The agreement shall be governed by the laws of the State of West Virginia. This provision replaces any references to any other State's governing law.
4. **TAXES** - Provisions in the agreement requiring the Agency to pay taxes are deleted. As a State entity, the Agency is exempt from Federal, State, and local taxes and will not pay taxes for any Vendor including individuals, nor will the Agency file any tax returns or reports on behalf of Vendor or any other party.
5. **PAYMENT** - Any references to prepayment are deleted. Payment will be in arrears.
6. **INTEREST** - Should the agreement include a provision for interest on late payments, the Agency agrees to pay the maximum legal rate under West Virginia law. All other references to interest or late charges are deleted.
7. **RECOUPMENT** - Any language in the agreement waiving the Agency's right to set-off, counterclaim, recoupment, or other defense is hereby deleted.
8. **FISCAL YEAR FUNDING** - Service performed under the agreement may be continued in succeeding fiscal years for the term of the agreement, contingent upon funds being appropriated by the Legislature or otherwise being available for this service. In the event funds are not appropriated or otherwise available for this service, the agreement shall terminate without penalty on June 30. After that date, the agreement becomes of no effect and is null and void. However, the Agency agrees to use its best efforts to have the amounts contemplated under the agreement included in its budget. Non-appropriation or non-funding shall not be considered an event of default.
9. **STATUTE OF LIMITATION** - Any clauses limiting the time in which the Agency may bring suit against the Vendor, lessor, individual, or any other party are deleted.
10. **SIMILAR SERVICES** - Any provisions limiting the Agency's right to obtain similar services or equipment in the event of default or non-funding during the term of the agreement are hereby deleted.
11. **ATTORNEY FEES** - The Agency recognizes an obligation to pay attorney's fees or costs only when assessed by a court of competent jurisdiction. Any other provision is invalid and considered null and void.
12. **ASSIGNMENT** - Notwithstanding any clause to the contrary, the Agency reserves the right to assign the agreement to another State of West Virginia agency, board or commission upon thirty (30) days written notice to the Vendor and Vendor shall obtain the written consent of Agency prior to assigning the agreement.
13. **LIMITATION OF LIABILITY** - The Agency, as a State entity, cannot agree to assume the potential liability of a Vendor. Accordingly, any provision limiting the Vendor's liability for direct damages or limiting the Vendor's liability under a warranty to a certain dollar amount or to the amount of the agreement is hereby deleted. In addition, any limitation is null and void to the extent that it precludes any action for injury to persons or for damages to personal property.
14. **RIGHT TO TERMINATE** - Agency shall have the right to terminate the agreement upon thirty (30) days written notice to Vendor.
15. **TERMINATION CHARGES** - Any provision requiring the Agency to pay a fixed amount or liquidated damages upon termination of the agreement is hereby deleted. The Agency may only agree to reimburse a Vendor for actual costs incurred or losses sustained during the current fiscal year due to wrongful termination by the Agency prior to the end of any current agreement term.
16. **RENEWAL** - Any reference to automatic renewal is hereby deleted. The agreement may be renewed only upon mutual written agreement of the parties.
17. **INSURANCE** - Any provision requiring the Agency to insure equipment or property of any kind and name the Vendor as beneficiary or as an additional insured is hereby deleted.
18. **RIGHT TO NOTICE** - Any provision for repossession of equipment without notice is hereby deleted. However, the Agency does recognize a right of repossession with notice.
19. **ACCELERATION** - Any reference to acceleration of payments in the event of default or non-funding is hereby deleted.
20. **AMENDMENTS** - All amendments, modifications, alterations or changes to the agreement shall be in writing and signed by both parties. No amendment, modification, alteration or change may be made to this addendum without the express written approval of the Purchasing Division and the Attorney General.

ACCEPTED BY:
STATE OF WEST VIRGINIA

Spending Unit: _____

Signed: _____

Title: _____

Date: _____

VENDOR

Company Name: Middletown Tractor Sales

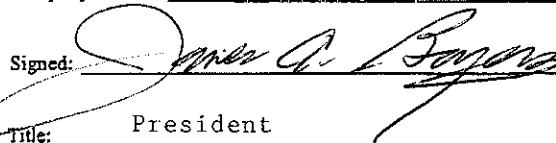
Signed: 

Title: President

Date: 11-7-07

STATE OF WEST VIRGINIA
Purchasing Division

PURCHASING AFFIDAVIT

West Virginia Code §5A-3-10a states: No contract or renewal of any contract may be awarded by the state or any of its political subdivisions to any vendor or prospective vendor when the vendor or prospective vendor or a related party to the vendor or prospective vendor is a debtor and the debt owed is an amount greater than one thousand dollars in the aggregate

DEFINITIONS:

"Debt" means any assessment, premium, penalty, fine, tax or other amount of money owed to the state or any of its political subdivisions because of a judgment, fine, permit violation, license assessment, defaulted workers' compensation premium, penalty or other assessment presently delinquent or due and required to be paid to the state or any of its political subdivisions, including any interest or additional penalties accrued thereon.

"Debtor" means any individual, corporation, partnership, association, limited liability company or any other form or business association owing a debt to the state or any of its political subdivisions. "Political subdivision" means any county commission; municipality; county board of education; any instrumentality established by a county or municipality; any separate corporation or instrumentality established by one or more counties or municipalities, as permitted by law; or any public body charged by law with the performance of a government function or whose jurisdiction is coextensive with one or more counties or municipalities. "Related party" means a party, whether an individual, corporation, partnership, association, limited liability company or any other form or business association or other entity whatsoever, related to any vendor by blood, marriage, ownership or contract through which the party has a relationship of ownership or other interest with the vendor so that the party will actually or by effect receive or control a portion of the benefit, profit or other consideration from performance of a vendor contract with the party receiving an amount that meets or exceed five percent of the total contract amount.

EXCEPTION: The prohibition of this section does not apply where a vendor has contested any tax administered pursuant to chapter eleven of this code, workers' compensation premium, permit fee or environmental fee or assessment and the matter has not become final or where the vendor has entered into a payment plan or agreement and the vendor is not in default of any of the provisions of such plan or agreement.

LICENSING: Vendors must be licensed and in good standing in accordance with any and all state and local laws and requirements by any state or local agency of West Virginia, including, but not limited to, the West Virginia Secretary of State's Office, the West Virginia Tax Department, West Virginia Insurance Commission, or any other state agencies or political subdivision. Furthermore, the vendor must provide all necessary releases to obtain information to enable the Director or spending unit to verify that the vendor is licensed and in good standing with the above entities.

CONFIDENTIALITY: The vendor agrees that he or she will not disclose to anyone, directly or indirectly, any such personally identifiable information or other confidential information gained from the agency, unless the individual who is the subject of the information consents to the disclosure in writing or the disclosure is made pursuant to the agency's policies, procedures and rules. Vendors should visit www.state.wv.us/admin/purchase/privacy for the Notice of Agency Confidentiality Policies.

Under penalty of law for false swearing (West Virginia Code, §61-5-3), it is hereby certified that the vendor acknowledges the information in this said affidavit and are in compliance with the requirements as stated.

Vendor's Name: Middletown Tractor Sales

Authorized Signature:  Date: 11-7-2007



State of West Virginia
 Department of Administration
 Purchasing Division
 2019 Washington Street East
 Post Office Box 50130
 Charleston, WV 25305-0130

Request for Quotation

RFQ NUMBER
708EC004

PAGE
1

ADDRESS CORRESPONDENCE TO ATTENTION OF
MICHAEL AUSTIN 304-558-2402

VENDOR

*709043751 304-366-4690
 MIDDLETOWN TRACTOR SALES
 2032 FAIRMONT AVE
 FAIRMONT WV 26554

SHIP TO

DIVISION OF HIGHWAYS
 EQUIPMENT DIVISION
 ROUTE 33
 BRUSHY FORK ROAD
 BUCKHANNON, WV
 26201 304-472-1750

DATE PRINTED	TERMS OF SALE	SHIP VIA	F.O.B.	FREIGHT TERMS
11/01/2007	NET30	Truck	Destination	Prepaid
BID OPENING DATE: 11/13/2007		BID OPENING TIME 01:30PM		

LINE	QUANTITY	UOP	CAT NO.	ITEM NUMBER	UNIT PRICE	AMOUNT
ADDENDUM NO. 1						
CHANGES TO THE SPECIFICATIONS PER THE ATTACHED.						
BID OPENING DATE AND TIME REMAINS 11/13/07 @1:30 P.M.						
NO OTHER CHANGES.						
0001	1	EA		765-66	See page 22 for pricing	
FIVE CUBIC YARD STAINLESS STEEL (HYDRAULIC) SPREADER						
Monroe Snow and Ice Control Model MSV-108-84-50/304-VA						
***** THIS IS THE END OF RFQ 708EC004 ***** TOTAL:						See page 22 for pricing

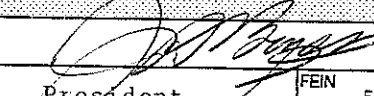
SIGNATURE			SEE REVERSE SIDE FOR TERMS AND CONDITIONS		
 President		TELEPHONE	DATE		
TITLE		550547175	304-366-4690	11-7-2007	
ADDRESS CHANGES TO BE NOTED ABOVE					

WHEN RESPONDING TO RFQ, INSERT NAME AND ADDRESS IN SPACE ABOVE LABELLED 'VENDOR'

ADDENDUM #1

708EC004

OPEN END CONTRACT

5 CUBIC YARD STAINLESS STEEL (HYDRAULIC) SPREADER

CHANGES TO BIDDER'S EVALUATION REPORT:

X7.5.4 NO CHANGE REQUIRED

Tensile strength of each chain: 21,000 pounds

FROM:

X7.5.7 Is a 10 gauge 304 stainless steel heavy duty replaceable conveyor plate at least 3/16" thick fitted? N/A YES NO

TO:

X7.5.7 Is a 10 gauge 304 stainless steel heavy duty replaceable conveyor plate fitted? X YES NO

FROM:

X7.5.10 Is additional 7 gauge 304 stainless steel reinforcing plate welded to longitudinal webs covering the area of the drive shaft, bearing, and idler bearing provided? YES NO N/A

TO:

X7.5.10 Is additional 7 gauge 304 stainless steel reinforcing plate welded to longitudinal webs covering the area of the drive shaft, bearing, and idler bearing provided if required? YES X NO

Not Required
See Attachment Titled
Deviations from Non-mandatory Specifications

FROM:

X7.5.13 Does conveyor gear box have its drive shaft extended through rear of gear housing? N/A YES NO

Is the shaft end machined to accommodate the application rate sensor shaft for the Dickey-John Automatic Control System, Model ICS-2000? YES NO N/A

Is the necessary oil seal included? YES NO N/A

TO:

X7.5.13 Does the conveyor gear box motor have an integral speed sensor X YES NO

Addendum #1
708EC004

FROM:

X7.6.3 Is the spinner vertically adjustable to a full 16 inches? N/A YES ___ NO
And N/A inch spinner position below mounting surface?

TO:

X7.6.3 Spinner is vertically adjustable 18 inches and provides a 20 - 32 inch spinner position below the mounting surface.

FROM:

X7.7.1 Are baffles provided to control direction and width of spread? N/A YES ___ NO

X7.7.1.2 Are there four (4) sections over right, left, rear and front of spinners? N/A YES ___ NO

TO:

X7.7.1 Are baffles provided to control direction and width of spread X YES ___ NO

X7.7.1.2 Are there four (4) sections over right, left, rear and front of spinners
X YES ___ NO

Is front spinner baffle shield (truck side) stationary X YES ___ NO

FROM:

X7.11 Is lighting in accordance with the attached sketch? N/A YES ___ NO

TO:

X7.11 Is lighting in accordance with the attached sketch and wiring schematic?
X YES ___ NO

Addendum #1
708EC004

FROM:

X7.12.3 Will the hoses mate with the quick disconnects on the central hydraulic system of the truck? N/A YES ___ NO
Will you furnish proper mating quick disconnects, metal caps, and plugs for connection to truck manifold? N/A YES ___ NO

TO:

X7.12.3 Will the hoses mate with the quick disconnects on the central hydraulic system of the truck? X YES NO
Will you furnish the male quick disconnects, metal caps, and plugs for connection to truck manifold? X YES NO

FROM:

X7.13 Is an anodized 6061T6 aluminum grease manifold block mounted at the rear of the body which incorporates the front bearing grease extension tubes, rear bearing grease fittings and feedgate screw jack lubrication tube? N/A YES ___ NO

TO:

X7.13 Is an anodized 6061T6 aluminum YES X NO
(OR)
304 stainless steel X YES NO grease manifold block mounted at the rear of the body which incorporates the front bearing grease extension tubes, rear bearing grease fittings and feedgate screw jack lubrication tube? X YES NO

FROM:

X7.13.1 Are all other fittings placed at convenient locations for normal maintenance? N/A YES ___ NO
Number of grease manifold block ports: N/A

TO:

X7.13.1 The anodized 6061T6 aluminum YES X NO
(OR)
304 stainless steel grease manifold block X YES NO has 6 ports tapped to accept three (3) 1/8 inch straight grease zerks and three (3) 1/8 inch grease Parflex hoses to provide for adequate one location greasing of the front and rear bearings and feed gate screw jack X YES NO
Are any unused ports properly plugged X YES NO

Middletown Tractor Sales

2032 Fairmont Avenue, Fairmont, WV 26554
Phone (304) 366-4690 Ext. Fax (304) 366-4698
E-mail: Adam@middletowntractor.com



JOHN DEERE

November 7th 2007

Deviations from Non-Mandatory Specifications

Reference Addendum #1

X.7 5.10 Is additional 7 gauge stainless steel reinforcing plate welded to longitudinal webs covering the area of the driveshaft bearing and idler bearing provided if required? Yes NO

With a 10 gauge long-sill as opposed to a 12 gauge the structural integrity does not require additional 7-gauge steel reinforcing plates



Monroe Brute

Heavy Duty Model MSV V-Box

Standard Specifications:

- ➔ 10 Gauge Hopper Shell with 45° Sloped Sides
- ➔ 7 Gauge Longitudinals
- ➔ 100% Continuously Welded
- ➔ 4-Bolt Flange Relubeable Bearings
- ➔ Front and Rear Wipers
- ➔ Replaceable Chain Shields
- ➔ 3/8" Bar Flights
- ➔ 3/16" Replaceable Floor
- ➔ 50:1 Worm Drive Gear Box
- ➔ 3/8" Rod, Heavy Duty Top Screens
- ➔ 2" Drive Shaft with 2" Spring Loaded Idler Shaft
- ➔ Screw Adjustable Gate Jack
- ➔ 5/8" Rod Lift Loops
- ➔ Slide Gussets on 24" Centers
- ➔ Tip-Up Adjustable Spinner
- ➔ Lower spinner assembly can be rotated 180° to achieve desired spread pattern.
- ➔ Powder Coated Orange

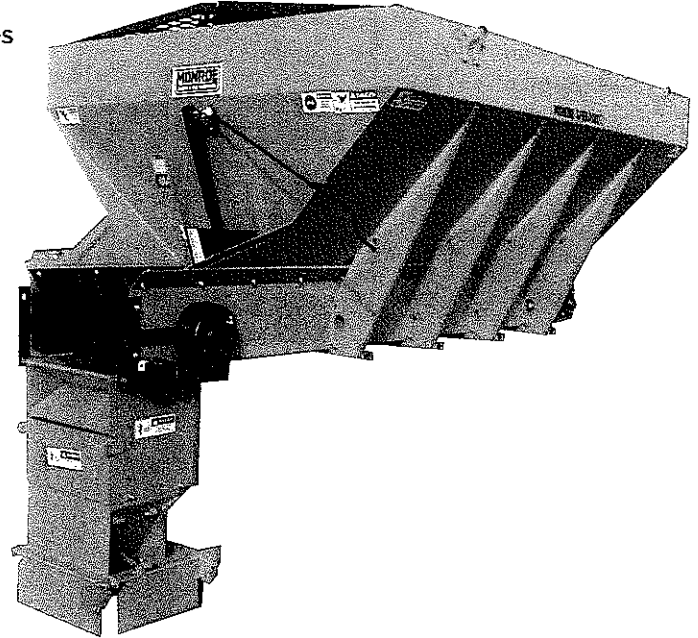

VISIT US ONLINE AT
www.monroetruck.com

Monroe Snow & Ice Control Spreaders Are Designed and Built to Last....

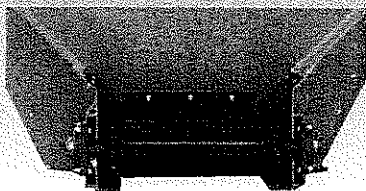

**7 Gauge, Replaceable Chain Shields
10 Gauge Hopper**

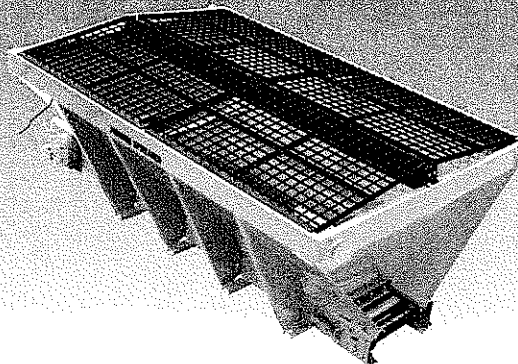

Top Screens

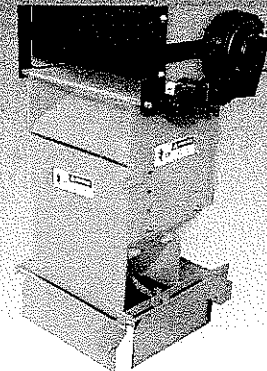

**Standard 10 Gauge Tip-Up
Adjustable Spinner Assembly/Top
Mounted Motor**

MSV Heavy Duty V-Box Spreader

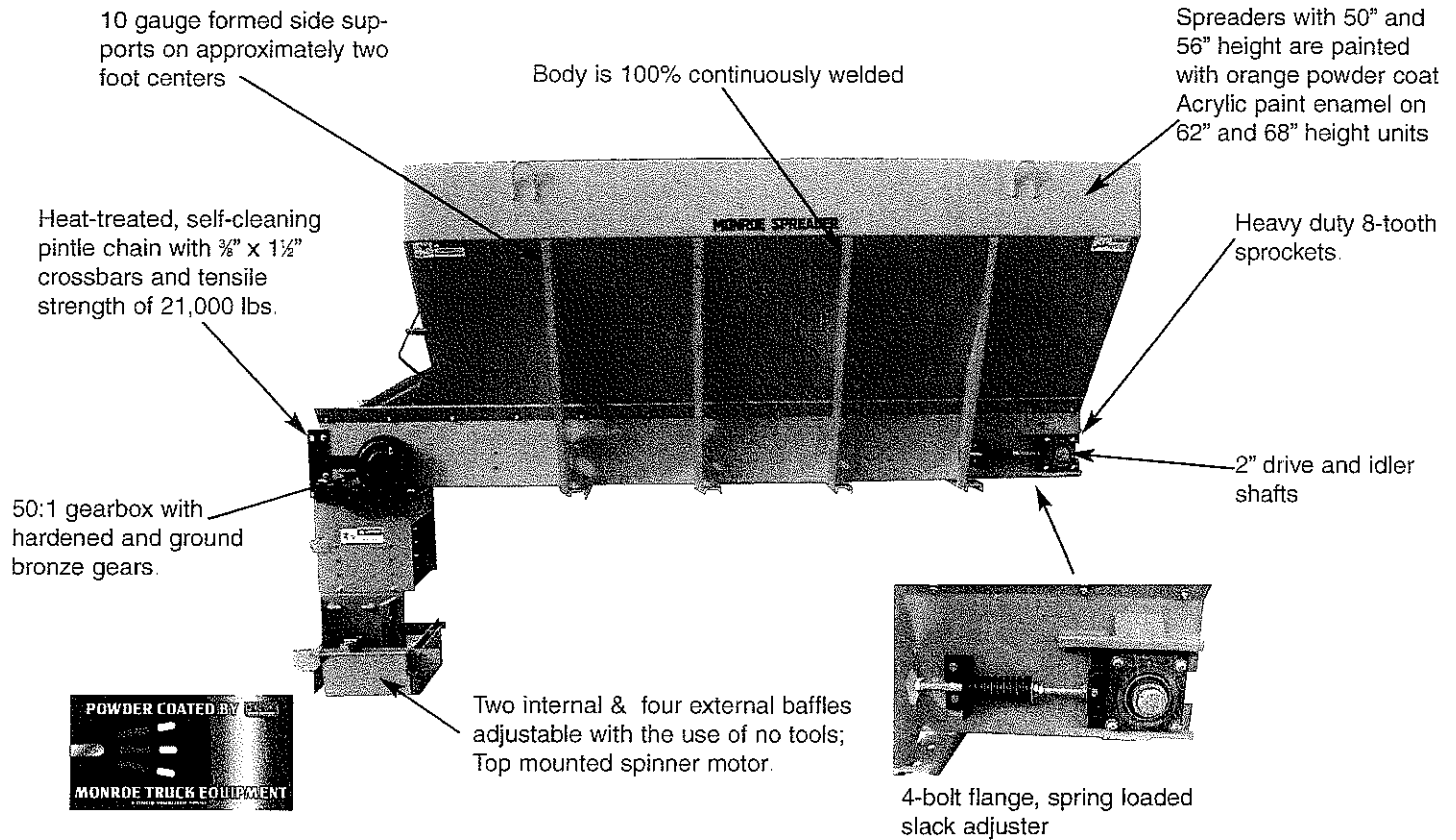

Cubic Yard Capacity-Water Level Full

Body Length

	8'	9'	10'	11'	12'	13'	14'	15'	16'	17'
50"	4.1	4.6	5.2	5.8	6.3	6.9	7.4	8.0	8.6	9.1
56"	5.1	5.8	6.5	7.2	7.9	8.6	9.2	9.9	10.6	11.3
62"	6.1	7.0	7.8	8.6	9.4	10.2	11.0	11.9	12.7	13.5
68"	7.2	8.1	9.1	10.0	11.0	11.9	12.8	13.8	14.7	15.7

Available Options

Ladders
Special Paint
1 1/2" Drive & Idler Shafts
20" UHMW Disc
Self Contained Engine
Drive Hyd. System
Chain Oiler
Chassis Mount Pipe Group
Mounting Kits

Hose Kits
Dual Flow Control Valve
Bolt-On Spinner Assembly
Rear Slack Adjusters
Grease Extensions
Corrosion-Resistant Stainless Steel
Ground Speed Controls
Inverted V
Cat Walks

25:1 Gearbox
6:1 Gearbox
Sloping Front Doghouse
Lighting Packages
Pre-Wet Systems
Skids
Leg Kits
7" Auger Conveyor in Lieu of Chain

Manufactured by:
Monroe Snow & Ice Control
1051 W. 7th Street • Monroe, WI 53566
800-880-0109 • 608-329-8105
608-328-8390 Fax
Web Site: www.monroetruck.com
E-mail: snowandicecontrol@monroetruck.com

Literature submitted is Monroe Snow & Ice Control standard equipment. All equipment bid will be built to specifications with noted exceptions listed on bid forms.

MSVSPREADER52003



1051 W. 7th Street • Monroe, WI 53566
800-880-0109 • 608-329-8105 • FAX 608-328-8390
E-mail: snowandicecontrol@monroetruck.com • Website: www.monroetruck.com

WARRANTY POLICY (West Virginia)
RFQ 708EC004
RFQ 708EC005

Uninstalled Parts and Equipment provided by Monroe Truck Equipment

Monroe Truck Equipment will provide the following limited warranty for a period of two years to the original purchaser of all uninstalled goods provided by Monroe Truck Equipment.

LIMITED WARRANTY: All goods provided by Monroe Truck Equipment (MTE) will be free from defects in material and workmanship for a period of two years from the date of purchase by the original purchaser. This limited warranty shall be the sole and exclusive remedy for any such product found to be defective. This limited warranty supercedes all previous warranties and is exclusive and in lieu of all other warranties, whether expressed or implied.

This limited warranty applies only to parts or accessories manufactured by MTE and/or provided by same. Except with respect to title, this limited warranty does not pertain to parts or accessories not manufactured and/or provided by MTE, regardless of whether such parts or accessories were selected and/or recommended by MTE. MTE will, as a service to the buyer, pass on any warranties received from the original manufacturer of MTE provided parts and/or accessories.

MTE will not under any circumstances be liable for any incidental or consequential damages whether in tort, contract, or otherwise, for any bodily injury, death, property damage, loss of use, or loss of income resulting from or in any way arising out of any goods provided by MTE, or their sale, use, or manufacture.

Any warranty claim deemed to be arising from the result of misuse, abuse, neglect, accident, improper installation, lack of maintenance, act of war (whether declared or otherwise), or act of God will be denied. Any repair or modification by the buyer or any third party, without the prior written consent of MTE, will void any possible warranty compensation. Any damage deemed to be the result of abnormal operation will not be compensated by this warranty.

Normal or special maintenance items such as fuels, fluids, tires, belts, hoses, filters, air cleaners, light bulbs, and any other items subject to normal wear and tear that are supplied in connection with goods provided by MTE are not allowed under this warranty.

Electrical and hydraulic components are not to be disassembled without the express written consent of MTE. Any disassembly of MTE provided components without prior authorization will void the applicable warranty.

Monroe Truck Equipment shall be the sole and final determining authority as it applies to the administration of this warranty policy. Purchaser acknowledges receipt of Monroe Truck Equipment Warranty Policy and agrees to be bound by same.

Any and all warranty claims must be forwarded to MTE within 10 days of defect discovery. A copy of the original Monroe Truck Equipment invoice as well as the manufacturer's model number, serial number, and date of installation must accompany all correspondence regarding said claims. MTE will, at their option, choose whether to repair or replace the defective part unless otherwise specified by the original manufacturer of said part.

Procedures for Warranty Claims Notification

For submission of any warranty claim, please contact Monroe Truck Equipment – Warranty Dept. at 800-356-8134.

The following documentation will be needed when you call for initial warranty authorization.

- A copy of the original MTE invoice
- Make, Model, and VIN or Serial number of the equipment involved.
- Part number and serial number of the part in question.
- A complete description of the problem.

The following must accompany and claim submitted to Monroe Truck Equipment:

- Documented photographs of any physical damage.
- Inspection notes by MTE personnel or MTE authorized 3rd party
- Authorization number issued by Monroe Truck Equipment - Warranty Department.

Defective parts must be returned to Monroe Truck Equipment (freight pre-paid) within 30 days of issuance of Authorization Number.

Monroe Truck Equipment reserves the right to void any warranty for failure to comply with Monroe Truck Equipment Warranty Policy.

This policy is effective November 5, 2007



Reversible & One-way Snowplows • Airport Snowplow • Heavy Duty Patrol Wing
 Heavy Duty Benching Wing • Monroe Underbody Scraper • Heavy Duty V-box Spreader
 Under Tailgate Spreader • Pickup V-box Spreader • Replacement Tailgate Spreader
 Anti-Icing/De-Icing & Vegetation Sprayer • Construction Attachments





State of West Virginia
 Department of Administration
 Purchasing Division
 2019 Washington Street East
 Post Office Box 50130
 Charleston, WV 25305-0130

Request for Quotation

RFQ NUMBER
708EC004

PAGE
1

ADDRESS CORRESPONDENCE TO ATTENTION OF
MICHAEL AUSTIN 304-558-2402

VENDOR

*709043751 304-366-4690
 MIDDLETOWN TRACTOR SALES
 2032 FAIRMONT AVE
 FAIRMONT WV 26554

SHIP TO

DIVISION OF HIGHWAYS
 EQUIPMENT DIVISION
 ROUTE 33
 BRUSHY FORK ROAD
 BUCKHANNON, WV
 26201 304-472-1750

DATE PRINTED	TERMS OF SALE	SHIP VIA	F.O.B.	FREIGHT TERMS
11/14/2007	NET30	Our Truck	Destination	Prepaid
BID OPENING DATE: 11/20/2007		BID OPENING TIME 01:30PM		

LINE	QUANTITY	UOP	CAT NO.	ITEM NUMBER	UNIT PRICE	AMOUNT
				ADDENDUM NO. 2 CHANGES TO THE SPECIFICATIONS 6.5 - WARRANTY AND SERVICE POLICY DISREGARD LAST PARAGRAPH. X6.5 WARRANTY AND SERVICE POLICY QUESTIONNAIRE PAGE 25 MUST BE COMPLETED AND SUBMITTED WITH THE BID. BID OPENING DATE AND TIME CHANGED FROM: 11/13/07 AT 1:30 P.M. TO: 11/20/07 AT 1:30 P.M. NO OTHER CHANGES		
0001	1	EA		765-66	See page 22 of original bid for	
				FIVE CUBIC YARD STAINLESS STEEL (HYDRAULIC) SPREADER		pricing.
				EXHIBIT 10		
				REQUISITION NO. :		
				ADDENDUM ACKNOWLEDGEMENT		

SEE REVERSE SIDE FOR TERMS AND CONDITIONS

SIGNATURE <i>July 14, 2007</i>	TELEPHONE 304-366-4690	DATE 11-16-07
TITLE Aftermarket Manager	FEIN 55-0547175	ADDRESS CHANGES TO BE NOTED ABOVE

WHEN RESPONDING TO RFQ, INSERT NAME AND ADDRESS IN SPACE ABOVE LABELED 'VENDOR'



State of West Virginia
 Department of Administration
 Purchasing Division
 2019 Washington Street East
 Post Office Box 50130
 Charleston, WV 25305-0130

Request for Quotation

RFQ NUMBER
708EC004

PAGE
2

ADDRESS CORRESPONDENCE TO ATTENTION OF:
MICHAEL AUSTIN 304-558-2402

*709043751 304-366-4690
 MIDDLETOWN TRACTOR SALES
 2032 FAIRMONT AVE
 FAIRMONT WV 26554

VENDOR

SHIP TO

DIVISION OF HIGHWAYS
 EQUIPMENT DIVISION
 ROUTE 33
 BRUSHY FORK ROAD
 BUCKHANNON, WV
 26201 304-472-1750

DATE PRINTED	TERMS OF SALE	SHIP VIA	F.O.B.	FREIGHT TERMS
11/14/2007				
BID OPENING DATE: 11/20/2007		BID OPENING TIME 01:30PM		

LINE	QUANTITY	UOP	CAT NO.	ITEM NUMBER	UNIT PRICE	AMOUNT
<p>I HEREBY ACKNOWLEDGE RECEIPT OF THE FOLLOWING CHECKED ADDENDUM(S) AND HAVE MADE THE NECESSARY REVISIONS TO MY PROPOSAL, PLANS AND/OR SPECIFICATION, ETC.</p> <p>ADDENDUM NO.'S:</p> <p>NO. 1 X</p> <p>NO. 2 X</p> <p>NO. 3 X</p> <p>NO. 4</p> <p>NO. 5</p> <p>I UNDERSTAND THAT FAILURE TO CONFIRM THE RECEIPT OF THE ADDENDUM(S) MAY BE CAUSE FOR REJECTION OF BIDS.</p> <p>VENDOR MUST CLEARLY UNDERSTAND THAT ANY VERBAL REPRESENTATION MADE OR ASSUMED TO BE MADE DURING ANY ORAL DISCUSSION HELD BETWEEN VENDOR'S REPRESENTATIVES AND ANY STATE PERSONNEL IS NOT BINDING. ONLY THE INFORMATION ISSUED IN WRITING AND ADDED TO THE SPECIFICATIONS BY AN OFFICIAL ADDENDUM IS BINDING.</p> <p style="text-align: center;">  SIGNATURE Middletown Tractor Sales COMPANY 11-16-07 DATE </p>						

SEE REVERSE SIDE FOR TERMS AND CONDITIONS

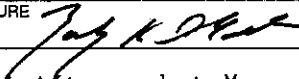
SIGNATURE 	TELEPHONE 304-366-4690	DATE 11-16-07
TITLE Aftermarket Mngr.	FEIN 550547175	ADDRESS CHANGES TO BE NOTED ABOVE

WHEN RESPONDING TO RFQ, INSERT NAME AND ADDRESS IN SPACE ABOVE LABELED 'VENDOR'



State of West Virginia
 Department of Administration
 Purchasing Division
 2019 Washington Street East
 Post Office Box 50130
 Charleston, WV 25305-0130

Request for Quotation

RFQ NUMBER
708EC004

PAGE
3

ADDRESS CORRESPONDENCE TO ATTENTION OF
MICHAEL AUSTIN 304-558-2402

*709043751 304-366-4690
 MIDDLETOWN TRACTOR SALES
 2032 FAIRMONT AVE
 FAIRMONT WV 26554

VENDOR

DIVISION OF HIGHWAYS
 EQUIPMENT DIVISION
 ROUTE 33
 BRUSHY FORK ROAD
 BUCKHANNON, WV
 26201 304-472-1750

SHIP TO

DATE PRINTED 11/14/2007	TERMS OF SALE	SHIP VIA	F.O.B.	FREIGHT TERMS
BID OPENING DATE: 11/20/2007		BID OPENING TIME 01:30PM		

LINE	QUANTITY	UOP	CAT NO	ITEM NUMBER	UNIT PRICE	AMOUNT
	REV. 11/96					
***** THIS IS THE END OF RFQ 708EC004 ***** TOTAL:						See page 22 of the original bid for pricing.

SEE REVERSE SIDE FOR TERMS AND CONDITIONS

SIGNATURE	TELEPHONE 304-366-4690	DATE 11-16-07
TITLE Aftermarket Mgr.	FEIN 550547175	ADDRESS CHANGES TO BE NOTED ABOVE

WHEN RESPONDING TO RFQ, INSERT NAME AND ADDRESS IN SPACE ABOVE LABELED 'VENDOR'

X6.5 WARRANTY AND SERVICE POLICY QUESTIONNAIRE

THIS FORM MUST BE COMPLETED IN ITS ENTIRETY BY THE SUCCESSFUL BIDDER OR MANUFACTURERS TECHNICAL REPRESENTATIVE PRIOR TO DELIVERY OF PILOT MODEL TO THE WVDOH (If additional lines are needed, make copies of form.)

1. Define the terms of the standard warranty. If not offered, so state. (Attach copy)

The standard warranty term as it applies to RFQ 708EC004 is two years. This is stated in detail in the warranty policy attached to the original bid (RFQ:708EC004)

2. Define warranty service to be performed at DOH facilities and warranty service to be performed at manufacturer's representative facility. List name and location of manufacturer's representative.

Warranty repair is to be performed at Middletown's Fairmont, WV location. However, Middletown Tractor Sales will perform on-site repairs if requested. Note: Service call fees of \$55.00 per hour for travel port to port are not covered by the warranty.

3. List locations for parts inventories that are within the State of West Virginia. Also, list availability levels, if known.

Parts inventories are stocked at Middletown Tractor Sale's Fairmont, WV location.

4. During the term of warranty, list the guarantee discount to manufacturer's published list price for parts that bidder will sell the parts to owner.

A. Terms: Net 30	Manufacturer's published list price less:	<u>0</u>	% discount
B. Terms: Net 60	Manufacturer's published list price less:	<u>0</u>	% discount
C. Terms: Net 90	Manufacturer's published list price less:	<u>0</u>	% discount

5. During the term of warranty, will all manufacturers or engineering improvements be submitted to Division of Highways?

YES NO

6. During the term of warranty, list the guaranteed rates charged for repair to the unit.

A. Shop Rate \$ 51.00 per mechanic hour

B. Travel Time Charge (Specify if one-way) \$ 55.00 per mechanic hour; port to port

C. Mileage Charge (Specify if one-way) \$ N/A per vehicle mile; port to port _____

D. Field Mechanic Rate \$ 55.00 per mechanic hour

E. Specify period of time that prices are in effect: Calendar year 2008 or unless otherwise submitted in writing to the purchasing division.

F. Surcharge for miscellaneous items: 0 %



State of West Virginia
 Department of Administration
 Purchasing Division
 2019 Washington Street East
 Post Office Box 50130
 Charleston, WV 25305-0130

**Request for
 Quotation**

RFQ NUMBER
 708EC004

PAGE
 1

ADDRESS CORRESPONDENCE TO ATTENTION OF
 MICHAEL AUSTIN
 304-558-2402

*709043751 304-366-4690
 MIDDLETOWN TRACTOR SALES
 2032 FAIRMONT AVE
 FAIRMONT WV 26554

RODNEY

SHIP TO

DIVISION OF HIGHWAYS
 EQUIPMENT DIVISION
 ROUTE 33
 BRUSHY FORK ROAD
 BUCKHANNON, WV
 26201 304-472-1750

DATE PRINTED 11/14/2007	TERMS OF SALE NET30	SHIP VIA Truck	F.O.B. Destination	FREIGHT TERMS Prepaid
BID OPENING DATE: 11/20/2007		BID OPENING TIME 01:30PM		

LINE	QUANTITY	UOP	CAT NO	ITEM NUMBER	UNIT PRICE	AMOUNT
				ADDENDUM NO. 3		
				X6.5 WARRANTY AND SERVICE POLICY QUESTIONNAIRE		
				IF THE ORIGINAL BID HAS BEEN SUBMITTED TO THE PURCHASING DIVISION PREVIOUSLY, BIDDERS MAY SUBMIT PAGE 25 WITH THE ADDENDUM TO THE PURCHASING DIVISION FOR BID OPENING 11/20/07 AT 1:30 P.M. IN A SEPARATE SEALED ENVELOPE.		
				NO OTHER CHANGES		
0001	1	EA		765-66	See page 22 of the original bid for pricing.	
				FIVE CUBIC YARD STAINLESS STEEL (HYDRAULIC) SPREADER		
				EXHIBIT 10		
				REQUISITION NO.:		
				ADDENDUM ACKNOWLEDGEMENT		
				I HEREBY ACKNOWLEDGE RECEIPT OF THE FOLLOWING CHECKED ADDENDUM(S) AND HAVE MADE THE NECESSARY REVISIONS TO MY PROPOSAL, PLANS AND/OR SPECIFICATION, ETC.		
				ADDENDUM NO.'S:		

SEE REVERSE SIDE FOR TERMS AND CONDITIONS

SIGNATURE <i>[Signature]</i>	TELEPHONE 304-366-4690	DATE 11-16-07
TITLE Aftermarket Mngr.	FEN 550547175	ADDRESS CHANGES TO BE NOTED ABOVE

WHEN RESPONDING TO RFQ, INSERT NAME AND ADDRESS IN SPACE ABOVE LABELED 'VENDOR'



State of West Virginia
 Department of Administration
 Purchasing Division
 2019 Washington Street East
 Post Office Box 50130
 Charleston, WV 25305-0130

**Request for
 Quotation**

RFQ NUMBER
 .708EC004

PAGE
 2

ADDRESS CORRESPONDENCE TO ATTENTION OF
 MICHAEL AUSTIN
 304-558-2402

*709043751 304-366-4690
 MIDDLETOWN TRACTOR SALES
 2032 FAIRMONT AVE
 FAIRMONT WV 26554

DIVISION OF HIGHWAYS
 EQUIPMENT DIVISION
 ROUTE 33
 BRUSHY FORK ROAD
 BUCKHANNON, WV
 26201 304-472-1750

BIDDING

SHIP TO

DATE PRINTED 11/14/2007	TERMS OF SALE	SHIP VIA	FOB	FREIGHT TERMS
BID OPENING DATE: 11/20/2007		BID OPENING TIME 01:30PM		

LINE	QUANTITY	UOP	CAT NO	ITEM NUMBER	UNIT PRICE	AMOUNT
NO. 1	X					
NO. 2	X					
NO. 3	X					
NO. 4						
NO. 5						
<p>I UNDERSTAND THAT FAILURE TO CONFIRM THE RECEIPT OF TH ADDENDUM(S) MAY BE CAUSE FOR REJECTION OF BIDS.</p> <p>VENDOR MUST CLEARLY UNDERSTAND THAT ANY VERBAL REPRESENTATION MADE OR ASSUMED TO BE MADE DURING ANY ORAL DISCUSSION HELD BETWEEN VENDOR'S REPRESENTATIVES AND ANY STATE PERSONNEL IS NOT BINDING. ONLY THE INFORMATION ISSUED IN WRITING AND ADDED TO THE SPECIFICATIONS BY AN OFFICIAL ADDENDUM IS BINDING.</p>						
				SIGNATURE		
				Middletown Tractor Sales		
				COMPANY		
				11-16-07		
				DATE		
REV. 11/96						

SEE REVERSE SIDE FOR TERMS AND CONDITIONS

SIGNATURE <i>[Signature]</i>	TELEPHONE 304-366-4690	DATE 11-16-07
TITLE Aftermarket Mngr.	FEIN 550547175	ADDRESS CHANGES TO BE NOTED ABOVE

WHEN RESPONDING TO RFQ, INSERT NAME AND ADDRESS IN SPACE ABOVE LABELED 'VENDOR'