



State of West Virginia
 Department of Administration
 Purchasing Division
 2019 Washington Street East
 Post Office Box 50130
 Charleston, WV 25305-0130

Request for Quotation

RFQ NUMBER
PRI3972

PAGE
1

ADDRESS CORRESPONDENCE TO ATTENTION OF
JOHN ABBOTT
304-558-2544

VENDOR
 *709024742 800-234-4900
NORIX GROUP INC
1000 ATLANTIC DRIVE

WEST CHICAGO IL 60185

SHIP TO
WV PRISON INDUSTRIES

617 LEON SULLIVAN WAY
CHARLESTON, WV
25301 304-558-2945

| | | | | |
|-----------------------------------|--------------------------------|-----------------------------------|------------------------------|---------------|
| DATE PRINTED 05/10/2007 | TERMS OF SALE Net 30 | SHIP VIA Common Carrier | F.O.B. Destination | FREIGHT TERMS |
|-----------------------------------|--------------------------------|-----------------------------------|------------------------------|---------------|

BID OPENING DATE: **05/30/2007** **BID OPENING TIME 01:30PM**

| LINE | QUANTITY | UOP | CAT. NO. | ITEM NUMBER | UNIT PRICE | AMOUNT |
|---|----------|-----|----------|-------------|------------|---------|
| REQUEST FOR QUOTATION | | | | | | |
| THE PURCHASING DIVISION IS SOLICITING BIDS FOR THE WEST VIRGINIA CORRECTIONAL INDUSTRIES TO PROVIDE PROPERTY STORAGE BOXES TO THE HUTTONSVILLE CORRECTIONAL CENTER. | | | | | | |
| ATTACHMENTS: 1. SPECIFICATIONS 2. AFFIDAVIT | | | | | | |
| QTY. 938 EXTRA LARGE PROPERTY STORAGE BOXES | | | | | | \$76.71 |
| QTY. 938 EXTRA LARGE PROPERTY STORAGE BOX LIDS | | | | | | \$35.98 |
| DELIVERY SHALL BE MADE TO: HUTTONSVILLE CORRECTIONAL CENTER RT. 250 SOUTH, BOX 1 HUTTONSVILLE, WV 26273 | | | | | | |
| 0001 | 1 | LS | | 425-53 | | |
| PROPERTY STORAGE BOXES | | | | | | |
| VENDOR PREFERENCE CERTIFICATE | | | | | | |
| CERTIFICATION AND APPLICATION* IS HEREBY MADE FOR PREFERENCE IN ACCORDANCE WITH WEST VIRGINIA CODE, 5A-3-37 (DOES NOT APPLY TO CONSTRUCTION CONTRACTS). | | | | | | |

RECEIVED
2007 MAY 25 A 10:10
 PURCHASING DIVISION
 STATE OF WV

SEE REVERSE SIDE FOR TERMS AND CONDITIONS

| | | |
|--------------------------------------|----------------------------------|-----------------------------------|
| SIGNATURE | TELEPHONE 800-234-4900 | DATE 5-24-07 |
| TITLE Vice President Sales | FEIN 36-3257149 | ADDRESS CHANGES TO BE NOTED ABOVE |

WHEN RESPONDING TO RFQ, INSERT NAME AND ADDRESS IN SPACE ABOVE LABELED 'VENDOR'



State of West Virginia
 Department of Administration
 Purchasing Division
 2019 Washington Street East
 Post Office Box 50130
 Charleston, WV 25305-0130

Request for Quotation

RFQ NUMBER
PRI3972

PAGE
2

ADDRESS CORRESPONDENCE TO ATTENTION OF:
**JOHN ABBOTT
 304-558-2544**

***709024742 800-234-4900**
NORIX GROUP INC
1000 ATLANTIC DRIVE
WEST CHICAGO IL 60185

WV PRISON INDUSTRIES
617 LEON SULLIVAN WAY
CHARLESTON, WV
25301 304-558-2945

| | | | | |
|--|--------------------------------|------------------------------------|-----------------------------|---------------|
| DATE PRINTED 05/10/2007 | TERMS OF SALE Net 30 | SHIP VIA Common Carrier | F.O.B Destination | FREIGHT TERMS |
| BID OPENING DATE: 05/30/2007 | | BID OPENING TIME 01:30PM | | |

| LINE | QUANTITY | UOP | CAT. NO. | ITEM NUMBER | UNIT PRICE | AMOUNT |
|---|----------|-----|----------|-------------|------------|--------|
| <p>A. APPLICATION IS MADE FOR 2.5% PREFERENCE FOR THE REASON CHECKED:</p> <p>() BIDDER IS AN INDIVIDUAL RESIDENT VENDOR AND HAS RESIDED CONTINUOUSLY IN WEST VIRGINIA FOR FOUR (4) YEARS IMMEDIATELY PRECEDING THE DATE OF THIS CERTIFICATION; OR</p> <p>() BIDDER IS A PARTNERSHIP, ASSOCIATION OR CORPORATION RESIDENT VENDOR AND HAS MAINTAINED ITS HEAD-QUARTERS OR PRINCIPAL PLACE OF BUSINESS CONTINUOUSLY IN WEST VIRGINIA FOR FOUR (4) YEARS IMMEDIATELY PRECEDING THE DATE OF THIS CERTIFICATION; OR 80% OF THE OWNERSHIP INTEREST OF BIDDER IS HELD BY ANOTHER INDIVIDUAL, PARTNERSHIP, ASSOCIATION OR CORPORATION RESIDENT VENDOR WHO HAS MAINTAINED ITS HEADQUARTERS OR PRINCIPAL PLACE OF BUSINESS CONTINUOUSLY IN WEST VIRGINIA FOR FOUR (4) YEARS IMMEDIATELY PRECEDING THE DATE OF THIS CERTIFICATION; OR</p> <p>() BIDDER IS A CORPORATION NONRESIDENT VENDOR WHICH HAS AN AFFILIATE OR SUBSIDIARY WHICH EMPLOYS A MINIMUM OF ONE HUNDRED STATE RESIDENTS AND WHICH HAS MAINTAINED ITS HEADQUARTERS OR PRINCIPAL PLACE OF BUSINESS WITHIN WEST VIRGINIA CONTINUOUSLY FOR THE FOUR (4) YEARS IMMEDIATELY PRECEDING THE DATE OF THIS CERTIFICATION.</p> <p>B. APPLICATION IS MADE FOR 2.5% PREFERENCE FOR THE REASON CHECKED:</p> <p>() BIDDER IS A RESIDENT VENDOR WHO CERTIFIES THAT, DURING THE LIFE OF THE CONTRACT, ON AVERAGE AT LEAST 75% OF THE EMPLOYEES WORKING ON THE PROJECT BEING BID ARE RESIDENTS OF WEST VIRGINIA WHO HAVE RESIDED IN THE STATE CONTINUOUSLY FOR THE TWO YEARS IMMEDIATELY</p> | | | | | | |

SEE REVERSE SIDE FOR TERMS AND CONDITIONS

| | | |
|--------------------------------------|----------------------------------|-----------------------------------|
| SIGNATURE | TELEPHONE 800-234-4900 | DATE 5-24-07 |
| TITLE Vice President Sales | FEIN 36-3257149 | ADDRESS CHANGES TO BE NOTED ABOVE |

WHEN RESPONDING TO RFQ, INSERT NAME AND ADDRESS IN SPACE ABOVE LABELED 'VENDOR'



State of West Virginia
 Department of Administration
 Purchasing Division
 2019 Washington Street East
 Post Office Box 50130
 Charleston, WV 25305-0130

Request for Quotation

RFQ NUMBER
PRI3972

PAGE
3

ADDRESS CORRESPONDENCE TO ATTENTION OF:
JOHN ABBOTT
304-558-2544

VENDOR

*709024742 800-234-4900
NORIX GROUP INC
1000 ATLANTIC DRIVE

WEST CHICAGO IL 60185

SHIP TO

WV PRISON INDUSTRIES

617 LEON SULLIVAN WAY
CHARLESTON, WV
25301 304-558-2945

| | | | | |
|--|--------------------------------|------------------------------------|-----------------------------|---------------|
| DATE PRINTED 05/10/2007 | TERMS OF SALE Net 30 | SHIP VIA Common Carrier | F.O.B Destination | FREIGHT TERMS |
| BID OPENING DATE: 05/30/2007 | | BID OPENING TIME 01:30PM | | |

| LINE | QUANTITY | UOP | CAT NO. | ITEM NUMBER | UNIT PRICE | AMOUNT |
|---|----------|-----|---------|-------------|------------|--------|
| <p>PRECEDING SUBMISSION OF THIS BID; OR () BIDDER IS A NONRESIDENT VENDOR EMPLOYING A MINIMUM OF ONE HUNDRED STATE RESIDENTS OR IS A NONRESIDENT VENDOR WITH AN AFFILIATE OR SUBSIDIARY WHICH MAINTAINS ITS HEADQUARTERS OR PRINCIPAL PLACE OF BUSINESS WITHIN WEST VIRGINIA EMPLOYING A MINIMUM OF ONE HUNDRED STATE RESIDENTS WHO CERTIFIES THAT, DURING THE LIFE OF THE CONTRACT, ON AVERAGE AT LEAST 75% OF THE EMPLOYEES OR BIDDERS' AFFILIATE'S OR SUBSIDIARY'S EMPLOYEES ARE RESIDENTS OF WEST VIRGINIA WHO HAVE RESIDED IN THE STATE CONTINUOUSLY FOR THE TWO YEARS IMMEDIATELY PRECEDING SUBMISSION OF THIS BID.</p> <p>BIDDER UNDERSTANDS IF THE SECRETARY OF TAX & REVENUE DETERMINES THAT A BIDDER RECEIVING PREFERENCE HAS FAILED TO CONTINUE TO MEET THE REQUIREMENTS FOR SUCH PREFERENCE, THE SECRETARY MAY ORDER THE DIRECTOR OF PURCHASING TO: (A) RESCIND THE CONTRACT OR PURCHASE ORDER ISSUED; OR (B) ASSESS A PENALTY AGAINST SUCH BIDDER IN AN AMOUNT NOT TO EXCEED 5% OF THE BID AMOUNT AND THAT SUCH PENALTY WILL BE PAID TO THE CONTRACTING AGENCY OR DEDUCTED FROM ANY UNPAID BALANCE ON THE CONTRACT OR PURCHASE ORDER.</p> <p>BY SUBMISSION OF THIS CERTIFICATE, BIDDER AGREES TO DISCLOSE ANY REASONABLY REQUESTED INFORMATION TO THE PURCHASING DIVISION AND AUTHORIZES THE DEPARTMENT OF TAX AND REVENUE TO DISCLOSE TO THE DIRECTOR OF PURCHASING APPROPRIATE INFORMATION VERIFYING THAT BIDDER HAS PAID THE REQUIRED BUSINESS TAXES, PROVIDED THAT SUCH INFORMATION DOES NOT CONTAIN THE AMOUNTS OF TAXES PAID NOR ANY OTHER INFORMATION DEEMED BY THE TAX COMMISSIONER TO BE CONFIDENTIAL.</p> <p>UNDER PENALTY OF LAW FOR FALSE SWEARING (WEST VIRGINIA</p> | | | | | | |

SEE REVERSE SIDE FOR TERMS AND CONDITIONS

| | | |
|--------------------------------------|----------------------------------|-----------------------------------|
| SIGNATURE | TELEPHONE 800-234-4900 | DATE 5-24-07 |
| TITLE Vice President Sales | FEIN 36-3257149 | ADDRESS CHANGES TO BE NOTED ABOVE |

WHEN RESPONDING TO RFQ, INSERT NAME AND ADDRESS IN SPACE ABOVE LABELED 'VENDOR'



State of West Virginia
 Department of Administration
 Purchasing Division
 2019 Washington Street East
 Post Office Box 50130
 Charleston, WV 25305-0130

Request for Quotation

RFQ NUMBER:
PRI3972

PAGE:
4

ADDRESS CORRESPONDENCE TO ATTENTION OF:
**JOHN ABBOTT
 304-558-2544**

VENDOR

*709024742 800-234-4900
**NORIX GROUP INC
 1000 ATLANTIC DRIVE
 WEST CHICAGO IL 60185**

SHIP TO

**WV PRISON INDUSTRIES
 617 LEON SULLIVAN WAY
 CHARLESTON, WV
 25301 304-558-2945**

| | | | | |
|--|--------------------------------|------------------------------------|------------------------------|---------------|
| DATE PRINTED 05/10/2007 | TERMS OF SALE Net 30 | SHIP VIA Common Carrier | F.O.B. Destination | FREIGHT TERMS |
| BID OPENING DATE: 05/30/2007 | | BID OPENING TIME 01:30PM | | |

| LINE | QUANTITY | UOP | CAT NO | ITEM NUMBER | UNIT PRICE | AMOUNT |
|---|----------|-----|--------|-------------|------------|--------|
| <p>CODE 61-5-3), BIDDER HEREBY CERTIFIES THAT THIS CERTIFICATE IS TRUE AND ACCURATE IN ALL RESPECTS; AND THAT IF A CONTRACT IS ISSUED TO BIDDER AND IF ANYTHING CONTAINED WITHIN THIS CERTIFICATE CHANGES DURING THE TERM OF THE CONTRACT, BIDDER WILL NOTIFY THE PURCHASING DIVISION IN WRITING IMMEDIATELY.</p> <p>BIDDER: <u>Norix Group, Inc.</u></p> <p>DATE: <u>5/24/2007</u></p> <p>SIGNED: <u><i>[Signature]</i></u></p> <p>TITLE: <u>Vice President Sales</u></p> <p>* CHECK ANY COMBINATION OF PREFERENCE CONSIDERATION(S) IN EITHER "A" OR "B", OR BOTH "A" AND "B" WHICH YOU ARE ENTITLED TO RECEIVE. YOU MAY REQUEST UP TO THE MAXIMUM 5% PREFERENCE FOR BOTH "A" AND "B". (REV. 12/00)</p> <p>NOTICE</p> <p>A SIGNED BID MUST BE SUBMITTED TO:</p> <p>DEPARTMENT OF ADMINISTRATION PURCHASING DIVISION BUILDING 15 2019 WASHINGTON STREET, EAST CHARLESTON, WV 25305-0130</p> | | | | | | |

| | | | |
|---|----------------------------------|-----------------------------------|--|
| SEE REVERSE SIDE FOR TERMS AND CONDITIONS | | | |
| SIGNATURE <u><i>[Signature]</i></u> | TELEPHONE 800-234-4900 | DATE 5-24-07 | |
| TITLE Vice President Sales | FEIN 36-3257149 | ADDRESS CHANGES TO BE NOTED ABOVE | |

WHEN RESPONDING TO RFQ, INSERT NAME AND ADDRESS IN SPACE ABOVE LABELED 'VENDOR'



State of West Virginia
 Department of Administration
 Purchasing Division
 2019 Washington Street East
 Post Office Box 50130
 Charleston, WV 25305-0130

Request for Quotation

RFQ NUMBER
PRI3972

PAGE
5

ADDRESS CORRESPONDENCE TO ATTENTION OF:
JOHN ABBOTT
304-558-2544

VENDOR

*709024742 800-234-4900
NORIX GROUP INC
1000 ATLANTIC DRIVE
WEST CHICAGO IL 60185

SHIP TO

WV PRISON INDUSTRIES
617 LEON SULLIVAN WAY
CHARLESTON, WV
25301 304-558-2945

| DATE PRINTED | TERMS OF SALE | SHIP VIA | F.O.B | FREIGHT TERMS |
|------------------------------|---------------|--------------------------|-------------|---------------|
| 05/10/2007 | Net 30 | Common Carrier | Destination | |
| BID OPENING DATE: 05/30/2007 | | BID OPENING TIME 01:30PM | | |

| LINE | QUANTITY | UOP | CAT. NO. | ITEM NUMBER | UNIT PRICE | AMOUNT |
|--|----------|-----|----------|-------------|------------|--------|
| <p>THE BID SHOULD CONTAIN THIS INFORMATION ON THE FACE OF THE ENVELOPE OR THE BID MAY NOT BE CONSIDERED:</p> <p>SEALED BID</p> <p>BUYER: JOHN ABBOTT-----</p> <p>RFQ. NO.: PRI3972-----</p> <p>BID OPENING DATE: 05/30/2007-----</p> <p>BID OPENING TIME: 1:30 PM-----</p> <p>PLEASE PROVIDE A FAX NUMBER IN CASE IT IS NECESSARY TO CONTACT YOU REGARDING YOUR BID:</p> <p>---(630) 231-4343-----</p> <p>CONTACT PERSON (PLEASE PRINT CLEARLY):</p> <p>--- Jessica Earley-----</p> <p>***** THIS IS THE END OF RFQ PRI3972 ***** TOTAL: \$ 105,703.22</p> | | | | | | |

SEE REVERSE SIDE FOR TERMS AND CONDITIONS

SIGNATURE  TELEPHONE 800-234-4900 DATE 5-24-07

TITLE Vice President Sales FEIN 36-3257149 ADDRESS CHANGES TO BE NOTED ABOVE

WHEN RESPONDING TO RFQ, INSERT NAME AND ADDRESS IN SPACE ABOVE LABELED 'VENDOR'

Norix Group, Inc.

NORIX

STANDARD TERMS & CONDITIONS, JANUARY 1, 2007

ACCEPTANCE

Norix reserves the right to refuse an order, in whole or part, when the type or quantity of goods or credit worthiness of the customer is not satisfactory. Possession of this price list does not constitute a right to purchase Norix products. Prices, terms and conditions of sale are subject to change. All sales will be made at prices prevailing at the time of order. If shipment is delayed at customer request, prices at time of shipment will prevail. A complete order is defined as having no missing information and issued by a bona fide business or facility with good credit.

ACKNOWLEDGEMENTS

All orders are manufactured and shipped according to the acknowledgement and its terms and conditions. It is the customer's responsibility to check for and document any discrepancies on the acknowledgement and to notify Norix immediately in writing.

ADA COMPLIANT



This product meets the Americans with Disabilities Act Accessibility Guidelines as published by the Department of Justice on December 21, 1992 under Proposed Rules for Courthouses (Section 11) and Detention and Correctional Facilities (Section 12).

CANCELLATION & CHARGES

Cancellations and change orders are subject to Norix approval. A cancellation or change order charge will apply if any cost for material or labor has been incurred prior to notification from the customer. A restocking charge of 25% will apply.

CREDIT & PAYMENT TERMS

Net 30 days from invoice shipment date. Past due accounts will be subject to a finance charge of 1.75% per month (pro-rated at 21% per annum or the legal limit) which will be added to the unpaid balance of invoices not paid within 30 days. We accept Visa, MasterCard and American Express.

FREIGHT

All shipments are F.O.B. West Chicago IL 60185, unless otherwise specified. Standard delivery is on a dock-to-dock basis utilizing a 53' semi-trailer. Unless arranged for in advance and included as part of a formal Norix price quote, special requests such as "Lift Gate Trucks", "Exact Day Delivery", and "Inside Delivery", will incur an additional charge of \$250 each. Special requests, such as those listed above, must appear on customer's purchase order. Special delivery requests received after the order is acknowledged will be considered a change order. "Exact Time Delivery" is not available. Deliveries required to be received in less than 53' semi-trailers will incur additional charges and must be requested in advance of shipment. Partial shipments at the customer's request will result in additional freight charges. Norix will not in any event be liable to any customer for special, incidental or consequential damages due to late delivery or non-delivery of goods for any reason.

FREIGHT DAMAGE (VISIBLE)

To receive claims consideration, the consignee must inspect the freight for damage and record the specifics of that damage on the bill of lading. Under National Motor Freight Classification (NMFC) rules, the consignee does not have the right to open and inspect all of the shipping containers prior to signing for the freight. However, if the condition of the shipping package is such that there is good reason to suspect damage, the consignee has the right and should perform an inspection. It is the responsibility of the receiver of the shipment to inspect for item damage within 15 days of receipt of the shipment and report immediately any discrepancies to Norix customer service.

FREIGHT DAMAGE (CONCEALED)

When damage is discovered after delivery, it should be reported to Norix immediately. The freight and shipping container should be retained until a disposition is given. It is the responsibility of the receiver of the shipment to inspect for item damage within 15 days of receipt of the shipment and report immediately any discrepancies to Norix customer service.

FREIGHT (REFUSAL)

Customer is liable for all freight charges when refusing to accept delivery of product under terms of acknowledged shipping schedule.

FREIGHT (SHORTAGES)

The Bill of Lading lists the number of cartons, sleeves (of stack chairs) or skids you should expect to receive on this shipment. Any discrepancies must be noted on the delivery receipt. A Packing List is included with every shipment. It is the responsibility of the receiver of the shipment to inspect for item shortages within 15 days of receipt of the shipment and report immediately any discrepancies to Norix customer service.

INSPECTION

It is the customer's responsibility and obligation to implement a procedure to conduct regular and timely inspections and maintenance of all Norix products to assure that unsafe conditions do not evolve or exist. Further, it is the customer's responsibility to remove unsafe or defective products from service immediately, including any situations where abuse is suspected or determined to be a potential problem.

QUICK SHIP



Any items designated Quick Ship(QS) will normally ship within 5 working days after receipt of a complete order. Quantities are limited and are available on a first come first served basis.

RETURNED GOODS

Returns will be allowed for unused products in original packaging only after a *Return Goods Authorization* has been requested by the customer and approved by Norix. Return Goods Authorization requests should be directed to a Norix Customer Service Representative. Return goods subject to 25% restocking charge.

STORAGE & HANDLING

All orders are acknowledged with an estimated ship date. Failure to accept delivery of an order based on the estimated ship date will subject your order to warehouse storage charges. Norix will assess storage and handling charges of 1.75% per month or portions thereof on orders that are delayed.

WARRANTY

NORIX warrants, to its original purchaser, all of its products to be free from defects in workmanship and materials for specified periods of time depending on product following date of shipment. Norix makes no other warranty, express or implied, to customer, its customers or any users of the goods, including without limitation any implied warranty of merchantability of the goods or of the fitness of the goods for a particular purpose.



Property Box (a.k.a. Tank Box)

Property storage boxes for inmate records and/or personal possessions. Designed and engineered for institutional durability. Suitable for continuous daily use in a correctional environment.

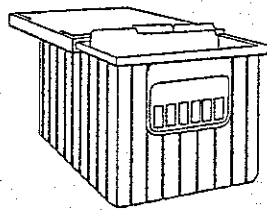

Model #: PB150 (Legal/Letter)

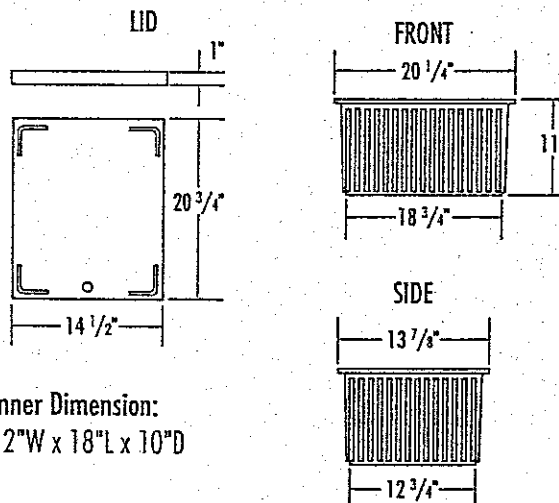

Inner Dimension:
12"W x 18"L x 10"D

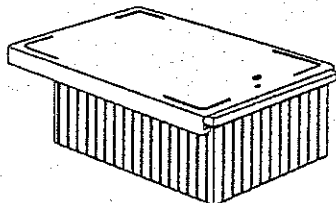

Model #: PB200 (Standard)

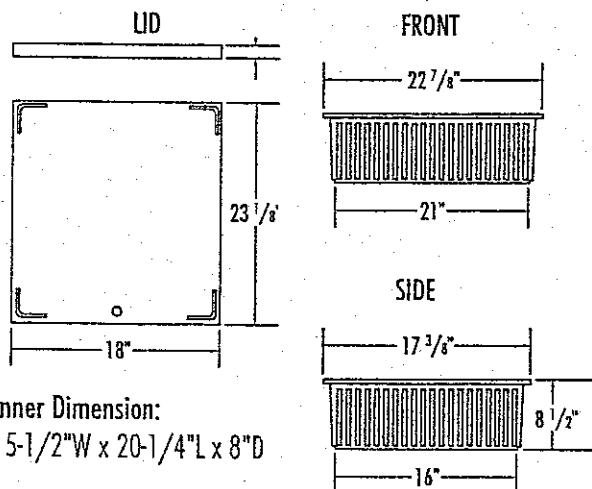

Inner Dimension:
15-1/2"W x 20-1/4"L x 8"D

Fabrication:

Full height molded-in vertical ribs every 1-1/4". 1/2" x 7/8" top flange provides maximum strength and rigidity. Capable of nesting for stable stacking.

Material:

Injection molded from structural polyethylene. 100% recyclable.

Flammability:

Certified to pass the following flammability standards:

- State of California, Technical Bulletin No. 133, Flammability Test Procedure for Seating Furniture for Use in Public Occupancies.

Quality & Testing Standards, conforms to:

- Minimum sustained static load of 3000 lbs. for four hours.

Color:

Grey.

Weight:

Box:

- PB150 (Legal/Letter): 9.5 lbs.
- PB200 (Standard): 9 lbs.
- PB300 (Large): 12 lbs.
- PB350 (Extra Large): 22.5 lbs.

Lid:

- PBL401: 3.5 lbs.
- PBL400: 4 lbs.
- PBL400: 4 lbs.
- PBL402: 8 lbs.

Options:

Sliding lid. Padlock. Under bunk rail sets.

Assembly:

None required.

Installation:

None required.

Warranty:

1 year limited replacement warranty.

Maintenance:

Easily cleaned with a damp cloth and mild soap solution.

Filing System:

- 12600 Institutional Furniture
- 11197 Correctional Furniture

Continued on back.

Norix Group, Inc. • 1000 Atlantic Drive, West Chicago, IL 60185-5101

Phone: 800-234-4900 • 630-231-1331 • Fax: 630-231-4343 • Email: furniture@norix.com • www.norix.com
Specifications subject to change without notice. ©2006 Norix Group, Inc. All Rights Reserved. Printed in U.S.A. 6/06

Property Box (a.k.a. Tank Box)

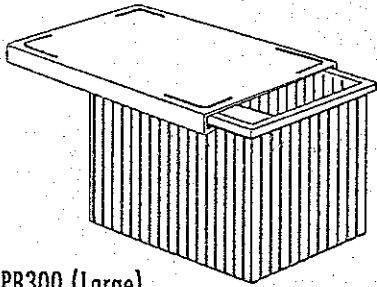

Model #: PB300 (Large)

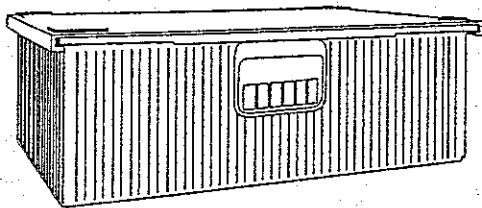
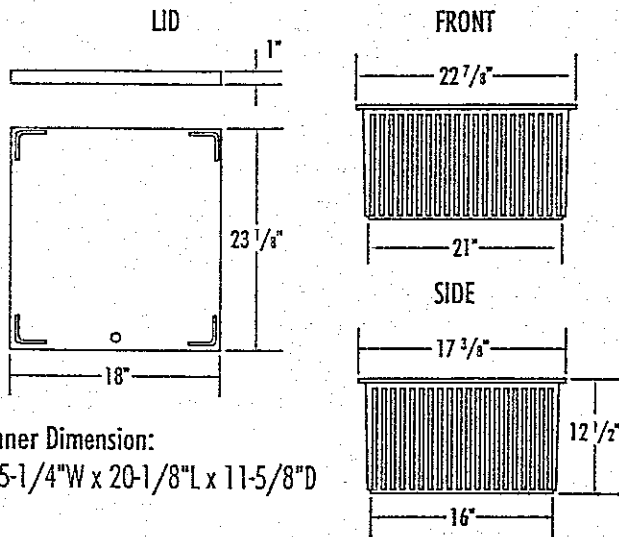

Model #: PB350 (Extra Large)

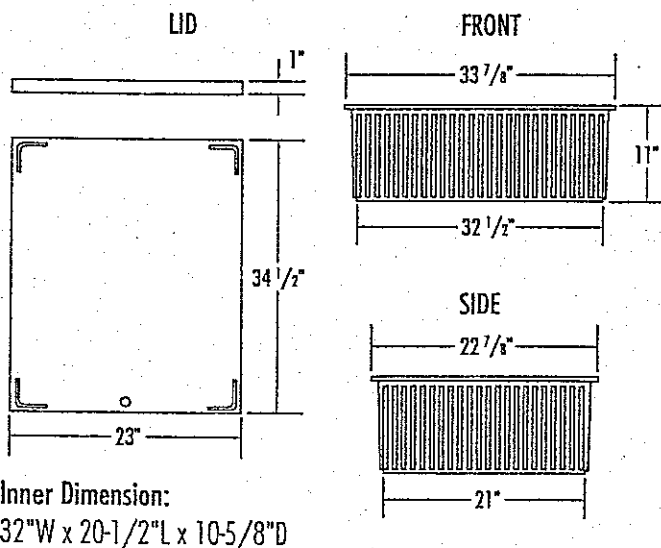

STATE OF WEST VIRGINIA
Purchasing Division

PURCHASING AFFIDAVIT

West Virginia Code §5A-3-10a states: No contract or renewal of any contract may be awarded by the state or any of its political subdivisions to any vendor or prospective vendor when the vendor or prospective vendor or a related party to the vendor or prospective vendor is a debtor and the debt owned is an amount greater than one thousand dollars in the aggregate

DEFINITIONS:

"Debt" means any assessment, premium, penalty, fine, tax or other amount of money owed to the state or any of its political subdivisions because of a judgment, fine, permit violation, license assessment, defaulted workers' compensation premium, penalty or other assessment presently delinquent or due and required to be paid to the state or any of its political subdivisions, including any interest or additional penalties accrued thereon.

"Debtor" means any individual, corporation, partnership, association, limited liability company or any other form or business association owing a debt to the state or any of its political subdivisions. "Political subdivision" means any county commission; municipality; county board of education; any instrumentality established by a county or municipality; any separate corporation or instrumentality established by one or more counties or municipalities, as permitted by law; or any public body charged by law with the performance of a government function or whose jurisdiction is coextensive with one or more counties or municipalities. "Related party" means a party, whether an individual, corporation, partnership, association, limited liability company or any other form or business association or other entity whatsoever, related to any vendor by blood, marriage, ownership or contract through which the party has a relationship of ownership or other interest with the vendor so that the party will actually or by effect receive or control a portion of the benefit, profit or other consideration from performance of a vendor contract with the party receiving an amount that meets or exceeds five percent of the total contract amount.

EXCEPTION: The prohibition of this section does not apply where a vendor has contested any tax administered pursuant to chapter eleven of this code, workers' compensation premium, permit fee or environmental fee or assessment and the matter has not become final or where the vendor has entered into a payment plan or agreement and the vendor is not in default of any of the provisions of such plan or agreement.

LICENSING: Vendors must be licensed and in good standing in accordance with any and all state and local laws and requirements by any state or local agency of West Virginia, including, but not limited to, the West Virginia Secretary of State's Office, the West Virginia Tax Department, West Virginia Insurance Commission, or any other state agencies or political subdivision. Furthermore, the vendor must provide all necessary releases to obtain information to enable the Director or spending unit to verify that the vendor is licensed and in good standing with the above entities.

CONFIDENTIALITY: The vendor agrees that he or she will not disclose to anyone, directly or indirectly, any such personally identifiable information or other confidential information gained from the agency, unless the individual who is the subject of the information consents to the disclosure in writing or the disclosure is made pursuant to the agency's policies, procedures and rules. Vendors should visit www.state.wv.us/admin/purchase/privacy for the Notice of Agency Confidentiality Policies.

Under penalty of law for false swearing (West Virginia Code, §61-5-3), it is hereby certified that the vendor acknowledges the information in this said affidavit and are in compliance with the requirements as stated.

Vendor's Name: Norix Group, Inc.

Authorized Signature: _____

Date: 5/24/2007