



State of West Virginia
 Department of Administration
 Purchasing Division
 2019 Washington Street East
 Post Office Box 50130
 Charleston, WV 25305-0130

Request for Quotation

RFQ NUMBER
PRI2674

PAGE
1

ADDRESS CORRESPONDENCE TO ATTENTION OF
BUYER 32 304-558-0492

RFQ COPY
 TYPE NAME/ADDRESS HERE

Bob Barker Company, Inc.
 134 N. Main Street
 P.O. Box 429
 Fuquay-Varina, NC 27526

WV PRISON INDUSTRIES

617 LEON SULLIVAN WAY
 CHARLESTON, WV
 25301 304-558-2945

DATE PRINTED	TERMS OF SALE	SHIP VIA	F.O.B.	FREIGHT TERMS
09/18/2006				

BID OPENING DATE: **10/11/2006** BID OPENING TIME **01:30PM**

LINE	QUANTITY	UDP	CAT NO	ITEM NUMBER	UNIT PRICE	AMOUNT
<p>REQUEST FOR QUOTATION</p> <p>THE PURCHASING DIVISION IS SOLICITING BIDS FOR THE HUTTONSVILLE CORRECTIONAL CENTER TO PROVIDE HEAVY DUTY STORAGE BOXES, TABLES, & CHAIRS PER THE ATTACHED SPECIFICATIONS.</p> <p>ATTACHMENTS:</p> <ol style="list-style-type: none"> 1. SPECIFICATIONS 2. BID FORM 3. AFFIDAVIT <p>THE SPECIFIED ITEMS MUST BE EQUAL TO THE NORIX BRAND AND MODEL NUMBERS DESCRIBED ON THE BID FORM. FOR OTHER BRANDS BID, LITERATURE (INCLUDING PICTURES), SHALL BE SUBMITTED SPECIFYING THE QUALITY, SIZES, ETC., TO DEMONSTRATE THE BRAND AND MODELS BID ARE EQUAL TO OR BETTER THAN THE SPECIFIED ITEMS.</p> <p>DELIVERY:</p> <p>THE COMPLETE ORDER MUST BE DELIVERED WITHIN 45 DAYS UPON RECEIPT OF THE PURCHASE ORDER. THE COST OF DELIVERY SHALL BE INCLUDED IN THE BID PRICE.</p>						
0001	1	LT		420-62-04-003		
STORAGE BOXES, TABLES, & CHAIRS						

SEE REVERSE SIDE FOR TERMS AND CONDITIONS

SIGNATURE	TELEPHONE	DATE
TITLE	FEIN	ADDRESS CHANGES TO BE NOTED ABOVE

WHEN RESPONDING TO RFQ, INSERT NAME AND ADDRESS IN SPACE ABOVE LABELED 'VENDOR'

**GENERAL TERMS & CONDITIONS
REQUEST FOR QUOTATION (RFQ) AND REQUEST FOR PROPOSAL (RFP)**

1. Awards will be made in the best interest of the State of West Virginia.
2. The State may accept or reject in part, or in whole, any bid.
3. All quotations are governed by the *West Virginia Code* and the *Legislative Rules* of the Purchasing Division.
4. Prior to any award, the apparent successful vendor must be properly registered with the Purchasing Division and have paid the required \$125.00 registration fee.
5. All services performed or goods delivered under State Purchase Orders/Contracts are to be continued for the term of the Purchase Order/Contract, contingent upon funds being appropriated by the Legislature or otherwise being made available. In the event funds are not appropriated or otherwise available for these services or goods, this Purchase Order/Contract becomes void and of no effect after June 30.
6. Payment may only be made after the delivery and acceptance of goods or services.
7. Interest may be paid for late payment in accordance with the *West Virginia Code*.
8. Vendor preference will be granted upon written request in accordance with the *West Virginia Code*.
9. The State of West Virginia is exempt from federal and state taxes and will not pay or reimburse such taxes.
10. The Director of Purchasing may cancel any Purchase Order/Contract upon 30 days written notice to the seller.
11. The laws of the State of West Virginia and the *Legislative Rules* of the Purchasing Division shall govern all rights and duties under the Contract, including without limitation the validity of this Purchase Order/Contract.
12. Any reference to automatic renewal is hereby deleted. The Contract may be renewed only upon mutual written agreement of the parties.
13. **BANKRUPTCY:** In the event the vendor/contractor files for bankruptcy protection, this contract is automatically null and void, and is terminated without further order.
14. **HIPAA Business Associate Addendum** - The West Virginia State Government HIPAA Business Associate Addendum (BAA), approved by the Attorney General, and available online at the Purchasing Division's web site (<http://www.state.wv.us/admin/purchase/vrc/hipaa.htm>) is hereby made part of the agreement. Provided that, the Agency meets the definition of a Covered Entity (45 CFR §160.103) and will be disclosing Protected Health Information (45 CFR §160.103) to the vendor.

INSTRUCTIONS TO BIDDERS

1. Use the quotation forms provided by the Purchasing Division.
2. **SPECIFICATIONS:** Items offered must be in compliance with the specifications. Any deviation from the specifications must be clearly indicated by the bidder. Alternates offered by the bidder as **EQUAL** to the specifications must be clearly defined. A bidder offering an alternate should attach complete specifications and literature to the bid. The Purchasing Division may waive minor deviations to specifications.
3. Complete all sections of the quotation form.
4. Unit prices shall prevail in cases of discrepancy.
5. All quotations are considered F.O.B. destination unless alternate shipping terms are clearly identified in the quotation.
6. **BID SUBMISSION:** All quotations must be delivered by the bidder to the office listed below prior to the date and time of the bid opening. Failure of the bidder to deliver the quotations on time will result in bid disqualifications.

SIGNED BID TO:

Department of Administration
Purchasing Division
2019 Washington Street East
Post Office Box 50130
Charleston, WV 25305-0130



State of West Virginia
 Department of Administration
 Purchasing Division
 2019 Washington Street East
 Post Office Box 50130
 Charleston, WV 25305-0130

Request for Quotation

RFQ NUMBER:
PRI2674

PAGE:
2

ADDRESS CORRESPONDENCE TO ATTENTION OF:
**BUYER 32
 304-558-0492**

RFQ COPY
 TYPE NAME/ADDRESS HERE

Bob Barker Company, Inc.
 134 N. Main Street
 P.O. Box 429
 Fuquay-Varina, NC 27526

WV PRISON INDUSTRIES
 617 LEON SULLIVAN WAY
 CHARLESTON, WV
 25301 304-558-2945

DATE PRINTED	TERMS OF SALE	SHIP VIA	FOB	FREIGHT TERMS
09/18/2006				

BID OPENING DATE: **10/11/2006** BID OPENING TIME **01:30PM**

LINE	QUANTITY	UOP	CAT NO	ITEM NUMBER	UNIT PRICE	AMOUNT
<p>VENDOR PREFERENCE CERTIFICATE</p> <p>CERTIFICATION AND APPLICATION* IS HEREBY MADE FOR PREFERENCE IN ACCORDANCE WITH WEST VIRGINIA CODE, 5A-3-37 (DOES NOT APPLY TO CONSTRUCTION CONTRACTS).</p> <p>A. APPLICATION IS MADE FOR 2.5% PREFERENCE FOR THE REASON CHECKED:</p> <p>() BIDDER IS AN INDIVIDUAL RESIDENT VENDOR AND HAS RESIDED CONTINUOUSLY IN WEST VIRGINIA FOR FOUR (4) YEARS IMMEDIATELY PRECEDING THE DATE OF THIS CERTIFICATION; OR</p> <p>() BIDDER IS A PARTNERSHIP, ASSOCIATION OR CORPORATION RESIDENT VENDOR AND HAS MAINTAINED ITS HEAD-QUARTERS OR PRINCIPAL PLACE OF BUSINESS CONTINUOUSLY IN WEST VIRGINIA FOR FOUR (4) YEARS IMMEDIATELY PRECEDING THE DATE OF THIS CERTIFICATION; OR 80% OF THE OWNERSHIP INTEREST OF BIDDER IS HELD BY ANOTHER INDIVIDUAL, PARTNERSHIP, ASSOCIATION OR CORPORATION RESIDENT VENDOR WHO HAS MAINTAINED ITS HEADQUARTERS OR PRINCIPAL PLACE OF BUSINESS CONTINUOUSLY IN WEST VIRGINIA FOR FOUR (4) YEARS IMMEDIATELY PRECEDING THE DATE OF THIS CERTIFICATION; OR</p> <p>() BIDDER IS A CORPORATION NONRESIDENT VENDOR WHICH HAS AN AFFILIATE OR SUBSIDIARY WHICH EMPLOYS A MINIMUM OF ONE HUNDRED STATE RESIDENTS AND WHICH HAS MAINTAINED ITS HEADQUARTERS OR PRINCIPAL PLACE OF BUSINESS WITHIN WEST VIRGINIA CONTINUOUSLY FOR THE FOUR (4) YEARS IMMEDIATELY PRECEDING THE DATE OF THIS CERTIFICATION.</p> <p>B. APPLICATION IS MADE FOR 2.5% PREFERENCE FOR THE REASON CHECKED:</p>						

SEE REVERSE SIDE FOR TERMS AND CONDITIONS

SIGNATURE	TELEPHONE	DATE
TITLE	FEIN	ADDRESS CHANGES TO BE NOTED ABOVE

WHEN RESPONDING TO RFQ, INSERT NAME AND ADDRESS IN SPACE ABOVE LABELED 'VENDOR'



State of West Virginia
 Department of Administration
 Purchasing Division
 2019 Washington Street East
 Post Office Box 50130
 Charleston, WV 25305-0130

**Request for
 Quotation**

RFQ NUMBER:
PRI2674

PAGE:
3

ADDRESS CORRESPONDENCE TO ATTENTION OF:
**BUYER 32
 304-558-0492**

RFQ COPY
 TYPE NAME/ADDRESS HERE

**Bob Barker Company, Inc.
 134 N. Main Street
 P.O. Box 429
 Fuquay-Varina, NC 27526**

WV PRISON INDUSTRIES

**617 LEON SULLIVAN WAY
 CHARLESTON, WV
 25301 304-558-2945**

DATE PRINTED	TERMS OF SALE	SHIP VIA	F.O.B.	FREIGHT TERMS
09/18/2006				

BID OPENING DATE: **10/11/2006** BID OPENING TIME **01:30PM**

LINE	QUANTITY	UOP	CAT NO	ITEM NUMBER	UNIT PRICE	AMOUNT
<p>() BIDDER IS A RESIDENT VENDOR WHO CERTIFIES THAT, DURING THE LIFE OF THE CONTRACT, ON AVERAGE AT LEAST 75% OF THE EMPLOYEES WORKING ON THE PROJECT BEING BID ARE RESIDENTS OF WEST VIRGINIA WHO HAVE RESIDED IN THE STATE CONTINUOUSLY FOR THE TWO YEARS IMMEDIATELY PRECEDING SUBMISSION OF THIS BID;</p> <p>OR</p> <p>() BIDDER IS A NONRESIDENT VENDOR EMPLOYING A MINIMUM OF ONE HUNDRED STATE RESIDENTS OR IS A NONRESIDENT VENDOR WITH AN AFFILIATE OR SUBSIDIARY WHICH MAINTAINS ITS HEADQUARTERS OR PRINCIPAL PLACE OF BUSINESS WITHIN WEST VIRGINIA EMPLOYING A MINIMUM OF ONE HUNDRED STATE RESIDENTS WHO CERTIFIES THAT, DURING THE LIFE OF THE CONTRACT, ON AVERAGE AT LEAST 75% OF THE EMPLOYEES OR BIDDERS' AFFILIATE'S OR SUBSIDIARY'S EMPLOYEES ARE RESIDENTS OF WEST VIRGINIA WHO HAVE RESIDED IN THE STATE CONTINUOUSLY FOR THE TWO YEARS IMMEDIATELY PRECEDING SUBMISSION OF THIS BID.</p> <p>BIDDER UNDERSTANDS IF THE SECRETARY OF TAX & REVENUE DETERMINES THAT A BIDDER RECEIVING PREFERENCE HAS FAILED TO CONTINUE TO MEET THE REQUIREMENTS FOR SUCH PREFERENCE, THE SECRETARY MAY ORDER THE DIRECTOR OF PURCHASING TO: (A) RESCIND THE CONTRACT OR PURCHASE ORDER ISSUED; OR (B) ASSESS A PENALTY AGAINST SUCH BIDDER IN AN AMOUNT NOT TO EXCEED 5% OF THE BID AMOUNT AND THAT SUCH PENALTY WILL BE PAID TO THE CONTRACTING AGENCY OR DEDUCTED FROM ANY UNPAID BALANCE ON THE CONTRACT OR PURCHASE ORDER.</p> <p>BY SUBMISSION OF THIS CERTIFICATE, BIDDER AGREES TO DISCLOSE ANY REASONABLY REQUESTED INFORMATION TO THE PURCHASING DIVISION AND AUTHORIZES THE DEPARTMENT OF TAX AND REVENUE TO DISCLOSE TO THE DIRECTOR OF PURCHASING APPROPRIATE INFORMATION VERIFYING THAT</p>						

SEE REVERSE SIDE FOR TERMS AND CONDITIONS

SIGNATURE	TELEPHONE	DATE
TITLE	FEIN	ADDRESS CHANGES TO BE NOTED ABOVE

WHEN RESPONDING TO RFQ, INSERT NAME AND ADDRESS IN SPACE ABOVE LABELED 'VENDOR'



State of West Virginia
 Department of Administration
 Purchasing Division
 2019 Washington Street East
 Post Office Box 50130
 Charleston, WV 25305-0130

Request for Quotation

RFQ NUMBER
PRI2674

PAGE
4

ADDRESS CORRESPONDENCE TO ATTENTION OF
**BUYER 32
 304-558-0492**

VENDOR

RFQ COPY
 TYPE NAME/ADDRESS HERE

**Bob Barker Company, Inc.
 134 N. Main Street
 P.O. Box 429
 Fuquay-Varina, NC 27526**

SHIP TO

**WV PRISON INDUSTRIES
 617 LEON SULLIVAN WAY
 CHARLESTON, WV
 25301 304-558-2945**

DATE PRINTED	TERMS OF SALE	SHIP VIA	F.O.B.	FREIGHT TERMS
09/18/2006				

BID OPENING DATE: **10/11/2006** BID OPENING TIME **01:30PM**

LINE	QUANTITY	UOP	CAT NO	ITEM NUMBER	UNIT PRICE	AMOUNT
<p>BIDDER HAS PAID THE REQUIRED BUSINESS TAXES, PROVIDED THAT SUCH INFORMATION DOES NOT CONTAIN THE AMOUNTS OF TAXES PAID NOR ANY OTHER INFORMATION DEEMED BY THE TAX COMMISSIONER TO BE CONFIDENTIAL.</p> <p>UNDER PENALTY OF LAW FOR FALSE SWEARING (WEST VIRGINIA CODE 61-5-3), BIDDER HEREBY CERTIFIES THAT THIS CERTIFICATE IS TRUE AND ACCURATE IN ALL RESPECTS; AND THAT IF A CONTRACT IS ISSUED TO BIDDER AND IF ANYTHING CONTAINED WITHIN THIS CERTIFICATE CHANGES DURING THE TERM OF THE CONTRACT, BIDDER WILL NOTIFY THE PURCHASING DIVISION IN WRITING IMMEDIATELY.</p> <p>BIDDER: <u>BOB BARKER CO</u></p> <p>DATE: <u>10/10/06</u></p> <p>SIGNED: <u>[Signature]</u></p> <p>TITLE: <u>BID ADMINISTRATOR</u></p> <p>* CHECK ANY COMBINATION OF PREFERENCE CONSIDERATION(S) IN EITHER "A" OR "B", OR BOTH "A" AND "B" WHICH YOU ARE ENTITLED TO RECEIVE. YOU MAY REQUEST UP TO THE MAXIMUM 5% PREFERENCE FOR BOTH "A" AND "B". (REV. 12/00)</p> <p>NOTICE</p> <p>A SIGNED BID MUST BE SUBMITTED TO:</p> <p>DEPARTMENT OF ADMINISTRATION PURCHASING DIVISION</p>						

SEE REVERSE SIDE FOR TERMS AND CONDITIONS

SIGNATURE	TELEPHONE	DATE
TITLE	FEIN	ADDRESS CHANGES TO BE NOTED ABOVE

WHEN RESPONDING TO RFQ, INSERT NAME AND ADDRESS IN SPACE ABOVE LABELED 'VENDOR'



State of West Virginia
 Department of Administration
 Purchasing Division
 2019 Washington Street East
 Post Office Box 50130
 Charleston, WV 25305-0130

Request for Quotation

RFQ NUMBER
PRI2674

PAGE
5

ADDRESS CORRESPONDENCE TO ATTENTION OF
BUYER 32
304-558-0492

VENDOR

RFQ COPY
 TYPE NAME/ADDRESS HERE

Bob Barker Company, inc.
134 N. Main Street
P.O. Box 429
Fuquay-Varina, NC 27526

SHIP TO

WV PRISON INDUSTRIES
617 LEON SULLIVAN WAY
CHARLESTON, WV
25301 304-558-2945

DATE PRINTED	TERMS OF SALE	SHIP VIA	FOB	FREIGHT TERMS
09/18/2006				

BID OPENING DATE: **10/11/2006** BID OPENING TIME **01:30PM**

LINE	QUANTITY	UOF	CAT NO	ITEM NUMBER	UNIT PRICE	AMOUNT
<p>BUILDING 15 2019 WASHINGTON STREET, EAST CHARLESTON, WV 25305-0130</p> <p>THE BID SHOULD CONTAIN THIS INFORMATION ON THE FACE OF THE ENVELOPE OR THE BID MAY NOT BE CONSIDERED:</p> <p>SEALED BID</p> <p>BUYER: RON PRICE</p> <p>RFQ. NO.: PRI2674</p> <p>BID OPENING DATE: OCTOBER 11, 2006</p> <p>BID OPENING TIME: 1:30 PM</p> <p>PLEASE PROVIDE A FAX NUMBER IN CASE IT IS NECESSARY TO CONTACT YOU REGARDING YOUR BID: 800 322 7537</p> <p>CONTACT PERSON (PLEASE PRINT CLEARLY): MARIE PATTERSON</p>						

SEE REVERSE SIDE FOR TERMS AND CONDITIONS

SIGNATURE	TELEPHONE	DATE
TITLE	FEIN	ADDRESS CHANGES TO BE NOTED ABOVE

WHEN RESPONDING TO RFQ, INSERT NAME AND ADDRESS IN SPACE ABOVE LABELED 'VENDOR'

PRI2674 - (REVISED) BID FORM - STORAGE BOXES, TABLES, & CHAIRS - BID OPENING DATE: 10/11/2006, 1:30 PM

Item#	Description	Brand & Model # or Equal	Unit Bid Price	Estimated Usage	Extended Bid Price
1	Tank Storage Box	NORIX / PB200	\$	480	\$ —
2	Tank Storage Box Lids	NORIX / PBL400	\$	480	\$ —
3	Tank Storage Box	NORIX / PB350 XL	\$	20	\$ —
4	Tank Storage Box Lids	NORIX / PB402	\$	20	\$ —
5	Slammer Tables Laminate Game Top	NORIX / XB4242GT	\$	40	\$ 17680.00
6	Slammer Tables Pearl Sand Lam. Top	NORIX / XB4242PT	\$	88	\$ 35024.00
7	Integra Armless Chairs - Buff	NORIX / C110	\$	78	\$ —
8	Integra Armless Chairs - Plum	NORIX / C110	\$	78	\$ —
9	Integra Armless Chairs - Teal	NORIX / C110	\$	95	\$ —
10	Integra Armless Chairs - Fog Grey	NORIX / C110	\$	95	\$ —
11	Integra Armless Chairs - Blue Grey	NORIX / C110	\$	95	\$ —
12	Integra Armless Chairs - Slate Blue	NORIX / C110	\$	95	\$ —
13	Integra Armless Chairs - Buff	NORIX / C110	\$	212	\$ —
14	Integra Arm Chairs - Buff	NORIX / C120	\$	44	\$ 1969.00
15	Mega-Max Seats - Teal	NORIX / C170	\$	11	\$ —
16	Mega-Max Seats - Buff	NORIX / C170	\$	10	\$ —
17	42X42 Sq. Leg Table w/Game Top - Black Slammer Stone Edge	NORIX / LB4242GT	\$	60	\$ —
				Total	\$ 54673.00

Bidder Information:

Name: Bob Barker Company, Inc.
134 N. Main Street
 Company name: P.O. Box 429
 Address: Fuquay-Varina, NC 27526
 Phone#: 800 334 9880
 Fax#: 800 322 7537
 Email Address: mariepatterson@bobbarker.com



State of West Virginia
 Department of Administration
 Purchasing Division
 2019 Washington Street East
 Post Office Box 50130
 Charleston, WV 25305-0130

Request for Quotation

RFQ NUMBER
PRI2674

PAGE
6

ADDRESS CORRESPONDENCE TO ATTENTION OF
**BUYER 32
 304-558-0492**

RFQ COPY
 TYPE NAME/ADDRESS HERE

**Bob Barker Company, Inc.
 134 N. Main Street
 P.O. Box 429
 Fuquay-Varina, NC 27526**

SHIP TO
WV PRISON INDUSTRIES

**617 LEON SULLIVAN WAY
 CHARLESTON, WV
 25301 304-558-2945**

DATE PRINTED	TERMS OF SALE	SHIP VIA	F.O.B.	FREIGHT TERMS
09/18/2006				

BID OPENING DATE: **10/11/2006** BID OPENING TIME **01:30PM**

LINE	QUANTITY	UOP	CAT NO	ITEM NUMBER	UNIT PRICE	AMOUNT
***** THIS IS THE END OF RFQ PRI2674 ***** TOTAL:						<u>54673.00</u>

SEE REVERSE SIDE FOR TERMS AND CONDITIONS

SIGNATURE	TELEPHONE	DATE
TITLE	FEIN	ADDRESS CHANGES TO BE NOTED ABOVE

WHEN RESPONDING TO RFQ, INSERT NAME AND ADDRESS IN SPACE ABOVE LABELED 'VENDOR'

Property Box (a.k.a. Tank Box)

Property storage boxes for inmate records and/or personal possessions. Designed and engineered for institutional durability. Suitable for continuous daily use in a correctional environment.

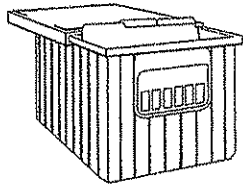

Model #: PB150 (Legal/Letter)

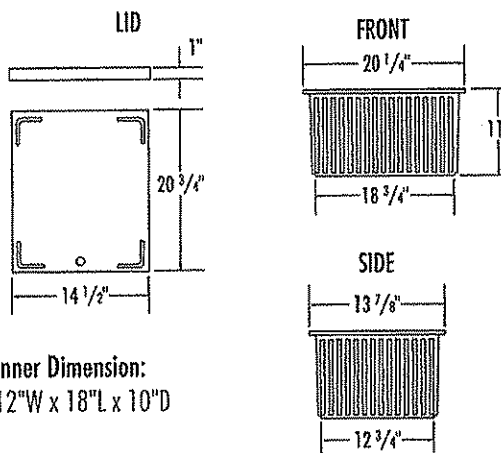

Inner Dimension:
12"W x 18"L x 10"D

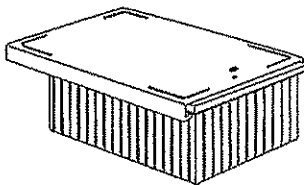

Model #: PB200 (Standard)

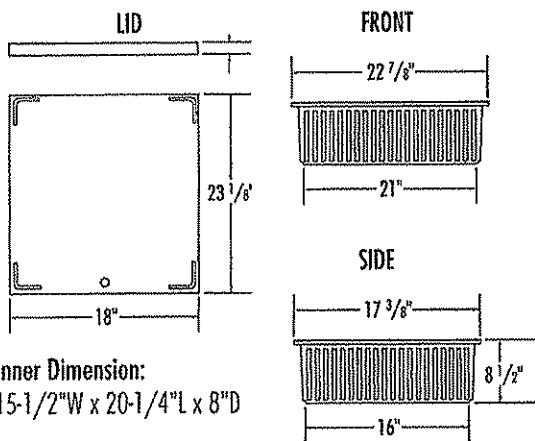

Inner Dimension:
15-1/2"W x 20-1/4"L x 8"D

Fabrication:

Full height molded-in vertical ribs every 1-1/4". 1/2" x 7/8" top flange provides maximum strength and rigidity. Capable of nesting for stable stacking.

Material:

Injection molded from structural polyethylene. 100% recyclable.

Flammability:

Certified to pass the following flammability standards:

- State of California, Technical Bulletin No. 133, Flammability Test Procedure for Seating Furniture for Use in Public Occupancies.

Quality & Testing Standards, conforms to:

- Minimum sustained static load of 3000 lbs. for four hours.

Color:

Grey.

Weight:

Box:

- PB150 (Legal/Letter): 9.5 lbs.
- PB200 (Standard): 9 lbs.
- PB300 (Large): 12 lbs.
- PB350 (Extra Large): 22.5 lbs.

Lid:

- PBL401: 3.5 lbs.
- PBL400: 4 lbs.
- PBL400: 4 lbs.
- PBL402: 8 lbs.

Options:

Sliding lid. Padlock. Under bunk rail sets.

Assembly:

None required.

Installation:

None required.

Warranty:

2 year limited replacement warranty.

Maintenance:

Easily cleaned with a damp cloth and mild soap solution.

Filing System:

- 12600 Institutional Furniture
- 11197 Correctional Furniture

SPECIFICATIONS

Continued on back.

Property Box (a.k.a. Tank Box)

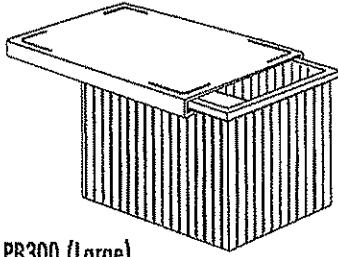

Model #: PB300 (Large)

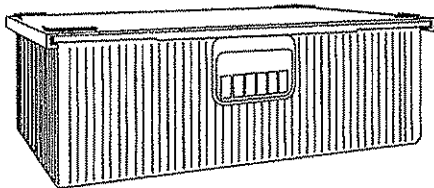
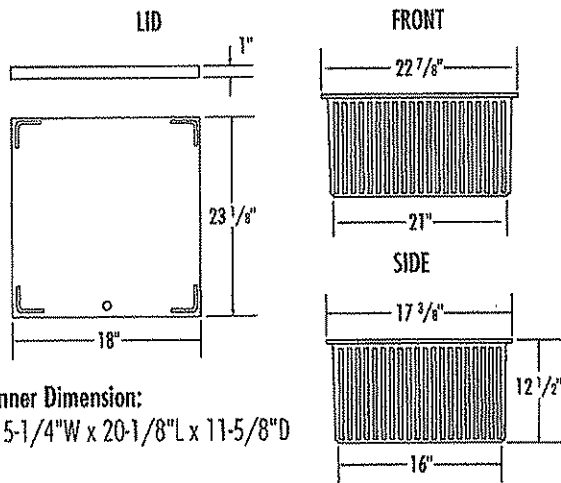

Model #: PB350 (Extra Large)

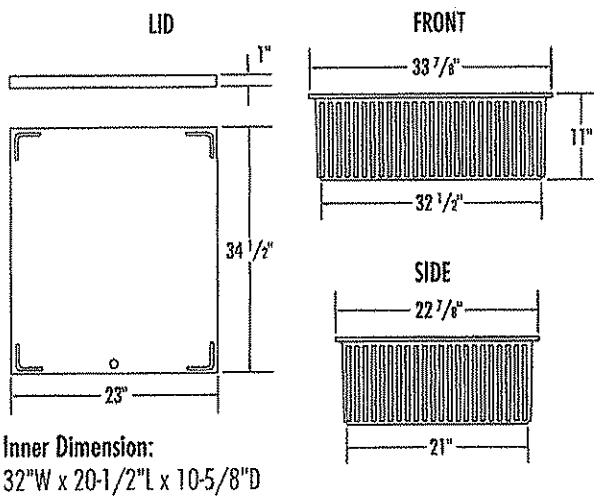

SPECIFICATIONS

Armless Chair

Multi-use stackable armless chair. Engineered and proven suitable for continuous daily use in an institutional environment. (Note: For safety reasons, chairs with open backs or arms, patio style, or residential quality chairs should not be used for this requirement). Compatible style, color, construction, material, functionality and durability with arm chairs, lounge chairs and tables provided by Norix.

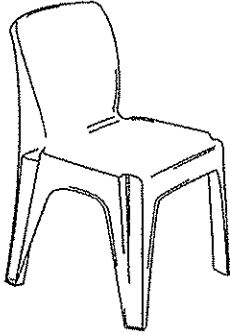

Model #: C110

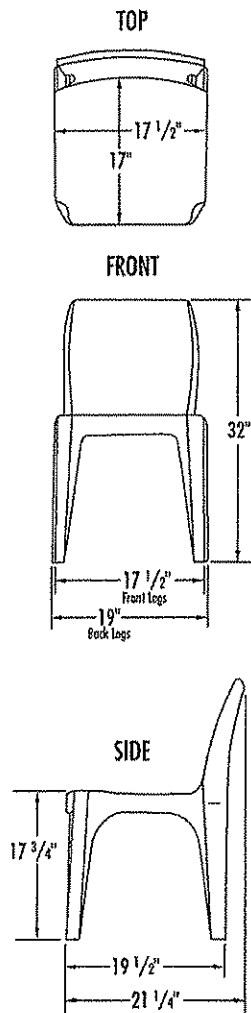

Fabrication:

One-piece injection molded, without steel or wood components. 1-1/2" deep "X" rib on the underside of the seat, connecting legs diagonally for superior strength. Honeycomb reinforcing rib cells.

Material:

High impact grade copolymer polypropylene with FRPP5 Fire Retardant. Chemically resistant to acetone, alcohol, blood, vinegar, urine, feces, salt solution and chlorine solution.

Flammability:

Certified to pass the following flammability standards:

- State of California, Technical Bulletin No. 133, Flammability Test Procedure for Seating Furniture for Use in Public Occupancies.
- Federal Aviation Administration Test 25.853 A & B, Appendix F, Part 1, 60 second gas burner ignition, material self-extinguishing & 12 second gas burner ignition, material self-extinguishing. (Note: Flammability tests reflect standardized laboratory test procedures and may not reflect results in actual fire conditions).

Quality & Testing Standards, conforms to:

- ISO 9001-1987: Quality certified manufacturer.
- ASTM F1561-94, Parts A & B: Standard Performance Test for Plastic Chairs.
- Furniture Industry Research Association: Grade 5 - Severe Contract Applications, 200,000+ cycles.

Color:

Buff, Fog Grey, Blue Grey, Plum, Teal, Slate Blue.

Stacking:

15 chairs in 83".

Weight:

7.1 lbs.

Options:

3 wheel dolly.

Assembly:

None required.

Installation:

None required.

Warranty:

2 year limited replacement warranty.

Maintenance:

Easily cleaned with a damp cloth and a mild soap solution.

Filing System:

12600 Institutional Furniture
11197 Correctional Furniture

SPECIFICATIONS

Slammer Table

Heavy duty durable, tamper-resistant "X" base style. Engineered and suitable for continuous use in an institutional or correctional environment.

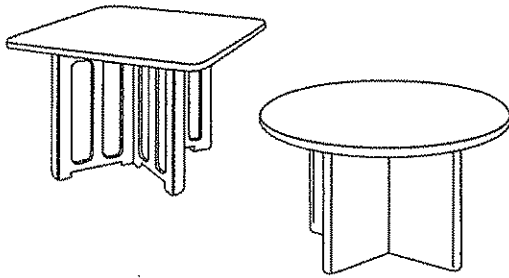

- Model #: XB3636PT (36"x36")
 XB3636GT (36"x36" Game Top)
 XB4242PT (42"x42")
 XB4242GT (42"x42" Game Top)
 XB3600PT (36" dia.)
 XXB3600GT (36" dia. Game Top)
 XB4200PT (42" dia.)
 XB4200GT (42" dia. Game Top)
 XB4800PT (48" dia.)
 XB4800GT (48" dia. Game Top)

TOP

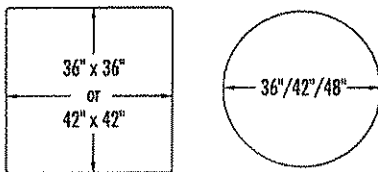

FRONT

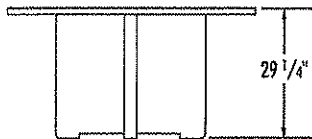

Fabrication:

Base: Two interlocking base panels.

Top: Selected material permanently bonded to a core of 45 lb. density particle board with embedded T-nuts for securing top to base.

Material:

Laminate Base Panels: 1-1/8" thick 45 lb. density particle board, sandwiched between 1/8" thick hardboard and faced both sides with .050" thick high pressure laminate and banded on three exposed edges with heavy duty T-molding that is glued and steel pinned every four inches. An intermediate mounting plate joins the base to the top.

Rotationally Molding Base: Specially formulated fire retardant high impact polyethylene with ultraviolet light stabilizers (to reduce fading). Openings sealed by the top allow the base to be weighted on-site with clean, dry sand (not included).

Laminate Top: Decorative high pressure laminate sealed with a specially formulated highly durable Slammer Stone edge. Edge is radiused for safety and pressure fused to the top rendering it permanently non-removable and highly sanitary. 1-1/2" thick edge profile.

Nu-Stone® Top: Specially formulated fiberglass filled polyester composite, compression molded under 2,000 p.s.i. pressure to create a seamless, one-piece top and edge surface for superior impact resistance and durability. 1-1/2" thick edge profile (42" round and square only).

Stainless Steel Quietcore® Top: Durable 18 gauge stainless steel top surface wrapped around sound deadening particle board core. 1-1/4" edge profile (42" round only).

Color:

Base: Black Slate Laminate or Black Polyethylene.

Laminate Top: Wilsonart Pearl Sand #4604-60 with black Slammer Stone edge.

Nu-Stone® Top: GraniteStone or PebbleStone.

Stainless Steel Top: #4 finish.

Weight:

Varies on model. Contact manufacturer.

Options:

1-1/4" thick laminate top with black vinyl T-mold edge.

Game tops (GT): Checkerboard available on Nu-Stone® and Stainless Steel tops. Checkerboard / backgammon / solitaire available on laminate tops.

Assembly:

Assembly required

Installation:

Refer to manufacturer's instructions for securing top to base.

Warranty:

2 year limited replacement warranty.

Maintenance:

Easily cleaned with a damp cloth.

Filing System:

12600 Institutional Furniture

11197 Correctional Furniture

SPECIFICATIONS

AFFIDAVIT

West Virginia Code §5A-3-10a states:

No contract or renewal of any contract may be awarded by the state or any of its political subdivisions to any vendor or prospective vendor when the vendor or prospective vendor or a related party to the vendor or prospective vendor is a debtor and the debt owned is an amount greater than one thousand dollars in the aggregate.

DEFINITIONS:

"Debt" means any assessment, premium, penalty, fine, tax or other amount of money owed to the state or any of its political subdivisions because of a judgment, fine, permit violation, license assessment, defaulted workers' compensation premium, penalty or other assessment presently delinquent or due and required to be paid to the state or any of its political subdivisions, including any interest or additional penalties accrued thereon.

"Debtor" means any individual, corporation, partnership, association, limited liability company or any other form or business association owing a debt to the state or any of its political subdivisions.

"Political subdivision" means any county commission; municipality; county board of education; any instrumentality established by a county or municipality; any separate corporation or instrumentality established by one or more counties or municipalities, as permitted by law; or any public body charged by law with the performance of a government function or whose jurisdiction is coextensive with one or more counties or municipalities.

"Related party" means a party, whether an individual, corporation, partnership, association, limited liability company or any other form or business association or other entity whatsoever, related to any vendor by blood, marriage, ownership or contract through which the party has a relationship of ownership or other interest with the vendor so that the party will actually or by effect receive or control a portion of the benefit, profit or other consideration from performance of a vendor contract with the party receiving an amount that meets or exceeds five percent of the total contract amount.

EXCEPTION:

The prohibition of this section does not apply where a vendor has contested any tax administered pursuant to chapter eleven of this code, workers' compensation premium, permit fee or environmental fee or assessment and the matter has not become final or where the vendor has entered into a payment plan or agreement and the vendor is not in default of any of the provisions of such plan or agreement.

LICENSING:

The vendor must be licensed in accordance with any and all state requirements to do business with the state of West Virginia.

CONFIDENTIALITY:

The vendor agrees that he or she will not disclose to anyone, directly or indirectly, any such personally identifiable information or other confidential information gained from the agency, unless the individual who is the subject of the information consents to the disclosure in writing or the disclosure is made pursuant to the agency's policies, procedures and rules. Vendors should visit www.state.wv.us/admin/purchase/privacy for the Notice of Agency Confidentiality Policies.

Under penalty of law for false swearing (West Virginia Code, §61-5-3), it is hereby certified that the vendor acknowledges the information in this said affidavit and are in compliance with the requirements as stated.

Vendor's Name: BOB BARKER CO

Authorized Signature:  Date: 10/10/04

**GENERAL TERMS & CONDITIONS
REQUEST FOR QUOTATION (RFQ) AND REQUEST FOR PROPOSAL (RFP)**

1. Awards will be made in the best interest of the State of West Virginia.
2. The State may accept or reject in part, or in whole, any bid.
3. All quotations are governed by the *West Virginia Code* and the *Legislative Rules* of the Purchasing Division.
4. Prior to any award, the apparent successful vendor must be properly registered with the Purchasing Division and have paid the required \$125.00 registration fee.
5. All services performed or goods delivered under State Purchase Orders/Contracts are to be continued for the term of the Purchase Order/Contract, contingent upon funds being appropriated by the Legislature or otherwise being made available. In the event funds are not appropriated or otherwise available for these services or goods, this Purchase Order/Contract becomes void and of no effect after June 30.
6. Payment may only be made after the delivery and acceptance of goods or services.
7. Interest may be paid for late payment in accordance with the *West Virginia Code*.
8. Vendor preference will be granted upon written request in accordance with the *West Virginia Code*.
9. The State of West Virginia is exempt from federal and state taxes and will not pay or reimburse such taxes.
10. The Director of Purchasing may cancel any Purchase Order/Contract upon 30 days written notice to the seller.
11. The laws of the State of West Virginia and the *Legislative Rules* of the Purchasing Division shall govern all rights and duties under the Contract, including without limitation the validity of this Purchase Order/Contract.
12. Any reference to automatic renewal is hereby deleted. The Contract may be renewed only upon mutual written agreement of the parties.
13. **BANKRUPTCY:** In the event the vendor/contractor files for bankruptcy protection, this contract is automatically null and void, and is terminated without further order.
14. **HIPAA Business Associate Addendum -** The West Virginia State Government HIPAA Business Associate Addendum (BAA), approved by the Attorney General, and available online at the Purchasing Division's web site (<http://www.state.wv.us/admin/purchase/vrc/hipaa.htm>) is hereby made part of the agreement. Provided that, the Agency meets the definition of a Covered Entity (45 CFR §160.103) and will be disclosing Protected Health Information (45 CFR §160.103) to the vendor.

INSTRUCTIONS TO BIDDERS

1. Use the quotation forms provided by the Purchasing Division.
2. **SPECIFICATIONS:** Items offered must be in compliance with the specifications. Any deviation from the specifications must be clearly indicated by the bidder. Alternates offered by the bidder as **EQUAL** to the specifications must be clearly defined. A bidder offering an alternate should attach complete specifications and literature to the bid. The Purchasing Division may waive minor deviations to specifications.
3. Complete all sections of the quotation form.
4. Unit prices shall prevail in cases of discrepancy.
5. All quotations are considered F.O.B. destination unless alternate shipping terms are clearly identified in the quotation.
6. **BID SUBMISSION:** All quotations must be delivered by the bidder to the office listed below prior to the date and time of the bid opening. Failure of the bidder to deliver the quotations on time will result in bid disqualifications.

SIGNED BID TO:

Department of Administration
Purchasing Division
2019 Washington Street East
Post Office Box 50130
Charleston, WV 25305-0130



State of West Virginia
 Department of Administration
 Purchasing Division
 2019 Washington Street East
 Post Office Box 50130
 Charleston, WV 25305-0130

Request for Quotation

RFQ NUMBER
PRI2674

PAGE
1

ADDRESS CORRESPONDENCE TO ATTENTION OF:
**BUYER 32
 304-558-0492**

VENDOR

RFQ COPY
 TYPE NAME/ADDRESS HERE

SHIP TO

WV PRISON INDUSTRIES

**617 LEON SULLIVAN WAY
 CHARLESTON, WV
 25301 304-558-2945**

DATE PRINTED	TERMS OF SALE	SHIP VIA	F.O.B.	FREIGHT TERMS
09/21/2006				
BID OPENING DATE: 10/11/2006		BID OPENING TIME 01:30PM		

LINE	QUANTITY	UOP	CAT. NO.	ITEM NUMBER	UNIT PRICE	AMOUNT
ADDENDUM# 01						
THIS ADDENDUM IS ISSUED TO ADD TO THE ORIGINAL QUANTITY, MODEL NUMBERS, & LOCATION OF DELIVERY.						
CLERIFICATION: DELIVERY OF ITEMS 1-12 SHALL BE DELIVERED TO THE HUTTONSVILLE CORRECTIONAL CENTER STATE RT. HIGHWAY 250, HUTTONSVILLE, WV 26273. ITEM NUMBERS 13 THROUGH 17 WILL BE DELIVERED TO THE LAKIN CORRECTIONAL CENTER, 11264 OHIO RIVER ROAD, WEST COLUMBIA, WV 25287.						
ATTACHMENTS:						
<ol style="list-style-type: none"> 1. REVISED BID FORM 2. ADDENDUM ACKNOWLEDGEMENT 						

SEE REVERSE SIDE FOR TERMS AND CONDITIONS

SIGNATURE	TELEPHONE	DATE
TITLE	FEIN	ADDRESS CHANGES TO BE NOTED ABOVE

WHEN RESPONDING TO RFQ, INSERT NAME AND ADDRESS IN SPACE ABOVE LABELED 'VENDOR'

Vendor:	Spending Unit:
---------	----------------

Requisition No.: DR12674

ADDENDUM ACKNOWLEDGEMENT

I hereby acknowledge receipt of the following checked addendum(s) and have made the necessary revisions to my proposal, plans and/or specifications, etc.

Addendum No.'s:

- No. 1 ✓ mp
- No. 2 _____
- No. 3 _____
- No. 4 _____
- No. 5 _____

I understand that failure to confirm the receipt of the addendum(s) is cause for rejection of bids.

Bob Barker
Signature
BOB BARKER CO
Company
10/10/04
Date

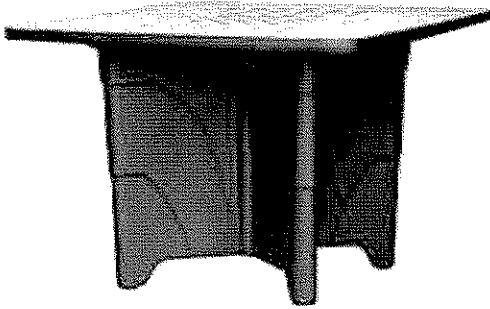
ModuMaxx X-Base Molded Tables

- Fire-retardant, high-impact polyethylene construction is resistant to heavy-duty impact.
- One-piece, hollow base can be weighted, on-site, with sand or ballast material for added stability.
- Table tops are 45 lb. density particleboard, sandwiched between a laminate top and a balance sheet bottom for additional structural strength.
- Black bases, Spektrum laminate tops with black vinyl bumper edges.
- All units are shipped unassembled with hardware and assembly instructions included.
- Please allow eight weeks for delivery.

Item Number	Description
Z536S-GLM	Game Top, 36" X 36" X 29 1/2"
Z536S-SLM	Plain Top, 36" X 36" X 29 1/2"
Z542S-GLM	Game Top, 42" X 42" X 29 1/2"
Z542S-SLM	Plain Top, 42" X 42" X 29 1/2"

ITEMS # 5 AND 6

ITEM #14

specs (800x1035x16M bmp)

MODU flexibility in furniture
FORM

DATA AND SPECIFICATIONS

**ModaMaxx™ 5000 Series
5000-20 Stacking/Arm Chair**

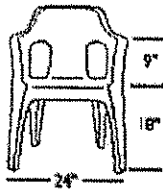

Stacking Chair
Front view 5000-20

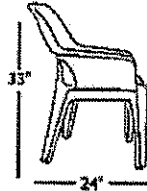

Stacking Chair
Side View



Stacking Chair
Seat View

ModaForm stacking chairs are engineered for institutional durability and suitable for continuous use in demanding, active environments. Chairs can be ganged.

SEATING TYPES

- Styles:
- Stacking Chair - Chair shall be capable of stacking up to 20 high.
 - Stacking Chair with Pads - Chair shall be capable of stacking up to 10 high.

STACKING CHAIR

Dimensions:

The chair seat and back shall be wider and the armrest higher than other chairs of this type for maximum comfort: 24" W x 24" D x 33" H x 18" SH
Chairs less than this size shall not be acceptable.

Weights

10.4 lbs.

Materials:

High-impact grade copolymer polypropylene with UV light stabilizers prevents fading and anti-static additive reduces dust attraction. Pigmented color is homogeneous throughout the entire material rather than a surface skin of color.
Colors Available in four colors to meet aesthetic considerations: can be color coordinated with other ModaForm products.
Standard: #700 - Sandstream, # 311 - Blush, # 426 - Slate blue, and # 507 - Aqua grey
Finish: Matte/suede (non-gloss), easy to clean.

Construction:

- One-piece injection molded construction without steel or wood components of any kind.
- 36 interlocking reinforcing rib cells on the underside of the seat and five points of reinforcement at rear legs for maximum strength.
 - Bowed ribs to add to the strength of the chair back.
 - Chair feet are at double angles to reduce stress and maintain stability when in a rocked-back position.

Flammability:

Meets the State of California Technical Bulletin 133 flammability seat requirements. Test results conducted by a recognized independent laboratory are available.

Passes tests:

ASTM F1561-94 standard performance requirements for plastic chairs for outdoor use.
• Class A - Residential • Class B - Non-residential.
ANSI-BIFMA - ANSI5.1-1993 for General-Purpose office chairs.
Test results conducted by a recognized independent laboratory are available.

Chemical Resistance:

Chlorine solution, acetone, blood, urine, feces, wine, whiskey, beer, vinegar, salt solution.

Cleaning:

Chairs can be easily cleaned with a damp cloth and mild detergent. Steam cleaning does not harm the product. Can be sanitized with bleach-based cleaners to aid in the control of infections and bloodborne pathogens.

Accessories:

- Chair stacking dolly for stack mobility
- Mechanical clip fastener for ganging



On April 28, 2006, Bob Barker Company and Leslee Scott, Inc. became affiliated and are now under common ownership. We are excited about our new relationship because it will enable us to offer a wider range of product lines and choices and even better service to our customers. For the present, both companies will continue to operate through their existing sales and support organizations, and customers can continue to deal with either or both of the companies as they prefer. As we work to integrate our operations there may be occasions when we will determine that our best service to a customer can be achieved by handling an account through only one company or the other or sometimes by sharing an account between the two companies. We will conduct all our activities in full compliance with laws governing competitively bid contracts and also in full compliance with applicable federal and state laws that protect and promote a healthy competitive marketplace. If you have any questions about our new relationship, please feel free to call **Marie Patterson** at **1-800-235-8586 ext 431**. We hope you are as excited as we are about this new milestone in our two companies' histories.