



State of West Virginia
 Department of Administration
 Purchasing Division
 2019 Washington Street East
 Post Office Box 50130
 Charleston, WV 25305-0130

Request for Quotation

RFQ NUMBER
 LSH70143

PAGE
 1

ADDRESS CORRESPONDENCE TO ATTENTION OF:
 ROBERTA WAGNER
 304-558-0067

VENDOR

|||||
 Douglas Equipment
 301 North Street
 Bluefield, WV 24701

SHIP TO

HEALTH AND HUMAN RESOURCES
 LAKIN HOSPITAL

 1 BATEMAN CIRCLE
 LAKIN, WV
 25287 304-675-0860

DATE PRINTED 12/19/2006	TERMS OF SALE	SHIP VIA	F.O.B.	FREIGHT TERMS
BID OPENING DATE: 02/01/2007		BID OPENING TIME 01:30PM		

LINE	QUANTITY	UOP	CAT. NO.	ITEM NUMBER	UNIT PRICE	AMOUNT
0001	1	EA		165-29	\$48,444.00	\$48,444.00
DISHWASHERS (COMMERCIAL) REQUEST FOR QUOTATION TO PROVIDE AND INSTALL A HOBART MODEL CRS66A DISHWASHER "OR EQUAL" AS SPECIFIED AND LISTED HEREIN FOR LAKIN HOSPITAL LOCATED AT #1 BATEMAN CIRCLE, LAKIN, WEST VIRGINIA, 25287. <BID INCLUDES ALTERNATE> THE MODEL/BRAND/SPECIFICATIONS NAMED HEREIN ESTABLISH THE ACCEPTABLE LEVEL OF QUALITY ONLY AND ARE NOT INTENDED TO REFLECT A PREFERENCE OR FAVOR ANY PARTICULAR BRAND OR VENDOR. VENDORS WHO ARE BIDDING ALTERNATES SHOULD SO STATE AND INCLUDE PERTINENT LITERATURE AND SPECIFICATIONS. FAILURE TO PROVIDE INFORMATION FOR ANY ALTERNATES MAY BE GROUNDS FOR REJECTION OF THE BID. THE STATE RESERVES THE RIGHT TO WAIVE MINOR IRREGULARITIES IN BIDS OR SPECIFICATIONS IN ACCORDANCE WITH SECTION 148-1-4(F) OF THE WEST VIRGINIA LEGISLATIVE RULES AND REGULATIONS. BID BOND REQUIRED ***** MANDATORY PRE-BID MEETING..... 01/10/2007 VENDOR'S WRITTEN QUESTIONS SUBMISSION DEADLINE (CLOSE OF BUSINESS)..... 01/17/2007 RESPONSE TO QUESTIONS/ADDENDUM ISSUED..... 01/18/2007 BID OPENING DATE..... 02/01/2007 ***** EXHIBIT 5						

RECEIVED
 2007 FEB -5 A 10:28
 PURCHASING DIVISION
 STATE OF WV

SEE REVERSE SIDE FOR TERMS AND CONDITIONS

SIGNATURE: *Ray Ellison* TELEPHONE: (800) 962-8618 DATE: 2-1-2007

TITLE: Bid Specialist FEIN: 550585890 ADDRESS CHANGES TO BE NOTED ABOVE

WHEN RESPONDING TO RFQ, INSERT NAME AND ADDRESS IN SPACE ABOVE LABELED 'VENDOR'

**GENERAL TERMS & CONDITIONS
REQUEST FOR QUOTATION (RFQ) AND REQUEST FOR PROPOSAL (RFP)**

1. Awards will be made in the best interest of the State of West Virginia.
2. The State may accept or reject in part, or in whole, any bid.
3. All quotations are governed by the *West Virginia Code* and the *Legislative Rules* of the Purchasing Division.
4. Prior to any award, the apparent successful vendor must be properly registered with the Purchasing Division and have paid the required \$125.00 registration fee.
5. All services performed or goods delivered under State Purchase Orders/Contracts are to be continued for the term of the Purchase Order/Contract, contingent upon funds being appropriated by the Legislature or otherwise being made available. In the event funds are not appropriated or otherwise available for these services or goods, this Purchase Order/Contract becomes void and of no effect after June 30.
6. Payment may only be made after the delivery and acceptance of goods or services.
7. Interest may be paid for late payment in accordance with the *West Virginia Code*.
8. Vendor preference will be granted upon written request in accordance with the *West Virginia Code*.
9. The State of West Virginia is exempt from federal and state taxes and will not pay or reimburse such taxes.
10. The Director of Purchasing may cancel any Purchase Order/Contract upon 30 days written notice to the seller.
11. The laws of the State of West Virginia and the *Legislative Rules* of the Purchasing Division shall govern all rights and duties under the Contract, including without limitation the validity of this Purchase Order/Contract.
12. Any reference to automatic renewal is hereby deleted. The Contract may be renewed only upon mutual written agreement of the parties.
13. **BANKRUPTCY:** In the event the vendor/contractor files for bankruptcy protection, this contract is automatically null and void, and is terminated without further order.
14. **HIPAA Business Associate Addendum -** The West Virginia State Government HIPAA Business Associate Addendum (BAA), approved by the Attorney General, and available online at the Purchasing Division's web site (<http://www.state.wv.us/admin/purchase/vrc/hipaa.htm>) is hereby made part of the agreement. Provided that, the Agency meets the definition of a Covered Entity (45 CFR §160.103) and will be disclosing Protected Health Information (45 CFR §160.103) to the vendor.

INSTRUCTIONS TO BIDDERS

1. Use the quotation forms provided by the Purchasing Division.
2. **SPECIFICATIONS:** Items offered must be in compliance with the specifications. Any deviation from the specifications must be clearly indicated by the bidder. Alternates offered by the bidder as **EQUAL** to the specifications must be clearly defined. A bidder offering an alternate should attach complete specifications and literature to the bid. The Purchasing Division may waive minor deviations to specifications.
3. Complete all sections of the quotation form.
4. Unit prices shall prevail in cases of discrepancy.
5. All quotations are considered F.O.B. destination unless alternate shipping terms are clearly identified in the quotation.
6. **BID SUBMISSION:** All quotations must be delivered by the bidder to the office listed below prior to the date and time of the bid opening. Failure of the bidder to deliver the quotations on time will result in bid disqualifications.

SIGNED BID TO:

Department of Administration
Purchasing Division
2019 Washington Street East
Post Office Box 50130
Charleston, WV 25305-0130



State of West Virginia
 Department of Administration
 Purchasing Division
 2019 Washington Street East
 Post Office Box 50130
 Charleston, WV 25305-0130

Request for Quotation

RFQ NUMBER
LSH70143

PAGE
2

ADDRESS CORRESPONDENCE TO ATTENTION OF:
ROBERTA WAGNER 304-558-0067

RFQ COPY
 TYPE NAME/ADDRESS HERE

VENDOR

Douglas Equipment
 301 North Street
 Bluefield, WV 24701
 (304) 327-0149 1-(800) 962-8618

SHIP TO

HEALTH AND HUMAN RESOURCES
 LAKIN HOSPITAL
 1 BATEMAN CIRCLE
 LAKIN, WV
 25287 304-675-0860

DATE PRINTED 12/19/2006	TERMS OF SALE	SHIP VIA	F.O.B.	FREIGHT TERMS
----------------------------	---------------	----------	--------	---------------

BID OPENING DATE: 02/01/2007 BID OPENING TIME 01:30PM

LINE	QUANTITY	UOP	CAT NO.	ITEM NUMBER	UNIT PRICE	AMOUNT
<p>NOTICE TO PROCEED: THIS CONTRACT IS TO BE PERFORMED WITHIN 90 CALENDAR DAYS AFTER THE NOTICE TO PROCEED IS RECEIVED. UNLESS OTHERWISE SPECIFIED, ALL WORK SHALL BE COMPLETE WITHIN 90 CALENDAR DAYS FROM THE APPROVAL OF THE SHOP DRAWINGS</p> <p>CANCELLATION: THE DIRECTOR OF PURCHASING RESERVES THE RIGHT TO CANCEL THIS CONTRACT IMMEDIATELY UPON WRITTEN NOTICE TO THE VENDOR IF THE MATERIALS OR WORKMANSHIP SUPPLIED ARE OF AN INFERIOR QUALITY OR DO NOT CONFORM WITH THE SPECIFICATIONS OF THE BID AND CONTRACT HERE IN.</p> <p>WAGE RATES: THE CONTRACTOR OR SUBCONTRACTOR SHALL PAY THE HIGHER OF THE U.S. DEPARTMENT OF LABOR MINIMUM WAGE RATES AS ESTABLISHED FOR XXXXXXXXXXXXX COUNTY, PURSUANT TO WEST VIRGINIA CODE 21-5A, ET, SEQ. (PREVAILING WAGE RATES APPLY TO THIS PROJECT)</p> <p>ARBITRATION: ANY REFERENCES MADE TO ARBITRATION OR INTEREST FOR PAYMENTS DUE (EXCEPT FOR ANY INTEREST REQUIRED BY STATE LAW) CONTAINED IN THIS CONTRACT OR IN ANY AMERICAN INSTITUTE OF ARCHITECTS DOCUMENTS PERTAINING TO THIS CONTRACT ARE HEREBY DELETED.</p> <p>WORKERS' COMPENSATION: VENDOR IS REQUIRED TO PROVIDE A CERTIFICATE FROM WORKERS' COMPENSATION IF SUCCESSFUL.</p> <p>ALL OF THE ITEMS CHECKED BELOW WILL BE A REQUIREMENT OF THIS CONTRACT:</p> <p>(XX) INSURANCE: SUCCESSFUL VENDOR SHALL FURNISH PROOF OF COMMERCIAL GENERAL LIABILITY INSURANCE PRIOR TO ISSUANCE OF CONTRACT. UNLESS OTHERWISE SPECIFIED IN THE BID DOCUMENTS, THE MINIMUM AMOUNT OF INSURANCE</p>						

SEE REVERSE SIDE FOR TERMS AND CONDITIONS

SIGNATURE <i>Ray Ellison</i>	TELEPHONE (800) 962-8618	DATE 2-1-2007
TITLE Bid Specialist	FEIN 550585890	ADDRESS CHANGES TO BE NOTED ABOVE

WHEN RESPONDING TO RFQ, INSERT NAME AND ADDRESS IN SPACE ABOVE LABELED 'VENDOR'



State of West Virginia
 Department of Administration
 Purchasing Division
 2019 Washington Street East
 Post Office Box 50130
 Charleston, WV 25305-0130

Request for Quotation

RFQ NUMBER
 LSH70143

PAGE
 3

ADDRESS CORRESPONDENCE TO ATTENTION OF:
 ROBERTA WAGNER
 304-558-0067

RFQ COPY

TYPE NAME/ADDRESS HERE

V
E
N
D
O
R

Douglas Equipment
 301 North Street
 Bluefield, WV 24701
 (304) 327-0149 1-(800) 962-8618

S
H
I
P
T
O

HEALTH AND HUMAN RESOURCES
 LAKIN HOSPITAL

1 BATEMAN CIRCLE
 LAKIN, WV
 25287

304-675-0860

DATE PRINTED 12/19/2006	TERMS OF SALE	SHIP VIA	F.O.B.	FREIGHT TERMS
BID OPENING DATE: 02/01/2007		BID OPENING TIME 01:30PM		

LINE	QUANTITY	UOP	CAT NO.	ITEM NUMBER	UNIT PRICE	AMOUNT
				COVERAGE REQUIRED IS \$250,000.		
				() BUILDERS RISK INSURANCE: SUCCESSFUL VENDOR SHALL FURNISH PROOF OF BUILDERS RISK - ALL RISK INSURANCE IN AN AMOUNT EQUAL TO 100% OF THE AMOUNT OF THE CONTRACT.		
				(XX) BONDS: FIVE PERCENT (5%) OF THE TOTAL AMOUNT OF THE BID PAYABLE TO THE STATE OF WEST VIRGINIA, SHALL BE SUBMITTED WITH EACH BID AS A BID BOND. THE SUCCESSFUL BIDDER SHALL ALSO FURNISH A PERFORMANCE BOND AND LABOR/MATERIAL BOND FOR 100% OF THE AMOUNT OF THE CONTRACT. BONDS MAY BE PROVIDED IN THE FORM OF A CERTIFIED CHECK, IRREVOCABLE LETTER OF CREDIT, OR BOND FURNISHED BY A SOLVENT SURETY COMPANY AUTHORIZED TO DO BUSINESS IN THE STATE OF WEST VIRGINIA. A LETTER OF CREDIT SUBMITTED IN LIEU OF A PERFORMANCE AND LABOR & MATERIAL BOND WILL ONLY BE ALLOWED FOR PROJECTS UNDER \$100,000. PERSONAL OR BUSINESS CHECKS ARE NOT ACCEPCTABLE IN LIEU OF THE 5% BID BOND, PERFORMANCE BOND, OR LABOR AND MATERIAL BOND.		
				() MAINTENANCE BOND: A TWO (2) YEAR MAINTENANCE BOND COVERING THE ROOFING SYSTEM WILL BE A REQUIREMENT OF THE SUCCESSFUL VENDOR.		
				REV. 11/00		
				EXHIBIT 7		
				DOMESTIC ALUMINUM, GLASS & STEEL IN PUBLIC WORKS PROJECTS		
				IN ACCORDANCE WITH WEST VIRGINIA CODE 5-19-1 ET., SEQ., EVERY CONTRACT FOR CONSTRUCTION, RECONSTRUCTION, ALTERATION, REPAIR, IMPROVEMENT OR MAINTENANCE OF		

SEE REVERSE SIDE FOR TERMS AND CONDITIONS

SIGNATURE <i>Ray Ellison</i>	TELEPHONE (800) 962-8618	DATE 2-1-2007
TITLE Bid Specialist	FEIN 550585890	ADDRESS CHANGES TO BE NOTED ABOVE

WHEN RESPONDING TO RFQ, INSERT NAME AND ADDRESS IN SPACE ABOVE LABELED 'VENDOR'



State of West Virginia
 Department of Administration
 Purchasing Division
 2019 Washington Street East
 Post Office Box 50130
 Charleston, WV 25305-0130

Request for Quotation

RFQ NUMBER
 LSH70143

PAGE
 4

ADDRESS CORRESPONDENCE TO ATTENTION OF:
 ROBERTA WAGNER
 304-558-0067

RFQ COPY
 TYPE NAME/ADDRESS HERE

VENDOR

Douglas Equipment
 301 North Street
 Bluefield, WV 24701
 (304) 327-0149 1-(800) 962-8618

SHIP TO

HEALTH AND HUMAN RESOURCES
 LAKIN HOSPITAL

 1 BATEMAN CIRCLE
 LAKIN, WV
 25287 304-675-0860

DATE PRINTED 12/19/2006	TERMS OF SALE	SHIP VIA	F.O.B.	FREIGHT TERMS
----------------------------	---------------	----------	--------	---------------

BID OPENING DATE: 02/01/2007 BID OPENING TIME 01:30PM

LINE	QUANTITY	UOP	CAT NO.	ITEM NUMBER	UNIT PRICE	AMOUNT
<p>PUBLIC WORKS, WHERE THE COST IS MORE THAN \$50,000 AND, IN THE CASE OF STEEL ONLY, WHERE THE COST OF STEEL IS MORE THAN \$50,000 OR WHERE MORE THAN 10,000 POUNDS OF STEEL ARE REQUIRED, THE STATE WILL ACCEPT ONLY ALUMINUM GLASS, OR STEEL PRODUCTS PRODUCED IN THE UNITED STATES. IN ADDITION, ITEMS OF MACHINERY OR EQUIPMENT PURCHASED FOR USE AT THE SITE OF PUBLIC WORKS SHALL BE MADE OF DOMESTIC ALUMINUM, GLASS OR STEEL, UNLESS THE COST OF THE PRODUCT IS LESS THAN \$50,000 OR LESS THAN 10,000 POUNDS OF STEEL ARE USED IN PUBLIC WORKS PROJECTS.</p> <p>FOREIGN MADE ALUMINUM, GLASS OR STEEL PRODUCTS MAY BE ACCEPTED ONLY IF THE COST OF DOMESTIC PRODUCTS IS FOUND TO BE UNREASONABLE. SUCH COST IS UNREASONABLE IF IT IS 20% OR MORE HIGHER THAN THE BID PRICE FOR FOREIGN MADE PRODUCTS. IF THE DOMESTIC ALUMINUM, GLASS OR STEEL PRODUCTS TO BE SUPPLIED OR PRODUCED IN A "SUBSTANTIAL LABOR SURPLUS AREA", AS DEFINED BY THE UNITED STATES DEPARTMENT OF LABOR, FOREIGN PRODUCTS MAY BE SUPPLIED ONLY IF DOMESTIC PRODUCTS ARE 30% OR MORE HIGHER IN PRICE THAN THE FOREIGN MADE PRODUCTS.</p> <p>IF, PRIOR TO THE AWARD OF A CONTRACT UNDER THE ABOVE PROVISIONS, THE SPENDING OFFICER OF THE SPENDING UNIT DETERMINES THAT THERE EXISTS A BID FOR LIKE FOREIGN ALUMINUM, GLASS OR STEEL THAT IS REASONABLE AND LOWER THAN THE LOWEST BID DOMESTIC PRODUCTS, THE SPENDING OFFICE MAY REQUEST, IN WRITING, A REEVALUATION AND REDUCTION IN THE LOWEST BID FOR SUCH DOMESTIC PRODUCTS. ALL VENDORS MUST INDICATE IN THEIR BID IF THEY ARE SUPPLYING FOREIGN ALUMINUM, GLASS OR STEEL.</p> <p>REV. 3/88</p> <p>EXHIBIT 9</p>						

SEE REVERSE SIDE FOR TERMS AND CONDITIONS

SIGNATURE <i>Ray Ellison</i>	TELEPHONE (800) 962-8618	DATE 2-1-2007
TITLE BID SPECIALIST	FEIN 550585890	ADDRESS CHANGES TO BE NOTED ABOVE

WHEN RESPONDING TO RFQ, INSERT NAME AND ADDRESS IN SPACE ABOVE LABELED 'VENDOR'



State of West Virginia
 Department of Administration
 Purchasing Division
 2019 Washington Street East
 Post Office Box 50130
 Charleston, WV 25305-0130

Request for Quotation

RFQ NUMBER
 LSH70143

PAGE
 5

ADDRESS CORRESPONDENCE TO ATTENTION OF:
 ROBERTA WAGNER
 304-558-0067

RFQ COPY
 TYPE NAME/ADDRESS HERE

VENDOR

Douglas Equipment
 301 North Street
 Bluefield, WV 24701
 (304) 327-0149 1-(800) 962-8618

SHIP TO

HEALTH AND HUMAN RESOURCES
 LAKIN HOSPITAL
 1 BATEMAN CIRCLE
 LAKIN, WV
 25287 304-675-0860

DATE PRINTED 12/19/2006	TERMS OF SALE	SHIP VIA	F.O.B.	FREIGHT TERMS
BID OPENING DATE: 02/01/2007		BID OPENING TIME		01:30PM

LINE	QUANTITY	UOP	CAT. NO.	ITEM NUMBER	UNIT PRICE	AMOUNT
				NOTICE FOR ISSUANCE & ACKNOWLEDGEMENT OF CONSTRUCTION PROJECT ADDENDA		
				THE ARCHITECT/ENGINEER AND/OR AGENCY SHALL BE REQUIRED TO ABIDE BY THE FOLLOWING SCHEDULE IN ISSUING CONSTRUCTION PROJECT ADDENDA FOR STATE AGENCIES:		
				(1) THE ARCHITECT/ENGINEER SHALL PREPARE THE ADDENDUM AND A LIST OF ALL PARTIES THAT HAVE PROCURED DRAWINGS AND SPECIFICATIONS FOR THE PROJECT. THE ADDENDUM AND LIST SHALL BE FORWARDED TO THE BUYER IN THE STATE PURCHASING DIVISION. THE ARCHITECT/ENGINEER SHALL ALSO SEND A COPY OF THE ADDENDUM TO THE STATE AGENCY FOR WHICH THE CONTRACT IS ISSUED.		
				(2) THE BUYER SHALL SEND THE ADDENDUM TO ALL INTERESTED PARTIES AND, IF NECESSARY, EXTEND THE BID OPENING DATE. ANY ADDENDUM SHOULD BE RECEIVED BY THE BUYER WITHIN FOURTEEN (14) DAYS PRIOR TO THE BID OPENING DATE.		
				(3) ALL ADDENDA SHOULD BE FORMALLY ACKNOWLEDGED BY ALL BIDDERS AND SUBMITTED TO THE STATE PURCHASING DIVISION AND THE STATE AUDITOR'S OFFICE. THE SAME RULES AND REGULATIONS THAT APPLY TO THE ORIGINAL BIDDING DOCUMENT SHALL ALSO APPLY TO AN ADDENDUM DOCUMENT. THE ONLY EXCEPTION MAY BE FOR AN ADDENDUM THAT IS ISSUED FOR THE SOLE PURPOSE OF CHANGING A BID OPENING TIME AND/OR DATE.		
				REV. 11/96		
				EXHIBIT 10		

SEE REVERSE SIDE FOR TERMS AND CONDITIONS

SIGNATURE <i>Ray Ellison</i>	TELEPHONE (800) 962-8618	DATE 2-1-2007
TITLE Bid Specialist	FEIN 550585890	ADDRESS CHANGES TO BE NOTED ABOVE

WHEN RESPONDING TO RFQ, INSERT NAME AND ADDRESS IN SPACE ABOVE LABELED 'VENDOR'



State of West Virginia
 Department of Administration
 Purchasing Division
 2019 Washington Street East
 Post Office Box 50130
 Charleston, WV 25305-0130

Request for Quotation

RFQ NUMBER
 LSH70143

PAGE
 6

ADDRESS CORRESPONDENCE TO ATTENTION OF:
 ROBERTA WAGNER
 304-558-0067

RFQ COPY
 TYPE NAME/ADDRESS HERE

VENDOR

Douglas Equipment
 301 North Street
 Bluefield, WV 24701
 (304) 327-0149 1-(800) 962-8618

SHIP TO

HEALTH AND HUMAN RESOURCES
 LAKIN HOSPITAL

 1 BATEMAN CIRCLE
 LAKIN, WV
 25287 304-675-0860

DATE PRINTED 12/19/2006	TERMS OF SALE	SHIP VIA	F.O.B.	FREIGHT TERMS
BID OPENING DATE: 02/01/2007		BID OPENING TIME 01:30PM		

LINE	QUANTITY	UOP	CAT NO	ITEM NUMBER	UNIT PRICE	AMOUNT
ADDENDUM ACKNOWLEDGEMENT						
I HEREBY ACKNOWLEDGE RECEIPT OF THE FOLLOWING CHECKED ADDENDUM(S) AND HAVE MADE THE NECESSARY REVISIONS TO MY PROPOSAL, PLANS AND/OR SPECIFICATION, ETC.						
ADDENDUM NOS. :						
	NO. 1	✓				
	NO. 2	✓				
	NO. 3					
	NO. 4					
	NO. 5					
I UNDERSTAND THAT FAILURE TO CONFIRM THE RECEIPT OF THE ADDENDUM(S) MAY BE CAUSE FOR REJECTION OF THE BIDS.						
					SIGNATURE	
DOUGLAS EQUIPMENT					COMPANY	
1/1/2007					DATE	
REV. 11/96						
*****INQUIRIES*****						
WRITTEN QUESTIONS SHALL BE ACCEPTED THROUGH CLOSE OF BUSINESS ON WEDNESDAY, JANUARY 17, 2007. QUESTIONS MAY BE SENT VIA USPS, FAX, COURIER OR E-MAIL. IN ORDER TO						

SEE REVERSE SIDE FOR TERMS AND CONDITIONS

SIGNATURE 	TELEPHONE (800) 962-8618	DATE 2-1-2007
TITLE Bid Specialist	FEIN 550585890	ADDRESS CHANGES TO BE NOTED ABOVE

WHEN RESPONDING TO RFQ, INSERT NAME AND ADDRESS IN SPACE ABOVE LABELED 'VENDOR'



State of West Virginia
 Department of Administration
 Purchasing Division
 2019 Washington Street East
 Post Office Box 50130
 Charleston, WV 25305-0130

Request for Quotation

RFQ NUMBER
 LSH70143

PAGE
 8

ADDRESS CORRESPONDENCE TO ATTENTION OF:
 ROBERTA WAGNER
 304-558-0067

RFQ COPY
 TYPE NAME/ADDRESS HERE

VENDOR

Douglas Equipment
 301 North Street
 Bluefield, WV 24701
 (304) 327-0149 1-(800) 962-8618

SHIP TO

HEALTH AND HUMAN RESOURCES
 LAKIN HOSPITAL
 1 BATEMAN CIRCLE
 LAKIN, WV
 25287 304-675-0860

DATE PRINTED 12/19/2006	TERMS OF SALE	SHIP VIA	F.O.B.	FREIGHT TERMS
BID OPENING DATE: 02/01/2007		BID OPENING TIME 01:30PM		

LINE	QUANTITY	UOP	CAT NO.	ITEM NUMBER	UNIT PRICE	AMOUNT
<p>COPY OF THEIR CONTRACTORS LICENSE PRIOR TO ISSUANCE OF A PURCHASE ORDER/CONTRACT</p> <p>APPLICABLE LAW</p> <p>THE WEST VIRGINIA STATE CODE, PURCHASING DIVISION RULE AND REGULATIONS, AND THE INFORMATION PROVIDED IN THE "REQUEST FOR QUOTATION" ISSUED BY THE PURCHASING DIVISION IS THE SOLE AUTHORITY GOVERNING THIS PROCUREMENT.</p> <p>ANY INFORMATION PROVIDED IN SPECIFICATION MANUALS, OR ANY OTHER SOURCE, VERBAL OR WRITTEN, WHICH CONTRADICTS OR ALTERS THE INFORMATION PROVIDED FROM THE SOURCES AS DESCRIBED IN THE ABOVE PARAGRAPH IS VOID AND OF NO EFFECT.</p> <p>BANKRUPTCY: IN THE EVENT THE VENDOR/CONTRACTOR FILES FOR BANKRUPTCY PROTECTION, THIS CONTRACT IS AUTOMATICALLY NULL AND VOID, AND IS TERMINATED WITHOUT FURTHER ORDER.</p> <p>REV. 1/2005</p> <p>NOTICE</p> <p>A SIGNED BID MUST BE SUBMITTED TO:</p> <p>DEPARTMENT OF ADMINISTRATION PURCHASING DIVISION BUILDING 15 2019 WASHINGTON STREET, EAST CHARLESTON, WV 25305-0130</p>						

SEE REVERSE SIDE FOR TERMS AND CONDITIONS

SIGNATURE *Ray Edison* TELEPHONE (800) 962-8618 DATE 2-1-2007
 TITLE Bid Specialist FEIN 550585890 ADDRESS CHANGES TO BE NOTED ABOVE

WHEN RESPONDING TO RFQ, INSERT NAME AND ADDRESS IN SPACE ABOVE LABELED 'VENDOR'



State of West Virginia
 Department of Administration
 Purchasing Division
 2019 Washington Street East
 Post Office Box 50130
 Charleston, WV 25305-0130

Request for Quotation

RFQ NUMBER
 LSH70143

PAGE
 9

ADDRESS CORRESPONDENCE TO ATTENTION OF:
 ROBERTA WAGNER
 304-558-0067

RFQ COPY
 TYPE NAME/ADDRESS HERE

V
E
N
D
O
R

Douglas Equipment
 301 North Street
 Bluefield, WV 24701
 (304) 327-0149 1-(800) 962-8618

S
H
I
P
T
O

HEALTH AND HUMAN RESOURCES
 LAKIN HOSPITAL
 1 BATEMAN CIRCLE
 LAKIN, WV
 25287 304-675-0860

DATE PRINTED 12/19/2006	TERMS OF SALE	SHIP VIA	F.O.B.	FREIGHT TERMS
BID OPENING DATE: 02/01/2007		BID OPENING TIME 01:30PM		

LINE	QUANTITY	UOP	CAT NO.	ITEM NUMBER	UNIT PRICE	AMOUNT
THE BID SHOULD CONTAIN THIS INFORMATION ON THE FACE OF THE ENVELOPE OR THE BID MAY NOT BE CONSIDERED: SEALED BID BUYER: FILE 22 REQ. NO.: LSH70143 BID OPENING DATE: FEBRUARY 1, 2007 BID OPENING TIME: 1:30 PM PLEASE PROVIDE A FAX NUMBER IN CASE IT IS NECESSARY TO CONTACT YOU REGARDING YOUR BID: ----- (304) 325-3848 ----- PLEASE PRINT OR TYPE NAME OF PERSON TO CONTACT CONCERNING THIS QUOTE: ----- Roy Ellison ----- ***** THIS IS THE END OF RFQ LSH70143 ***** TOTAL: <u>\$48,444.00</u>						

SEE REVERSE SIDE FOR TERMS AND CONDITIONS

SIGNATURE <i>Roy Ellison</i>	TELEPHONE (800) 962-8618	DATE 2-1-2007
TITLE BID SPECIALIST	FEIN 550585890	ADDRESS CHANGES TO BE NOTED ABOVE

WHEN RESPONDING TO RFQ, INSERT NAME AND ADDRESS IN SPACE ABOVE LABELED 'VENDOR'

1. GENERAL INFORMATION:

1.1 Contractor shall furnish all labor, materials, equipment and anything incidental to the installation of the following equipment at Lakin Hospital.

1. Hobart "or equal" Model CRS66A commercial dishwashing unit with a 30 KW pressure less booster heater, stainless steel vent hoods with vent stack and locking damper, and electric blower-dryer or equal.
2. Hobart "or equal" DDU38 direct drive unloader to be constructed of 14-gauge steel with covered corners and attached to the clean side of the dishwasher by stainless steel bolts. The unit shall be 208/240 volt, 3 phase.
3. Hobart "or equal" SL-30 Side Loader. Stainless steel, reciprocating, 14 gauge with covered corners attached to the dishwasher chamber with stainless steel bolts. Sump has 1 ½ drain connection and perforated stainless steel strainer cover over drain opening.
4. Stainless steel clean dish table attached to unloader.
5. Stainless steel soiled dish table, with disposer with pre-rinse sink and pre-rinse spray attached to side loader.

1.2 This shall be a 100% turnkey installation. All work will be in compliance with the Fire Marshall regulations and all other building codes and industry standards. Final payment will be withheld if installed components are not in compliance, or any portion of this overall project is not 100% complete. The award will be made to the overall low bid that complies with the specifications.

1.3 The words "will", "must", and "shall" identify a mandatory requirement.

2. BIDDER REQUIREMENTS:

- 2.1 All vendors shall attend the mandatory vendor prebid conference to discuss any questions; measurements of job site; or concerns of the bid and to examine the job site.
- 2.2 It is the vendor's responsibility to verify all field conditions and limitations prior to bidding. It is also the vendor's responsibility to notify the West Virginia Department of Health & Human Resources in writing, of conditions detrimental to proper and timely completion of the repair/upgrade. Do not proceed until nonconforming conditions have been corrected.

3. SCOPE OF WORK:

- 3.1 Minor deviations from the stated specification not listed as mandatory (must, shall, or will) are acceptable to facilitate a competitive bidding atmosphere provided the intent of the Request for Quotation or the effectiveness of the

system is not compromised.

- 3.2 The objective of this RFQ to obtain a contract for the delivery, purchase, set up installation of a Hobart Model CRS66A Dishwasher "or equal". The dishwasher is a fully automatic, right to left operation, 202 racks per hour, top mounted controls, stainless steel frame (chamber 6" higher than standard), stainless steel anti-clogging fixed wash arms, automatic fill, fixed pump intake screen, with a 3 phase, 10.28 amp, 208/240 volt motor.
 - 3.2.1 Contractor shall furnish and install tray rack constructed of plastic and stainless steel with chrome-plated wire for Hobart "or equal" C-Line Models 6" higher than standard.
 - 3.2.2 Contractor shall furnish and install a stainless steel vent hood (4 X 16) with vent stack and locking-type damper designed to fit either end of the dishwasher.
 - 3.2.3 Contractor shall furnish and install a Hobart "or equal" Model number DDU38-R/L Direct Drive unloader with a 3/4" brass pressure regulator.
 - 3.2.4 Contractor shall provide and install an electric blower-dryer (3-phase only).
 - 3.2.5 Contractor shall provide and install a stainless steel booster heater, 30 KW minimum.
- 3.3 Contractor shall furnish and install a Hobart "or equal" Dishwasher Disposer Model Number FD3/300-1, with 3 HP motor, aluminum housing, adjustable feet, 208/240 volts, 3 phase.
- 3.4 Contractor shall furnish and install a clean dish table sized and shaped per the space dedicated for this component. Unit shall be constructed with 300 series 14-gauge stainless steel top. Top has 10" backsplash at rear with 45-degree turn back at top. Unit shall be sloped toward dishwasher. Table shall be built to match up with Unloader.
- 3.5 Contractor shall furnish and install a sink mixing faucet with 12" swing nozzle, wall mounted, 8" centers on sink faucet with 1/2" IPS male inlets.
- 3.6 Contractor shall furnish and install soiled dish table sized and shaped per the space dedicated for this component. Unit shall be constructed with 300 series 14-gauge stainless steel top. Top has 10" backsplash at rear with 45 degrees turn back at top. Unit shall be sloped toward dishwasher. Table shall be built to match up with Side Loader and include a Pre-rinse sink welded in ring, scrap trough 6" wide X 54" long flowing into sink.
- 3.7 Contractor shall furnish and install an easy install pre rinse unit, wall mounted,

base faucet with spring check cartridges and level handles, 1" long NPT male inlets, 15" overhang, 18" riser, and a flexible hose.

- 3.8 The completed equipment and installation must meet the requirements of the National Sanitary Foundation (NSF) and American Society of Sanitary Engineering Standard No. 1004.
- 3.9 Contractor shall identify necessary materials and electrical equipment to be installed and prepare shop drawings for approval on all fire and/or smoke-rated wall and floor penetrations. Contractor shall install equipment to facilitate servicing, maintenance, and repair or replacement of equipment components. As much as practical, connect equipment for ease of disconnecting, with minimum of interference with other installations.
- 3.10 Any wire ways the Contractor installs shall be of types, sizes, and number of channels as necessary to complete scope of work. Fittings and accessories including but not limited to couplings, offsets, elbows, expansion joints, adapters, and end caps shall match and mate with wire way as required for a complete system.
- 3.11 Contractor shall cut existing construction to provide for installation of electrical components and the subsequent fitting and patching shall be required to restore surfaces to their original or better condition.
- 3.12 Contractor shall determine load requirements. Contractor shall be responsible for installation of the dishwasher line that is in compliance with all Federal, State, and local building and sanitation codes.
- 3.13 Hospital maintenance staff will remove the existing dishwasher and prepare the room for installation of new equipment. In accordance with Section 2.2, Contractor shall notify owner of any condition detrimental to the installation of the new equipment.

4. INSPECTION:

- 4.1 Contractor shall inspect existing conditions governing this work during pre-bid site inspection to determine conditions and extent of work required. No allowance will be made subsequently on behalf of the contractor for any error or negligence on his part in connection with this requirement.
- 4.2 The Contractor shall inspect all elements subject to movement or damage prior to commencing work.

5. SHOP DRAWINGS:

- 5.1 Contractor shall provide shop drawings to owner for approval specifying products and installation methods for the scope of work as defined in Section 3. A notice to proceed will be issued indicating approval of the shop drawings.

6. TEMPORARY FACILITIES:

- 6.1 The Owner will provide normal electrical supply from the currently installed electrical system in the building for the use of the contractor. However, the Owner provides no guarantee or warranty as to the systems condition or capabilities. The Contractor shall assure himself that the electrical system is adequate for his requirements or supply additional temporary electrical power at his own expense.
- 6.2 Any damage to the electrical system resulting from misuse or abuse to the existing electrical system shall be repaired or replaced by the contractor at no expense to the owner.

7. COORDINATION OF WORK:

- 7.1 The Contractor shall coordinate with the maintenance supervisor for the proper relation of the work to the building structure and to the employees therein. In the event of conflict the building employees shall prevail.
- 7.2 The Contractor shall take all necessary precautions to protect the interior of the building from debris, dust or any residue occurring from the scope of work.
- 7.3 The Contractor shall provide the Owner with a schedule of work seven calendar days prior to the start of the work. The Owner shall be notified of any variances to the work schedule two (2) working days prior to the change.

8. WARRANTY: (GUARANTEE)

- 8.1 The Contractor shall warrant to the Owner all materials and equipment will be new, and that all work will be of good quality, free from faults and defects in conformance with the contract documents. All work not conforming to these requirements may be considered defective. If the product warranty requires the contractor to have a factory representative to inspect and approve the installation, that will be completed prior to Owner acceptance.
- 8.2 All materials and equipment shall be of current year production of manufacturer and manufactured for commercial usage. Used, reconditioned or remanufactured equipment is not acceptable.

9. PERMITS:

- 9.1 The Contractor shall secure and pay for the building permit and for all other permits, governmental fees and licenses which are necessary for the proper execution and completion of the work as specified.

10. CLEAN UP:

10.1 The Contractor shall keep the work area as clean as possible during the entire progress of work, and shall be responsible to remove from the site, the packaging materials from his products and other debris as it accumulates. All items of equipment that are removed, to allow the installation of new items, will become the property of the contractor to dispose of at a landfill or location authorized to accept the items as waste or recycled parts

11. WAGE RATES:

11.1 The Contractor and any sub-contractors shall pay the higher of the U S. Department of Labor Minimum wage rates or of the West Virginia Department of Labor wage rates as established for MASON County pursuant to West Virginia Code 21-5-1, et seq. West Virginia Department of Labor Wage Rates are available at website: <http://www.wvsos.com/adlaw/wagerates/building06.htm>

12. PAYMENT SCHEDULE:

12.1 The Contractor shall submit to the Owner, one original invoice, (when the contracted work is completed in its entirety) and upon inspection and approval by the Owner.

12.2 The Owner reserves the right to refuse payment in the event the completed work is not in accordance with industry standards or sub-standard in any way, or, if the amount requested is not within the agreed upon terms of the contract.

13. TERM OF WORK:

13.1 All work shall be complete within 90 calendar days from the approval of the shop drawings.

14. DELAYS AND EXTENSION OF TIME:

14.1 If the Contractor is delayed at any time in the progress of the work by any act or neglect of the Owner or by any employee of the Owner, or by any separate contractor employed by the Owner, or by changes in the work, or by labor disputes, fire, unusual delay in transportation, adverse weather conditions not reasonably anticipated, unavoidable casualties, or any other cause which the Owner determines may justify the delay, then the contract time may be extended by written approval of the Owner.

15. TOOLS AND EQUIPMENT STORAGE:

15.1 Contractor may set a trailer or temporary storage building on the site for all equipment and tools. The Contractor is responsible for his tools, equipment and materials.

16. SAFETY EQUIPMENT:

- 16.1 The Contractor shall provide safety barriers around work areas where heavy equipment may be in operation when placing materials in the building or as required by OSHA.

17. DAMAGES:

- 17.1 Any damages occurring to the building or property resulting from the contractor's performance of this work shall be the responsibility of the contractor to repair at his expense, either by using his own forces or that of an approved sub-contractor. The repair method and finished product will be subject to the approval of the owner.
- 17.2 Insurance Requirements: Insurance certificates are required prior to award but are not required at the time of bid. Vendor shall present evidence of insurance at the time of award in the types and amounts required by the Agency and acceptable to the State. Included in the required insurance coverage shall be the following:
1. For bodily injury (including death): minimum of \$500,000 per person & \$1,000,000 per occurrence.
 2. For property damage and liability: minimum of \$250,000 per occurrence.

18. COMPLIANCE WITH LAW AND REGULATIONS

The vendor shall pay any sales, use, and personal property taxes arising out of this contract and the transactions contemplated thereby. Any other taxes levied upon this contract, the transaction, or the equipment, or services delivered pursuant hereto shall be borne by the vendor. The vendor shall comply with all related federal and state laws and regulations. The vendor shall comply with all applicable laws, rules, and regulations including, but not limited to those relating to hospital licensure, State and Federal labor laws and laws, rules, and policies related to the West Virginia Department of Health and Human Resources.

19. BID RESPONSE:

- 19.1 Bidder shall submit one lump sum bid for all the work under all the terms and conditions as described herein.
- 19.2 Successful bidder should submit full commercial warranty information with the bid. The warranty information shall minimally contain the product warranty and labor warranty product.
- 19.3 Vendor is requested to attach descriptive literature of the equipment being bid.

BID BOND

KNOW ALL MEN BY THESE PRESENTS That we, the undersigned Douglas Food Stores, Inc. DBA Douglas Equipment
of 301 North Street Bluefield, WV 24701 as Principal and Contractors Bonding and Insurance
Company of 1213 Valley Street, Seattle, WA 98109, a corporation organized and existing under the laws of the State of WV
with its principal office in the City of Seattle, WA as Surety are held and firmly bound unto the State
of West Virginia as Oblige in the penal sum of 5% of Bid Amount (\$ 5% of Bid Amount) for the payment of which
well and truly to be made. we jointly and severally bind ourselves our heirs administrators executors successors and assigns

The Condition of the above obligation is such that whereas the Principal has submitted to the Purchasing Section of the
Department of Administration a certain bid or proposal attached hereto and made a part hereof, to enter into a contract in writing for
Delivery and installation of kitchen equipment at Lakin Hospital, Lakin, WV 25287

NOW THEREFORE

- (a) If said bid shall be rejected, or
- (b) If said bid shall be accepted and the Principal shall enter into a contract in accordance with the bid or proposal attached hereto and shall furnish any other bonds and insurance required by the bid or proposal, and shall in all other respects perform the agreement created by the acceptance of said bid, then this obligation shall be null and void otherwise this obligation shall remain in full force and effect It is expressly understood and agreed that the liability of the Surety for any and all claims hereunder shall in no event exceed the penal amount of this obligation as herein stated.

The Surety, for the value received, hereby stipulates and agrees that the obligations of said Surety and its bond shall be in no way impaired or affected by any extension of the time within which the Oblige may accept such bid and said Surety does hereby waive notice of any such extension

IN WITNESS WHEREOF, Principal and Surety have hereunto set their hands and seals and such of them as are corporations have caused their corporate seals to be affixed hereunto and these presents to be signed by their proper officers this
31st day of January, 20 07

Principal Corporate Seal

Douglas Food Stores, Inc. DBA
Douglas Equipment

(Name of Principal)

By

(Must be President or
Vice President)

PRESIDENT

(Title)

Surety Corporate Seal

Contractors Bonding and Insurance Company

(Name of Surety)

Brandi J. Sturgill
Attorney-in-Fact

IMPORTANT - Surety executing bonds must be licensed in West Virginia to transact surety insurance. Raised corporate seals must be affixed, a power of attorney must be attached

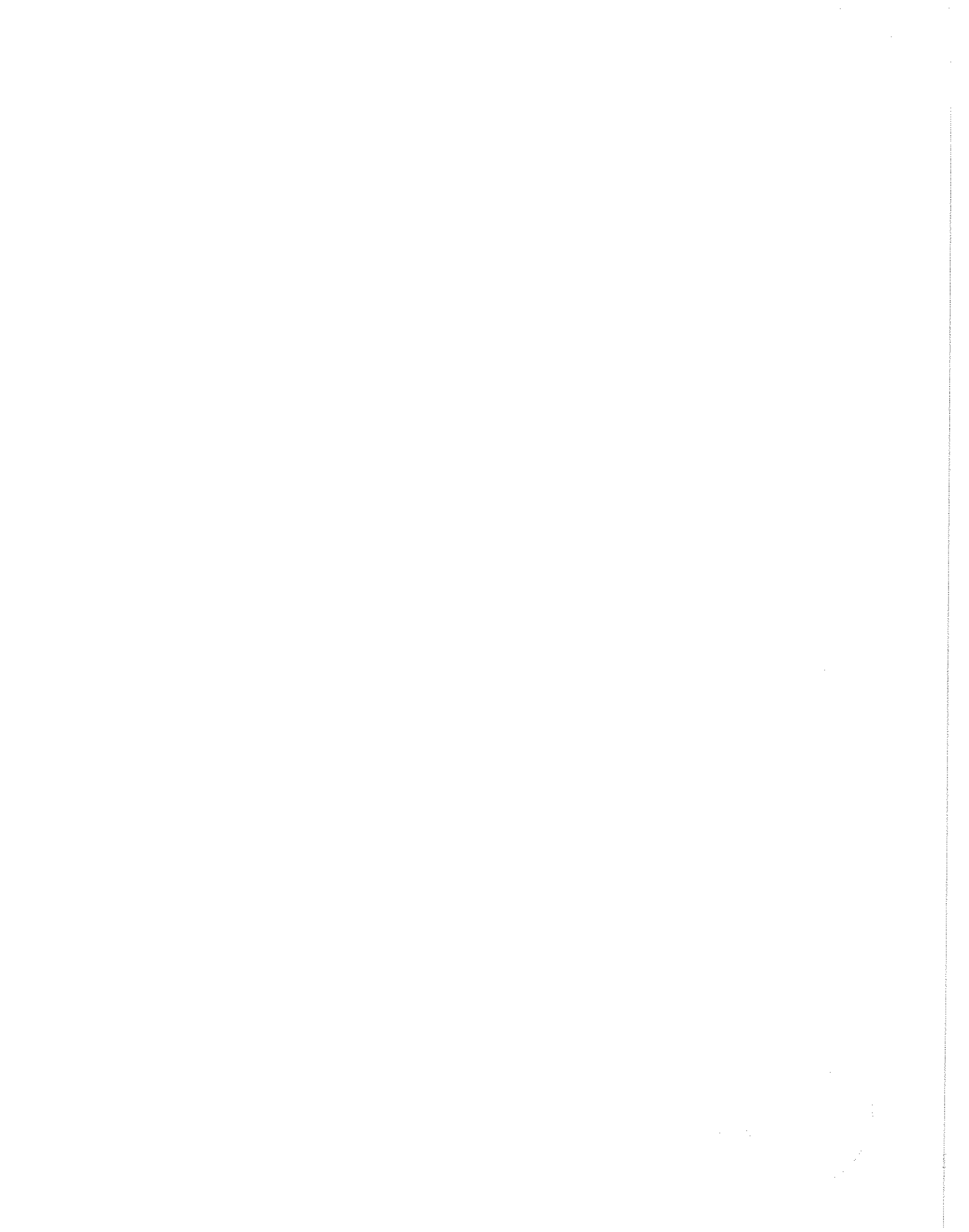

LIMITED POWER OF ATTORNEY - READ CAREFULLY

CONTRACTORS BONDING AND INSURANCE COMPANY IS RESPONSIBLE ONLY FOR THE BOND DESCRIBED AND UP TO THE AMOUNT SET FORTH IN THIS LIMITED POWER OF ATTORNEY. ANY ERASURE WILL VOID THIS POWER OF ATTORNEY IF YOU HAVE ANY QUESTIONS ABOUT OR WANT TO VERIFY THIS POWER OF ATTORNEY CALL CONTRACTORS BONDING AND INSURANCE COMPANY TOLL FREE AT 1(800)765-2242

Penal Sum : \$ \$2,422.20 Attorney No : WV059 Power Number : E04667 Bond No : BID

Limited Power of Attorney Expires: 4/30/2007 Date Approved : 1/31/2007

Approved by : [Signature] Don Sirkin
(Signature) (Print Name)

Name of Principal: DOUGLAS FOOD STORES, INC. DBA DOUGLAS EQUIPMENT

Name of Obligee: STATE OF WEST VIRGINIA

Descriptions(s): DELIVERY AND INSTALLATION OF KITCHEN EQUIPMENT AT LAKIN HOSPITAL, LAKIN, WV 25287

Location (if applicable): LAKIN, WEST VIRGINIA

KNOW ALL MEN BY THESE PRESENTS that CONTRACTORS BONDING AND INSURANCE COMPANY, a corporation duly organized and existing under the laws of the State of Washington and having its principal office in Seattle, King County, Washington does by these presents make, constitute and appoint BRENDA G. STURGILL OF PRINCETON WV its true and lawful Attorney-in-Fact, with full power and authority hereby conferred in its name, place and stead, to execute, acknowledge and deliver the bond(s) and/or other documents incidental thereto described above; and to bind the Company thereby as fully and to the same extent as if each such bond, or other documents incidental thereto was signed by the President, sealed with the corporate seal of the Company and duly attested by its Secretary; hereby ratifying and confirming all that the said Attorney-In-Fact may do in the premises. Said appointment is made under and by the authority of the following resolutions adopted by the Board of Directors of CONTRACTORS BONDING AND INSURANCE COMPANY on September 10, 2001

RESOLVED that the Chief Executive Officer, President, Chief Financial Officer, Secretary or any Vice President of the Company is authorized to appoint Attorneys-In-Fact for and on behalf of the Company with the power and authority to sign on behalf of the Company those surety bonds and undertakings of suretyship which may from time to time be approved by the Chief Executive Officer, President, Chief Financial Officer, Secretary or any Vice President of the Company; provided, however, that no Attorney-In-Fact shall be authorized to execute and deliver any bond or undertaking that shall obligate the Company for any portion of the penal sum thereof in excess of \$15,000,000, and provided, further, that no Attorney-In-Fact shall have the authority to issue a bid or proposal bond for any project where, if the contract is awarded, any bond or undertaking would be required with a penal sum in excess of \$15,000,000. An Attorney-In-Fact may also be authorized by Power of Attorney to execute any consent or other document incidental to said bond or undertaking, provided such document does not obligate the Company in excess of the limit set forth above. In no event shall any Attorney-In-Fact have any authority to sign any document or otherwise bind the Company in any way in connection with a claim on a surety bond or undertaking

RESOLVED FURTHER that each Power of Attorney must set forth the specific description of the surety bond or undertaking to which it applies, the name of the principal, the name of the obligee, the penal sum, the bond number (except for a bid bond where there is no number), the identifying number of the Attorney-In-Fact, and the identifying number of the Power of Attorney. The Attorney-In-Fact shall not be authorized to obligate Company for surety bond or undertaking specified in the Power of Attorney (including any consents or other documents incidental to the surety bond or undertaking) for more than the penal sum specified in the Power of Attorney

RESOLVED FURTHER that the Chief Executive Officer, President, Chief Financial Officer, Secretary or any Vice President of the Company is authorized to establish a specific expiration date for the Power of Attorney and to modify that date from time to time as the Chief Executive Officer, President, Chief Financial Officer, Secretary or any Vice President of the Company deems necessary in his/her sole discretion; the applicable expiration date is to be clearly set forth in any written Power of Attorney

RESOLVED FURTHER that all previous resolutions by the Board of Directors authorizing the Chief Executive Officer, President, Chief Financial Officer, Secretary or any Vice President of the Company to appoint Attorneys-In-Fact for and on behalf of the Company remain in full force and effect; and that if a Power of Attorney based on this resolution is attached to a bond (for example, a bid bond), and a Power of Attorney based on another Board of Directors resolution is attached to another bond (for example, a performance and payment bond), it shall not affect the validity of either Power of Attorney or Bond

RESOLVED FURTHER that this Limited Power of Attorney containing this and the foregoing resolutions and the signatures of the President, Secretary, and Notary Public, and the corporate and Notary seals appearing hereon, are generated, stored and transmitted electronically, and therefore appear in printed form only at recipient's fax machine. This fax printed Limited Power of Attorney document and the signatures and seals appearing hereon therefore are, and shall be deemed originals in all respects.

RESOLVED FURTHER that the Company acknowledges the applicability of the Electronic Signatures in Global and National Commerce Act to this Limited Power of Attorney and that the signatures of the President, Secretary and Notary Public and the corporate and Notary seals appearing on any Limited Power of Attorney containing this and the foregoing resolutions as well as the Limited Power of Attorney itself and its transmission may be, or may be by facsimile or other means of electronic or electro-mechanical transmission or reproduction; and any such Limited Power of Attorney shall be deemed an original in all respects

IN WITNESS WHEREOF CONTRACTORS BONDING AND INSURANCE COMPANY has caused these presents to be signed by Don Sirkin and its corporate seal to be hereto affixed 9/9/2002

[Signature]

CONTRACTORS BONDING AND INSURANCE COMPANY



By: Don Sirkin, President

STATE OF WASHINGTON - COUNTY OF KING

On 9/9/2002, personally appeared DON SIRKIN to me known to be the representative of the corporation that executed the foregoing Limited Power of Attorney and acknowledged said Limited Power of Attorney to be free and voluntary act and deed of said corporation, for the uses and purposes therein mentioned, and on oath stated that he is authorized to execute the said Limited Power of Attorney

IN WITNESS WHEREOF, I have hereunto set my hand and affixed my official seal the day and year first above written



Brenda J. Scott

Notary Public in and for the State of Washington, residing at Seattle

The undersigned acting under authority of the Board of Directors of CONTRACTORS BONDING AND INSURANCE COMPANY, hereby certifies, as or in lieu of Certificate of the Secretary of CONTRACTORS BONDING AND INSURANCE COMPANY, that the above and foregoing is a full, true and correct copy of the Original Power of Attorney issued by said Company, and does hereby further certify that the said Power of Attorney is still in force and effect.

GIVEN under my hand at Davidson, NC _____ this 31 _____ day of JAN _____ 2007 _____

[Signature]

R Kirk Eland, Secretary

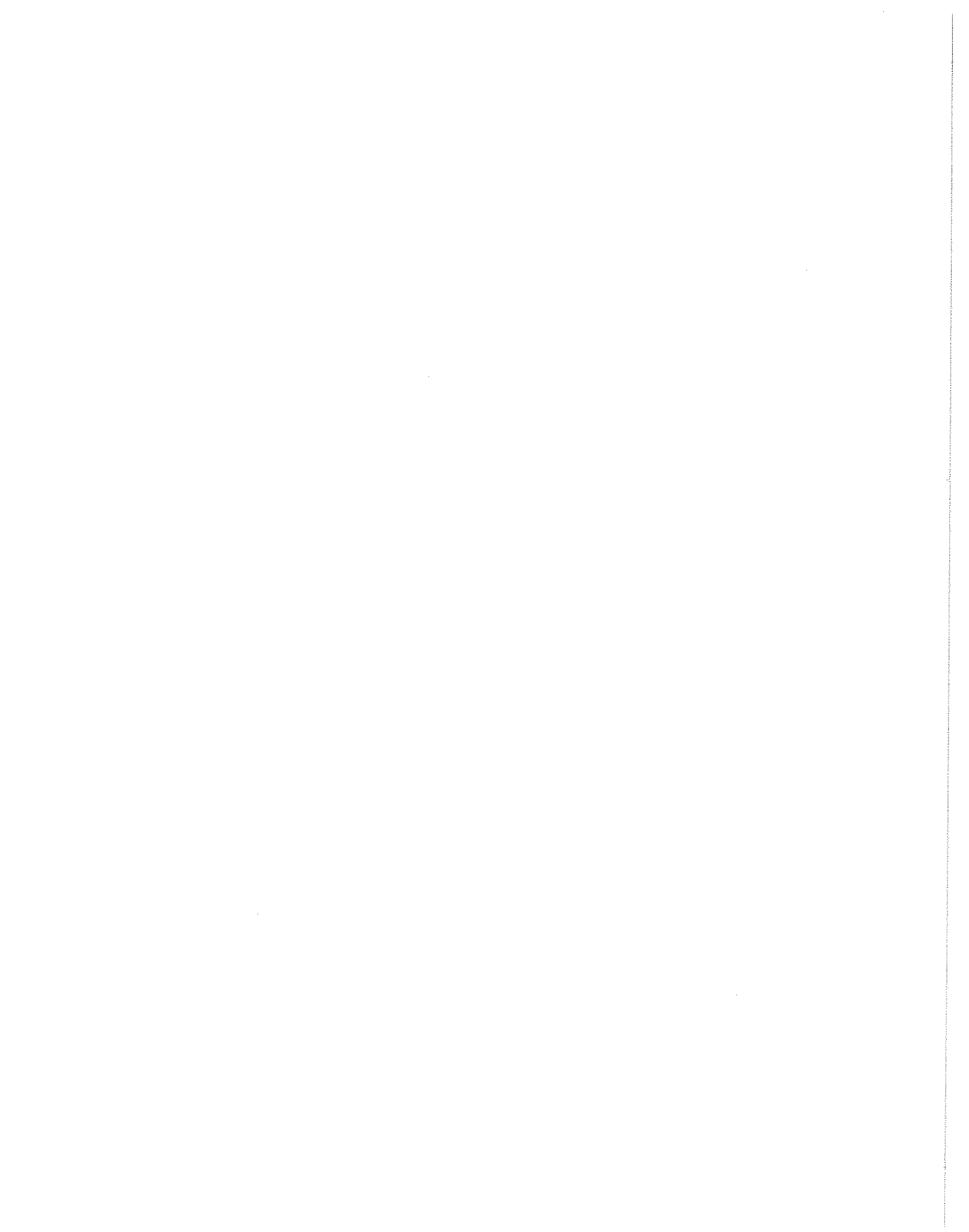

BID BOND PREPARATION INSTRUCTIONS

AGENCY _____ (A)
RFQ/RFP# _____ (B)

Bid Bond

- (A) WV State Agency
(Stated on Page 1 "Spending Unit")
Request for Quotation Number (upper right corner of page #1)
- (C) Your Company Name
- (D) City, Location of your Company
- (E) State, Location of your Company
- (F) Surety Corporate Name
- (G) City, Location of Surety
- (H) State, Location of Surety
- (I) State of Surety Incorporation
- (J) City of Surety Incorporation
- (K) Minimum amount of acceptable bid bond is 5% of total bid. You may state "5% of bid" or a specific amount on this line in words.
- (L) Amount of bond in figures
- (M) Brief Description of scope of work
- (N) Day of the month
- (O) Month
- (P) Year
- (Q) Name of Corporation
- (R) Raised Corporate Seal of Principal
- (S) Signature of President or Vice President
- (T) Title of person signing
- (U) Raised Corporate Seal of Surety
- (V) Corporate Name of Surety
- (W) Counter Signature by WV agent
- (X) Signature of Attorney in Fact of the Surety

NOTE: Dated, Power of Attorney with Raised Surety Seal must accompany this bid bond.

KNOW ALL MEN BY THESE PRESENTS, That we, the undersigned, _____ (C) of _____ (D), _____ (E) as Principal, and _____ (F) of _____ (G), _____ (H), a corporation organized and existing under the laws of the State of _____ (I) with its principal office in the City of _____ (J), as Surety, are held and firmly bound unto The State of West Virginia, as Obligee, in the penal sum of _____ (K) (\$ _____ (L)) for the payment of which, well and truly to be made, we jointly and severally bind ourselves, our heirs, administrators, executors, successors and assigns

The Condition of the above obligation is such that whereas the Principal has submitted to the Purchasing Section of the Department of Administration a certain bid or proposal, attached hereto and made a part hereof to enter into a contract in writing for _____ (M)

NOW THEREFORE

(a) If said bid shall be rejected, or

(b) If said bid shall be accepted and the Principal shall enter into a contract in accordance with the bid or proposal attached hereto and shall furnish any other bonds and insurance required by the bid or proposal, and shall in all other respects perform the agreement created by the acceptance of said bid then this obligation shall be null and void, otherwise this obligation shall remain in full force and effect. It is expressly understood and agreed that the liability of the Surety for any and all claims hereunder shall, in no event, exceed the penal amount of this obligation as herein stated

The Surety for value received, hereby stipulates and agrees that the obligations of said Surety and its bond shall be in no way impaired or affected by any extension of time within which the Obligee may accept such bid: and said Surety does hereby waive notice of any such extension.

IN WITNESS WHEREOF, Principal and Surety have hereunto set their hands and seals, and such of them as are corporations have caused their corporate seals to be affixed hereto and these presents to be signed by their proper officers, this _____ (N) day of _____ (O), 20 _____ (P).

Principal Corporate Seal _____

(R)

_____ (Q)
(Name of Principal)
By _____ (S)
(Must be President or Vice President)
_____ (T)
Title

Surety Corporate Seal _____

(U)

_____ (V)
(Name of Surety)

Countersigned:

_____ (W)
Resident West Virginia Agent

_____ (X)
Attorney-in-Fact

IMPORTANT - Surety executing bonds must be licensed in West Virginia to transact surety insurance. Corporate seals must be affixed, a power of attorney must be attached, and a West Virginia resident must sign or countersign.

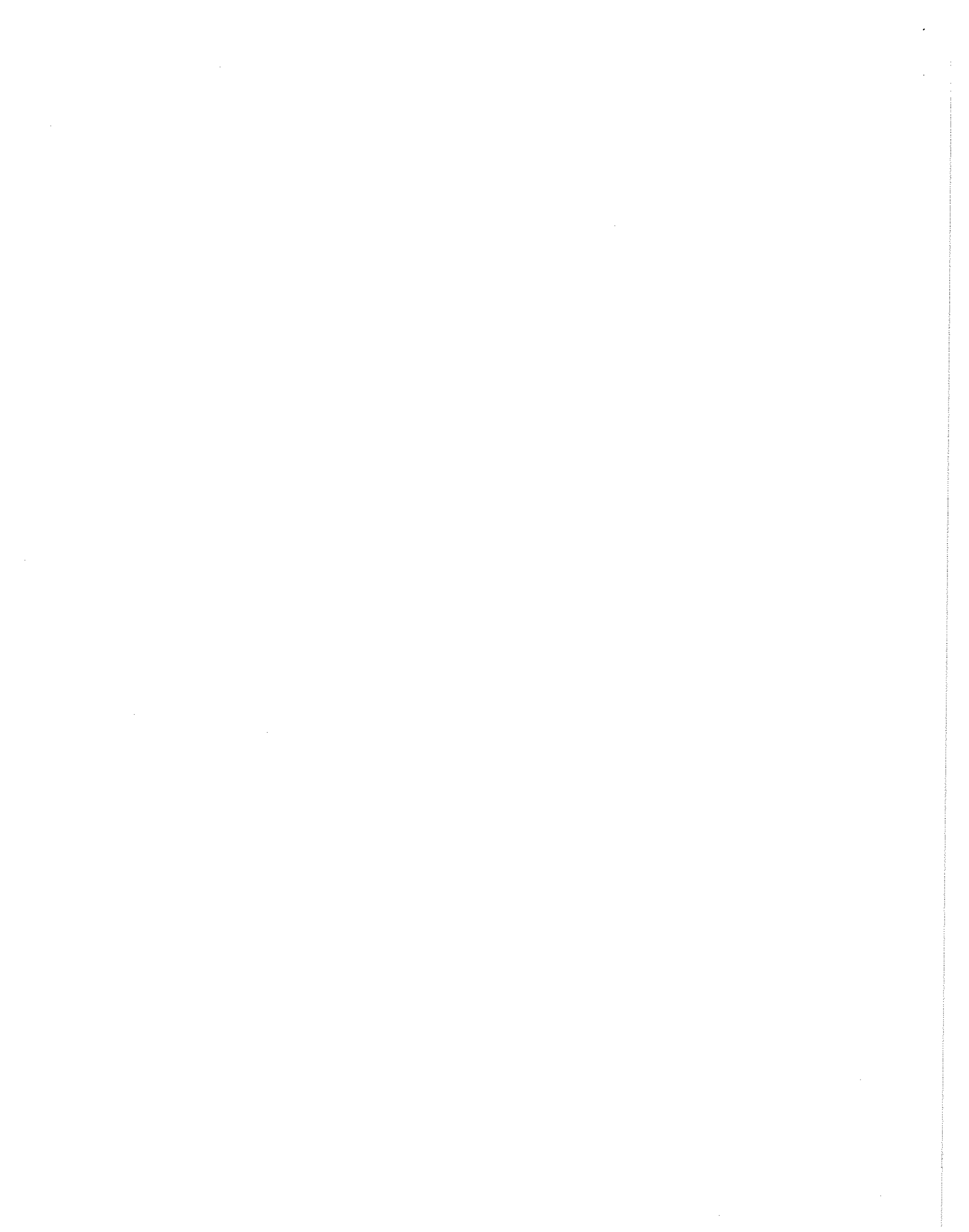

A F F I D A V I T**West Virginia Code §5A-3-10a states:**

No contract or renewal of any contract may be awarded by the state or any of its political subdivisions to any vendor or prospective vendor when the vendor or prospective vendor or a related party to the vendor or prospective vendor is a debtor and the debt owned is an amount greater than one thousand dollars in the aggregate

DEFINITIONS:

"Debt" means any assessment, premium, penalty, fine, tax or other amount of money owed to the state or any of its political subdivisions because of a judgment, fine, permit violation, license assessment, defaulted workers' compensation premium, penalty or other assessment presently delinquent or due and required to be paid to the state or any of its political subdivisions, including any interest or additional penalties accrued thereon.

"Debtor" means any individual, corporation, partnership, association, limited liability company or any other form or business association owing a debt to the state or any of its political subdivisions. "Political subdivision" means any county commission; municipality; county board of education; any instrumentality established by a county or municipality; any separate corporation or instrumentality established by one or more counties or municipalities, as permitted by law; or any public body charged by law with the performance of a government function or whose jurisdiction is coextensive with one or more counties or municipalities. "Related party" means a party, whether an individual, corporation, partnership, association, limited liability company or any other form or business association or other entity whatsoever, related to any vendor by blood, marriage, ownership or contract through which the party has a relationship of ownership or other interest with the vendor so that the party will actually or by effect receive or control a portion of the benefit, profit or other consideration from performance of a vendor contract with the party receiving an amount that meets or exceeds five percent of the total contract amount.

EXCEPTION:

The prohibition of this section does not apply where a vendor has contested any tax administered pursuant to chapter eleven of this code, workers' compensation premium, permit fee or environmental fee or assessment and the matter has not become final or where the vendor has entered into a payment plan or agreement and the vendor is not in default of any of the provisions of such plan or agreement.

LICENSING:

Vendors must be licensed and in good standing in accordance with any and all state and local laws and requirements by any state or local agency of West Virginia, including, but not limited to, the West Virginia Secretary of State's Office, the West Virginia Tax Department, West Virginia Insurance Commission, or any other state agencies or political subdivision. Furthermore, the vendor must provide all necessary releases to obtain information to enable the Director or spending unit to verify that the vendor is licensed and in good standing with the above entities.

CONFIDENTIALITY:

The vendor agrees that he or she will not disclose to anyone, directly or indirectly, any such personally identifiable information or other confidential information gained from the agency, unless the individual who is the subject of the information consents to the disclosure in writing or the disclosure is made pursuant to the agency's policies, procedures and rules. Vendors should visit www.state.wv.us/admin/purchase/privacy for the Notice of Agency Confidentiality Policies.

Under penalty of law for false swearing (West Virginia Code, §61-5-3), it is hereby certified that the vendor acknowledges the information in this said affidavit and are in compliance with the requirements as stated.

Vendor's Name: DOUGLAS EQUIPMENT

Authorized Signature:  Date: 2-1-2007

No Debt Affidavit (Revised 10/13/06)

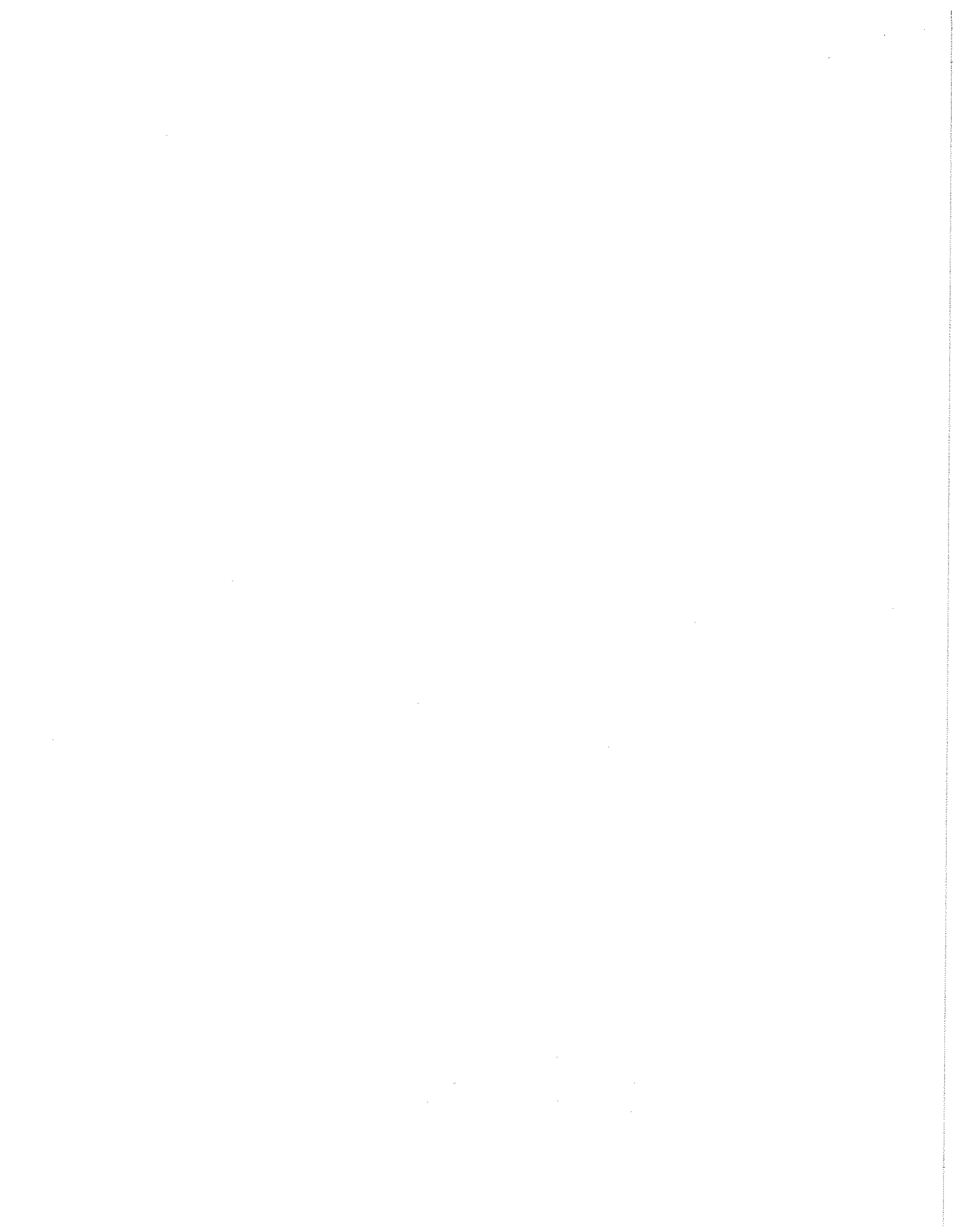

**GENERAL TERMS & CONDITIONS
REQUEST FOR QUOTATION (RFQ) AND REQUEST FOR PROPOSAL (RFP)**

1. Awards will be made in the best interest of the State of West Virginia.
2. The State may accept or reject in part, or in whole, any bid.
3. All quotations are governed by the *West Virginia Code* and the *Legislative Rules* of the Purchasing Division.
4. Prior to any award, the apparent successful vendor must be properly registered with the Purchasing Division and have paid the required \$125.00 registration fee.
5. All services performed or goods delivered under State Purchase Orders/Contracts are to be continued for the term of the Purchase Order/Contract, contingent upon funds being appropriated by the Legislature or otherwise being made available. In the event funds are not appropriated or otherwise available for these services or goods, this Purchase Order/Contract becomes void and of no effect after June 30.
6. Payment may only be made after the delivery and acceptance of goods or services.
7. Interest may be paid for late payment in accordance with the *West Virginia Code*.
8. Vendor preference will be granted upon written request in accordance with the *West Virginia Code*.
9. The State of West Virginia is exempt from federal and state taxes and will not pay or reimburse such taxes.
10. The Director of Purchasing may cancel any Purchase Order/Contract upon 30 days written notice to the seller.
11. The laws of the State of West Virginia and the *Legislative Rules* of the Purchasing Division shall govern all rights and duties under the Contract, including without limitation the validity of this Purchase Order/Contract.
12. Any reference to automatic renewal is hereby deleted. The Contract may be renewed only upon mutual written agreement of the parties.
13. **BANKRUPTCY:** In the event the vendor/contractor files for bankruptcy protection, this contract is automatically null and void, and is terminated without further order.
14. **HIPAA Business Associate Addendum -** The West Virginia State Government HIPAA Business Associate Addendum (BAA), approved by the Attorney General, and available online at the Purchasing Division's web site (<http://www.state.wv.us/admin/purchase/vrc/hipaa.htm>) is hereby made part of the agreement. Provided that, the Agency meets the definition of a Covered Entity (45 CFR §160.103) and will be disclosing Protected Health Information (45 CFR §160.103) to the vendor.

INSTRUCTIONS TO BIDDERS

1. Use the quotation forms provided by the Purchasing Division.
2. **SPECIFICATIONS:** Items offered must be in compliance with the specifications. Any deviation from the specifications must be clearly indicated by the bidder. Alternates offered by the bidder as **EQUAL** to the specifications must be clearly defined. A bidder offering an alternate should attach complete specifications and literature to the bid. The Purchasing Division may waive minor deviations to specifications.
3. Complete all sections of the quotation form.
4. Unit prices shall prevail in cases of discrepancy.
5. All quotations are considered F O B. destination unless alternate shipping terms are clearly identified in the quotation.
6. **BID SUBMISSION:** All quotations must be delivered by the bidder to the office listed below prior to the date and time of the bid opening. Failure of the bidder to deliver the quotations on time will result in bid disqualifications.

SIGNED BID TO:

Department of Administration
Purchasing Division
2019 Washington Street East
Post Office Box 50130
Charleston, WV 25305-0130

Vendor: DOUGLAS EQUIPMENT

Spending Unit:

Requisition No.: LSH70143

ADDENDUM ACKNOWLEDGEMENT

I hereby acknowledge receipt of the following checked addendum(s) and have made the necessary revisions to my proposal, plans and/or specifications, etc.

Addendum No.'s:

No. 1 ✓

No. 2 ✓

No. 3 _____

No. 4 _____

No. 5 _____

I understand that failure to confirm the receipt of the addendum(s) is cause for rejection of bids.

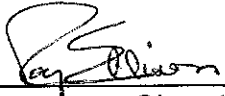
Signature

DOUGLAS EQUIPMENT
Company

2-1-2007
Date



State of West Virginia
 Department of Administration
 Purchasing Division
 2019 Washington Street East
 Post Office Box 50130
 Charleston, WV 25305-0130

Request for Quotation

RFQ NUMBER
LSH70143

PAGE
1

ADDRESS CORRESPONDENCE TO ATTENTION OF
ROBERTA WAGNER
304-558-0067

***709045518 304-327-0149**
DOUGLAS EQUIPMENT
301 NORTH STREET

BLUEFIELD WV 24701-4048

HEALTH AND HUMAN RESOURCES
LAKIN HOSPITAL

1 BATEMAN CIRCLE
LAKIN, WV
25287 304-675-0860

DATE PRINTED 01/25/2007	TERMS OF SALE	SHIP VIA	F.O.B.	FREIGHT TERMS
-----------------------------------	---------------	----------	--------	---------------

BID OPENING DATE: **02/08/2007** BID OPENING TIME **01:30PM**

LINE	QUANTITY	UOP	CAT NO.	ITEM NUMBER	UNIT PRICE	AMOUNT
<p>*****ADDENDUM #2*****</p> <p>1. ANSWERS TO QUESTIONS WHICH WERE SUBMITTED AT THE PREBID CONFERENCE ARE ATTACHED.</p> <p>2. THE BID OPENING DATE IS MOVED TO 2/8/2007 @ 1:30PM.</p> <p>3. ADDENDUM ACKNOWLEDGEMENT IS ATTACHED. THIS DOCUMENT SHOULD BE SIGNED AND RETURNED WITH YOUR BID. FAILURE TO SIGN AND RETURN MAY RESULT IN DISQUALIFICATION OF YOUR BID.</p> <p>*****END OF ADDENDUM #2*****</p>						

SEE REVERSE SIDE FOR TERMS AND CONDITIONS

SIGNATURE <i>Ray Ellison</i>	TELEPHONE (800)962-8618	DATE 2-1-2007
TITLE Bid Specialist	FEIN 550585890	ADDRESS CHANGES TO BE NOTED ABOVE

WHEN RESPONDING TO RFQ, INSERT NAME AND ADDRESS IN SPACE ABOVE LABELED 'VENDOR'

**GENERAL TERMS & CONDITIONS
REQUEST FOR QUOTATION (RFQ) AND REQUEST FOR PROPOSAL (RFP)**

1. Awards will be made in the best interest of the State of West Virginia.
2. The State may accept or reject in part, or in whole, any bid.
3. All quotations are governed by the *West Virginia Code* and the *Legislative Rules* of the Purchasing Division.
4. Prior to any award, the apparent successful vendor must be properly registered with the Purchasing Division and have paid the required \$125.00 registration fee.
5. All services performed or goods delivered under State Purchase Orders/Contracts are to be continued for the term of the Purchase Order/Contract, contingent upon funds being appropriated by the Legislature or otherwise being made available. In the event funds are not appropriated or otherwise available for these services or goods, this Purchase Order/Contract becomes void and of no effect after June 30.
6. Payment may only be made after the delivery and acceptance of goods or services.
7. Interest may be paid for late payment in accordance with the *West Virginia Code*.
8. Vendor preference will be granted upon written request in accordance with the *West Virginia Code*.
9. The State of West Virginia is exempt from federal and state taxes and will not pay or reimburse such taxes.
10. The Director of Purchasing may cancel any Purchase Order/Contract upon 30 days written notice to the seller.
11. The laws of the State of West Virginia and the *Legislative Rules* of the Purchasing Division shall govern all rights and duties under the Contract, including without limitation the validity of this Purchase Order/Contract.
12. Any reference to automatic renewal is hereby deleted. The Contract may be renewed only upon mutual written agreement of the parties.
13. **BANKRUPTCY:** In the event the vendor/contractor files for bankruptcy protection, this contract is automatically null and void, and is terminated without further order.
14. **HIPAA Business Associate Addendum -** The West Virginia State Government HIPAA Business Associate Addendum (BAA), approved by the Attorney General, and available online at the Purchasing Division's web site (<http://www.state.wv.us/admin/purchase/vrc/hipaa.htm>) is hereby made part of the agreement. Provided that, the Agency meets the definition of a Covered Entity (45 CFR §160.103) and will be disclosing Protected Health Information (45 CFR §160.103) to the vendor.

INSTRUCTIONS TO BIDDERS

1. Use the quotation forms provided by the Purchasing Division.
2. **SPECIFICATIONS:** Items offered must be in compliance with the specifications. Any deviation from the specifications must be clearly indicated by the bidder. Alternates offered by the bidder as **EQUAL** to the specifications must be clearly defined. A bidder offering an alternate should attach complete specifications and literature to the bid. The Purchasing Division may waive minor deviations to specifications.
3. Complete all sections of the quotation form.
4. Unit prices shall prevail in cases of discrepancy.
5. All quotations are considered F.O.B. destination unless alternate shipping terms are clearly identified in the quotation.
6. **BID SUBMISSION:** All quotations must be delivered by the bidder to the office listed below prior to the date and time of the bid opening. Failure of the bidder to deliver the quotations on time will result in bid disqualifications.

SIGNED BID TO:

Department of Administration
Purchasing Division
2019 Washington Street East
Post Office Box 50130
Charleston, WV 25305-0130

1. GENERAL INFORMATION:**Change the following item in Part 1.1**

1. Hobart "or equal" Model CRS66A commercial dishwashing unit with a 30 KW pressure less booster heater, stainless steel vent hoods with vent stack and locking damper, and electric blower-dryer or equal.

To read:

1. Hobart "or equal" Model CRS66A commercial dishwashing unit to include a 30 KW pressure less booster heater and controls are to be top mounted. 15 KW electric immersion heater, factory wired with positive low water protection controlled by solid-state thermostat. Conveyor equipped with dual side pawls and ball detent clutch drive system to prevent conveyor or drive motor damage in the event of rack obstruction.

3. SCOPE OF WORK:**Change from:**

- 3.2 The objective of this RFQ to obtain a contract for the delivery, purchase, set up installation of a Hobart Model CRS66A Dishwasher "or equal". The dishwasher is a fully automatic, right to left operation, 202 racks per hour, top mounted controls, stainless steel frame (chamber 6" higher than standard), stainless steel anti-clogging fixed wash arms, automatic fill, fixed pump intake screen, with a 3 phase, 10.28 amp, 208/240 volt motor.

To read:

- 3.2 The objective of this RFQ to obtain a contract for the delivery, purchase, set up installation of a Hobart Model CRS66A Dishwasher "or equal". The dishwasher is a fully automatic, right to left operation, 202 racks per hour, top mounted controls, stainless steel frame (chamber 6" higher than standard), stainless steel anti-clogging removable (without tools) upper and lower wash and pre-wash arms, automatic fill, fixed pump intake screen, with a 3 phase, 10 amp, 208/240 volt motor.

Change from:

- 3.2.2 Contractor shall furnish and install a stainless steel vent hood (4 X 16) with vent stack and locking-type damper designed to fit either end of the dishwasher.

To read:

- 3.2.2 Contractor shall furnish and install a stainless steel vent hood (4 X 16) with vent stack and locking-type damper on both the loading and unloading ends of the dishwasher.

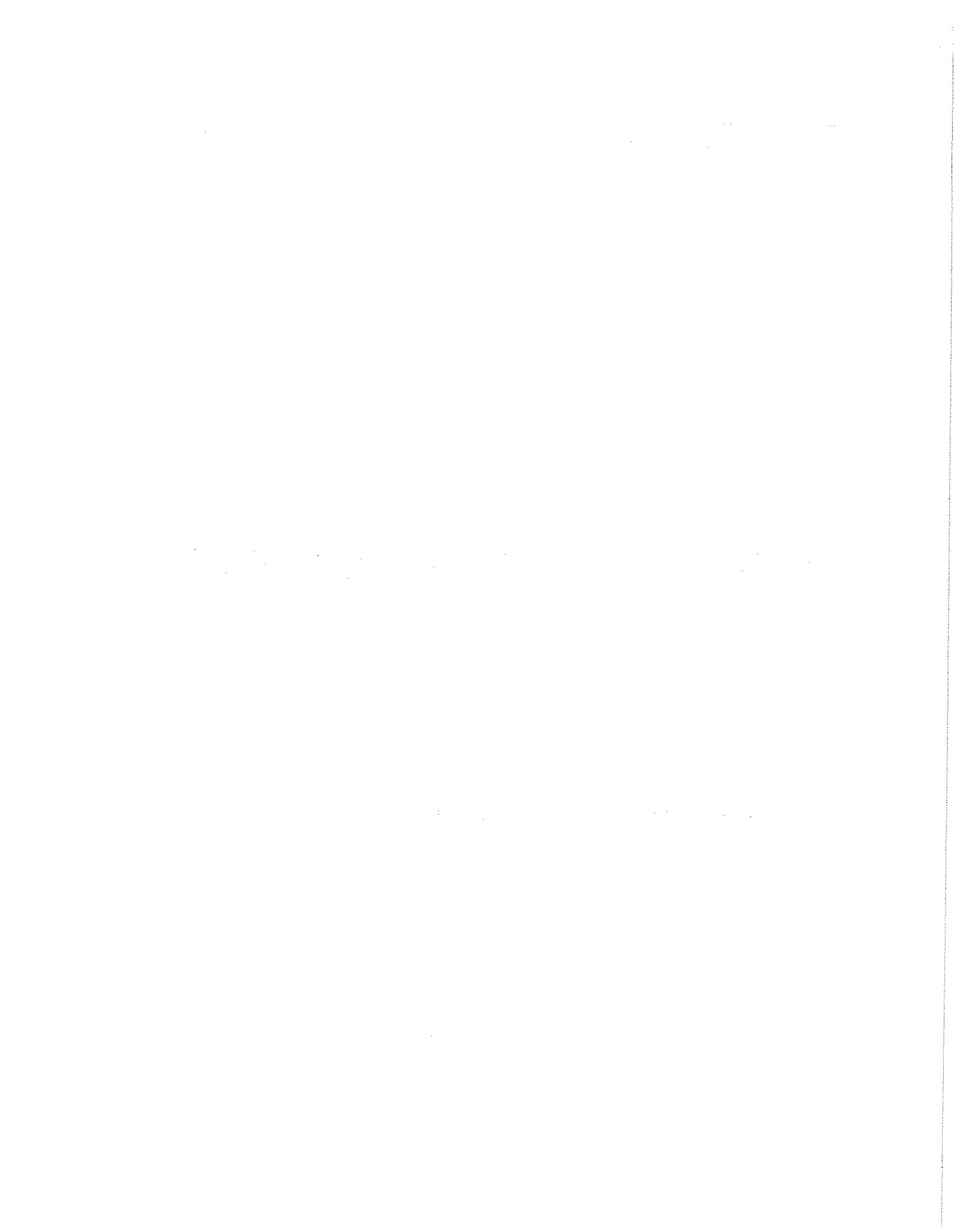

Delete entirely:

- 3.2.4 Contractor shall provide and install an electric blower dryer (3-phase only).

Change from:

- 3.2.5 Contractor shall provide and install a stainless steel booster heater, 30 KW minimum.

To read:

- 3.2.5 Contractor shall provide and install a top mounted stainless steel 30 KW booster heater with controls.

Change from:

- 3.3 Contractor shall furnish and install a Hobart "or equal" Dishwasher Disposer Model Number FD3/300-1, with 3 HP motor, aluminum housing, adjustable feet, 208/240 volts, 3 phase.

To read:

- 3.3 Contractor shall furnish and install a Hobart "or equal" Dishwasher Disposer (including control panel) Model Number FD3/300-1, with 3 HP motor, aluminum housing, adjustable feet, 208/240 volts, 3 phase.

Change from:

- 3.6 Contractor shall furnish and install soiled dish table sized and shaped per the space dedicated for this component. Unit shall be constructed with 300 series 14-gauge stainless steel top. Top has 10" backsplash at rear with 45 degrees turn back at top. Unit shall be sloped toward dishwasher. Table shall be built to match up with Side Loader and include a Pre-rinse sink welded in ring, scrap trough 6" wide X 54" long flowing into sink.

To read:

- 3.6 Contractor shall furnish and install soiled dish table sized and shaped for the space dedicated for this component. Unit shall be constructed of 300 series 14-gauge stainless steel top with 10" back splash at rear of table with 45-degree turn back. Dish washer table shall be built to match up with side loader, left side pre-rinse sink 6" x 54" scrap trough, right side double bowl pre-soak sink and fit the present pass through window for soiled dishes entering the soiled dish table.

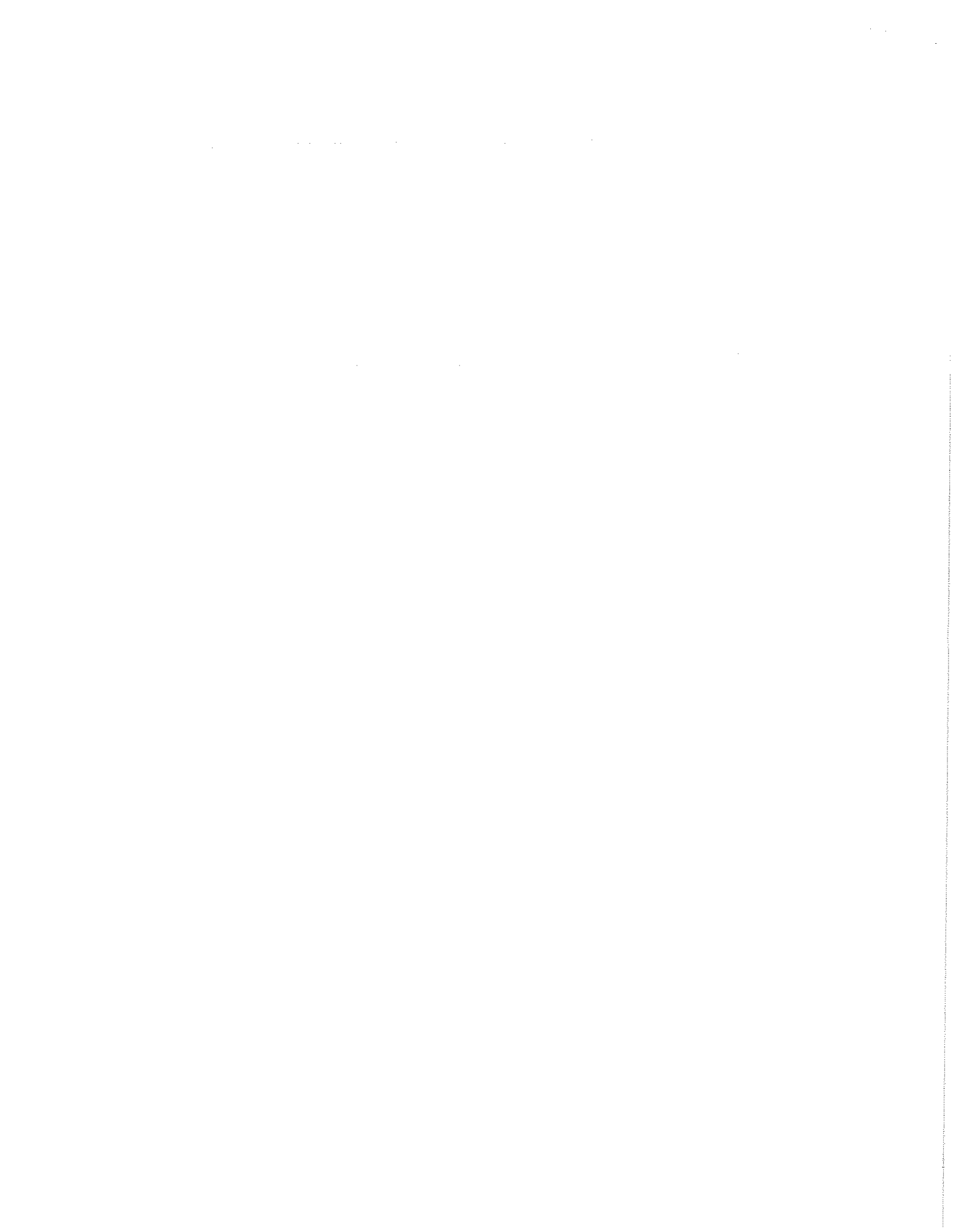

Change from:

- 3.7 Contractor shall furnish and install an easy install pre rinse unit, wall mounted, base faucet with spring check cartridges and level handles, 1" long NPT male inlets, 15" overhang, 18" riser, and a flexible hose.

To read:

- 3.7 Contractor shall furnish and install a pre-rinse wall mounted unit and a base mounted unit.
- a. Base mounted unit shall have a swivel faucet with lever handles 1" long N.P.T. male inlets 15" overhang, 18" riser installed at the right side of double bowl pre-soak sink.
 - b. Wall mounted unit shall have a flexible hose with squeeze on-off nozzle and mounted at the left side of pre-rinse sink.

END OF ADDENDUM #2

Request for Proposal No.

PLEASE PRINT

Date: 05/03/2006

* PLEASE BE SURE TO PRINT LEGIBLY - IF POSSIBLE, LEAVE A BUSINESS CARD-

FIRM & REPRESENTATIVE NAME	MAILING ADDRESS	TELEPHONE & FAX NUMBERS
Company: <u>Douglas Equipment</u>	<u>301 North Street</u>	PHONE <u>304 327-0149</u>
Rep: <u>Larry Douglas</u>	<u>Bluetield, WV</u>	TOLL FREE <u>800-962-8618</u>
Email Address: <u>Larry@DouglasEquipment.com</u>		FAX <u>304-325-3548</u>
Company: <u>ELCO Mech Cont</u>	<u>1510 Coonskin Dr</u>	PHONE <u>3043460546</u>
Rep: <u>D L ELLIS</u>	<u>Chas. WU 25312</u>	TOLL FREE <u>1-888 617 9652</u>
Email Address: _____		FAX <u>304 3460548</u>
Company: _____		PHONE _____
Rep: _____		TOLL FREE _____
Email Address: _____		FAX _____
Company: _____		PHONE _____
Rep: _____		TOLL FREE _____
Email Address: _____		FAX _____
Company: _____	<u>OFF. OF DIR. PURCHASING</u>	PHONE _____
Rep: _____	<u>207 JAN 11 AM 11:45</u>	TOLL FREE _____
Email Address: _____		FAX _____

RECEIVED

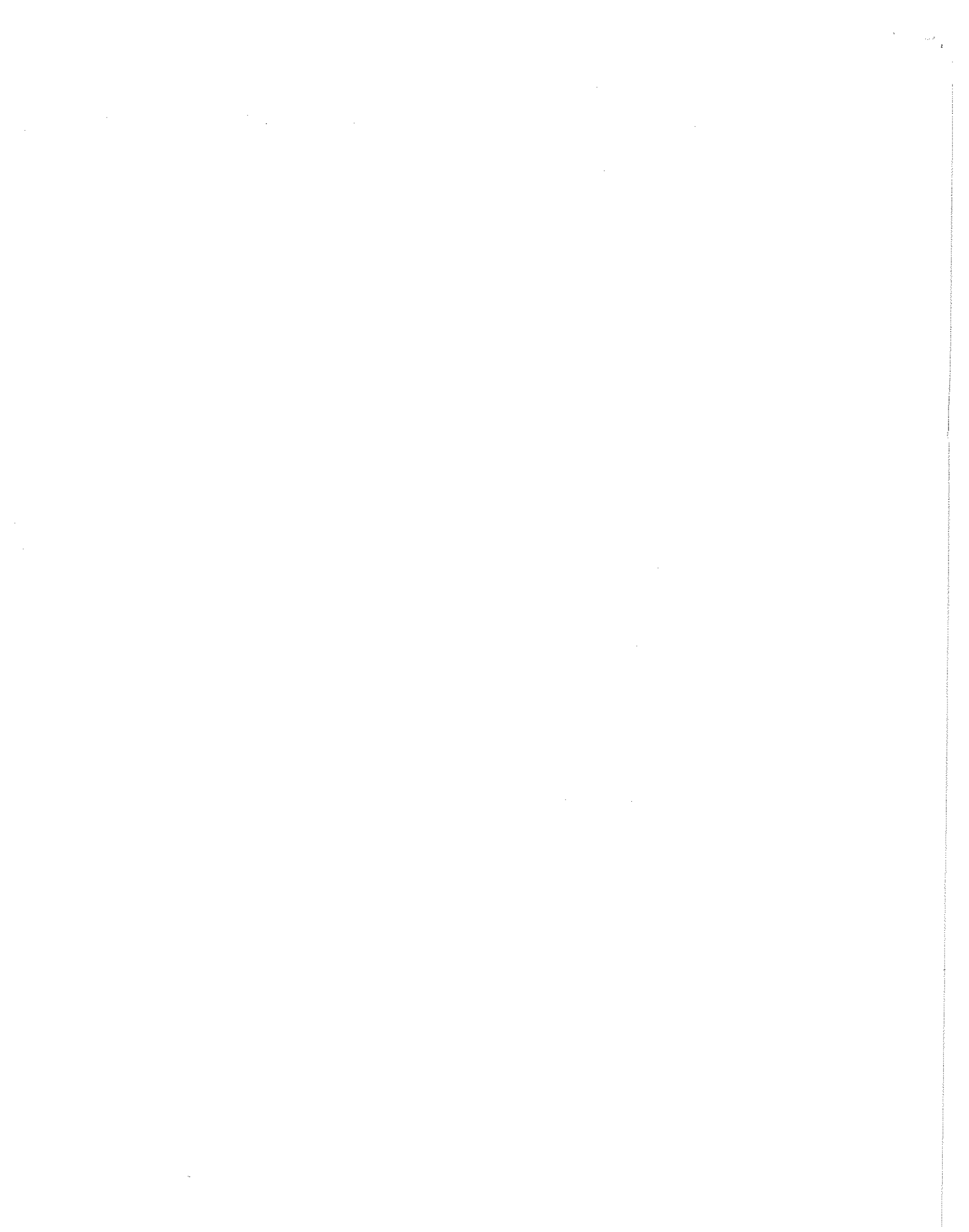

PURCHASING CONTINUATION SHEET

Buyer: RW-22	Page 6	Req. or P.O. No.: LSH70143
Spending Unit: Lakin Hospital		

Vendor:

Requisition No.: LSH70143

ADDENDUM ACKNOWLEDGEMENT

I hereby acknowledge receipt of the following checked addendum(s) and have made the necessary revisions to my proposal, plans and/or specifications, etc.

Addendum No.'s:

- No. 1 ✓
- No. 2 ✓
- No. 3 _____
- No. 4 _____
- No. 5 _____

I understand that failure to confirm the receipt of the addendum(s) may be cause for rejection of bids.

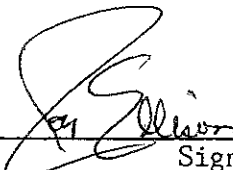
Signature

Douglas Equipment
Company

2-1-2007
Date

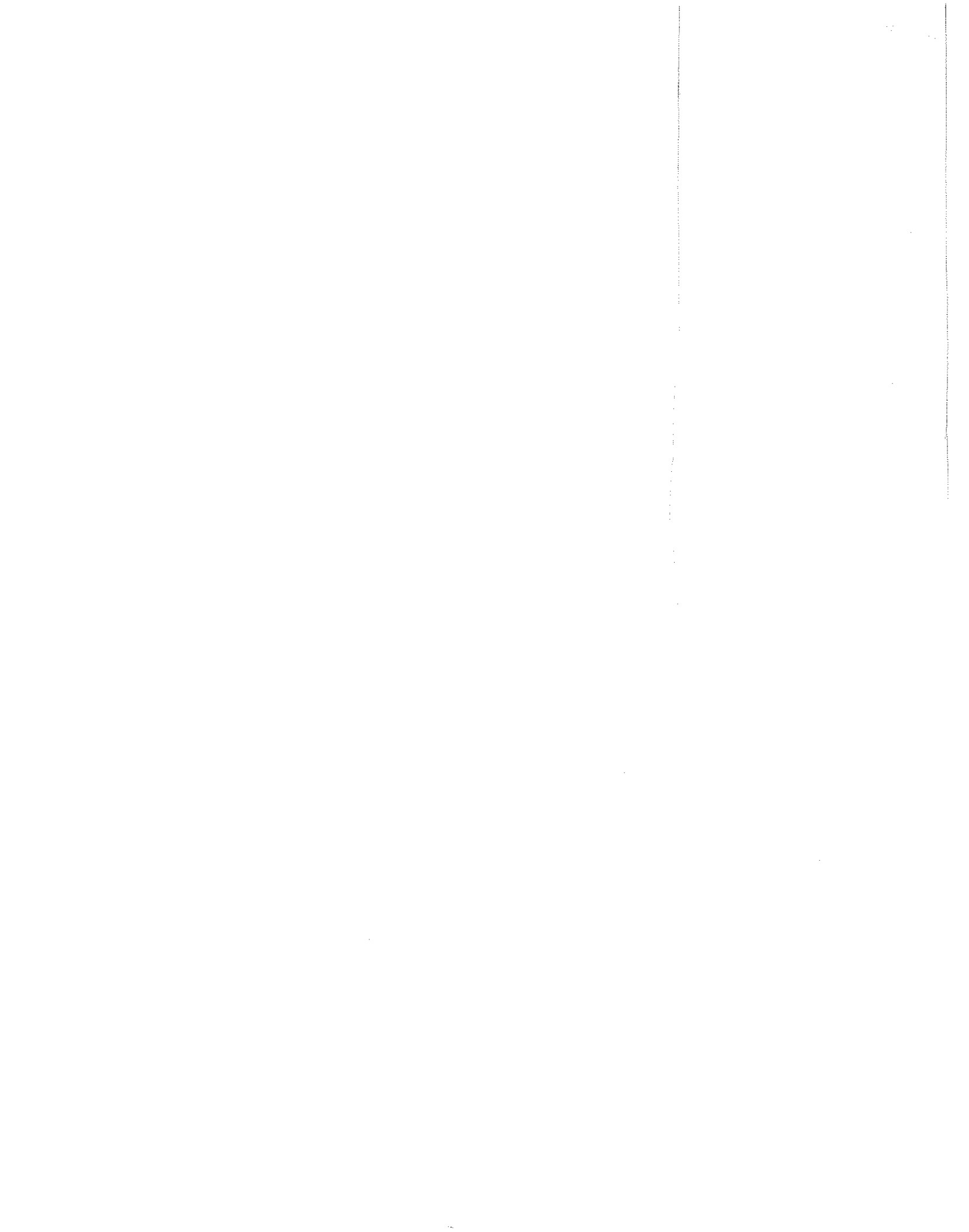

LAKIN HOSPITAL
RFQ # LSH70143

PROPOSAL FOR DISHROOM

KITCHEN EQUIPMENT CONTRACTOR:

DOUGLAS EQUIPMENT
301 NORTH STREET
BLUEFIELD, WV 24701

(800) 962-8618 TOLL FREE
(304) 327-0149 PHONE
(304) 325-3848 FAX

ROY@DOUGLASEQUIPMENT.US

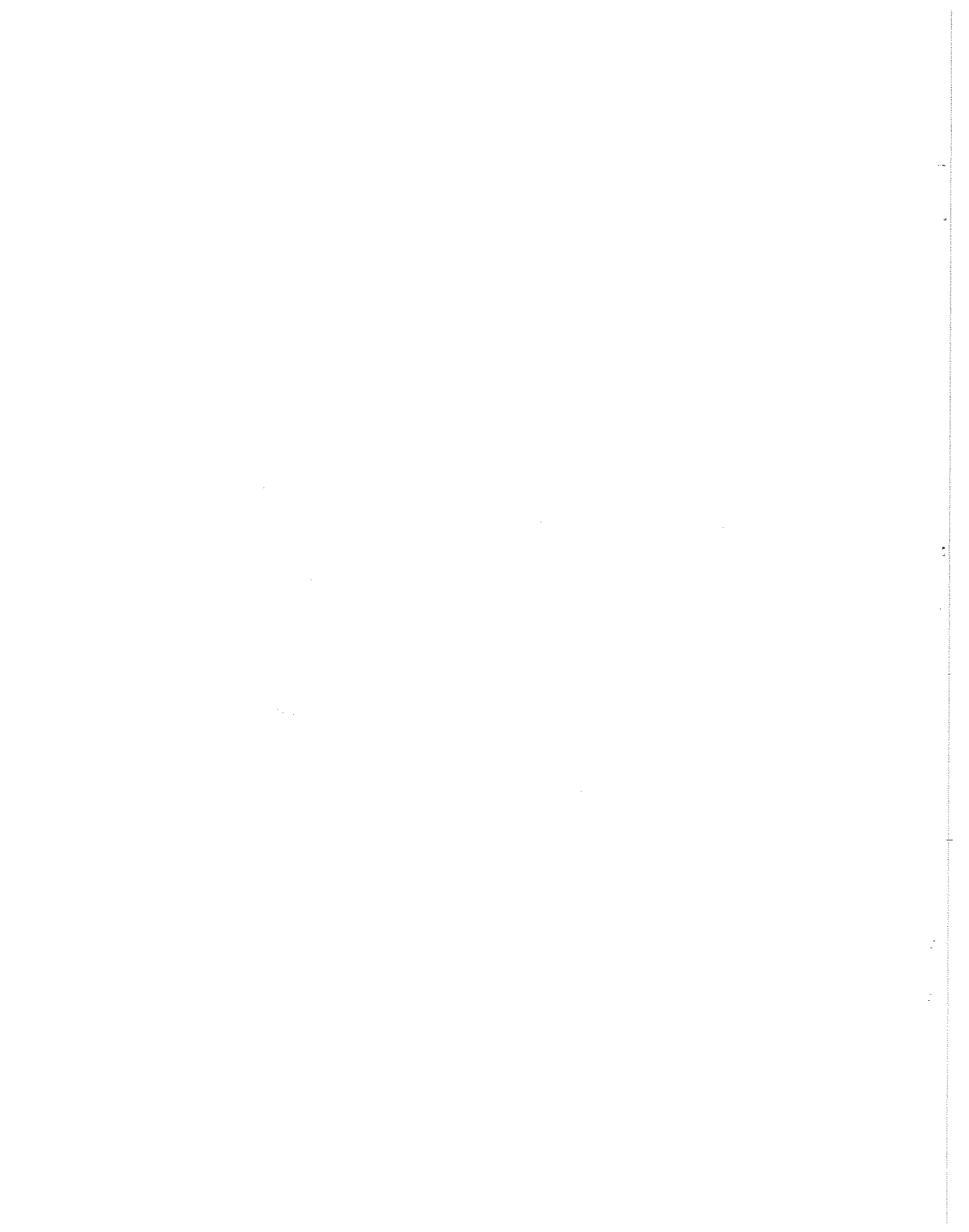

Lakin Hospital Dishroom Layout

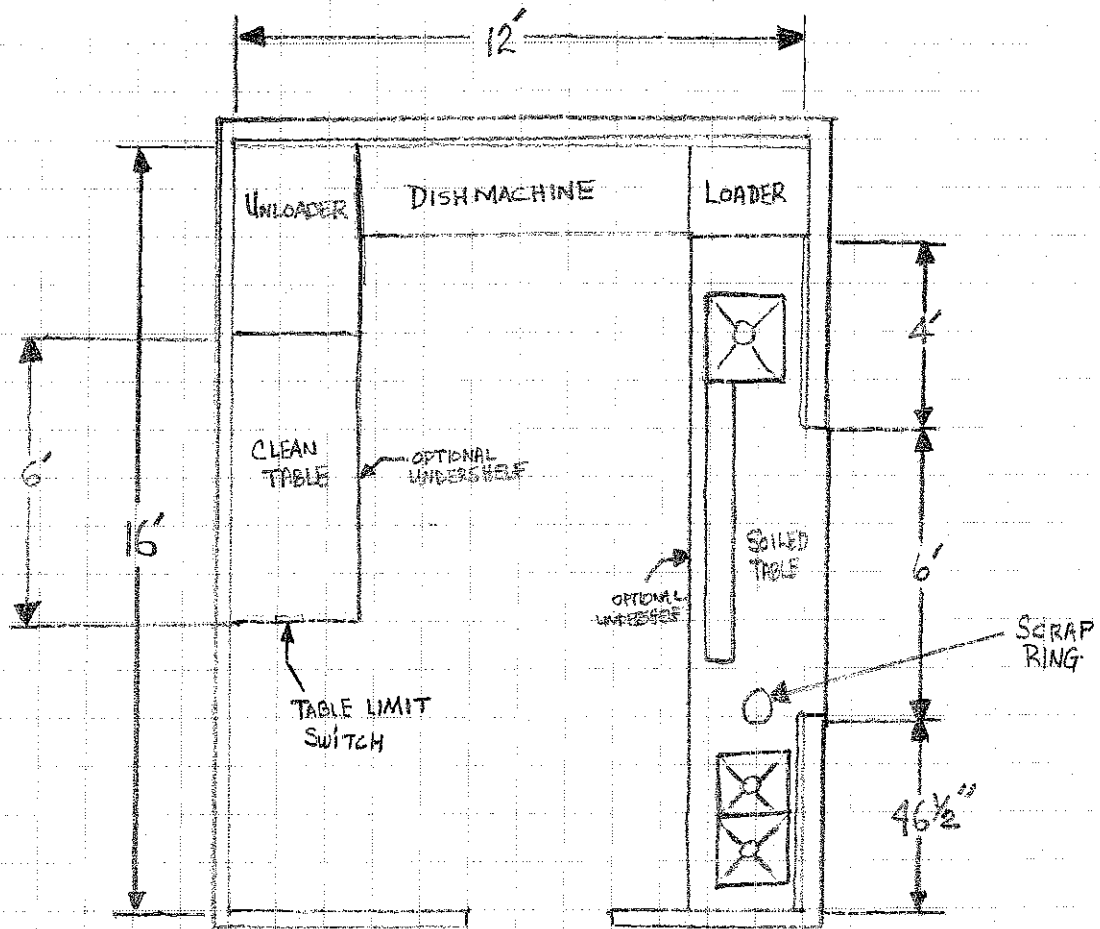

DOUGLAS EQUIPMENT

BLUEFIELD, WV 24701
 (304) 327-0149
 FAX (304) 325-3848

JOB LAKIN HOSPITAL RFQ # LSH70143

SHEET NO 1 OF 1

CALCULATED BY R. ELLISON DATE 1-31-2007

CHECKED BY [Signature] DATE 1-31-2007

SCALE _____

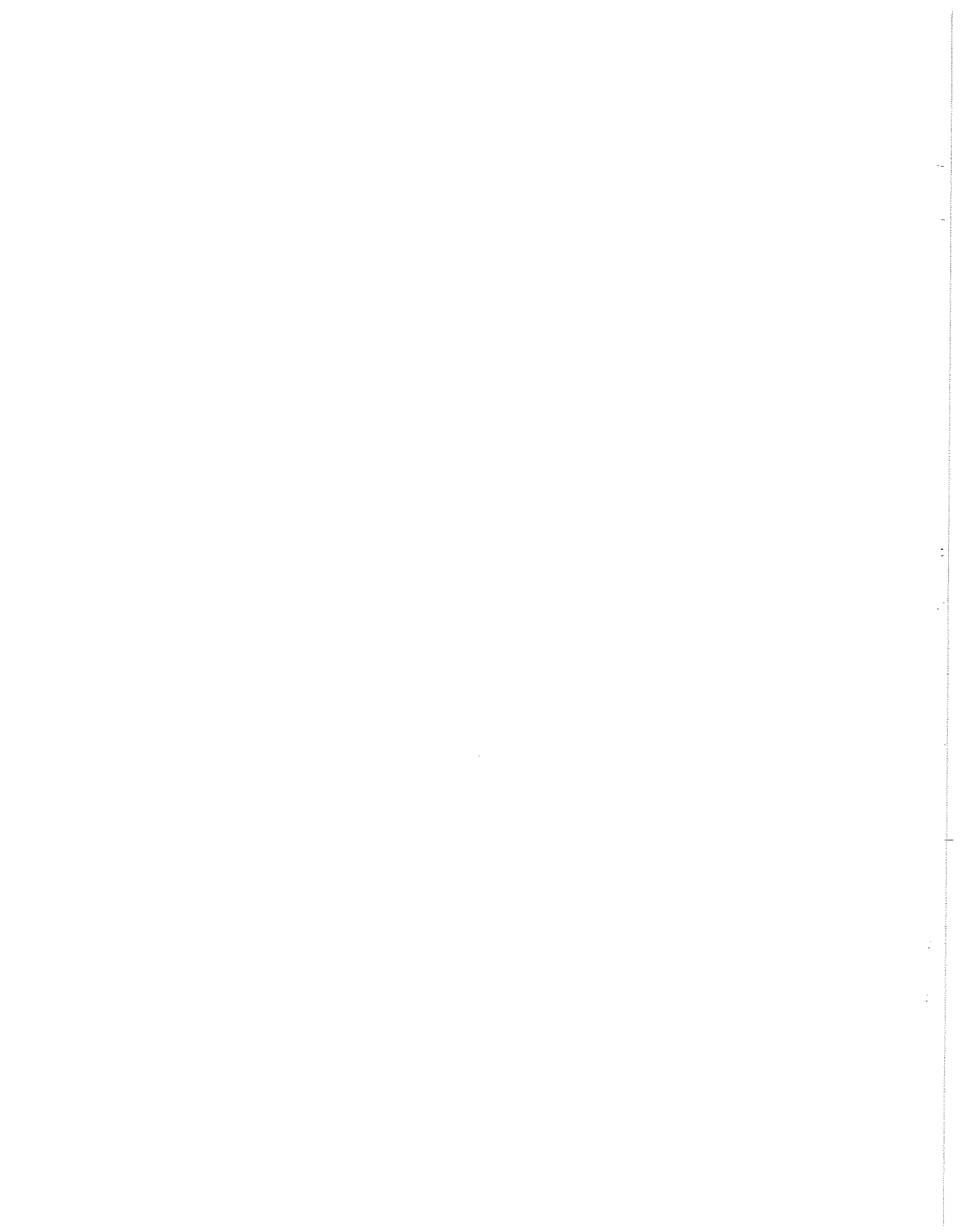

2/2/2007

Quotation

To: Health and Human Resources
 Lakin Hospital RFQ number: LSH70143
 1 Bateman Circle
 Lakin, WV 25287

From: Douglas Equipment
 Roy Ellison
 301 North St.
 Bluefield, WV 24701-4048

Phone: (304) 327-0149

Item	Qty	Description	Sell Each	Sell Total
1	1	ea DISHWASHER, CONVEYOR TYPE Insinger Model No 66-4 RPW Class: 85 Admiral Dishwasher, Conveyor Type, high temperature, no booster, single tank w/power wash and pre-wash section, CrossFire® wash system, approx. 217 racks/hour cap., s/s frame, legs & feet, elec. immersion or steam injector tank heat	48,444 00	48,444 00
	1	ea 208v, 3 ph		
	1	ea Electric immersion tank heat		
	1	ea Rack limit switch		
	1	ea Vent collars w/dampers (each)		
	1	ea Extra high hood		
	1	ea SIDE LOADER Power Side Loader, for conveyor machines, stainless steel frame, legs and feet		
	1	ea UNLOADER Power Unloader, for conveyor machines, stainless steel construction		
	1	ea Southern Fabco PLDCT Custom fabricated vent duct with vent stack and locking damper on both loading and unloading ends of dishwasher. Vent to be tied into existing ductwork and to be used in conjunction with existing exhaust fan. Weight: 1275 lbs. total		
2	1	ea BOOSTER HEATER, ELECTRIC Hatco Model No. C-27 Class: 85 Compact Booster Heater, Electric, 6-gallon storage capacity, electric operation, 27-KW, stainless steel front, Castone tank		
	1	ea NOTE: Includes 24/7 parts & service assistance, call 800-558-0607		
	1	ea 208v, 3-ph Weight: 142 lbs. total		
3	1	ea DISPOSER InSinkErator Model No SS-300-7-CC101 Class: UPS Complete Disposer Package, sink mount system, 6 5/8" diameter inlet, with #7 collar adaptor for sink installation, 3 HP motor, s/s constr'n, includes syphon breaker, solenoid valve, flow control valve, removable splash baffle, stainless steel sink stopper, programmable CC101 control panel, auto reversing, timed run, post flush		
	1	ea Standard height disposer body		
	1	ea -25, 208v, 3 ph Weight: 158 lbs. total		

Health and Human Resources

Item	Qty	Description	Sell Each	Sell Total
4	1	ea PRE-RINSE UNIT T & S Brass Model No. B-0133-01 EasyInstall Pre-Rinse Unit, wall mount base faucet w/spring check cartridges & lever handles, 2" dia flanges w/1/2" NPT female eccentric flanged inlets, add-on faucet w/14" swing nozzle, 41-3/8"H, 18" riser, B-0107 spray valve, B-0044-H flex s/s hose		
	1	ea B-0109-01 wall bracket, 6"		
	1	ea 00CC Union Coupling Inlets, male 1/2" IPS inlet, 1" long Weight: 15.333 lbs. total		
5	1	ea PRE-RINSE UNIT T & S Brass Model No. B-0113-B EasyInstall Pre-Rinse Unit, spring action gooseneck, single hole base faucet, 18" flex. s/s supply lines w/comp. fittings for 5/8" OD copper tubing, 45" h, 14" overhang, 19-3/8" clear, 24" riser, spray valve (B-0107), s/s hose (B-0044-H) and 6" wall bracket Weight: 13 lbs. total		
6	1	ea CUSTOM FABRICATION Southern Fabco Model No. CLNTBLE Clean dishtable with 10" backsplash: 30" wide x 72" 14 gauge 304 stainless, 1 5/8" stainless legs with adjustable feet. Rack limit switch on end of clean table to prevent damage, jamming machine, or rack obstruction.		
	1	ea US Optional 60" stainless undershelf, for increased storage capacity.	238.00	<optional>
7	1	ea CUSTOM FABRICATION Southern Fabco Model No. STBLE Custom Stainless Soiled Dishtable: 30" Wide x 166 1/2" Long with 10" backsplash. 14 gauge 304 stainless top, 1 5/8" stainless legs and bracing Includes adj (2) wash sinks 16" x 20" x 12" deep. Pass thru area with Marine edge approx 8" x 72". Includes Scrapping trough approx 70" long x 6", sloped to prerinse sink (1) Control (1) prerinse sink 20" x 20" x 8" deep w/ (1) weld ring for disposer. Also includes scrap ring (scrap block).		
	1	ea US Optional 72" stainless undershelf, for increased storage capacity. (Under trough section).	325.00	<optional>
***		PRICING INCLUDES FREIGHT, APPLICABLE BID BOND(S), AND PREVAILING WAGE RATES FOR ALL LABOR. PROOF OF INSURANCE AND COPY OF CONTRACTORS LICENSE AVAILABLE UPON REQUEST.		
		Total		48,444.00
		Grand Total		48,444.00

ADMIRAL 66-4 SINGLE TANK CONVEYOR DISHWASHER WITH RECIRCULATING PREWASH

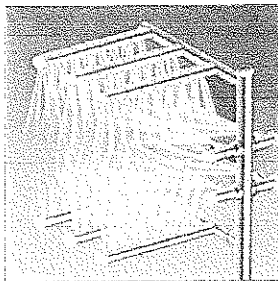
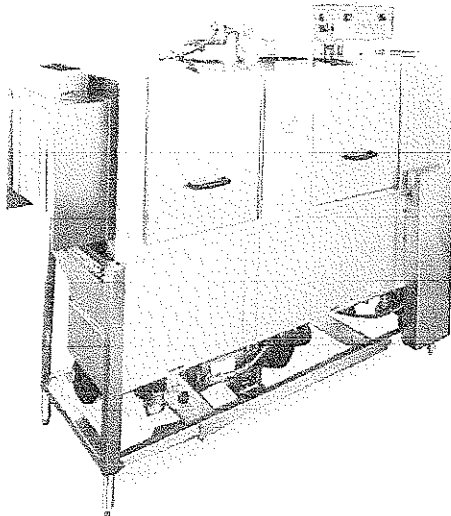

Patented CrossFire® Wash System creates a fan shaped spray to clean ware thoroughly

DESIGN

Automatic conveyor, rack type single tank dishwasher with recirculating prewash and wash and fresh water final rinse. Capacity is 233 - 20"X20" racks per hour, or 5,825 dishes per hour with a conveyor speed of 6.4 ft. per minute. Designed for left or right hand conveyor travel, as specified.

STANDARD EQUIPMENT

- Exclusive CrossFire® Wash System (patented)
- Tank heat: 15 KW electric immersion heater or steam injector
- Capillary thermometers for prewash and wash
- In-line thermometer for final rinse
- Vacuum breaker on all incoming water lines
- S/S vestibules
- Manifold cleanout brush
- Inspection doors
- S/S frame, legs and feet
- S/S front enclosure panel
- Automatic tank fill
- Low water protection
- Single point electrical connection: motor, controls, and heater
- Detergent connection provision
- Elevated top mounted NEMA 12 control panel
- Easily-cleaned crowned hood top
- Simplified scrap screen design
- Door safety switches
- Standard frame drip proof motors
- Energy saver
- Detergent saver
- Override switch for de-liming
- SureFire™ Start-Up and Check-Out Service
- Ventilation fan connection provision
- End caps/pipe plugs secured to prevent loss
- Color-coded curtains
- Timing belt conveyor drive

OPTIONAL ACCESSORY EQUIPMENT

- Pressure reduction valve and line strainer
- Stainless steel steam coil tank heat
- Infrared tank heat—50,000 BTU natural gas or propane
- Steam booster
- Electric booster
- Vent and adjustable damper controls
- Security package
- Totally enclosed motors
- Rack limit switch
- Chemical sanitizer injector package for low temperature operations
- Insulated hood and doors
- Power loader
- Power unloader
- Door activated drain closers
- Plastic 20"X20" racks (plate or silver)



CSI - 11400

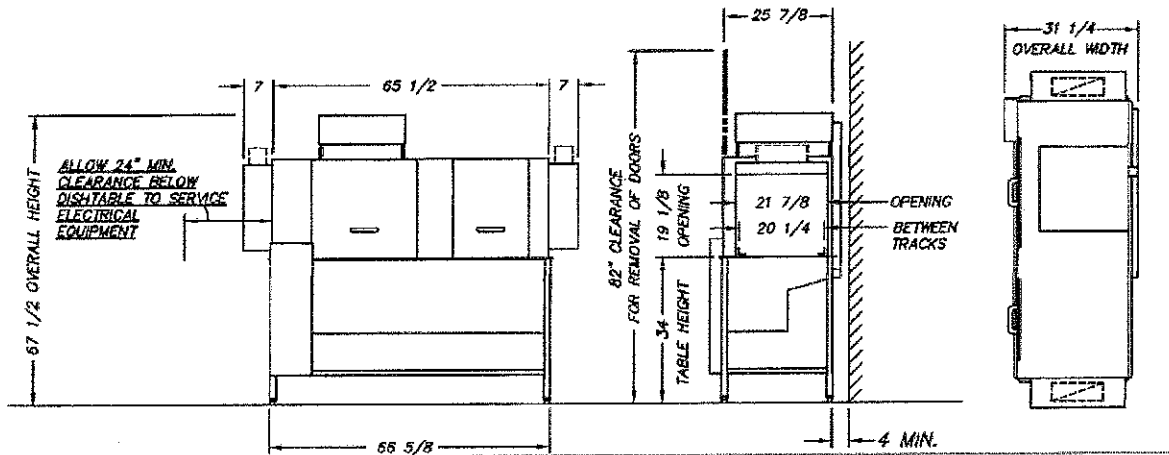

Note: For all rough in connections see Installation and Layout Detail Drawing.

SPECIFICATIONS

CONSTRUCTION - Hood and tank constructed of 16 gauge type 304 S/S. Hood of all welded seamless construction. S/S frame, legs, and feet. All internal castings are non-corrosive nickel alloy, bronze or S/S.

DOORS - Two extra large die formed type 304 S/S front inspection doors riding in all S/S channels. No plastic or nylon sleeves or liners used. Two intermediate S/S door safety stops on each door.

CONVEYOR - One S/S roller chain conveyor, with rack driving lugs every sixth link, running along the front of the machine. 12 free spinning rollers placed along the back wall of the machine. Conveyor accommodates all standard 20" racks. Conveyor drive system includes direct drive gear motor with frictionless, trouble-free clutch system, spring-loaded and automatically re-engaging. Racks conveyed automatically through washing and rinsing systems, powered by an independent 1/15 HP drive motor.

PUMPS - Centrifugal type "packless" pump with brass petcock drain. Construction includes ceramic seal and a balanced cast impeller on a precision ground stainless steel shaft. All working parts mounted as an assembly and removable as a unit without disturbing pump housing. Two HP wash motor and 1/2 HP prewash motor: standard horizontal C-face frame, drip proof, internally cooled with ball-bearing construction.

CONTROLS - Top mounted NEMA 12 control enclosure, with 3.5 inch air gap between hood and enclosure, housing motor overload protection, contactors, transformers, and all other dishwasher controls. All controls safe low voltage 24 VAC.

ENERGY SAVER - Rack actuated lever automatically operates the final rinse solenoid only when a rack passes, saving water and energy. The lever also activates an adjustable timer control. If no ware passes during the set time, the machine shuts down.

SPRAY SYSTEM - Spray arms made of type 304 stainless steel pipe. Spray assemblies removable without the use of tools.

PREWASH - One manifold above and one manifold below, each with 3 high pressure cleaning nozzles.

WASH - Upper and lower manifolds with CrossFire® System (patented). One manifold above with 3 power wash arms, each with 5 high pressure cleaning slots and one manifold below with 4 power wash arms, each with 7 high pressure cleaning slots. The slots are precision milled for water control producing a fan spray. Wash arms are fillet welded to the S/S manifold. The CrossFire® System provides 4 horizontally spraying high pressure nozzles.

FINAL RINSE - Three nozzles above and four nozzles below threaded into S/S schedule 40 pipes. Nozzle assemblies produce a fan spray reducing water consumption, maximizing heat retention.

DRAINS - Drain valves externally controlled. Overflow assembly with skimmer cap is removable without use of tools for drain line inspection. Heaters protected by low water level control.

*Note—Exhaust requirements are for part leg connections only. For hood type, CFM requirements vary, consult hood manufacturer for specific sizing.

Capacity per hour	Tank capacity	Motor size	Electric usage	Steam consumption at 20 psi min.	Gas consumption	
233 racks 5,825 dishes 225-500 meals	9 gals. (prewash) 19 gals. (wash) 17 gals. (prewash-gas) 37 gals. (wash-gas)	2 hp (wash) 1/2 hp (prewash) 1/15 hp (conveyor)	15 kw tank 15 kw rem booster 40° rise 27 kw rem booster 70° rise	54 lbs./hr tank 52 lbs./hr booster 40° rise 91 lbs./hr booster 70° rise	50,000 BTUH 49 CFH nat. gas 20 CFH propane	
Final rinse peak flow at 20 psi min.	Final rinse consumption at 20 psi min.	*Exhaust requirements	Peak rate drain flow	Current draw amps	Steam Gas w/o booster	Electric w/o booster
3.3 gals./min.	147 gals./hr. 0.63 gals./rack	350 CFM Load 350 CFM Unload	14 gals./min.	208/3/60 10.9	11.6	52.5
				240/1/60 17.8	17.8	80.3
				240/3/60 10.0	10.7	46.1
				380/3/50 6.0	6.4	28.8
				480/3/60 5.0	5.3	23.0
Shipping weight	Installation distance from vertical combustible service					
800 lbs.	2"					

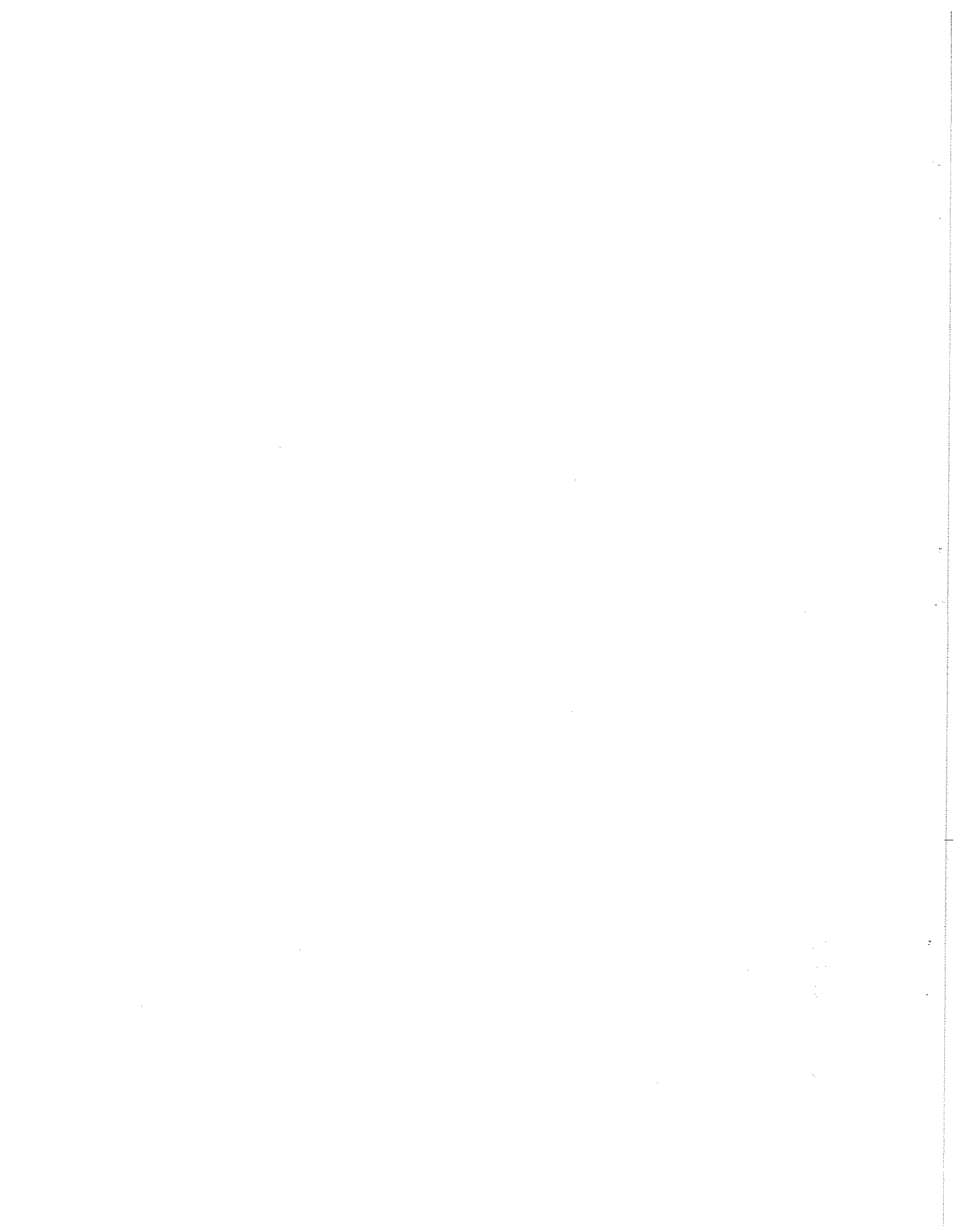

POWER LOADER & UNLOADER

CSI - 11400

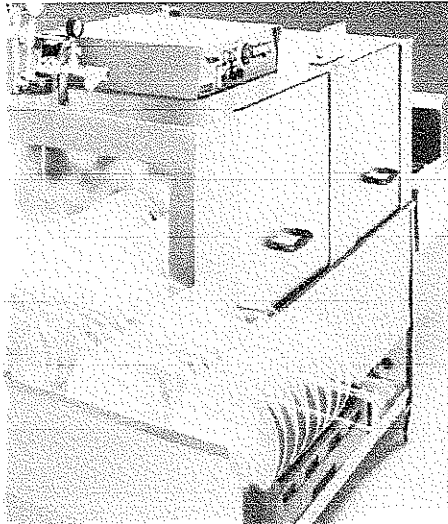

DESIGN

The Insinger Power Loader and Unloader are unique, cost saving accessories for use with Insinger rack conveyor warewashing systems. Each unit is driven by a dedicated motor, independent of the warewasher.

Since the operator can load and unload at a 90° angle, these units provide an efficient dishroom design that would not be possible with a straight through design. The space and labor cost savings combined with Insinger quality keep your dishroom operating at peak efficiency.

The Power Loader and Unloader are available on Insinger's complete line of rack conveyor machines.

Current draw amps	Load	Unload
208/3/60	1.7	1.7
220/1/60	3.4	4.1
240/3/60	1.5	1.6
380/3/50	0.9	1.0
480/3/60	0.8	0.9

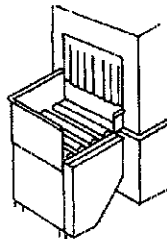
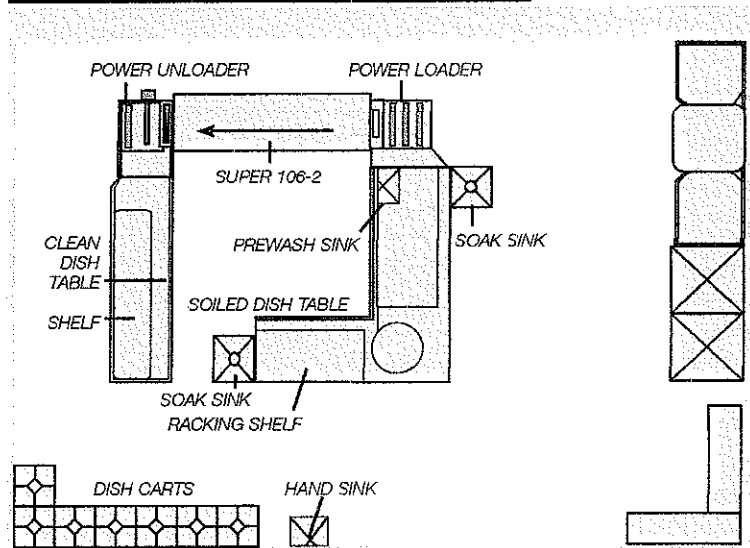
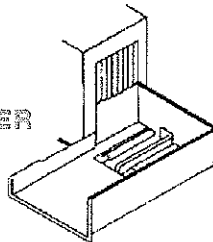
 POWER
LOADER

 POWER
UNLOADER

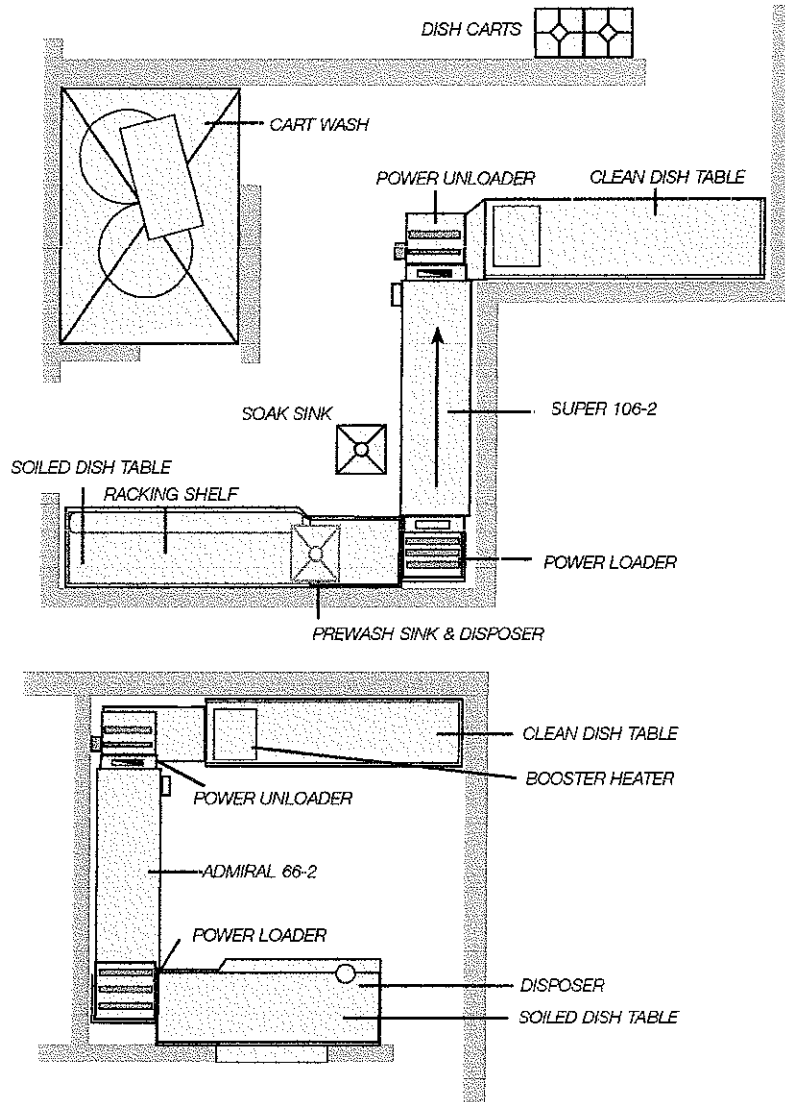

Insinger® POWER LOADER/UNLOADER

CSI - 11400



- ◆ May be used independently or in combination with each other.
- ◆ Unique design allows for use around columns and in difficult to design areas.
- ◆ Eliminates cumbersome, space consuming curved rollers.
- ◆ Adaptable to all Insinger rack conveyor machines.
- ◆ Innovative design gives flexibility of right-to-left or left-to-right application.
- ◆ Can add several feet of work space at the clean end by utilizing an additional wall.
- ◆ Can give you the option of using a small rack conveyor instead of a single tank corner style machine.
- ◆ Optional limit switch at end of clean table shuts down conveyor when clean racks accumulate

SPECIFICATIONS

CAPACITY - Capacity varies with the size of the dishwasher used. Maximum capacity is 330 20"x20" racks per hour. Will accommodate 22" long trays in an open end rack.

DESIGN - Can be used in both right-to-left and left-to-right operations. Loader and Unloader can each be used independently or in combination with each other.

CONSTRUCTION - Pan constructed of 16 gauge type 304 18-8 stainless steel with all welded construction. Both Loader and Unloader are furnished with a 10" backsplash and a 1 1/2" rim roll. All moving parts with the exception of the pushers and rollers are covered with a stainless steel panel.

OPERATION

Power Loader - 3 powered rollers with an operating speed of 10 surface feet per minute. Rollers powered by a chain drive operated by a 1/3 HP motor and reduction gear combination.

Power Unloader - 3 powered rollers with an operating speed of 10 surface feet per minute plus a simultaneously timed rack ejector. Rollers powered by a chain drive operated by a 1/15 HP motor. Ejector powered by a 1/4 HP motor through a reduction gear and sprockets protected by a safety clutch to deliver a stroke of 15-20 feet per minute. Stroke is fast enough to push the clean dish rack out and reposition the ejector to receive the next rack as it exits the dishwasher.

MOTORS - 1/3 HP motor furnished with Power Loader. 1/4 HP and 1/15 HP motors furnished with Power Unloader. Motors are standard frame, internally fan-cooled with ball bearing construction.

DRAIN - Drain for Unloader is connected to machine.

ITEM#



COMPACT ELECTRIC BOOSTER WATER HEATERS
 Models C-4, -5, -6, -7, -9, -12, -13, -15, -17, -18, -24, -27, -30, -36, -39, -45, -54, -57

The Hatco Compact Electric Booster Water Heater provides all the 180°F (82°C) final rinse water required to sanitize and flash-dry dishes and flatware.

FLEXIBILITY

The space saving Compact is easy to install next to the dishwasher with slide brackets or on 6" (152 mm) legs. The storage capacity is 6 gallons (23 liters).

QUALITY

The following features assure the finest performance for years to come:

- All models include a Castone® lined tank with a 10-year limited warranty.
- Features include a temperature/pressure relief valve, a pressure reducing valve, two temperature/pressure gauges, a high-temperature limit control, pilot indicator light, on-off switch, and a low-water cut-off to prevent element burnout due to a low water condition.
- Available with slide brackets for mounting under a dishtable.
- Each booster has fiberglass insulation to minimize heat loss.
- Hatco electric booster heaters are factory pre-plumbed and pre-wired with calibrated immersion thermostat and high-temperature limit switch.
- A stainless steel front panel and powder-coated silver-gray hammertone body is standard on all Compact models.
- Swing-away front panels with low-water cut-off, control fuses and transformer allow quick access to probes and elements for easier serviceability.

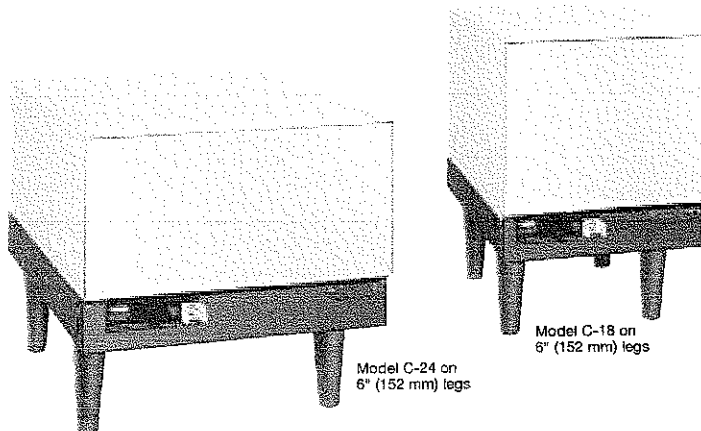

Water Temperature Recovery Table

Compact Model	40°F (22°C) Rise	70°F (39°C) Rise
C-4	40 gph (151 lph)	23 gph (87 lph)
C-5	50 gph (189 lph)	29 gph (110 lph)
C-6	60 gph (227 lph)	34 gph (129 lph)
C-7	70 gph (265 lph)	40 gph (151 lph)
C-9	90 gph (341 lph)	52 gph (197 lph)
C-12	120 gph (454 lph)	69 gph (261 lph)
C-13	135 gph (511 lph)	77 gph (292 lph)
C-15	151 gph (572 lph)	86 gph (326 lph)
C-17	173 gph (655 lph)	99 gph (375 lph)
C-18	181 gph (685 lph)	103 gph (390 lph)
C-24	241 gph (912 lph)	138 gph (522 lph)
C-27	271 gph (1026 lph)	155 gph (587 lph)
C-30	301 gph (1139 lph)	172 gph (651 lph)
C-36	361 gph (1367 lph)	206 gph (780 lph)
C-39	391 gph (1480 lph)	224 gph (848 lph)
C-45	452 gph (1711 lph)	258 gph (977 lph)
C-54	542 gph (2052 lph)	310 gph (1174 lph)
C-57	573 gph (2169 lph)	326 gph (1234 lph)

WATER QUALITY REQUIREMENTS

Incoming water in excess of 3.0 grains of hardness per gallon (GPG) (.75 grains of hardness per liter) must be treated and softened before being supplied to booster heater(s). Water containing over 3.0 GPG (.75 GPL) will decrease the efficiency and reduce the operating life of the unit.

Note: Product failure caused by liming or sediment buildup is not covered under warranty.



HATCO CORPORATION P.O. Box 340500 Milwaukee, WI 53234-0500 U.S.A.
 (800) 558-0607 • (414) 671-6350 • Fax (800) 543-7521 • Int'l. Fax (414) 671-3976
 www.hatcocorp.com • E-mail: equipsales@hatcocorp.com

Form No. C-1006(S)

Printed in U.S.A.

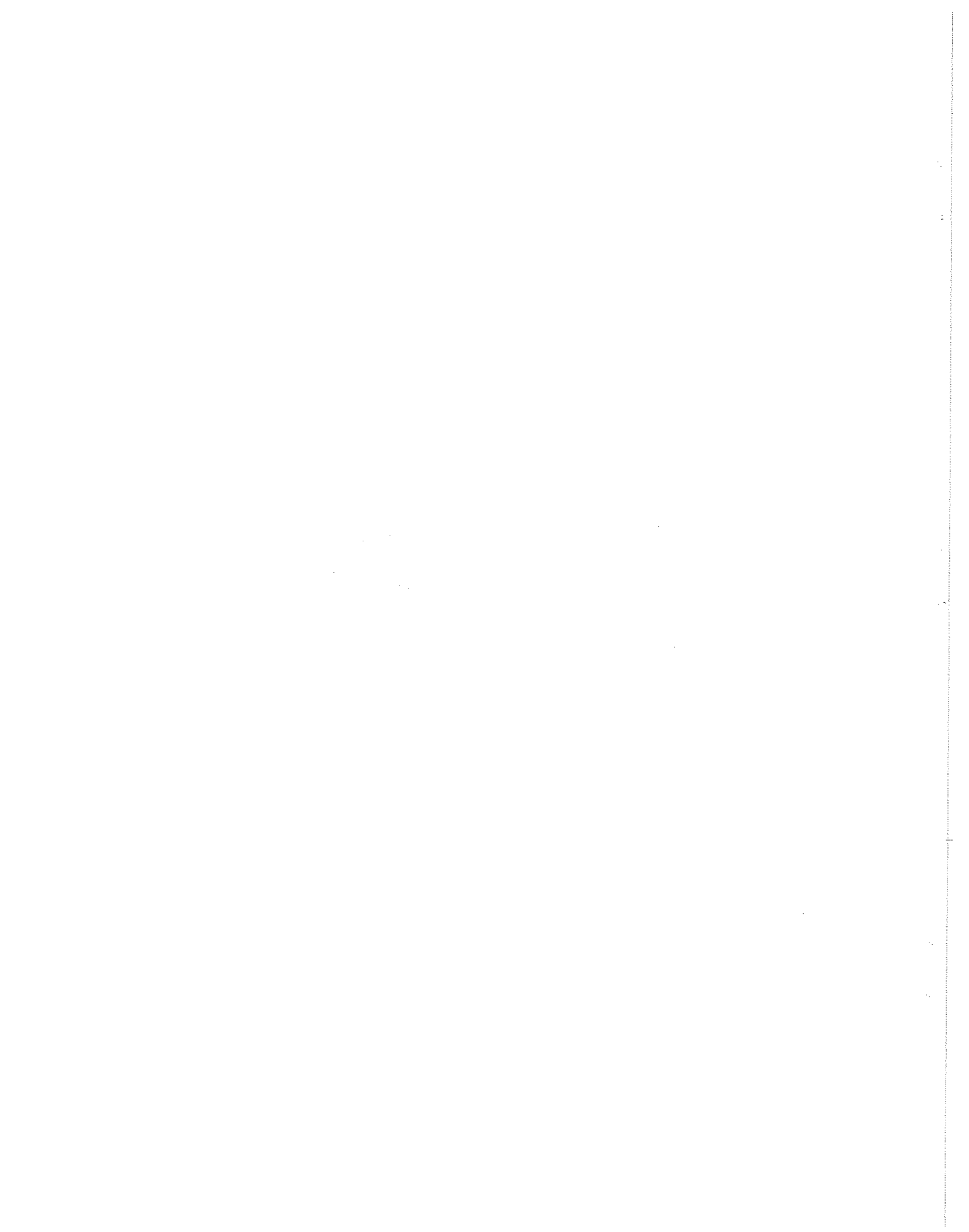

ITEM#



COMPACT ELECTRIC BOOSTER WATER HEATERS
 Models C-4, -5, -6, -7, -9, -12, -13, -15, -17, -18, -24, -27, -30, -36, -39, -45, -54, -57

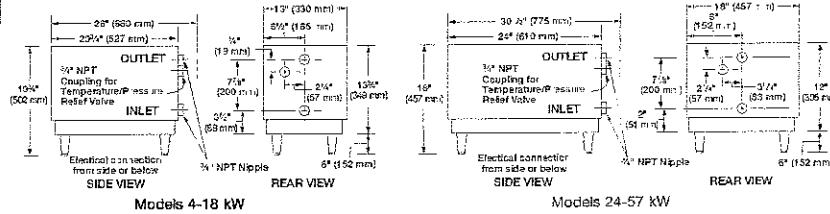

DIMENSIONS

4kW to 18kW: 13" W x 20 3/4" D (26" H) x 13 3/4" H without legs (330 x 527 (660 mm) x 349 mm).
 24kW to 57kW: 18" W x 24" D (30 1/2" H) x 12" H without legs (457 x 610 (775 mm) x 305 mm).
 † Includes Temperature/Pressure Relief Valve.

VOLTAGE

208, 240 and 480 volts available. Export voltages available.

SPECIFICATIONS

Model	kW	1-Phase			3-Phase		Shipping Weight
		Volts	Amps	Breaker/Fuse Size	Amps	Breaker/Fuse Size	
C-4	4	208	19	30	-	-	105 lbs. (48 kg)
		240	17	30	-	-	
		480	8	15	-	-	
C-5	5	208	24	30	-	-	105 lbs. (48 kg)
		240	21	30	-	-	
		480	10	15	-	-	
C-6*	6	208	29	40	25*	40	118 lbs. (54 kg)
		240	25	40	22*	30	
		480	-	-	11*	15	
C-7*	7	208	34	50	29*	40	118 lbs. (54 kg)
		240	29	40	25*	40	
		480	-	-	13*	20	
C-9*	9	208	43	60	38*	50	118 lbs. (54 kg)
		240	38	50	33*	50	
		480	-	-	16*	20	
C-12	12	208	58	90	33	50	120 lbs. (54 kg)
		240	50	70	29	40	
		480	-	-	14.5	20	
C-13	13.5	208	65	90	38	50	120 lbs. (54 kg)
		240	56.3	90	33	50	
		480	-	-	16.3	30	
C-15	15	208	72	90	41.7	60	120 lbs. (54 kg)
		240	62.5	90	36.1	50	
		480	-	-	18.1	30	
C-17†	17.2	208	-	-	47.9	60	120 lbs. (54 kg)
		240	-	-	-	-	
		480	-	-	-	-	
C-18§	18	208	86.5	125	-	-	120 lbs. (54 kg)
		240	75	100	43.4	60	
		480	-	-	21.7	30	

Model	kW	1-Phase			3-Phase		Shipping Weight
		Volts	Amps	Breaker/Fuse Size	Amps	Breaker/Fuse Size	
C-24	24	208	115.4	150	67.7	90	142 lbs. (64 kg)
		240	100	125	57.8	90	
		480	-	-	29.9	40	
C-27	27	208	129.8	175	75	100	142 lbs. (64 kg)
		240	112.5	150	65	90	
		480	-	-	32.5	50	
C-30	30	208	144	200	83.3	125	142 lbs. (64 kg)
		240	125	175	72.3	100	
		480	-	-	36	50	
C-36	36	208	173	225	100	125	142 lbs. (64 kg)
		240	150	200	86.7	125	
		480	-	-	43.3	60	
C-39	39	208	187.5	250	108	150	142 lbs. (64 kg)
		240	163.5	225	94	125	
		480	-	-	47	60	
C-45*	45	208	-	-	125	175	142 lbs. (64 kg)
		240	188	250	108	150	
		480	-	-	54	70	
C-54**	54	208	-	-	150	200	142 lbs. (64 kg)
		240	-	-	130	175	
		480	-	-	65	90	
C-57***	57	208	-	-	158.4	225	142 lbs. (64 kg)
		240	-	-	137.3	200	
		480	-	-	68.6	90	

* Only 6, 7, & 9kW Models. 208 and 240 volts only, can be field converted to single phase (units are shipped 3-phase open delta). Larger branch circuit required than for balanced 3-phase of equal kW (Balanced 3-phase available, consult factory).
 † 17.2kW models available in 208V 3-phase only.
 § 18kW models not available in 208V 3-phase.
 * Not available in 208V single phase.
 *** Not available in 208V or 240V single phase.

OPTIONS (NOT FOR RETROFIT)

- All Stainless Steel Body and Base
- Slide Brackets (In lieu of Standard 6" (152 mm) Legs)
- Adjustable Stainless Steel Legs 6" to 7" (152 to 178 mm)
- Brass Pressure Reducing Valve with Bypass

- Floor Mounting Hardware
- Security Package

ACCESSORIES

- Blended Phosphate Water Treatment System
- Shock Absorber - To Reduce Water Hammer

PRODUCT SPECS

Electric Booster Water Heater

The Electric Booster Water Heater to supply the final 180°F (82°C) rinse for the dishwasher shall be a Compact Model ... as manufactured for commercial use by the Hatco Corporation, Milwaukee, WI 53234 U.S.A.

The booster shall have the capacity to heat ...gph (lph) from 120°F to 180°F (49°C to 82°C) and it shall be rated at ...kW, ...volts, ...phase. The tank shall be designed for a working pressure of 150 psi (1034 kPa) and hydrostatically tested at 300 psi (2069 kPa) with a Hatco Castone® lining.

The heater shall be complete with all internal plumbing, including 3/4" NPT pipe and fittings for inlet and outlet. All controls shall be built-in, including contactors and prewired in accordance with

UL #1453 and 422.11 NEL 2002. Proper surface mounting circuit breaker or fused disconnect switch shall be provided by electrical contractor.

Electric heating elements shall be metal sheathed, controlled by an ambient compensating immersion thermostat. The booster shall be protected with high-temperature limit switch (ECO) and low-water cut-off.

The heater shall consist of stainless steel front and silver-gray hammertone body with standard 6" (152 mm) legs (or stainless steel body, base, and stainless steel adjustable legs).

The heater shall include a temperature/pressure relief valve, high-temperature pressure reducing valve with bypass, and two indicating temperature/pressure gauges.

HATCO CORPORATION P.O. Box 340500 Milwaukee, WI 53234-0500 U.S.A. • (800) 558-0607 • (414) 671-6350
Fax (800) 543-7521 • Int'l. Fax (414) 671-3976 • www.hatcocorp.com • E-mail: equipmentsales@hatcocorp.com

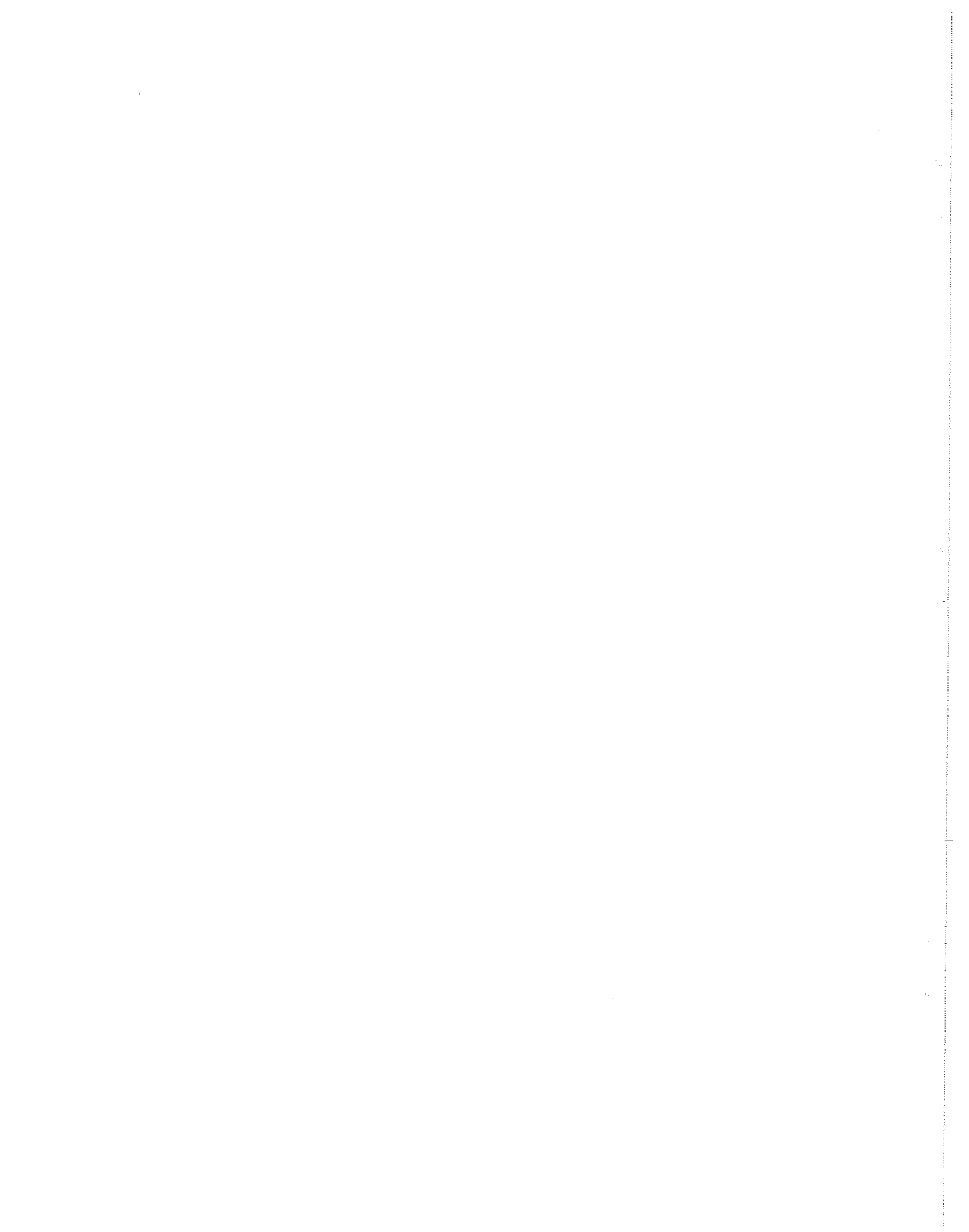

PROJECT: _____ ITEM NO.: _____



3 H.P. heavy duty disposer is designed for continuous operation in restaurants, hotels, hospitals and cafeterias. Food waste including steak bones is quickly and efficiently removed with this labor-saving, self-cleaning, environmentally sound disposer.

3 H.P. MODEL SS-300

SPECIFICATIONS

- GRIND CHAMBER -** Corrosion Resistant Stainless Steel
- MOUNTING -** 3/4" rubber mounting above grinding chamber isolates sound and eliminates vibration. Mounting is enclosed in chrome plated covers for sanitation and appearance
- MOTOR -** 3 HP Induction Motor, 1725 RPM's, totally enclosed to provide protection against outside moisture. Controlled power air flow cools motor for efficiency and longer life. Built-in thermal overload protection
- CUTTING ELEMENTS -** Stationary and rotating shredding elements made from cast nickel chrome alloy for long life and corrosion resistance. designed for reverse action grinding
- MAIN BEARINGS -** Double-tapered Timken roller bearings provide a shock absorbing cushion
- MOTOR SEALS -** Triple lip seal protects motor from water damage. Secondary spring-loaded oil seal provides double protection against water and loss of grease
- FINISH -** All Stainless Steel and Chrome plated. Paint-free for lasting sanitation
- WARRANTY -** 1 year full warranty from date of installation



BASE DISPOSER/ELECTRICAL REQUIREMENTS

- 208 volts 3 phase 3.3 amps
- 230 volts 3 phase 5.0 amps
- 460 volts 3 phase 2.5 amps

NOTE: All amp ratings denote the amp draw during a grind load.

DISPOSER MOUNTING ASSEMBLIES



#6 Collar Adapter for welding into trough, provides 6 5/8" opening, includes splash baffle



#7 Collar Adapter for welding into sink provides 6 5/8" opening, includes splash baffle and stopper



Type A Sink Bowl Assembly*



Type B Sink Bowl Assembly*



Type C Sink Bowl Assembly*

Select Sink Bowl Assembly Size

- 12" with one adjustable water nozzle
- 15" with one adjustable water nozzle
- 18" with two adjustable water nozzles

*If using Type A, B, or C you must specify either a 12", 15" or 18" sink bowl

ELECTRICAL CONTROLS



Manual Switch (Single Direction)

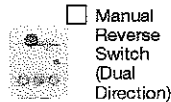

Manual Reverse Switch (Dual Direction)

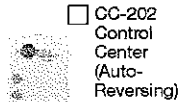

CC-202 Control Center (Auto-Reversing)

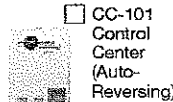

CC-101 Control Center (Auto-Reversing)

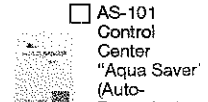

AS-101 Control Center "Aqua Saver" (Auto-Reversing)

WATER CONTROLS

- Solenoid Valve
- Syphon Breaker
- Flow Control Valve

Recommended Water Usage

Standard 8 GPM Optional 7 GPM

For additional information see Commercial Product Information Binder

A COMMERCIAL DISPOSER PACKAGE INCLUDES:

1 Mounting/Bowl Assembly, 1 Electrical Control, 1 Syphon Breaker, 1 Solenoid Valve, and 1 Flow Control Valve. The standard Flow Control Valve will be sent with the unit unless the optional valve is specified.

Our products appear on **The KCL CADalog** CD-ROM based CAD Foodservice Symbol Library. More information is available from **Kochman Consultants, Ltd.** at www.kclcad.com

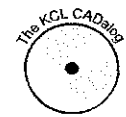

4700 21st STREET
RACINE, WI 53406
TEL: 800-845-8345
FAX: 262-554-3620

www.insinkerator.com



The Emerson logo is a trademark and a service mark of Emerson Electric Co.



InSinkErator is a division of Emerson Electric Co.

© InSinkErator Printed in USA Form No. F178-06E-19-02

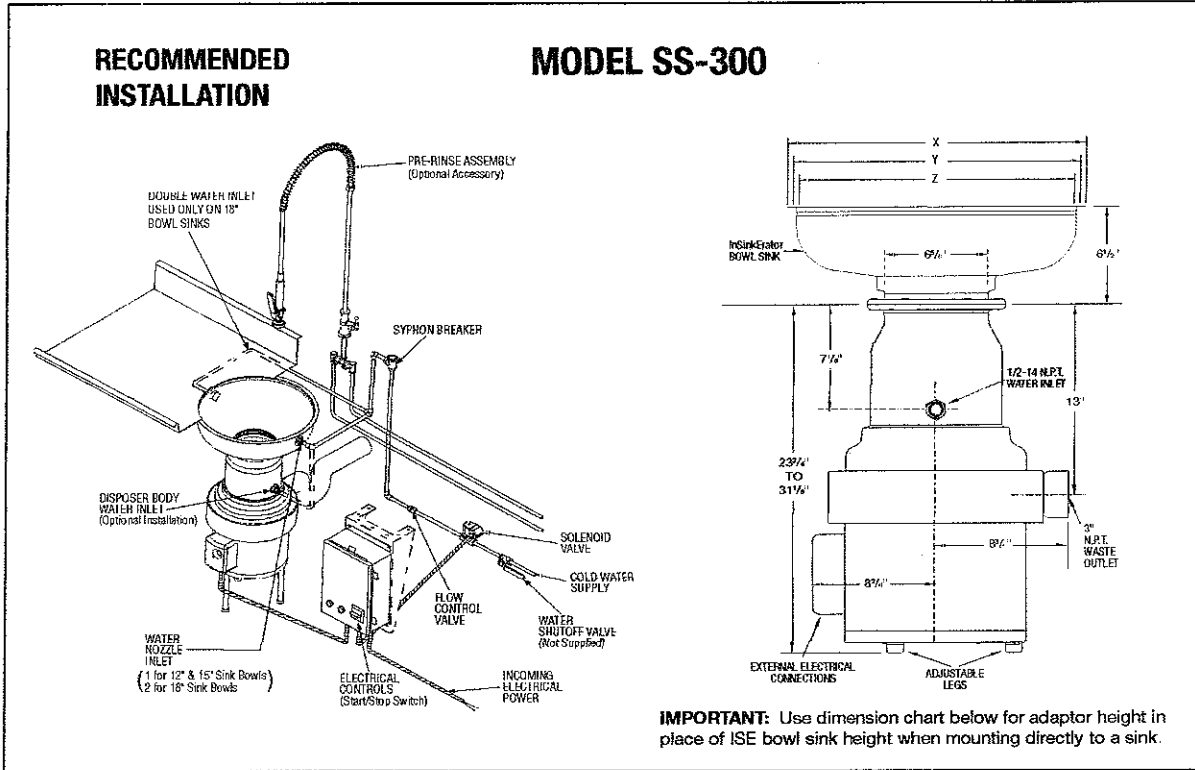

DIMENSIONS

X -- Flange O.D.
 Y -- Diameter of Work Table Hole
 Z -- Flange I.D.

BOWL SINKS	X	Y	Z	HEIGHT
12"	13 1/2"	12 1/4"	12"	6 1/2"
15"	16 1/2"	15 1/4"	15"	6 1/2"
18"	19 1/2"	18 1/4"	18"	6 1/2"
ADAPTORS	X	Y	Z	HEIGHT
No.6	7 13/16"	6 7/8"	6 5/8"	1 3/16"
No.7	9 1/8"	7 7/8"	7 5/8"	2 1/16"

3 H.P. COMMERCIAL DISPOSER

SAMPLE SPECIFICATION

ITEM NO. _____ DISPOSER
 Quantity: One required (1)
 Manufacturer: InSinkErator Division,
 Commercial Racine, WI
 Model: SS-300-15B/CC101
 Electrical Requirements: _____ volts/
 _____ phase
 Install in _____, Item _____

NOTE:

- Adaptors are available upon request for all competitor sink bowls or cones.
- Please have sink bowl/cone type with the necessary dimensions when ordering adaptors.
- Also available as short body model. Reduces overall height of disposer by 3 1/2".



T&S BRASS AND BRONZE WORKS, INC.
 2 SADDLEBACK COVE / P.O. BOX 1088 / TRAVELERS REST, SC 29690
 PHONE 800-476-4103 - FAX 864- 834-3518



Model No.
B-0133-01
RELIABILITY
BUILT IN

Job Name:

Architect/Engineer Approval:

Notes:

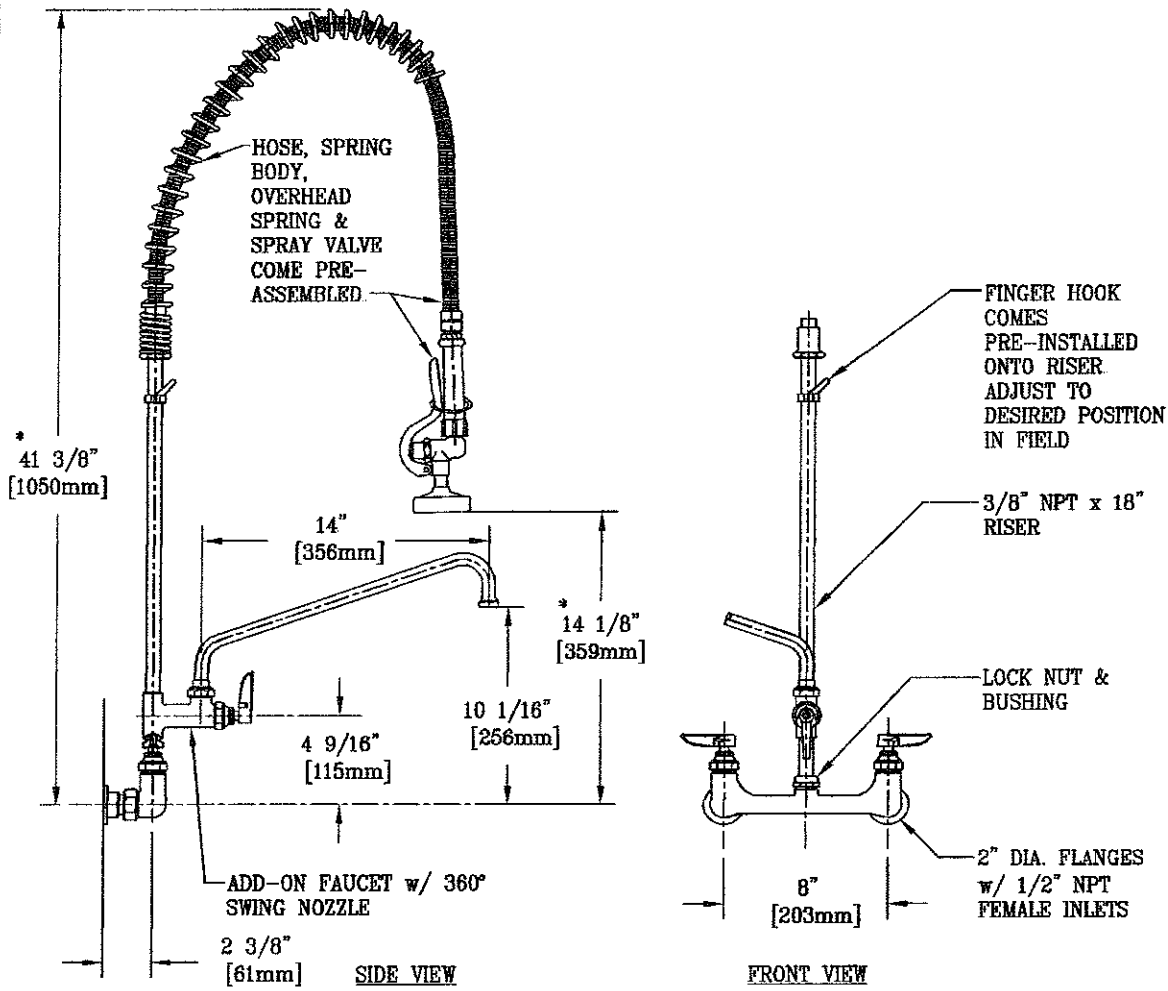

* DIMENSIONS MAY VARY ± 1/2" ON EACH INSTALLATION

Product Description:

EASY INSTALL PRE-RINSE UNIT:

8" c/c WALL MOUNT BASE FAUCET, 1/2" NPT FEMALE INLETS, 18" RISER, ADD ON FCT, 14" SWING NOZZLE, SUPPORT SPRING, 44" FLEX HOSE, B-0107 SPRAY

Drawn:

WJS

Checked

LEL

Scale:

1 : 8

Approved

MVW

Date:

6/19/03

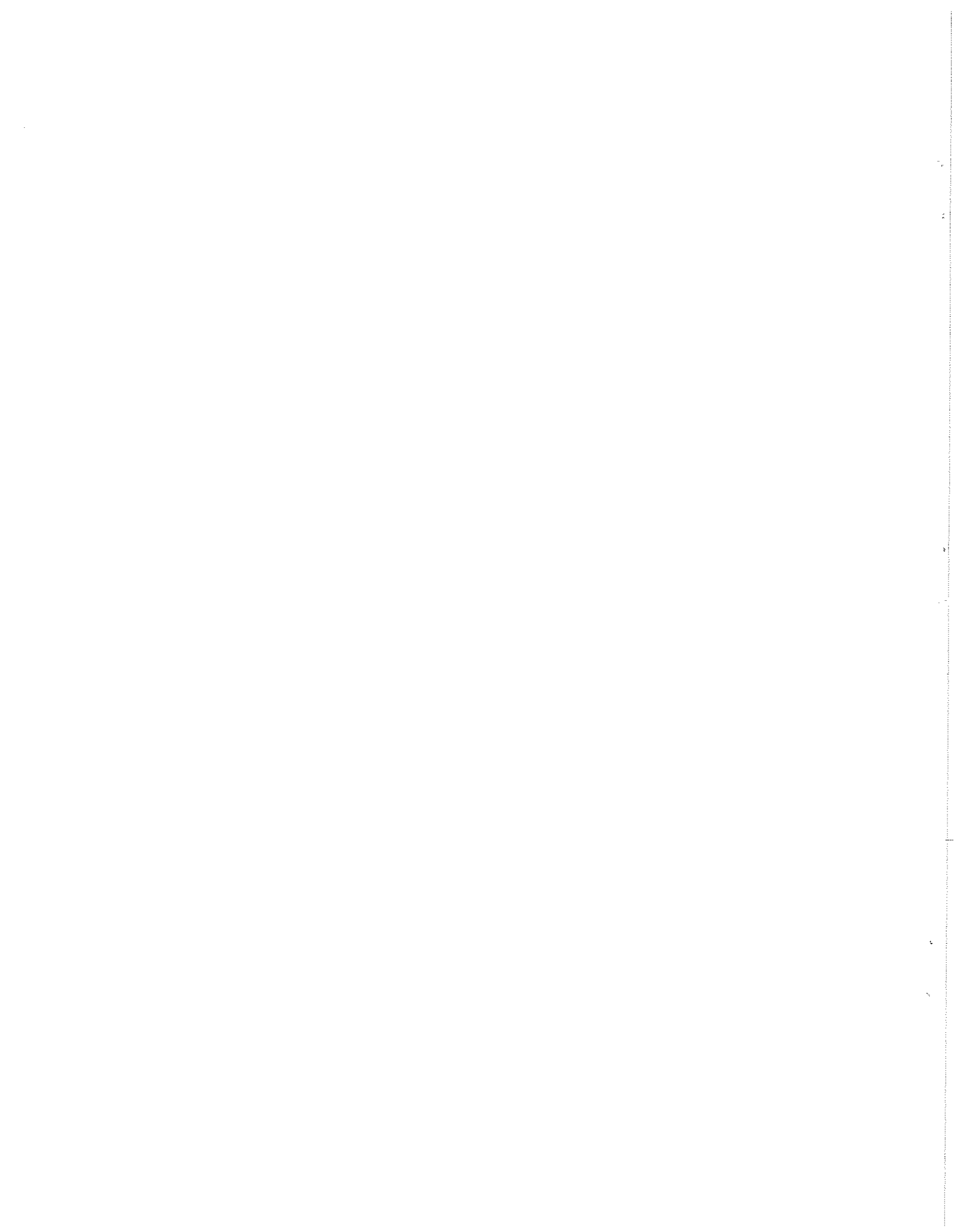



T&S BRASS AND BRONZE WORKS, INC.
 2 SADDLEBACK COVE / P.O. BOX 1088 / TRAVELERS REST, SC 29690
 PHONE 800-476-4103 FAX 864-834-3518



Model No.
B-0109-01
Item No.:

Job Name:	Architect/Engineer Approval:
-----------	------------------------------

Notes:

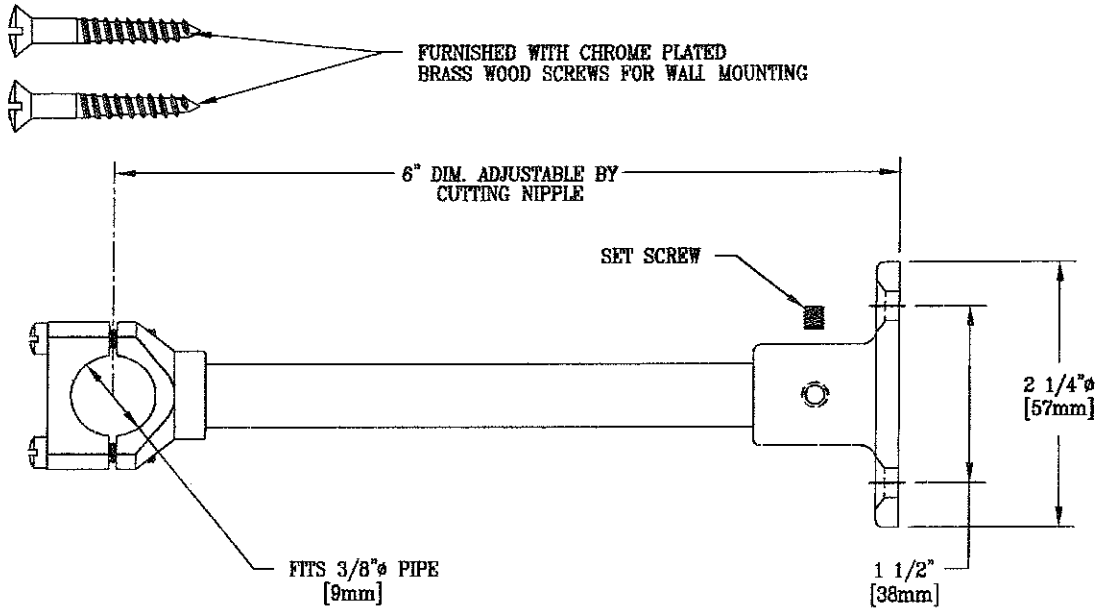

RECOMMENDED FOR USE WITH ALL UPRIGHT PRE-RINSE UNITS.

Product Description: 6" WALL BRACKET ASSEMBLY WITH MOUNTING HARDWARE	Drawn:	Checked	Scale:
	MCW	MW	9"=1'
	Approved:		Date:
	CA		10/12/95

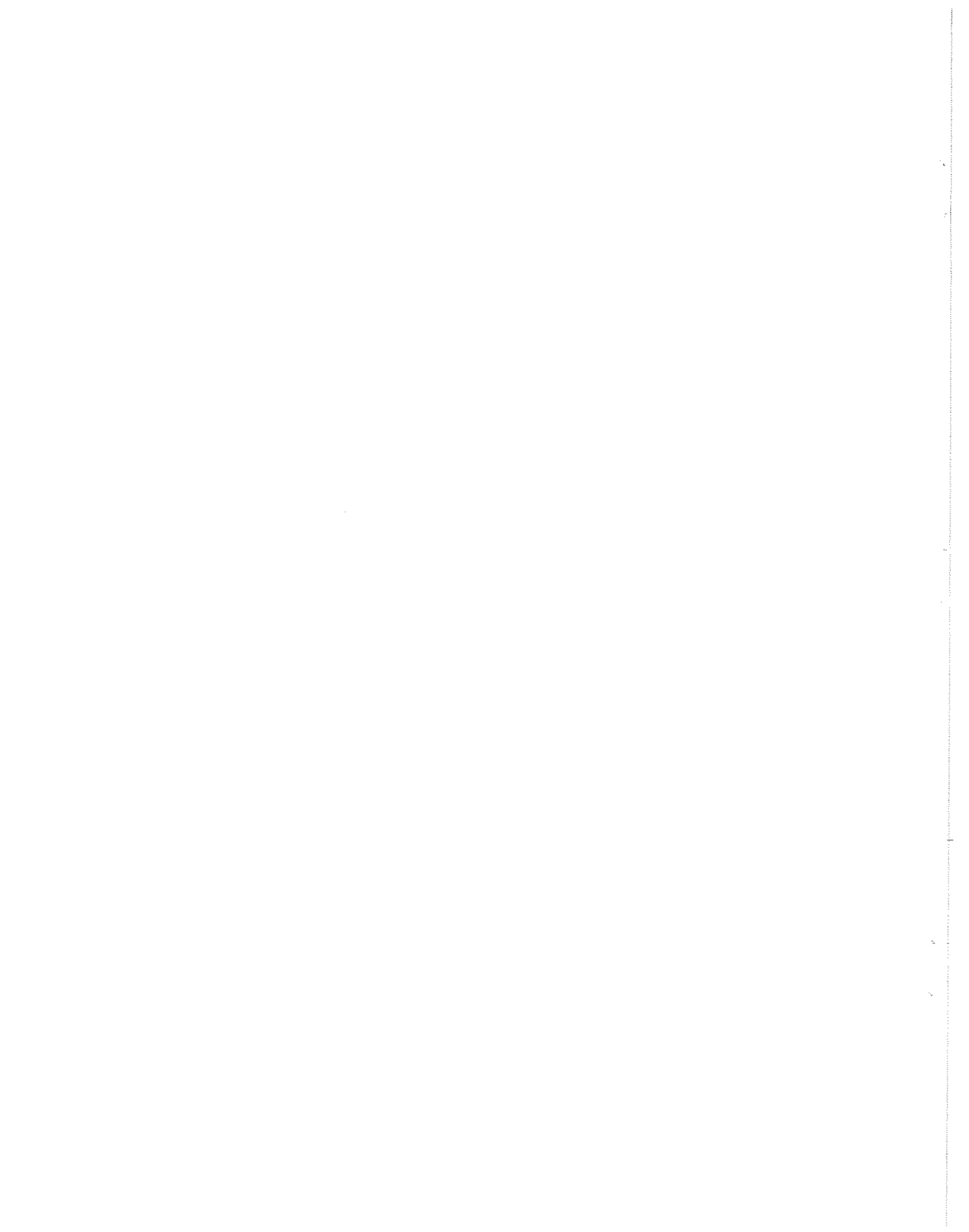



T&S BRASS AND BRONZE WORKS, INC.
 2 SADDLEBACK COVE / P.O. BOX 1088 / TRAVELERS REST, SC 29690
 PHONE 800-476-4103 FAX 864- 834-3518



Model No.
FLANGE-1
 Item No.:

Job Name: _____ Architect/Engineer Approval: _____

Notes: _____

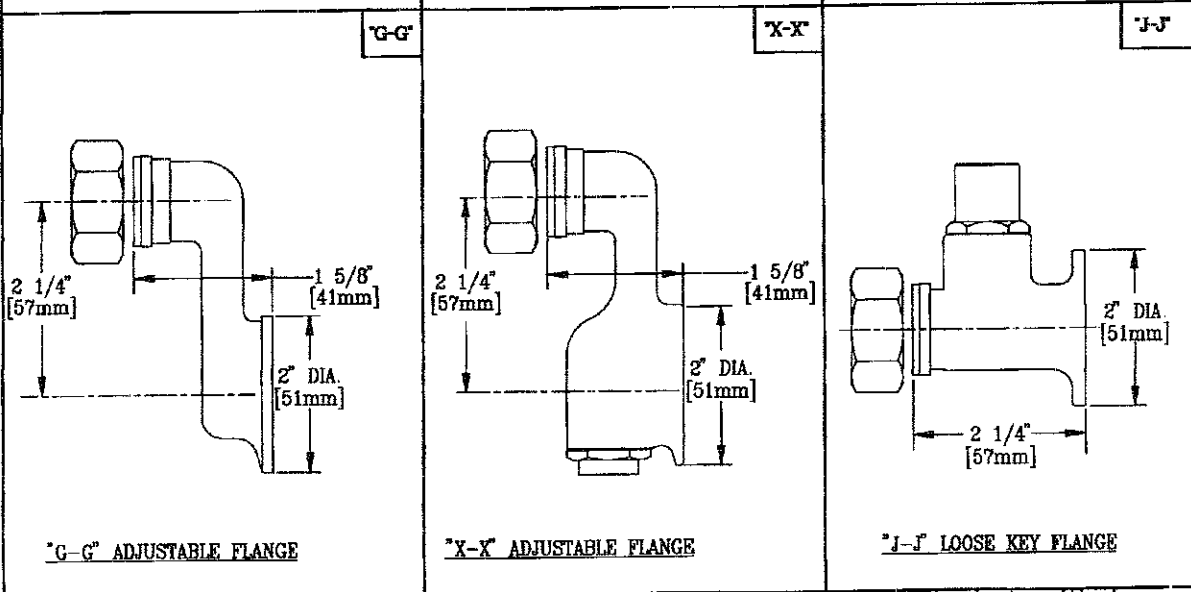
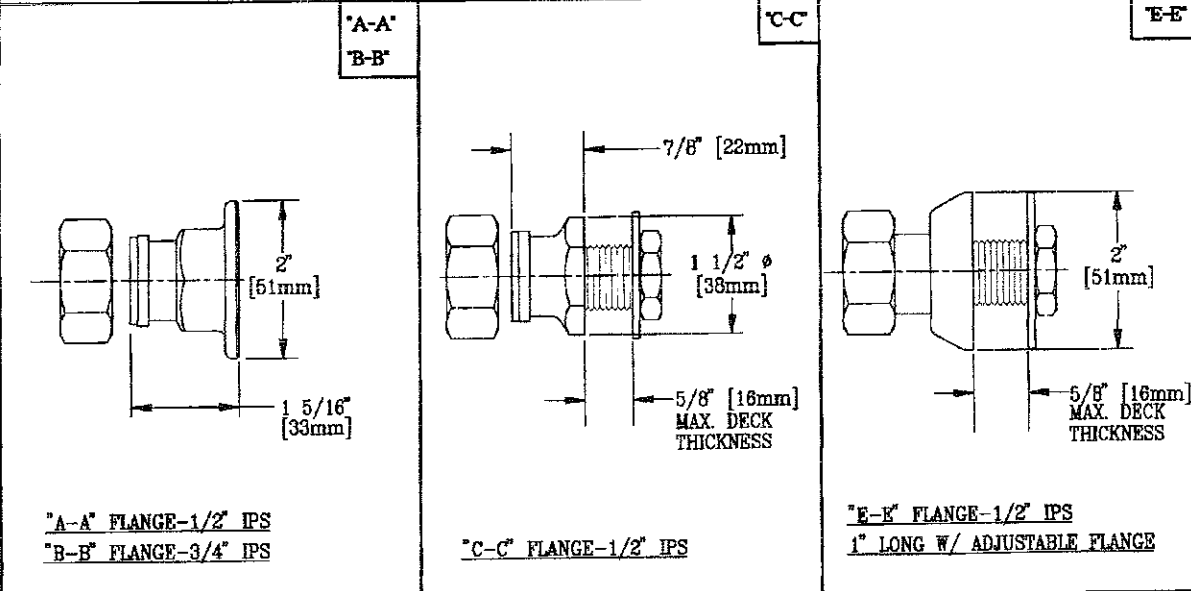

Product Description: T & S FLANGES : "A-A", "B-B", "C-C", "E-E", "G-G", "X-X", "J-J"	Drawn: WJS	Checked: MWR	Scale: 6" = 1'
	Approved: CA		Date: 2-15-96



T&S BRASS AND BRONZE WORKS, INC.
 2 SADDLEBACK COVE / P.O. BOX 1088 / TRAVELERS REST, SC 29690
 PHONE 800-476-4103 - FAX 864- 834-3518



Model No.
B-0113-B
RELIABILITY BUILT IN

Job Name:

Architect/Engineer Approval:

Notes:

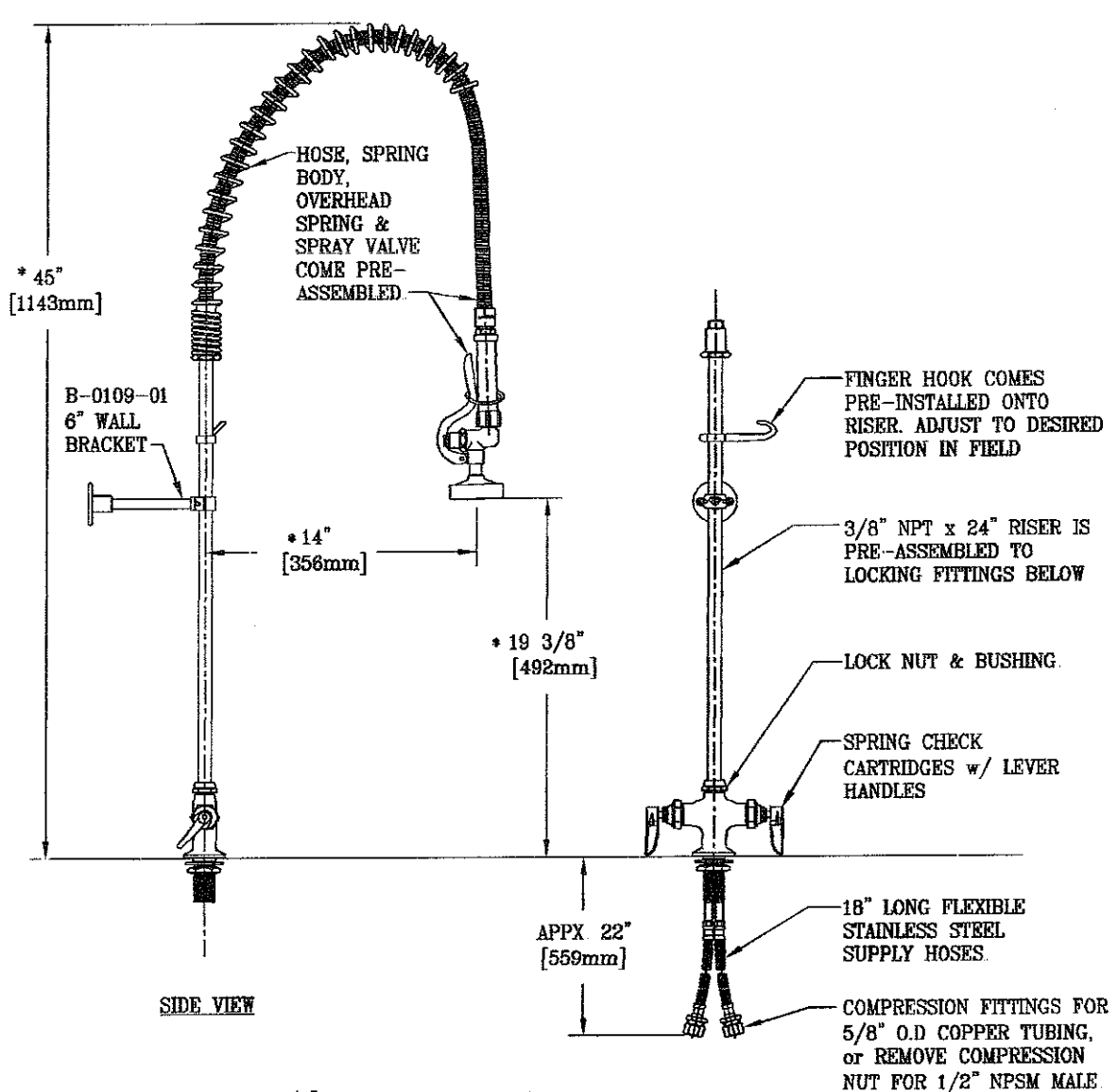

* DIMENSIONS MAY VARY ± 1/2" ON EACH INSTALLATION

FRONT VIEW

Product Description:
 EASY INSTALL PRE-RINSE UNIT:
 SINGLE DECK MOUNT BASE MIXING FAUCET, FLEXIBLE SUPPLY HOSES,
 24" RISER, SUPPORT SPRING, 44" FLEX HOSE, B-0107 SPRAY VALVE, 6" WALL BRACKET

Drawn:	Checked	Scale:
WJS	LEL	1 : 8
Approved	Date:	
MVW	6/19/03	

