



State of West Virginia  
 Department of Administration  
 Purchasing Division  
 2019 Washington Street East  
 Post Office Box 50130  
 Charleston, WV 25305-0130

# Request for Quotation

RFQ NUMBER
HST0741

PAGE
1

ADDRESS CORRESPONDENCE TO ATTENTION OF
RON PRICE 304-558-0492

VENDOR

\*117134613      304-204-2435  
 WV TRUCK & TRAILER CO INC  
 #1 JAIN DRIVE  
 CROSS LANES WV 25313

SHIP TO

HEALTH, SAFETY AND TRAINING  
 OFFICE OF MINERS'  
 1615 WASHINGTON STREET EAST  
 CHARLESTON, WV  
 25311

DATE PRINTED	TERMS OF SALE	SHIP VIA	F.O.B.	FREIGHT TERMS
02/11/2007				

BID OPENING DATE: 02/21/2007      BID OPENING TIME 01:30PM

LINE	QUANTITY	UOP	CAT NO.	ITEM NUMBER	UNIT PRICE	AMOUNT
				ADDENDUM NO. 1		
				CHANGE THE BID OPENING DATE FROM 2/14/07 TO 2/21/07		
				CHANGE THE SIZE OF THE STORAGE BOXES FROM 24 X 24 X 48 TO 24 X 24 X 60.		
0001	2	EA		070-51	\$ 88,529 <sup>00</sup>	\$ 177,058 <sup>00</sup>
				TRUCKS, GVW LESS THAN 26,000 LBS.		
				***** THIS IS THE END OF RFQ HST0741 ***** TOTAL:		\$ 177,058 <sup>00</sup>

SEE REVERSE SIDE FOR TERMS AND CONDITIONS

SIGNATURE	TELEPHONE	DATE
<i>Roger Meadows</i>	304-204-2435	2-21-07
TITLE	FEIN	ADDRESS CHANGES TO BE NOTED ABOVE
Asst General Manager	55-06773B	

WHEN RESPONDING TO RFQ, INSERT NAME AND ADDRESS IN SPACE ABOVE LABELED 'VENDOR'



State of West Virginia  
 Department of Administration  
 Purchasing Division  
 2019 Washington Street East  
 Post Office Box 50130  
 Charleston, WV 25305-0130

# Request for Quotation

RFQ NUMBER
HST0741

PAGE
1

ADDRESS CORRESPONDENCE TO ATTENTION OF
RON PRICE 304-558-0492

VENDOR

\*117134613 304-204-2435  
 WV TRUCK & TRAILER CO INC  
 #1 JAIN DRIVE  
 CROSS LANES WV 25313

SHIP TO

HEALTH, SAFETY AND TRAINING  
 OFFICE OF MINERS'  
 1615 WASHINGTON STREET EAST  
 CHARLESTON, WV  
 25311

DATE PRINTED	TERMS OF SALE	SHIP VIA	F.O.B.	FREIGHT TERMS
01/30/2007				

BID OPENING DATE: 02/14/2007 BID OPENING TIME 01:30PM

LINE	QUANTITY	UOP	CAT NO	ITEM NUMBER	UNIT PRICE	AMOUNT
0001	2	EA		070-51		
TRUCKS, GVW LESS THAN 26,000 LBS.  PER THE ATTACHED SPECIFICATIONS  THE MODEL/BRAND/SPECIFICATIONS NAMED HEREIN ESTABLISH THE ACCEPTABLE LEVEL OF QUALITY ONLY AND ARE NOT INTENDED TO REFLECT A PREFERENCE OR FAVOR ANY PARTICULAR BRAND OR VENDOR. VENDORS WHO ARE BIDDING ALTERNATES SHOULD SO STATE AND INCLUDE PERTINENT LITERATURE AND SPECIFICATIONS. FAILURE TO PROVIDE INFORMATION FOR ANY ALTERNATES MAY BE GROUNDS FOR REJECTION OF THE BID. THE STATE RESERVES THE RIGHT TO WAIVE MINOR IRREGULARITIES IN BIDS OR SPECIFICATION IN ACCORDANCE WITH SECTION 148-1-4(F) OF THE WEST VIRGINIA LEGISLATIVE RULES AND REGULATIONS.  VENDOR PREFERENCE CERTIFICATE  CERTIFICATION AND APPLICATION* IS HEREBY MADE FOR PREFERENCE IN ACCORDANCE WITH WEST VIRGINIA CODE, 5A-3-37 (DOES NOT APPLY TO CONSTRUCTION CONTRACTS).  A. APPLICATION IS MADE FOR 2.5% PREFERENCE FOR THE REASON CHECKED:  <input type="checkbox"/> BIDDER IS AN INDIVIDUAL RESIDENT VENDOR AND HAS RESIDED CONTINUOUSLY IN WEST VIRGINIA FOR FOUR (4) YEARS IMMEDIATELY PRECEDING THE DATE OF THIS CERTIFICATION; OR  <input checked="" type="checkbox"/> BIDDER IS A PARTNERSHIP, ASSOCIATION OR CORPORA-						

SEE REVERSE SIDE FOR TERMS AND CONDITIONS

SIGNATURE	TELEPHONE	DATE
TITLE	FEIN	ADDRESS CHANGES TO BE NOTED ABOVE

WHEN RESPONDING TO RFQ, INSERT NAME AND ADDRESS IN SPACE ABOVE LABELED 'VENDOR'



State of West Virginia  
 Department of Administration  
 Purchasing Division  
 2019 Washington Street East  
 Post Office Box 50130  
 Charleston, WV 25305-0130

# Request for Quotation

RFQ NUMBER
HST0741

PAGE
2

ADDRESS CORRESPONDENCE TO ATTENTION OF:
RON PRICE 304-558-0492

VENDOR

\*117134613      304-204-2435  
 WV TRUCK & TRAILER CO INC  
 #1 JAIN DRIVE  
 CROSS LANES WV 25313

SHIP TO

HEALTH, SAFETY AND TRAINING  
 OFFICE OF MINERS'  
 1615 WASHINGTON STREET EAST  
 CHARLESTON, WV  
 25311

DATE PRINTED	TERMS OF SALE	SHIP VIA	F.O.B.	FREIGHT TERMS
01/30/2007				

BID OPENING DATE: 02/14/2007      BID OPENING TIME 01:30PM

LINE	QUANTITY	UOP	CAT NO	ITEM NUMBER	UNIT PRICE	AMOUNT
<p>TION RESIDENT VENDOR AND HAS MAINTAINED ITS HEAD-            QUARTERS OR PRINCIPAL PLACE OF BUSINESS CONTINUOUSLY IN            WEST VIRGINIA FOR FOUR (4) YEARS IMMEDIATELY PRECEDING            THE DATE OF THIS CERTIFICATION; OR 80% OF THE OWNERSHIP            INTEREST OF BIDDER IS HELD BY ANOTHER INDIVIDUAL,            PARTNERSHIP, ASSOCIATION OR CORPORATION RESIDENT VENDO            WHO HAS MAINTAINED ITS HEADQUARTERS OR PRINCIPAL PLACE            OF BUSINESS CONTINUOUSLY IN WEST VIRGINIA FOR FOUR (4)            YEARS IMMEDIATELY PRECEDING THE DATE OF THIS            CERTIFICATION; OR</p> <p>( ) BIDDER IS A CORPORATION NONRESIDENT VENDOR            WHICH HAS AN AFFILIATE OR SUBSIDIARY WHICH EMPLOYS            A MINIMUM OF ONE HUNDRED STATE RESIDENTS AND WHICH            HAS MAINTAINED ITS HEADQUARTERS OR PRINCIPAL PLACE OF            BUSINESS WITHIN WEST VIRGINIA CONTINUOUSLY FOR THE            FOUR (4) YEARS IMMEDIATELY PRECEDING THE DATE OF THIS            CERTIFICATION.</p> <p>B. APPLICATION IS MADE FOR 2.5% PREFERENCE FOR THE            REASON CHECKED:</p> <p>(X) BIDDER IS A RESIDENT VENDOR WHO CERTIFIES THAT,            DURING THE LIFE OF THE CONTRACT, ON AVERAGE AT LEAST            75% OF THE EMPLOYEES WORKING ON THE PROJECT BEING BID            ARE RESIDENTS OF WEST VIRGINIA WHO HAVE RESIDED IN            THE STATE CONTINUOUSLY FOR THE TWO YEARS IMMEDIATELY            PRECEDING SUBMISSION OF THIS BID;            OR</p> <p>( ) BIDDER IS A NONRESIDENT VENDOR EMPLOYING A            MINIMUM OF ONE HUNDRED STATE RESIDENTS OR IS A            NONRESIDENT VENDOR WITH AN AFFILIATE OR SUBSIDIARY            WHICH MAINTAINS ITS HEADQUARTERS OR PRINCIPAL PLACE            OF BUSINESS WITHIN WEST VIRGINIA EMPLOYING A MINIMUM            OF ONE HUNDRED STATE RESIDENTS WHO CERTIFIES THAT,            DURING THE LIFE OF THE CONTRACT, ON AVERAGE AT LEAST</p>						

SEE REVERSE SIDE FOR TERMS AND CONDITIONS

SIGNATURE	TELEPHONE	DATE
TITLE	FEIN	ADDRESS CHANGES TO BE NOTED ABOVE

WHEN RESPONDING TO RFQ, INSERT NAME AND ADDRESS IN SPACE ABOVE LABELED 'VENDOR'



State of West Virginia  
 Department of Administration  
 Purchasing Division  
 2019 Washington Street East  
 Post Office Box 50130  
 Charleston, WV 25305-0130

# Request for Quotation

RFQ NUMBER
HST0741

PAGE
3

ADDRESS CORRESPONDENCE TO ATTENTION OF
RON PRICE 304-558-0492

VENDOR

\*117134613      304-204-2435  
 WV TRUCK & TRAILER CO INC  
 #1 JAIN DRIVE  
  
 CROSS LANES WV 25313

SHIP TO

HEALTH, SAFETY AND TRAINING  
 OFFICE OF MINERS'  
 1615 WASHINGTON STREET EAST  
  
 CHARLESTON, WV  
 25311

DATE PRINTED	TERMS OF SALE	SHIP VIA	F.O.B.	FREIGHT TERMS
01/30/2007				

BID OPENING DATE: 02/14/2007      BID OPENING TIME 01:30PM

LINE	QUANTITY	UOP	CAT NO.	ITEM NUMBER	UNIT PRICE	AMOUNT
<p>75% OF THE EMPLOYEES OR BIDDERS' AFFILIATE'S OR SUBSIDIARY'S EMPLOYEES ARE RESIDENTS OF WEST VIRGINIA WHO HAVE RESIDED IN THE STATE CONTINUOUSLY FOR THE TWO YEARS IMMEDIATELY PRECEDING SUBMISSION OF THIS BID.</p> <p>BIDDER UNDERSTANDS IF THE SECRETARY OF TAX &amp; REVENUE DETERMINES THAT A BIDDER RECEIVING PREFERENCE HAS FAILED TO CONTINUE TO MEET THE REQUIREMENTS FOR SUCH PREFERENCE, THE SECRETARY MAY ORDER THE DIRECTOR OF PURCHASING TO: (A) RESCIND THE CONTRACT OR PURCHASE ORDER ISSUED; OR (B) ASSESS A PENALTY AGAINST SUCH BIDDER IN AN AMOUNT NOT TO EXCEED 5% OF THE BID AMOUNT AND THAT SUCH PENALTY WILL BE PAID TO THE CONTRACTING AGENCY OR DEDUCTED FROM ANY UNPAID BALANCE ON THE CONTRACT OR PURCHASE ORDER.</p> <p>BY SUBMISSION OF THIS CERTIFICATE, BIDDER AGREES TO DISCLOSE ANY REASONABLY REQUESTED INFORMATION TO THE PURCHASING DIVISION AND AUTHORIZES THE DEPARTMENT OF TAX AND REVENUE TO DISCLOSE TO THE DIRECTOR OF PURCHASING APPROPRIATE INFORMATION VERIFYING THAT BIDDER HAS PAID THE REQUIRED BUSINESS TAXES, PROVIDED THAT SUCH INFORMATION DOES NOT CONTAIN THE AMOUNTS OF TAXES PAID NOR ANY OTHER INFORMATION DEEMED BY THE TAX COMMISSIONER TO BE CONFIDENTIAL.</p> <p>UNDER PENALTY OF LAW FOR FALSE SWEARING (WEST VIRGINIA CODE 61-5-3), BIDDER HEREBY CERTIFIES THAT THIS CERTIFICATE IS TRUE AND ACCURATE IN ALL RESPECTS; AND THAT IF A CONTRACT IS ISSUED TO BIDDER AND IF ANYTHING CONTAINED WITHIN THIS CERTIFICATE CHANGES DURING THE TERM OF THE CONTRACT, BIDDER WILL NOTIFY THE PURCHASING DIVISION IN WRITING IMMEDIATELY.</p> <p>BIDDER: <i>[Signature]</i> WU Truck</p>						

SEE REVERSE SIDE FOR TERMS AND CONDITIONS

SIGNATURE	TELEPHONE	DATE
TITLE	FEIN	ADDRESS CHANGES TO BE NOTED ABOVE

WHEN RESPONDING TO RFQ, INSERT NAME AND ADDRESS IN SPACE ABOVE LABELED 'VENDOR'



State of West Virginia  
 Department of Administration  
 Purchasing Division  
 2019 Washington Street East  
 Post Office Box 50130  
 Charleston, WV 25305-0130

# Request for Quotation

RFQ NUMBER
HST0741

PAGE
4

ADDRESS CORRESPONDENCE TO ATTENTION OF:
RON PRICE 304-558-0492

VENDOR

\*117134613      304-204-2435  
 WV TRUCK & TRAILER CO INC  
 #1 JAIN DRIVE  
 CROSS LANES WV 25313

SHIP TO

HEALTH, SAFETY AND TRAINING  
 OFFICE OF MINERS'  
 1615 WASHINGTON STREET EAST  
 CHARLESTON, WV  
 25311

DATE PRINTED	TERMS OF SALE	SHIP VIA	F.O.B.	FREIGHT TERMS
01/30/2007				

BID OPENING DATE: 02/14/2007      BID OPENING TIME 01:30PM

LINE	QUANTITY	UOP	CAT NO.	ITEM NUMBER	UNIT PRICE	AMOUNT
DATE: <u>2-20-2007</u> SIGNED: <u>[Signature]</u> TITLE: <u>General Manager</u>						
* CHECK ANY COMBINATION OF PREFERENCE CONSIDERATION(S) IN EITHER "A" OR "B", OR BOTH "A" AND "B" WHICH YOU ARE ENTITLED TO RECEIVE. YOU MAY REQUEST UP TO THE MAXIMUM 5% PREFERENCE FOR BOTH "A" AND "B". (REV. 12/00)						
NOTICE						
A SIGNED BID MUST BE SUBMITTED TO:  DEPARTMENT OF ADMINISTRATION PURCHASING DIVISION BUILDING 15 2019 WASHINGTON STREET, EAST CHARLESTON, WV 25305-0130						
THE BID SHOULD CONTAIN THIS INFORMATION ON THE FACE OF THE ENVELOPE OR THE BID MAY NOT BE CONSIDERED:  SEALED BID						
BUYER: 41						

SEE REVERSE SIDE FOR TERMS AND CONDITIONS

SIGNATURE	TELEPHONE	DATE
-----------	-----------	------

TITLE	FEIN	ADDRESS CHANGES TO BE NOTED ABOVE
-------	------	-----------------------------------

WHEN RESPONDING TO RFQ, INSERT NAME AND ADDRESS IN SPACE ABOVE LABELED 'VENDOR'

## SPECIFICATIONS

### TRUCK AND BODY TO SERVE AS A MOBILE MINE RESCUE STATION.

Desired truck is a 7500 GMC, Freightliner MD 80, International 4300 series or equivalent, with a 24-foot box body with a three-foot over the cab extension.

Bids must apply to purchase of more than one truck. (One or two trucks may be purchased at this time )

The truck must have:

A GVW of less than 26000 lbs.

A height to the top of the frame rails of not more than 36 inches.

Tire size 245/75 R22.5, mud and snow on rear, straight tread on front

Dual saddle fuel tanks of at least 45 gallons each

A diesel engine rated at a minimum of 275-horse power with at least 700 lbs of torque.

An automatic transmission with dash mounted selector switch.

Air brakes with dash mounted park brake.

Dual bucket seats in cab.

Heater, defroster, air conditioner, rubber floor mat and FM radio in cab.

Mirrors to be single post design with flat and convex mirrors in same frame.

All standard gauges, controls, switches and indicators as usually found in such vehicles.

Vehicle must meet all accepted standards for the motor truck industry for frame size and length to accept and properly mount the 24-foot box body.

Vehicle must meet all state and federal laws and requirements for lighting, signaling and air brakes and meet all inspection requirements.

Body to be 24 feet long from back of cab to rear end, and have a 3-foot extension over the cab.

Body to be steel or aluminum skin attached to steel framing members with plastic or fiberglass reinforced plywood lining on the inside of the body.

Floor to be one and one half inch thick wood planks bolted to a steel frame.

Roof to be one piece stainless steel or aluminum with steel cross members.

Roof to be reinforced to support a center mounted heater/air conditioner and to have 12-inch square opening and wiring for same.

Body floor, walls and roof to be insulated to the fullest extent possible with Styrofoam or equivalent insulation. Bidder must state type and thickness of insulation for floor, walls and roof.

Body to have one sliding, 36 inch man door with a recessed step well to the floor of the body. This door to be on the passenger or curb side of the body 48 inches from the front of the body. Second door to be in the rear center of the body, 36 inches wide. Both doors to be lockable and keyed the same, and must be operable from inside or outside of the body.

Interior height of the body to be seven feet.

Body will be mounted as close to frame (as low) as practical

Body will have 4 aluminum underbody storage boxes installed in dual 3-inch channel iron mounts welded to the body frame. Three boxes will be 24X24X48 and will have dual swing out doors latched in the center. The right front box to be 24X24X24. Boxes to be "Highway Products" brand or equal. All four boxes to be lockable and keyed alike.

Body to have a steel frame welded to the underside to support a 7500-watt diesel generator. Frame to be enclosed to cover generator but still allow access for maintenance. Bidder will furnish and install a 7500 watt diesel generator (Onan "quiet diesel" or equal). Generator to use fuel from truck fuel system and start from the truck battery system.

Rear of body to have steel diamond plate step bumper and frame for steps to rear door. Bidder will supply a set of steps, with hand rail, to allow access to the rear door. These steps will fold or slide into the frame for transport while the truck is in motion. DOT bar to be part of rear frame or bumper.

Bidders must clearly state items in the bid requirements they are not in compliance with or wish to take exception to. Bidders must state delivery dates. Bidders should state any options they offer or think would better serve the purpose of this vehicle.

# AFFIDAVIT

**West Virginia Code §5A-3-10a states:**

No contract or renewal of any contract may be awarded by the state or any of its political subdivisions to any vendor or prospective vendor when the vendor or prospective vendor or a related party to the vendor or prospective vendor is a debtor and the debt owned is an amount greater than one thousand dollars in the aggregate

**DEFINITIONS:**

"Debt" means any assessment, premium, penalty, fine, tax or other amount of money owed to the state or any of its political subdivisions because of a judgment, fine, permit violation, license assessment, defaulted workers' compensation premium, penalty or other assessment presently delinquent or due and required to be paid to the state or any of its political subdivisions, including any interest or additional penalties accrued thereon

"Debtor" means any individual, corporation, partnership, association, limited liability company or any other form or business association owing a debt to the state or any of its political subdivisions. "Political subdivision" means any county commission; municipality; county board of education; any instrumentality established by a county or municipality; any separate corporation or instrumentality established by one or more counties or municipalities, as permitted by law; or any public body charged by law with the performance of a government function or whose jurisdiction is coextensive with one or more counties or municipalities. "Related party" means a party, whether an individual, corporation, partnership, association, limited liability company or any other form or business association or other entity whatsoever, related to any vendor by blood, marriage, ownership or contract through which the party has a relationship of ownership or other interest with the vendor so that the party will actually or by effect receive or control a portion of the benefit, profit or other consideration from performance of a vendor contract with the party receiving an amount that meets or exceed five percent of the total contract amount.

**EXCEPTION:**

The prohibition of this section does not apply where a vendor has contested any tax administered pursuant to chapter eleven of this code, workers' compensation premium, permit fee or environmental fee or assessment and the matter has not become final or where the vendor has entered into a payment plan or agreement and the vendor is not in default of any of the provisions of such plan or agreement

**LICENSING:**

Vendors must be licensed and in good standing in accordance with any and all state and local laws and requirements by any state or local agency of West Virginia, including, but not limited to, the West Virginia Secretary of State's Office, the West Virginia Tax Department, West Virginia Insurance Commission, or any other state agencies or political subdivision. Furthermore, the vendor must provide all necessary releases to obtain information to enable the Director or spending unit to verify that the vendor is licensed and in good standing with the above entities.

**CONFIDENTIALITY:**

The vendor agrees that he or she will not disclose to anyone, directly or indirectly, any such personally identifiable information or other confidential information gained from the agency, unless the individual who is the subject of the information consents to the disclosure in writing or the disclosure is made pursuant to the agency's policies, procedures and rules. Vendors should visit [www.state.wv.us/admin/purchase/privacy](http://www.state.wv.us/admin/purchase/privacy) for the Notice of Agency Confidentiality Policies

Under penalty of law for false swearing (West Virginia Code, §61-5-3), it is hereby certified that the vendor acknowledges the information in this said affidavit and are in compliance with the requirements as stated

Vendor's Name: West Virginia Truck + Trailer Co.

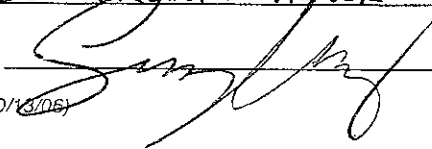
Authorized Signature:  Date: 2-20-2007





State of West Virginia  
 Department of Administration  
 Purchasing Division  
 2019 Washington Street East  
 Post Office Box 50130  
 Charleston, WV 25305-0130

# Request for Quotation

RFQ NUMBER
HST0741

PAGE
5

ADDRESS CORRESPONDENCE TO ATTENTION OF:
RON PRICE 304-558-0492

VENDOR

\*117134613      304-204-2435  
 WV TRUCK & TRAILER CO INC  
 #1 JAIN DRIVE  
 CROSS LANES WV 25313

SHIP TO

HEALTH, SAFETY AND TRAINING  
 OFFICE OF MINERS'  
 1615 WASHINGTON STREET EAST  
 CHARLESTON, WV  
 25311

DATE PRINTED	TERMS OF SALE	SHIP VIA	F.O.B.	FREIGHT TERMS
01/30/2007				

BID OPENING DATE: **02/14/2007**      BID OPENING TIME: **01:30PM**

LINE	QUANTITY	UOP	CAT NO	ITEM NUMBER	UNIT PRICE	AMOUNT
<p>RFQ. NO.: HST0741</p> <p>BID OPENING DATE: 2/14/07</p> <p>BID OPENING TIME: 1:30 PM</p> <p>PLEASE PROVIDE A FAX NUMBER IN CASE IT IS NECESSARY TO CONTACT YOU REGARDING YOUR BID:            -----  <i>304 204 2448</i></p> <p>CONTACT PERSON (PLEASE PRINT CLEARLY):  <i>DAVID MEEKS</i></p> <p>***** THIS IS THE END OF RFQ      HST0741 ***** TOTAL: <u><i>177,058<sup>00</sup></i></u></p>						

SEE REVERSE SIDE FOR TERMS AND CONDITIONS

SIGNATURE	TELEPHONE	DATE
TITLE	FEIN	ADDRESS CHANGES TO BE NOTED ABOVE

WHEN RESPONDING TO RFQ, INSERT NAME AND ADDRESS IN SPACE ABOVE LABELED 'VENDOR'



---

#1 Jain Drive, Cross Lanes, West Virginia 25313 • Phone (304) 204-2435 • Fax (304) 204-2447

February 20 2007

STATE OF WEST VIRGINIA DEPT. OF  
ADMINISTRATION PURCHASING DIVISION  
ATT. RON PRICE

Please find enclosed the bid RFQ NUMBER HST0741 for Health and Safety  
Training Truck. Price \$ 88,529.00 each includes cab chassis and body.  
If I may be of further assistance in this matter please feel free to contact me at  
304 204 2435

THANK YOU

A handwritten signature in cursive script that reads "Dave Meeks".

DAVE MEEKS  
WEST VIRGINIA TRUCK & TRAILER CO.  
FREIGHTLINER



*The Company that does things right.*

**Prepared for:**  
RON PRICE  
HEALTH AND SAFETY STATE OF  
WEST VIRGINIA  
1615 WASHINGTON ST EAST  
CHARLESTON, WV 25311  
Phone: 304 558 0492

**Prepared by:**  
Dave Meeks  
WEST VIRGINIA TRUCK & TRAILER  
COMPANY  
1 Jain Dr.  
Cross Lanes, WV 25313  
Phone: 304-204-2435

*A proposal for*  
**HEALTH AND SAFETY STATE OF WEST VIRGINIA**

*Prepared by*  
**WEST VIRGINIA TRUCK & TRAILER COMPANY**  
*Dave Meeks*

*February 20, 2007*

**M2 106 CONVENTIONAL CHASSIS**

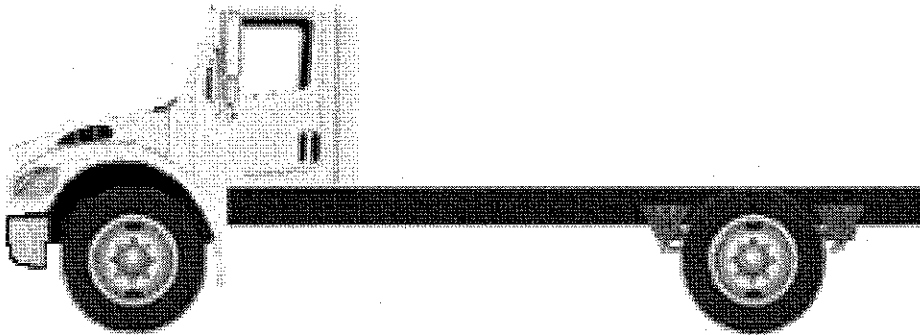

Prepared for:  
 RON PRICE  
 HEALTH AND SAFETY STATE OF  
 WEST VIRGINIA  
 1615 WASHINGTON ST EAST  
 CHARLESTON, WV 25311  
 Phone: 304 558 0492

Prepared by:  
 Dave Meeks  
 WEST VIRGINIA TRUCK & TRAILER  
 COMPANY  
 1 Jain Dr.  
 Cross Lanes, WV 25313  
 Phone: 304-204-2435

## S P E C I F I C A T I O N   P R O P O S A L

Data Code	Description	Weight Front	Weight Rear	Retail Price
<b>Price Level</b>				
PRL-72A	M2 PRL-72A (EFF:8/15/06)			N/C
<b>Data Version</b>				
DRL-010	SPECPRO21 DATA RELEASE VER 010			N/C
<b>Vehicle Configuration</b>				
001-172	M2 106 CONVENTIONAL CHASSIS	5,140	2,970	\$68 851 00
004-208	2008 MODEL YEAR SPECIFIED			N/C
002-004	SET BACK AXLE - TRUCK			STD
019-002	STRAIGHT TRUCK PROVISION			STD
003-001	LH PRIMARY STEERING LOCATION			STD
<b>General Service</b>				
AA1-002	TRUCK CONFIGURATION			STD
AA6-002	DOMICILED, USA 49 STATES (WITHOUT CALIFORNIA)			N/C
A85-002	PICKUP AND DELIVERY/SHORT HAUL SERVICE			STD
A84-1GF	GENERAL FREIGHT BUSINESS SEGMENT			STD
AA4-011	FIXED LOAD COMMODITY			N/C
AA5-002	TERRAIN/DUTY: 100% (ALL) OF THE TIME, IN TRANSIT, IS SPENT ON PAVED ROADS			STD
AB1-008	MAXIMUM 8% EXPECTED GRADE			STD
AB5-001	SMOOTH CONCRETE OR ASPHALT PAVEMENT - MOST SEVERE IN-TRANSIT (BETWEEN SITES) ROAD SURFACE			STD
995-091	MEDIUM TRUCK WARRANTY			STD
A66-99D	EXPECTED FRONT AXLE(S) LOAD : 8000 0 lbs			
A68-99D	EXPECTED REAR DRIVE AXLE(S) LOAD : 17500 0 lbs			
A63-99D	EXPECTED GROSS VEHICLE WGT CAPACITY : 25500.0 lbs			
<b>Truck Service</b>				



Prepared for:  
 RON PRICE  
 HEALTH AND SAFETY STATE OF  
 WEST VIRGINIA  
 1615 WASHINGTON ST EAST  
 CHARLESTON, WV 25311  
 Phone: 304 558 0492

Prepared by:  
 Dave Meeks  
 WEST VIRGINIA TRUCK & TRAILER  
 COMPANY  
 1 Jain Dr.  
 Cross Lanes, WV 25313  
 Phone: 304-204-2435

Data Code	Description	Weight Front	Weight Rear	Retail Price
AA3-001	DRY VAN BODY			STD
AF4-99D	EXPECTED EMPTY BODY WEIGHT : 3500 0 lbs			
A88-99D	EXPECTED TRUCK BODY LENGTH : 24 0 ft			
AF6-99D	EXPECTED EMPTY BODY CG LOC FROM BODY FRT : 12 0 ft			
A89-99D	REQUESTED CAB TO TRUCK BODY CLEARANCE : 3 0			
AF7-99D	EXPECTED BODY/PAYLOAD CG HEIGHT ABOVE FRAME "XX" INCHES : 32.0			
<b>Engine</b>				
101-2HB	MBE900-280 7.2L 280 HP @ 2200 RPM, 2500 GOV, 800 LB/FT @ 1200 RPM	60		\$4 894 00
<b>Electronic Parameters</b>				
ED2-99D	ROAD SPEED LIMIT MPH : 75 0			
EC3-99D	MAX CRUISE CONTROL MPH : 70.0			
<b>Engine Equipment</b>				
99C-009	2007 EPA/CARB EMISSION CERTIFICATION			STD
105-001	ENGINE MOUNTED OIL CHECK AND FILL			STD
133-004	ONE PIECE VALVE COVER			STD
014-099	SIDE OF HOOD AIR INTAKE WITH FIREWALL MOUNTED DONALDSON AIR CLEANER			STD
124-1CA	LN 12V 160 AMP LONG BRUSH 2180 PAD MOUNT ALTERNATOR WITHOUT LAMP DRIVER	10		\$83.00
292-1D8	(2) ALLIANCE MODEL 1131, GROUP 31, 12 VOLT MAINTENANCE FREE 1850 CCA THREADED STUD BATTERIES	10		STD
290-017	BATTERY BOX FRAME MOUNTED			STD
282-003	SINGLE BATTERY BOX FRAME MOUNTED LH SIDE BACK OF CAB			N/C
291-001	FRAME GROUND RETURN FOR BATTERY CABLES			STD
289-001	NON-POLISHED BATTERY BOX COVER			STD
295-998	NO JUMP START POST			STD
107-005	WABCO 15.5 CFM AIR COMPRESSOR			N/C
131-010	STEEL AIR COMPRESSOR DISCHARGE LINE WITH INTEGRAL QUICK CONNECT SYSTEM CHARGING VALVE			N/C
152-041	ELECTRONIC ENGINE INTEGRAL SHUTDOWN PROTECTION SYSTEM			STD
016-1BH	RH INBOARD FRAME MOUNTED HORIZONTAL AFTERTREATMENT DEVICE WITH RH HORIZONTAL TAILPIPE			STD



Prepared for:  
 RON PRICE  
 HEALTH AND SAFETY STATE OF  
 WEST VIRGINIA  
 1615 WASHINGTON ST EAST  
 CHARLESTON, WV 25311  
 Phone: 304 558 0492

Prepared by:  
 Dave Meeks  
 WEST VIRGINIA TRUCK & TRAILER  
 COMPANY  
 1 Jain Dr.  
 Cross Lanes, WV 25313  
 Phone: 304-204-2435

Data Code	Description	Weight Front	Weight Rear	Retail Price
28F-002	ENGINE AFTERTREATMENT DEVICE, AUTOMATIC OVER THE ROAD REGENERATION AND DASH MOUNTED REGENERATION REQUEST SWITCH			STD
239-001	STANDARD EXHAUST SYSTEM LENGTH			STD
237-052	RH STANDARD HORIZONTAL TAILPIPE			STD
273-035	HORTON HT650 FRONTAL AIR ON/OFF ENGINE FAN CLUTCH			N/C
276-001	AUTOMATIC FAN CONTROL WITHOUT DASH SWITCH			N/C
110-040	MBE FUEL FILTER			STD
120-998	NO COOLANT FILTER			STD
266-013	1100 SQUARE INCH ALUMINUM RADIATOR	20		\$483 00
103-036	ANTIFREEZE TO -34F, ETHYLENE GLYCOL PRE-CHARGED SCA HEAVY DUTY COOLANT			STD
171-007	GATES BLUE STRIPE COOLANT HOSES			\$55 00
172-001	CONSTANT TENSION HOSE CLAMPS FOR COOLANT HOSES			STD
270-998	NO RADIATOR DRAINCOCK			STD
168-002	LOWER RADIATOR GUARD			STD
138-011	PHILLIPS-TEMRO 1000 WATT/115 VOLT BLOCK HEATER	4		\$126 00
140-053	BLACK PLASTIC ENGINE HEATER RECEPTACLE MOUNTED UNDER LH DOOR			N/C
134-001	ALUMINUM FLYWHEEL HOUSING			STD
155-058	DELCO 12V 38MT HD STARTER WITH INTEGRATED MAGNETIC SWITCH			STD

#### Transmission

342-580	ALLISON 3000 HS AUTOMATIC TRANSMISSION, NO PTO PROVISION	170	50	\$6,083 00
---------	--	-----	----	------------

#### Transmission Equipment

343-144	WTEC CALIBRATION - 6 SPEED HS (PACKAGE 200)			N/C
353-022	VEHICLE INTERFACE WIRING WITH BODY BUILDER CONNECTOR MOUNTED BACK OF CAB			\$145 00
34C-998	NO AUX/ACC TRANSMISSION WIRING			STD
362-998	NO MAIN TRANSMISSION MOUNTED PTO			STD
363-998	NO PTO MOUNTING LOCATION SPECIFIED			STD
341-018	MAGNETIC PLUGS, ENGINE DRAIN TRANSMISSION DRAIN, AXLE(S) FILL AND DRAIN			STD
345-003	PUSH BUTTON, ELECTRONIC SHIFT CONTROL, DASH MOUNTED			N/C
370-015	WATER TO OIL TRANSMISSION COOLER - IN RADIATOR END TANK			STD

Prepared for:  
 RON PRICE  
 HEALTH AND SAFETY STATE OF  
 WEST VIRGINIA  
 1615 WASHINGTON ST EAST  
 CHARLESTON, WV 25311  
 Phone: 304 558 0492

Prepared by:  
 Dave Meeks  
 WEST VIRGINIA TRUCK & TRAILER  
 COMPANY  
 1 Jain Dr.  
 Cross Lanes, WV 25313  
 Phone: 304-204-2435

Data Code	Description	Weight Front	Weight Rear	Retail Price
346-003	TRANSMISSION OIL CHECK AND FILL WITH ELECTRONIC OIL LEVEL CHECK			N/C
<b>Front Axle and Equipment</b>				
400-1EX	MFM-08-143A 8,000# FF1 SINGLE FRONT AXLE	20		\$312.00
402-021	MERITOR 15X5 Q+ CAST SPIDER CAM FRONT BRAKES DOUBLE ANCHOR, FABRICATED SHOES	20		\$187.00
403-002	NON-ASBESTOS FRONT BRAKE LINING			STD
419-021	GUNITE CAST IRON FRONT BRAKE DRUMS			N/C
427-001	FRONT BRAKE DUST SHIELDS	5		\$43.00
409-006	FRONT OIL SEALS			STD
408-001	VENTED FRONT HUB CAPS - OIL			STD
416-022	STANDARD SPINDLE NUTS FOR ALL AXLES			STD
405-002	MERITOR AUTOMATIC FRONT SLACK ADJUSTERS			N/C
536-050	TRW THP-60 POWER STEERING	10		N/C
539-003	POWER STEERING PUMP			STD
534-015	2 QUART SEE THROUGH POWER STEERING RESERVOIR			STD
<b>Front Suspension</b>				
620-015	12 000# TAPERLEAF FRONT SUSPENSION	40		\$170.00
619-005	MAINTENANCE FREE RUBBER BUSHINGS - FRONT SUSPENSION			STD
410-001	FRONT SHOCK ABSORBERS			STD
<b>Rear Axle and Equipment</b>				
420-109	RS-17-144 17,500# R-SERIES SINGLE REAR AXLE		160	\$405.00
421-557	5.57 REAR AXLE RATIO			N/C
424-001	IRON REAR AXLE CARRIER WITH STANDARD AXLE HOUSING			STD
386-013	17T MERITOR MAIN DRIVELINE WITH HALF ROUND YOKES	120	120	\$694.00
452-998	NO TRACTION EQUALIZER			STD
423-020	MERITOR 16.5X7 Q+ CAST SPIDER CAM REAR BRAKES, DOUBLE ANCHOR, FABRICATED SHOES			(\$143.00)
433-002	NON-ASBESTOS REAR BRAKE LINING			STD
434-003	STANDARD BRAKE CHAMBER LOCATION			N/C
451-023	CONMET CAST IRON REAR BRAKE DRUMS			N/C
425-002	REAR BRAKE DUST SHIELDS		5	\$63.00
440-001	CHICAGO RAWHIDE SCOTSEAL CLASSIC REAR OIL SEALS			STD
426-074	HALDEX LONG STROKE 1-DRIVE AXLE SPRING PARKING CHAMBERS			N/C



Prepared for:  
 RON PRICE  
 HEALTH AND SAFETY STATE OF  
 WEST VIRGINIA  
 1615 WASHINGTON ST EAST  
 CHARLESTON, WV 25311  
 Phone: 304 558 0492

Prepared by:  
 Dave Meeks  
 WEST VIRGINIA TRUCK & TRAILER  
 COMPANY  
 1 Jain Dr.  
 Cross Lanes, WV 25313  
 Phone: 304-204-2435

Data Code	Description	Weight Front	Weight Rear	Retail Price
428-002	MERITOR AUTOMATIC REAR SLACK ADJUSTERS			N/C
<b>Rear Suspension</b>				
622-002	20,000# FLAT LEAF REAR SPRING SUSPENSION WITH RADIUS ROD		150	\$324 00
621-001	SPRING SUSPENSION - NO AXLE SPACERS			STD
431-001	STANDARD U-BOLT PAD			STD
623-005	FORE/AFT CONTROL RODS			N/C
<b>Brake System</b>				
018-002	AIR BRAKE PACKAGE	80	140	(\$309 00)
490-100	WABCO 4S/4M ABS WITHOUT TRACTION CONTROL ENHANCEMENT			N/C
871-001	REINFORCED NYLON, FABRIC BRAID AND WIRE BRAID CHASSIS AIR LINES			N/C
412-001	STANDARD BRAKE SYSTEM VALVES			N/C
432-003	RELAY VALVE WITH 5-8 PSI CRACK PRESSURE, NO REAR PROPORTIONING VALVE			N/C
480-047	BW AD-IS (DRM) BRAKE LINE AIR DRYER WITH SHIELD, HEATER AND INTEGRAL RESERVOIR	20		\$385.00
460-001	STEEL AIR BRAKE RESERVOIRS			N/C
477-011	PETCOCK DRAIN VALVES ON ALL AIR TANK(S)			N/C
<b>Trailer Connections</b>				
335-004	UPGRADED CHASSIS MULTIPLEXING UNIT			\$98.00
32A-002	UPGRADED BULKHEAD MULTIPLEXING UNIT			STD
<b>Wheelbase &amp; Frame</b>				
545-615	6150MM (242") WHEELBASE			N/C
546-093	11/32" X 3-1/2" X 10-3/16" STEEL FRAME (8.73MM X 258.8/ 344" X 10.19") 80KSI	560	90	\$1,332 00
552-009	3050MM (120") REAR FRAME OVERHANG			N/C
55W-011	FRAME OVERHANG RANGE: 111" TO 120"	-70	290	N/C
553-001	SQUARE END OF FRAME			STD
559-001	STANDARD WEIGHT ENGINE CROSSMEMBER			STD
572-001	STANDARD REARMOST CROSSMEMBER			STD
565-001	STANDARD SUSPENSION CROSSMEMBER			STD
<b>Chassis Equipment</b>				
556-1AN	THREE-PIECE 14" STEEL CENTER BUMPER WITH FLEXIBLE PLASTIC ENDS			STD
574-001	BUMPER MOUNTING FOR SINGLE LICENSE PLATE			STD
607-001	CLEAR FRAME RAILS FROM BACK OF CAB TO FRONT REAR SUSPENSION BRACKET, BOTH RAILS OUTBOARD			N/C





Prepared for:  
 RON PRICE  
 HEALTH AND SAFETY STATE OF  
 WEST VIRGINIA  
 1615 WASHINGTON ST EAST  
 CHARLESTON, WV 25311  
 Phone: 304 558 0492

Prepared by:  
 Dave Meeks  
 WEST VIRGINIA TRUCK & TRAILER  
 COMPANY  
 1 Jain Dr.  
 Cross Lanes, WV 25313  
 Phone: 304-204-2435

Data Code	Description	Weight Front	Weight Rear	Retail Price
551-007	GRADE 8 THREADED HEX-HEADED FRAME FASTENERS			STD
<b>Fuel Tanks</b>				
206-192	50 GALLON/189 LITER RECTANGULAR ALUMINUM FUEL TANK - RH	20		\$37.00
204-192	50 GALLON/189 LITER RECTANGULAR ALUMINUM FUEL TANK - LH	70	30	\$632.00
218-005	RECTANGULAR FUEL TANK(S)			STD
215-005	PLAIN ALUMINUM/PAINTED STEEL FUEL/HYDRAULIC TANK(S) WITH PAINTED BANDS			STD
212-007	FUEL TANK(S) FORWARD			STD
205-001	FUEL TANK CAP(S)			STD
122-075	ALLIANCE FUEL FILTER/WATER SEPARATOR	15		\$80.00
216-020	EQUIFLO INBOARD FUEL SYSTEM			STD
20E-001	AUXILIARY FUEL SUPPLY AND RETURN PORTS			\$33.00
202-003	REINFORCED NYLON FUEL HOSE			STD
<b>Tires</b>				
514-006	295/75R22.5 16 PLY RADIAL FRONT TIRES			N/C
093-0JR	GOODYEAR G395 LHS 295/75R22 5 16 PLY RADIAL FRONT TIRES	6		\$476.00
516-006	295/75R22.5 16 PLY RADIAL REAR TIRES			N/C
094-0JR	GOODYEAR G395 LHS 295/75R22 5 16 PLY RADIAL REAR TIRES		12	\$952.00
<b>Hubs</b>				
418-030	CONMET IRON FRONT HUBS			N/C
450-030	CONMET IRON REAR HUBS			(\$3.00)
<b>Wheels</b>				
502-411	ACCURIDE 28408 22 5X8.25 10-HUB PILOT 2-HAND STEEL DISC FRONT WHEELS			(\$56.00)
505-411	ACCURIDE 28408 22 5X8.25 10-HUB PILOT 2-HAND STEEL DISC REAR WHEELS			(\$112.00)
<b>Cab Exterior</b>				
829-071	106" BBC FLAT ROOF ALUMINUM CONVENTIONAL CAB			STD
650-008	AIR CAB MOUNTS			\$158.00
648-002	NONREMOVABLE BUGSCREEN MOUNTED BEHIND GRILLE			\$38.00
678-001	LH AND RH GRAB HANDLES	4		\$89.00
646-009	PAINTED PLASTIC GRILLE			STD



Prepared for:  
 RON PRICE  
 HEALTH AND SAFETY STATE OF  
 WEST VIRGINIA  
 1615 WASHINGTON ST EAST  
 CHARLESTON, WV 25311  
 Phone: 304 558 0492

Prepared by:  
 Dave Meeks  
 WEST VIRGINIA TRUCK & TRAILER  
 COMPANY  
 1 Jain Dr.  
 Cross Lanes, WV 25313  
 Phone: 304-204-2435

Data Code	Description	Weight Front	Weight Rear	Retail Price
65X-001	ARGENT SILVER HOOD MOUNTED AIR INTAKE GRILLE			STD
644-004	FIBERGLASS HOOD			STD
727-1AH	SINGLE 14" ROUND POLISHED AIR HORN ROOF MOUNTED	4		\$136.00
726-001	SINGLE ELECTRIC HORN			STD
728-001	SINGLE HORN SHIELD			N/C
657-001	DOOR LOCKS AND IGNITION SWITCH KEYED THE SAME			STD
575-001	REAR LICENSE PLATE MOUNT END OF FRAME			STD
312-043	INTEGRAL HEADLIGHT/MARKER ASSEMBLY			STD
302-001	(5) AMBER MARKER LIGHTS			STD
294-001	INTEGRAL STOP/TAIL/BACKUP LIGHTS			STD
300-015	STANDARD FRONT TURN SIGNAL LAMPS			STD
744-1BG	DUAL WEST COAST MOLDED-IN COLOR HEATED MIRRORS			\$162.00
797-001	DOOR MOUNTED MIRRORS			STD
796-001	102" EQUIPMENT WIDTH			STD
743-1AP	LH AND RH 8" MOLDED-IN COLOR CONVEX MIRRORS MOUNTED UNDER PRIMARY MIRRORS			N/C
729-001	STANDARD SIDE/REAR REFLECTORS			STD
768-043	63"X14" TINTED REAR WINDOW			STD
661-003	TINTED DOOR GLASS LH AND RH WITH TINTED NON-OPERATING WING WINDOWS			STD
654-003	MANUAL DOOR WINDOW REGULATORS			STD
663-013	TINTED WINDSHIELD			STD
659-007	8 LITER WINDSHIELD WASHER RESERVOIR WITHOUT FLUID LEVEL INDICATOR			STD
<b>Cab Interior</b>				
707-1AK	OPAL GRAY VINYL INTERIOR			STD
706-013	MOLDED PLASTIC DOOR PANEL			STD
708-013	MOLDED PLASTIC DOOR PANEL			STD
772-027	GRAY VINYL MATS WITH INSULATION			STD
785-001	DASH MOUNTED ASH TRAYS AND LIGHTER			\$30.00
691-008	FORWARD ROOF MOUNTED CONSOLE WITH UPPER STORAGE COMPARTMENTS WITHOUT NETTING			STD
694-010	IN DASH STORAGE BIN			STD
742-007	(2) CUP HOLDERS LH AND RH DASH			STD
680-006	GRAY/CHARCOAL FLAT DASH			STD
720-003	5 LB. FIRE EXTINGUISHER	10		\$54.00



Prepared for:  
 RON PRICE  
 HEALTH AND SAFETY STATE OF  
 WEST VIRGINIA  
 1615 WASHINGTON ST EAST  
 CHARLESTON, WV 25311  
 Phone: 304 558 0492

Prepared by:  
 Dave Meeks  
 WEST VIRGINIA TRUCK & TRAILER  
 COMPANY  
 1 Jain Dr.  
 Cross Lanes, WV 25313  
 Phone: 304-204-2435

Data Code	Description	Weight Front	Weight Rear	Retail Price
700-002	HEATER, DEFROSTER AND AIR CONDITIONER	70		\$1 076.00
701-001	STANDARD HVAC DUCTING			STD
703-005	MAIN HVAC CONTROLS WITH RECIRCULATION SWITCH			N/C
170-015	STANDARD HEATER PLUMBING			STD
130-031	SANDEN HEAVY DUTY AIR CONDITIONER COMPRESSOR			N/C
702-002	BINARY CONTROL, R-134A			N/C
739-001	CAB INSULATION			STD
285-013	SOLID-STATE CIRCUIT PROTECTION AND FUSES			STD
280-007	12V NEGATIVE GROUND ELECTRICAL SYSTEM			STD
324-014	DOME LIGHT WITH 3-WAY SWITCH ACTIVATED BY LH AND RH DOORS			\$3 00
655-001	CAB DOOR LATCHES WITH MANUAL DOOR LOCKS			STD
722-001	TRIANGULAR REFLECTORS WITH FLARES	12		\$46 00
756-1CV	HIGH BACK NON SUSPENSION DRIVER SEAT WITH FORE AND AFT ADJUSTMENT			STD
760-1C6	HIGH BACK NON SUSPENSION PASSENGER SEAT WITH FORE AND AFT ADJUSTMENT			\$24 00
711-004	LH AND RH INTEGRAL DOOR PANEL ARMRESTS			STD
758-036	VINYL WITH VINYL INSERT DRIVER SEAT			STD
761-036	VINYL WITH VINYL INSERT PASSENGER SEAT			STD
763-032	3 POINT FIXED D-RING RETRACTOR DRIVER AND PASSENGER SEAT BELTS			STD
532-001	FIXED STEERING COLUMN			STD
540-015	4-SPOKE 18" (450MM) STEERING WHEEL			STD
765-002	DRIVER AND PASSENGER INTERIOR SUN VISORS			STD
<b>Instruments &amp; Controls</b>				
870-001	BLACK GAUGE BEZELS			STD
732-004	GRAY DRIVER INSTRUMENT PANEL			STD
734-004	GRAY CENTER INSTRUMENT PANEL			STD
486-001	LOW AIR PRESSURE LIGHT AND BUZZER			N/C
840-002	2" PRIMARY AND SECONDARY AIR PRESSURE GAUGES			N/C
198-025	INTAKE MOUNTED AIR RESTRICTION INDICATOR WITHOUT GRADUATIONS			STD
721-001	97 DB BACKUP ALARM		2	\$62 00
149-013	CRUISE CONTROL - ELECTRONIC ENGINE. WITH SWITCHES IN LH SWITCH PANEL			STD
156-007	KEY OPERATED IGNITION SWITCH AND INTEGRAL START POSITION; 4 POSITION OFF/RUN/START/ACCESSORY			STD

Prepared for:  
 RON PRICE  
 HEALTH AND SAFETY STATE OF  
 WEST VIRGINIA  
 1615 WASHINGTON ST EAST  
 CHARLESTON, WV 25311  
 Phone: 304 558 0492

Prepared by:  
 Dave Meeks  
 WEST VIRGINIA TRUCK & TRAILER  
 COMPANY  
 1 Jain Dr.  
 Cross Lanes, WV 25313  
 Phone: 304-204-2435

Data Code	Description	Weight Front	Weight Rear	Retail Price
811-011	ODOMETER/TRIP/HOUR/DIAGNOSTIC/VOLTAGE DISPLAY: 1X7 CHARACTER. 26 WARNING LAMPS DATA LINKED, ICU3			STD
160-012	DIAGNOSTIC INTERFACE CONNECTOR, 9 PIN, SAE J1587/1708/1939 LOCATED BELOW DASH			STD
844-001	2" ELECTRIC FUEL GAUGE			STD
856-001	ELECTRICAL ENGINE COOLANT TEMPERATURE GAUGE			STD
864-005	TRANSMISSION OIL TEMPERATURE INDICATOR LIGHT			STD
830-017	ENGINE AND TRIP HOUR METERS INTEGRAL WITHIN DRIVER DISPLAY			STD
852-002	ELECTRIC ENGINE OIL PRESSURE GAUGE			STD
746-1AF	AM/FM/WB RADIO	10		\$309 00
747-001	DASH MOUNTED RADIO			N/C
750-002	(2) RADIO SPEAKERS (CAB ONLY)			N/C
753-001	AM/FM ANTENNA MOUNTED ON FORWARD LH ROOF			N/C
810-027	ELECTRONIC MPH SPEEDOMETER WITH SECONDARY KPH SCALE, WITHOUT ODOMETER			STD
812-001	ELECTRONIC TACHOMETER 3000 RPM			\$104.00
162-002	IGNITION SWITCH CONTROLLED ENGINE STOP			STD
883-998	NO TRAILER HAND CONTROL BRAKE VALVE			STD
836-015	DIGITAL VOLTAGE DISPLAY INTEGRAL WITH DRIVER DISPLAY			STD
660-008	SINGLE ELECTRIC WINDSHIELD WIPER MOTOR WITH DELAY			STD
304-001	MARKER LIGHT SWITCH INTEGRAL WITH HEADLIGHT SWITCH			STD
882-009	ONE VALVE PARKING BRAKE SYSTEM WITH WARNING INDICATOR			N/C
299-013	SELF CANCELING TURN SIGNAL SWITCH WITH DIMMER, WASHER/WIPER AND HAZARD IN HANDLE			STD
298-039	INTEGRAL ELECTRONIC TURN SIGNAL FLASHER WITH HAZARD LAMPS OVERRIDING STOP LAMPS			STD

**Design**

065-000	PAINT: ONE SOLID COLOR			STD
---------	------------------------	--	--	-----

**Color**

980-3F6	CAB COLOR A: N0006EA WHITE ELITE SS			STD
986-020	BLACK. HIGH SOLIDS POLYURETHANE CHASSIS PAINT			STD
962-970	VENDOR WHITE FRONT WHEELS/RIMS			STD



Prepared for:  
 RON PRICE  
 HEALTH AND SAFETY STATE OF  
 WEST VIRGINIA  
 1615 WASHINGTON ST EAST  
 CHARLESTON, WV 25311  
 Phone: 304 558 0492

Prepared by:  
 Dave Meeks  
 WEST VIRGINIA TRUCK & TRAILER  
 COMPANY  
 1 Jain Dr.  
 Cross Lanes, WV 25313  
 Phone: 304-204-2435

Data Code	Description	Weight Front	Weight Rear	Retail Price
966-970	VENDOR WHITE REAR WHEELS/RIMS			STD
964-6Z7	BUMPER PAINT: FP24812 ARGENT SILVER DUPONT FLEX			STD

**Secondary Factory Options**

998-998	DEALER ACCEPTS RESPONSIBILITY FOR IN-SERVICE PDI INSPECTION			STD
---------	---	--	--	-----

**Sales Programs**

**TOTAL VEHICLE SUMMARY**

**Adjusted List Price**

Adjusted List Price \*\*

**Weight Summary**

Total Weight <sup>+</sup>			
Front Weight Total			6440 LBS
Rear Weight Total			4019 LBS
Total Weight			10459 LBS

**ITEMS NOT INCLUDED IN ADJUSTED LIST PRICE**

**Other Factory Charges**

PMQ-207	2007 ENGINE EMISSIONS ESCALATOR	\$6,000.00
	DELIVERY & ORDER PROCESSING CHARGE	\$1,525.00

(+) Weights shown are estimates only

If weight is critical, contact sales application engineering

(\*\*) Prices shown do not include taxes, fees etc. \*Net Equipment Selling Price is located on the Quotation Details Proposal Report



Prepared for:  
 RON PRICE  
 HEALTH AND SAFETY STATE OF  
 WEST VIRGINIA  
 1615 WASHINGTON ST EAST  
 CHARLESTON, WV 25311  
 Phone: 304 558 0492

Prepared by:  
 Dave Meeks  
 WEST VIRGINIA TRUCK & TRAILER  
 COMPANY  
 1 Jain Dr.  
 Cross Lanes, WV 25313  
 Phone: 304-204-2435

**D I M E N S I O N S**

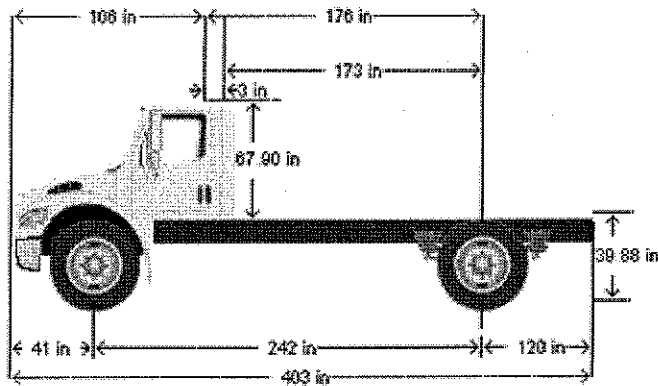

**VEHICLE SPECIFICATIONS SUMMARY - DIMENSIONS**

Model .....	M2106
Wheelbase (545) .....	6150MM (242") WHEELBASE
Rear Frame Overhang (552) .....	3050MM (120") REAR FRAME OVERHANG



Prepared for:  
 RON PRICE  
 HEALTH AND SAFETY STATE OF  
 WEST VIRGINIA  
 1615 WASHINGTON ST EAST  
 CHARLESTON, WV 25311  
 Phone: 304 558 0492

Prepared by:  
 Dave Meeks  
 WEST VIRGINIA TRUCK & TRAILER  
 COMPANY  
 1 Jain Dr.  
 Cross Lanes, WV 25313  
 Phone: 304-204-2435

Cab Size (829) ..... 106" BBC FLAT ROOF ALUMINUM CONVENTIONAL CAB  
 Sleeper (682) ..... NO SLEEPER BOX/SLEEPER CAB  
 Exhaust System (016) ..... RH INBOARD FRAME MOUNTED HORIZONTAL AFTERTREATMENT DEVICE WITH RH HORIZONTAL TAILPIPE

**TABLE SUMMARY - DIMENSIONS**

Dimensions	Inches
Bumper to Back of Cab (BBC)	106.3
Bumper to Centerline of Front Axle (BA)	40.7
Min. Cab to Body Clearance (CB)	3.0
Back of Cab to Centerline of Rear Axle(s) (CA)	178.4
Effective Back of Cab to Centerline of Rear Axle(s) (Effective CA)	173.4
Back of Cab Protrusions (Exhaust/Intake) (CP)	0.0
Back of Cab Protrusions (Side Extenders/Trim Tab) (CP)	0.0
Back of Cab Clearance (CL)	3.0
Back of Cab to End of Frame	296.4
Cab Height (CH)	67.9
Wheelbase (WB)	242.0
Frame Overhang (OH)	120.0
Overall Length (OAL)	402.7
Rear Axle Spacing	0.0
Unladen Frame Height at Centerline of Rear Axle	39.9



MOUNTAINEER TRUCK EQUIPMENT INC.  
 P. O. BOX 3588  
 CHARLESTON, WV 25335  
 304 925 6300

Current  
 Date  
 2/17/07

QUOTATION NUMBER  
 1D7900131

BILL TO:  
 WV TRUCK & Tractor

SHIP TO:  
 WV TRUCK & TRAILOR

Shipping Method: SELLER  
 FOB: RAND, WV

Reference  
 OFFICE OF MINERS  
 HEALTH, SAFETY

Terms: COD

MODEL	DESCRIPTION	QUANTITY
GVSD108524096	DRY FREIGHT INSULATED BODY	1
INSIDE HEIGHT	INSIDE LENGTH	INSIDE WIDTH
85 12"	289.56"	92.68"
		REAR DOOR OPENING
		88 00" W X 79 25" H

DESCRIPTION	QUANTITY
MISCELLANEOUS	1
THIS ORDER PROCESSED BY MORGAN BODY BUILDER	
SUBFRAME	1
1" I-BEAM CROSSMEMBERS 12" CENTERS 4" LONG RAIL-SINGLE AXLE	
SUB FRAME OPTION	1
MYLAR TAPE ON BOTTOM RAILS	
MOUNTING OPTION	1
STANDARD U-BOLT WITH FOAM BETWEEN SILLS CUSTOMER FINISH	
MUD FLAPS	2
MORGAN 24" X 36" BLACK	
INSUL-FLOOR	1
BLOCK FOAM BETWEEN SILLS-GVSDI	
THRESHOLD-REAR	1
STEEL GALVANIZED ANGLE FLUSH TO REAR	
FLOOR	1
1-3/8" LAMINATED HARDWOOD	
REAR FRAME	1
ENDPLATE REINFORCEMENT FOR 4 1/8" OR 4 3/8" ENDPLATE	
REAR FRAME	1
GALVANNEALED HEADER POST GUSSET	
REAR FRAME	1
GALVANNEALED WITH OVERHEAD DOOR AND RECHSS TAILITES	
CUSTOMER HAS REQUESTED A MORGAN VAN BODY THAT	
DOES NOT INCLUDE MORGAN STANDARD	
TRUCKSKIN-COMPATIBLE PRE-DRILLED (PLUGGED)	



DESCRIPTION	QUANTITY
HOLES IN THE REAR FRAME POSTS	
INSUL-REAR FRAME	1
FIBERGLASS INSULATION FOR REAR FRAME 85" HIGH BODY	
GRAB HANDLE	2
ALUMINUM-12' - MONOBOLIED	
CURBSIDE AND ROADSIDE REAR	
RIVETS	1
RIVETS FOR FRONT AND SIDENALL ASSEMBLIES FOR 24" BODY	
SIDE POST	1
STEEL Z ON 16" CENTERS NO DOOR CURBSIDE	
SIDE POST	1
STEEL Z ON 16" CENTERS NO DOOR ROADSIDE	
SKINS-SIDES	1
.040 ALUMINUM PREPAINTED WHITE NO DOOR	
INSUL-SIDES	2
1 5/16" POLYSIYRENE FOAM ON 16" CENTERS NO DOOR	
XXX	2
ENGINEERING SPECIAL ITEM(S)	
GLASSBOARD FULL HEIGHT NO DOOR	
FRONT END	1
AERODYNAMIC ALUMINUM RADIUS WITH STEEL Z POSTS	
SKINS-FRONT	1
.040 ALUMINUM PREPAINTED WHITE	
INSUL-CEILING	1
1 5/16" STYROFOAM WITH 1 5/16" FRONT STYROFOAM	
INSUL-FRONT	1
1 5/16" THICK STYRO-FOAM USING 1 5/16" THICK BLOCKS	
XXX	1
ENGINEERING SPECIAL ITEM	
GLASSBOARD LINER WITH 1 3/8" STYROFOAM	
INSULATION	
ROOF	1
.032 ALUMINUM GVSDI	
FRONT TOP RADIUS	1
ALUMINUM WITH RADIUS	
LINER-CEILING	1
3/32" GLASSBOARD WITH 1 3/8" CEILING FOAM AND 1 5/16" FRONT	
FOAM	
INT. LIGHT OPTION	1
EXTRA SPOT ON SAME CIRCUIT	
XXX	1
ENGINEERING SPECIAL ITEM	
SPOT WITH SWITCH AT REAR	

DESCRIPTION	QUANTITY
ICC UNERRIDE	1
center style stepwith pull out step extension	
EXT. LIGHT OPTION	1
LICENSE PLATE LITE WITH BRACKET	
EXTERIOR LIGHTS	1
PER PMV99-106 WITH SEALED HARNESS SYSTEM STANDARD	
EXT. LIGHT OPTION	1
TAILLIGHTS IN REAR CORNER POST, DOMESTIC CHASSIS	
EXT LIGHT OPTION	1
DELPHI PACKARD STYLED METRI PACK 280 SERIES CONNECTOR	
COMPONENTS USE FOR CHASSIS WIRING AND EXTERIOR LIGHTS	
INCLUDING DOME AND CLEARANCE LIGHTS	
PAINT	1
REAR FRAME STEEL WHITE IMRON	
DECALS	1
MORGAN-BLACK-FULL POINT-CUSTOMER FINISH	
ACCESSORIES	1
HACK-UR ALARM VELVAC-697087	
XXX	1
ENGINEERING SPECIAL ITEM	
SC06002851 - MAXINIZER SLIDING SIDE DOOR WITH	
RECESSED STEP WELL. 36" CLEAR OPENING WIDTH X	
80-3/16" OPENING HEIGHT LOCATE DOOR ON	
CURBSIDE AT 48" FROM INSIDE FRONT	
STEPWELL TO BE A 3-STEP ASSEMBLY WITH A	
COURTESY LIGHT IN STEPWELL	
REFERENCE DOS331, DS39122, DS99027, BPN248002,	
ILD021 AND CD248946. STEPWELL. SLIDING SIDE	
DOOR AND DOOR POCKET AREA WILL HAVE NO	
INSULATION	
XXX	1
ENGINEERING SPECIAL ITEM	
SC06002853 - SINGLE PANEL NARROW OPENING DOOR	
WITH (3) HINGES PER PANEL, POLAR 70118	
TWO-POINT HARDWARE WITH KEY LOCKING HANDLE	
WITH INSIDE HANDLE LOCATE HANDLE 41" FROM	
TOP OF ENDPLATE TO CENTER OF HANDLE SHANK	
HOLE	
REFERENCE ONLY LHW09201, NFP0031, PDR3S101	
AND AD3S550. NO INSULATION IN REAR DOOR OR IN	
REAR FRAME AREA.	

DESCRIPTION	QUANTITY
XXX ENGINEERING SPECIAL ITEM Info - FILLER PANELS FOR NARROW OPENING DOOR (44.19" W X 91.25"H) FOR CVSDI BODY WITH BLOCK FOAM AND 3/8 PLYWOOD INTERIOR LINER  INCLUDED IN PREVIOUS ITEM.	1
XXX ENGINEERING SPECIAL ITEM SC06002854 - CEILING SUPPORTS FOR A CUSTOMER SUPPLIED / CUSTOMER INSTALLED AIR CONDITIONER WITH ELECTRIC HEAT STRIPS REF: DRAWING PA69401C FOR LOCATION OF CEILING SUPPORTS  REFERENCE ONLY MISC94054	1
XXX ENGINEERING SPECIAL ITEM Manual - 16" PEAK WITH GLASSBOARD LINER AND POLYSTYRENE BLOCK FOAM SIDES AND FRONT	1

Chassis Data

Make:	Serial#:	# of Rear Axles:
Model:	Type: <u>CONV</u>	Hgt. Restric: <u>000</u>
Wheelbase:	Color:	Customer Material: <u>N</u>
Frame Width: <u>34.00</u>	Vert Exhaust: <u>N</u> Date Available:	F.O.B. _____
Pick up of Chassis: <u>N</u>	Certification: <u>N</u>	

	QUANTITY
ALUMINUM UNDERBODY STORAGE BOXES INSTALLED IN 3" CHANNEL BOXES TO BE 24"x60"x24"	3
ALUMINUM UNDERBODY STORAGE BOX INSTALLED IN 3" CHANNEL BOX TO BE 24"x30"x24"	1
7500-WATT DIESEL GENERATOR WITH ENCLOSED MOUNTING FRAME WELDED TO UNDERSIDE OF BODY.	1

ENG. NOTE: CHASSIS FRAME SHOULD BE 26' 3-5/8"  
FROM BACK OF CAB TO END OF FRAME

TOTAL DUE. ~~XXXXXXXXXX~~  
ON DELIVERY

ESTIMATED TIME OF DELIVERY FROM DATE OF RECEIPT  
OF CHASSIS \* WEEKS