



State of West Virginia  
 Department of Administration  
 Purchasing Division  
 2019 Washington Street East  
 Post Office Box 50130  
 Charleston, WV 25305-0130

**Request for  
 Quotation**

RFQ NUMBER:  
 GSD076433

PAGE:  
 1

ADDRESS CORRESPONDENCE TO ATTENTION OF:  
 KRISTA FERRELL  
 304-558-2596

\*423150715 585-924-2010  
 INDOOR AIR TECHNOLOGIES INC  
 33 WEST MAIN ST

VICTOR NY 14564  
 1.585.924.2135

DEPARTMENT OF ADMINISTRATION  
 GENERAL SERVICES DIVISION  
 BUILDING 1  
 1900 KANAWHA BOULEVARD, EAST  
 CHARLESTON, WV  
 25305 304-558-3517

DATE PRINTED: 05/23/2007	TERMS OF SALE	SHIP VIA	F.O.B.	FREIGHT TERMS
BID OPENING DATE:	06/06/2007	BID OPENING TIME		01:30PM

LINE	QUANTITY	UQP	CAT NO	ITEM NUMBER	UNIT PRICE	AMOUNT
ADDENDUM NO. 1						
THIS ADDENDUM IS ISSUED TO ANSWER QUESTIONS RAISED DURING THE MANDATORY PRE-BID MEETING, THE SITE VISIT, AND THOSE QUESTIONS SUBMITTED PRIOR TO THE MAY 21, 2007 DEADLINE PER THE ATTACHED.						
BID OPENING DATE IS EXTENDED TO: 06/06/2007						
BID OPENING TIME REMAINS: 1:30 PM						
***** END ADDENDUM NO. 1 *****						
0001	1	JB	936-10			\$15,400.00
FAN COIL AND DUCT CLEANING, MAIN CAPITOL, BLDG#1						
***** THIS IS THE END OF RFQ GSD076433 *****						TOTAL: \$15,400.00

SEE REVERSE SIDE FOR TERMS AND CONDITIONS

SIGNATURE: *[Signature]* TELEPHONE: 585-924-2010 DATE: 5/24/07  
 TITLE: President FEIN: 16-1550919 ADDRESS CHANGES TO BE NOTED ABOVE

WHEN RESPONDING TO RFQ, INSERT NAME AND ADDRESS IN SPACE ABOVE LABELED 'VENDOR'

**ADDENDUM NO. 1**  
**GSD076433**  
**ANSWERS TO QUESTIONS FROM PRE-BID**  
**MEETING/TECHNICAL QUESTIONS**

- 1.) **Clarification:** This project includes both the cleaning and sanitizing of the ductwork and associated units.
- 2.) **Q. Will linear feet of the duct be provided?**  
**A. See attached drawing for layout. Linear feet not available.**
- 3.) **Is the ductwork lined?**  
**A. No.**
- 4.) **What do you consider clean? This is a broad concept.**  
**A. Most units have front access. The Whalen units are set up a little different, but you should be able to access everything easily. GSD will provide the successful vendor with new filters to install. Vendor will discard the old filters.**
- 5.) **Clarification:** The drain pans should be 18 gauge galvanized sheet metal. Slope pan bottoms to drain.
- 6.) **Addition for Clarification:** Please add cut sheets for Whalen Units to the specifications.
- 7.) **Clarification:** Please note the two ceiling mounted fan coil units on the west soffit of the Government Organization Committee Room (Room No. 215)
- 8.) **Addition for Clarification:** Please add the attached floor plans to the specifications.

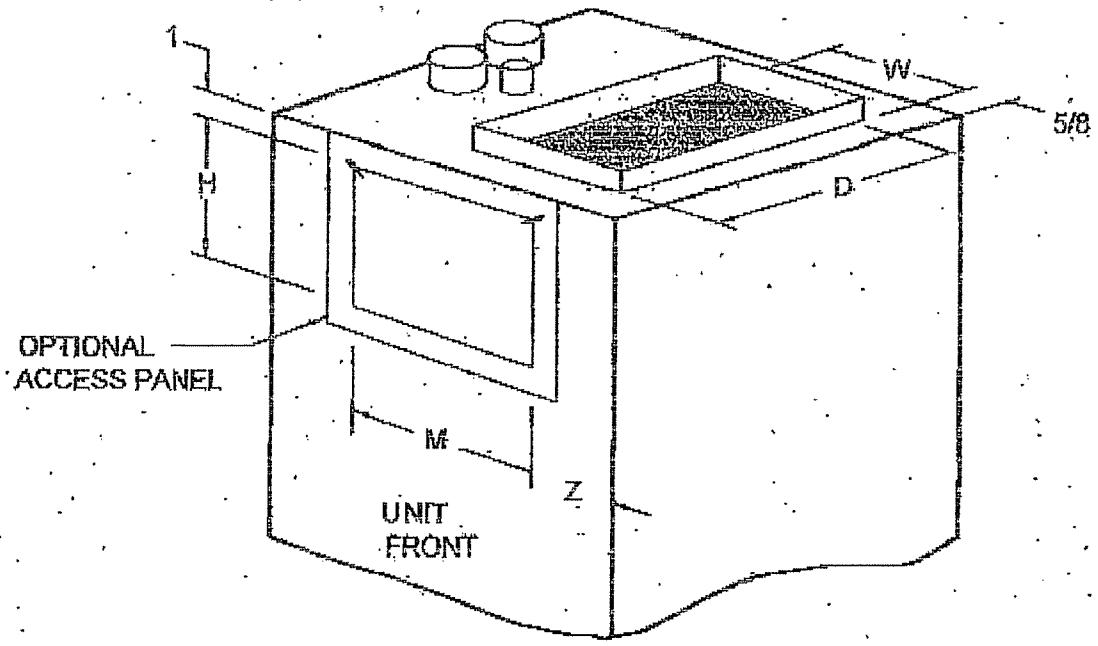

Notes:

1. See unit schedule for type of discharge arrangement.
2. Access panel is fabricated of aluminum and finished in white baked enamel.
3. Access panel is shipped loose, for installation after the drywall installation is complete.
4. Dimensions apply to standard height units only, with access panel on front or back of unit.

UNIT CFM	W	D	M	H	Z
200	6	12	10	8	1
300	6	12	10	8	1
400	8	12	10	8	3
500	8	12	10	8	3
600 FRONT	10	14	8	10	1
600 REAR	10	14	8	10	1
800 FRONT	10	14	8	10	1
800 REAR	10	14	8	10	1

All dimensions in inches.

RISER HEAT-EXCHANGER VERTICAL FAN-COIL UNITS  <b>THE WHALEN COMPANY,</b> EASTON, MARYLAND	ACCESS PANEL FOR UNITS WITH TYPE V DUCTED DISCHARGE  DRAWING NUMBER 112A
--	---

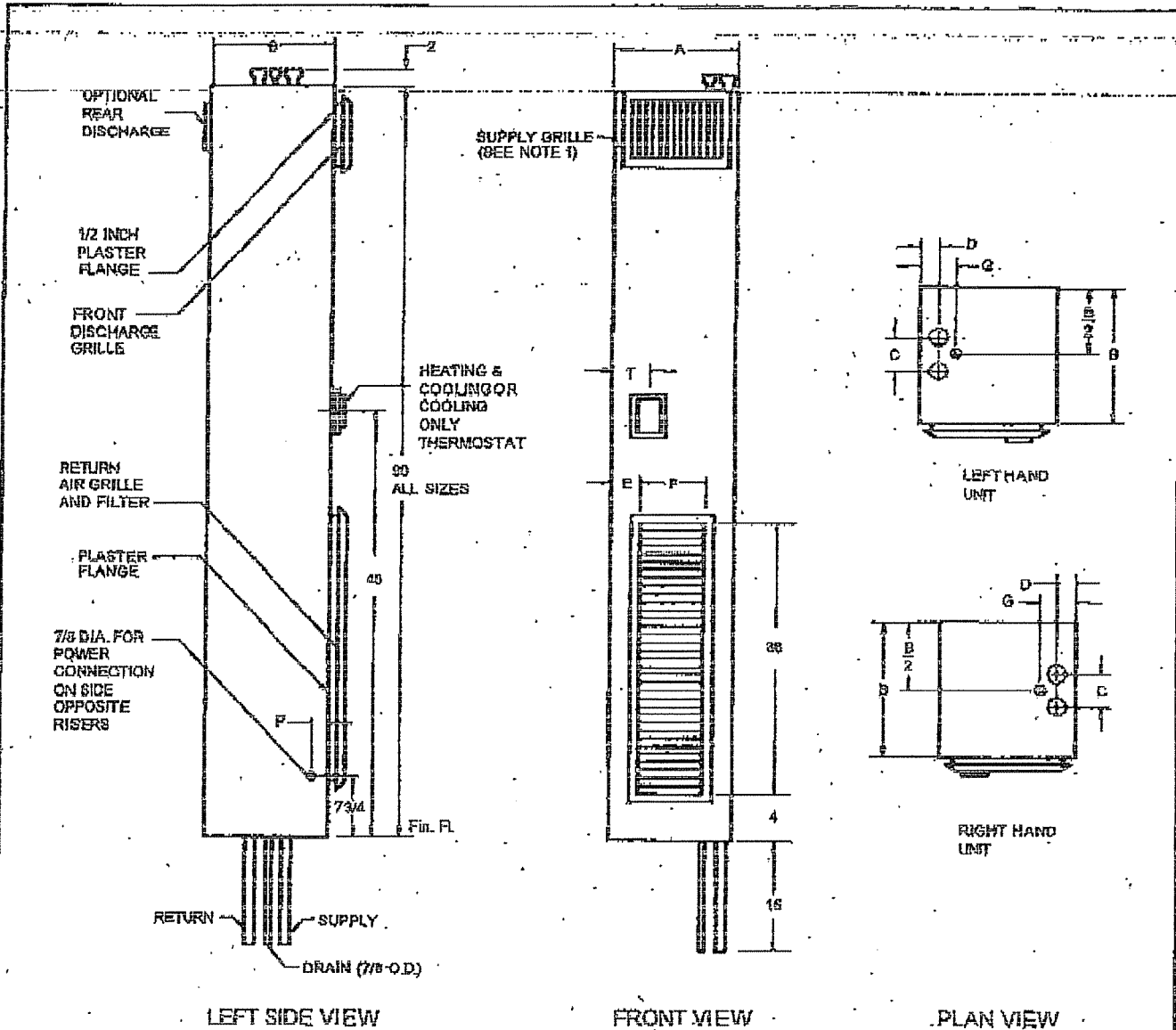

NOTES:

1. See drawing number 111 for supply grille or register options. The return air grille is always on the front of the unit.
2. Cabinet is continuous galvanized steel, suitable for direct application of "drywall" plaster board.
3. Return air grille is extruded aluminum.
4. Supply, return and drain risers are copper.
5. Fan motor is 115 volt, 60 cycle, single phase.
6. Unless otherwise noted, the fan motor runs continuously on either high or low speed.

MODEL	NOM. CFM	A	B	C	D	E	F	G	P	T	MINIMUM SLEEVE SIZE
W202F	200	12	14	2 1/2	1 1/2	2	8	2 3/4	2 1/2	3	3 1/2 X 9
W302F	300	12	14	2 1/2	1 1/2	2	8	2 3/4	2 1/2	3	3 1/2 X 5
W302XF	300	14	14	4	2 3/4	2	10	4 1/2	3	4	4 1/2 X 6
W402F	400	16	16	4	2 3/4	3	10	4 1/2	3	4	4 1/2 X 8
W502F	500	16	16	4	2 3/4	3	10	4 1/2	3	4	4 1/2 X 6
W602F	600	16	16	4	2 3/4	3	12	4 1/2	3	6	4 1/2 X 8
W802F	800	16	16	4	2 3/4	3	12	4 1/2	3	6	6 X 10

All dimensions in inches.

RISER HEAT-EXCHANGER VERTICAL FAN-COIL UNITS

THE WHALEN COMPANY  
EASTON, MARYLAND

2-PIPE HEATING/COOLING UNITS  
OR 2-PIPE COOLING ONLY UNITS  
WITH FACE & BYPASS DAMPER CONTROL

DRAWING NUMBER 102D

MARCH 1980

05

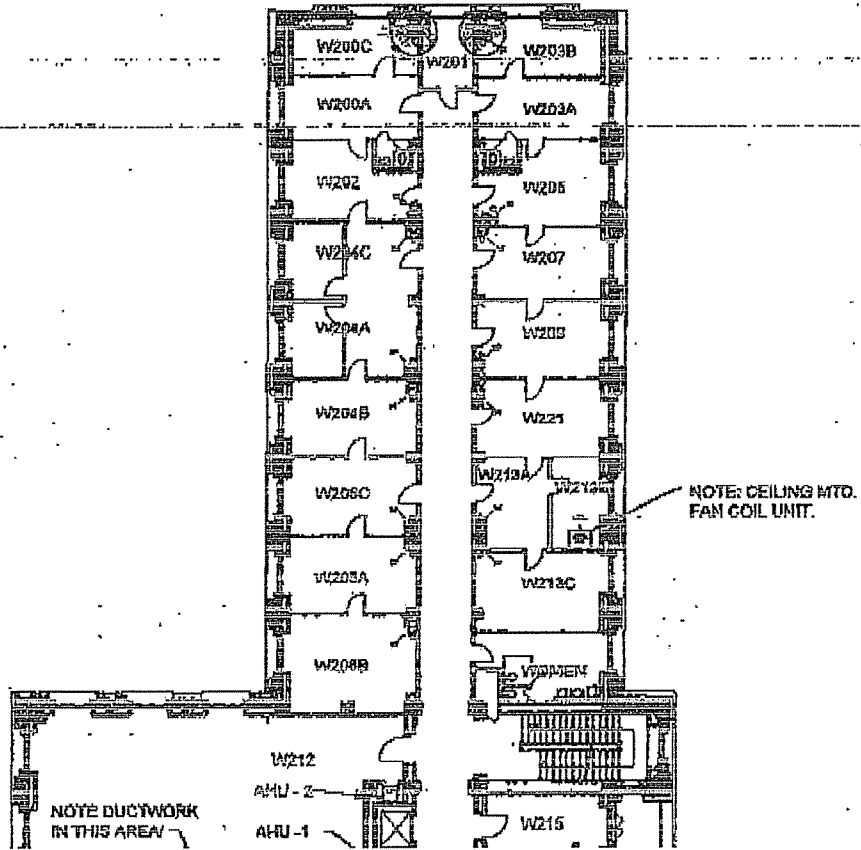

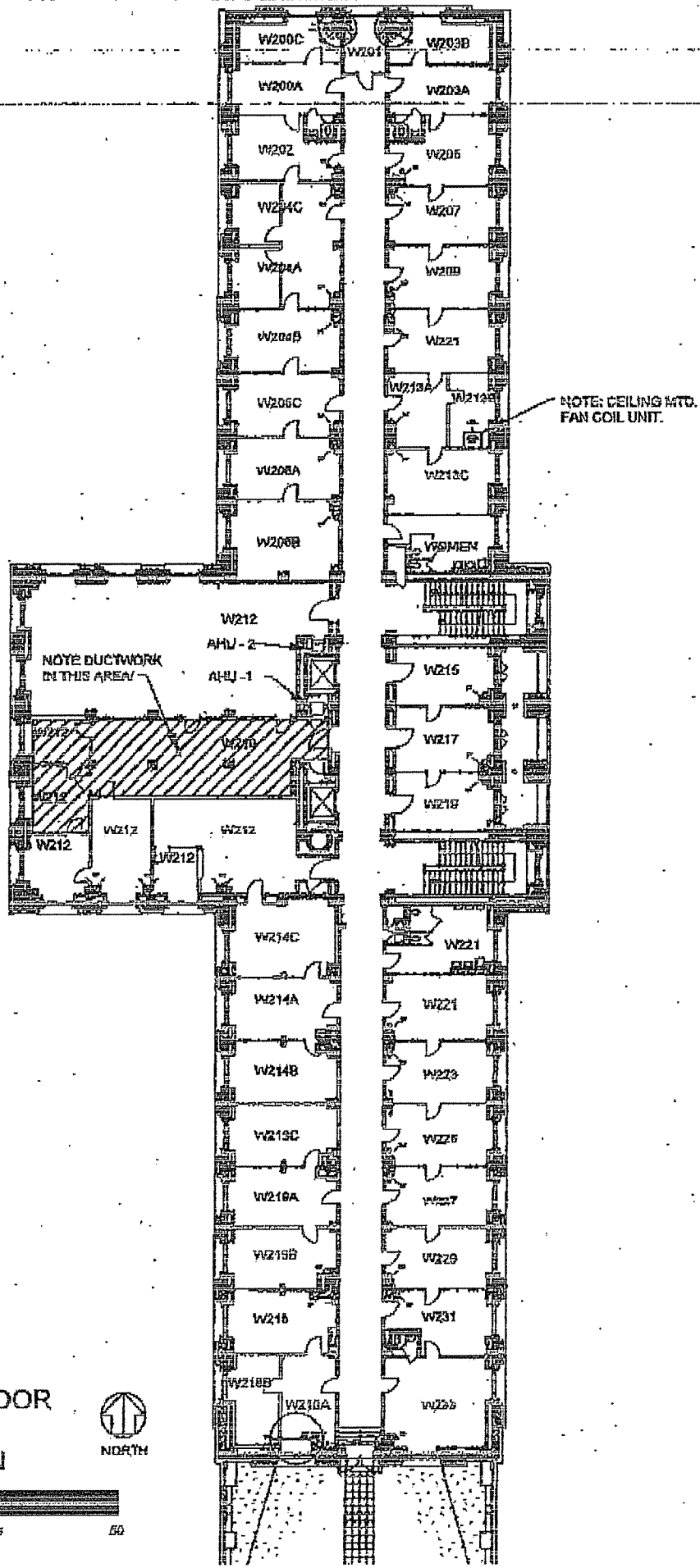

**SECOND FLOOR  
WEST WING  
FLOOR PLAN**

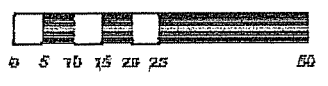

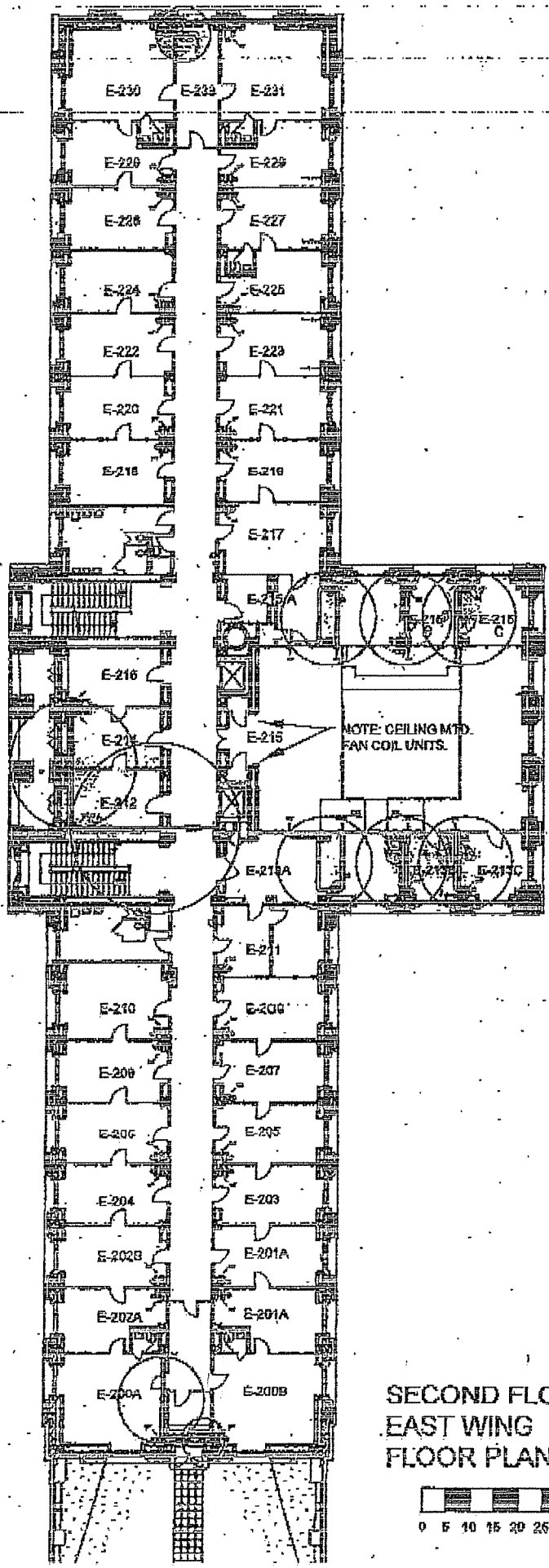

SECOND FLOOR  
EAST WING  
FLOOR PLAN

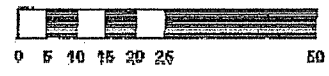

SIGN IN SHEET

Request for Quotation Number: GSD076433

Date: May 17, 2007 @ 10:00am

PLEASE PRINT LEGIBLY. THIS INFORMATION IS ESSENTIAL TO CONTACT THE ATTENDEES IN A TIMELY MANNER. FAILURE TO DO SO MAY RESULT IN DELAYS IN YOUR COMPANY GETTING IMPORTANT BID INFORMATION.

Firm Name: Fudcoe Air Tech  
 Firm Address: 33 W Main St  
Rochester, N.Y. 14564

Representative Attending: Eduard Hernandez  
 Phone Number: (585) 924-2010  
 Fax Number: (585) 924-2135  
 Email Address: eduardo@industrialtechnologies.com

Firm Name: H.E. Newpage Company  
 Firm Address: 1410 6th Avenue  
Charleston, WV 25312

Representative Attending: Tina Termini  
 Phone Number: (304) 345-5580  
 Fax Number: (304) 345-5583  
 Email Address: tjtermini@hewpage.com

Firm Name: STEVE E. GURK GREENE  
 Firm Address: 619 E MAULE AVE.  
JOHNSON CITY, TN 37601

Representative Attending: STEVE MASON  
 Phone Number: 423-926-1151  
 Fax Number: 423-926-5338  
 Email Address: STEVE@GURKGREENE.COM

Firm Name: \_\_\_\_\_  
 Firm Address: \_\_\_\_\_

Representative Attending: Krista Jendell/Purchasing  
 Phone Number: 558-2596  
 Fax Number: \_\_\_\_\_  
 Email Address: \_\_\_\_\_

Firm Name: American Clean Air  
 Firm Address: 3402 E. 7TH STREET  
MCKEESPORT, WV 26047

Representative Attending: Rick Russell  
 Phone Number: 304 485-6233  
 Fax Number: 304 485-6034  
 Email Address: rickr@cleanair.com

Firm Name: \_\_\_\_\_  
 Firm Address: \_\_\_\_\_

Representative Attending: Robert Krause  
 Phone Number: WV. GSD  
 Fax Number: \_\_\_\_\_  
 Email Address: \_\_\_\_\_

Representative Attending: SUSIE TEE/GSD  
 Phone Number: 558-0230  
 Fax Number: \_\_\_\_\_  
 Email Address: \_\_\_\_\_





State of West Virginia  
 Department of Administration  
 Purchasing Division  
 2019 Washington Street East  
 Post Office Box 50130  
 Charleston, WV 25305-0130

# Request for Quotation

RFQ NUMBER:  
**GSD076433**

PAGE:  
**1**

ADDRESS CORRESPONDENCE TO ATTENTION OF:  
**KRISTA FERRELL  
 304-558-2596**

VENDOR

\*423150715      585-924-2010  
 INDOOR AIR TECHNOLOGIES INC  
 33 WEST MAIN ST  
 VICTOR NY 14564

SHIP TO

DEPARTMENT OF ADMINISTRATION  
 GENERAL SERVICES DIVISION  
 BUILDING 1  
 1900 KANAWHA BOULEVARD, EAST  
 CHARLESTON, WV  
 25305      304-558-3517

DATE PRINTED <b>05/01/2007</b>	TERMS OF SALE	SHIP VIA	F.O.B.	FREIGHT TERMS
-----------------------------------	---------------	----------	--------	---------------

BID OPENING DATE: **05/30/2007**      BID OPENING TIME **01:30PM**

LINE	QUANTITY	UOP	CAT. NO.	ITEM NUMBER	UNIT PRICE	AMOUNT
0001	1	JB		936-10		15,400.00
<p>FAN COIL AND DUCT CLEANING, MAIN CAPITOL, BLDG#1</p> <p>REQUEST FOR QUOTATION</p> <p>THE WEST VIRGINIA PURCHASING DIVISION FOR THE AGENCY, THE WEST VIRGINIA DEPARTMENT OF ADMINISTRATION'S GENERAL SERVICE DIVISION, IS SOLICITING BIDS TO PROVIDE THE AGENCY WITH THE CLEANING OF APPROXIMATELY (73) HVAC FAN COIL UNITS, (2) AIR HANDLING UNITS, AND ASSOCIATED DUCTWORK AND LOUVERS LOCATED ON THE SECOND FLOOR OF THE EAST AND WEST WINGS OF BUILDING #1 (MAIN CAPITOL BUILDING) LOCATED ON THE CAPITOL COMPLEX IN CHARLESTON, WEST VIRGINIA PER THE ATTACHED SPECIFICATIONS.</p> <p>A MANDATORY PRE-BID MEETING IS SCHEDULED FOR MAY 17, 2007 AT 10:00 AM IN THE BASEMENT OF BUILDING #1 (RM MB-69). ALL GENERAL CONTRACTORS WISHING TO BID ON THIS PROJECT MUST ATTEND THIS MEETING. SUBCONTRACTORS AND MATERIAL SUPPLIERS ARE WELCOME, BUT NOT REQUIRED, TO ATTEND. ANY GENERAL CONTRACTOR FAILING TO ATTEND THIS MEETING WILL BE DISQUALIFIED FROM BIDDING ON THIS PROJECT. NO ONE PERSON MAY REPRESENT MORE THAN ONE VENDOR.</p> <p>ALL TECHNICAL QUESTION MUST BE SUBMITTED IN WRITING TO KRISTA FERRELL IN THE WV PURCHASING DIVISION VIA MAIL AT THE ADDRESS LISTED IN THE BODY OF THIS REQUEST FOR QUOTATION (RFQ), VIA FAX AT 304-558-4115, OR VIA EMAIL AT KFERRELL@WVADMIN.GOV. TECHNICAL</p>						

SEE REVERSE SIDE FOR TERMS AND CONDITIONS

SIGNATURE:	TELEPHONE: <b>585-924-2010</b>	DATE: <b>5/18/07</b>
TITLE: <b>President</b>	FEIN: <b>16-1550919</b>	ADDRESS CHANGES TO BE NOTED ABOVE

WHEN RESPONDING TO RFQ, INSERT NAME AND ADDRESS IN SPACE ABOVE LABELED 'VENDOR'



State of West Virginia  
 Department of Administration  
 Purchasing Division  
 2019 Washington Street East  
 Post Office Box 50130  
 Charleston, WV 25305-0130

# Request for Quotation

RFQ NUMBER  
**GSD076433**

PAGE  
**2**

ADDRESS CORRESPONDENCE TO ATTENTION OF  
**KRISTA FERRELL  
 304-558-2596**

VENDOR

\*423150715      585-924-2010  
**INDOOR AIR TECHNOLOGIES INC  
 33 WEST MAIN ST  
 VICTOR NY 14564**

SHIP TO

**DEPARTMENT OF ADMINISTRATION  
 GENERAL SERVICES DIVISION  
 BUILDING 1  
 1900 KANAWHA BOULEVARD, EAST  
 CHARLESTON, WV  
 25305      304-558-3517**

DATE PRINTED	TERMS OF SALE	SHIP VIA	F.O.B.	FREIGHT TERMS
<b>05/01/2007</b>				

BID OPENING DATE: **05/30/2007**      BID OPENING TIME **01:30PM**

LINE	QUANTITY	UOP	CAT. NO.	ITEM NUMBER	UNIT PRICE	AMOUNT
<p>QUESTIONS INCLUDE: SCOPE OF WORK, MATERIALS, LABOR, INSTALLATION, ETC. TECHNICAL QUESTIONS MAY ALSO BE SUBMITTED DURING THE MANDATORY PRE-BID MEETING. DEADLINE FOR ALL TECHNICAL QUESTIONS IS MAY 21, 2007 AT 9:00 AM.</p> <p>QUESTIONS CONCERNING THE ACTUAL SUBMISSION OF A VENDOR'S BID MAY BE SUBMITTED AT ANY TIME PRIOR TO THE BID OPENING AND IN ANY FORMAT.</p> <p>EXHIBIT 5</p> <p>NOTICE TO PROCEED: THIS CONTRACT IS TO BE PERFORMED WITHIN 90 CALENDAR DAYS AFTER THE NOTICE TO PROCEED IS RECEIVED. THE AGENCY WILL ISSUE A WRITTEN NOTICE TO PROCEED LETTER TO TO THE VENDOR.</p> <p>CANCELLATION: THE DIRECTOR OF PURCHASING RESERVES THE RIGHT TO CANCEL THIS CONTRACT IMMEDIATELY UPON WRITTEN NOTICE TO THE VENDOR IF THE MATERIALS OR WORKMANSHIP SUPPLIED ARE OF AN INFERIOR QUALITY OR DO NOT CONFORM WITH THE SPECIFICATIONS OF THE BID AND CONTRACT HERE IN.</p> <p>WAGE RATES: THE CONTRACTOR OR SUBCONTRACTOR SHALL PAY THE HIGHER OF THE U.S. DEPARTMENT OF LABOR MINIMUM WAGE RATES AS ESTABLISHED FOR KANAWHA COUNTY, PURSUANT TO WEST VIRGINIA CODE 21-5A, ET, SEQ. (PREVAILING WAGE RATES APPLY TO THIS PROJECT)</p> <p>ARBITRATION: ANY REFERENCES MADE TO ARBITRATION OR INTEREST FOR PAYMENTS DUE (EXCEPT FOR ANY INTEREST REQUIRED BY STATE LAW) CONTAINED IN THIS CONTRACT OR IN ANY AMERICAN INSTITUTE OF ARCHITECTS DOCUMENTS PERTAINING TO THIS CONTRACT ARE HEREBY DELETED.</p>						

SEE REVERSE SIDE FOR TERMS AND CONDITIONS

SIGNATURE 	TELEPHONE <b>585-924-2010</b>	DATE <b>5/18/07</b>
TITLE <b>President</b>	FEIN <b>16-0550919</b>	ADDRESS CHANGES TO BE NOTED ABOVE

WHEN RESPONDING TO RFQ, INSERT NAME AND ADDRESS IN SPACE ABOVE LABELED 'VENDOR'



State of West Virginia  
 Department of Administration  
 Purchasing Division  
 2019 Washington Street East  
 Post Office Box 50130  
 Charleston, WV 25305-0130

# Request for Quotation

RFQ NUMBER  
**GSD076433**

PAGE  
**3**

ADDRESS CORRESPONDENCE TO ATTENTION OF  
**KRISTA FERRELL  
 304-558-2596**

VENDOR

\*423150715      585-924-2010  
**INDOOR AIR TECHNOLOGIES INC**  
**33 WEST MAIN ST**  
  
**VICTOR NY 14564**

SHIP TO

**DEPARTMENT OF ADMINISTRATION  
 GENERAL SERVICES DIVISION  
 BUILDING 1  
 1900 KANAWHA BOULEVARD, EAST  
 CHARLESTON, WV  
 25305      304-558-3517**

DATE PRINTED	TERMS OF SALE	SHIP VIA	F.O.B.	FREIGHT TERMS
<b>05/01/2007</b>				

BID OPENING DATE: **05/30/2007**      BID OPENING TIME **01:30PM**

LINE	QUANTITY	UOP	CAT NO	ITEM NUMBER	UNIT PRICE	AMOUNT
<p><b>WORKERS' COMPENSATION: VENDOR IS REQUIRED TO PROVIDE A CERTIFICATE FROM WORKERS' COMPENSATION IF SUCCESSFUL.</b></p> <p><b>ALL OF THE ITEMS CHECKED BELOW WILL BE A REQUIREMENT OF THIS CONTRACT:</b></p> <p><b>(XX) INSURANCE: SUCCESSFUL VENDOR SHALL FURNISH PROOF OF COMMERCIAL GENERAL LIABILITY INSURANCE PRIOR TO ISSUANCE OF CONTRACT. UNLESS OTHERWISE SPECIFIED IN THE BID DOCUMENTS, THE MINIMUM AMOUNT OF INSURANCE COVERAGE REQUIRED IS \$250,000.</b></p> <p><b>( ) BUILDERS RISK INSURANCE: SUCCESSFUL VENDOR SHALL FURNISH PROOF OF BUILDERS RISK - ALL RISK INSURANCE IN AN AMOUNT EQUAL TO 100% OF THE AMOUNT OF THE CONTRACT.</b></p> <p><b>(XX) BONDS: FIVE PERCENT (5%) OF THE TOTAL AMOUNT OF THE BID PAYABLE TO THE STATE OF WEST VIRGINIA, SHALL B SUBMITTED WITH EACH BID AS A BID BOND. THE SUCCESSFUL BIDDER SHALL ALSO FURNISH A PERFORMANCE BOND AND LABOR/MATERIAL BOND FOR 100% OF THE AMOUNT OF THE CONTRACT. BONDS MAY BE PROVIDED IN THE FORM OF A CERTIFIED CHECK, IRREVOCABLE LETTER OF CREDIT, OR BOND FURNISHED BY A SOLVENT SURETY COMPANY AUTHORIZED TO DO BUSINESS IN TH STATE OF WEST VIRGINIA. A LETTER OF CREDIT SUBMITTED IN LIEU OF A PERFORMANCE AND LABOR &amp; MATERIAL BOND WILL ONLY BE ALLOWED FOR PROJECTS UNDER \$100,000. PERSONAL OR BUSINESS CHECKS ARE NOT ACCEPCTABLE IN LIEU OF THE 5% BID BOND, PERFORMANCE BOND, OR LABOR AND MATERIAL BOND.</b></p> <p><b>( ) MAINTENANCE BOND: A TWO (2) YEAR MAINTENANCE BOND COVERING THE ROOFING SYSTEM WILL BE A REQUIREMENT OF THE SUCCESSFUL VENDOR.</b></p> <p>REV. 11/00</p>						

SEE REVERSE SIDE FOR TERMS AND CONDITIONS

SIGNATURE 	TELEPHONE <b>585-924-2010</b>	DATE <b>5/18/07</b>
TITLE <b>President</b>	FEIN <b>16-1550919</b>	ADDRESS CHANGES TO BE NOTED ABOVE

WHEN RESPONDING TO RFQ, INSERT NAME AND ADDRESS IN SPACE ABOVE LABELED 'VENDOR'





State of West Virginia  
 Department of Administration  
 Purchasing Division  
 2019 Washington Street East  
 Post Office Box 50130  
 Charleston, WV 25305-0130

# Request for Quotation

RFQ NUMBER
GSD076433

PAGE
5

ADDRESS CORRESPONDENCE TO ATTENTION OF:
KRISTA FERRELL 304-558-2596

\*423150715 585-924-2010  
 INDOOR AIR TECHNOLOGIES INC  
 33 WEST MAIN ST  
 VICTOR NY 14564

DEPARTMENT OF ADMINISTRATION  
 GENERAL SERVICES DIVISION  
 BUILDING 1  
 1900 KANAWHA BOULEVARD, EAST  
 CHARLESTON, WV  
 25305 304-558-3517

DATE PRINTED	TERMS OF SALE	SHIP VIA	F.O.B.	FREIGHT TERMS
05/01/2007				

BID OPENING DATE: 05/30/2007 BID OPENING TIME 01:30PM

LINE	QUANTITY	UOP	CAT NO	ITEM NUMBER	UNIT PRICE	AMOUNT
<p>THAN THE LOWEST BID DOMESTIC PRODUCTS, THE SPENDING OFFICE MAY REQUEST, IN WRITING, A REEVALUATION AND REDUCTION IN THE LOWEST BID FOR SUCH DOMESTIC PRODUCTS. ALL VENDORS MUST INDICATE IN THEIR BID IF THEY ARE SUPPLYING FOREIGN ALUMINUM, GLASS OR STEEL.</p> <p>REV. 3/88</p> <p>EXHIBIT 9</p> <p>NOTICE FOR ISSUANCE &amp; ACKNOWLEDGEMENT OF CONSTRUCTION PROJECT ADDENDA</p> <p>THE ARCHITECT/ENGINEER AND/OR AGENCY SHALL BE REQUIRED TO ABIDE BY THE FOLLOWING SCHEDULE IN ISSUING CONSTRUCTION PROJECT ADDENDA FOR STATE AGENCIES:</p> <p>(1) THE ARCHITECT/ENGINEER SHALL PREPARE THE ADDENDUM AND A LIST OF ALL PARTIES THAT HAVE PROCURED DRAWINGS AND SPECIFICATIONS FOR THE PROJECT. THE ADDENDUM AND LIST SHALL BE FORWARDED TO THE BUYER IN THE STATE PURCHASING DIVISION. THE ARCHITECT/ENGINEER SHALL ALSO SEND A COPY OF THE ADDENDUM TO THE STATE AGENCY FOR WHICH THE CONTRACT IS ISSUED.</p> <p>(2) THE BUYER SHALL SEND THE ADDENDUM TO ALL INTERESTED PARTIES AND, IF NECESSARY, EXTEND THE BID OPENING DATE. ANY ADDENDUM SHOULD BE RECEIVED BY THE BUYER WITHIN FOURTEEN (14) DAYS PRIOR TO THE BID OPENING DATE.</p> <p>(3) ALL ADDENDA SHOULD BE FORMALLY ACKNOWLEDGED BY ALL BIDDERS AND SUBMITTED TO THE STATE PURCHASING DIVISION. THE SAME RULES AND REGULATIONS THAT APPLY TO THE ORIGINAL BIDDING DOCUMENT</p>						

SEE REVERSE SIDE FOR TERMS AND CONDITIONS

SIGNATURE	TELEPHONE	DATE
	585-924-2010	5/18/07
TITLE	FEIN	ADDRESS CHANGES TO BE NOTED ABOVE
President	16-1550919	

WHEN RESPONDING TO RFQ, INSERT NAME AND ADDRESS IN SPACE ABOVE LABELED 'VENDOR'



State of West Virginia  
 Department of Administration  
 Purchasing Division  
 2019 Washington Street East  
 Post Office Box 50130  
 Charleston, WV 25305-0130

# Request for Quotation

RFQ NUMBER  
**GSD076433**

PAGE  
**6**

ADDRESS CORRESPONDENCE TO ATTENTION OF  
**KRISTA FERRELL  
 304-558-2596**

\*423150715      585-924-2010  
**INDOOR AIR TECHNOLOGIES INC  
 33 WEST MAIN ST  
 VICTOR NY 14564**

**DEPARTMENT OF ADMINISTRATION  
 GENERAL SERVICES DIVISION  
 BUILDING 1  
 1900 KANAWHA BOULEVARD, EAST  
 CHARLESTON, WV  
 25305      304-558-3517**

DATE PRINTED <b>05/01/2007</b>	TERMS OF SALE	SHIP VIA	F.O.B.	FREIGHT TERMS
-----------------------------------	---------------	----------	--------	---------------

BID OPENING DATE: **05/30/2007**      BID OPENING TIME **01:30PM**

LINE	QUANTITY	UOP	CAT NO	ITEM NUMBER	UNIT PRICE	AMOUNT
<p>SHALL ALSO APPLY TO AN ADDENDUM DOCUMENT. THE ONLY EXCEPTION MAY BE FOR AN ADDENDUM THAT IS ISSUED FOR THE SOLE PURPOSE OF CHANGING A BID OPENING TIME AND/OR DATE.</p> <p>REV. 11/96</p> <p>EXHIBIT 10</p> <p>ADDENDUM ACKNOWLEDGEMENT</p> <p>I HEREBY ACKNOWLEDGE RECEIPT OF THE FOLLOWING CHECKED ADDENDUM(S) AND HAVE MADE THE NECESSARY REVISIONS TO MY PROPOSAL, PLANS AND/OR SPECIFICATION, ETC.</p> <p>ADDENDUM NOS.:</p> <p>NO. 1      5/24/07...</p> <p>NO. 2      .....</p> <p>NO. 3      .....</p> <p>NO. 4      .....</p> <p>NO. 5      .....</p> <p>I UNDERSTAND THAT FAILURE TO CONFIRM THE RECEIPT OF THE ADDENDUM(S) MAY BE CAUSE FOR REJECTION OF THE BIDS.</p> <p>.....SIGNATURE  <i>Indoor Air Technologies Inc</i>            .....COMPANY</p>						

SEE REVERSE SIDE FOR TERMS AND CONDITIONS			
SIGNATURE <i>[Signature]</i>	TELEPHONE <b>585-924-2010</b>	DATE <b>5/18/07</b>	
TITLE <b>President</b>	FEIN <b>16-1550919</b>	ADDRESS CHANGES TO BE NOTED ABOVE	

WHEN RESPONDING TO RFQ, INSERT NAME AND ADDRESS IN SPACE ABOVE LABELED 'VENDOR'



State of West Virginia  
 Department of Administration  
 Purchasing Division  
 2019 Washington Street East  
 Post Office Box 50130  
 Charleston, WV 25305-0130

# Request for Quotation

RFQ NUMBER  
**GSD076433**

PAGE  
**7**

ADDRESS CORRESPONDENCE TO ATTENTION OF  
**KRISTA FERRELL  
 304-558-2596**

PROPERTY

\*423150715      585-924-2010  
**INDOOR AIR TECHNOLOGIES INC**  
**33 WEST MAIN ST**  
**VICTOR NY 14564**

SHIP TO

**DEPARTMENT OF ADMINISTRATION  
 GENERAL SERVICES DIVISION  
 BUILDING 1  
 1900 KANAWHA BOULEVARD, EAST  
 CHARLESTON, WV  
 25305      304-558-3517**

DATE PRINTED <b>05/01/2007</b>	TERMS OF SALE	SHIP VIA	F.O.B.	FREIGHT TERMS
-----------------------------------	---------------	----------	--------	---------------

BID OPENING DATE: **05/30/2007**      BID OPENING TIME **01:30PM**

LINE	QUANTITY	UOP	CAT NO	ITEM NUMBER	UNIT PRICE	AMOUNT
<p>..... <b>5/24/07</b> ..... DATE</p> <p>REV. 11/96</p> <p style="text-align: center;"><b>CONTRACTORS LICENSE</b></p> <p>WEST VIRGINIA STATE CODE 21-11-2 REQUIRES THAT ALL PERSONS DESIRING TO PERFORM CONTRACTING WORK IN THIS STATE MUST BE LICENSED. THE WEST VIRGINIA CONTRACTORS LICENSING BOARD IS EMPOWERED TO ISSUE THE CONTRACTORS LICENSE. APPLICATIONS FOR A CONTRACTORS LICENSE MAY B MADE BY CONTACTING THE WEST VIRGINIA DIVISION OF LABOR CAPITOL COMPLEX, BUILDING 3, ROOM 319, CHARLESTON, WV 25305. TELEPHONE: (304) 558-7890.</p> <p>WEST VIRGINIA STATE CODE 21-11-11 REQUIRES ANY PROSPECTIVE BIDDER TO INCLUDE THE CONTRACTORS LICENSE NUMBER ON THEIR BID.</p> <p>BIDDER TO COMPLETE:</p> <p>CONTRACTORS NAME: <i>Indoor Air Technologies, Inc.</i></p> <p>CONTRACTORS LICENSE NO.: <i>Exempt from provisions of the West Virginia Contractor licensing law - Please see attached Certificate Provided</i></p> <p>THE SUCCESSFUL BIDDER WILL BE REQUIRED TO FURNISH A COPY OF THEIR CONTRACTORS LICENSE PRIOR TO ISSUANCE OF A PURCHASE ORDER/CONTRACT</p> <p style="text-align: center;"><b>APPLICABLE LAW</b></p> <p>THE WEST VIRGINIA STATE CODE, PURCHASING DIVISION RULES AND REGULATIONS, AND THE INFORMATION PROVIDED IN THE "REQUEST FOR QUOTATION" ISSUED BY THE PURCHASING DIVISION IS THE SOLE AUTHORITY GOVERNING THIS</p>						

SEE REVERSE SIDE FOR TERMS AND CONDITIONS

SIGNATURE 	TELEPHONE <b>585-924-2010</b>	DATE <b>5/18/07</b>
TITLE <b>President</b>	FEIN <b>16-1550919</b>	ADDRESS CHANGES TO BE NOTED ABOVE

WHEN RESPONDING TO RFQ, INSERT NAME AND ADDRESS IN SPACE ABOVE LABELED 'VENDOR'



State of West Virginia  
 Department of Administration  
 Purchasing Division  
 2019 Washington Street East  
 Post Office Box 50130  
 Charleston, WV 25305-0130

# Request for Quotation

RFQ NUMBER  
**GSD076433**

PAGE  
**8**

ADDRESS CORRESPONDENCE TO ATTENTION OF:  
**KRISTA FERRELL  
 304-558-2596**

VENDOR

\*423150715      585-924-2010  
**INDOOR AIR TECHNOLOGIES INC  
 33 WEST MAIN ST  
 VICTOR NY 14564**

SHIP TO

**DEPARTMENT OF ADMINISTRATION  
 GENERAL SERVICES DIVISION  
 BUILDING 1  
 1900 KANAWHA BOULEVARD, EAST  
 CHARLESTON, WV  
 25305      304-558-3517**

DATE PRINTED	TERMS OF SALE	SHIP VIA	F.O.B.	FREIGHT TERMS
<b>05/01/2007</b>				

BID OPENING DATE: **05/30/2007**      BID OPENING TIME **01:30PM**

LINE	QUANTITY	UOP	CAT NO.	ITEM NUMBER	UNIT PRICE	AMOUNT
<p><b>PROCUREMENT.</b></p> <p>ANY INFORMATION PROVIDED IN SPECIFICATION MANUALS, OR ANY OTHER SOURCE, VERBAL OR WRITTEN, WHICH CONTRADICTS OR ALTERS THE INFORMATION PROVIDED FROM THE SOURCES AS DESCRIBED IN THE ABOVE PARAGRAPH IS VOID AND OF NO EFFECT.</p> <p><b>BANKRUPTCY:</b> IN THE EVENT THE VENDOR/CONTRACTOR FILES FOR BANKRUPTCY PROTECTION, THIS CONTRACT IS AUTOMATICALLY NULL AND VOID, AND IS TERMINATED WITHOUT FURTHER ORDER.</p> <p>REV. 1/2005</p> <p style="text-align: center;"><b>NOTICE</b></p> <p><b>A SIGNED BID MUST BE SUBMITTED TO:</b></p> <p style="text-align: center;">DEPARTMENT OF ADMINISTRATION          PURCHASING DIVISION          BUILDING 15          2019 WASHINGTON STREET, EAST          CHARLESTON, WV 25305-0130</p> <p>THE BID SHOULD CONTAIN THIS INFORMATION ON THE FACE OF THE ENVELOPE OR THE BID MAY NOT BE CONSIDERED:</p> <p><b>SEALED BID</b></p> <p><b>BUYER:</b> KRISTA FERRELL-FILE 21</p> <p><b>REQ. NO.:</b> GSD076433</p>						

SEE REVERSE SIDE FOR TERMS AND CONDITIONS

SIGNATURE 	TELEPHONE <b>585-924-2010</b>	DATE <b>5/18/07</b>
TITLE <b>President</b>	FEIN <b>16-1550919</b>	ADDRESS CHANGES TO BE NOTED ABOVE

WHEN RESPONDING TO RFQ, INSERT NAME AND ADDRESS IN SPACE ABOVE LABELED 'VENDOR'





State of West Virginia  
 Department of Administration  
 Purchasing Division  
 2019 Washington Street East  
 Post Office Box 50130  
 Charleston, WV 25305-0130

# Request for Quotation

RFQ NUMBER  
**GSD076433**

PAGE:  
**9**

ADDRESS CORRESPONDENCE TO ATTENTION OF:  
**KRISTA FERRELL  
 304-558-2596**

**VENDOR**  
 \*423150715      585-924-2010  
**INDOOR AIR TECHNOLOGIES INC**  
**33 WEST MAIN ST**  
  
**VICTOR NY 14564**

**SHIP TO**  
 DEPARTMENT OF ADMINISTRATION  
 GENERAL SERVICES DIVISION  
 BUILDING 1  
 1900 KANAWHA BOULEVARD, EAST  
 CHARLESTON, WV  
 25305      304-558-3517

DATE PRINTED <b>05/01/2007</b>	TERMS OF SALE	SHIP VIA	F.O.B.	FREIGHT TERMS
-----------------------------------	---------------	----------	--------	---------------

BID OPENING DATE: **05/30/2007**      BID OPENING TIME **01:30PM**

LINE	QUANTITY	UOP	CAT NO.	ITEM NUMBER	UNIT PRICE	AMOUNT
BID OPENING DATE: <b>05/30/2007</b>  BID OPENING TIME: <b>1:30 PM</b>  PLEASE PROVIDE A FAX NUMBER IN CASE IT IS NECESSARY TO CONTACT YOU REGARDING YOUR BID:  ----- <b>585-924-2135</b> -----  PLEASE PRINT OR TYPE NAME OF PERSON TO CONTACT CONCERNING THIS QUOTE:  ----- <b>Rebecca S. Melton - 585-924-2010</b> -----						
***** THIS IS THE END OF RFQ GSD076433 ***** TOTAL:						<b>\$15,400.00</b>

SEE REVERSE SIDE FOR TERMS AND CONDITIONS

SIGNATURE 	TELEPHONE <b>585-924-2010</b>	DATE <b>5/18/07</b>
TITLE <b>President</b>	FEIN <b>16-1550919</b>	ADDRESS CHANGES TO BE NOTED ABOVE

WHEN RESPONDING TO RFQ, INSERT NAME AND ADDRESS IN SPACE ABOVE LABELED 'VENDOR'

State of West Virginia  
General Services Division

Building 1- East & West Wings  
Fan Coil Unit & Duct Cleaning  
Project No. GSD 076433

---

**REQUEST FOR QUOTATIONS**

**FAN COIL & DUCT CLEANING SERVICES**

**BUILDING 1- East & West Wings**

1900 Kanawha Blvd, East  
Charleston, West Virginia

Location: West Virginia State Capitol Building -  
East and West Wings  
1900 Kanawha Blvd, East  
Charleston, West Virginia 25305

For: State of West Virginia  
General Services Division  
1900 Kanawha Blvd; East  
Charleston, West Virginia 25305

All inquiries for specification clarification shall be addressed to:

Krista Ferrell, Senior Buyer  
Purchasing Division  
P. O. Box 50130  
Charleston, West Virginia 25305-0130  
Fax: (304) 558-4115  
Kferrell@wvadmin.gov

The Acquisition and Contract Administration Section of the Purchasing Division "State" for the West Virginia General Services Division is soliciting quotations to provide Fan Coil & Duct Cleaning Services.

**Scope:**

The work consists of the cleaning of approximately 73 HVAC fan coil units, two air handling units and associated ductwork and louvers located on the second floor of the east and west wings

State of West Virginia  
General Services Division

Building 1- East & West Wings  
Fan Coil Unit & Duct Cleaning  
Project No. GSD 076433

---

of the State Capitol Building. Cleaning is defined as all work necessary to remove dirt and debris from ductwork, diffusers, louvers, condensate pans, mechanical equipment and appurtenances and the disposal of associated refuse. The successful contractor shall be required keep the work area clean on a daily basis and remove debris from the site daily.

Contractor will be provided with available plans of the HVAC system. As part of this contract Contractor shall note deviations from these drawings, locations of access panels, adjustment dampers, smoke and fire dampers, valves and other as-built conditions.

Work shall be conducted as a single project with work phased on a area-by-area basis. Work in each area shall be substantially complete and inspected prior to beginning the next area or air subsystem. Submit a schedule showing the cleaning sequence, commencement and completion dates for each proposed area or subsystem. The schedule shall be reviewed and approved by the Owner prior to commencement of the work. Coordinate the schedule around Owner's work requirements.

Furnish all materials, labor, and equipment necessary to complete all work as indicated by these specifications. Intent is that the completed work consists of a fully completed fan coil & duct cleaning project. Furnish any incidental work, materials, labor and equipment that are necessary to complete the work, even if such incidental work is not explicitly included in the contract documents.

This Request for Quotations also incorporates the attached Specification "Section 15890 - Air Duct Cleaning", two attached Mechanical Floor Plan Drawings for the Building 1 East and West Wings and two .

**Pre-Bid Meeting:**

A mandatory pre-bid meeting for this project is scheduled for May 17, 2007 at 10:00 a.m. at the site. Contractors attending the meeting shall assemble in Room MB-69. This room is located in the basement of the Main Capitol Building.

**Definitions:**

- A. The Department of Administration, General Services Division, Room MB-60, State Capitol, Charleston, West Virginia shall be hereinafter called the "Owner".
- B. The service organization contracted by these specifications shall hereinafter be called the "Contractor".

State of West Virginia  
General Services Division

Building 1- East & West Wings  
Fan Coil Unit & Duct Cleaning  
Project No. GSD 076433

- C. "The Contract", as hereinstated, shall mean the agreement between the Owner and the Contractor to provide the services as herein specified.
- D. "Owners Representative", as herein stated, shall be defined as that person so designated by the Director of the General Services Division.
- E. "Architect/Engineer", as stated in the Contract shall refer to the General Services Division.

**Contract Period:**

The Contract shall be substantially completed within 90 calendar days from the issuance of the written Notice to Proceed. In accordance with the West Virginia State Code 5A-3-4(8), vendor agrees that liquidated damages shall be imposed at the rate of \$100.00 per day for failure to complete the project within the contract period. This clause shall in no way be considered exclusive and shall not limit the State or Agency's right to pursue any other additional remedy to which the State or Agency may have legal cause for action including further damages against the vendor.

**Reference Requirement:**

The qualified contractor shall have at least three years experience performing such work on projects of a similar size and type. Bidders shall supply at least three references indicating their capabilities to perform such work. References shall include the name, location, ownership and use of the building in addition to the name, address and telephone number of a contact person with the building's owner familiar with the duct cleaning work.

**Payment:**

The Contractor shall submit two copies (one original and one copy) of current invoices once each month on AIA forms G702 and G703. Invoices shall be signed in blue ink. Deliver invoices to:

General Services Division  
Attn: Business Manager  
1900 Kanawha Blvd. East  
Building 1, Room MB-60  
Charleston, West Virginia 25305

Payments shall be made monthly based on the percentage of work completed. A five percent

State of West Virginia  
General Services Division

Building 1- East & West Wings  
Fan Coil Unit & Duct Cleaning  
Project No. GSD 076433

---

(5%) retainage will be deducted until the substantial completion of the entire contract. Progress payments shall not be made when the total value of the work performed since the last estimate amounts to less than Five Hundred (\$500.00) dollars.

Submit the proposed invoice to the General Services Division - Projects / Engineering Section for approval of format prior to submission of first invoice.

**Supplementary General Conditions:**

1. The relationship of the Contractor to the Owner shall be that of an independent contractor and no principal-agent relationship or employer-employee relationship is contemplated or created by the parties to this Contract. The Contractor as an independent contractor is solely liable for the acts and omissions of its employees and agents. The Contractor shall be responsible for selecting, supervising and compensating any and all individuals employed pursuant to the terms of this contract. Neither the Contractor nor any employees or subcontractors of the Contractor shall be deemed to be employees of the State for any purposes whatsoever. The wages and salaries, taxes, withholding payments, penalties, fees, fringe benefits, professional liability insurance premiums, contributions to insurance and pension or other deferred obligations and licensing fees, etc., and the filing of all necessary documents, forms and returns pertinent to all of the foregoing are the Contractor's responsibility. The Contractor shall hold harmless the State, and shall provide the State and Agency with a defense against any and all claims including but not limited to the foregoing payments, withholdings, contributions, taxes, social security taxes, and employer income tax returns. The Contractor shall not assign, convey, transfer, sub-contract, or delegate any of its responsibilities and obligations under this contract to any person, corporation, partnership association or entity without expressed written consent of the agency.

2. Indemnification: The Contractor agrees to indemnify, defend, and hold harmless the State and the Owner, their officers, and employees from and against (1) any claims or losses for services rendered by any subcontractor, person or firm performing or supplying services, materials, or supplies in connection with the performance of the Contract; (2) Any claims or losses resulting to any person or entity injured or damaged by the Contractor, its officers, employees, or subcontractors by the publication, translation, reproduction, delivery, performance, use, or deposition of any data used under the Contract in a manner not authorized by the Contract, or by Federal or State statutes or regulations; (3) Any failure of the Contractor, its officers, employees or sub-contractors to observe State and Federal laws, including but not limited to labor and wage laws.

State of West Virginia  
General Services Division

Building 1- East & West Wings  
Fan Coil Unit & Duct Cleaning  
Project No. GSD 076433

---

3. This Contract shall be governed by the laws of the State of West Virginia. The Contractor further agrees to comply with the Civil Rights Act of 1964 and all other applicable Federal, State, and local Government regulations.
4. The Contractor shall procure all necessary permits and licenses to comply with all applicable laws, Federal, State, or municipal, along with all regulations, and ordinances of any regulating body.
5. The Contractor shall pay any applicable sales, use, or personal property taxes, arising out of this Contract and the transactions contemplated thereby. Any other taxes levied upon this Contract, the transaction, or the equipment, or services delivered pursuant hereto shall be borne by the Contractor. It is clearly understood that the State of West Virginia is exempt from any taxes regarding performance of the scope of work of this Contract.
6. Contractor shall be responsible for parts and materials as follows:
  - A. The Contractor shall supply all tools, tool accessories, personal safety equipment, and supplies necessary to execute the responsibilities of this Contract.
  - B. Contractor shall furnish a warranty of twelve (12) months for labor and materials.

**Bid Bond:**

A five percent (5%) Bid Bond is required for submission of the bid. Bonds may be provided in the form of a certified check, irrevocable letter of credit, or bond furnished by a solvent surety company authorized to do business in the state of West Virginia.

The successful bidder shall furnish a performance bond and labor/material bond for one hundred (100%) percent of the amount of the contract prior to contract award. Bonds may be provided in the form of a certified check, irrevocable letter of credit, or bond furnished by a solvent surety company authorized to do business in the state of West Virginia. A letter of credit submitted in lieu of a performance and labor/material bond will only be allowed for projects under \$100,000. Personal or business checks are not acceptable in lieu of the performance bond or labor/material bond.

**Insurance:**

Contractor shall provide evidence to the Owner of adequate coverage for Public Liability and Property Damage Insurance (\$1,000,000 minimum) to protect the Owner from any claim of

State of West Virginia  
General Services Division

Building 1- East & West Wings  
Fan Coil Unit & Duct Cleaning  
Project No. GSD 076433

---

damage, which might arise from any accident or carelessness during the life of this contract. Insurance limits shall meet insurance requirements for state projects, available from the WV Purchasing Division. All employees engaged in work under this contract shall be covered by West Virginia Worker's Compensation Insurance.

**Wage Rates:**

All employees engaged in the work of this contract shall be paid at least the minimum wage scales for the various trade classifications as established by the State Commissioner of Labor for the county where the work is being performed. All employees will be shown a copy of the wage scale for this particular area and a copy will be posted in a conspicuous place on the jobsite.

**Vendor's Number:**

The State of West Virginia will consider bids from all qualified vendors including those who do not have a current vendors certificate. Prior to the award of a contract, vendors must have a vendor's certificate and obtained a vendor's number from the Purchasing Division. Application for such certificate and vendor's number may be obtained from the Purchasing Director, Department of Finance and Administration, 2019 Washington Street, East; Charleston, West Virginia 25305. Application forms are also available from the Division of Purchasing website at [www.state.wv.us/admin/purchase](http://www.state.wv.us/admin/purchase).

**Submittals:**

All submittals for this project shall be reviewed and approved by the General Services Division Projects/Engineering Section.

**Project Closeout:**

1. Closeout documents, including marked-up as-built drawings shall be submitted in bound format prior to final application payment.
2. Final cleanup shall be completed prior to final acceptance.
3. Submit As-Built Drawings and record documents.
4. Submit "Affidavit of Payment of Debts and Claims."

State of West Virginia  
General Services Division

Building 1- East & West Wings  
Fan Coil Unit & Duct Cleaning  
Project No. GSD 076433

---

**Final Inspection:**

The Final Inspection will be conducted by an Architect / Engineer from the General Services Division, Projects / Engineering Section.

Work found to be in accordance with the Contract Documents will be accepted as complete for final acceptance. Unacceptable work, or work not in accordance with the Contract Documents shall be removed, replaced, changed or cleaned as required to meet requirements of Contract Documents prior to final acceptance. Final Acceptance does not waive or release Contractor to conform with the Contract Documents.

The date of Substantial Completion shall be determined by the Architect/Engineer conducting the final inspection based on all work being complete for final acceptance or substantially complete to permit beneficial use by the Owner. Final payment shall not be made until all work is finally accepted.

**Award Criteria:**

The State will award this Contract to the contractor meeting the mandatory requirements with the lowest overall project bid. The lowest overall project bid shall be determined by the base bid plus the unit costs of ten drain pan replacements.

**Limits of Work**

Work areas will be limited to those spaces required for access to mechanical equipment and, when applicable, to the associated ductwork.

Some mechanical room space may be utilized for temporary (overnight) storage of equipment and tools. Coordinate storage needs with the GSD Building Manager.

Owner and Agency office spaces shall remain in use during this contract. Contractor shall work with the Building Manager to coordinate the temporary access to work areas, the movement of furniture and portable partitions and otherwise provide for the Contractor needs to access ductwork. Contractor shall minimize disruption to individual work stations.



State of West Virginia  
General Services Division

Building 1- East & West Wings  
Fan Coil Unit & Duct Cleaning  
Project No. GSD 076433

---

### **Use of Facilities**

Contractor shall be permitted reasonable use of building utilities including power, water and sanitary sewage disposal as required for conducting the work. Coordinate the location of service connections or use of receptacle with the building manager to avoid overloading existing circuits.

### **Contractor Schedule:**

Provide proposed construction schedule indicating rooms and floor areas to be worked.

### **Waste Removal**

Contractor to make arrangements for the collection and disposal of Contractor's waste and construction related debris. Debris shall be removed on a daily basis.

### **Contractor Visitor Badges**

The Capitol Building is a semi-secure facility. Contractor shall provide a list of all personnel working on this project within the Building. This list shall include a copy of a valid driver's license or other legal identification and include date of birth and social security number. All proposed workers may be subjected to a criminal history / driver's license background check prior to being permitted to work in state buildings. Workers shall carry valid Contractor Photo ID Badges to be worn when working in the building. Under no circumstances shall a worker be assigned to this project without the validation first being submitted to the General Services Division and approval given.

### **Work Restrictions:**

Work shall be generally performed inside the existing building during normal business working hours of 7:00 am to 7:00 pm, Monday through Friday, except state recognized holidays.

Non-smoking building: Smoking is not permitted within the building or near entrances, operable windows or outdoor air intakes.

State of West Virginia  
General Services Division

Building 1- East & West Wings  
Fan Coil Unit & Duct Cleaning  
Project No. GSD 076433

---

### **Parking**

No parking is available near the building. The Contractor is responsible for providing all off-site parking required for the project. Contractors / workers may arrange on-site parking in available state parking lots. Provisions will be made for locating refuse dumpsters if required by the project.

### **Building Access**

The building is available from 7:00 am to 7:00 pm. Extended work hours may be acceptable if approved by the Owner. This building is a semi-secure location. Access to the building shall be coordinated with the Owner's Protective Services Division. The East Loading Dock may be utilized for periods not to exceed one-half hour to load/unload equipment and supplies but may not be used for parking or storage. Contractor shall not leave open doors unattended and shall close doors when not in use.

### **As-Built Documents:**

The Contractor will be provided with a set of the plans of the HVAC system. The original construction plans are for informational purposes only. The Owner does not warrant the accuracy or completeness of these drawings and is not responsible for deviations from these original plans.

As part of this contract the Contractor shall note deviations from the construction drawings, locations of access panels, adjustment dampers, smoke and fire dampers, and other as-built conditions. Provide a copy of these marked up drawings as part of the final project documentation.

### **Codes:**

All work is to be performed in compliance with applicable Federal and State codes including but not limited to the International Building Code, International Mechanical Code, Life Safety Code, NEC, OSHA, UL, ANSI, ASME and related standards.

State of West Virginia  
General Services Division

Building 1- East & West Wings  
Fan Coil Unit & Duct Cleaning  
Project No. GSD 076433

---

**Workmanship:**

Contractor shall complete all work in a neat and workmanlike manner. All work shall be done using new materials in a manner that meets commercial quality standards. Work shall be neat, true, plumb and square, as applicable.

**Warranty:**

Contractor shall warranty work for a period of one year from the date of Substantial Completion.

GENERAL SERVICES DIVISION

WEST VIRGINIA STATE CAPITOL  
BUILDING 1, EAST & WEST WINGS  
FAN COIL UNIT & DUCT CLEANING  
KANAWHA COUNTY, WEST VIRGINIA

BID OR PROPOSAL

Indoor Air Technologies Inc.  
NAME OF BIDDER

33 West Main St. Victor NY 14564  
ADDRESS OF BIDDER

585-924-2010  
PHONE NUMBER

Exempt from provisions of the West Virginia  
Contractor Licensing Law please see attached  
certificate provided.

5/25/07 In process per attached letter  
WV CONTRACTOR'S LICENSE NO.

We, the undersigned, having examined the site and being familiar with the local conditions affecting the cost of the work and also being familiar with the general conditions to bidders, drawings, and specifications, hereby propose to furnish all materials, equipment, and labor to complete all work in a workmanlike manner, as described in the Bidding Documents.

**BASE BID FOR CLEANING:** All labor, materials and equipment as stipulated in the Bidding Documents.

**BASE BID AMOUNT:**

Fifteen Thousand four Hundred dollars  
and zero cents — (\$15,400.<sup>00</sup>)  
(Total to be written in figures and words.)

**UNIT PRICE- DRAIN PAN REPLACEMENT:** All labor, materials and equipment as stipulated in the Bidding Documents to replace failed drain pans.

**BASE BID AMOUNT FOR EACH REPLACED PAN:**

Nine thousand five hundred dollars  
and 50 cents. — (\$ 9,500.<sup>00</sup>)  
(Total to be written in figures and words.)

**TOTAL BID (BASE BID PLUS COST OF TEN DRAIN PAN REPLACEMENTS):**

~~Thirty five thousand dollars and~~  
~~50 cents — (\$ 35,000.<sup>00</sup>)~~ RM

TOTAL  
↓

one hundred ten thousand four hundred dollars & 40 cents 110,400.<sup>00</sup> RM

The Bidder understands that to the extent allowed by the West Virginia Code, the OWNER reserves the right to waive any informality or irregularity in any Bid, or Bids, and to reject any or all Bids in whole or in part; to reject a bid not accompanied by the required bid security or by other data required by the Bidding Documents; to reject any conditions of the bid by the Bidder that is in any way inconsistent with the requirements, terms, and conditions of the Bidding Documents; or to reject a bid that is in any way incomplete or irregular.

The Bidder, if successful and awarded the contract, agrees that all work is to be complete within NINETY (90) consecutive calendar days following receipt of the OWNER'S written notice to proceed. For each calendar day of delay in achieving completion, the Contractor shall be liable for, and shall pay the OWNER liquidated damages in the amount of \$100.00 per day.

Upon receipt of the OWNER'S written notice of acceptance of this bid, the Bidder agrees that he shall execute and deliver the contract along with insurance certificates as set forth in the Bidding Documents to the OWNER within ten (10) consecutive calendar days.

When the WORK under contract has been complete and its acceptance is recommended by the OWNER, the retainage shall be released and paid to the CONTRACTOR.

**ADDENDUM ACKNOWLEDGEMENT**

I hereby acknowledge receipt of the following checked addendum and have made the necessary revisions to my proposal.

Addendum No.

#1

Date

5/24/07

I understand that failure to confirm the receipt of the Addendum may cause for rejection of bids.

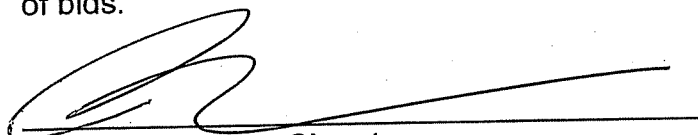
  
Signature

5/24/07  
Date

RESPECTFULLY SUBMITTED:

DATE: 5/24/07

WV VENDOR NUMBER: 423150715 Control # 85892

BY:   
(Signature in ink)

TITLE: President

FIRM NAME: Indoor Air Technologies, Inc

ADDRESS: 33 West Main St Victor NY 14564

References:

Reference Name: Platte County / Mr. John Kempf  
Position: Site Supervisor  
Address: 415 Third St. Platte City, MO 64079  
Telephone Number: 816-858-3334  
Project Name: HVAC Duct Cleaning for Platte County Courthouse / Juvenile Bldg.  
Project Description: Duct Cleaning Project

Reference Name: Tarrant County / Mr. Carl Voss or Mr. Billie Patton  
Position: Site Supervisor  
Address: 100 N. Lamar Fort Worth TX 76102  
Telephone Number: 817-884-1132 / 817-884-2854  
Project Name: Tarrant County Corrections  
Project Description: Air Conveyance System Cleaning

Reference Name: Georgia Institute of Tech / Mr. James West  
Position: Site Supervisor  
Address: 711 Marietta St Atlanta, GA 30332  
Telephone Number: 404-894-5092  
Project Name: Hemphill Ave / Center St Apts  
Project Description: Duct Cleaning Project

## SECTION 15890 - AIR DUCT CLEANING

### PART 1 - GENERAL

#### 1.1 RELATED DOCUMENTS

- A. Drawings and general provisions of the Contract, including General and Supplementary Conditions and Division 1 Specification Sections, apply to this Section.

#### 1.2 SUMMARY

- A. This Section includes cleaning of the following existing duct systems:
  - 1. Supply system.
  - 2. Return system.
  - 3. Exhaust system.
  - 4. Fan coil units

#### 1.3 DEFINITIONS

- A. ASCS: Air system cleaning specialist.
- B. NADCA: National Air Duct Cleaners Association.
- C. SMACNA: Sheet Metal and Air Conditioning Contractors' National Association.

#### 1.4 SUBMITTALS

- A. Manufacturer Certificates: Signed by manufacturers certifying that products comply with requirements.
- B. Qualification Data: For ASCS.
- C. Field quality-control test reports.

#### 1.5 QUALITY ASSURANCE

- A. ASCS Qualifications: A certified member of NADCA.
  - 1. Certification: As a minimum an ASCS certified by NADCA shall be employed on a full-time basis to supervise the project.
  - 2. Supervisor Qualifications: Certified as an ASCS by NADCA.
  - 3. Experience: Submit records of experience in the field of HVAC systems cleaning.



4. Equipment, Materials, and Labor: Have equipment, materials, and labor required to perform specified services.
- B. Comply with current published standards of NADCA.

## PART 2 - PRODUCTS

### 2.1 SHEET METAL MATERIALS

- A. Comply with SMACNA's "HVAC Duct Construction Standards - Metal and Flexible" for acceptable materials, material thicknesses, and duct construction methods, unless otherwise indicated.
- B. Galvanized-Steel Sheet: Lock-forming quality; complying with ASTM A 653/A 653M and having G60 coating designation; ducts shall have mill-phosphatized finish for surfaces exposed to view.
- C. Reinforcement Shapes and Plates: Galvanized-steel reinforcement where installed on galvanized sheet metal ducts; compatible materials for aluminum and stainless-steel ducts.

### 2.2 DUCT-MOUNTED ACCESS DOORS

- A. General Description: Fabricate doors airtight and suitable for duct pressure class.
- B. Rectangular Duct Door: Double wall; fabricated of galvanized sheet metal with insulation fill and thickness as indicated for duct pressure class. Include 1-by-1-inch butt or piano hinge and cam latches.
  1. Frame: Galvanized-steel sheet; with bendover tabs and foam gaskets.
  2. Provide number of hinges and locks as follows:
    - a. Less Than 12 Inches Square: Secure with two sash locks.
    - b. Up to 18 Inches Square: Two hinges and two sash locks.
- C. Seal around frame attachment to duct and door to frame with neoprene or foam rubber.
- D. Insulation: 1-inch thick fibrous-glass or polystyrene-foam board.

### 2.3 FLEXIBLE CONNECTORS

- A. General Description: Flame-retardant or noncombustible fabrics, coatings, and adhesives complying with UL 181, Class 1. In general, flexible connectors and ducts shall match existing.
- B. Flexible-Duct Clamps: Stainless-steel band with cadmium-plated hex screw to tighten band with a worm-gear action, in sizes 3 through 18 inches to suit duct size.

2.4 DUCT ACCESSORY HARDWARE

126

- A. Fusible Links: Replaceable, 165 deg F rated.
- B. Adhesives: High strength, quick setting, neoprene based, waterproof, and resistant to gasoline and grease.

PART 3 - EXECUTION

3.1 EXAMINATION

- A. Examine systems to determine appropriate methods, tools, and equipment required for performance of work.
- B. Prepare written report listing conditions detrimental to performance of work.
- C. Proceed with work only after unsatisfactory conditions have been corrected.

3.2 CLEANING

- A. Engage a qualified ASCS to clean the following systems:
  - 1. Supply system.
  - 2. Return system.
  - 3. Exhaust system.
  - 4. Fan coil units
- B. Perform cleaning before air balancing or mark position of dampers and air-directional mechanical devices before cleaning.
- C. Use duct-mounted access doors, as required, for physical and mechanical entry and for inspection.
  - 1. Install additional duct-mounting access doors to comply with duct cleaning standards.
  - 2. Disconnect and reconnect flexible connectors as needed for cleaning and inspection. Replace damaged and deteriorated flexible connectors.
  - 3. Reseal rigid-fiberglass-duct systems according to NAIMA recommended practices.
  - 4. Replace damaged fusible links on fire and smoke dampers. Replacement fusible links shall be same rating as those being replaced. Remove and reinstall ceiling components to gain access for duct cleaning. Clean ceiling components after they have been removed and replaced.
- D. Mark position of dampers and air-directional mechanical devices before cleaning, and restore to their marked position on completion.
- E. Particulate Collection and Odor Control:

1. Where venting vacuuming system inside building, use HEPA filtration with 99.97 percent collection efficiency for 0.3-micron size (or greater) particles.
  2. When venting vacuuming system outside building, use filtration to contain debris removed from the HVAC system and locate exhaust down wind and away from air intakes and other points of entry into building.
- F. Clean the following metal-duct system components by removing visible surface contaminants and deposits:
1. Air outlets and inlets (registers, grilles, and diffusers).
  2. Supply, return, and exhaust fans including fan housings, plenums (except ceiling supply and return plenums), scrolls, blades or vanes, shafts, baffles, dampers, and drive assemblies.
  3. Air-handling-unit internal surfaces and components including mixing box, coil section, air wash systems, condensate drain pans, humidifiers and dehumidifiers, filters and filter sections, and condensate collectors and drains.
  4. Coils and related components.
  5. Return-air ducts, dampers, and actuators, except in ceiling plenums and mechanical room.
  6. Supply-air ducts, dampers, actuators, and turning vanes.
  7. Dedicated exhaust and ventilation components.
- G. Mechanical Cleaning Methodology:
1. Clean metal-duct systems using mechanical cleaning methods that extract contaminants from within duct systems and remove contaminants from building.
  2. Use vacuum-collection devices that are operated continuously during cleaning. Connect vacuum device to downstream end of ducts so areas being cleaned are under negative pressure.
  3. Use mechanical agitation to dislodge debris adhered to interior duct surfaces without damaging integrity of metal ducts or duct liner.
  4. Clean fibrous-glass duct liner with HEPA vacuuming equipment, and do not permit duct liner to get wet. Replace fibrous-glass duct liner that is damaged, deteriorated, or delaminated or that has friable material, mold, or fungus growth.
  5. Clean coils and coil drain pans according to NADCA 1992. Keep drain pan operational. Rinse coils with clean water to remove latent residues and cleaning materials; comb and straighten fins.
  6. Provide operative drainage system for washdown procedures.
  7. Biocidal Agents and Coatings: Apply biocidal agents if fungus is present; use according to manufacturer's written instructions after removal of surface deposits and debris.
- H. Cleanliness Verification:
1. Verify cleanliness after mechanical cleaning and before application of treatment, including biocidal agents and protective coatings.
  2. Visually inspect metal-duct systems for contaminants.
  3. Where contaminants are discovered, reclean and reinspect duct systems.

### 3.3 DUCT ACCESSORIES INSTALLATION

128

- A. Install duct accessories according to applicable details in SMACNA's "HVAC Duct Construction Standards--Metal and Flexible" for metal ducts and in NAIMA AH116, "Fibrous Glass Duct Construction Standards," for fibrous-glass ducts.
- B. Provide duct accessories of materials suited to duct materials; use galvanized-steel accessories in galvanized-steel and fibrous-glass ducts, stainless-steel accessories in stainless-steel ducts, and aluminum accessories in aluminum ducts.
- C. Install duct-mounting access doors where access doors do not currently exist to allow for the cleaning of ducts, accessories, and terminal units as follows:
  1. On both sides of duct coils.
  2. Downstream from volume dampers, turning vanes, and equipment.
  3. Adjacent to fire or smoke dampers; reset or install new fusible links.
  4. Before and after each change in direction, at maximum 50-foot spacing.
  5. On sides of ducts where adequate clearance is available.
- D. Install the following sizes for duct-mounting, rectangular access doors:
  1. One-Hand or Inspection Access: 8 by 5 inches
  2. Two-Hand Access: 12 by 6 inches
  3. Head and Hand Access: 18 by 10 inches
  4. Head and Shoulders Access: 21 by 14 inches
  5. Body Access: 25 by 14 inches

### 3.4 CONNECTIONS

- A. Reconnect ducts to fans and air-handling units with existing flexible connectors after cleaning ducts and flexible connectors. Replace existing damaged and deteriorated flexible connectors.
- B. Reconnect terminal units to supply ducts with existing flexible ducts or replace damaged and deteriorated existing flexible ducts with maximum 12-inch lengths of new flexible duct.
- C. Reconnect diffusers to low-pressure ducts with existing flexible ducts or replace damaged and deteriorated existing flexible ducts with maximum 60-inch lengths of flexible duct clamped or strapped in place.
- D. Reconnect existing and new flexible ducts to metal ducts with draw bands or adhesive plus sheet metal screws.

1129

3.5 DRAIN PAN REPAIR – REPLACEMENT

- A. In cases where existing fan-coil unit drain pans have failed or where failure is likely, fabricate and install new sheet metal drain pan to match existing.
- B. Payment for new drain pans will be made on a per unit basis using the unit prices bid. Contractor shall verify the need for replacement with Owner's representative prior to approving replacement. The bid shall be based on an estimated replacement of five drain pans for each wing.

3.6 FILTERS

- A. Owner will provide contractor with new filters to be installed when unit is cleaned and placed back in service.

3.7 FIELD QUALITY CONTROL

- A. Verification of Coil Cleaning: Coil will be considered clean only if it is free of foreign matter and chemical residue, based on thorough visual inspection.
- B. Report results of tests in writing.

END OF SECTION 15890

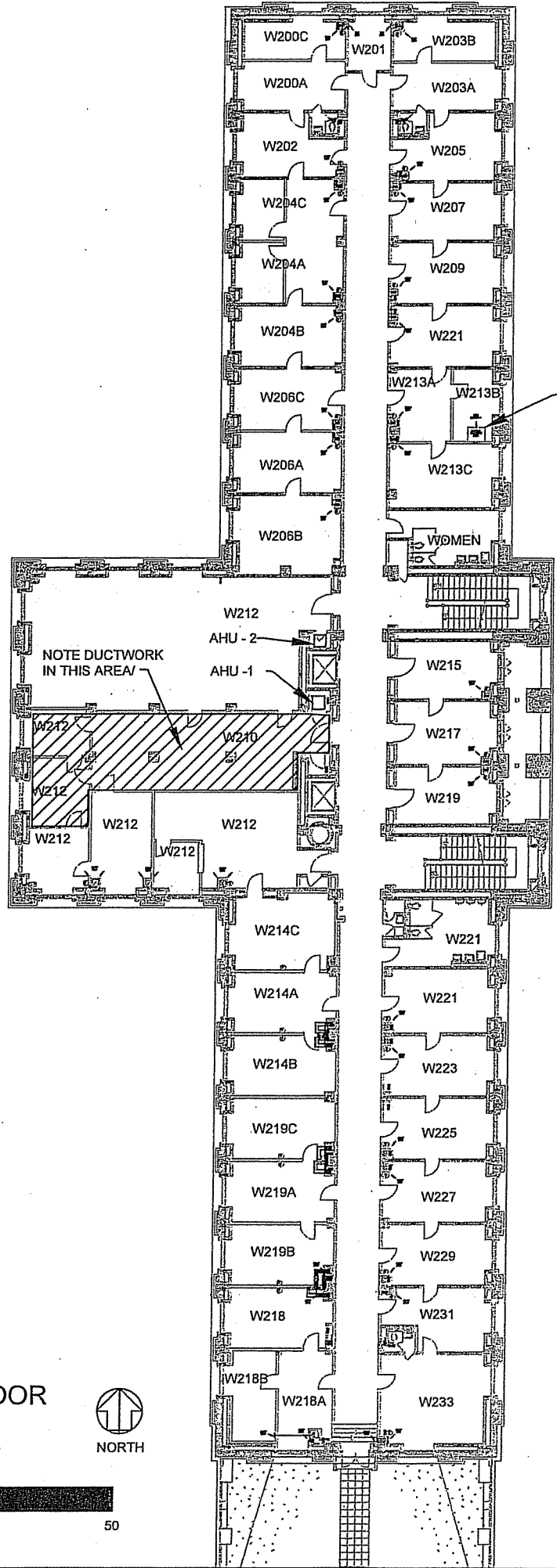

NOTE: CEILING MTD.  
FAN COIL UNIT.

NOTE DUCTWORK  
IN THIS AREA

SECOND FLOOR  
WEST WING  
FLOOR PLAN

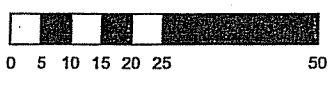

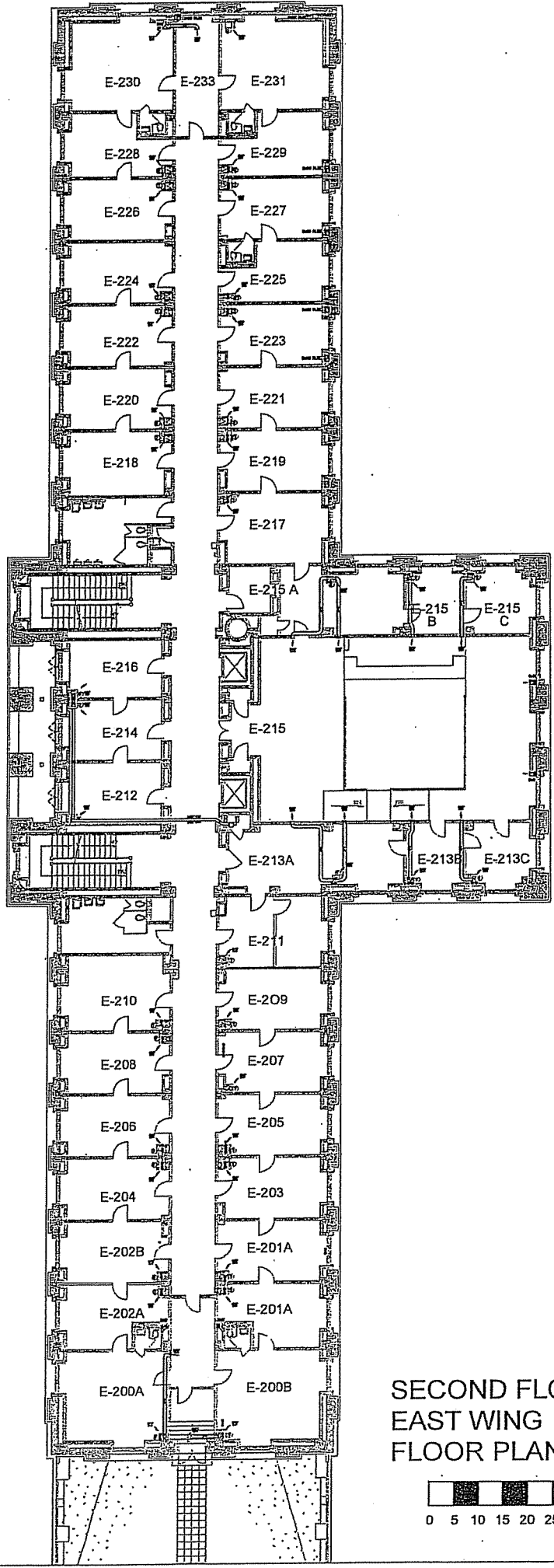

SECOND FLOOR  
EAST WING  
FLOOR PLAN

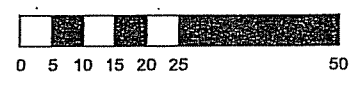

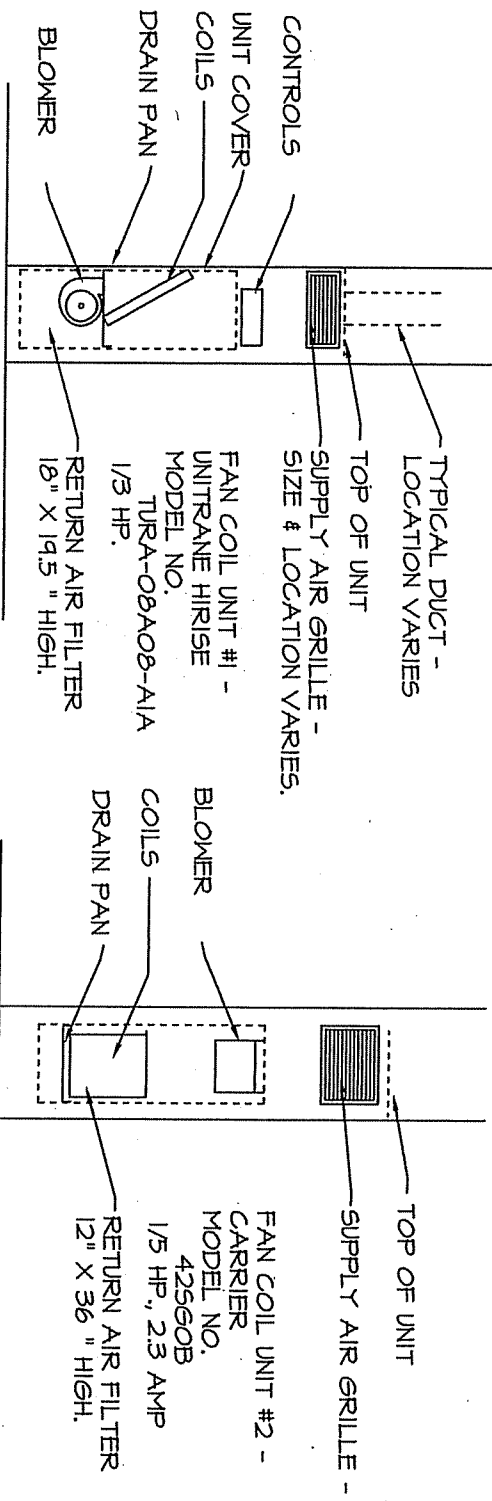

# WEST MINGE - FAN COIL UNITS





NOTE: COIL ACCESS THROUGH RETURN & SUPPLY AIR GRILLES.

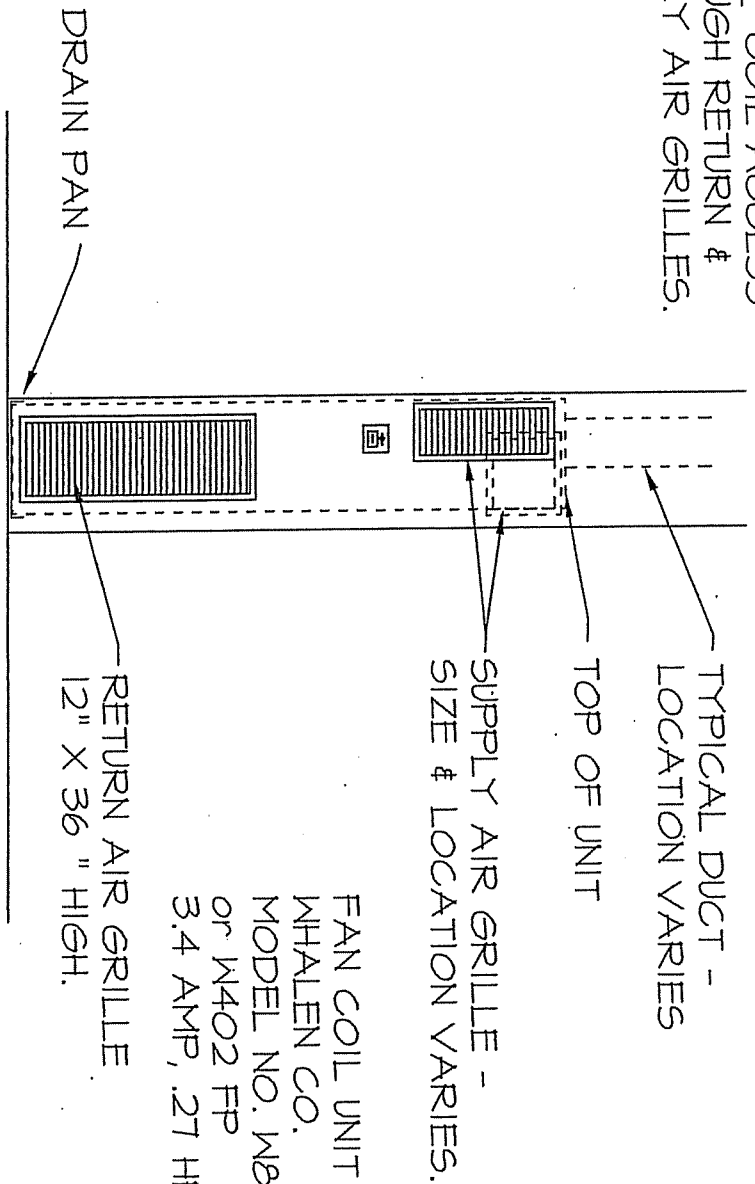

FAN COIL UNIT -  
MHALEN CO.  
MODEL NO. W802 FP  
or W402 FP  
3.4 AMP, .27 HP.

# EAST WING - FAN COIL UNITS



BID BOND

34

KNOW ALL MEN BY THESE PRESENTS, That we, the undersigned, \_\_\_\_\_  
of \_\_\_\_\_, \_\_\_\_\_, as Principal, and \_\_\_\_\_  
of \_\_\_\_\_, \_\_\_\_\_, a corporation organized and existing under the laws of the State of \_\_\_\_\_  
with its principal office in the City of \_\_\_\_\_, as Surety, are held and firmly bound unto the State  
of West Virginia, as Obligee, in the penal sum of \_\_\_\_\_ (\$ \_\_\_\_\_) for the payment of which,  
well and truly to be made, we jointly and severally bind ourselves, our heirs, administrators, executors, successors and assigns.

The Condition of the above obligation is such that whereas the Principal has submitted to the Purchasing Section of the  
Department of Administration a certain bid or proposal, attached herelo and made a part hereof, to enter into a contract in writing for  
\_\_\_\_\_  
\_\_\_\_\_  
\_\_\_\_\_

NOW THEREFORE,

- (a) If said bid shall be rejected, or
- (b) If said bid shall be accepted and the Principal shall enter into a contract in accordance with the bid or proposal attached  
herelo and shall furnish any other bonds and insurance required by the bid or proposal, and shall in all other respects perform the  
agreement created by the acceptance of said bid, then this obligation shall be null and void, otherwise this obligation shall remain in full  
force and effect. It is expressly understood and agreed that the liability of the Surety for any and all claims hereunder shall, in no event,  
exceed the penal amount of this obligation as herein stated.

The Surety, for the value received, hereby stipulates and agrees that the obligations of said Surety and its bond shall be in no  
way impaired or affected by any extension of the time within which the Obligee may accept such bid, and said Surety does hereby  
give notice of any such extension.

IN WITNESS WHEREOF, Principal and Surety have hereunto set their hands and seals, and such of them as are corporations  
have caused their corporate seals to be affixed hereunto and these presents to be signed by their proper officers, this  
\_\_\_\_\_ day of \_\_\_\_\_, 20\_\_\_\_.

Principal Corporate Seal

\_\_\_\_\_  
(Name of Principal)

By \_\_\_\_\_  
(Must be President or  
Vice President)

\_\_\_\_\_  
(Title)

\_\_\_\_\_  
(Name of Surety)

\_\_\_\_\_  
Attorney-in-Fact

Surety Corporate Seal

NOTICE - Surety executing bonds must be licensed in West Virginia to transact surety insurance. Corporate seals must be affixed,  
and power of attorney must be attached.

BID BOND PREPARATION INSTRUCTIONS

AGENCY (A)  
RFQ/RFP# (B)

1135

Bid Bond

- (A) WV State Agency  
(Stated on Page 1 "Spending Unit")  
Request for Quotation Number (upper right corner of page #1)
- (C) Your Company Name
- (D) City, Location of your Company
- (E) State, Location of your Company
- (F) Surety Corporate Name
- (G) City, Location of Surety
- (H) State, Location of Surety
- (I) State of Surety Incorporation
- (J) City of Surety Incorporation
- (K) Minimum amount of acceptable bid bond is 5% of total bid. You may state "5% of bid" or a specific amount on this line in words.
- (L) Amount of bond in figures
- (M) Brief Description of scope of work
- (N) Day of the month
- (O) Month
- (P) Year
- (Q) Name of Corporation
- (R) Raised Corporate Seal of Principal
- (S) Signature of President or Vice President
- (T) Title of person signing
- (U) Raised Corporate Seal of Surety
- (V) Corporate Name of Surety
- (X) Signature of Attorney in Fact of the Surety

NOTE: Dated, Power of Attorney with Raised Surety Seal must accompany this bid bond.

KNOW ALL MEN BY THESE PRESENTS, That we, the undersigned, (C) of (D), (E) as Principal, and (F) of (G), (H), a corporation organized and existing under the laws of the State of (I) with its principal office in the City of (J), as Surety, are held and firmly bound unto The State of West Virginia, as Obligee, in the penal sum of (K) (\$ (L)) for the payment of which, well and truly to be made, we jointly and severally bind ourselves, our heirs, administrators, executors, successors and assigns.

The Condition of the above obligation is such that whereas the Principal has submitted to the Purchasing Section of the Department of Administration a certain bid or proposal, attached hereto and made a part hereof to enter into a contract in writing for (M)

NOW THEREFORE.

- (a) If said bid shall be rejected, or
- (b) If said bid shall be accepted and the Principal shall enter into a contract in accordance with the bid or proposal attached hereto and shall furnish any other bonds and insurance required by the bid or proposal, and shall in all other respects perform the agreement created by the acceptance of said bid then this obligation shall be null and void, otherwise this obligation shall remain in full force and effect. It is expressly understood and agreed that the liability of the Surety for any and all claims hereunder shall, in no event, exceed the penal amount of this obligation as herein stated

The Surety for value received, hereby stipulates and agrees that the obligations of said Surety and its bond shall be in no way impaired or affected by any extension of time within which the Obligee may accept such bid: and said Surety does hereby waive notice of any such extension.

IN WITNESS WHEREOF, Principal and Surety have hereunto set their hands and seals, and such of them as are corporations have caused their corporate seals to be affixed hereto and these presents to be signed by their proper officers, this (N) day of (O), 20 (P).

Principal Corporate Seal

(R)

(Q)  
(Name of Principal)  
By (S)  
(Must be President or Vice President)

(T)  
Title

Surety Corporate Seal

(U)

(V)  
(Name of Surety)

(X)  
Attorney-in-Fact

IMPORTANT - Surety executing bonds must be licensed in West Virginia to transact surety insurance. Corporate seals must be affixed, a power of attorney must be attached.

STATE OF WEST VIRGINIA  
Purchasing Division

136

**PURCHASING AFFIDAVIT**

**West Virginia Code §5A-3-10a states:** No contract or renewal of any contract may be awarded by the state or any of its political subdivisions to any vendor or prospective vendor when the vendor or prospective vendor or a related party to the vendor or prospective vendor is a debtor and the debt owned is an amount greater than one thousand dollars in the aggregate

**DEFINITIONS:**

"Debt" means any assessment, premium, penalty, fine, tax or other amount of money owed to the state or any of its political subdivisions because of a judgment, fine, permit violation, license assessment, defaulted workers' compensation premium, penalty or other assessment presently delinquent or due and required to be paid to the state or any of its political subdivisions, including any interest or additional penalties accrued thereon.

"Debtor" means any individual, corporation, partnership, association, limited liability company or any other form or business association owing a debt to the state or any of its political subdivisions. "Political subdivision" means any county commission; municipality; county board of education; any instrumentality established by a county or municipality; any separate corporation or instrumentality established by one or more counties or municipalities, as permitted by law; or any public body charged by law with the performance of a government function or whose jurisdiction is coextensive with one or more counties or municipalities. "Related party" means a party, whether an individual, corporation, partnership, association, limited liability company or any other form or business association or other entity whatsoever, related to any vendor by blood, marriage, ownership or contract through which the party has a relationship of ownership or other interest with the vendor so that the party will actually or by effect receive or control a portion of the benefit, profit or other consideration from performance of a vendor contract with the party receiving an amount that meets or exceeds five percent of the total contract amount.

**EXCEPTION:** The prohibition of this section does not apply where a vendor has contested any tax administered pursuant to chapter eleven of this code, workers' compensation premium, permit fee or environmental fee or assessment and the matter has not become final or where the vendor has entered into a payment plan or agreement and the vendor is not in default of any of the provisions of such plan or agreement.

**LICENSING:** Vendors must be licensed and in good standing in accordance with any and all state and local laws and requirements by any state or local agency of West Virginia, including, but not limited to, the West Virginia Secretary of State's Office, the West Virginia Tax Department, West Virginia Insurance Commission, or any other state agencies or political subdivision. Furthermore, the vendor must provide all necessary releases to obtain information to enable the Director or spending unit to verify that the vendor is licensed and in good standing with the above entities.

**CONFIDENTIALITY:** The vendor agrees that he or she will not disclose to anyone, directly or indirectly, any such personally identifiable information or other confidential information gained from the agency, unless the individual who is the subject of the information consents to the disclosure in writing or the disclosure is made pursuant to the agency's policies, procedures and rules. Vendors should visit [www.state.wv.us/admin/purchase/privacy](http://www.state.wv.us/admin/purchase/privacy) for the Notice of Agency Confidentiality Policies.

Under penalty of law for false swearing (West Virginia Code, §61-5-3), it is hereby certified that the vendor acknowledges the information in this said affidavit and are in compliance with the requirements as stated.

Vendor's Name: Indoor Air Technologies Inc.

Authorized Signature: Rebecca Melton Date: 5/18/07  
President

May 25, 2007

**Via Facsimile (585) 924-2135  
And Regular Mail**

Jennifer English  
Indoor Air Technologies  
33 West Main Street  
Victor, NY 14564

Dear Ms. English:

Our office has received information, including a scope of work, regarding a job for the West Virginia Department of Tax & Revenue. After review of the information submitted and conversations with an Engineer with the State of West Virginia, it has been determined that the exemption issued by our office is null and void. Your company will be required to hold a West Virginia HVAC Contractor License to perform any work within the State.

Someone from your company will be required to successful pass the Business and Law examination and the HVAC examination. The tested person can be a full time employee, corporate officer, partner, member or owner of Indoor Air Technologies.

Should you have further questions, please do not hesitate to contact Amy Smith, at (304) 558-7890 extension 118 or by email at [asmith@labor.state.wv.us](mailto:asmith@labor.state.wv.us)

Sincerely,



Fran Cook  
Deputy Commissioner  
FC:amy

cc: Steven R. Bratke, Esquire (via facsimile 304-422-7196)  
Robert P. Krause, WV General Services Division  
(via facsimile – 304-558-1928)

*Law Process*

**CHAIRMAN**  
MICHAELA CARL

**MEMBERS**  
GENE THOMPSON  
RANDY FERGUSON  
CLIFFORD GILLILAN  
KENNETH TUBBS  
JANET WHIPKEY  
BOB ARMSTRONG  
JOHN CASTO  
WILLIAM HARMON  
JOHN STRICKLAND

**EX-OFFICIO MEMBERS**  
DAVID W. MULLINS

# WEST VIRGINIA DIVISION OF LABOR

749-B Building 6, Capitol Complex • Charleston, West Virginia 25305

Phone (304) 558-7890 • Fax (304) 558-3797

HTTP://WWW.LABOR.STATE.WV.US

JOE MANCHIN, III  
Governor



DAVID W. MULLINS  
Commissioner

## WEST VIRGINIA CONTRACTOR LICENSING BOARD

Building 6, Room B-749, Capitol Complex  
Charleston, West Virginia 25305

March 6, 2007

### EXEMPTION FROM THE REQUIREMENTS OF THE CONTRACTOR LICENSING ACT

---

The following company has demonstrated through a letter of explanation that due to the nature of business being conducted, the company is exempt from provisions of the West Virginia Contractor Licensing Law.

Indoor Air Technologies  
33 West Main Street  
Victor, NY 14564

#### TYPE OF WORK PERFORMED....

"Company will clean the duct work in buildings ONLY."

---

This exemption does not apply to work, which is subject to State Building Codes and National Fire Protection Association codes.

This exemption expires: March 6, 2008

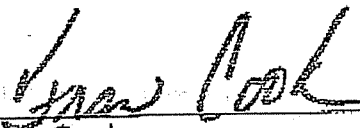
  
\_\_\_\_\_  
Fran Cook  
Deputy Commissioner

\* To renew this exemption, please fax it to (304) 558-2273 to the attention of AMY \*

# State of West Virginia



## Certificate

*I, Betty Ireland, Secretary of State of the State of West Virginia, hereby certify that*

**INDOOR AIR TECHNOLOGIES, INC.**

**Control Number: 85892**

a corporation formed under the laws of New York

has filed its "Application for Certificate of Authority" to transact business in West Virginia as required by the provisions of the West Virginia Code. I hereby declare the organization to be registered as a foreign corporation from its effective date of June 9, 2006

Therefore, I issue this

### CERTIFICATE OF AUTHORITY

to the corporation authorizing it to transact business in West Virginia

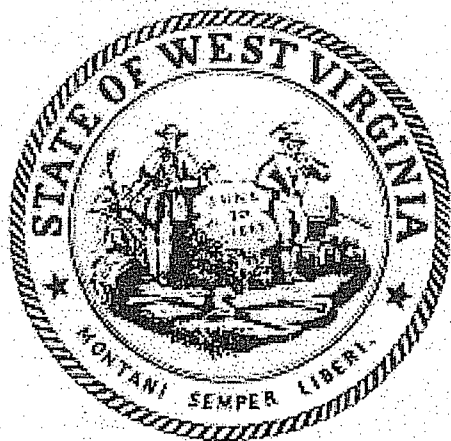

*Given under my hand and the  
Great Seal of the State of  
West Virginia on this day of  
June 9, 2006*

*Betty Ireland*

*Secretary of State*