



State of West Virginia  
 Department of Administration  
 Purchasing Division  
 2019 Washington Street East  
 Post Office Box 50130  
 Charleston, WV 25305-0130

# Request for Quotation

RFO NUMBER
COR61336

PAGE
1

ADDRESS CORRESPONDENCE TO ATTENTION OF:
JOHN ABBOTT 304-558-2544

VENDOR

\*709035634      304-346-0521  
 HOOTEN EQUIPMENT COMPANY LLC  
 PO BOX 109  
  
 CHARLESTON WV 25321

SHIP TO

DIVISION OF CORRECTIONS  
  
 617 LEON SULLIVAN WAY  
  
 CHARLESTON, WV  
 25301      304-558-8045

DATE PRINTED	TERMS OF SALE	SHIP VIA	F.O.B.	FREIGHT TERMS
02/12/2007	NET		Destination	
BID OPENING DATE: 03/08/2007		BID OPENING TIME 01:30PM		

LINE	QUANTITY	UOP	CAT NO	ITEM NUMBER	UNIT PRICE	AMOUNT
REQUEST FOR QUOTATION						
THE PURCHASING DIVISION IS SOLICITING BIDS FOR THE DIVISION OF CORRECTIONS TO PROVIDE CAFETERIA / KITCHEN EQUIPMENT FOR THE MT. OLIVE CORRECTIONAL CENTER.						
MANDATORY ON-SITE PRE-BID: 02/28/2007; 2:30 PM REGISTER BY 2/26/2007, BY CONTACTING TIM WHITTINGTON AT 304-442-7216.						
ATTACHMENTS: 1. SPECIFICATIONS 2. AFFIDAVIT						
NOTE: IF YOU ARE BIDDING AN "EQUAL", PLEASE SUBMIT SPECIFICATIONS AND A COLORED CATALOG OR BROCHURE WITH YOUR BID; IDENTIFYING THE BRAND AND MODEL NUMBER.						
0001	1	LS		165-05		\$ 110,770.00
CAFETERIA / KITCHEN EQUIPMENT						
EXHIBIT 5						
NOTICE TO PROCEED: THIS CONTRACT IS TO BE PERFORMED WITHIN 60 CALENDAR DAYS AFTER THE NOTICE TO PROCEED IS RECEIVED. UNLESS OTHERWISE SPECIFIED, THE FULLY EXECUTED PURCHASE ORDER WILL BE CONSIDERED NOTICE TO						

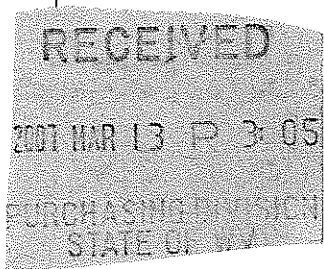

SIGNATURE <i>Mark K. Sullivan</i>			SEE REVERSE SIDE FOR TERMS AND CONDITIONS		TELEPHONE (304) 346-0521		DATE 03/13/07	
TITLE Vice President		FEIN 201961955-001		ADDRESS CHANGES TO BE NOTED ABOVE				

WHEN RESPONDING TO RFQ, INSERT NAME AND ADDRESS IN SPACE ABOVE LABELED 'VENDOR'



State of West Virginia  
 Department of Administration  
 Purchasing Division  
 2019 Washington Street East  
 Post Office Box 50130  
 Charleston, WV 25305-0130

# Request for Quotation

RFQ NUMBER
COR61336

PAGE
2

ADDRESS CORRESPONDENCE TO ATTENTION OF
JOHN ABBOTT 304-558-2544

VENDOR	*709035634      304-346-0521
	HOOTEN EQUIPMENT COMPANY LLC
	PO BOX 109
	CHARLESTON WV 25321

SHIP TO	DIVISION OF CORRECTIONS
	617 LEON SULLIVAN WAY
	CHARLESTON, WV 25301
	304-558-8045

DATE PRINTED	TERMS OF SALE	SHIP VIA	F.O.B.	FREIGHT TERMS
02/12/2007				
BID OPENING DATE: 03/08/2007		BID OPENING TIME 01:30PM		

LINE	QUANTITY	UOP	CAT NO.	ITEM NUMBER	UNIT PRICE	AMOUNT
<p>PROCEED.</p> <p>CANCELLATION: THE DIRECTOR OF PURCHASING RESERVES THE RIGHT TO CANCEL THIS CONTRACT IMMEDIATELY UPON WRITTEN NOTICE TO THE VENDOR IF THE MATERIALS OR WORKMANSHIP SUPPLIED ARE OF AN INFERIOR QUALITY OR DO NOT CONFORM WITH THE SPECIFICATIONS OF THE BID AND CONTRACT HERE IN.</p> <p>WAGE RATES: THE CONTRACTOR OR SUBCONTRACTOR SHALL PAY THE HIGHER OF THE U.S. DEPARTMENT OF LABOR MINIMUM WAGE RATES AS ESTABLISHED FOR FAYETTE COUNTY PURSUANT TO WEST VIRGINIA CODE 21-5A, ET, SEQ. (PREVAILING WAGE RATES APPLY TO THIS PROJECT)</p> <p>ARBITRATION: ANY REFERENCES MADE TO ARBITRATION OR INTEREST FOR PAYMENTS DUE (EXCEPT FOR ANY INTEREST REQUIRED BY STATE LAW) CONTAINED IN THIS CONTRACT OR IN ANY AMERICAN INSTITUTE OF ARCHITECTS DOCUMENTS PERTAINING TO THIS CONTRACT ARE HEREBY DELETED.</p> <p>WORKERS' COMPENSATION: VENDOR IS REQUIRED TO PROVIDE A CERTIFICATE FROM WORKERS' COMPENSATION IF SUCCESSFUL.</p> <p>ALL OF THE ITEMS CHECKED BELOW WILL BE A REQUIREMENT OF THIS CONTRACT:</p> <p>(XX) INSURANCE: SUCCESSFUL VENDOR SHALL FURNISH PROOF OF COMMERCIAL GENERAL LIABILITY INSURANCE PRIOR TO ISSUANCE OF CONTRACT. UNLESS OTHERWISE SPECIFIED IN THE BID DOCUMENTS, THE MINIMUM AMOUNT OF INSURANCE COVERAGE REQUIRED IS \$250,000.</p> <p>( ) BUILDERS RISK INSURANCE: SUCCESSFUL VENDOR SHALL FURNISH PROOF OF BUILDERS RISK - ALL RISK INSURANCE IN AN AMOUNT EQUAL TO 100% OF THE AMOUNT OF THE CONTRACT.</p>						

SEE REVERSE SIDE FOR TERMS AND CONDITIONS			
SIGNATURE	TELEPHONE	DATE	
TITLE	FEIN	ADDRESS CHANGES TO BE NOTED ABOVE	

WHEN RESPONDING TO RFQ, INSERT NAME AND ADDRESS IN SPACE ABOVE LABELED 'VENDOR'



State of West Virginia  
 Department of Administration  
 Purchasing Division  
 2019 Washington Street East  
 Post Office Box 50130  
 Charleston, WV 25305-0130

# Request for Quotation

RFQ NUMBER  
**COR61336**

PAGE  
**3**

ADDRESS CORRESPONDENCE TO ATTENTION OF:  
**JOHN ABBOTT**  
**304-558-2544**

VENDOR

\*709035634      304-346-0521  
 HOOTEN EQUIPMENT COMPANY LLC  
 PO BOX 109  
  
 CHARLESTON WV 25321

SHIP TO

DIVISION OF CORRECTIONS  
  
 617 LEON SULLIVAN WAY  
  
 CHARLESTON, WV  
 25301      304-558-8045

DATE PRINTED <b>02/12/2007</b>	TERMS OF SALE	SHIP VIA	F.O.B.	FREIGHT TERMS
BID OPENING DATE: <b>03/08/2007</b>		BID OPENING TIME <b>01:30PM</b>		

LINE	QUANTITY	UOP	CAT NO	ITEM NUMBER	UNIT PRICE	AMOUNT
<p>(XX) BONDS: FIVE PERCENT (5%) OF THE TOTAL AMOUNT OF THE BID PAYABLE TO THE STATE OF WEST VIRGINIA, SHALL BE SUBMITTED WITH EACH BID AS A BID BOND. THE SUCCESSFUL BIDDER SHALL ALSO FURNISH A PERFORMANCE BOND AND LABOR/MATERIAL BOND FOR 100% OF THE AMOUNT OF THE CONTRACT. BONDS MAY BE PROVIDED IN THE FORM OF A CERTIFIED CHECK, IRREVOCABLE LETTER OF CREDIT, OR BOND FURNISHED BY A SOLVENT SURETY COMPANY AUTHORIZED TO DO BUSINESS IN THE STATE OF WEST VIRGINIA. A LETTER OF CREDIT SUBMITTED IN LIEU OF A PERFORMANCE AND LABOR &amp; MATERIAL BOND WILL ONLY BE ALLOWED FOR PROJECTS UNDER \$100,000. PERSONAL OR BUSINESS CHECKS ARE NOT ACCEPTABLE IN LIEU OF THE 5% BID BOND, PERFORMANCE BOND, OR LABOR AND MATERIAL BOND.</p> <p>( ) MAINTENANCE BOND: A TWO (2) YEAR MAINTENANCE BOND COVERING THE ROOFING SYSTEM WILL BE A REQUIREMENT OF THE SUCCESSFUL VENDOR.</p> <p>REV. 11/00</p> <p>EXHIBIT 7</p> <p>DOMESTIC ALUMINUM, GLASS &amp; STEEL IN PUBLIC WORKS PROJECTS</p> <p>IN ACCORDANCE WITH WEST VIRGINIA CODE 5-19-1 ET., SEQ., EVERY CONTRACT FOR CONSTRUCTION, RECONSTRUCTION, ALTERATION, REPAIR, IMPROVEMENT OR MAINTENANCE OF PUBLIC WORKS, WHERE THE COST IS MORE THAN \$50,000 AND, IN THE CASE OF STEEL ONLY, WHERE THE COST OF STEEL IS MORE THAN \$50,000 OR WHERE MORE THAN 10,000 POUNDS OF STEEL ARE REQUIRED, THE STATE WILL ACCEPT ONLY ALUMINUM GLASS, OR STEEL PRODUCTS PRODUCED IN THE UNITED STATES</p>						

SEE REVERSE SIDE FOR TERMS AND CONDITIONS

SIGNATURE	TELEPHONE	DATE
TITLE	FEIN	ADDRESS CHANGES TO BE NOTED ABOVE

WHEN RESPONDING TO RFQ, INSERT NAME AND ADDRESS IN SPACE ABOVE LABELED 'VENDOR'



State of West Virginia  
 Department of Administration  
 Purchasing Division  
 2019 Washington Street East  
 Post Office Box 50130  
 Charleston, WV 25305-0130

# Request for Quotation

RFQ NUMBER
<b>CR61336</b>

PAGE
<b>4</b>

ADDRESS CORRESPONDENCE TO ATTENTION OF
<b>JOHN ABBOTT 304-558-2544</b>

VENDOR

\*709035634      304-346-0521  
 HOOTEN EQUIPMENT COMPANY LLC  
 PO BOX 109  
  
 CHARLESTON WV 25321

SHIP TO

DIVISION OF CORRECTIONS  
  
 617 LEON SULLIVAN WAY  
  
 CHARLESTON, WV  
 25301      304-558-8045

DATE PRINTED	TERMS OF SALE	SHIP VIA	F.O.B	FREIGHT TERMS
<b>02/12/2007</b>				
BID OPENING DATE: <b>03/08/2007</b>		BID OPENING TIME <b>01:30PM</b>		

LINE	QUANTITY	UOP	CAT NO.	ITEM NUMBER	UNIT PRICE	AMOUNT
<p>IN ADDITION, ITEMS OF MACHINERY OR EQUIPMENT PURCHASED FOR USE AT THE SITE OF PUBLIC WORKS SHALL BE MADE OF DOMESTIC ALUMINUM, GLASS OR STEEL, UNLESS THE COST OF THE PRODUCT IS LESS THAN \$50,000 OR LESS THAN 10,000 POUNDS OF STEEL ARE USED IN PUBLIC WORKS PROJECTS.</p> <p>FOREIGN MADE ALUMINUM, GLASS OR STEEL PRODUCTS MAY BE ACCEPTED ONLY IF THE COST OF DOMESTIC PRODUCTS IS FOUND TO BE UNREASONABLE. SUCH COST IS UNREASONABLE IF IT IS 20% OR MORE HIGHER THAN THE BID PRICE FOR FOREIGN MADE PRODUCTS. IF THE DOMESTIC ALUMINUM, GLASS OR STEEL PRODUCTS TO BE SUPPLIED OR PRODUCED IN A "SUBSTANTIAL LABOR SURPLUS AREA", AS DEFINED BY THE UNITED STATES DEPARTMENT OF LABOR, FOREIGN PRODUCTS MAY BE SUPPLIED ONLY IF DOMESTIC PRODUCTS ARE 30% OR MORE HIGHER IN PRICE THAN THE FOREIGN MADE PRODUCTS.</p> <p>IF, PRIOR TO THE AWARD OF A CONTRACT UNDER THE ABOVE PROVISIONS, THE SPENDING OFFICER OF THE SPENDING UNIT DETERMINES THAT THERE EXISTS A BID FOR LIKE FOREIGN ALUMINUM, GLASS OR STEEL THAT IS REASONABLE AND LOWER THAN THE LOWEST BID DOMESTIC PRODUCTS, THE SPENDING OFFICE MAY REQUEST, IN WRITING, A REEVALUATION AND REDUCTION IN THE LOWEST BID FOR SUCH DOMESTIC PRODUCTS ALL VENDORS MUST INDICATE IN THEIR BID IF THEY ARE SUPPLYING FOREIGN ALUMINUM, GLASS OR STEEL.</p> <p>REV. 3/88</p> <p>EXHIBIT 9</p> <p>NOTICE FOR ISSUANCE &amp; ACKNOWLEDGEMENT OF CONSTRUCTION PROJECT ADDENDA</p> <p>THE ARCHITECT/ENGINEER AND/OR AGENCY SHALL BE REQUIRED</p>						

SEE REVERSE SIDE FOR TERMS AND CONDITIONS

SIGNATURE	TELEPHONE	DATE
TITLE	FEIN	ADDRESS CHANGES TO BE NOTED ABOVE

WHEN RESPONDING TO RFQ, INSERT NAME AND ADDRESS IN SPACE ABOVE LABELED 'VENDOR'



State of West Virginia  
 Department of Administration  
 Purchasing Division  
 2019 Washington Street East  
 Post Office Box 50130  
 Charleston, WV 25305-0130

# Request for Quotation

RFQ NUMBER
<b>COR61336</b>

PAGE
<b>5</b>

ADDRESS CORRESPONDENCE TO ATTENTION OF:
<b>JOHN ABBOTT 304-558-2544</b>

VENDOR

\*709035634      304-346-0521  
**HOOTEN EQUIPMENT COMPANY LLC**  
**PO BOX 109**  
  
**CHARLESTON WV 25321**

SHIP TO

**DIVISION OF CORRECTIONS**  
  
**617 LEON SULLIVAN WAY**  
  
**CHARLESTON, WV**  
**25301                                      304-558-8045**

DATE PRINTED	TERMS OF SALE	SHIP VIA	F.O.B.	FREIGHT TERMS
<b>02/12/2007</b>				

BID OPENING DATE: **03/08/2007**                                      BID OPENING TIME **01:30PM**

LINE	QUANTITY	UOP	CAT NO	ITEM NUMBER	UNIT PRICE	AMOUNT
<p>TO ABIDE BY THE FOLLOWING SCHEDULE IN ISSUING CONSTRUCTION PROJECT ADDENDA FOR STATE AGENCIES:</p> <p>(1) THE ARCHITECT/ENGINEER SHALL PREPARE THE ADDENDUM AND A LIST OF ALL PARTIES THAT HAVE PROCURED DRAWINGS AND SPECIFICATIONS FOR THE PROJECT. THE ADDENDUM AND LIST SHALL BE FORWARDED TO THE BUYER IN THE STATE PURCHASING DIVISION. THE ARCHITECT/ENGINEER SHALL ALSO SEND A COPY OF THE ADDENDUM TO THE STATE AGENCY FOR WHICH THE CONTRACT IS ISSUED.</p> <p>(2) THE BUYER SHALL SEND THE ADDENDUM TO ALL INTERESTED PARTIES AND, IF NECESSARY, EXTEND THE BID OPENING DATE. ANY ADDENDUM SHOULD BE RECEIVED BY THE BUYER WITHIN FOURTEEN (14) DAYS PRIOR TO THE BID OPENING DATE.</p> <p>(3) ALL ADDENDA SHOULD BE FORMALLY ACKNOWLEDGED BY ALL BIDDERS AND SUBMITTED TO THE STATE PURCHASING DIVISION. THE SAME RULES AND REGULATIONS THAT APPLY TO THE ORIGINAL BIDDING DOCUMENT SHALL ALSO APPLY TO AN ADDENDUM DOCUMENT. THE ONLY EXCEPTION MAY BE FOR AN ADDENDUM THAT IS ISSUED FOR THE SOLE PURPOSE OF CHANGING A BID OPENING TIME AND/OR DATE.</p> <p>REV. 11/96</p> <p>EXHIBIT 10</p> <p>ADDENDUM ACKNOWLEDGEMENT</p> <p>I HEREBY ACKNOWLEDGE RECEIPT OF THE FOLLOWING CHECKED ADDENDUM(S) AND HAVE MADE THE NECESSARY REVISIONS TO MY PROPOSAL, PLANS AND/OR SPECIFICATION, ETC.</p>						

SEE REVERSE SIDE FOR TERMS AND CONDITIONS

SIGNATURE	TELEPHONE	DATE
TITLE	FEIN	ADDRESS CHANGES TO BE NOTED ABOVE

WHEN RESPONDING TO RFQ, INSERT NAME AND ADDRESS IN SPACE ABOVE LABELED 'VENDOR'



State of West Virginia  
 Department of Administration  
 Purchasing Division  
 2019 Washington Street East  
 Post Office Box 50130  
 Charleston, WV 25305-0130

# Request for Quotation

RFQ NUMBER  
**COR61336**

PAGE  
**6**

ADDRESS CORRESPONDENCE TO ATTENTION OF:  
**JOHN ABBOTT**  
**304-558-2544**

VENDOR

\*709035634      304-346-0521  
 HOOTEN EQUIPMENT COMPANY LLC  
 PO BOX 109  
  
 CHARLESTON WV 25321

SHIP TO

DIVISION OF CORRECTIONS  
 617 LEON SULLIVAN WAY  
 CHARLESTON, WV  
 25301      304-558-8045

DATE PRINTED <b>02/12/2007</b>	TERMS OF SALE	SHIP VIA	F.O.B.	FREIGHT TERMS
-----------------------------------	---------------	----------	--------	---------------

BID OPENING DATE: **03/08/2007**      BID OPENING TIME **01:30PM**

LINE	QUANTITY	UOP	CAT NO.	ITEM NUMBER	UNIT PRICE	AMOUNT
ADDENDUM NOS.:						
NO. 1			X			
NO. 2						
NO. 3						
NO. 4						
NO. 5						
I UNDERSTAND THAT FAILURE TO CONFIRM THE RECEIPT OF THE ADDENDUM(S) MAY BE CAUSE FOR REJECTION OF THE BIDS.						
<i>Mark Sullivan</i>				SIGNATURE		
HOOTEN EQUIPMENT COMPANY LLC				COMPANY		
03/13/07				DATE		
REV. 11/96						
CONTRACTORS LICENSE						
WEST VIRGINIA STATE CODE 21-11-2 REQUIRES THAT ALL PERSONS DESIRING TO PERFORM CONTRACTING WORK IN THIS STATE MUST BE LICENSED. THE WEST VIRGINIA CONTRACTORS LICENSING BOARD IS EMPOWERED TO ISSUE THE CONTRACTORS LICENSE. APPLICATIONS FOR A CONTRACTORS LICENSE MAY BE MADE BY CONTACTING THE WEST VIRGINIA DIVISION OF LABOR CAPITOL COMPLEX, BUILDING 3, ROOM 319, CHARLESTON, WV 25305. TELEPHONE: (304) 558-7890.						

SEE REVERSE SIDE FOR TERMS AND CONDITIONS

SIGNATURE	TELEPHONE	DATE
TITLE	FEIN	ADDRESS CHANGES TO BE NOTED ABOVE

WHEN RESPONDING TO RFQ, INSERT NAME AND ADDRESS IN SPACE ABOVE LABELED 'VENDOR'



State of West Virginia  
 Department of Administration  
 Purchasing Division  
 2019 Washington Street East  
 Post Office Box 50130  
 Charleston, WV 25305-0130

# Request for Quotation

RFQ NUMBER
<b>COR61336</b>

PAGE
<b>7</b>

ADDRESS CORRESPONDENCE TO ATTENTION OF
<b>JOHN ABBOTT</b> <b>304-558-2544</b>

VENDOR

\*709035634      304-346-0521  
 HOOTEN EQUIPMENT COMPANY LLC  
 PO BOX 109  
  
 CHARLESTON WV 25321

SHIP TO

DIVISION OF CORRECTIONS  
  
 617 LEON SULLIVAN WAY  
  
 CHARLESTON, WV  
 25301      304-558-8045

DATE PRINTED	TERMS OF SALE	SHIP VIA	F.O.B.	FREIGHT TERMS
<b>02/12/2007</b>				

BID OPENING DATE: **03/08/2007**      BID OPENING TIME **01:30PM**

LINE	QUANTITY	UOP	CAT NO.	ITEM NUMBER	UNIT PRICE	AMOUNT
<p>WEST VIRGINIA STATE CODE 21-11-11 REQUIRES ANY PROSPECTIVE BIDDER TO INCLUDE THE CONTRACTORS LICENSE NUMBER ON THEIR BID.</p> <p>BIDDER TO COMPLETE:</p> <p>CONTRACTORS NAME: ..... HOOTEN EQUIPMENT LLC .....</p> <p>CONTRACTORS LICENSE NO.: ..... WVO38448 .....</p> <p>THE SUCCESSFUL BIDDER WILL BE REQUIRED TO FURNISH A COPY OF THEIR CONTRACTORS LICENSE PRIOR TO ISSUANCE OF A PURCHASE ORDER/CONTRACT</p> <p style="text-align: center;">APPLICABLE LAW</p> <p>THE WEST VIRGINIA STATE CODE, PURCHASING DIVISION RULE AND REGULATIONS, AND THE INFORMATION PROVIDED IN THE "REQUEST FOR QUOTATION" ISSUED BY THE PURCHASING DIVISION IS THE SOLE AUTHORITY GOVERNING THIS PROCUREMENT.</p> <p>ANY INFORMATION PROVIDED IN SPECIFICATION MANUALS, OR ANY OTHER SOURCE, VERBAL OR WRITTEN, WHICH CONTRADICTS OR ALTERS THE INFORMATION PROVIDED FROM THE SOURCES AS DESCRIBED IN THE ABOVE PARAGRAPH IS VOID AND OF NO EFFECT.</p> <p>BANKRUPTCY: IN THE EVENT THE VENDOR/CONTRACTOR FILES FOR BANKRUPTCY PROTECTION, THIS CONTRACT IS AUTOMATICALLY NULL AND VOID, AND IS TERMINATED WITHOUT FURTHER ORDER.</p> <p>REV. 1/2005</p>						

SEE REVERSE SIDE FOR TERMS AND CONDITIONS

SIGNATURE	TELEPHONE	DATE
TITLE	FEIN	ADDRESS CHANGES TO BE NOTED ABOVE

WHEN RESPONDING TO RFQ, INSERT NAME AND ADDRESS IN SPACE ABOVE LABELED 'VENDOR'



State of West Virginia  
 Department of Administration  
 Purchasing Division  
 2019 Washington Street East  
 Post Office Box 50130  
 Charleston, WV 25305-0130

# Request for Quotation

RFQ NUMBER
<b>COR61336</b>

PAGE
<b>8</b>

ADDRESS CORRESPONDENCE TO ATTENTION OF:
<b>JOHN ABBOTT</b> <b>304-558-2544</b>

VENDOR

\*709035634      304-346-0521  
 HOOTEN EQUIPMENT COMPANY LLC  
 PO BOX 109  
  
 CHARLESTON WV 25321

SHIP TO

DIVISION OF CORRECTIONS  
  
 617 LEON SULLIVAN WAY  
  
 CHARLESTON, WV  
 25301      304-558-8045

DATE PRINTED	TERMS OF SALE	SHIP VIA	F.O.B.	FREIGHT TERMS
<b>02/12/2007</b>				

BID OPENING DATE: **03/08/2007**      BID OPENING TIME **01:30PM**

LINE	QUANTITY	UOP	CAT NO.	ITEM NUMBER	UNIT PRICE	AMOUNT
<b>NOTICE</b>						
A SIGNED BID MUST BE SUBMITTED TO:						
DEPARTMENT OF ADMINISTRATION PURCHASING DIVISION BUILDING 15 2019 WASHINGTON STREET, EAST CHARLESTON, WV 25305-0130						
THE BID SHOULD CONTAIN THIS INFORMATION ON THE FACE OF THE ENVELOPE OR THE BID MAY NOT BE CONSIDERED:						
SEALED BID						
BUYER:				JOHN ABBOTT-----		
REQ. NO.:				COR61336-----		
BID OPENING DATE:				<del>3/8/2007</del> -----03/14/2007-----		
BID OPENING TIME:				1:30 PM-----		
PLEASE PROVIDE A FAX NUMBER IN CASE IT IS NECESSARY TO CONTACT YOU REGARDING YOUR BID:						
(304)346-3421						
-----						
PLEASE PRINT OR TYPE NAME OF PERSON TO CONTACT CONCERNING THIS QUOTE:						
Mark K. Williams-----						

SEE REVERSE SIDE FOR TERMS AND CONDITIONS

SIGNATURE	TELEPHONE	DATE
TITLE	FEIN	ADDRESS CHANGES TO BE NOTED ABOVE

WHEN RESPONDING TO RFQ, INSERT NAME AND ADDRESS IN SPACE ABOVE LABELED 'VENDOR'





State of West Virginia  
 Department of Administration  
 Purchasing Division  
 2019 Washington Street East  
 Post Office Box 50130  
 Charleston, WV 25305-0130

# Request for Quotation

RFQ NUMBER
<b>COR61336</b>

PAGE
<b>9</b>

ADDRESS CORRESPONDENCE TO ATTENTION OF:
<b>JOHN ABBOTT</b> <b>304-558-2544</b>

VENDOR

\*709035634      304-346-0521  
 HOOTEN EQUIPMENT COMPANY LLC  
 PO BOX 109  
  
 CHARLESTON WV 25321

SHIP TO

DIVISION OF CORRECTIONS  
  
 617 LEON SULLIVAN WAY  
  
 CHARLESTON, WV  
 25301      304-558-8045

DATE PRINTED	TERMS OF SALE	SHIP VIA	F.O.B.	FREIGHT TERMS
<b>02/12/2007</b>				

BID OPENING DATE: **03/08/2007**      BID OPENING TIME **01:30PM**

LINE	QUANTITY	UOP	CAT NO	ITEM NUMBER	UNIT PRICE	AMOUNT
***** THIS IS THE END OF RFQ    COR61336 ***** TOTAL:						<u>110,770.00</u>

SEE REVERSE SIDE FOR TERMS AND CONDITIONS

SIGNATURE	TELEPHONE	DATE
TITLE	FEIN	ADDRESS CHANGES TO BE NOTED ABOVE

WHEN RESPONDING TO RFQ, INSERT NAME AND ADDRESS IN SPACE ABOVE LABELED 'VENDOR'

WV-36A (Rev. 01/01/07)

STATE OF WEST VIRGINIA  
**PURCHASE CONTINUATION SHEET**

Vendor: Hooten Equipment Company LLC

Buyer:	Page:	Requisition or P.O. No.:
		<b>COR61336</b>
Spending Unit:		
<b>Mt. Olive</b>		

Item	Quantity	Description	Cost
		(Alternative)	
1	1 each	<b>KETTLE, GAS</b> Vulcan-Hart Model GT100E Groen Model No. AH/1E-100, NAT,C or Equal Kettle, Natural gas 100 - gal, capacity, 2/3 jacket, 316 stainless steel liner, Stainless steel Insulated body, 2" TDO, 1/4" perforated strainer, #51 Counterbalanced actuator cover, faucet bracket, bullet feet, 115V controls, 30 PSI, 0-2000' elevation, 145,000 BTU	\$ 17,192.07
	1	One year limited parts & labor warranty, standard	
	1	040602 Faucet, double pantry, with spray hose, 48", for table top & floor model kettles.	
	1	107123 Brush Set, 3", includes kettle brush, drain valve brush, and paddle, for table top & floor model kettles.	
* NOTE: Vulcan Unit includes security package, flanged feet & connector hose.			
2	2 each	<b>BRAISING PAN, GAS (Alternative)</b> Vulcan-Hart Model VG30 Groen Model No. BPM-30G-NAT-E-TD or Equal Eclipse" Economic Braising Pan, Natural gas 30-gallon capacity, 10" deep pan with 2" tangent draw-off, 38" pan height, manual tilt, round tubular open leg base, stainless steel construction, with bullet feet, electronic spark ignition, 120v, 104,000 BTU (B)	
	2	One year limited parts & labor warranty, standard	
	1	146222 Faucet, couble pantry with swing spout & riser, left or right sided mounting	
	2	Prison Package	\$ 10,841.91
			\$ 21,683.82
*NOTE: Vulcan Unit includes security package, flanged feet & gas hose.			
3	1 each	<b>FRYER, GAS, MULTIPLE (Alternative)</b> Vulcan-Hart Model 3GR85DF Pitco Frialator Model No. 3-SG18D-S/ED or Equal Solstice Fryers, gas (3) 70-90 lb oil cap, full tanks, digital solid state w/countdown timers, drain valve interlock, melt cycle, matchless ignition, under-fryer drawer filtration, s/s tank, front & sides, total 420,000 BTU (-FFF)	
	1	Gas type to be determined	
	1	115v/80/1, 0.5 amps for controls per fryer	
	1	BNB-SS Bread & Batter Cabinet, fryer match design, standard finish, s/s exterior (free standing)	
	1	PFW-1 Built in food warmer, 750 watts	
	1	B3901504 Casters, 9", (set)	
	1 pack	PP10613 Filter Paper, envelope, heavy duty, 18-1/2" x 20-1/2", (for UFM14/UFM18, FD8G)	
	1	A3301001 Clean Out Rod, for cleaning fryer drain line	
	1	P6071397 Fryer Cleaner - 25 lb.	
	1	PP100656 Fryer Cleaning Brush, high temperature, Teflon	

WV-36A (Rev. 01/01/07)

STATE OF WEST VIRGINIA  
**PURCHASE CONTINUATION SHEET**

Vendor: Hooten Equipment Company LLC

Buyer:	Page:	Requisition or P.O. No.:
		<b>COR61336</b>
Spending Unit:		
<b>Mt. Olive</b>		

1		B7490701 Crumb Scoop, designed to fit between gas fryer tubes for Removal of heavy sediment	
1		PP10725 Skimmer-used for removing food particles from surface oil	
1		B5006901 Crumb Catcher, for use with Solstice Filter Drawer Only	
1		Dormont Manufacturing 15100KIT36 Safety Moveable gas connector Kit, 1" inside dia., 36" long, covered with stainless steel braid, Coated with blue antimicrobial PVC, 1 SnapFast QD, 1 full port valve, (2) 90: elbows, coiled restraining cable with hardware, limited lifetime warranty	
			\$ 16,910.36
4	2 each	GRIDDLE COUNTER UNIT, GAS Southbend Model No. HDG-72 or Equal Griddle, Gas, Counter Model, 72" wide, 1" thick polished steel plate, (4) Thermostatic controls range 150-400 F settings, s/s front & sides, 4" s/s Legs, 180000 BTU	
2		Natural Gas	
2		Standard one year limited warranty	
2		Electronic Ignition	
2		HDCS-72 Heavy Duty Counterline Stand, 72" wide, under shelf & open tubular legs	
2		Casters (factory installed ONLY)	
2		Dormont Manufacturing 1675KIT36 Safety System Moveable Gas Connector kit, 3/4" inside dia., 36" long, covered with stainless steel braid, coated with blue antimicrobial PVC, 1 SnapFast QD, 1 full port valve, (2) 90 degree elbows, coiled restraining cable with hardware, limited life time warranty	
			\$ 6,065.55      \$ 12,131.10
5	1 each	RANGE, GAS, HEAVY DUTY, 36" Southbend Model No. P36D-XX or Equal Platinum Heavy Duty Range, Gas, 36", (4) 45,000 BTU Open Burners. manual controls, 1-1/4" front manifold, standard oven base, stainless steel front and sides, 6" adj. Legs, 225,000 BTU	
1		Natural Gas	
1		1167782 1" gas pressure regulator (shipped loose) Nat gas-preset @ 6" -max cao, 600,000 BTU	
1		4450007 1" gas shut off valve	
1		Standard two year limited warranty (range)	
1		PRS24-36 Platinum Backguard/Flue Riser, with Single High Shelf, 24" High, 36" wide, stainless steel front and sides	
1		Casters, 2 locking & 2 standard, in lieu of legs	
1		Dormont Manufacturing 16100KIT36 Safety System Moveable Gas Connector Kit, 1" inside dia., covered with stainless steel braid Coated with blue antimicrobial PVC, 1 SnapFast QD, 1 full port valve, (2) 90 degree elbows, coiled restraining cable with hardware, limited life time warranty	
			\$ 4,776.42

WV-36A (Rev. 01/01/07)

STATE OF WEST VIRGINIA  
**PURCHASE CONTINUATION SHEET**

Vendor: Hooten Equipment Company LLC

Buyer:	Page:	Requisition or P.O. No.: <b>COR61336</b>
Spending Unit: <b>Mt. Olive</b>		

- (Alternative) Scotsman CME1056/BH801S
- 6      1 each      **ICE MAKER, CUBE-STYLE**  
 Manitowoc Model No. SY-1004A or Equal  
 S-Series Ice Maker, cube-style, air-cooled, self-contained condenser, up to 1060-lb approximately/24 hours, stainless steel finish, half dice size cubes
  - 1      3-year parts and labor warranty
  - 1      5-year parts and labor warranty on evaporator
  - 1      5-year parts and 3-year labor warranty on compressor
  - 1      308-230v/60/1ph, std.
  - 1      Ice bin, w/top-hinged front-opening door, approx. 710 lb ice storage capacity, for top-mounted ice maker, stainless steel exterior
  - 1      3-year parts and labor warranty
  - 1      Bin Adapter, 30" Manitowoc Ice Machine to 48" B-970 bin, no weight limit
  - 1      Artic Pure, Primary Water Filter Assembly, includes head, shroud, hardware, mounting assembly, and one filter cartridge

NOTE: Scotsman Unit includes tamper proof screw kit. \$ 3,990.80

- 7      1 each      **PEELER, VEGETABLE, ELECTRIC (Alternative) Blakeslee XC-60-T**  
 Hobart Model No. 6460c+BULDUP or Equal  
 Vegetable Peeler, Correctional, 50-60 lb. Potatoes in 1-3 minute cap., V-belt drive, removable, abrasive silicon carbide disc and lexan liner, welded s/s construction, lockable controls, tamper resistant fasteners, 1 hp.
- 1      1-Year parts, labor & travel time during normal working hours w/in theUSA.
- 1      6460C-ELE00E 200-230/60/3 -No Timer-
- 1      6460C-CTRUSA Usa/export
- 1      6460C-SWITUM Switch non-timed
- 1      6460C-SWPORH Switch on rh side
- 1      6460C-CBTSST Cabinet, base and trap - s/s strainer

\$ 3,331.81

- 8      1 each      **MIXER, FOOD**  
 Hobart Model No. HL600-1STD or Equal  
 Legacy Planetary Mixer, 2.7 HP, 80 qt., four fixed speeds, gear trans, 50 min. timer, no. 12 attach hub, power bowl lift, s/s bowl, "B" beater, "D" wire whip, "ED" dough hook, 200-240/50/60/3/1
- 1      1-year parts, labor and travel time during normal working hour w/in the USA

\$ 12,868.02

- 9      1 each      **MEAT GRINDER**  
 Hobart Model No. 4732 + BULDUP or Equal  
 Chopper -4732, BASE UNIT ONLY, 3-HP motor, No. 32 hub
- 1      4732-ELE00F 200/60/3
- 1      4732-CTRUSA - usa/export

WV-36A (Rev. 01/01/07)

STATE OF WEST VIRGINIA  
**PURCHASE CONTINUATION SHEET**

Vendor: Hooten Equipment Company LLC

Buyer:	Page:	Requisition or P.O. No.:
		<b>COR61336</b>
Spending Unit:		
<b>Mt. Olive</b>		

1	4732-PANSST No. 32 stainless steel feed pan		
1	4732-SWIMNO Switch without thermal overload		
1	4732-FINPTD Epoxy enamel finish		
1	4732-ENDTIN No. 32 tinned chopping end		
1	32 LEG-5-3/8" leg set		\$ 4,291.34

10	2	<b>SLICER, FOOD(Alternative) Globe Model 4975</b> Hobart Model No. 2912-1 or Equal Slicer, semi-auto, angle fd, 12" s/s Clean Cut Knife, MICROBAN Entimicrobial product prot'n. ga. plate interlock, Poly-V-Belt, perm., ring grd, 6-speed auto, s/s knife cvr. Top mounted sharpener, low fence, s/s carriage w/tilt, 120/60/1, 1/2 hp		
	2	1-Year parts, labor and travel time during normal working hours		
	2	FOOD-CHUTE / Food chute	\$ 4,903.82	\$ 9,807.64

NOTE: Globe unit includes prison package

11	1 each	<b>REFRIG...ROLL-IN (Alternative) Victory Model RIS-1D-S7</b> Traulsen Model No. RR1132HUI-FHS or Equal Refrigerator, Roll-In, One Section, Self-Contained Refrig System, stainless steel exterior and interior, standard depth cabinet, full-height doors, accepts 72" high racks, with INTELA-TRAUL		
	1	115v/60/1 ph, w/cord and plug attached, std.		
	1	1-Year service/labor and 5 year compressor warranty, standard		
	1	Door hinged on right, standard		

NOTE: Victory Unit includes security package. \$ 3,786.62

GRAND TOTAL: \$ 110,770.00

# AFFIDAVIT

**West Virginia Code §5A-3-10a states:**

No contract or renewal of any contract may be awarded by the state or any of its political subdivisions to any vendor or prospective vendor when the vendor or prospective vendor or a related party to the vendor or prospective vendor is a debtor and the debt owned is an amount greater than one thousand dollars in the aggregate

**DEFINITIONS:**

"Debt" means any assessment, premium, penalty, fine, tax or other amount of money owed to the state or any of its political subdivisions because of a judgment, fine, permit violation, license assessment, defaulted workers' compensation premium, penalty or other assessment presently delinquent or due and required to be paid to the state or any of its political subdivisions, including any interest or additional penalties accrued thereon.

"Debtor" means any individual, corporation, partnership, association, limited liability company or any other form or business association owing a debt to the state or any of its political subdivisions. "Political subdivision" means any county commission; municipality; county board of education; any instrumentality established by a county or municipality; any separate corporation or instrumentality established by one or more counties or municipalities, as permitted by law; or any public body charged by law with the performance of a government function or whose jurisdiction is coextensive with one or more counties or municipalities. "Related party" means a party, whether an individual, corporation, partnership, association, limited liability company or any other form or business association or other entity whatsoever, related to any vendor by blood, marriage, ownership or contract through which the party has a relationship of ownership or other interest with the vendor so that the party will actually or by effect receive or control a portion of the benefit, profit or other consideration from performance of a vendor contract with the party receiving an amount that meets or exceed five percent of the total contract amount.

**EXCEPTION:**

The prohibition of this section does not apply where a vendor has contested any tax administered pursuant to chapter eleven of this code, workers' compensation premium, permit fee or environmental fee or assessment and the matter has not become final or where the vendor has entered into a payment plan or agreement and the vendor is not in default of any of the provisions of such plan or agreement.

**LICENSING:**

Vendors must be licensed and in good standing in accordance with any and all state and local laws and requirements by any state or local agency of West Virginia, including, but not limited to, the West Virginia Secretary of State's Office, the West Virginia Tax Department, West Virginia Insurance Commission, or any other state agencies or political subdivision. Furthermore, the vendor must provide all necessary releases to obtain information to enable the Director or spending unit to verify that the vendor is licensed and in good standing with the above entities.

**CONFIDENTIALITY:**

The vendor agrees that he or she will not disclose to anyone, directly or indirectly, any such personally identifiable information or other confidential information gained from the agency, unless the individual who is the subject of the information consents to the disclosure in writing or the disclosure is made pursuant to the agency's policies, procedures and rules. Vendors should visit [www.state.wv.us/admin/purchase/privacy](http://www.state.wv.us/admin/purchase/privacy) for the Notice of Agency Confidentiality Policies.

Under penalty of law for false swearing (West Virginia Code, §61-5-3), it is hereby certified that the vendor acknowledges the information in this said affidavit and are in compliance with the requirements as stated.

Vendor's Name: HOOTEN EQUIPMENT COMPANY LLC

Authorized Signature:  Date: 03/14/2007

# STATE OF WEST VIRGINIA VENDOR PREFERENCE CERTIFICATE

Certification and application\* is hereby made for Preference in accordance with West Virginia Code, §5A-3-37. (Does not apply to construction contracts).

*West Virginia Code*, §5A-3-37, provides an opportunity for qualifying vendors to request (at the time of bid) preference for their residency status. Such preference is an evaluation method only and will be applied only to the cost bid in accordance with the *West Virginia Code*. This certificate for application is to be used to request such preference. The Purchasing Division will make the determination of the Resident Vendor Preference, if applicable.

**A. Application is made for 2.5% preference for the reason checked:**

Bidder is an individual resident vendor and has resided continuously in West Virginia for four (4) years immediately preceding the date of this certification;

or

Bidder is a partnership, association or corporation resident vendor and has maintained its headquarters or principal place of business continuously in West Virginia for four (4) years immediately preceding the date of this certification; or 80% of the ownership interest of Bidder is held by another individual, partnership, association or corporation resident vendor who has maintained its headquarters or principal place of business continuously in West Virginia for four (4) years immediately preceding the date of this certification;

or

Bidder is a nonresident vendor which has an affiliate or subsidiary which employs a minimum of one hundred state residents and which has maintained its headquarters or principal place of business within West Virginia continuously for the four (4) years immediately preceding the date of this certification.

**B. Application is made for 2.5% preference for the reason checked:**

Bidder is a resident vendor who certifies that, during the life of the contract, on average at least 75% of the employees working on the project being bid are residents of West Virginia who have resided in the state continuously for the two years immediately preceding submission of this bid;

or

Bidder is a nonresident vendor employing a minimum of one hundred state residents or is a nonresident vendor with an affiliate or subsidiary which maintains its headquarters or principal place of business within West Virginia employing a minimum of one hundred state residents who certifies that, during the life of the contract, on average at least 75% of the employees or Bidder's affiliate's or subsidiary's employees are residents of West Virginia who have resided in the state continuously for the two years immediately preceding submission of this bid.

Bidder understands if the Secretary of Tax & Revenue determines that a Bidder receiving preference has failed to continue to meet the requirements for such preference, the Secretary may order the Director of Purchasing to: (a) rescind the contract or purchase order issued; or (b) assess a penalty against such Bidder in an amount not to exceed 5% of the bid amount and that such penalty will be paid to the contracting agency or deducted from any unpaid balance on the contract or purchase order.

By submission of this certificate, Bidder agrees to disclose any reasonably requested information to the Purchasing Division and authorizes the Department of Tax & Revenue to disclose to the Director of Purchasing appropriate information verifying that Bidder has paid the required business taxes, provided that such information does not contain the amounts of taxes paid nor any other information deemed by the Tax Commissioner to be confidential.

Under penalty of law for false swearing (West Virginia Code, §61-5-3), Bidder hereby certifies that this certificate is true and accurate in all respects; and that if a contract is issued to Bidder and if anything contained within this certificate changes during the term of the contract, Bidder will notify the Purchasing Division in writing immediately.

Bidder: Hooten Equipment Company LLC

Signed: 

Date: 03/13/2007

Title: Vice President

\*Check any combination of preference consideration(s) in either "A" or "B", or both "A" and "B" which you are entitled to receive. You may request up to the maximum of 5% preference for both "A" and "B"

*(Alternate)*  
Item #

# VULCAN

## GS, GL, GT SERIES GAS FULLY JACKETED KETTLE

C.S.I. Section 11420

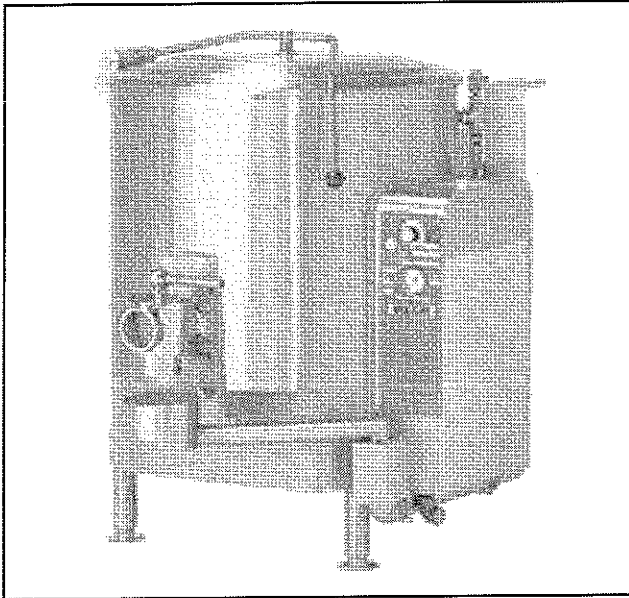

GL40	40 gallons	151 liters
GS60	60 gallons	227 liters
GL80	80 gallons	303 liters
<u>GT100</u>	100 gallons	379 liters
GT125	125 gallons	473 liters
GT150	150 gallons	568 liters

**SPECIFICATIONS:**

Gas fully jacketed stationary kettle, Vulcan Model No. \_\_\_\_\_  
Kettle is mounted on 2" diameter legs with adjustable flanged feet. Cover to be stainless steel dome shaped with drop type handle and insulated knob. The dish shaped interior bottom is sloped to the front for a smooth product flow through a mounted, tapered, 2" plug type food product draw-off valve. Draw-off includes opening strainer. Graduated measuring rod. Furnished standard with a 15 PSI relief valve, vacuum relief valve, thermostat with a combination gas control valve and electronic ignition, low water cut-off control and a pressure limit switch and pressure gauge.

CSA design certified. Classified by U L to NSF Std #4. Meets ASME code.

**STANDARD FEATURES**

- Kettle fully steam jacketed.
- Mounted on stainless steel 2" diameter legs with adjustable flange feet.
- Stainless steel dome shaped spring assist cover with drop type handle.
- Kettle interior bottom sloped to front for smooth product flow through a mounted, tapered, plug type food product draw-off valve of standard 2" diameter.
- Draw-off opening strainer.
- Graduated measuring rod.
- 15 PSI relief valve.
- Vacuum pressure relief valve.
- Thermostat with a combination gas control valve and electronic ignition.
- Low water cut-off control
- Pressure limit switch and pressure gauge.
- Faucet bracket.
- One year limited parts and labor warranty.

**OPTIONS**

- 3" tapered, plug type draw-off valve in place of 2".
- Change in leg height to increase clearance under draw-off valve.
- Condensate ring on cover hinges.
- Swing drain collector.
- 316 stainless steel jacket liner
- Second year extended limited parts and labor warranty.

**ACCESSORIES**

- Stainless steel draw-off extension tube.
- (12") (18" double jointed) single pantry faucet
- (12") (18" double jointed) double pantry faucet.
- Double pantry washdown hose with 16" add-on faucet with backflow preventer.
- Double pantry washdown hose with backflow preventer.
- Double pantry pot filler and backflow preventer.
- Rotating tri-basket assembly.
- Clean-up kit to include draw-off brush, clean-up brush with 36" handle and paddle scraper with 40" handle.
- 48" stainless steel whip.

VULCAN MODELS: GS, GL, GT SERIES Gas Fully Jacketed Kettle





**GS, GL, GT SERIES**  
GAS FULLY JACKETED KETTLES

**IMPORTANT:**

- 1 A pressure regulator sized for this unit is included. Natural gas 8.0" W.C Propane 10.5" W.C
- 2 Gas line connecting to unit must be 3/4" or larger. If flexible connectors are used the inside diameter must be at least the same as the 3/4" iron pipe and rated for the correct gas input
- 3 Requires 120 volt, 60 Hz, 1 phase electrical connection. Furnished with 6' cord and 3 prong plug. 3 amp total draw.
- 4 An adequate ventilation system is required for commercial cooking equipment. Information may be obtained by writing to the National Fire Protection Association, Batterymarch Park, Quincy, MA 02269. When writing refer to NFPA No 96
- 5 These units are manufactured for installation in accordance with ANSZ223.1a (latest edition), National Fuel Gas Code. Copies may be obtained from the American Gas Association, 1515 Wilson Blvd, Arlington, VA 22209.
- 6 Equipment Clearance:
 

	Combustible	Non-Combustible
Rear	2"	0"
Right	0"	0"
Left	0"	0"

**SERVICE CONNECTIONS:**

- Gas Supply:** 3/4" NPT, 6" AFF, Volume per schedule
- Electric Connection:** 120-1 Circuit 0.3 KW, 16 AFF
- Water:** Faucet location.

**NOTE:**

- Dimensions which locate the above connections have a tolerance of + or -3" (+ or -75 mm).
- Installation of backflow preventers, vacuum breakers and other specific code requirements is the responsibility of the owner and installer. It is the responsibility of the owner and installer to comply with local codes.
- Plastic drains are not recommended due to inherent limited temperatures of the plastic.
- This appliance is manufactured for commercial installation only and is not intended for home use.

**BRIMFUL CAPACITIES:**

Model	Gallons	Quarts	Liters	4 oz. svgs.
GL40	40	160	152	1280
GS60	60	240	227	1920
GL80	80	320	303	2560
<b>GT100</b>	100	400	379	3200
GT125	125	500	473	4000
GT150	150	600	568	4800

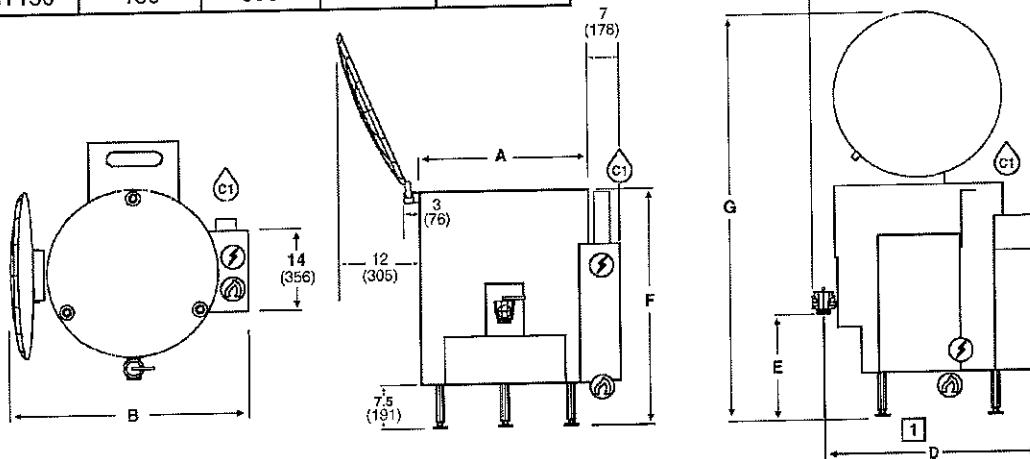

MODEL	CAPACITY	A	B	C	D	E	F	G	BTU/hr. INPUT
GL40	40 gal., 151 liters	29 (737)	48 (1219)	41 (1041)	38 (965)	14 (356)	40 (1016)	71 (1803)	105,000
GS60	60 gal., 227 liters	36 1/2 (927)	58 1/2 (1486)	48 (1219)	44 (1118)	17 (432)	39 (991)	78 (1981)	135,000
GL80	80 gal., 303 liters	36 1/2 (927)	58 1/2 (1486)	48 (1219)	44 (1118)	17 (432)	44 (1118)	83 (2108)	135,000
<b>GT100</b>	100 gal., 379 liters	36 1/2 (927)	58 1/2 (1486)	48 (1219)	44 (1118)	17 (432)	49 (1245)	88 (2235)	135,000
GT125	125 gal., 473 liters	36 1/2 (927)	58 1/2 (1486)	48 (1219)	44 (1118)	17 (432)	56 (1422)	95 (2413)	135,000
GT150	150 gal., 568 liters	36 1/2 (927)	58 1/2 (1486)	48 (1219)	44 (1118)	17 (432)	62 1/2 (1587)	101 (2565)	135,000

**NOTE:** In line with its policy to continually improve its products, Vulcan-Hart Company reserves the right to change materials and specifications without notice.



# Gas Connectors Specifier Sheet

## Deluxe Installation Kits & Hose Assemblies with SnapFast™ QD

### Product Part Numbers - Order Using Part Numbers Listed Below

Configuration	Inside Dia.	LENGTH				
		24"	36"	48"	60"	72"
DELUXE KIT *		1650KIT24	1650KIT36	1650KIT48	1650KIT60	1650KIT72
BASIC KIT **	1/2"	1650BPQR24	1650BPQR36	1650BPQR48	1650BPQR60	1650BPQR72
HOSE ASSEMBLY		1650BPQ24	1650BPQ36	1650BPQ48	1650BPQ60	1650BPQ72
DELUXE KIT *		1675KIT24	1675KIT36	1675KIT48	1675KIT60	1675KIT72
BASIC KIT **	3/4"	1675BPQR24	1675BPQR36	1675BPQR48	1675BPQR60	1675BPQR72
HOSE ASSEMBLY		1675BPQ24	1675BPQ36	1675BPQ48	1675BPQ60	1675BPQ72
DELUXE KIT *		16100KIT24	16100KIT36	16100KIT48	16100KIT60	16100KIT72
BASIC KIT **	1"	16100BPQR24	16100BPQR36	16100BPQR48	16100BPQR60	16100BPQR72
HOSE ASSEMBLY		16100BPQ24	16100BPQ36	16100BPQ48	16100BPQ60	16100BPQ72
DELUXE KIT *		16125KIT24	16125KIT36	16125KIT48	16125KIT60	16125KIT72
BASIC KIT **	1-1/4"	16125BPQR24	16125BPQR36	16125BPQR48	16125BPQR60	16125BPQR72
HOSE ASSEMBLY		16125BPQ24	16125BPQ36	16125BPQ48	16125BPQ60	16125BPQ72

### BTU Flow Capacity (Flow rating BTU 0.64 SP. GR. @ 0.5 inch WC pressure drop)

Part #	Inside Dia.	LENGTH					
		12"	24"	36"	48"	60"	72"
1650BPQ	1/2"	98,000	87,000	77,000	68,000	60,000	55,000
1675BPQ	3/4"	260,000	232,000	218,000	180,000	158,000	139,000
16100BPQ	1"	425,000	414,000	379,000	334,000	294,000	279,000
16125BPQ	1-1/4"	783,000	699,000	615,000	541,000	476,000	419,000

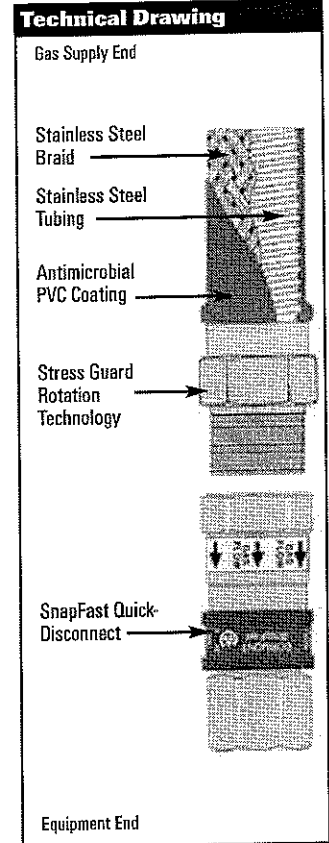

### Approvals & Certifications

- NSF** Component<sup>®</sup> NSF International Criteria C-2 Special Equipment and/or Devices
- SP** ANSI Z21 69 / CSA 6 16 - Connectors for Moveable Gas Appliances
- US** ANSI Z21 41 / CSA 6.9 - Quick-Disconnect Devices For Use With Gas Fuel
- Meets requirements of ANSI Z223.1 / NFPA 54 - National Fuel Gas Code
- Refer to catalog page 23 for additional approvals & certifications and Dormont gas connector limited lifetime warranty
- SnapFast is not for use in temperatures less than 32°F



### Features & Specifications

#### THE DORMONT BLUE HOSE:

- Tubing: Annealed 304 stainless steel (ASTM A240)
- Braiding: Multi-strand, 304 stainless steel wire
- Coating: Antimicrobial (patent #6,742,815) PVC, melts at 350°F, coating will not hold a flame; blue color indicates braided connector
- End Fittings: Carbon steel; zinc and yellow dichromate coating
- Stress Guard: 360° rotation of end fittings at both ends before and after installation (patent pending)

#### THE SNAPFAST ONE-HANDED QUICK-DISCONNECT - QD:

- Quick-Disconnect: Brass body carbon steel threaded end fittings, and aluminum collar
- Thermal Shut-off: Polymer insert in QD melts when internal temperatures exceed 350° F, to shut off gas flow

#### \* DELUXE KITS INCLUDE:

- Elbow: Malleable iron - 2 included
- Restraining Cable: PVC coated, carbon steel, multi-strand cable
- Valve: 100% full port, brass gas ball valve

\*\* BASIC KITS INCLUDE: The Dormont Blue Hose and restraining cable and hardware required for caster-mounted installations

DEMAND THE DIFFERENCE!

1-800-DORMONT  
**DORMONT**  
www.dormont.com

(Alternate)

Item # 2

C.S.I. Section 11420

# VULCAN

## VG SERIES MODULAR GAS TILTING BRAISING PAN

VULCAN MODELS: VG SERIES Modular Gas Tilting Braising Pan

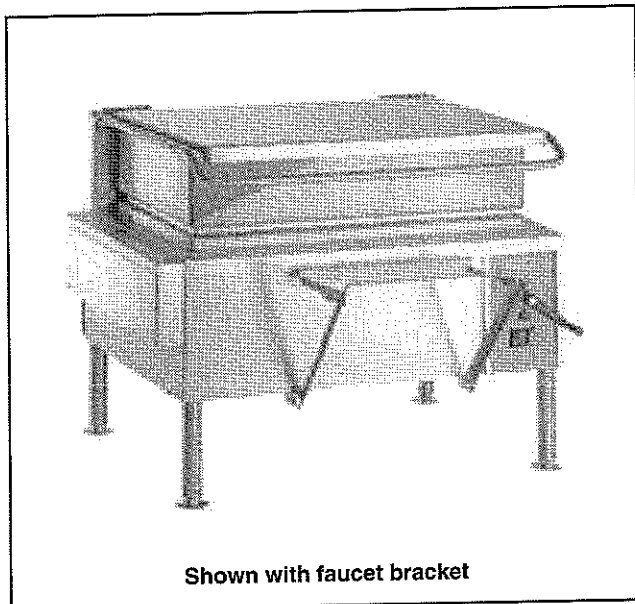

Shown with faucet bracket

- VG30 36" wide open base.
- VG40 46" wide open base.

### STANDARD FEATURES

- Stainless steel front, sides and 12" legs with adjustable flanged feet.
- Stainless steel back
- Front hinged polished stainless steel pan body with covered interior corners and embossed gallon markings. Stainless steel cooking surface bonded to steel plate. Full width 4" return flange with formed pouring lip and removable strainer.
- Stainless steel spring assist cover with full width handle.
- Drop away food receiving pan support mounts under pouring lip. (Not available with optional draw-off valve on VG30.)
- Manually operated pan tilting mechanism with folding swing away handle. Pan can be fully tilted to empty completely with approximately 30 crank revolutions.
- One 30,000 BTU/hr. burner for each 12" pan width. Burners shut off when pan is tilted 5°. Electronic ignition system for automatic burner lighting.
- Solid state temperature controls.
- Water tight controls and enclosures.
- Requires a 120/60/1 electrical power supply, 3.0 amps.
- 3/4" rear gas connection with gas pressure regulator.
- One year limited parts and labor warranty.

### OPTIONS

- Motor driven pan lift.
- 2" 90° draw-off valve with strainer on front left hand side. (Pan support will be removed on VG30.)
- 2" straight draw-off valve with strainer on left hand side. (Pan support will be removed on VG30.)
- Closed base.
- Standard prison package includes:
  - Security screws and tackwelds.
    - Includes securing crank handle, pan strainer and non-door type panels.
  - Controls protected by lockable cover.
  - Perforated flue cover.
- Second year extended limited parts and labor warranty.

### ACCESSORIES

- Set of four casters, (two locking).
- Faucet bracket assembly (adds 3" to width).
- (12") (18") double jointed single pantry faucet.
- (12") (18") double jointed double pantry faucet.
- Double pantry washdown hose with 16" add-on faucet with backflow preventer.
- Double pantry washdown hose with backflow preventer
- Double pantry pot filler and backflow preventer.
- Steaming pan insert rack to hold 12" x 20" pan. (Qty. \_\_\_)
- 12" x 20" x 4" stainless steel drain waste pan with clear plastic hose.
- Stainless steel spreader (6")(12").



### SPECIFICATIONS:

Modular gas tilting braising pan, Vulcan-Hart Model No. (VG30) (VG40). \_\_\_" wide open base. Stainless steel front, sides and 12" legs with adjustable flanged feet. Stainless steel back. Front hinged polished stainless steel pan body with covered interior corners and embossed gallon markings. Stainless steel cooking surface bonded to steel plate. Full width 4" return flange with formed pouring lip and removable strainer. Stainless steel spring assist cover with full width handle. Drop away food pan receiving support mounts under pouring lip. Manually operated pan tilting mechanism with folding swing away handle. Pan can be fully tilted to empty completely with approximately 30 crank revolutions. One 30,000 BTU/hr. burner for each 12" pan width. Burners shut off when pan is tilted 5°. Electronic ignition system for automatic burner light. Solid state temperature controls. Water tight controls and enclosures. Requires a 120/60/1 electrical power supply, 3.0 amps total draw. 3/4" rear gas connection and gas pressure regulator.

Exterior dimensions: \_\_\_"w x 35 1/2"d x 40 1/2"h on 12" legs.

CSA design certified. Classified by U L to NSF Std. #4.

**SPECIFY TYPE OF GAS WHEN ORDERING.**

**SPECIFY ALTITUDE WHEN ABOVE 2,000 FT.**

VULCAN-HART COMPANY, P.O. BOX 696, LOUISVILLE, KY 40201, TEL. 1-800-814-2028



# VG SERIES

## MODULAR GAS TILTING BRAISING PAN

**SERVICE CONNECTIONS:**

 **GAS INPUT:** 3/4" N.P.T., Nat. 6"-14" W.C., Propane. 11"-18" W.C See capacity schedule.

 **ELECTRICAL CONNECTION:** Control circuit 7/8" dia 120 volt, 1 phase, 15 amps, power cord

MODEL	Cooking Surface Area	Capacity	4 oz. Portions
<b>VG30</b>	29" x 23"	30 gal./114 liters	960
<b>VG40</b>	39" x 23"	40 gal./152 liters	1280

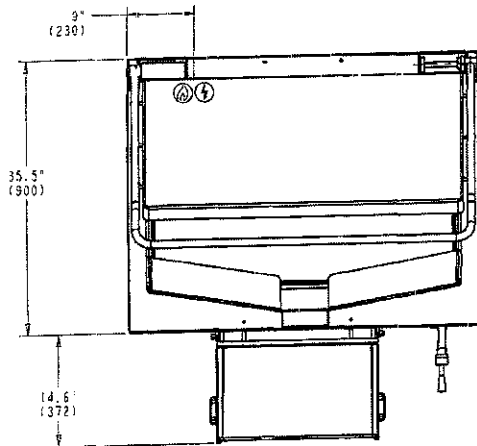

**IMPORTANT**

- 1 A pressure regulator sized for this unit is included. Natural gas 7" W.C., propane gas 11" W.C supply pressure
- 2 Gas line connecting to appliance must be 3/4" or larger. If flexible connectors are used, the inside diameter must be at least the same as the 3/4" iron pipe
- 3 An adequate ventilation system is required for commercial cooking equipment. Information may be obtained by writing to the National Fire Protection Association, Batterymarch Park, Quincy, MA 02289. When writing, refer to NFPA No. 96.
- 4 These units are manufactured for installation in accordance with ANSZ223 1A (Latest edition), National Fuel Gas Code. Copies may be obtained from the American Gas Association, 1515 Wilson Blvd., Arlington, VA 22209
5. Clearances:
 

	Combustible	Non-combustible
Rear	6	0
Sides	2	0
- 6 This appliance is manufactured for commercial installation only and is not intended for home use

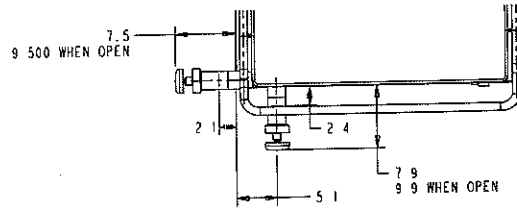

MODEL	BTU/hr. Input
<b>VG30</b>	90,000
<b>VG40</b>	120,000

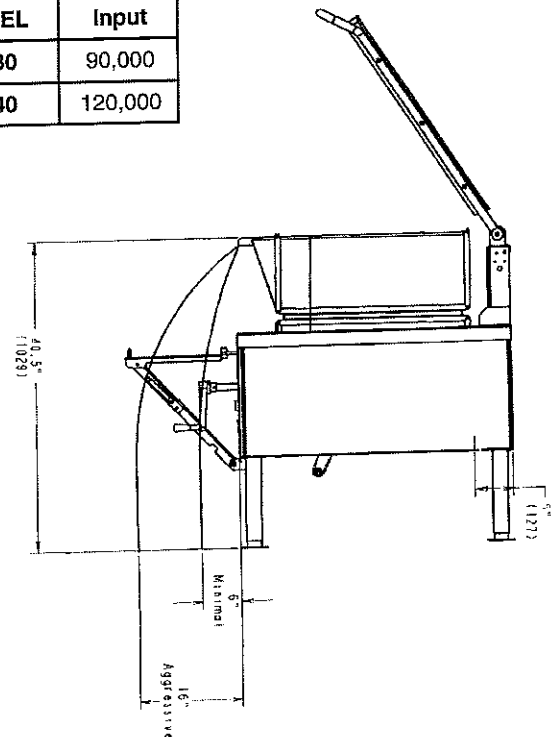
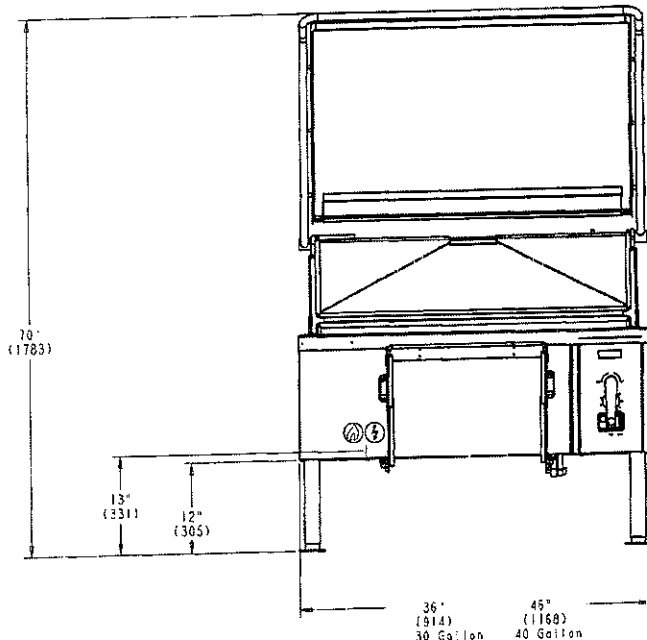

**NOTE:** In line with its policy to continually improve its products, Vulcan-Hart Company reserves the right to change materials and specifications without notice.

VULCAN-HART COMPANY, P.O. BOX 696, LOUISVILLE, KY 40201, TEL. 1-800-814-2028  
 502-778-2791 QUOTE & ORDER FAX: 1-800-444-0602



# Gas Connectors Specifier Sheet

## Deluxe Installation Kits & Hose Assemblies with SnapFast™ QD

### Product Part Numbers - Order Using Part Numbers Listed Below

Configuration	Inside Dia.	LENGTH				
		24"	36"	48"	60"	72"
DELUXE KIT *		1650KIT24	1650KIT36	1650KIT48	1650KIT60	1650KIT72
BASIC KIT **	1/2"	1650BPQR24	1650BPQR36	1650BPQR48	1650BPQR60	1650BPQR72
HOSE ASSEMBLY		1650BPQ24	1650BPQ36	1650BPQ48	1650BPQ60	1650BPQ72
DELUXE KIT *		1675KIT24	1675KIT36	1675KIT48	1675KIT60	1675KIT72
BASIC KIT **	3/4"	1675BPQR24	1675BPQR36	1675BPQR48	1675BPQR60	1675BPQR72
HOSE ASSEMBLY		1675BPQ24	1675BPQ36	1675BPQ48	1675BPQ60	1675BPQ72
DELUXE KIT *		16100KIT24	16100KIT36	16100KIT48	16100KIT60	16100KIT72
BASIC KIT **	1"	16100BPQR24	16100BPQR36	16100BPQR48	16100BPQR60	16100BPQR72
HOSE ASSEMBLY		16100BPQ24	16100BPQ36	16100BPQ48	16100BPQ60	16100BPQ72
DELUXE KIT *		16125KIT24	16125KIT36	16125KIT48	16125KIT60	16125KIT72
BASIC KIT **	1-1/4"	16125BPQR24	16125BPQR36	16125BPQR48	16125BPQR60	16125BPQR72
HOSE ASSEMBLY		16125BPQ24	16125BPQ36	16125BPQ48	16125BPQ60	16125BPQ72

### BTU Flow Capacity (Flow rating BTU 0.64 SP. GR. @ 0.5 inch WC pressure drop)

Part #	Inside Dia.	LENGTH					
		12"	24"	36"	48"	60"	72"
1650BPQ	1/2"	98,000	87,000	77,000	68,000	60,000	55,000
1675BPQ	3/4"	260,000	232,000	218,000	180,000	158,000	139,000
16100BPQ	1"	425,000	414,000	379,000	334,000	294,000	279,000
16125BPQ	1-1/4"	783,000	699,000	615,000	541,000	476,000	419,000

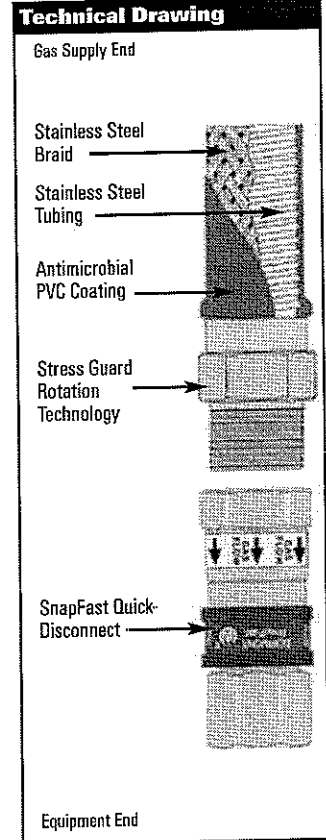

### Approvals & Certifications

- NSF** NSF International Criteria C-2. Special Equipment and/or Devices  
"Component"
- SP** ANSI Z21.69 / CSA 6 16 - Connectors for Moveable Gas Appliances
- US** ANSI Z21.41 / CSA 6 9 - Quick-Disconnect Devices For Use With Gas Fuel
- Meets requirements of ANSI Z223.1 / NFPA 54 - National Fuel Gas Code
- Refer to catalog page 23 for additional approvals & certifications and Dormont gas connector limited lifetime warranty
- SnapFast is not for use in temperatures less than 32°F



### Features & Specifications

- THE DORMONT BLUE HOSE:**
- Tubing: Annealed, 304 stainless steel (ASTM A240)
  - Braiding: Multi-strand, 304 stainless steel wire
  - Coating: Antimicrobial (patent #6,742,815) PVC, melts at 350°F; coating will not hold a flame; blue color indicates braided connector
  - End Fittings: Carbon steel; zinc and yellow dichromate coating
  - Stress Guard: 360° rotation of end fittings at both ends before and after installation (patent pending)
- THE SNAPFAST ONE-HANDED QUICK-DISCONNECT- QD:**
- Quick-Disconnect: Brass body, carbon steel threaded end fittings, and aluminum collar
  - Thermal Shut-off: Polymer insert in QD melts when internal temperatures exceed 350° F, to shut off gas flow
- \* DELUXE KITS INCLUDE:**
- Elbow: Malleable iron - 2 included
  - Restraining Cable: PVC coated, carbon steel, multi-strand cable
  - Valve: 100% full port, brass gas ball valve
- \*\* BASIC KITS INCLUDE:** The Dormont Blue Hose and restraining cable and hardware required for caster-mounted installations

DEMAND THE DIFFERENCE!

1-800-DORMONT  
**DORMONT**  
www.dormont.com

**VULCAN***(Alternate)*

Item #

3

C.S.I. Section 11420

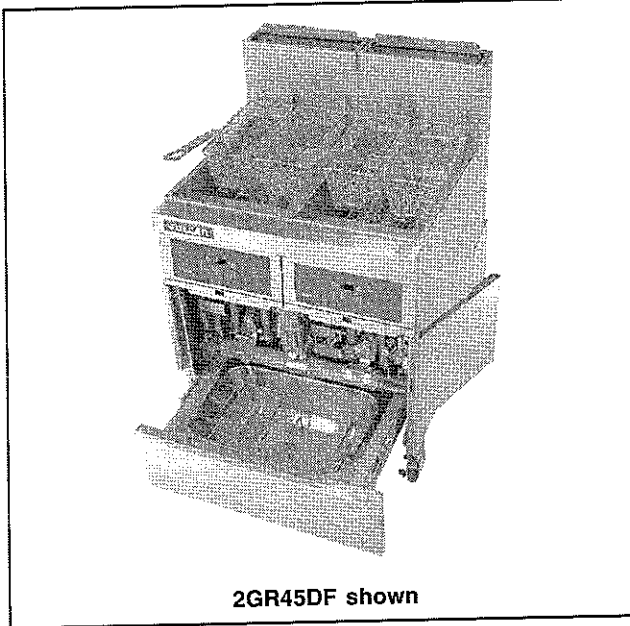
**KLEENSCREEN FILTRATION SYSTEM  
BUILT-IN FILTER SYSTEM FOR GR SERIES FRYERS**

2GR45DF shown

**SPECIFICATIONS:**

Built-in filter system, Vulcan-Hart Model No (# of fryers - 2, 3 or 4) GR (lb. capacity - 45, 65 or 85) (control type - D or C) F (add suffix-F to fryer battery model No., i.e. 2GR45DF) Filter system accommodates: Minimum of two, maximum of four 45 lb. capacity tanks per fryer battery; Minimum of two, maximum of three 65 lb. and 85 lb. capacity tanks per fryer battery. Drawer style filter pan assembly, 80 lbs. capacity on GR45 & GR65 130 lbs. capacity on GR85 Filter vessel constructed of 18 gauge, #304 series stainless steel. Casters 1/3 H.P. motor and pump circulates hot frying compound at the rate of 5.6 gallons per minute, activated by a solenoid push button switch System provided standard with paperless stainless steel mesh filter screen, primary crumb catch basket, tank brush, scoop and clean-out rod. Hands free oil return line connection. Drain valve interlock switch turns fryer off when drain valve is opened Requires 120 volt, 60 Hz, 1 phase power supply

CSA design certified. NSF Listed

**STANDARD FEATURES**

- Filter system accommodates:
  - Minimum of two, maximum of four 45 lb. capacity tanks per fryer battery.
  - Minimum of two, maximum of three 65 lb. and 85 lb. capacity tanks per fryer battery.
- Drain valve interlock switch
- 18 gauge, #304 series stainless steel filter vessel.
- Casters
- Electronic ignition on solid state and computer control fryers
- Drawn (seamless) filter pan. 80 lbs. frying compound capacity on GR45 & GR65 130 lbs. capacity on GR85
- Paperless stainless steel filter screen filters from 2 sides (GR45 & GR65 surface area 330 sq. in.) (GR85 surface area 532 sq. in.)
- 1/3 H.P. motor and pump circulates hot frying compound at a rate of 5.6 gallons per minute, activated by a solenoid push button switch
- Oil discard hose - 6 ft. in length.
- Large primary crumb catch basket.
- Tank brush, stainless steel crumb scoop and clean-out rod
- 120 volt, 60 Hz, 1 phase
- One year limited parts and labor warranty

**VULCAN**UL LISTED  
UL 1004**KLEENSCREEN FILTRATION SYSTEM**



## KLEENSCREEN FILTRATION SYSTEM BUILT-IN FILTER SYSTEM FOR GR SERIES FRYERS

**IMPORTANT**

- 1 A combination valve with pressure regulator is provided with this unit.  
Natural Gas 4.0" (102 mm) W.C.  
Propane Gas 11 0" (254 mm) W.C.
- 2 An adequate ventilation system is required for Commercial Cooking Equipment. Information may be obtained by writing to the National Fire Protection Association, Batterymarch Park, Quincy, MA 02269 When writing refer to NFPA No. 96.
3. All models require a 6" (152 mm) clearance at both sides and rear adjacent to combustible construction.

- 4 All models require a 16" (407 mm) minimum clearance to adjacent open top burner units.
5. This appliance is manufactured for commercial installation only and is not intended for home use

**SERVICE CONNECTIONS:**

- (P1) 1 1/4" (32 mm) NPT common rear gas connection.
- (E1) 120 volt, 60 Hz, 1 phase electrical connection (filter pump)

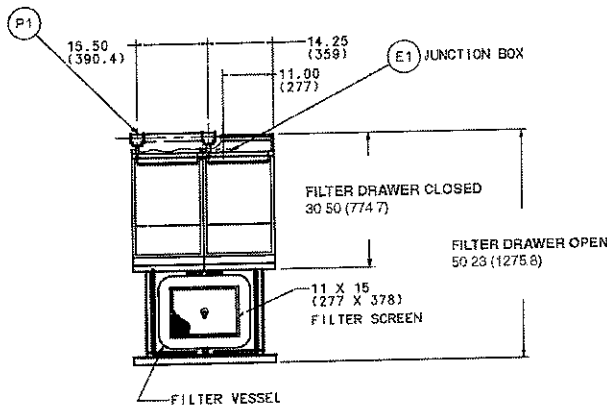

**TOP VIEW  
GR45 SERIES**

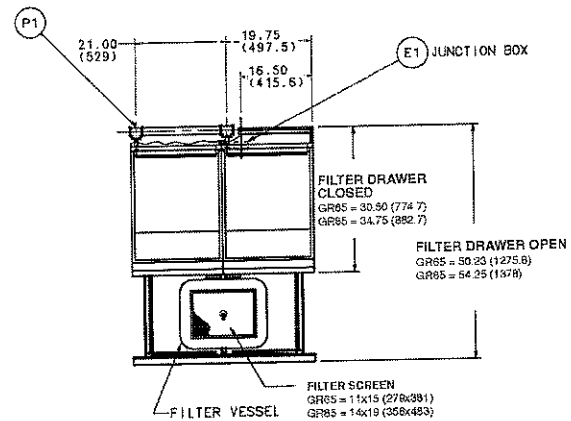

**TOP VIEW  
GR65 & GR85 SERIES**

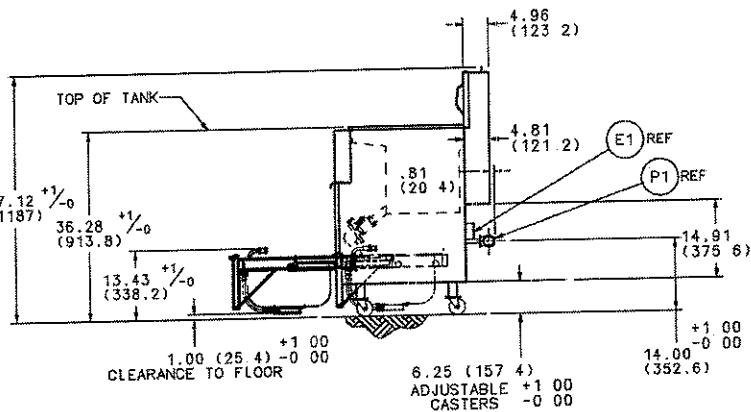
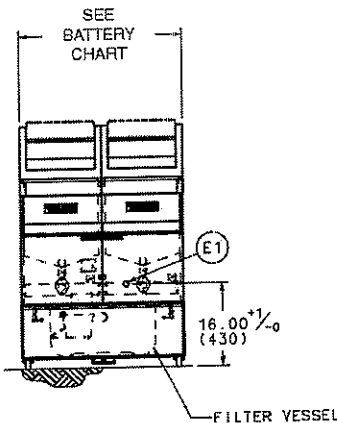

**BATTERY DIMENSIONS:**

Model No.	2 Fryers	3 Fryers	4 Fryers
	Width	Width	Width
GR45	31"	46 1/2"	62"
GR65	42"	63"	-
GR85	42"	63"	-

**FILTER SECTION SPECIFICATIONS:**

Filter Pan Capacity	Filter Area	Motor	Pump	Electric Amps	Electric Power
GR45 & GR65 80 lbs.	330 sq. in.	1/8 H.P. 1750RPM	5.6 gal.	115V/5.0	120V 60Hz 1 phase
GR85 130 lbs.	532 sq. in.				

**NOTE:** In line with its policy to continually improve its products, Vulcan-Hart Company reserves the right to change materials and specifications without notice.

VULCAN-HART COMPANY, P.O. BOX 696, LOUISVILLE, KY 40201, TEL. 1-800-814-2028



# Gas Connectors Specifier Sheet

## Deluxe Installation Kits & Hose Assemblies with SnapFast™ QD

### Product Part Numbers - Order Using Part Numbers Listed Below

Configuration	Inside Dia.	LENGTH				
		24"	36"	48"	60"	72"
DELUXE KIT *		1650KIT24	1650KIT36	1650KIT48	1650KIT60	1650KIT72
BASIC KIT **	1/2"	1650BPQR24	1650BPQR36	1650BPQR48	1650BPQR60	1650BPQR72
HOSE ASSEMBLY		1650BPQ24	1650BPQ36	1650BPQ48	1650BPQ60	1650BPQ72
DELUXE KIT *		1675KIT24	1675KIT36	1675KIT48	1675KIT60	1675KIT72
BASIC KIT **	3/4"	1675BPQR24	1675BPQR36	1675BPQR48	1675BPQR60	1675BPQR72
HOSE ASSEMBLY		1675BPQ24	1675BPQ36	1675BPQ48	1675BPQ60	1675BPQ72
DELUXE KIT *		1610KIT24	1610KIT36	1610KIT48	1610KIT60	1610KIT72
BASIC KIT **	1"	1610BPQR24	1610BPQR36	1610BPQR48	1610BPQR60	1610BPQR72
HOSE ASSEMBLY		1610BPQ24	1610BPQ36	1610BPQ48	1610BPQ60	1610BPQ72
DELUXE KIT *		16125KIT24	16125KIT36	16125KIT48	16125KIT60	16125KIT72
BASIC KIT **	1-1/4"	16125BPQR24	16125BPQR36	16125BPQR48	16125BPQR60	16125BPQR72
HOSE ASSEMBLY		16125BPQ24	16125BPQ36	16125BPQ48	16125BPQ60	16125BPQ72

### BTU Flow Capacity (Flow rating BTU 0.64 SP. GR. @ 0.5 inch WC pressure drop)

Part #	Inside Dia.	LENGTH					
		12"	24"	36"	48"	60"	72"
1650BPQ	1/2"	98,000	87,000	77,000	68,000	60,000	55,000
1675BPQ	3/4"	260,000	232,000	218,000	180,000	158,000	139,000
16100BPQ	1"	425,000	414,000	379,000	334,000	294,000	279,000
16125BPQ	1-1/4"	783,000	699,000	615,000	541,000	476,000	419,000

### Technical Drawing

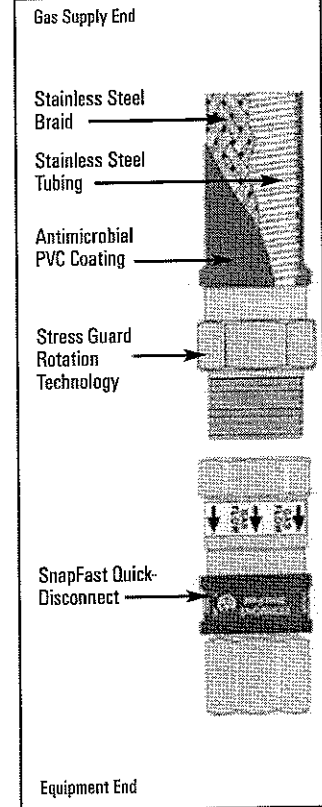

### Approvals & Certifications



NSF International Criteria C-2 Special Equipment and/or Devices

\*Component



ANSI Z21.69 / CSA 6.16 - Connectors for Moveable Gas Appliances

ANSI Z21.41 / CSA 6.9 - Quick-Disconnect Devices For Use With Gas Fuel

Meets requirements of ANSI Z223.1 / NFPA 54 - National Fuel Gas Code

Refer to catalog page 23 for additional approvals & certifications and Dormont gas connector limited lifetime warranty

SnapFast is not for use in temperatures less than 32°F



### Features & Specifications

#### THE DORMONT BLUE HOSE:

- Tubing: Annealed, 304 stainless steel (ASTM A240)
- Braiding: Multi-strand 304 stainless steel wire
- Coating: Antimicrobial (patent #6,742,815) PVC, melts at 350°F, coating will not hold a flame; blue color indicates braided connector
- End Fittings: Carbon steel; zinc and yellow dichromate coating
- Stress Guard: 360° rotation of end fittings at both ends before and after installation (patent pending)

#### THE SNAPFAST ONE-HANDED QUICK-DISCONNECT- QD:

- Quick-Disconnect: Brass body, carbon steel threaded end fittings, and aluminum collar
- Thermal Shut-off: Polymer insert in QD melts when internal temperatures exceed 350° F, to shut off gas flow

#### \* DELUXE KITS INCLUDE:

- Elbow: Malleable iron - 2 included
- Restraining Cable: PVC coated, carbon steel, multi-strand cable
- Valve: 100% full port, brass gas ball valve

#### \*\* BASIC KITS INCLUDE:

The Dormont Blue Hose and restraining cable and hardware required for caster-mounted installations

DEMAND THE DIFFERENCE!

1-800-DORMONT  
**DORMONT**  
www.dormont.com



# SCOTSMAN

AIR, WATER, & REMOTE COOLED MODULAR CONTOUR CUBERS

## CME1056

(Alternate)

VOLUME PRODUCTION • 24 HOUR

Item # 6

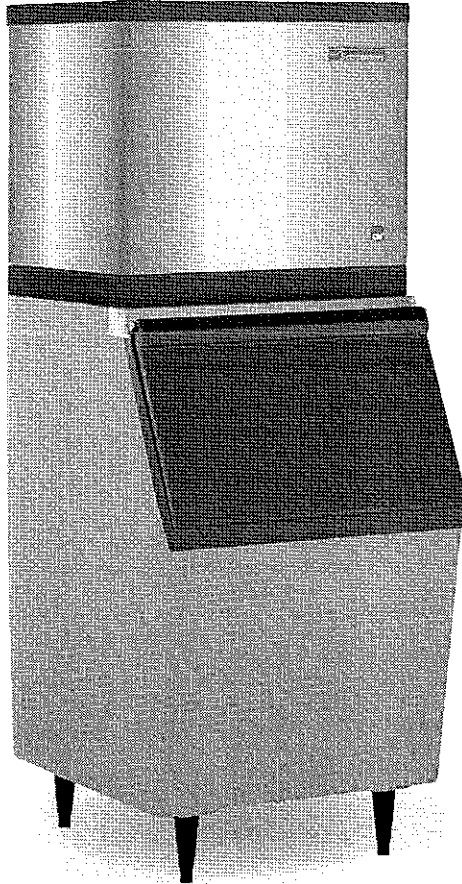

Certified & rated in accordance with ARI standard 810-95	Air-Cooled		Water-Cooled		Remote	
	70°/50° lbs./kg.	ARI 90°/70° lbs./kg.	70°/50° lbs./kg.	ARI 90°/70° lbs./kg.	70°/50° lbs./kg.	ARI 90°/70° lbs./kg.
CME1056-32	975/442	800/363	910/413	820/373	950/431	820/373
CME1056-3	975/442	800/363	910/413	820/373	950/431	820/373

### VALUE THE DIFFERENCE OF CM<sup>3</sup> ICE MACHINES:

- CM<sup>3</sup> series offers the lowest lifetime operating costs based on lower water and electrical usage. Combine that with a competitive purchase price and the best warranty in the industry and you have the lowest lifetime ownership cost. Period.
- AutoIQ™ Control System monitors and controls the ice machines' functions to ensure consistent ice production and reduce operating costs
- CM<sup>3</sup> Evaporator is a hot tin dipped, molecularly bonded plate that has been field tested and proven 99.4% reliable over 5 years.
- Rust-free Polyethylene Base and Food Zone is insulated with 1-1/2" of foam which keeps water and food zone cool to reduce operating costs and is backed by a Lifetime Rust-free Warranty.
- Contemporary styling and stainless steel finish make the CM<sup>3</sup> a perfect addition to any operation.
- Now protected with AquaArmor™ utilizing AgION™, a silver-based anti-microbial compound that reduces the growth of bacteria, microorganisms, algae, mold and slime on ice machine surfaces. AgION is a trademark of AgION Technologies and is registered with the EPA.

### WARRANTY See your dealer for complete warranty details.

- Limited Lifetime Rust Free Warranty on Food Zone.
- 3 years parts and labor on all components.
- 5 years parts and labor on the CME evaporator.
- 5 years parts on the compressor and condenser.

### BIN OPTIONS:

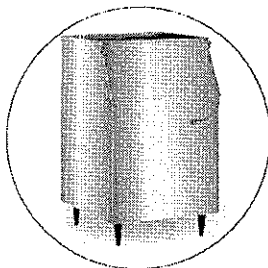

BIN: BH550

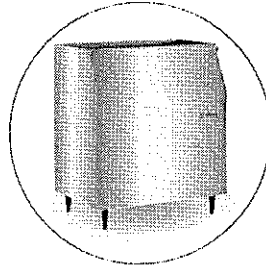

BIN: BH800

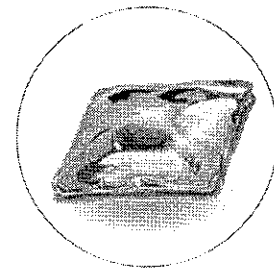

APPROX. CUBE SIZE:  
1 3/8" x 1 3/8" x 5/8" THICK

SCOTSMAN MODULAR BINS					
Model Number	Dimensions W"xD"xH"	ARI Bin Capacity	Application Capacity	Finish	Ship Weight lbs./kg.
HTB555	30 x 34.5 x 44.5	420 LBS.	535 LBS.	HTB	110/50
BH550	30 x 31.5 x 44	410 LBS.	520 LBS.	SS	140/64
BH800*	42 x 31.5 x 44	580 LBS.	740 LBS.	SS	175/79
BH900*	48.2 x 33.75 x 44	740 LBS.	940 LBS.	SS	185/84

(HTB) Linear Low Density Polyethylene—Grey color      \*See Price Schedule For Appropriate Bin Top  
(SS) Stainless Steel with Polyethylene liner.

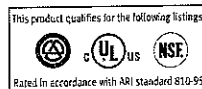

# Ice Machine Specifications

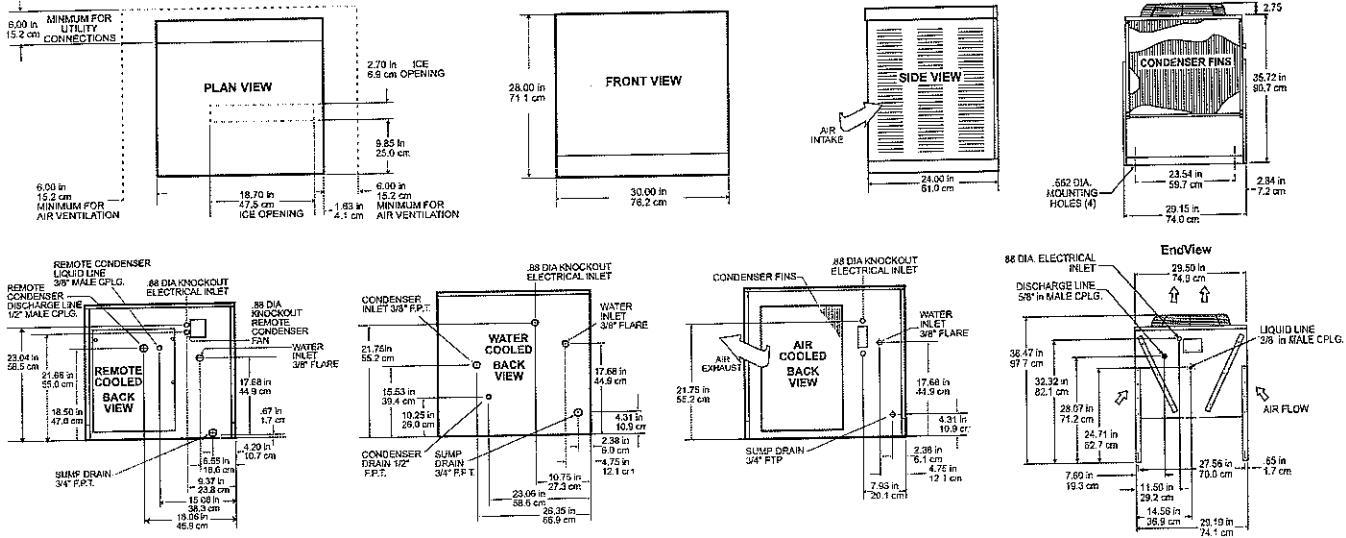

All models: Dimensions: W x D x H Unit: 30" x 24" x 28" Shipping Carton: 33 1/2" x 28" x 33 1/2"

Model Number	Condenser Unit	Basic Electrical Volts/Hz/Phase	Max Fuse Size or HACR Circuit Breaker	Comp. HP	Circuit Wires	Min. Circuit Ampacity	BTU's per hour	Shipping Weight lbs./kg.	Power Consumption KWH/100 lbs 90°F/70°F	Water Usage Gallons/100 lbs. Potable 90°F/70°F	Condenser 90°F/70°F
CME1056AS-32F	AIR	208-230/60/1	20	2 1/2	2	18.75	15,500	280/127	6.1	18.0	-
CME1056WS-32F	WATER	208-230/60/1	20	2 1/2	2	17.25	15,500	280/127	5.1	16.8	140
CME1056RS-32F	REMOTE	208-230/60/1	20	2 1/2	2	17.25	15,500	280/127	6.0	17.9	-
CME1056AS-3F	AIR	208-230/60/3	15	2 1/2	3	13.63	15,500	285/127	6.1	18.0	-
CME1056WS-3F	WATER	208-230/60/3	15	2 1/2	3	12.13	15,500	285/127	5.1	16.8	140
CME1056RS-3F	REMOTE	208-230/60/3	15	2 1/2	3	12.13	15,500	285/127	6.0	17.9	-

All units with Stainless Steel finish

**OPTIONS:**

Stacking Kit: KSCME6-30

**REMOTE CONDENSER**—Comes with adjustable legs

Dimensions: W x D x H: 29.50" x 29.25" x 38.50"

Model Number	For Use With	Cond. Unit	Finish Basic	Electrical Volts/Hz/Phase	No. of Wires	Min. Circuit Ampacity	Max Fuse Size or HACR Circuit Breaker
ERC311-32A	1-CME1056R	Air	Galvanized	208-230/60/1	2	2.6	15

PRE-CHARGED REFRIGERANT TUBE KITS: 25-Foot, RTE25 • 40-Foot, RTE40 • 75-Foot, RTE75. Refrigerant R-404A

Scotsman's ice machines are not designed for outdoor installations. Scotsman remote condensers are designed for outdoor installations.

Machine requires voltage indicated on rating name plate. Failures caused by improper voltage are not considered factory defects. Extended periods of operation at temperatures exceeding limitations constitutes misuse under the terms of Scotsman Manufacturer's Limited Warranty, resulting in a loss of warranty coverage. Specifications and design are subject to change without notice.

Consult Your Local SCOTSMAN Representative At:

**IMPORTANT OPERATING REQUIREMENTS:**

	Minimum	Maximum
Air Temperatures	50°F (10°C)	100°F (37.7°C)
Water Temperatures	40°F (4.4°C)	100°F (37.7°C)
Remote Cond. Temps	-20°F (-28.9°C)	120°F (48.9°C)
Water Pressures	20 PSIG	120 PSIG
Electrical Voltage	-5%	+10%

**YOU'LL VALUE THE DIFFERENCE™**

775 Corporate Woods Parkway • Vernon Hills, IL 60061 • 1-800-SCOTSMAN • Fax: (847) 913-9844  
 Visit our website at: [www.scotsman-ice.com](http://www.scotsman-ice.com) • E-mail: [customer.service@scotsman-ice.com](mailto:customer.service@scotsman-ice.com)



# SCOTSMAN

MODULAR ICE STORAGE BINS

(Alternate)

**BH801**

Item # 6

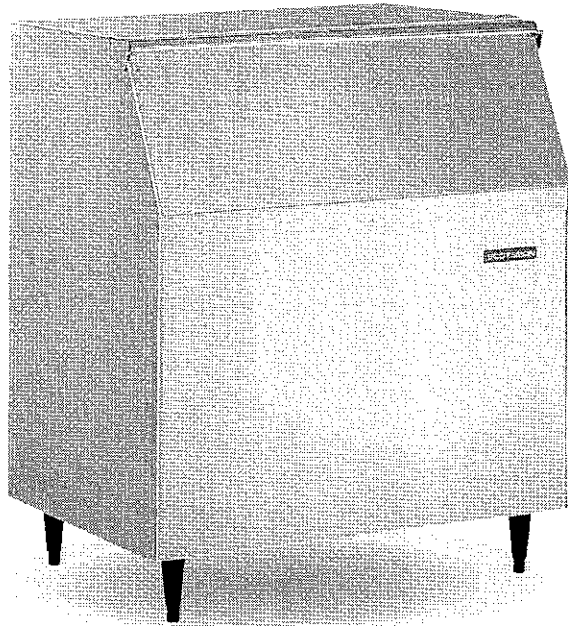

Bin includes 6" black enamel legs w/ adjustable leveling

### IMPROVED DESIGN

- Innovative, patent pending ice baffle that retains the ice in the bin better and can be removed for cleaning without the need for tools reducing the time and cost to maintain the bin.
- Significantly stronger canopy for better ice machine support

### VOLUME STORAGE – AMPLE ICE RESERVE

- Holds 580 pounds per ARI standard 820-95.
- Accepts one or more Modular Cubers, Flakers, or Nugget Ice Makers.

### QUALITY CONSTRUCTION

- NSF approved construction
- Sanitary stainless steel finish
- Polyethylene bin interior.

### WARRANTY PROTECTION *See Dealer for complete warranty details*

- 3 years parts and labor on all components

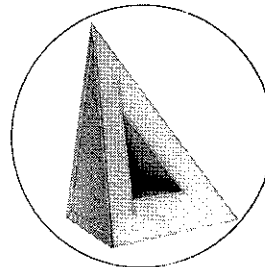

### POLYURETHANE INSULATION

Non-CFC foam insulation is forced between the wall and liner under heat and pressure to form a perfect wall to wall bond, preserving ice supply for long periods.

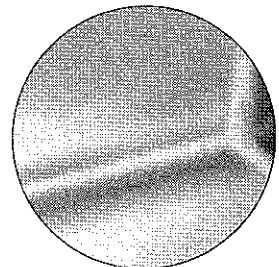

### BIN INTERIOR

The polyethylene bin interior is sanitary and easy to clean. Resists scratches and scuffs from ice scoops.

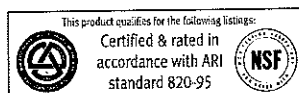

# Bin Specifications

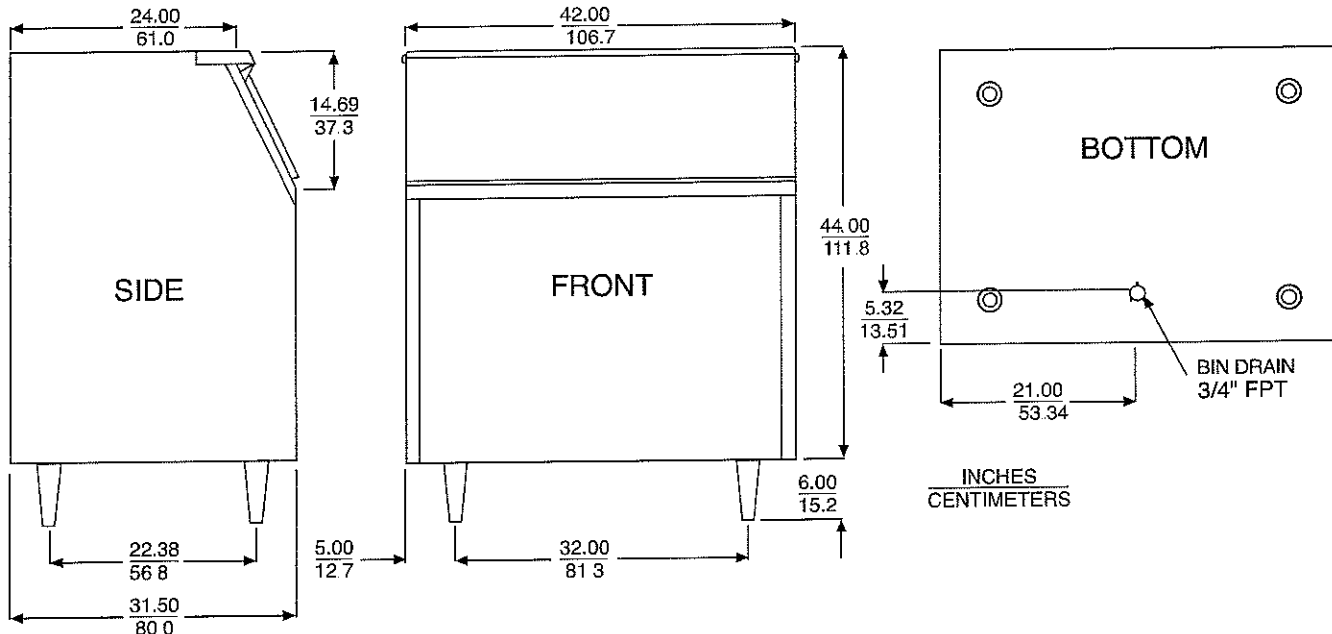

NOTE: Allow 6" minimum space at back for ice machine ventilation and utility connections.

SCOTSMAN MODULAR BIN			Certified & rated in accordance with ARI standard 820-95			
Model Number	Dimensions W" x D" x H"	Cubic Feet	ARI Bin Capacity lbs./kg.	Application Capacity lbs./kg.	Finish*	Ship. Wt lbs./kg.
BH80tS-A	42 x 31.5 x 44	24.2	580/263	740/336	SS	185/84

\*(SS) Grained stainless steel cabinet with a polyethylene liner  
NOTE: Add 6" height for legs.

ARI storage capacity for bins is based on 80% of total volume in cubic feet x 30 lb./ft.<sup>3</sup> average density of ice  
Application capacity for bins is based on 90% of total volume in cubic feet x 34 lb./ft.<sup>3</sup> average density of ice

Scotsman's ice machines and bins are not designed for outdoor installations. Scotsman remote condensers are designed for outdoor installations.

Machine requires voltage indicated on rating name plate. Failures caused by improper voltage are not considered factory defects. Extended periods of operation at temperatures exceeding limitations constitutes misuse under the terms of Scotsman Manufacturer's Limited Warranty, resulting in a loss of warranty coverage. Specifications and design are subject to change without notice.

Consult Your Local SCOTSMAN Representative At:

## ACCESSORIES

Model Number	Description	Application	Ship. Wt. lbs./kg.
KBT15B	Bin Top	Use with MFE400	85/38
KBT28	Bin Top	Filler Kit for 21" Flake & Nugget Machines.	10/5
KBT29	Bin Top	Filler Kit for 30" Cubers, Flakers & Nugget Machines	10/5
KLP4	Heavy-duty leg kit	6" aluminum legs & bracket. Must be used when machines are stacked.	25/11
KLP7	Flanged-feet leg kit	6" black enamel legs with flanged feet.	5/2
KBC1	Caster kit	Raises bin 47/16". Not to be used when machines are stacked.	8/4

**YOU'LL VALUE THE DIFFERENCE™**

775 Corporate Woods Parkway • Vernon Hills, IL 60061 • 1-800-SCOTSMAN • Fax: (847) 913-9844  
Visit our website at: [www.scotsman-ice.com](http://www.scotsman-ice.com) • E-mail: [customer.service@scotsman-ice.com](mailto:customer.service@scotsman-ice.com)



# Arctic Pure®

Ice Machine - Water Filtration



**Manitowoc.**

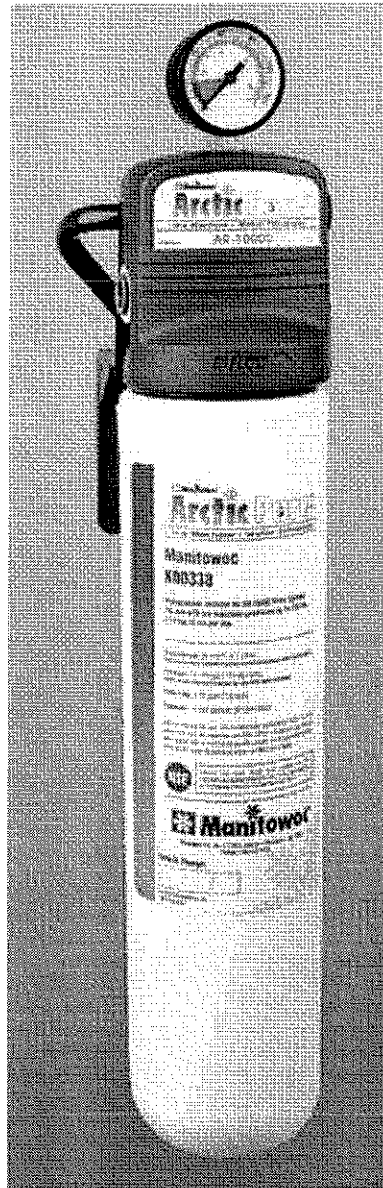

AR-10000

*Over 60% of ice machine maintenance calls are water-related! Arctic Pure® water filters are designed exclusively for ice machine applications and will reduce these calls.*

- Built-in scale inhibitor. Siliphos is designed into the filters to reduce scale build-up even under the hardest water conditions.
- Reduces chlorine taste and odor. All filtration and scale reduction material is NSF and/or FDA compliant and is engineered to reduce chlorine taste and odor. Ice looks and tastes better.
- Graded density carbon block filter. Provides superior dirt holding capacity and fine sediment reduction.
- Sanitary quick change housing. Design minimizes contamination of filter media during filter cartridge change-out. All filters are provided with automatic shut-off and pressure relief valves.

**America's #1 Selling Ice Machine**  
Ice Cube & Flake Machines • Ice Storage Bins • Ice Dispensers





# Manitowoc Arctic Pure®

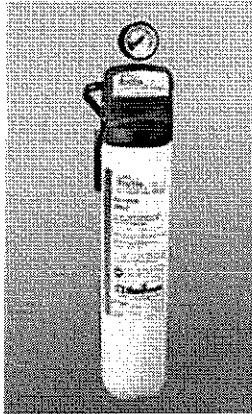

**AR-PRE**  
Pre-filter, dirt and rust sediment reduction



**AR-10000**  
1 micron particle reduction  
14 000 gal. capacity  
20 grams siliphos  
Lbs. of ice per day 0-600

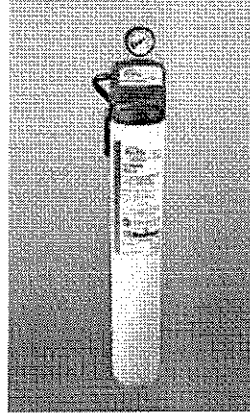

**AR-20000**  
1 micron particle reduction  
20 000 gal. capacity  
40 grams siliphos  
Lbs. of ice per day 601-1000

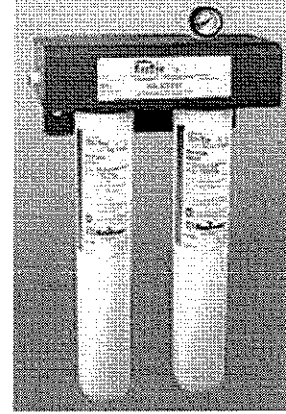

**AR-40000**  
1 micron particle reduction  
40 000 gal. capacity  
80 grams siliphos  
Lbs. of ice per day 1001-2,500

Ice Machine	Model			
	AR-PRE	AR-10000	AR-20000	AR-40000
QM30	◆	◆		
QM45	◆	◆		
Q-130	◆	◆		
Q-210	◆	◆		
Q-270	◆	◆		
S-300	◆	◆		
S-322	◆	◆		
S-422	◆	◆		
S-450	◆	◆		
S-500	◆	◆		
S-600	◆	◆		
S-850	◆		◆	
S-1000	◆		◆	
S-1200	◆			◆
S-1400	◆			◆
S-1600	◆			◆
S-1800	◆			◆
Q-Dual	◆			
IB-600	◆	◆		
IB-800	◆		◆	
IB-1000	◆		◆	
QF-400	◆	◆		
QC-700	◆		◆	
QF-800	◆		◆	
QF-2300	◆			◆

### Specifications

**Maximum operating pressure:**  
25-125 psi (1.7-8.6 bar)

**Maximum operating temperature:**  
35°-100°F (1.7°-38°C)

**Flow Rate:** AR-10000 0.75 gpm (2.84 LPM)  
AR-20000 0.75 gpm (2.84 LPM)  
AR-40000 1.5 gpm (5.68 LPM)

**Cartridge Housing Material:** Talc Filled Polypropylene

**Primary Filter** - 1 micron particle reduction. Filter media is graded density carbon block containing Siliphos scale inhibitor which holds dissolved minerals in suspension (AR-10000/20 grams siliphos, AR-20000/40 grams siliphos, AR-40000/80 grams siliphos - 40 grams per cartridge)

**Inlet/Outlet fittings** - 3/8" John Guest

**Optional Pre-Filter** - An optional pre-filter is recommended for ice machine installations in areas with high particulate matter (dirty water). The pre-filter extends the filtration efficiency and working life of the primary filter cartridge where this condition exists. The Manitowoc pre-filter is a cost-efficient solution to the particulate matter (dirty water) problem because pre-filter replacements are more economical than a primary filter cartridge.

### Replacement Cartridges:

Pre-Filter		K-00337
Primary Filter	AR-10000	K-00338
	AR-20000/40000	K-00339

To insure maximum filtration efficiency, replace the primary filter cartridge every 6 months. A filter gauge will indicate if replacement is necessary prior to six months usage (below 20 psig).

**Important notice:** Read this performance sheet and compare the capabilities of this unit with your actual water treatment needs. It is recommended that you have your water supply tested to determine your actual water treatment needs before purchasing a water treatment unit.

**Warning:** Do not use with water that is microbiologically unsafe or of unknown quality without adequate disinfections before or after the unit.

**Caution:** The filter must be protected from freezing. Failure to do so may result in cracking of the filter housing and water leakage.

**Note:** Before using the Arctic Pure on non-Manitowoc machines consult the ice machine manufacturer for water supply usage requirements.

**Warranty:** 3-Year parts and labor warranty on head, shroud, hardware, and mounting assembly (water filter cartridge not included).

### Dimensions

Model	Dimensions						Mtg. Holes		Weight	
	Height		Width		Depth		Center to Center		lbs.	kgs.
AR-Pre	17.09	43.41	6.72	17.10	4.00	10.16	1.50	3.81	4	1.81
AR-10000	17.09	43.41	5.72	14.50	4.00	10.16	1.50	3.81	5	1.81
AR-20000	21.34	54.2	5.72	14.50	4.00	10.16	1.50	3.81	5	2.27
AR-40000	21.23	54.1	15.88	40	5.00	12.7	Top	29.2	12	5.44
							Bottom	24.8		



AR-PRE	Nominal particulate reductions Class IV.
AR-10000 AR-20000 AR-40000	Chlorine reduction taste and odor reduction Class I

Visit [www.nsf.org](http://www.nsf.org) for listed product claims.

©2005 Manitowoc 605. Combining product improvement may necessitate change of specifications without notice. 2188C



MANITOWOC ICE, INC.  
2110 South 26th Street, P.O. Box 1720  
Manitowoc, WI 54221-1720, USA  
Ph: 920-682-0161 • Fax: 920-682-7588  
Visit us online at [www.manitowocice.com](http://www.manitowocice.com)



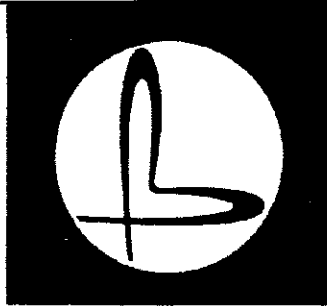

**BLAKESLEE**

50 lbs. 23kg to 60 lbs. 27kg Capacity

POTATO and VEGETABLE

# PEELER

MODEL

**XC-60 & XC-60T**

(Alternate)

DISCHARGE CAN BE DIRECTLY INTO A SINK.

A "T" IN MODEL NO. INDICATES "TIMER" INCLUDED WITH MODEL XC-60T.

## CAPACITY

50 lbs. 23 kg to 60 lbs. 27 kg, 1 to 3 minutes. One peeling cycle will serve 180 to 200 persons when potatoes are mashed in a Blakeslee Food Mixer.

## CONSTRUCTION

Entire machine is constructed of stainless steel. Discharge chute and hinged door are of rust-free, easy to clean aluminum. Removable cover is light weight, easy to clean, molded polystyrene. Motor and drive unit are "sealed off" against moisture to assure trouble-free performance. Entire peeling chamber can be adjusted to any position to insure both the peel trap strainer basket and discharge chute are in the proper position for ease of operation. This can be done without use of any special tools by easily lifting and turning the special peeling chamber.

## DISCHARGE CHUTE

Discharge chute is rust-free, easy to clean aluminum. The hinged aluminum door is not furnished with a gasket so fingertip ease is all that is required to open and close door. A trough is furnished in the discharge chute to catch seepage returning it to the machine. The combination of the trough and the door without a gasket eliminates any future problem of a gasket wearing out and water seeping past the door. Door is light-weight and is self-closing when released from the open position. Discharge chute in 37" 940 mm to 39 1/2" 1050 mm from floor based on adjustment of feet (discharge can be directly into sink).

## MOTOR

1 H.P., grease-packed, ball bearing, ventilated motor. Available for operation of 115/230 volt, 60 cycle, 1 phase or 208/220 volt, 60 cycle, 3 phase.

## SWITCH

Flush mounted toggle switch is located at side of machine. If desired, for convenience sake, this switch can be easily moved to the opposite side of the machine without any special tools for modification of machine enclosure.

## TIMER

Splash proof timer furnished (in single phase only). Timer adjustment from 0 to 5 minutes and has a "hold" position for continuous machine operation.

## DRIVE

Triple V-belt provides proper speed reduction between the motor and the abrasive peeling disc for proper and efficient peeling action. V-belts furnished are of standard size so that if replacement is necessary, these are readily available at local hardware stores or gas stations. Belt adjustment or replacement can be accomplished without dismantling the machine. Stainless steel drive shaft is mounted on sealed, splash proof, self-lubricating ball bearings. Design of the machine, coupled with seal system, insures water tight drive area.

Item # 7

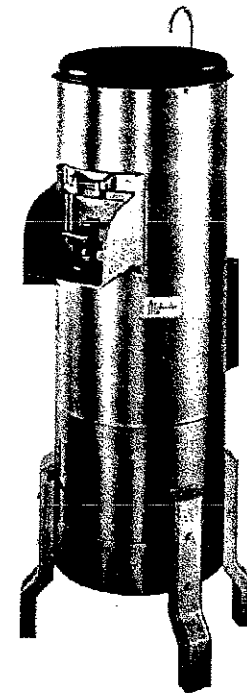

## ABRASIVE DISC

A heavy duty, rust-free cast aluminum abrasive peeling disc is furnished. Abrasive carborundum is permanently cast into the disc. Aluminum provides proper strength for long life, yet is light in weight for ease in removal.

## PEEL TRAP

A deluxe stainless steel peel trap strainer basket is included as standard equipment. Stainless steel insures resistance to rust and eliminates possibility of necessary replacement in the future; also provides necessary strength to resist daily abuse through cleaning.

## APPROX. SHIPPING WEIGHTS

Domestic crated	205 lbs. 93 kg	Export cube	33.4 ft. 95m <sup>3</sup>
Export crated	242 lbs. 110 kg	(L32", W29", H62")	
Export boxed	256 lbs. 116 kg	813 mm 736 mm 1575 mm	

There's no substitute for quality — in food or in finer machinery with which to prepare it.

That's why Blakeslee-Built Vegetable Peelers give you more for your dollar. They're built solid. Each component is perfectly honed and precision-engineered to last for years and years. For Blakeslee has built into these Peelers extra protection for parts... greater safety in handling for the operator... superior construction for longer life.

PP5C

# Blakeslee Potato and Vegetable Peeler

18

MODEL  
**XC-60 & XC-60T**

Compare Blakeslee feature for feature with any other make of peeler...

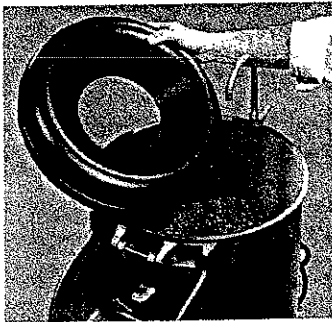

**EASY-TO-CLEAN, CAST ALUMINUM DISCHARGE CHUTE**

Hinged door operates with fingertip ease. Door requires no gaskets — eliminating gasket wearout with resulting water seepage past the door. Trough furnished in discharge chute to catch seepage, returning it to machine. Door is self-closing when released from open position.

Reinforced rim of peeling chamber and water spigot are precision-built to withstand hardest service without impairment. Another example of extra-value Blakeslee design and engineering.

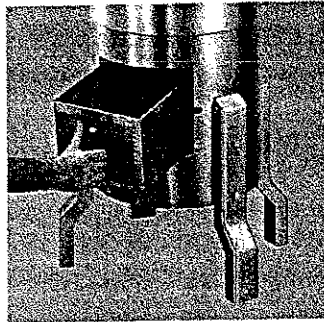

**DELUXE STAINLESS STEEL STRAINER BASKET**

Is standard equipment. Easy to clean out. It's extra large, sturdy. Slides in and out of chamber effortlessly.

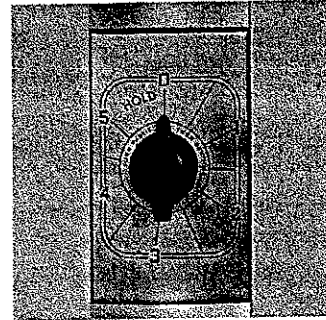

**SPLASHPROOF TIMER HAS ADJUSTMENT**

From 0 to 5 minutes and has a "hold" position for continuous machine operation. (Can be furnished in place of switch in 60-cycle, single phase motor only at slight additional charge.)

**MODEL XC-60T** furnished with a timer with a 0 to 5 minute adjustment and a "hold" position for continuous operation. (Single phase only)

**MODEL XC-60** supplied with an "on and off" switch in lieu of timer. (Single or 3 phase).

SPECIFICATIONS SUBJECT TO CHANGE WITHOUT NOTICE.

All Blakeslee peelers are designed to be in compliance with NSF UL CSA & ASSE Standards

Dimensions are for standard discharge height. For additional height on discharge, add 2 1/2" 65mm to all vertical dimensions.

Drawing not to Scale

No.	Connection	Fitting	Function
1	Cold Water	1/2" 13mm I.P.S.	Peel Flushing Spray
2	Waste-Sewer	2" 50mm N.P.T.	Cylinder Drain
3	Electrical	1 H.P. Motor	3-Wire-3" 75mm Electrical Box

**XC-60**



**BLAKESLEE**  
1844 South Laramie Avenue  
Chicago, IL 60804  
Phone: (708) 656-0660  
FAX: (708) 656-0017

**BLAKESLEE**  
66 Crockford Boulevard  
Scarborough, Ontario, Canada M1R 3C3  
Phone: (416) 751-2625  
FAX: (416) 751-8539

Printed in U.S.A.  
5-97-3M-TR



(Alternate)

Project	Item #	Quantity
	10	

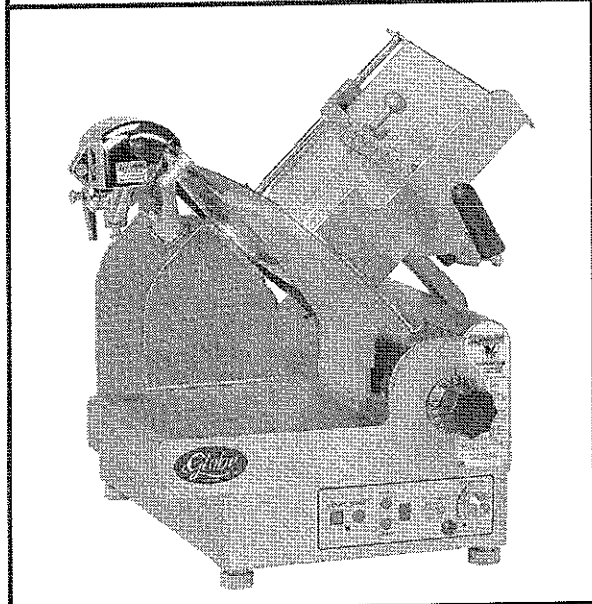

**4975  
Automatic  
Slicer**

**Protech™ Model**

4975 - Variable Speed Slicer



Made in the U S A.

GLOBE FOOD EQUIPMENT COMPANY

**Automatic Slicer**

**Standard Features**

- Gear driven
- 1/2 HP knife motor, 7 amps
- Exclusive stainless steel construction
- Precision gear thickness adjustment
- Slices tissue thin up to 1 1/4" thick
- Table lockout
- Built in antimicrobial protection
- Knife cover interlock
- Signature knife sharpening system
- 12" hollow ground knife
- Permanently attached knife ring guard
- Full gravity feed, 45° angle
- 3 lb. stainless steel end weight
- Return to home food chute
- Home position start
- Automatic shut off
- Auto engage lever
- Touch pad controls
- Lift lever to facilitate cleaning
- Red indicator light
- No voltage release
- 7 foot cord and plug

**Options and Accessories**

- Prison package
- High moisture application package (includes stainless steel knife)
- 15" food chute in lieu of 12" chute
- Aluminum food chute in lieu of stainless steel chute
- Stainless steel knife in lieu of carbon steel
- Front mounted end weight assembly in lieu of standard end weight
- Low food fence
- High food fence
- 3" extension legs
- 10 lb. portion control scale
- Slicer cover

**Standard Warranty**

- 2 years parts and 1 year labor plus 15 years on the gears

Approved By: \_\_\_\_\_

Date: \_\_\_\_\_



**GLOBE FOOD EQUIPMENT COMPANY**  
www.globeslicers.com

2153 Dryden Rd  
Dayton, OH 45439  
Phone: 937-299-5493  
Phone: 800-347-5423  
Fax: 937-299-4147

**4975**



# Automatic Slicer

4975

## Specifications

**Finish:** Exclusive #304 stainless steel base with radiused corners improves sanitation and durability. Other stainless steel parts include the food chute, slicer table, end weight, and knife cover.

**Motors:** **Knife Motor:** Powerful 1/2 HP, 115/60/1, 7 amps. **Chute Motor:** Two speed DC fractional horsepower 1 amp. Both motors have permanently lubricated sealed ball bearings.

**Knife Drive:** Cross axis helical gear drive design. This positive drive design assures nonslip, trouble free operation.

**Slice Thickness:** Precision gear adjustment holds thickness setting for consistent cuts and allows hot or cold foods to be sliced from tissue thin up to 1 1/4" thick.

**Antimicrobial Protection:** Table adjustment knob, auto engage lever knob, sharpener cover knob, and food chute handle have antimicrobial protection built in.

**Full Gravity Feed:** Full 45° angle feed requires less mechanical pressure. Equipped with a 3 lb stainless steel end weight to minimize waste and hold product. The end weight swings away for storage behind chute. The food chute handle is ergonomically designed.

**Touch Pad Controls:** Start/stop touch pad controls activate knife motor. **Chute Speed:** Controlled by faster/slower touch pad controls.

**Cord & Plug:** Attached 7 foot flexible 3 wire cord and plug fits a grounded receptacle.

**Lift Lever:** A handle activates two large wheels, lifting the front of the unit to facilitate safe and easy cleaning underneath the slicer.

**Knife Cover Interlock:** Slicer will not operate with knife cover removed.

**Return to Home Chute:** Food chute automatically returns to position closest to the operator, home, when slicer is turned off. The chute must be in home position to start the slicer.

**Table Lockout:** Once table is closed and the knife cover is removed, the table cannot be opened. Fully protects knife during cleaning.

**Automatic Shut Off:** Slicer automatically shuts off after 10 seconds of no chute movement.

**Knife Ring Guard:** Permanently mounted knife ring guard protects the non-slicing portion of the knife. Slicer table protects leading edge of knife when completely closed.

**Top Mounted Sharpener:** Sharpener is made of all metal and is permanently mounted on the slicer. A single lever activates the large grinding and honing stones.

**Hollow Ground Knife:** Nominal 12" diameter special hardened steel alloy with stain resistant finish and sanitary hub.

**No Voltage Release:** Prevents inadvertent reactivation of slicer in the event of power or interlock interruption. Operator must restart slicer.

**Capacity:** 8.75"H x 12.5"W or 7 1/2" Dia (22.2cm x 31.8cm or 19cm)

**Red Indicator Light:** A readily visible light illuminates when knife is rotating.

**Automatic Chute:** Chute travels 20 to 60 strokes per minute utilizing a separate DC motor with a heavy duty permanently lubricated chain and sprocket drive system. Chute can quickly be engaged or disengaged for manual operation with the auto engage lever.

**Dimensions:**  
 Foot Print = 14" x 21.62"  
 (35.6 cm x 54.9 cm)  
 Overall Length = 28.25" (71.8 cm)  
 Overall Width = 21.5" (54.6 cm)  
 Overall Height = 24" (61 cm)  
 Freight Class: 77.5  
 Net Weight: 153 lbs. (69.4 kgs.)  
 Shipping Weight: 165 lbs (74.7 kgs.)  
 Shipping Dimensions:  
 28"W x 25"D x 34"H  
 (71.1cm W x 63.5cm D x 86.4cm H)

**Factory Installed Options:**  
**LONGCHUTE** 15" food chute  
**SSK** Stainless steel knife  
**FMEW** Front mounted end weight  
**ALUM** Aluminum food chute  
**MEATROOM** High moisture application package  
**PRISON** Prison package

**Accessories:**  
**1326** High fence (12" x 3")  
**1047** Low fence (12" x 1 3/8")  
**873-SET** 3" extension legs  
**PS10** 10 lb. Portion control scale  
**SC-GLOBE** Slicer cover

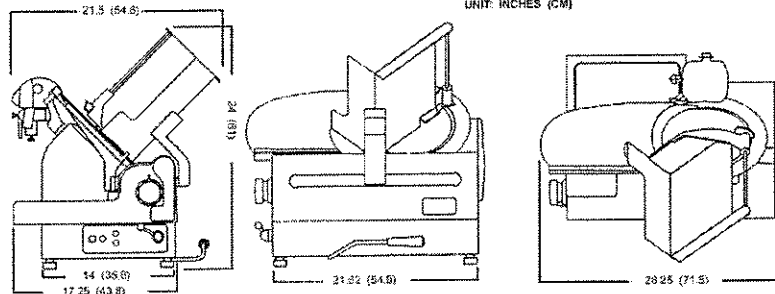

**GLOBE FOOD EQUIPMENT COMPANY**  
[www.globeslicers.com](http://www.globeslicers.com)

2153 Dryden Rd  
 Dayton, OH 45439  
 Phone: 937-299-5493  
 Phone: 800-347-5423  
 Fax: 937-299-4147

Printed in U.S.A. 10-2005

Specifications are subject to change without notice.



Project: \_\_\_\_\_  
 Location: \_\_\_\_\_  
 Item #: 11  
 Quantity: \_\_\_\_\_

**Roll-in Refrigerators**

*(Alternate)*

**RIS MODELS —**

**RIS-1D-S7**

**RIS-2D-S7**

**RIS-3D-S7**

Stainless steel exterior and interior.

**RISA MODELS —**

**RISA-1D-S7**

**RISA-2D-S7**

**RISA-3D-S7**

Stainless steel exterior. Aluminum interior.

**RIA MODELS —**

**RIA-1D-S7**

**RIA-2D-S7**

**RIA-3D-S7**

Stainless steel fronts and doors. Aluminum sides and interior

**Half Door, Roll-Thru and Remote Models Available**

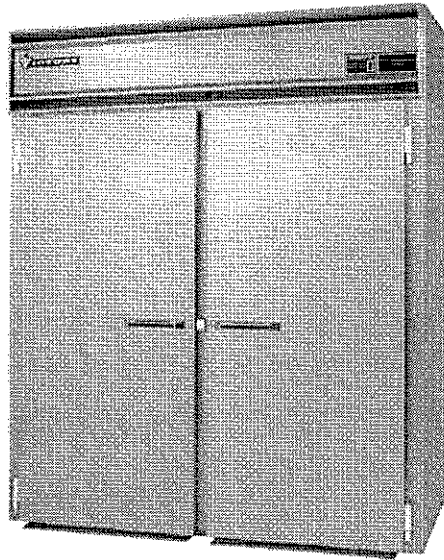

RIS-2D-S7

**RIS and RISA Models**

- Digital Thermometer/Battery Back-up

**RIA Models**

- Dial Thermometer

**Standard Features (all models)**

- Energy Saver Switch
- Stainless Steel Case Front and Door(s)
- Lifetime Heavy-Duty Lifetime Cam Lift Hinges
- Lifetime Safety Grip Handle(s)
- Self-Closing Doors with Safety Stops
- Adjustable Wiper Gasket(s)
- Removable Ramps(s)
- Energy Saving Thermal Breaker Strips
- Door Opening Accepts Carts up to 27" w x 29" d x 64" h
- Heavy-Duty Cylinder Locks
- One Piece Self-Adjusting Magnetic Door Gaskets
- High Impact ABS Interior Door Liner
- Plasticized Fin Coil
- Environmentally Friendly R-134a Refrigerant
- Non-Electric Condensate Evaporator
- Stainless Steel Floor
- Cord and Plug Attached on 115V Models 12 Amps or Less

**Optional Features and Accessories**

- Dial or Digital Thermometer
- Hinged Glass Doors with Cylinder Locks
- Change Door Swing
- Shelf Pilaster Strips
- Adjustable Stainless Steel Wire Shelves
- Stainless Steel Angle Pan Slides
- Zinc Plated Wire Pan Slides
- Stainless Steel Case Back
- Remote and Roll-Thru Models

Note: All 2 & 3 section "Roll Thru" models only have stainless steel interiors

**Cabinet:**

Each Victory cabinet is internally supported, braced and assembled into a single rigid unit. The cabinet front and doors are constructed of heavy gauge polished stainless steel to maintain an attractive appearance after years of heavy use. Foamed-in-place polyurethane insulation throughout the cabinet and doors ensures the ultimate in energy efficiency.

**Doors:**

The self-closing doors are securely mounted on rugged cam-lift hinges, which have a lifetime guarantee. Each door has a heavy-duty cylinder lock and self-adjusting magnetic gasket to prevent the cold air from escaping. Humidity control wires located around the door jamb prevent condensation from forming on the cabinet front and are concealed by a high impact, non-conductive thermal breaker strip. The interior door liner is constructed of durable ABS material, which resists denting and scratching and is

easy to clean. Each safety grip handle is guaranteed for life. Removable ramps are provided on the bottom of each door opening.

**Refrigeration System:**

All components of the self-contained refrigeration system are mounted on top of the cabinet. The air circulating fans and the forced convection-cooling coil are contained in an insulated housing separate from the product zone allowing for maximum food storage capacity. All condensate water is disposed of automatically by the energy efficient non-electric condensate evaporator, no plumbing is required.

Approvals:



Victory Refrigeration specification sheets are available online at [www.victory-refrig.com](http://www.victory-refrig.com)

Victory Refrigeration, Inc.

Roll-in Refrigerators

CHARACTERISTICS	ONE SECTION		TWO SECTION		THREE SECTION	
	Roll-In	Roll-Thru	Roll-In	Roll-Thru	Roll-In	Roll-Thru
Width, Overall	36 1/2	36 1/2	68 1/2	68 1/2	101 1/2	77 1/2
Depth, Overall (incl. handles)	35 1/2	39 1/2	35 1/2	39 1/2	35 1/2	39 1/2
Height, Overall	84	84	84	84	84	84
Depth, Door(s) Open 90°	65 1/2	98 1/2	65 1/2	98 1/2	65 1/2	84 1/2
Depth Case Over Ramp	35 1/2	38 1/2	35 1/2	38 1/2	35 1/2	38 1/2
Clear Door Width	27 1/4	27 1/4	27 1/4	27 1/4	27 1/4	27 1/4
Clear Full Door Height	65 1/2	65 1/2	65 1/2	65 1/2	65 1/2	55 1/2
Capacity Net (cubic feet)	33.6	36.2	67.2	72.4	100.9	75.9
No. of Full Doors	1	2	2	4	3	6
Cabinet Voltage	115/60/1	115/60/1	115/60/1	115/60/1	115/60/1	115/60/1
Feed Wires	2	2	2	2	3	2
Condensing Unit Voltage	115/60/1	115/60/1	115/60/1	115/60/1	208-230/60/1	208-230/60/1
Condensing Unit Size (HP)	1/2	1/2	1/2	1/2	3/4	1/2
Total Amperes	9.2	12.0	11.9	12.6	10.6	12.1

Crated dim. & wts.	Ht.	Width	Depth	Cu.Ft.	Lbs
One Section	87	41 1/2	44 1/2	94.1	450
Two Section	87	74 1/2	44 1/2	168.1	750
Three Section	87	107	44 1/2	241.1	1140

Approximate Roll-Thru weights, add 15%

**FOR REMOTE MODELS**- Substitute an "R" for the "S" in suffix. For example: Model RIS-1D-S7 (self-contained) would be RIS-1D-R7 remote cabinet. Air circulating fans expansion valve and plasticized coil are provided. Condensing units not supplied. The following units are recommended with 1/2" O.D Suction line 1/4" O.D Liquid line

REMOTE REFRIGERATION

	Cond. Unit	BTUH	Cabinet	Amps
One Section	1/2 H.P.	2540	115/60/1	2.2
Two Section	1/2 H.P.	4400	115/60/1	3.0
Three Section	3/4 H.P.	5800	115/60/1	4.3

For Remote Roll-Thru-Consult factory

Dimensional tolerance ± 1/4" Metric dimensions (MM)

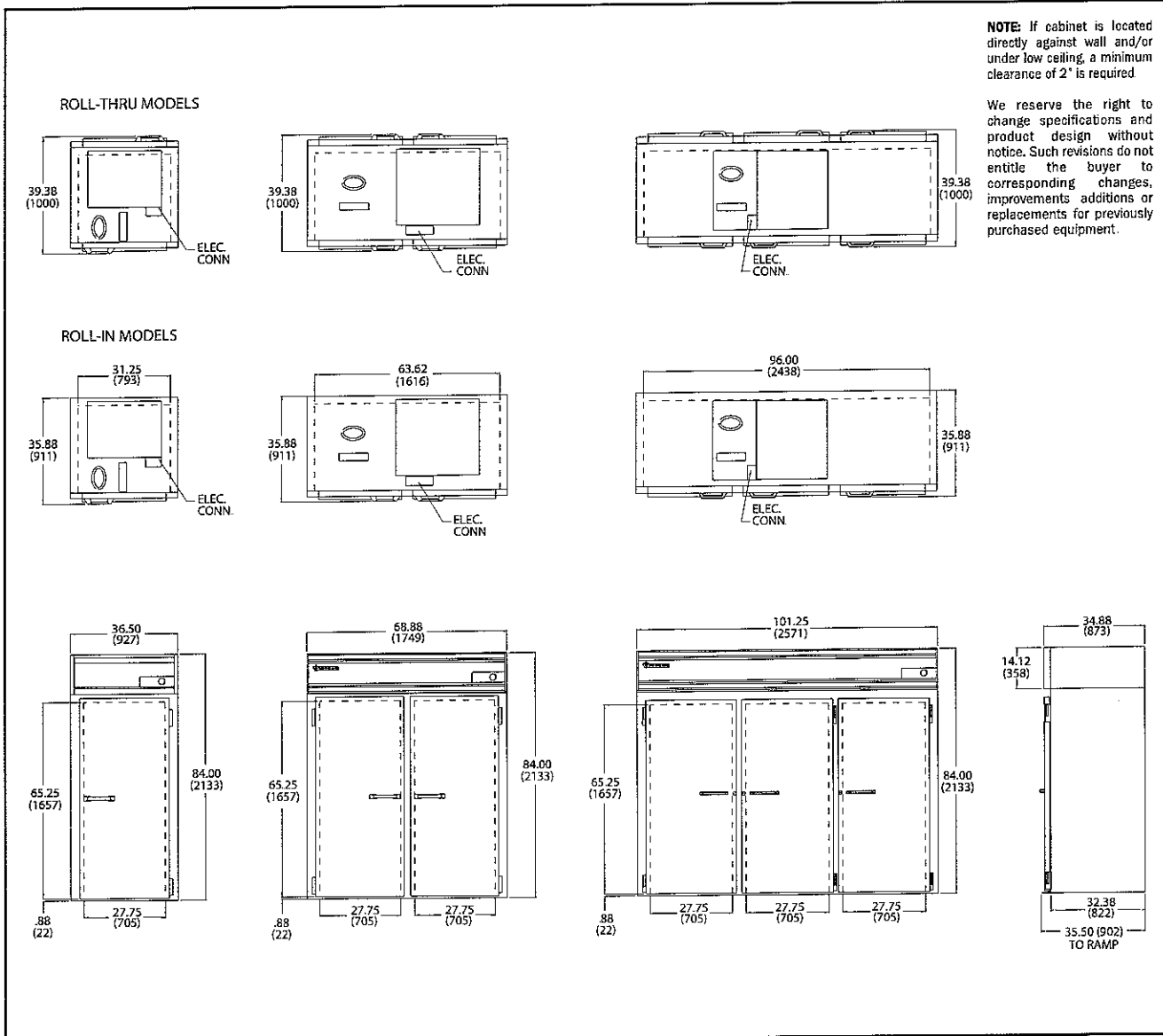

Continuous product development may necessitate specification changes and design without notice.

 Victory participates in the KCL CADALOG the most current source of CAD symbols for foodservice designers worldwide. Symbols include standard equipment in plan, side, front and 3-D views layered for FEDA/FCSI recommended guidelines.

PART OF AGA FOODSERVICE GROUP

Copyright January 2004  
Printed in U.S.A. 010423

**BID BOND**

KNOW ALL MEN BY THESE PRESENTS, That we, the undersigned, Hooten Equipment Company, LLC  
of Charleston, WV, as Principal, and Ohio Farmers Insurance Company  
of Westfield Center, OH, a corporation organized and existing under the laws of the State of  
OH with its principal office in the City of Westfield Center, as Surety, are held and firmly bound unto the State  
of West Virginia, as Obligee, in the penal sum of Five Percent of Amount Bid (\$ 5%) for the payment of which  
well and truly to be made we jointly and severally bind ourselves, our heirs administrators executors, successors and assigns

The Condition of the above obligation is such that whereas the Principal has submitted to the Purchasing Section of the  
Department of Administration a certain bid or proposal, attached hereto and made a part hereof, to enter into a contract in writing for  
RFQ# COR61336 - Mt. Olive Correctional Complex - Cafeteria/Kitchen Equipment - According to Plans &  
Specifications

NOW THEREFORE,

(a) If said bid shall be rejected, or  
(b) If said bid shall be accepted and the Principal shall enter into a contract in accordance with the bid or proposal attached  
hereto and shall furnish any other bonds and insurance required by the bid or proposal, and shall in all other respects perform the  
agreement created by the acceptance of said bid, then this obligation shall be null and void, otherwise this obligation shall remain in full  
force and effect It is expressly understood and agreed that the liability of the Surety for any and all claims hereunder shall in no event,  
exceed the penal amount of this obligation as herein stated.

The Surety, for the value received, hereby stipulates and agrees that the obligations of said Surety and its bond shall be in no  
way impaired or affected by any extension of the time within which the Obligee may accept such bid, and said Surety does hereby  
waive notice of any such extension

IN WITNESS WHEREOF, Principal and Surety have hereunto set their hands and seals, and such of them as are corporations  
have caused their corporate seals to be affixed hereunto and these presents to be signed by their proper officers this  
14th day of March, 2007

Principal Corporate Seal

Hooten Equipment Company, LLC  
(Name of Principal)

By: [Signature]  
(Must be President or  
Vice President)

Vice President  
(Title)

Surety Corporate Seal

Ohio Farmers Insurance Company  
(Name of Surety)

By: [Signature]  
Patricia A. Moye WV Resident Agent Attorney-in-Fact

IMPORTANT -- Surety executing bonds must be licensed in West Virginia to transact surety insurance Corporate seals must be affixed,  
and a power of attorney must be attached.

General Power of Attorney

Westfield Insurance Co. Westfield National Insurance Co. Ohio Farmers Insurance Co. Westfield Center, Ohio

CERTIFIED COPY

Know All Men by These Presents, That WESTFIELD INSURANCE COMPANY, WESTFIELD NATIONAL INSURANCE COMPANY and OHIO FARMERS INSURANCE COMPANY, corporations, hereinafter referred to individually as a "Company" and collectively as "Companies," duly organized and existing under the laws of the State of Ohio, and having its principal office in Westfield Center, Medina County, Ohio, do by these presents make, constitute and appoint LARRY D. KERR, GREGORY T. GORDON, H. RANDOLPH NEVILLE, PATRICIA A. FINCKE, STEPHEN B. STOGDEN, PATRICIA A. MOYE, ALLAN L. MC VEY, TAMMY M. LLOYD, KIMBERLY J. WILKINSON, JOINTLY OR SEVERALLY

of CHARLESTON and State of WV its true and lawful Attorney(s)-in-Fact, with full power and authority hereby conferred in its name, place and stead, to execute, acknowledge and deliver any and all bonds, recognizances, undertakings, or other instruments or contracts of suretyship-

LIMITATION: THIS POWER OF ATTORNEY CANNOT BE USED TO EXECUTE NOTE GUARANTEE, MORTGAGE DEFICIENCY, MORTGAGE GUARANTEE, OR BANK DEPOSITORY BONDS.

and to bind any of the Companies thereby as fully and to the same extent as if such bonds were signed by the President, sealed with the corporate seal of the applicable Company and duly attested by its Secretary, hereby ratifying and confirming all that the said Attorney(s)-in-Fact may do in the premises. Said appointment is made under and by authority of the following resolution adopted by the Board of Directors of each of the WESTFIELD INSURANCE COMPANY, WESTFIELD NATIONAL INSURANCE COMPANY and OHIO FARMERS INSURANCE COMPANY:

"Be It Resolved, that the President, any Senior Executive, any Secretary or any Fidelity & Surety Operations Executive or other Executive shall be and is hereby vested with full power and authority to appoint any one or more suitable persons as Attorney(s)-in-Fact to represent and act for and on behalf of the Company subject to the following provisions:

The Attorney-in-Fact. may be given full power and authority for and in the name of and on behalf of the Company, to execute, acknowledge and deliver, any and all bonds, recognizances, contracts, agreements of indemnity and other conditional or obligatory undertakings and any and all notices and documents canceling or terminating the Company's liability thereunder, and any such instruments so executed by any such Attorney-in-Fact shall be as binding upon the Company as if signed by the President and sealed and attested by the Corporate Secretary."

"Be it Further Resolved, that the signature of any such designated person and the seal of the Company heretofore or hereafter affixed to any power of attorney or any certificate relating thereto by facsimile, and any power of attorney or certificate bearing facsimile signatures or facsimile seal shall be valid and binding upon the Company with respect to any bond or undertaking to which it is attached" (Each adopted at a meeting held on February 8, 2000).

In Witness Whereof, WESTFIELD INSURANCE COMPANY, WESTFIELD NATIONAL INSURANCE COMPANY and OHIO FARMERS INSURANCE COMPANY have caused these presents to be signed by their Senior Executive and their corporate seals to be hereto affixed this 08th day of NOVEMBER A.D., 2006

Corporate Seals Affixed



WESTFIELD INSURANCE COMPANY WESTFIELD NATIONAL INSURANCE COMPANY OHIO FARMERS INSURANCE COMPANY

Richard L. Kinnaird, Jr.

By: Richard L. Kinnaird, Jr., Senior Executive

State of Ohio County of Medina ss.:

On this 08th day of NOVEMBER A.D., 2006, before me personally came Richard L. Kinnaird, Jr. to me known, who, being by me duly sworn, did depose and say, that he resides in Medina, Ohio; that he is Senior Executive of WESTFIELD INSURANCE COMPANY, WESTFIELD NATIONAL INSURANCE COMPANY and OHIO FARMERS INSURANCE COMPANY, the companies described in and which executed the above instrument; that he knows the seals of said Companies; that the seals affixed to said instrument are such corporate seals; that they were so affixed by order of the Boards of Directors of said Companies; and that he signed his name thereto by like order

Notarial Seal Affixed



William J. Kahelin

William J. Kahelin, Attorney at Law, Notary Public My Commission Does Not Expire (Sec 147 03 Ohio Revised Code)

State of Ohio County of Medina ss.:

I, Frank A. Carrino, Secretary of WESTFIELD INSURANCE COMPANY, WESTFIELD NATIONAL INSURANCE COMPANY and OHIO FARMERS INSURANCE COMPANY, do hereby certify that the above and foregoing is a true and correct copy of a Power of Attorney, executed by said Companies, which is still in full force and effect; and furthermore, the resolutions of the Boards of Directors, set out in the Power of Attorney are in full force and effect.

In Witness Whereof, I have hereunto set my hand and affixed the seals of said Companies at Westfield Center, Ohio, this 14th day of March A.D., 2007



Frank A. Carrino Secretary