



State of West Virginia
 Department of Administration
 Purchasing Division
 2019 Washington Street East
 Post Office Box 50130
 Charleston, WV 25305-0130

Request for Quotation

RFQ NUMBER:
COR61335

PAGE:
1

ADDRESS CORRESPONDENCE TO ATTENTION OF:
**JOHN ABBOTT
 304-558-2544**

PROPERTY

RFQ COPY
 TYPE NAME/ADDRESS HERE

**Douglas Equipment
 301 North Street
 Bluefield, WV 24701
 (304) 327-0149 1-(800) 962-8618**

SHIP TO

**DIVISION OF CORRECTIONS
 617 LEON SULLIVAN WAY
 CHARLESTON, WV 25301 304-558-8045**

DATE PRINTED 02/07/2007	TERMS OF SALE	SHIP VIA	F.O.B.	FREIGHT TERMS
-----------------------------------	---------------	----------	--------	---------------

BID OPENING DATE: **03/07/2007** BID OPENING TIME **01:30PM**

LINE	QUANTITY	UOP	CAT NO.	ITEM NUMBER	UNIT PRICE	AMOUNT
REQUEST FOR QUOTATION						
THE PURCHASING DIVISION IS SOLICITING BIDS FOR THE HUTTONSVILLE CORRECTIONAL CENTER TO PROVIDE THE INSTALLATION OF CAFETERIA / KITCHEN EQUIPMENT.						
MANDATORY ON-SITE PRE-BID: 2/23/2007; 2:00 PM						
ATTACHMENTS: 1. SPECIFICATIONS 2. AFFIDAVIT						
IF AN EQUAL BRAND & MODEL IS BID, SPECIFICATION DOCUMENTATION AND A COLORED BROCHURE SHALL BE SUBMITTED WITH THE BID.						
PLEASE CONTACT GROVER ROSENCRANCE TWO DAYS PRIOR TO THE PRE-BID DATE TO PRE-REGISTER FOR THE PRE-BID; AT 304-335-2291.						
0001	1	LS	931-30	CAFETERIA / KITCHEN EQUIPMENT	\$ 70,520 ⁰⁰	\$ 70,520 ⁰⁰
EXHIBIT 5						
NOTICE TO PROCEED: THIS CONTRACT IS TO BE PERFORMED WITHIN 60 CALENDAR DAYS AFTER THE NOTICE TO PROCEED IS RECEIVED. UNLESS OTHERWISE SPECIFIED, THE FULLY EXECUTED PURCHASE ORDER WILL BE CONSIDERED NOTICE TO						

RECEIVED
 MAR - 7 A 10 20
 PURCHASING DIVISION
 STATE OF WV

SEE REVERSE SIDE FOR TERMS AND CONDITIONS

SIGNATURE: *Ray Sullivan* TELEPHONE: (800) 962-8618 DATE: 3-6-07

TITLE: Bid Specialist FEIN: 550585890 ADDRESS CHANGES TO BE NOTED ABOVE

WHEN RESPONDING TO RFQ, INSERT NAME AND ADDRESS IN SPACE ABOVE LABELED 'VENDOR'

**GENERAL TERMS & CONDITIONS
REQUEST FOR QUOTATION (RFQ) AND REQUEST FOR PROPOSAL (RFP)**

1. Awards will be made in the best interest of the State of West Virginia.
2. The State may accept or reject in part, or in whole, any bid.
3. All quotations are governed by the *West Virginia Code* and the *Legislative Rules* of the Purchasing Division.
4. Prior to any award, the apparent successful vendor must be properly registered with the Purchasing Division and have paid the required \$125.00 registration fee.
5. All services performed or goods delivered under State Purchase Orders/Contracts are to be continued for the term of the Purchase Order/Contract, contingent upon funds being appropriated by the Legislature or otherwise being made available. In the event funds are not appropriated or otherwise available for these services or goods, this Purchase Order/Contract becomes void and of no effect after June 30.
6. Payment may only be made after the delivery and acceptance of goods or services.
7. Interest may be paid for late payment in accordance with the *West Virginia Code*.
8. Vendor preference will be granted upon written request in accordance with the *West Virginia Code*.
9. The State of West Virginia is exempt from federal and state taxes and will not pay or reimburse such taxes.
10. The Director of Purchasing may cancel any Purchase Order/Contract upon 30 days written notice to the seller.
11. The laws of the State of West Virginia and the *Legislative Rules* of the Purchasing Division shall govern all rights and duties under the Contract, including without limitation the validity of this Purchase Order/Contract.
12. Any reference to automatic renewal is hereby deleted. The Contract may be renewed only upon mutual written agreement of the parties.
13. **BANKRUPTCY:** In the event the vendor/contractor files for bankruptcy protection, this contract is automatically null and void, and is terminated without further order.
14. **HIPAA Business Associate Addendum** - The West Virginia State Government HIPAA Business Associate Addendum (BAA), approved by the Attorney General, and available online at the Purchasing Division's web site (<http://www.state.wv.us/admin/purchase/vrc/hipaa.htm>) is hereby made part of the agreement. Provided that, the Agency meets the definition of a Covered Entity (45 CFR §160.103) and will be disclosing Protected Health Information (45 CFR §160.103) to the vendor.

INSTRUCTIONS TO BIDDERS

1. Use the quotation forms provided by the Purchasing Division.
2. **SPECIFICATIONS:** Items offered must be in compliance with the specifications. Any deviation from the specifications must be clearly indicated by the bidder. Alternates offered by the bidder as **EQUAL** to the specifications must be clearly defined. A bidder offering an alternate should attach complete specifications and literature to the bid. The Purchasing Division may waive minor deviations to specifications.
3. Complete all sections of the quotation form.
4. Unit prices shall prevail in cases of discrepancy.
5. All quotations are considered F.O.B. destination unless alternate shipping terms are clearly identified in the quotation.
6. **BID SUBMISSION:** All quotations must be delivered by the bidder to the office listed below prior to the date and time of the bid opening. Failure of the bidder to deliver the quotations on time will result in bid disqualifications.

SIGNED BID TO:

Department of Administration
Purchasing Division
2019 Washington Street East
Post Office Box 50130
Charleston, WV 25305-0130



State of West Virginia
 Department of Administration
 Purchasing Division
 2019 Washington Street East
 Post Office Box 50130
 Charleston, WV 25305-0130

Request for Quotation

RFQ NUMBER
COR61335

PAGE
2

ADDRESS CORRESPONDENCE TO ATTENTION OF
JOHN ABBOTT
304-558-2544

VENDOR

RFQ COPY
 TYPE NAME/ADDRESS HERE

Douglas Equipment
301 North Street
Bluefield, WV 24701
(304) 327-0149 1-(800) 962-8618

SHIP TO

DIVISION OF CORRECTIONS
617 LEON SULLIVAN WAY
CHARLESTON, WV
25301 304-558-8045

DATE PRINTED	TERMS OF SALE	SHIP VIA	F.O.B.	FREIGHT TERMS
02/07/2007				

BID OPENING DATE: **03/07/2007** BID OPENING TIME **01:30PM**

LINE	QUANTITY	UOP	CAT NO	ITEM NUMBER	UNIT PRICE	AMOUNT
<p>PROCEED.</p> <p>CANCELLATION: THE DIRECTOR OF PURCHASING RESERVES THE RIGHT TO CANCEL THIS CONTRACT IMMEDIATELY UPON WRITTEN NOTICE TO THE VENDOR IF THE MATERIALS OR WORKMANSHIP SUPPLIED ARE OF AN INFERIOR QUALITY OR DO NOT CONFORM WITH THE SPECIFICATIONS OF THE BID AND CONTRACT HERE IN.</p> <p>WAGE RATES: THE CONTRACTOR OR SUBCONTRACTOR SHALL PAY THE HIGHER OF THE U.S. DEPARTMENT OF LABOR MINIMUM WAGE RATES AS ESTABLISHED FOR RANDOLPH COUNTY, PURSUANT TO WEST VIRGINIA CODE 21-5A, ET, SEQ. (PREVAILING WAGE RATES APPLY TO THIS PROJECT)</p> <p>ARBITRATION: ANY REFERENCES MADE TO ARBITRATION OR INTEREST FOR PAYMENTS DUE (EXCEPT FOR ANY INTEREST REQUIRED BY STATE LAW) CONTAINED IN THIS CONTRACT OR IN ANY AMERICAN INSTITUTE OF ARCHITECTS DOCUMENTS PERTAINING TO THIS CONTRACT ARE HEREBY DELETED.</p> <p>WORKERS' COMPENSATION: VENDOR IS REQUIRED TO PROVIDE A CERTIFICATE FROM WORKERS' COMPENSATION IF SUCCESSFUL.</p> <p>ALL OF THE ITEMS CHECKED BELOW WILL BE A REQUIREMENT OF THIS CONTRACT:</p> <p>(XX) INSURANCE: SUCCESSFUL VENDOR SHALL FURNISH PROOF OF COMMERCIAL GENERAL LIABILITY INSURANCE PRIOR TO ISSUANCE OF CONTRACT. UNLESS OTHERWISE SPECIFIED IN THE BID DOCUMENTS, THE MINIMUM AMOUNT OF INSURANCE COVERAGE REQUIRED IS \$250,000.</p> <p>() BUILDERS RISK INSURANCE: SUCCESSFUL VENDOR SHALL FURNISH PROOF OF BUILDERS RISK - ALL RISK INSURANCE IN AN AMOUNT EQUAL TO 100% OF THE AMOUNT OF THE CONTRACT.</p>						

SEE REVERSE SIDE FOR TERMS AND CONDITIONS

SIGNATURE <i>Ray E. Wilson</i>	TELEPHONE <i>(800) 962 8618</i>	DATE <i>3-6-07</i>
TITLE <i>Bid Specialist</i>	FEN <i>550585890</i>	ADDRESS CHANGES TO BE NOTED ABOVE

WHEN RESPONDING TO RFQ, INSERT NAME AND ADDRESS IN SPACE ABOVE LABELED 'VENDOR'



State of West Virginia
 Department of Administration
 Purchasing Division
 2019 Washington Street East
 Post Office Box 50130
 Charleston, WV 25305-0130

Request for Quotation

RFQ NUMBER
COR61335

PAGE
3

ADDRESS CORRESPONDENCE TO ATTENTION OF
**JOHN ABBOTT
 304-558-2544**

RFQ COPY

TYPE NAME/ADDRESS HERE

**Douglas Equipment
 301 North Street
 Bluefield, WV 24701
 (304) 327-0149 1-(800) 962-8618**

SHIP TO

**DIVISION OF CORRECTIONS
 617 LEON SULLIVAN WAY
 CHARLESTON, WV
 25301 304-558-8045**

DATE PRINTED 02/07/2007	TERMS OF SALE	SHIP VIA	FOB	FREIGHT TERMS
-----------------------------------	---------------	----------	-----	---------------

BID OPENING DATE: **03/07/2007** BID OPENING TIME **01:30PM**

LINE	QUANTITY	UOP	CAT NO	ITEM NUMBER	UNIT PRICE	AMOUNT
<p>(XX) BONDS: FIVE PERCENT (5%) OF THE TOTAL AMOUNT OF THE BID PAYABLE TO THE STATE OF WEST VIRGINIA, SHALL BE SUBMITTED WITH EACH BID AS A BID BOND. THE SUCCESSFUL BIDDER SHALL ALSO FURNISH A PERFORMANCE BOND AND LABOR/MATERIAL BOND FOR 100% OF THE AMOUNT OF THE CONTRACT. BONDS MAY BE PROVIDED IN THE FORM OF A CERTIFIED CHECK, IRREVOCABLE LETTER OF CREDIT, OR BOND FURNISHED BY A SOLVENT SURETY COMPANY AUTHORIZED TO DO BUSINESS IN THE STATE OF WEST VIRGINIA. A LETTER OF CREDIT SUBMITTED IN LIEU OF A PERFORMANCE AND LABOR & MATERIAL BOND WILL ONLY BE ALLOWED FOR PROJECTS UNDER \$100,000. PERSONAL OR BUSINESS CHECKS ARE NOT ACCEPTABLE IN LIEU OF THE 5% BID BOND, PERFORMANCE BOND, OR LABOR AND MATERIAL BOND.</p> <p>() MAINTENANCE BOND: A TWO (2) YEAR MAINTENANCE BOND COVERING THE ROOFING SYSTEM WILL BE A REQUIREMENT OF THE SUCCESSFUL VENDOR.</p> <p>REV. 11/00</p> <p>EXHIBIT 7</p> <p>DOMESTIC ALUMINUM, GLASS & STEEL IN PUBLIC WORKS PROJECTS</p> <p>IN ACCORDANCE WITH WEST VIRGINIA CODE 5-19-1 ET., SEQ., EVERY CONTRACT FOR CONSTRUCTION, RECONSTRUCTION, ALTERATION, REPAIR, IMPROVEMENT OR MAINTENANCE OF PUBLIC WORKS, WHERE THE COST IS MORE THAN \$50,000 AND, IN THE CASE OF STEEL ONLY, WHERE THE COST OF STEEL IS MORE THAN \$50,000 OR WHERE MORE THAN 10,000 POUNDS OF STEEL ARE REQUIRED, THE STATE WILL ACCEPT ONLY ALUMINUM GLASS, OR STEEL PRODUCTS PRODUCED IN THE UNITED STATES</p>						

SEE REVERSE SIDE FOR TERMS AND CONDITIONS

SIGNATURE <i>Ray Ellison</i>	TELEPHONE <i>(800) 962-8618</i>	DATE <i>3-6-07</i>
TITLE <i>Bid Specialist</i>	FEIN <i>550585890</i>	ADDRESS CHANGES TO BE NOTED ABOVE

WHEN RESPONDING TO RFQ, INSERT NAME AND ADDRESS IN SPACE ABOVE LABELED 'VENDOR'



State of West Virginia
 Department of Administration
 Purchasing Division
 2019 Washington Street East
 Post Office Box 50130
 Charleston, WV 25305-0130

Request for Quotation

RFQ NUMBER
COR61335

PAGE
4

ADDRESS CORRESPONDENCE TO ATTENTION OF
JOHN ABBOTT
304-558-2544

PROPERTY

RFQ COPY
 TYPE NAME/ADDRESS HERE

Douglas Equipment
301 North Street
Bluefield, WV 24701
(304) 327-0149 1-(800) 962-8618

SHIP TO

DIVISION OF CORRECTIONS
617 LEON SULLIVAN WAY
CHARLESTON, WV
25301 304-558-8045

DATE PRINTED	TERMS OF SALE	SHIP VIA	F.O.B.	FREIGHT TERMS		
02/07/2007						
BID OPENING DATE: 03/07/2007		BID OPENING TIME 01:30PM				
LINE	QUANTITY	UOP	CAT NO	ITEM NUMBER	UNIT PRICE	AMOUNT
<p>IN ADDITION, ITEMS OF MACHINERY OR EQUIPMENT PURCHASED FOR USE AT THE SITE OF PUBLIC WORKS SHALL BE MADE OF DOMESTIC ALUMINUM, GLASS OR STEEL, UNLESS THE COST OF THE PRODUCT IS LESS THAN \$50,000 OR LESS THAN 10,000 POUNDS OF STEEL ARE USED IN PUBLIC WORKS PROJECTS.</p> <p>FOREIGN MADE ALUMINUM, GLASS OR STEEL PRODUCTS MAY BE ACCEPTED ONLY IF THE COST OF DOMESTIC PRODUCTS IS FOUND TO BE UNREASONABLE. SUCH COST IS UNREASONABLE IF IT IS 20% OR MORE HIGHER THAN THE BID PRICE FOR FOREIGN MADE PRODUCTS. IF THE DOMESTIC ALUMINUM, GLASS OR STEEL PRODUCTS TO BE SUPPLIED OR PRODUCED IN A "SUBSTANTIAL LABOR SURPLUS AREA", AS DEFINED BY THE UNITED STATES DEPARTMENT OF LABOR, FOREIGN PRODUCTS MAY BE SUPPLIED ONLY IF DOMESTIC PRODUCTS ARE 30% OR MORE HIGHER IN PRICE THAN THE FOREIGN MADE PRODUCTS.</p> <p>IF, PRIOR TO THE AWARD OF A CONTRACT UNDER THE ABOVE PROVISIONS, THE SPENDING OFFICER OF THE SPENDING UNIT DETERMINES THAT THERE EXISTS A BID FOR LIKE FOREIGN ALUMINUM, GLASS OR STEEL THAT IS REASONABLE AND LOWER THAN THE LOWEST BID DOMESTIC PRODUCTS, THE SPENDING OFFICE MAY REQUEST, IN WRITING, A REEVALUATION AND REDUCTION IN THE LOWEST BID FOR SUCH DOMESTIC PRODUCTS ALL VENDORS MUST INDICATE IN THEIR BID IF THEY ARE SUPPLYING FOREIGN ALUMINUM, GLASS OR STEEL.</p> <p>REV. 3/88</p> <p>EXHIBIT 9</p> <p>NOTICE FOR ISSUANCE & ACKNOWLEDGEMENT OF CONSTRUCTION PROJECT ADDENDA</p> <p>THE ARCHITECT/ENGINEER AND/OR AGENCY SHALL BE REQUIRED</p>						
SEE REVERSE SIDE FOR TERMS AND CONDITIONS						
SIGNATURE <i>Ray Zellner</i>			TELEPHONE (800) 962-8618		DATE 3-6-07	
TITLE Bid Specialist		FEIN 550585890		ADDRESS CHANGES TO BE NOTED ABOVE		

WHEN RESPONDING TO RFQ, INSERT NAME AND ADDRESS IN SPACE ABOVE LABELED 'VENDOR'



State of West Virginia
 Department of Administration
 Purchasing Division
 2019 Washington Street East
 Post Office Box 50130
 Charleston, WV 25305-0130

Request for Quotation

RFQ NUMBER
CDR61335

PAGE
5

ADDRESS CORRESPONDENCE TO ATTENTION OF
JOHN ABBOTT
304-558-2544

PROPERTY

RFQ COPY
 TYPE NAME/ADDRESS HERE

Douglas Equipment
301 North Street
Bluefield, WV 24701
(304) 327-0149 1-(800) 962-8618

SHIP TO

DIVISION OF CORRECTIONS
617 LEON SULLIVAN WAY
CHARLESTON, WV
25301 304-558-8045

DATE PRINTED	TERMS OF SALE	SHIP VIA	F.O.B.	FREIGHT TERMS
02/07/2007				

BID OPENING DATE: **03/07/2007** BID OPENING TIME **01:30PM**

LINE	QUANTITY	UOP	CAT NO	ITEM NUMBER	UNIT PRICE	AMOUNT
<p>TO ABIDE BY THE FOLLOWING SCHEDULE IN ISSUING CONSTRUCTION PROJECT ADDENDA FOR STATE AGENCIES:</p> <p>(1) THE ARCHITECT/ENGINEER SHALL PREPARE THE ADDENDUM AND A LIST OF ALL PARTIES THAT HAVE PROCURED DRAWINGS AND SPECIFICATIONS FOR THE PROJECT. THE ADDENDUM AND LIST SHALL BE FORWARDED TO THE BUYER IN THE STATE PURCHASING DIVISION. THE ARCHITECT/ENGINEER SHALL ALSO SEND A COPY OF THE ADDENDUM TO THE STATE AGENCY FOR WHICH THE CONTRACT IS ISSUED.</p> <p>(2) THE BUYER SHALL SEND THE ADDENDUM TO ALL INTERESTED PARTIES AND, IF NECESSARY, EXTEND THE BID OPENING DATE. ANY ADDENDUM SHOULD BE RECEIVED BY THE BUYER WITHIN FOURTEEN (14) DAYS PRIOR TO THE BID OPENING DATE.</p> <p>(3) ALL ADDENDA SHOULD BE FORMALLY ACKNOWLEDGED BY ALL BIDDERS AND SUBMITTED TO THE STATE PURCHASING DIVISION. THE SAME RULES AND REGULATIONS THAT APPLY TO THE ORIGINAL BIDDING DOCUMENT SHALL ALSO APPLY TO AN ADDENDUM DOCUMENT. THE ONLY EXCEPTION MAY BE FOR AN ADDENDUM THAT IS ISSUED FOR THE SOLE PURPOSE OF CHANGING A BID OPENING TIME AND/OR DATE.</p> <p>REV. 11/96</p> <p>EXHIBIT 10</p> <p>ADDENDUM ACKNOWLEDGEMENT</p> <p>I HEREBY ACKNOWLEDGE RECEIPT OF THE FOLLOWING CHECKED ADDENDUM(S) AND HAVE MADE THE NECESSARY REVISIONS TO MY PROPOSAL, PLANS AND/OR SPECIFICATION, ETC.</p>						

SEE REVERSE SIDE FOR TERMS AND CONDITIONS

SIGNATURE <i>Ray Sullivan</i>	TELEPHONE (800) 962-8618	DATE 3-6-07
TITLE Bid Specialist	FEIN 550585890	ADDRESS CHANGES TO BE NOTED ABOVE

WHEN RESPONDING TO RFQ, INSERT NAME AND ADDRESS IN SPACE ABOVE LABELED 'VENDOR'



State of West Virginia
 Department of Administration
 Purchasing Division
 2019 Washington Street East
 Post Office Box 50130
 Charleston, WV 25305-0130

Request for Quotation

RFQ NUMBER
CDR61335

PAGE
6

ADDRESS CORRESPONDENCE TO ATTENTION OF
JOHN ABBOTT
304-558-2544

RFQ COPY
 TYPE NAME/ADDRESS HERE

SUPPLIER

Douglas Equipment
 301 North Street
 Bluefield, WV 24701
 (304) 327-0149 1-(800) 962-8618

SUSPENSE

DIVISION OF CORRECTIONS
 617 LEON SULLIVAN WAY
 CHARLESTON, WV
 25301 304-558-8045

DATE PRINTED 02/07/2007	TERMS OF SALE	SHIP VIA	FOB	FREIGHT TERMS
BID OPENING DATE: 03/07/2007		BID OPENING TIME 01:30PM		

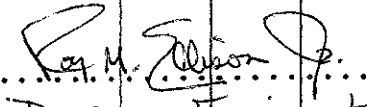
LINE	QUANTITY	UOP	CAT NO	ITEM NUMBER	UNIT PRICE	AMOUNT
ADDENDUM NOS.:						
NO. 1		✓				
NO. 3						
NO. 4						
NO. 5						
I UNDERSTAND THAT FAILURE TO CONFIRM THE RECEIPT OF THE ADDENDUM(S) MAY BE CAUSE FOR REJECTION OF THE BIDS.						
 SIGNATURE						
..... Douglas Equipment COMPANY						
..... 3/6/07 DATE						
REV. 11/96						
CONTRACTORS LICENSE						
WEST VIRGINIA STATE CODE 21-11-2 REQUIRES THAT ALL PERSONS DESIRING TO PERFORM CONTRACTING WORK IN THIS STATE MUST BE LICENSED. THE WEST VIRGINIA CONTRACTORS LICENSING BOARD IS EMPOWERED TO ISSUE THE CONTRACTORS LICENSE. APPLICATIONS FOR A CONTRACTORS LICENSE MAY BE MADE BY CONTACTING THE WEST VIRGINIA DIVISION OF LABOR CAPITOL COMPLEX, BUILDING 3, ROOM 319, CHARLESTON, WV 25305. TELEPHONE: (304) 558-7890.						

SEE REVERSE SIDE FOR TERMS AND CONDITIONS

SIGNATURE <i>Ray Ellison</i>	TELEPHONE <i>(800) 962-8618</i>	DATE <i>3-6-07</i>
TITLE <i>Bid Specialist</i>	FEIN <i>550E85890</i>	ADDRESS CHANGES TO BE NOTED ABOVE

WHEN RESPONDING TO RFQ, INSERT NAME AND ADDRESS IN SPACE ABOVE LABELED 'VENDOR'



State of West Virginia
 Department of Administration
 Purchasing Division
 2019 Washington Street East
 Post Office Box 50130
 Charleston, WV 25305-0130

Request for Quotation

RFQ NUMBER
CDR61335

PAGE
7

ADDRESS CORRESPONDENCE TO ATTENTION OF
JOHN ABBOTT
304-558-2544

RFQ COPY
 TYPE NAME/ADDRESS HERE

PROPERTY

Douglas Equipment
301 North Street
Bluefield, WV 24701
(304) 327-0149 1-(800) 962-8618

SUPPLIER

DIVISION OF CORRECTIONS
617 LEON SULLIVAN WAY
CHARLESTON, WV
25301 304-558-8045

DATE PRINTED 02/07/2007	TERMS OF SALE	SHIP VIA	FOB	FREIGHT TERMS
-----------------------------------	---------------	----------	-----	---------------

BID OPENING DATE: **03/07/2007** BID OPENING TIME **01:30PM**

LINE	QUANTITY	UOP	GAT NO.	ITEM NUMBER	UNIT PRICE	AMOUNT
<p>WEST VIRGINIA STATE CODE 21-11-11 REQUIRES ANY PROSPECTIVE BIDDER TO INCLUDE THE CONTRACTORS LICENSE NUMBER ON THEIR BID.</p> <p>BIDDER TO COMPLETE:</p> <p>CONTRACTORS NAME: <i>Douglas Equipment</i></p> <p>CONTRACTORS LICENSE NO.: <i>WV 008722</i></p> <p>THE SUCCESSFUL BIDDER WILL BE REQUIRED TO FURNISH A COPY OF THEIR CONTRACTORS LICENSE PRIOR TO ISSUANCE OF A PURCHASE ORDER/CONTRACT</p> <p style="text-align: center;">APPLICABLE LAW</p> <p>THE WEST VIRGINIA STATE CODE, PURCHASING DIVISION RULES AND REGULATIONS, AND THE INFORMATION PROVIDED IN THE "REQUEST FOR QUOTATION" ISSUED BY THE PURCHASING DIVISION IS THE SOLE AUTHORITY GOVERNING THIS PROCUREMENT.</p> <p>ANY INFORMATION PROVIDED IN SPECIFICATION MANUALS, OR ANY OTHER SOURCE, VERBAL OR WRITTEN, WHICH CONTRADICTS OR ALTERS THE INFORMATION PROVIDED FROM THE SOURCES AS DESCRIBED IN THE ABOVE PARAGRAPH IS VOID AND OF NO EFFECT.</p> <p>BANKRUPTCY: IN THE EVENT THE VENDOR/CONTRACTOR FILES FOR BANKRUPTCY PROTECTION, THIS CONTRACT IS AUTOMATICALLY NULL AND VOID, AND IS TERMINATED WITHOUT FURTHER ORDER.</p> <p>REV. 1/2005</p>						

SEE REVERSE SIDE FOR TERMS AND CONDITIONS

SIGNATURE <i>Ray Zellion</i>	TELEPHONE <i>(800) 962-8618</i>	DATE <i>3-6-07</i>
TITLE <i>Bid Specialist</i>	FEIN <i>550585890</i>	ADDRESS CHANGES TO BE NOTED ABOVE

WHEN RESPONDING TO RFQ, INSERT NAME AND ADDRESS IN SPACE ABOVE LABELED 'VENDOR'



State of West Virginia
 Department of Administration
 Purchasing Division
 2019 Washington Street East
 Post Office Box 50130
 Charleston, WV 25305-0130

Request for Quotation

RFQ NUMBER:
COR61335

PAGE:
8

ADDRESS CORRESPONDENCE TO ATTENTION OF:
**JOHN ABBOTT
 304-558-2544**

RFQ COPY
 TYPE NAME/ADDRESS HERE

VENDOR

**Douglas Equipment
 301 North Street
 Bluefield, WV 24701
 (304) 327-0149 1-(800) 962-8618**

SHIP TO

**DIVISION OF CORRECTIONS
 617 LEON SULLIVAN WAY
 CHARLESTON, WV
 25301 304-558-8045**

DATE PRINTED	TERMS OF SALE	SHIP VIA	F.O.B.	FREIGHT TERMS
02/07/2007				

BID OPENING DATE: **03/07/2007** BID OPENING TIME **01:30PM**

LINE	QUANTITY	UOP	CAT. NO.	ITEM NUMBER	UNIT PRICE	AMOUNT
NOTICE						
A SIGNED BID MUST BE SUBMITTED TO:						
DEPARTMENT OF ADMINISTRATION PURCHASING DIVISION BUILDING 15 2019 WASHINGTON STREET, EAST CHARLESTON, WV 25305-0130						
THE BID SHOULD CONTAIN THIS INFORMATION ON THE FACE OF THE ENVELOPE OR THE BID MAY NOT BE CONSIDERED:						
SEALED BID						
BUYER: JOHN ABBOTT-----						
REQ. NO.: COR61335-----						
BID OPENING DATE: 3/7/2007-----						
BID OPENING TIME: 1:30 PM-----						
PLEASE PROVIDE A FAX NUMBER IN CASE IT IS NECESSARY TO CONTACT YOU REGARDING YOUR BID:						
(304) 325-3818-----						
PLEASE PRINT OR TYPE NAME OF PERSON TO CONTACT CONCERNING THIS QUOTE:						
Roy Ellison-----						

SEE REVERSE SIDE FOR TERMS AND CONDITIONS

SIGNATURE <i>Roy Ellison</i>	TELEPHONE (800)962-8618	DATE 3-6-07
TITLE Bid Specialist	FEIN 550585890	ADDRESS CHANGES TO BE NOTED ABOVE

WHEN RESPONDING TO RFQ, INSERT NAME AND ADDRESS IN SPACE ABOVE LABELED 'VENDOR'



State of West Virginia
 Department of Administration
 Purchasing Division
 2019 Washington Street East
 Post Office Box 50130
 Charleston, WV 25305-0130

Request for Quotation

RFQ NUMBER
COR61335

PAGE
9

ADDRESS CORRESPONDENCE TO ATTENTION OF:
JOHN ABBOTT
304-558-2544

VENDOR

RFQ COPY
 TYPE NAME/ADDRESS HERE

Douglas Equipment
301 North Street
Bluefield, WV 24701
(304) 327-0149 1-(800) 962-8618

SHIP TO

DIVISION OF CORRECTIONS
617 LEON SULLIVAN WAY
CHARLESTON, WV
25301 304-558-8045

DATE PRINTED	TERMS OF SALE	SHIP VIA	FOB	FREIGHT TERMS
02/07/2007				

BID OPENING DATE: **03/07/2007** BID OPENING TIME **01:30PM**

LINE	QUANTITY	UOP	CAT NO	ITEM NUMBER	UNIT PRICE	AMOUNT
***** THIS IS THE END OF RFQ COR61335 ***** TOTAL:						<u>\$70,520⁰⁰</u>

SEE REVERSE SIDE FOR TERMS AND CONDITIONS

SIGNATURE Ray Sullivan TELEPHONE (800) 962-8618 DATE 3-6-07
 TITLE Bid Specialist FEIN 550585890 ADDRESS CHANGES TO BE NOTED ABOVE

WHEN RESPONDING TO RFQ, INSERT NAME AND ADDRESS IN SPACE ABOVE LABELED 'VENDOR'

STATE OF WEST VIRGINIA
PURCHASE CONTINUATION SHEET

Buyer:	Page:	Requisition or P. O. No.:
32	10	COR61335
Spending Unit:		

Vendor: _____

<u>Item</u>	<u>Quantity</u>	<u>Description</u>	<u>Cost</u>
1	2 each	HEATED CABINET, MOBILE Food Warming Equipment Model No. PST-20 or equal Heated cabinet, mobile, double comp't, insulated, top mounted circulating heat system w/recessed controls, s/s fixed pan slides 2.5" OC, (20) 12x20x2.5 in./Gastro-Norm pans, s/s const'n, H.D. push bars, full bumper, 5" poly casters.	
	2	Two year limited parts & one-year labor warranty, standard.	
	2	20v/50-60/1ph, std.	
	2	LEVEL 2 - Security: thermostat capillary guard, plexiguard thermometer cvr, thermostat retention strap, paddle latch, s/s HD hinges, tamper proof screws, top "MaxiGuard" or dr "Maxi-Slide", S/s tubular hdls, 18 ga. ext'r/20ga int'r	
2	1 each	PEELER, VEGETABLE, ELECTRIC Hobart Model No. 6460c+BUILDUP or Equal Vegetable Peeler, Correctional, 50-60 lb. Potatoes in 1-3 minute cap., V-belt drive, removable, abrasive silicon carbide disc and lexan liner, welded s/s construction, lockable controls, tamper resistant fasteners, 1 hp.	
	1	1-Year parts, labor & travel time during normal working hours w/in theUSA.	
	1	6460C-ELE00E 200-230/60/1	
	1	6460C-SWIT04 4 minute timer switch 1 ph only	
	1	6460C-SWPORH Switch on RH side	
	1	6460C-LOCYES W/lockable controls	
	1	6460C-CBTSST Cabinet, base and trap - s/s strainer	
3	1 each	GRIDDLE, COUNTER UNIT, ELECTRIC Hobart Model No. CG59-1 or Equal Griddle, Counter Unit, Elec., 72"w x 24"d x 1/2" thick smooth polished steel griddle plate, thermostats @ 12" zones, s/s heating elements, front grease trough, 3" h back splash, s/s exterior, 208/60/1 or 3 ph, 16.2 kw per connection (2)	
	1	1 - Year parts, labor & travel time during normal working hours.	
	1	STAND/L-CG59 Griddle stands w/legs 72" wide	

**STATE OF WEST VIRGINIA
PURCHASE CONTINUATION SHEET**

Buyer:	Page:	Requisition or P.O. No.:
32	11	COR61335
Spending Unit:		

Vendor: _____

4	2 each	<p>CONVECTION OVEN, ELECTRIC Hobart Model No. HEC502-208V or Equal Convection Oven, Elec., double-deck, std. Depth, 500 F solid state temp. cont'l, 60 minute timers, 2-speed fans, s/s front, top & sides, porcelain interior, s/s simultaneous doors w/glass, 8" s/s legs, 208v/60/1 or 3 ph, 12 kw each. PRICE TO INCLUDE CORRECTIONAL PACKAGE FOR EACH DOUBLE STACK-</p>
	2	1-Year parts, labor & travel time during normal working hours
5	1 each	<p>STEAMER, PRESSURE, DIRECT STEAM Southbend Model No. DC-3S or Equal Steamer, Pressure-Type, Direct, 3 compartments, 36" cabinet base, manual timer controls, s/s interior & exterior</p>
	1	115/60/1-ph, std.
	1	35 PSI std,
	1	Standard one year limited warranty
	1	Cabinet base doors w/locking provisions
	1	Correctional screws & tack welds
6	1 each	<p>TILTING KETTLE, DIRECT STEAM Southbend Model NO. KDL-100 or Equal Tilting Kettle, Direct, 100-gal cap., two-thirds jacket, s/s interior & exterior, s/s console w/crank tilt w/self-locking positive stop, s/s tri-leg base, 35 PSI</p>
	1	Standard one year limited warranty
	1	TVT-3 3" tangent draw off valve added to tilting kettle
	1	Correctional screws & tack welds where applicable
	1	s/s cover over control panel w/locking provisions
7	2 each	<p>FRYER, ELECTRIC Hobart Model No. 1HF85C-3 or Equal Fryer, Electric, 85 lbs., computer controls, melt cycle, single autobasket lift, s/s tank with 1 1/2" full port drain valve, s/s front & sides, 208/60/3, 24KW heating element, filter ready, on 4" legs</p>
	2	HBASKET-TWIN85 Twin Baskets HF85
	1	GRSTRIP-SPERH Banking strips
8	1 each	<p>MOBILE FILTER Hobart Model No. 85HMF-5 or Equal Mobile Filter, 100 lbs. Capacity, 208/60/1 NOTE: Please confirm voltage and basket quantity.</p>

RFQ No. COR61335

A F F I D A V I T

West Virginia Code §5A-3-10a states:

No contract or renewal of any contract may be awarded by the state or any of its political subdivisions to any vendor or prospective vendor when the vendor or prospective vendor or a related party to the vendor or prospective vendor is a debtor and the debt owned is an amount greater than one thousand dollars in the aggregate

DEFINITIONS:

"Debt" means any assessment, premium, penalty, fine, tax or other amount of money owed to the state or any of its political subdivisions because of a judgment, fine, permit violation, license assessment, defaulted workers' compensation premium, penalty or other assessment presently delinquent or due and required to be paid to the state or any of its political subdivisions, including any interest or additional penalties accrued thereon.

"Debtor" means any individual, corporation, partnership, association, limited liability company or any other form or business association owing a debt to the state or any of its political subdivisions. "Political subdivision" means any county commission; municipality; county board of education; any instrumentality established by a county or municipality; any separate corporation or instrumentality established by one or more counties or municipalities, as permitted by law; or any public body charged by law with the performance of a government function or whose jurisdiction is coextensive with one or more counties or municipalities. "Related party" means a party, whether an individual, corporation, partnership, association, limited liability company or any other form or business association or other entity whatsoever, related to any vendor by blood, marriage, ownership or contract through which the party has a relationship of ownership or other interest with the vendor so that the party will actually or by effect receive or control a portion of the benefit, profit or other consideration from performance of a vendor contract with the party receiving an amount that meets or exceeds five percent of the total contract amount

EXCEPTION:

The prohibition of this section does not apply where a vendor has contested any tax administered pursuant to chapter eleven of this code, workers' compensation premium, permit fee or environmental fee or assessment and the matter has not become final or where the vendor has entered into a payment plan or agreement and the vendor is not in default of any of the provisions of such plan or agreement.

LICENSING:

Vendors must be licensed and in good standing in accordance with any and all state and local laws and requirements by any state or local agency of West Virginia, including, but not limited to, the West Virginia Secretary of State's Office, the West Virginia Tax Department, West Virginia Insurance Commission, or any other state agencies or political subdivision. Furthermore, the vendor must provide all necessary releases to obtain information to enable the Director or spending unit to verify that the vendor is licensed and in good standing with the above entities.

CONFIDENTIALITY:

The vendor agrees that he or she will not disclose to anyone, directly or indirectly, any such personally identifiable information or other confidential information gained from the agency, unless the individual who is the subject of the information consents to the disclosure in writing or the disclosure is made pursuant to the agency's policies, procedures and rules. Vendors should visit www.state.wv.us/admin/purchase/privacy for the Notice of Agency Confidentiality Policies

Under penalty of law for false swearing (West Virginia Code, §61-5-3), it is hereby certified that the vendor acknowledges the information in this said affidavit and are in compliance with the requirements as stated.

Vendor's Name: DOUGLAS EQUIPMENT

Authorized Signature:  Date: 3-6-07



State of West Virginia
 Department of Administration
 Purchasing Division
 2019 Washington Street East
 Post Office Box 50130
 Charleston, WV 25305-0130

Request for Quotation

RFQ NUMBER
COR61335

PAGE
1

ADDRESS CORRESPONDENCE TO ATTENTION OF
JOHN ABBOTT
304-558-2544

RFQ COPY
 TYPE NAME/ADDRESS HERE

VENDOR

Douglas Equipment
301 North Street
Bluefield, WV 24701
(304) 327-0149 1-(800) 962-8618

SHIP TO

DIVISION OF CORRECTIONS
617 LEON SULLIVAN WAY
CHARLESTON, WV
25301 304-558-8045

DATE PRINTED 02/14/2007	TERMS OF SALE	SHIP VIA	F.O.B.	FREIGHT TERMS
-----------------------------------	---------------	----------	--------	---------------

BID OPENING DATE: **03/07/2007** BID OPENING TIME: **01:30PM**

LINE	QUANTITY	UOP	CAT NO.	ITEM NUMBER	UNIT PRICE	AMOUNT
				ADDENDUM #01		
				<p>THIS ADDENDUM IS ISSUED TO CANCEL THE PRE-BID MEETING TO BE HELD ON 2/23/2007. THE REASON FOR THE CANCELLATION IS THAT THE KITCHEN AREA IS CURRENTLY UNDER RENOVATION AND NOT AVAILABLE FOR INSPECTION.</p> <p>SUCCESSFUL BIDDER WILL DELIVER, UN-CRATE, ASSEMBLE, SET IN PLACE AND ANCHOR TO THE FLOOR - ALL CONNECTIONS WILL BE COMPLETED AT A LATER TIME BY CORRECTION'S STAFF</p> <p>DUE TO CURRENT RENOVATIONS AND EXACT UNKNOWN DATE OF COMPLETION, VENDOR WILL DELIVER UPON NOTIFICATION OF GROVER ROSENCRANCE, ASSOCIATE WARDEN. PLEASE LIST POINT OF CONTACT WITH PHONE NUMBER(S). ANTICIPATED RENOVATION COMPLETION DATE IS 5/15/2007.</p>		
				<p><i>Point of Contact</i></p> <p><i>Roy Ellison - Bid Specialist (Ext. 22A)</i> <i>(800) 962-8618</i> <i>(304) 327-0149</i> <i>(304) 325-3848 fax</i> <i>roy@douglasequipment.us</i></p>		

SEE REVERSE SIDE FOR TERMS AND CONDITIONS

SIGNATURE <i>Roy Ellison</i>	TELEPHONE <i>(800) 962-8618</i>	DATE <i>3-6-07</i>
TITLE <i>Bid Specialist</i>	FEIN <i>550585890</i>	ADDRESS CHANGES TO BE NOTED ABOVE

WHEN RESPONDING TO RFQ, INSERT NAME AND ADDRESS IN SPACE ABOVE LABELED 'VENDOR'

**GENERAL TERMS & CONDITIONS
REQUEST FOR QUOTATION (RFQ) AND REQUEST FOR PROPOSAL (RFP)**

- 1 Awards will be made in the best interest of the State of West Virginia
- 2 The State may accept or reject in part, or in whole, any bid
- 3 All quotations are governed by the *West Virginia Code* and the *Legislative Rules* of the Purchasing Division
- 4 Prior to any award, the apparent successful vendor must be properly registered with the Purchasing Division and have paid the required \$125.00 registration fee.
- 5 All services performed or goods delivered under State Purchase Orders/Contracts are to be continued for the term of the Purchase Order/Contract, contingent upon funds being appropriated by the Legislature or otherwise being made available. In the event funds are not appropriated or otherwise available for these services or goods, this Purchase Order/Contract becomes void and of no effect after June 30.
- 6 Payment may only be made after the delivery and acceptance of goods or services.
- 7 Interest may be paid for late payment in accordance with the *West Virginia Code*.
- 8 Vendor preference will be granted upon written request in accordance with the *West Virginia Code*.
- 9 The State of West Virginia is exempt from federal and state taxes and will not pay or reimburse such taxes.
- 10 The Director of Purchasing may cancel any Purchase Order/Contract upon 30 days written notice to the seller.
- 11 The laws of the State of West Virginia and the *Legislative Rules* of the Purchasing Division shall govern all rights and duties under the Contract, including without limitation the validity of this Purchase Order/Contract.
- 12 Any reference to automatic renewal is hereby deleted. The Contract may be renewed only upon mutual written agreement of the parties.
- 13 **BANKRUPTCY:** In the event the vendor/contractor files for bankruptcy protection, this contract is automatically null and void, and is terminated without further order.
- 14 **HIPAA Business Associate Addendum -** The West Virginia State Government HIPAA Business Associate Addendum (BAA), approved by the Attorney General, and available online at the Purchasing Division's web site (<http://www.state.wv.us/admin/purchase/vrc/hipaa.htm>) is hereby made part of the agreement. Provided that, the Agency meets the definition of a Covered Entity (45 CFR §160.103) and will be disclosing Protected Health Information (45 CFR §160.103) to the vendor.

INSTRUCTIONS TO BIDDERS

- 1 Use the quotation forms provided by the Purchasing Division.
- 2 **SPECIFICATIONS:** Items offered must be in compliance with the specifications. Any deviation from the specifications must be clearly indicated by the bidder. Alternates offered by the bidder as **EQUAL** to the specifications must be clearly defined. A bidder offering an alternate should attach complete specifications and literature to the bid. The Purchasing Division may waive minor deviations to specifications.
- 3 Complete all sections of the quotation form.
- 4 Unit prices shall prevail in cases of discrepancy.
- 5 All quotations are considered **F O B** destination unless alternate shipping terms are clearly identified in the quotation.
- 6 **BID SUBMISSION:** All quotations must be delivered by the bidder to the office listed below prior to the date and time of the bid opening. Failure of the bidder to deliver the quotations on time will result in bid disqualifications.

SIGNED BID TO:

Department of Administration
Purchasing Division
2019 Washington Street East
Post Office Box 50130
Charleston, WV 25305-0130

STATE OF WEST VIRGINIA VENDOR PREFERENCE CERTIFICATE

Certification and application* is hereby made for Preference in accordance with West Virginia Code, §5A-3-37. (Does not apply to construction contracts)

West Virginia Code, §5A-3-37, provides an opportunity for qualifying vendors to request (at the time of bid) preference for their residency status. Such preference is an evaluation method only and will be applied only to the cost bid in accordance with the **West Virginia Code**. This certificate for application is to be used to request such preference. The Purchasing Division will make the determination of the Resident Vendor Preference, if applicable.

A. Application is made for 2.5% preference for the reason checked:

- Bidder is an individual resident vendor and has resided continuously in West Virginia for four (4) years immediately preceding the date of this certification;
- or
- Bidder is a partnership, association or corporation resident vendor and has maintained its headquarters or principal place of business continuously in West Virginia for four (4) years immediately preceding the date of this certification; or 80% of the ownership interest of Bidder is held by another individual, partnership, association or corporation resident vendor who has maintained its headquarters or principal place of business continuously in West Virginia for four (4) years immediately preceding the date of this certification;
- or
- Bidder is a nonresident vendor which has an affiliate or subsidiary which employs a minimum of one hundred state residents and which has maintained its headquarters or principal place of business within West Virginia continuously for the four (4) years immediately preceding the date of this certification.

B. Application is made for 2.5% preference for the reason checked:

- Bidder is a resident vendor who certifies that, during the life of the contract, on average at least 75% of the employees working on the project being bid are residents of West Virginia who have resided in the state continuously for the two years immediately preceding submission of this bid;
- or
- Bidder is a nonresident vendor employing a minimum of one hundred state residents or is a nonresident vendor with an affiliate or subsidiary which maintains its headquarters or principal place of business within West Virginia employing a minimum of one hundred state residents who certifies that, during the life of the contract, on average at least 75% of the employees or Bidder's affiliate's or subsidiary's employees are residents of West Virginia who have resided in the state continuously for the two years immediately preceding submission of this bid.

Bidder understands if the Secretary of Tax & Revenue determines that a Bidder receiving preference has failed to continue to meet the requirements for such preference, the Secretary may order the Director of Purchasing to: (a) rescind the contract or purchase order issued; or (b) assess a penalty against such Bidder in an amount not to exceed 5% of the bid amount and that such penalty will be paid to the contracting agency or deducted from any unpaid balance on the contract or purchase order.

By submission of this certificate, Bidder agrees to disclose any reasonably requested information to the Purchasing Division and authorizes the Department of Tax & Revenue to disclose to the Director of Purchasing appropriate information verifying that Bidder has paid the required business taxes, provided that such information does not contain the amounts of taxes paid nor any other information deemed by the Tax Commissioner to be confidential.

Under penalty of law for false swearing (West Virginia Code, §61-5-3), Bidder hereby certifies that this certificate is true and accurate in all respects; and that if a contract is issued to Bidder and if anything contained within this certificate changes during the term of the contract, Bidder will notify the Purchasing Division in writing immediately.

Bidder: DOUGLAS EQUIPMENT
Date: 3-6-07

Signed: [Signature]
Title: BID SPECIALIST

*Check any combination of preference consideration(s) in either "A" or "B", or both "A" and "B" which you are entitled to receive. You may request up to the maximum of 5% preference for both "A" and "B".

BID BOND

KNOW ALL MEN BY THESE PRESENTS, That we, the undersigned, Douglas Food Stores, Inc. DBA Douglas Equipment
of 301 North Street, Bluefield, WV 24701, as Principal, and Contractors Bonding and Insurance
Company of 1213 Valley Street, Seattle, WA, a corporation organized and existing under the laws of the State of WV
with its principal office in the City of Seattle, WA, as Surety, are held and firmly bound unto the State
of West Virginia, as Obligee, in the penal sum of 5% of Bid Amount (\$ 5% of Bid Amount) for the payment of which
well and truly to be made, we jointly and severally bind ourselves, our heirs, administrators, executors, successors and assigns

The Condition of the above obligation is such that whereas the Principal has submitted to the Purchasing Section of the
Department of Administration a certain bid or proposal, attached hereto and made a part hereof, to enter into a contract in writing for
Job/Bid No. RFQ COR61335 - Delivery and assembly of various pieces of kitchen equipment
at Huttonsville Correctional Center, Huttonsville, WV

NOW THEREFORE,

- (a) If said bid shall be rejected, or
- (b) If said bid shall be accepted and the Principal shall enter into a contract in accordance with the bid or proposal attached
hereto and shall furnish any other bonds and insurance required by the bid or proposal, and shall in all other respects perform the
agreement created by the acceptance of said bid, then this obligation shall be null and void, otherwise this obligation shall remain in full
force and effect. It is expressly understood and agreed that the liability of the Surety for any and all claims hereunder shall, in no event,
exceed the penal amount of this obligation as herein stated

The Surety, for the value received, hereby stipulates and agrees that the obligations of said Surety and its bond shall be in no
way impaired or affected by any extension of the time within which the Obligee may accept such bid, and said Surety does hereby
waive notice of any such extension

IN WITNESS WHEREOF, Principal and Surety have hereunto set their hands and seals, and such of them as are corporations
have caused their corporate seals to be affixed hereunto and these presents to be signed by their proper officers, this
6th day of March, 20 07

Principal Corporate Seal

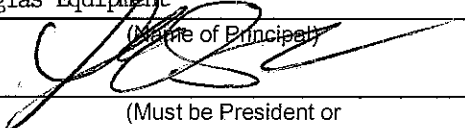
Douglas Food Stores, Inc. DBA
Douglas Equipment
(Name of Principal)
By 
(Must be President or
Vice President)
president
(Title)

Surety Corporate Seal

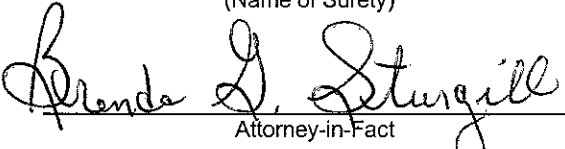
Contractors Bonding and Insurance Company
(Name of Surety)

Attorney-in-Fact

**IMPORTANT - Surety executing bonds must be licensed in West Virginia to transact surety insurance. Raised corporate seals
must be affixed, a power of attorney must be attached.**

LIMITED POWER OF ATTORNEY - READ CAREFULLY

CONTRACTORS BONDING AND INSURANCE COMPANY IS RESPONSIBLE ONLY FOR THE BOND DESCRIBED AND UP TO THE AMOUNT SET FORTH IN THIS LIMITED POWER OF ATTORNEY. ANY ERASURE WILL VOID THIS POWER OF ATTORNEY. IF YOU HAVE ANY QUESTIONS ABOUT OR WANT TO VERIFY THIS POWER OF ATTORNEY CALL CONTRACTORS BONDING AND INSURANCE COMPANY TOLL FREE AT 1(800)765-2242

Penal Sum : \$ 3,526.00 Attorney No : WV059 Power Number : E04698 Bond No : BID

Limited Power of Attorney Expires: 6/06/2007 Date Approved : 3/06/2007

Approved by : [Signature] Don Sirkin (Print Name)

Name of Principal: DOUGLAS FOOD STORES, INC. DBA DOUGLAS EQUIPMENT

Name of Oblige: STATE OF WEST VIRGINIA

Descriptions(s): JOB/BID NO. RFO COR61335 - DELIVERY AND ASSEMBLY OF VARIOUS PIECES OF KITCHEN EQUIPMENT AT HUTTONSVILLE CORRECTIONAL CENTER

Location (if applicable): HUTTONSVILLE, WEST VIRGINIA

KNOW ALL MEN BY THESE PRESENTS that CONTRACTORS BONDING AND INSURANCE COMPANY, a corporation duly organized and existing under the laws of the State of Washington and having its principal office in Seattle, King County, Washington does by these presents make, constitute and appoint BRENDA G. STURGILL OF PRINCETON, WV its true and lawful Attorney-in-Fact, with full power and authority hereby conferred in its name, place and stead, to execute, acknowledge and deliver the bond(s) and/or other documents incidental thereto described above; and to bind the Company thereby as fully and to the same extent as if each such bond, or other documents incidental thereto was signed by the President, sealed with the corporate seal of the Company and duly attested by its Secretary; hereby ratifying and confirming all that the said Attorney-In-Fact may do in the premises. Said appointment is made under and by the authority of the following resolutions adopted by the Board of Directors of CONTRACTORS BONDING AND INSURANCE COMPANY on September 10, 2001.

RESOLVED that the Chief Executive Officer, President, Chief Financial Officer, Secretary or any Vice President of the Company is authorized to appoint Attorneys-In-Fact for and on behalf of the Company with the power and authority to sign on behalf of the Company those surety bonds or undertakings of suretyship which may from time to time be approved by the Chief Executive Officer, President, Chief Financial Officer, Secretary or any Vice President of the Company; provided, however, that no Attorney-In-Fact shall be authorized to execute and deliver any bond or undertaking that shall obligate the Company for any portion of the penal sum thereof in excess of \$15,000,000, and provided, further, that no Attorney-In-Fact shall have the authority to issue a bid or proposal bond for any project where, if the contract is awarded, any bond or undertaking would be required with a penal sum in excess of \$15,000,000. An Attorney-In-Fact may also be authorized by Power of Attorney to execute any consent or other document incidental to said bond or undertaking, provided such document does not obligate the Company in excess of the limit set forth above. In no event shall any Attorney-In-Fact have any authority to sign any document or otherwise bind the Company in any way in connection with a claim on a surety bond or undertaking.

RESOLVED FURTHER that each Power of Attorney must set forth the specific description of the surety bond or undertaking to which it applies, the name of the principal, the name of the obligee, the penal sum, the bond number (except for a bid bond where there is no number), the identifying number of the Attorney-In-Fact, and the identifying number of the Power of Attorney. The Attorney-In-Fact shall not be authorized to obligate Company for surety bond or undertaking specified in the Power of Attorney (including any consents or other documents incidental to the surety bond or undertaking) for more than the penal sum specified in the Power of Attorney.

RESOLVED FURTHER that the Chief Executive Officer, President, Chief Financial Officer, Secretary or any Vice President of the Company is authorized to establish a specific expiration date for the Power of Attorney and to modify that date from time to time as the Chief Executive Officer, President, Chief Financial Officer, Secretary or any Vice President of the Company deems necessary in his/her sole discretion; the applicable expiration date is to be clearly set forth in any written Power of Attorney.

RESOLVED FURTHER that all previous resolutions by the Board of Directors authorizing the Chief Executive Officer, President, Chief Financial Officer, Secretary or any Vice President of the Company to appoint Attorneys-In-Fact for and on behalf of the Company remain in full force and effect; and that if a Power of Attorney based on this resolution is attached to a bond (for example, a bid bond), and a Power of Attorney based on another Board of Directors resolution is attached to another bond (for example, a performance and payment bond), it shall not affect the validity of either Power of Attorney or Bond.

RESOLVED FURTHER that this Limited Power of Attorney containing this and the foregoing resolutions and the signatures of the President, Secretary, and Notary Public, and the corporate and Notary seals appearing hereon, are generated, stored and transmitted electronically, and therefore appear in printed form only at recipient's fax machine. This fax printed Limited Power of Attorney document and the signatures and seals appearing hereon therefore are, and shall be deemed originals in all respects.

RESOLVED FURTHER that the Company acknowledges the applicability of the Electronic Signatures in Global and National Commerce Act to this Limited Power of Attorney and that the signatures of the President, Secretary and Notary Public and the corporate and Notary seals appearing on any Limited Power of Attorney containing this and the foregoing resolutions as well as the Limited Power of Attorney itself and its transmission may be, or may be by facsimile or other means of electronic or electro-mechanical transmission or reproduction; and any such Limited Power of Attorney shall be deemed an original in all respects.

IN WITNESS WHEREOF CONTRACTORS BONDING AND INSURANCE COMPANY has caused these presents to be signed by Don Sirkin and its corporate seal to be hereto affixed 9/9/2002.

[Signature]

CONTRACTORS BONDING AND INSURANCE COMPANY



By: Don Sirkin, President

STATE OF WASHINGTON - COUNTY OF KING

On 9/9/2002, personally appeared DON SIRKIN to me known to be the representative of the corporation that executed the foregoing Limited Power of Attorney and acknowledged said Limited Power of Attorney to be free and voluntary act and deed of said corporation, for the uses and purposes therein mentioned, and on oath stated that he is authorized to execute the said Limited Power of Attorney.

IN WITNESS WHEREOF, I have hereunto set my hand and affixed my official seal the day and year first above written.



[Signature]

Notary Public in and for the State of Washington, residing at Seattle

The undersigned acting under authority of the Board of Directors of CONTRACTORS BONDING AND INSURANCE COMPANY, hereby certifies, as or in lieu of Certificate of the Secretary of CONTRACTORS BONDING AND INSURANCE COMPANY, that the above and foregoing is a full, true and correct copy of the Original Power of Attorney issued by said Company, and does hereby further certify that the said Power of Attorney is still in force and effect GIVEN under my hand at Davidson NC this 06 day of MAR 2007

[Signature] R Kirk Eland, Secretary

ACORD CERTIFICATE OF LIABILITY INSURANCE

OP ID BW
DOUF001

DATE (MM/DD/YYYY)
03/06/07

PRODUCER Murphy Insurance Agency, Inc. 1330 Mercer St., P O Box 5069 Princeton WV 24740 Phone: 304-425-8793 Fax: 304-425-4083		THIS CERTIFICATE IS ISSUED AS A MATTER OF INFORMATION ONLY AND CONFERS NO RIGHTS UPON THE CERTIFICATE HOLDER. THIS CERTIFICATE DOES NOT AMEND, EXTEND OR ALTER THE COVERAGE AFFORDED BY THE POLICIES BELOW.	
INSURED Douglas Food Stores, Inc. dba Douglas Equipment, Super Clean Coin Laundry A-1 Leasing Laurence & Patricia Douglas 301 North Street Bluefield WV 24701		INSURERS AFFORDING COVERAGE	NAIC # 25127
		INSURER A: State Auto Insurance Companies	
		INSURER B:	
		INSURER C:	
		INSURER D:	
		INSURER E:	

COVERAGES

THE POLICIES OF INSURANCE LISTED BELOW HAVE BEEN ISSUED TO THE INSURED NAMED ABOVE FOR THE POLICY PERIOD INDICATED. NOTWITHSTANDING ANY REQUIREMENT, TERM OR CONDITION OF ANY CONTRACT OR OTHER DOCUMENT WITH RESPECT TO WHICH THIS CERTIFICATE MAY BE ISSUED OR MAY PERTAIN, THE INSURANCE AFFORDED BY THE POLICIES DESCRIBED HEREIN IS SUBJECT TO ALL THE TERMS EXCLUSIONS AND CONDITIONS OF SUCH POLICIES. AGGREGATE LIMITS SHOWN MAY HAVE BEEN REDUCED BY PAID CLAIMS

INSR ADD'L LTR INSRD	TYPE OF INSURANCE	POLICY NUMBER	POLICY EFFECTIVE DATE (MM/DD/YY)	POLICY EXPIRATION DATE (MM/DD/YY)	LIMITS
A	GENERAL LIABILITY <input checked="" type="checkbox"/> COMMERCIAL GENERAL LIABILITY <input type="checkbox"/> CLAIMS MADE <input checked="" type="checkbox"/> OCCUR GENL AGGREGATE LIMIT APPLIES PER: <input checked="" type="checkbox"/> POLICY <input type="checkbox"/> PRO-JECT <input type="checkbox"/> LOC	PBP9581467 08	03/20/07	03/20/08	EACH OCCURRENCE \$ 1000000 DAMAGE TO RENTED PREMISES (Ea occurrence) \$ 100000 MED EXP (Any one person) \$ 5000 PERSONAL & ADV INJURY \$ 1000000 GENERAL AGGREGATE \$ 2000000 PRODUCTS - COMP/OP AGG \$ 2000000
A	AUTOMOBILE LIABILITY <input type="checkbox"/> ANY AUTO <input type="checkbox"/> ALL OWNED AUTOS <input checked="" type="checkbox"/> SCHEDULED AUTOS <input checked="" type="checkbox"/> HIRED AUTOS <input checked="" type="checkbox"/> NON-OWNED AUTOS <input checked="" type="checkbox"/> Drive Other Car	BAP 9581468 08	03/20/07	03/20/08	COMBINED SINGLE LIMIT (Ea accident) \$ 1000000 BODILY INJURY (Per person) \$ BODILY INJURY (Per accident) \$ PROPERTY DAMAGE (Per accident) \$
	GARAGE LIABILITY <input type="checkbox"/> ANY AUTO				AUTO ONLY - EA ACCIDENT \$ OTHER THAN EA ACC \$ AUTO ONLY: AGG \$
A	EXCESS/UMBRELLA LIABILITY <input checked="" type="checkbox"/> OCCUR <input type="checkbox"/> CLAIMS MADE <input type="checkbox"/> DEDUCTIBLE <input checked="" type="checkbox"/> RETENTION \$ 0	PBP9581467 08	03/20/07	03/20/08	EACH OCCURRENCE \$ 2000000 AGGREGATE \$ 2000000 \$ \$ \$
A	WORKERS COMPENSATION AND EMPLOYERS' LIABILITY ANY PROPRIETOR/PARTNER/EXECUTIVE OFFICER/MEMBER EXCLUDED? If yes, describe under SPECIAL PROVISIONS below	PBP 9581467 08 EMPLOYERS LIABILITY ONLY	03/20/07	03/20/08	<input type="checkbox"/> WC STATU-TORY LIMITS <input checked="" type="checkbox"/> OTH-ER E.L. EACH ACCIDENT \$ 1000000 E.L. DISEASE - EA EMPLOYEE \$ 1000000 E.L. DISEASE - POLICY LIMIT \$ 1000000
	OTHER				

DESCRIPTION OF OPERATIONS / LOCATIONS / VEHICLES / EXCLUSIONS ADDED BY ENDORSEMENT / SPECIAL PROVISIONS
 Office Equipment Fixture or Supplies - For Bars, Hotels, Offices, Restaurants or Stores

JOB/BID NO. RFQ COR61335 - Delivery and assembly of various pieces of kitchen equipment at Huttonsville Correctional Center, Huttonsville, WV

CERTIFICATE HOLDER

CANCELLATION

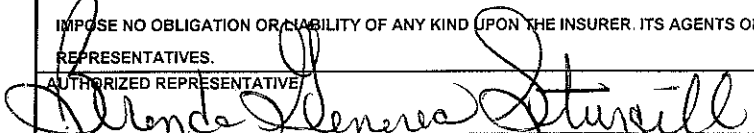
State of WV, Dept. of Admin. Purchasing Division 2019 Washington Street East PO Box 50130 Charleston WV 25301-0130	DEPA001 SHOULD ANY OF THE ABOVE DESCRIBED POLICIES BE CANCELLED BEFORE THE EXPIRATION DATE THEREOF, THE ISSUING INSURER WILL ENDEAVOR TO MAIL 10 DAYS WRITTEN NOTICE TO THE CERTIFICATE HOLDER NAMED TO THE LEFT, BUT FAILURE TO DO SO SHALL IMPOSE NO OBLIGATION OR LIABILITY OF ANY KIND UPON THE INSURER, ITS AGENTS OR REPRESENTATIVES. AUTHORIZED REPRESENTATIVE 
--	---

IMPORTANT

If the certificate holder is an ADDITIONAL INSURED, the policy(ies) must be endorsed. A statement on this certificate does not confer rights to the certificate holder in lieu of such endorsement(s).

If SUBROGATION IS WAIVED, subject to the terms and conditions of the policy, certain policies may require an endorsement. A statement on this certificate does not confer rights to the certificate holder in lieu of such endorsement(s).

DISCLAIMER

The Certificate of Insurance on the reverse side of this form does not constitute a contract between the issuing insurer(s), authorized representative or producer, and the certificate holder, nor does it affirmatively or negatively amend, extend or alter the coverage afforded by the policies listed thereon.

HUTTONSVILLE CORRECTIONAL CENTER

HUTTONSVILLE, WV

KITCHEN EQUIPMENT CONTRACTOR:

DOUGLAS EQUIPMENT
301 NORTH STREET
BLUEFIELD, WV 24701

(304) 327-0149 PHONE
(304) 325-3848 FAX

3/6/2007

Quotation

To: Huttonsville Correctional Center
 RFQ # COR61335
 State of West Virginia
 Dept. of Administration--Purchasing Division
 2019 Washington Street East PO Box 50130
 Charleston, WV 25305

From: Douglas Equipment
 Roy Ellison
 301 North St.
 Bluefield, WV 24701-4048
 Phone: (304) 327-0149

Item	Qty	Description	Sell Each	Sell Total
1	2	ea HEATED CABINET, MOBILE Carter-Hoffmann Model No. PH1215 Class: 100 Heated Cabinet, mobile, 2 doors, insulated, bottom mounted forced-air heating system, removable slides for 21- 12"x 20" pans, slides on 2-3/4" centers, s/s construction, 5" casters (2 swivel, 2 rigid), 120v, 1650w, 13.7amps, 60hz, 1ph, Energy Star		
	2	ea Tamper-resistant fasteners		
	2	ea Thermometer protector cover Weight: 570 lbs. total		
2	1	ea VEGETABLE PEELER, ELECTRIC Hobart Model No. 6460C+BUILDUP Vegetable Peeler, Correctional, 50-60 lb. potatoes in 1-3 minute cap., V-belt drive, removable abrasive silicon carbide disc & lexan liner, welded s/s construction, lockable controls, tamper resistant fasteners, 1 hp		
	1	ea 1-Yr. parts, labor & travel time during normal working hrs w/in the USA		
	1	ea 6460C-ELE00E 200-230/60/1		
	1	ea 6460C-SWIT04 4 minute timer switch 1ph only		
	1	ea 6460C-SWP0RH Switch on RH side		
	1	ea 6460C-LOCYES W/lockable controls		
	1	ea 6460C-CBTSSST Cabinet, base & trap- S/S strainer Weight: 213 lbs. total		
3	1	ea GRIDDLE, COUNTER UNIT, ELECTRIC Star Mfg. Model No 772T Class: 85 Ultra-Max® Griddle, electric, 72"L, 33-11/16"D, 18"H, 1" steel griddle plate, throttling therm. controls every 12", aluminum steel const., s/s front w/black trim, wrap-around s/s splash guard, grease trough & s/s drawer, 4" legs, 26,100 watts		
	1	ea 1 Yr, parts & labor warranty, std.		
	1	ea 208v/60/1-ph, std.		
	1	ea ES-UM72S Ultra-Max® Equipment Stand, 72"L, 30"D, 24"H, open base w/bottom shelf, stainless steel construction Weight: 902 lbs. total		
4	2	ea CONVECTION OVEN, ELECTRIC Blodgett Oven Model No. ZEPHAIRE E DBL Class: 85 Convection Oven, elec., double-deck, extra depth, solid state manual controls, single speed fan, (5) racks & (11) positions, dependent s/s solid doors, s/s front, sides & top, 6" s/s legs, 11kw each		

3/6/2007

Huttonsville Correctional Center

Item	Qty	Description	Sell Each	Sell Total
	2	ea (1) One year parts and labor and (2) two year door warranty, std.		
	2	ea To be Specified		
	2	ea Plus package (dependent glass doors, int'r light, 2-speed fan), per deck		
	4	ea PRISON PACKAGE Prison package (per section) - includes security control panel & s/s back Weight: 2220 lbs. total		
5	1	ea STEAMER, PRESSURE, DIRECT STEAM Southbend Model No. DC-3S Steamer, Pressure-Type, Direct, 3 compartments, 36" cabinet base, manual timer controls, s/s interior and exterior		
	1	ea Standard one year limited warranty		
	1	ea 115/60/1-ph, std.		
	1	ea 35 PSI std,		
	1	ea Cabinet base doors w/locking provisions		
	1	ea Correctional screws & tack welds Weight: 815 lbs. total		
6	1	ea TILTING KETTLE, DIRECT STEAM Blodgett Steam Model No KLT-100DS Class: 85 Tilting Kettle, Direct Steam, 100-gallon cap, two-thirds jacket, 304 s/s kettle, manual crank & steam control mounted in s/s console, tubular s/s tri legs w/flanged feet		
	1	ea 1 Year parts & labor warranties, standard		
	1	ea 3" Tangent draw-off valve w/strainer		
	1	ea Prison package: Tamper proof screws, tack welds and reinforced/solid bar rim Weight: 530 lbs. total		
7	1	ea FRYER, ELECTRIC Pitco Frialator Model No. SE18R-C-S Solstice Fryer, High Power, electric, heavy duty floor model, 70 - 90 lb fat capacity, computerized cooking control, melt cycle, boil out capacity, drain valve interlock switch, s/s tank, front, sides, 22 kw		
	1	ea 208v/60/3ph		
	1	ea Twin automatic basket lifts, add suffix "L"		
	1	ea CS Channel Strip Weight: 326 lbs. total		
8	1	ea FRYER FILTER, MOBILE Pitco Frialator Model No P18 Fryer Filter, mobile, low-profile design, with pump & hose assembly, 75 lb fat cap., s/s, for use with all 18 size fryers (except E18B)		
	1	pk P6071373 Filter Paper, flat, standard, 17-1/2" x 28" (BIF18/P18/P24/P34)		
	1	ea PP10733 Filter powder, 120-8 oz. pkts Weight: 156 lbs. total		

3/6/2007

Huttonsville Correctional Center

Item	Qty	Description	Sell Each	Sell Total
		PRICING INCLUDES DELIVER, UNCRATE, ASSEMBLE, SET IN PLACE AND ANCHOR ITEMS REQUIRED. PREVAILING WAGE RATES INCLUDED, AND BID BOND AS REQUIRED.		
			Total	70,520.00
			Grand Total	70,520.00



**PH1200, PH1215, PH1225 & PH1250
MOBILE HEATED SERVERS
FOR BULK FOODS**

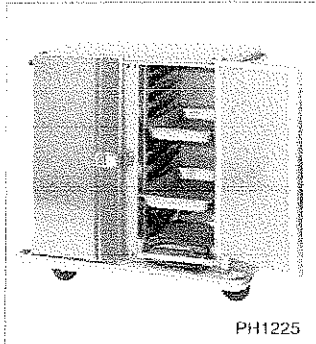

PH1225

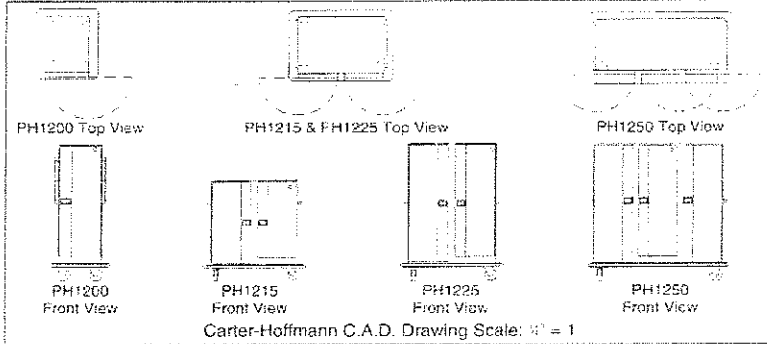

Carter-Hoffmann C.A.D. Drawing Scale: 1" = 1'

Model Number	Pan Capacity	Inside Working Height		Overall Dimensions						Caster Diameter		Shipping Weight	
	12 x 20 x 2 1/2"			Height	Depth	Width	Height	Depth	Width				
		in	mm	in	mm	in	mm	in	mm	in	mm	lbs	kgs
<input type="checkbox"/> PH1200	16	46	1168	58	1473	29 1/2	749	24	610	5	127	201	91
<input type="checkbox"/> PH1215	21	30	762	42	1067	29 1/2	749	41 1/2	1045	5	127	250	114
<input type="checkbox"/> PH1225	33	46	1168	58	1473	29 1/2	749	41 1/2	1045	5	127	300	136
<input type="checkbox"/> PH1250	50	46	1168	58	1473	29 1/2	749	56 1/2	1441	5	127	410	186

CONSTRUCTION... Completely welded cabinet construction and top corners, with outer cabinet formed to base and welded. All seams turned in to eliminate raw edges.

CABINET MATERIALS... Nickel-bearing type 300 series stainless steel, 20 gauge polished exterior wall, 24 gauge interior

BASE FRAME... 12 gauge stainless steel full depth bolsters with 1" x 1" stainless steel perimeter channel supports

CASTERS... 5" diameter, two rigid, two swivel polyurethane tread except for PH1200. All casters to be swivel type. Sealed delrin bearing and double ball bearing swivel Zerk grease fittings. Plate mounted and bolted to base in offset wheel-ahead pattern. Two casters fitted with brakes.

BUMPER... Non-marking gray vinyl bumper set in heavy-duty 3/8" extruded aluminum frame with reinforced corner "cut outs"

INSULATION... High density fiberglass insulation: 1" thick continuous wrap-around type

DOORS... Double panel stainless steel 20 gauge polished exterior and 24 gauge interior. Filled with 1" thick high density fiberglass insulation

GASKETS... High temperature gasket

LATCHES... Flush mounted, heavy duty sliding with exclusive grip handle.

HINGES... Concealed stainless steel hinge with 3/8" pin

HANDLES (TWO)... Horizontal full width heavy duty aluminum push handles with back-up plates. (Note: PH1200 unit to have two vertical push handles as shown)

PAN/TRAY SLIDES... Removable stainless steel assemblies. 20 gauge channel-type slides spaced on 2 1/2" centers.

THERMOMETER... Dial type with sensing bulb and bulb protector.

HEATING SYSTEM... Bottom mounted heater. Stainless steel construction. Removable without tools. 1600 watt inconel-sheathed heating element. High impedance protected, internally cooled fan motor Full range thermostat and power indicating light

ELECTRICAL CHARACTERISTICS... Operators on 120 volts, 60 cycle, single phase, 1650 watts, 13.7 amps. Ten foot rubber cord with 3 prong grounding plug, NEMA 5-15P.

PERFORMANCE... Capable of heating to 200 F (94 C). Preheat to 160 F (71 C). Approximately 25 minutes.

ACCESSORIES/OPTIONS

- Heater with on/off switch
- Heater with remote thermostat and probe, heater hold downs
- Heater with remote thermostat and probe, heater hold downs, on/off switch, removable power cord (locking)
- 220 volt, 1700 watts 50/60 hz
- 240 volt, 2023 watts 50/60 hz
- Menu card holder
- Top mount heavy duty transport latch
- Stainless steel push handles
- Removable canned heat
- Heater cover assembly (no heat)

CARTER-HOFFMANN
FOOD SERVICE EQUIPMENT
HEATED SERVERS

SPECIFICATIONS

Printed in U.S.A. P.S. 0599

Specifications subject to change through product improvement & innovation



CARTER-HOFFMANN CORP.
1551 McCormick Ave., Mundelein, IL 60060
Tel (847) 362-5500 • (800) 323-9793 • Fax (847) 367-8981
www.carter-hoffmann.com

Qty. _____ Item No. _____



701 S. Ridge Avenue, Troy, OH 45374
1-888-4HOBART • www.hobartcorp.com

**6430 • 6460
PEELER**

**6430 • 6460
PEELER**

SAVE TIME
SAVE WORK
SAVE FOOD

Two stainless steel vegetable peelers loaded with features that meet these important kitchen needs speed, no flats or bruising, reduced waste, gentle action. In three minutes or less the Models 6430 and 6460 will peel a full load of potatoes, carrots or other root vegetables.

These peelers have a large disc made of durable reinforced plastic—not cast iron—with the abrasive permanently bonded to its surface. Bigger but lighter—actually weighs 48% less than the ordinary cast iron type. No struggling to remove this disc for cleaning.

Convenience features such as built-in peel trap, lock-on hopper cover, adjustable legs and centralized controls make these Hobart Peelers a must for modern kitchens. Hopper with abrasives permanently bonded to its interior surface insures constant rotation of vegetables. All combine to let you tailor this peeler to your kitchen needs.

DISPOSER STAND with stainless steel legs and four bolt-down adjustable, leveling feet permit installation of food waste disposer for Hobart Models 6430 & 6460. Permits continuous drain disposal of all peelings (Peelers with stand with or without disposer not submitted for UL listing.) Stand is furnished with solenoid water control valve and air-gap type inlet.

Hobart Model FD2-50 with long upper housing Disposer, in single phase voltages below 250V. Specifically designed for use with the 6430 and 6460 peelers. (See illustration at right.)

Specifications, Details and Dimensions on Inside and Back.

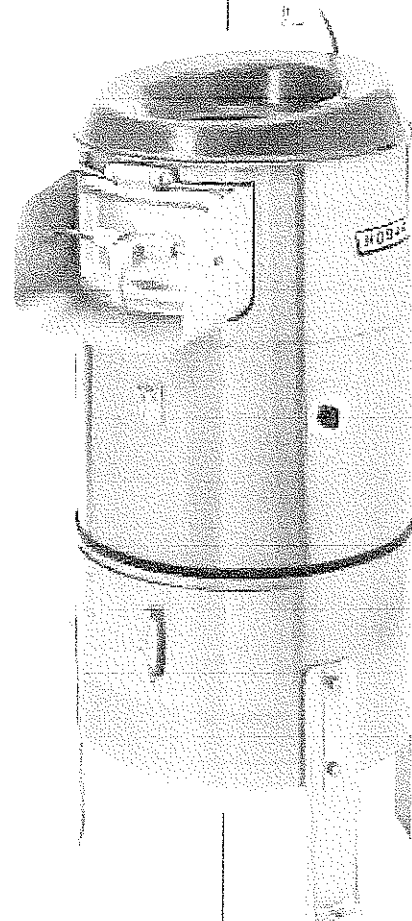
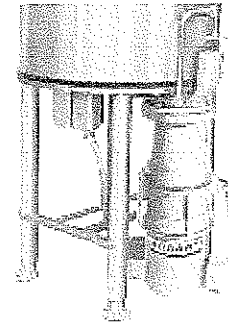

Shown with optional peel strainer and trap.

**6430 • 6460
PEELER**



**DETAILS, DIMENSIONS AND CONNECTIONS
PEELER WITH PEEL TRAP UNIT**

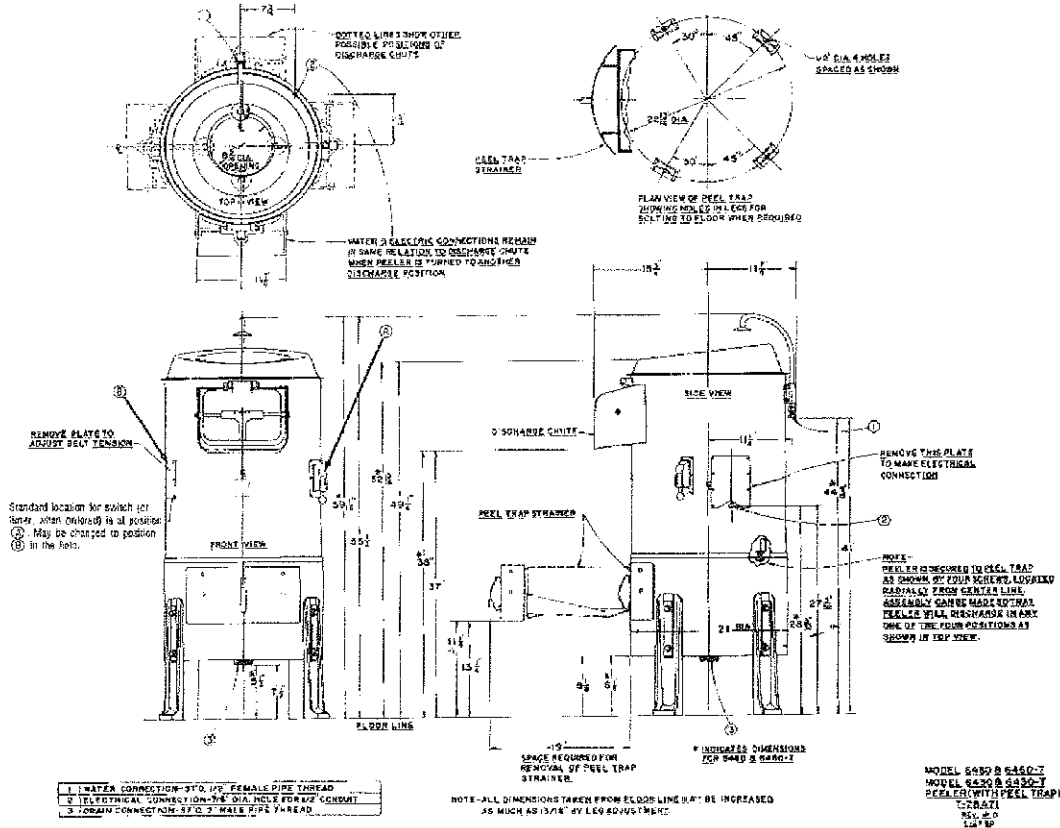

6430—Approx Shipping Weight Peeler and Peel Trap Unit —201 lbs
Approx Shipping Weight Peeler less Peel Trap Unit —147 lbs
Net Weight of Peeler and Peel Trap Unit —190 lbs

6460—Approx Shipping Weight Peeler and Peel Trap Unit —210 lbs
Approx Shipping Weight Peeler less Peel Trap Unit —156 lbs
Net Weight of Peeler and Peel Trap Unit —198 lbs



WARNING

ELECTRICAL AND GROUNDING CONNECTIONS MUST COMPLY WITH THE NATIONAL ELECTRICAL CODE AND/OR OTHER LOCAL ELECTRICAL CODES IN FORCE. PLUMBING CONNECTIONS MUST COMPLY WITH APPLICABLE SANITARY SAFETY AND PLUMBING CODES IN FORCE.



701 S Ridge Avenue, Troy, OH 45374
1-888-4HOBART • www.hobart.com

**6430 • 6460
PEELER**

**DETAILS, DIMENSIONS AND CONNECTIONS
OF PEELER WITH DISPOSER STAND**

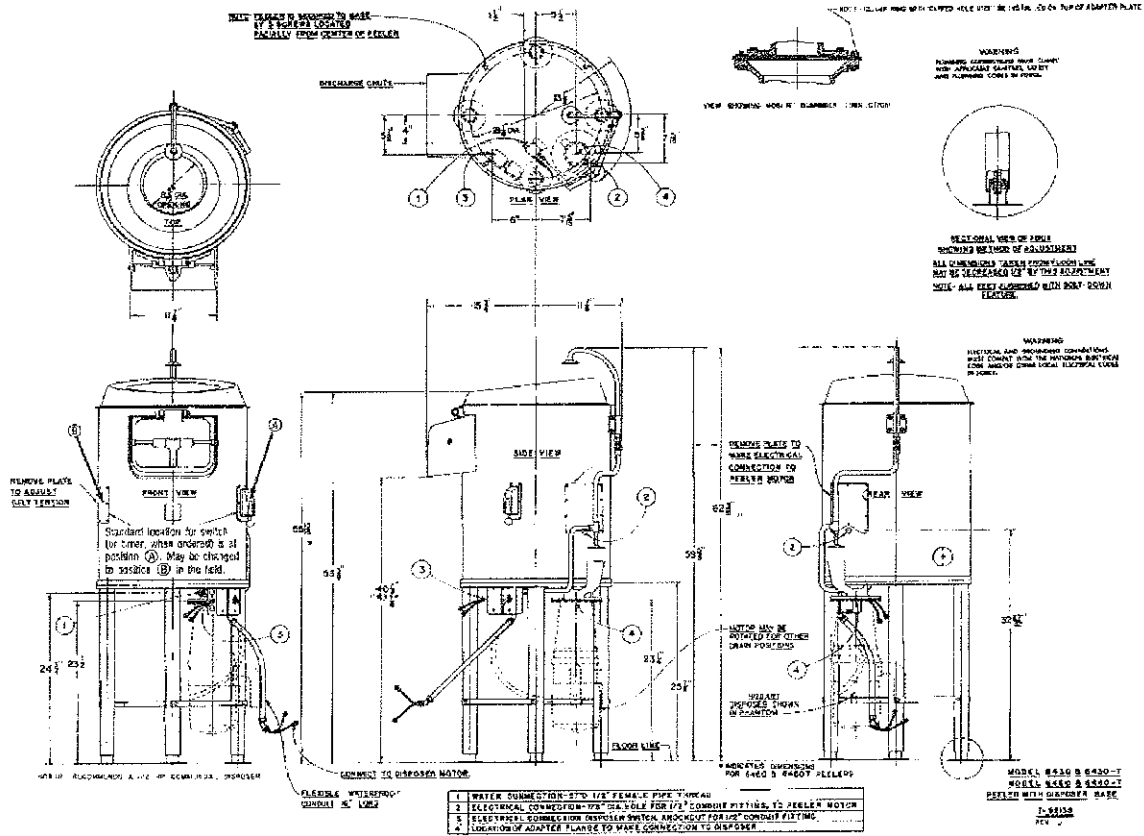

Single phase only
DO NOT use three phase disposers

- 6430—Net Weight of Peeler —142 lbs
- Domestic Shipping Weight of Peeler —147 lbs

- 6460—Net Weight of Peeler —150 lbs
- Domestic Shipping Weight of Peeler —156 lbs

- 6430—Net Weight of Disposer Stand —58 lbs
- Domestic Shipping Weight of Disposer Stand —85 lbs

- 6460—Net Weight of Disposer Stand —60 lbs
- Domestic Shipping Weight of Disposer Stand —70 lbs

NOTE—Disposer Stand shipped in carton separate from Peeler

**6430 • 6460
PEELER**



701 S. Ridge Avenue, Troy, OH 45374
1-888-4HOBART • www.hobartcorp.com

SPECIFICATIONS Listed by Underwriters Laboratories Inc and National Sanitation Foundation

MOTOR: ½ H.P. Model 6430; 1 H.P. Model 6460. The motor features manual reset overload protection, grease-packed ball bearings and ventilation within the peeler enclosure. Single phase is capacitor-start induction run, and three phase is polyphase squirrel-cage induction-run type.

ELECTRICAL SPECIFICATIONS: 115/60/1, 200-230/60/3, 460/60/3 UL Listed, 115/60/1, 220-240/50/1, 220-240/50/3, 380-415/50/3—Not submitted for UL Listing

SWITCH: Manual tumbler type, located on right side of discharge chute as standard. Switch can be relocated to other side of chute if desired.

TIMER—Models 6430T and 6460T: Synchronous 4-minute timer, adjustable for any increments from ½ minute up to 4 minutes, with 15-second markings etched on a large timer dial. This timer is furnished only in single phase specifications as standard.

DRIVE: Multigrip poly V-belt provides the direct speed reduction between motor and peeling disc. Belt adjustment may be accomplished from outside the machine. The stainless steel drive shaft is rigidly mounted on grease-packed ball bearings. Advanced designed triple protection sealing prevents entrance of water into shaft bearings.

PEELER UNIT: Cylindrical construction, heliarc-welded stainless steel with abrasive permanently bonded on interior surface of peeling hopper. A one piece, reinforced plastic molded, lightweight, easily removable, positive locking hopper cover is provided for easy cleaning. Quick-opening-removable aluminum hopper door and positive, cam-type pressure lock. Discharge chute is cast aluminum. To facilitate installation, the peeler unit can be positioned at 90° intervals in relation to the peel trap unit.

ABRASIVE DISC: An extremely lightweight fiberglass reinforced plastic disc is 20½ inches in diameter. The silicon-carbide abrasive is permanently bonded to the disc, assuring unequaled long service. Disc can be easily and quickly removed for cleaning by removing the lightweight hopper cover. Two angle mounted wipers provide positive movement of waste into the outlet.

OPTIONAL EQUIPMENT:

- PEEL TRAP UNIT:** This unit consists of a base, strainer and legs.

BASE—Constructed with a closed top which prevents moisture from entering motor and drive unit. The sloping bottom insures the diversion of water into a two inch male drain pipe connection.

STRAINER—The standard strainer has a stainless steel front and stainless steel rectangular drawer. The bottom of the drawer is removable for easy cleaning.

LEGS—There are four adjustable cast aluminum legs. The working height of the machine is 37" from the floor to the bottom of the discharge chute. The legs can be adjusted ¼" to compensate for floor variations.

- WATER INLET:** The inlet is the air-gap type, mounted at the rear of the peeler unit at sufficient height to meet plumbing codes. The water from the inlet impinges on the curved surface of the hopper cover to form a fan pattern of water into the unit. This design promotes interior self-cleaning and forms a water curtain which prevents undesirable splash.

WORKING CAPACITY: Model 6430 peels 30-33 pounds in one to three minutes. Model 6460 Peeler peels 50-60 pounds in similar time.

FINISH: Peeler and peel trap unit are #4 polished satin-finished stainless steel. Plastic molded hopper cover is gray. Door and handle, discharge chute and legs are cast aluminum and ball burnished for durability. Bottom of peeler unit is cushioned in resilient rubber trim molding.

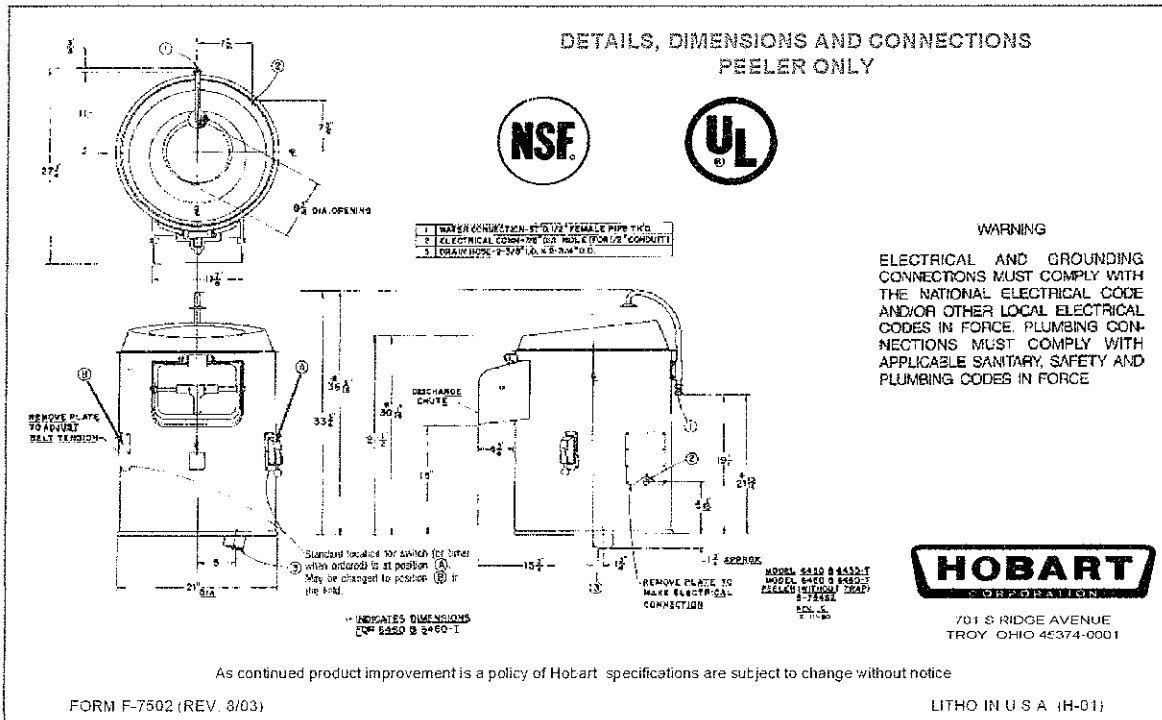



Star Manufacturing International, Inc.

ULTRA-MAX® ELECTRIC GRIDDLES

Models 724T, 736T, 748T, 760T & 772T

Features/Benefits:

- ★ Ultra-Max griddles are designed for the highest volume food service operations and provide maximum performance and reliability.
- ★ Snap Action Thermostatic control adjusts from 150° to 450°F and provides accurate temperature control. Internal plate sensor accurately measures the temperature of the griddle plate 3/16" from the cooking surface for instant response to surface temperature change and fast recovery.
- ★ Available in 24, 36, 48, 60 and 72 inch widths to meet your space and volume requirements.
- ★ Highly polished 1" thick steel plate for superior heat distribution fast recovery and energy efficient operation.
- ★ Custom designed 4350 watt element every 12" of cooking surface provides superior cooking performance.
- ★ Heavy-duty all-weld body construction with stainless steel front side panels, bull nose and splash guard.
- ★ "Euro-style" design with stylishly curved, ergonomically advanced front panel providing easy access and viewing of controls.
- ★ Spatula wide 3-1/2" front grease trough and grease chute for easier cleaning.
- ★ Large 6 quart stainless steel grease drawer.
- ★ Extra-heavy-duty 4" adjustable legs to fit your countertop needs.
- ★ Floor model stands available for free standing unit. Optional casters available.

Applications:

For breakfast, lunch or dinner, the Ultra-Max electric snap action griddles provide flexibility for a variety of menu items. Perfect for high volume operations.

Construction:

Ultra-Max griddles feature 1" thick highly polished steel griddle plate, 5" tapered stainless steel splash guard, 3-1/2" wide front access stainless steel grease trough, stainless steel 6 quart capacity grease drawer, and stainless steel front panels, side panels, and bull nose. Models 760T and 772T house two 6 quart grease drawers. Includes a 4350 watt element every 12" of width controlled by snap action electric thermostat. Griddles are equipped with a junction box at the rear for making electrical connections. Models 760T and 772T are equipped with 2 junction boxes. Heavy-duty 4" legs are included.

Warranty:

Ultra-Max electric griddles are covered by Star's one year parts and labor warranty.

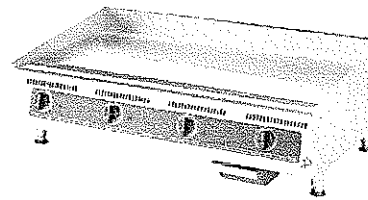

Model 748T

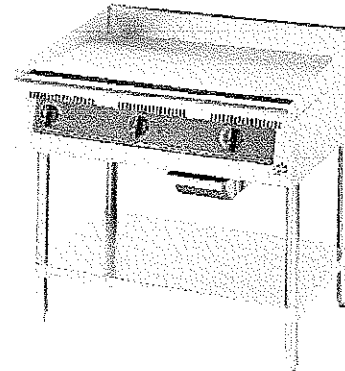

Model 736T
Shown with Optional Floor Stand



Star Manufacturing International Inc. - 10 Sunnen Drive - P.O. Box 430129 - St. Louis MO 63143-3800
Phone: (800) 264-7827 - FAX: (800) 264-8666 - www.star-mfg.com

S252/0056



Star Manufacturing International, Inc

Ultra-Max® Electric Griddles

ULTRA-MAX® ELECTRIC GRIDDLES

Models 724T, 736T, 748T, 760T & 772T

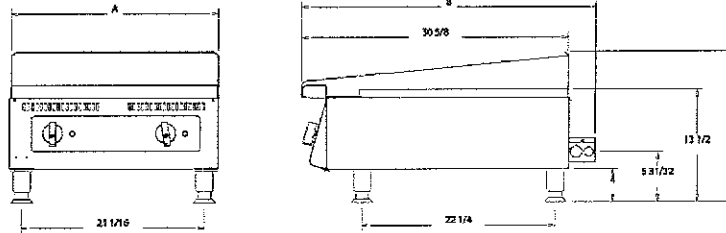

Specifications

Model No.	Dimensions			No. Controls	Watts	Grid Area	Plate Thickness	Approximate Weight	
	(A) Width Inches	(B) Depth Inches	(C) Height Inches					Installed	Shipping
724T	24" (61 cm)	33-11/16" (85.5 cm)	18" (45.7 cm)	2	8,700	573 sq. in. (3,697 sq cm)	1" (2.54 cm)	220 lbs. (99.7 kg)	290 lbs. (130.5 kg)
736T	36" (91.4 cm)	33-11/16" (85.5 cm)	18" (45.7 cm)	3	13,050	860 sq. in. (5,545 sq cm)	1" (2.54 cm)	330 lbs. (149.5 kg)	389 lbs. (175.1 kg)
748T	48" (121.9 cm)	33-11/16" (85.5 cm)	18" (45.7 cm)	4	17,400	1146 sq. in. (7,394 sq cm)	1" (2.54 cm)	440 lbs. (199.4 kg)	520 lbs. (234 kg)
760T	60" (152.4 cm)	33-11/16" (85.5 cm)	18" (45.7 cm)	5	21,750	1433 sq. in. (9,242 sq cm)	1" (2.54 cm)	550 lbs. (249.2 kg)	656 lbs. (295.2 kg)
772T	72" (182.9 cm)	33-11/16" (85.5 cm)	18" (45.7 cm)	6	26,100	1719 sq. in. (11,091 sq cm)	1" (2.54 cm)	660 lbs. (299.0 kg)	780 lbs. (351 kg)

Electrical Data

Model	Total KW.	Voltage	AMPS-1 Phase	KW-Load Phase			AMPS Per Phase		
				X-Y	X-Z	Y-Z	X	Y	Z
724T	8.7	208	41.8	4.35	-	4.35	20.9	36.2	20.9
	8.7	240	36.3	4.35	-	4.35	18.1	31.3	18.1
736T	13.05	208	62.7	4.35	4.35	4.35	36.2	36.2	36.2
	13.05	240	54.4	4.35	4.35	4.35	31.4	31.4	31.4
748T	17.4	208	83.6	8.7	4.35	4.35	55.3	55.3	36.2
	17.4	240	72.5	8.7	4.35	4.35	48	48	31.4
760T**	21.8	208	Dual Supply: 62.7 A. One Circuit & 41.8 A. Other Circuit	4.35	4.35	4.35	36.2	36.2	36.2
				4.35	-	4.35	20.9	36.2	20.9
			Dual Supply: 54.4 A. One Circuit & 36.3 A. Other Circuit	4.35	4.35	4.35	31.4	31.4	31.4
772T**	26.1	208	Dual Supply 62.7 EA. Circuit	4.35 ea	4.35 ea	4.35 ea	36.2 ea	36.2 ea	36.2 ea
				4.35 ea	4.35 ea	4.35 ea	31.4 ea	31.4 ea	31.4 ea
			Dual Supply 54.4 EA. Circuit	4.35 ea	4.35 ea	4.35 ea	31.4 ea	31.4 ea	31.4 ea

**INDICATES DUAL SUPPLY CIRCUITS

Typical Specifications

Gas griddles are constructed of stainless steel. Control knobs are protected by a stainless steel built nose front. Griddle plate is a 1" (2.54 cm) thick highly polished steel plate with 5" (12.7 cm) high tapered wrap-around stainless steel splash guard. Unit has 3-1/2" (8.3 cm) wide front grease trough with grease chute and a 6 qt. (5.68 L) capacity stainless steel grease drawer. Models 760T and 772T house two each 6 quart (5.68 L) grease drawers. Units are equipped with a 4350 watt incoloy sheath element every 12" (330.48 cm) of griddle width and are controlled by a snap action thermostat. A terminal block is provided for making electrical connections. Models 760T and 772T are equipped with two electric connection boxes. Griddles are supplied with 4" (10.2 cm) high stainless steel legs that have a 1-5/8" (1.5 cm) adjustment. Units are approved for installation within 1" (2.54 cm) of side and rear wall combustible surfaces and are cULus Classified and UL classified to NSF Standard 4 Sanitation. Printed in the U.S.A.

Due to periodic changes in designs, methods, procedures, policies and regulations, the specifications contained in this sheet are subject to change without notice. While Star Manufacturing exercises good faith efforts to provide information that is accurate, we are not responsible for errors or omissions in information provided or conclusions reached as a result of using the specifications. By using the information provided, the user assumes all risks in connection with such use.

Star Manufacturing International Inc. - 10 Sunnen Drive - P.O. Box 430129 - St. Louis MO 63143-3800

Phone: (800) 264-7827 - FAX: (800) 264-6666 - www.star-mfg.com



Star Manufacturing International, Inc.

ULTRA-MAX® EQUIPMENT STANDS

**Models ES-UM24S, ES-UM24SF, ES-UM24SFC,
ES-UM36S, ES-UM36SF, ES-UM36SFC, ES-UM48S, ES-UM48SF,
ES-UM48SFC, ES-UM60S, ES-UM60SF, ES-UM60SFC,
ES-UM72S, ES-UM72SF & ES-UM72SFC**

Features/Benefits:

- ★ Use equipment stands for Ultra-Max char-broilers griddles and hot plates
- ★ Three different designs:
 - Pre-Cut Floor Models** - Pre-cut 19" Height for use with caster kit (model SMCASST) casters - stand connects to equipment
 - Floor Model Stands** - Stationary stand with bullet feet connects directly to equipment
 - Equipment Stands - (w/ Optional Casters)** - Stand alone, choose between stationary models or stands with optional casters
- ★ Stainless steel stands available in 24", 36", 48", 60" and 72" widths
- ★ Equipment stands have stainless steel top shelves and are equipped with a 1" lip to prevent equipment from sliding off sides and back
- ★ Floor models have bullet feet with one inch adjustment.
- ★ Optional four piece caster set (model SMCASST) available for all stands.

Applications:

Heavy-duty equipment stands provide years of trouble free service and accurate cooking height for all Ultra-Max equipment.

Quality Construction:

Stands are constructed of heavy gauge stainless steel. Legs are 1-5/8" (4.1cm) diameter stainless steel pipe that add strength and durability.

Warranty:

Equipment stands are covered by Star's one year parts and labor warranty.

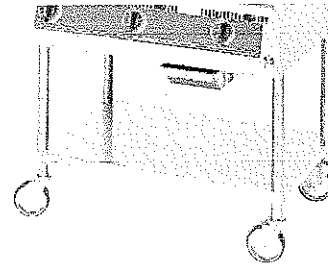

**Models ES-UM36SFC
Pre-Cut Floor Models with
optional casters**

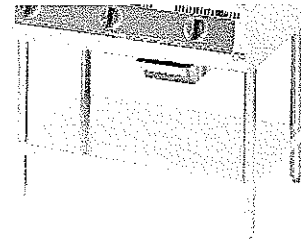

**Models ES-UM36SF
Floor Model**

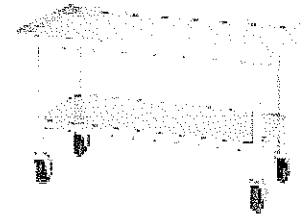

**Models ES-UM36S with
optional casters**



Star Manufacturing International Inc. - 10 Sunnen Drive - P.O. Box 430129 - St Louis MO 63143-3800
Phone: (800) 264-7827 - FAX: (800) 264-6666 - www.star-mfg.com

S214/0106

Ultra-Max® Equipment Stands



Star Manufacturing International, Inc.

ULTRA-MAX® EQUIPMENT STANDS

Models ES-UM24S, ES-UM24SF, ES-UM24SFC, ES-UM36S, ES-UM36SF, ES-UM36SFC, ES-UM48S, ES-UM48SF, ES-UM48SFC, ES-UM60S, ES-UM60SF, ES-UM60SFC, ES-UM72S, ES-UM72SF & ES-UM72SFC

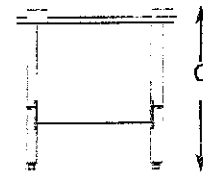
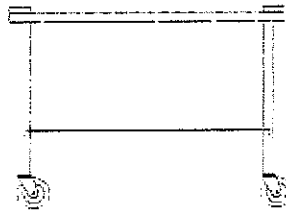
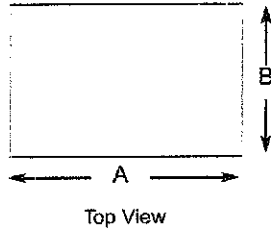

Specifications

Model No.	Description	(A) Width Inches (cm)	(B) Depth Inches (cm)	(C) Height Inches (cm)	Shipping Weight lbs. (kg)
Pre-Cut Floor Stands For Use With Casters					
ES-UM24SFC	24" Stainless Steel Floor Model	23 (58.4)	24-1/4 (61.6)	19 (48.26)	51 (23.2)
ES-UM36SFC	36" Stainless Steel Floor Model	35 (88.9)	24-1/4 (61.6)	19 (48.26)	68 (30.9)
ES-UM48SFC	48" Stainless Steel Floor Model	47 (119.3)	24-1/4 (61.6)	19 (48.26)	88 (39.9)
ES-UM60SFC	60" Stainless Steel Floor Model	59 (149.9)	24-1/4 (61.6)	19 (48.26)	105 (47.7)
ES-UM72SFC	72" Stainless Steel Floor Model	71 (180.3)	24-1/4 (61.6)	19 (48.26)	122 (55.4)
Floor Model Stands with Bullet Style Feet					
ES-UM24SF	24" Stainless Steel Floor Model	23 (58.4)	24-1/4 (61.6)	24 (61)	25 (11.3)
ES-UM36SF	36" Stainless Steel Floor Model	35 (88.9)	24-1/4 (61.6)	24 (61)	36 (16.3)
ES-UM48SF	48" Stainless Steel Floor Model	47 (119.4)	24-1/4 (61.6)	24 (61)	42 (19.1)
ES-UM60SF	60" Stainless Steel Floor Model	59 (149.9)	24-1/4 (61.6)	24 (61)	49 (22.2)
ES-UM72SF	72" Stainless Steel Floor Model	71 (180.3)	24-1/4 (61.6)	24 (61)	56 (25.4)
Equipment Stands (Casters Optional)					
ES-UM24S	24" All Stainless Steel	24 (61.0)	30 (76.2)	24 (61.0)	51 (23.2)
ES-UM36S	36" All Stainless Steel	36 (91.4)	30 (76.2)	24 (61.0)	68 (31.0)
ES-UM48S	48" All Stainless Steel	48 (121.9)	30 (76.2)	24 (61.0)	88 (40.0)
ES-UM60S	60" All Stainless Steel	60 (152.4)	30 (76.2)	24 (61.0)	105 (47.7)
ES-UM72S	72" All Stainless Steel	72 (182.8)	30 (76.2)	24 (61.0)	122 (55.4)
SM-CAST	Caster Kit (4 in a set) (Casters will add 6" to height of stand).				

Typical Specifications

Equipment stands are constructed of heavy duty stainless steel with 1-5/8" (4.1 cm) diameter stainless steel pipe legs for added strength and durability. Plastic feet with an adjustment of 1" (2.5 cm) are standard on stationary stands. The lower shelf on the stand is stainless steel, the top shelf has tabs to prevent units from sliding off rear or side of stand. Equipment stands are listed by National Sanitation Foundation. Printed in the U.S.A.

Due to periodic changes in designs, methods, procedures, policies and regulations, the specifications contained in this sheet are subject to change without notice. While Star Manufacturing exercises good faith efforts to provide information that is accurate, we are not responsible for errors or omissions in information provided or conclusions reached as a result of using the specifications. By using the information provided, the user assumes all risks in connection with such use.

Star Manufacturing International Inc. - 10 Sunnen Drive - P.O. Box 430129 - St Louis MO 63143-3800
 Phone: (800) 264-7827 - FAX: (800) 264-6666 - www.star-mfg.com



MODEL ZEPHAIRE-E

Full-size Electric Convection Oven

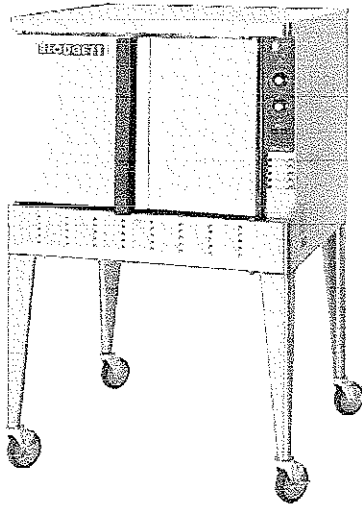

OPTIONS AND ACCESSORIES

(AT ADDITIONAL CHARGE)

- **Legs/casters/stand:**
 - 6" (152mm) seismic legs
 - 6" (152mm) casters
 - 4" (102mm) low profile casters (double only)
 - 25" (635mm) stainless steel open stand with rack guides
- Solid stainless back panel
- Extra oven racks
- Plus package (glass doors, interior lights, and a two speed motor)
- Vent connector
- 480 VAC, 3 phase
- Extended warranty

Project _____

Item No. _____

Quantity _____

Refer to operator manual specification chart for listed model name.

Extra depth baking compartment- accepts five 18" x 26" standard full-size baking pans in left-to-right or front-to-back positions.

All data is shown per oven section, unless otherwise indicated.

Refer to operator manual specification chart for listed model name

EXTERIOR CONSTRUCTION

- Full angle-iron frame
- Stainless steel front, top, and sides
- Solid dependent stainless steel doors
- Porcelain door handle with simultaneous door operation
- Triple-mounted pressure lock door design with tumbuckle assembly
- Removable front control panel
- Solid mineral fiber insulation at top, back, sides and bottom

INTERIOR CONSTRUCTION

- Double-sided porcelainized baking compartment liner (14 gauge)
- Aluminized blower wheel
- Five chrome-plated racks, eleven rack positions with a minimum of 1-5/8" (41mm) spacing

OPERATION

- Three tubular heaters
- Solid state thermostat with temperature control range of 200°F (93°C) to 500°F (260°C)
- Single speed fan motor
- 1/3 horsepower blower motor with automatic thermal overload protection
- Control area cooling fan

STANDARD FEATURES

- Solid state manual controls with separate dials for thermostat and timer
- 25" (635mm) adjustable stainless steel legs (for single units)
- 6" (152mm) adjustable stainless steel legs (for double sections)
- 60 minute electric timer with buzzer
- One year parts and labor warranty*
- Three year limited oven door warranty*

* For all international markets, contact your local distributor.



BLODGETT OVEN COMPANY

www.blodgett.com

44 Lakeside Avenue, Burlington, VT 05401

Toll Free: (800) 331-5842 • Phone: (802) 860-3700 • Fax: (802) 864-0183

ZEPHAIRE-E



MODEL ZEPHAIRE-E

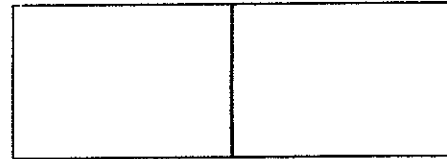

APPROVAL/STAMP

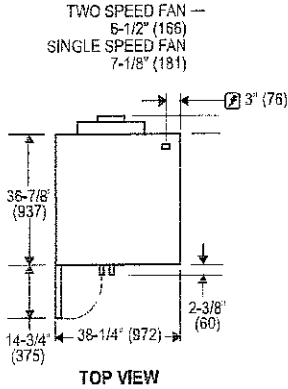

TOP VIEW

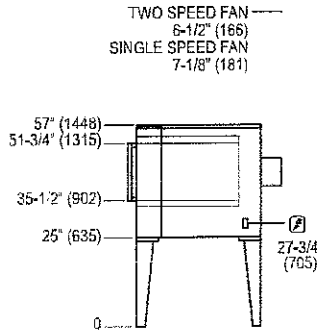

SINGLE

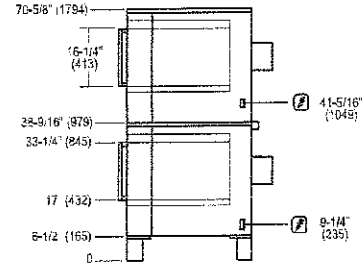

DOUBLE

Dimensions are in inches (mm)

SHORT FORM SPECIFICATIONS

Provide Blodgett full-size convection oven model ZEPHAIRE-E, (single/double) compartment. Each compartment shall have porcelainized steel liner and shall accept five 18" x 26" standard full-size bake pans in left-to-right or front-to-back positions. Doors shall be solid stainless steel with porcelain door handle and simultaneous door operation. Unit shall be electrically heated with three tubular heaters. Air in baking chamber distributed by single inlet blower wheel powered by a single-speed, 1/3 HP motor with thermal overload protection. Each chamber shall be fitted with five chrome-plated removable racks. Control panel shall be recessed with Cook/Cool Down mode selector solid state manual infinite thermostat (200 - 500°F), and 60-minute timer. Provide options and accessories as indicated.

DIMENSIONS:

- Floor space: 38-1/4" (972mm) W x 36-7/8" (936mm) L
- Product clearance: 1/2" from combustible and non-combustible construction.
- Interior: 29" (737mm) W x 20" (508mm) H x 28-1/4" (718mm) D
- If oven is on casters add to all height dimensions:
- Single 4-1/2" (114mm)
- Double 2-1/4" (57mm)

MAXIMUM INPUT:

- Single 11KW
- Double 22Kw (11KW each section)

POWER SUPPLY:

- 208 VAC 60 Hz 1 phase 11KW 51/0/51 Amperes,
- 208 VAC 60 Hz 3 phase 11KW 31/29/29 Amperes,
- 220/240 VAC 60 Hz 1 phase 11KW 44/0/44 Amperes,
- 220/240 VAC 60 Hz 3 phase 11KW 26/24/24 Amperes,
- 440 VAC 60 Hz 3 phase 11KW 15/14/14 Amperes,
- 480 VAC 60 Hz 3 phase 11KW 14/13/13 Amperes,

1/3 HP, 1 speed motor, 1725 rpm (60 Hz)

(50 Hz. ovens for 400/230, 380Y/220 VAC or 415Y/240 VAC (4 wire) 3 phase are available)

This oven contains a mercury relay. DO NOT put mercury relay in trash. Relay must be recycled or disposed of as hazardous waste.

NOTE: The company reserves the right to make substitutions of components without prior notice

MINIMUM ENTRY CLEARANCE:

- Uncrated 32-1/16" (814mm)
- Crated 37-1/2" (953mm)

SHIPPING INFORMATION:

- Approx. Weight:
- Single: 545 lbs (247 kg)
- Double: 1060 lbs (481 kg)
- Crate sizes:
- 37-1/2" (952mm) x 43-1/2" (1105mm) x 51-3/4" (1315mm)

BLODGETT OVEN COMPANY

www.blodgett.com

44 Lakeside Avenue, Burlington, VT 05401 Toll Free: (800) 331-5842 • Phone: (802) 860-3700 • Fax: (802) 864-0183

Printed in U.S.A.

NOTE: FOR COMMERCIAL USE ONLY

P/N 35025 Rev L (5/06)



A Middleby Company

**DIRECT STEAM
COMPARTMENT COOKER
WITH CABINET BASE**

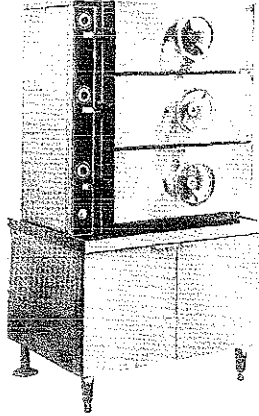

SPECIFICATIONS:

Shall be a Model _____, pressure compartment cooker operating on direct steam. The cooker shall be constructed of all-welded satin finish stainless steel, type 304. The doors shall have a removable inner liner of aluminum plate with full perimeter gasket seal, and a wheel-and-screw closing mechanism. The doors, with a clear opening of 10-1/4" x 26-3/8" (260 x 670mm), shall latch upon closing, and shall open 15° upon latch release. Compartment operation shall be at a maximum pressure of 6 psi (41kPa).

The control housing shall be constructed of stainless steel with a full-access removable panel. The timing of each compartment shall be independently controlled by:

- Automatic timer controls with visible and audible signals. At the end of the cooking cycle, the controls automatically shut off and exhaust the incoming steam, drain the condensate from the compartment, and sound a continuous signal until turned off manually.

Each cooking compartment shall have either removable shelf supports with one slide-out shelf (second shelf optional) or removable universal pan supports. The capacities shall range as follows:

- Shelf supports: Four full size (1/1 gastronorm) pans, 2-1/2' or 4" (64mm or 100mm) deep

The compartment cooker shall be mounted on a cabinet base with full perimeter angle frame, reinforced counter, all stainless steel #4 finish type 304 exterior, hinged doors and 6" (152mm) stainless steel legs with adjustable bullet feet on the front and flanged on the rear.

Model	Compartments	Capacity
DC-2	2	8-16 Pans
DC-3	3	12-24 Pans

OPERATION SHALL BE BY:

Direct non-toxic steam incoming at a minimum of 15 psi (103 kPa) with a flow of 150 psi (68kg) per hour. A pressure reducing valve shall provide compartment pressure of 6 psi (41 kPa) and a control system is provided to cool the condensate drain.

The control shall be equipped for operate on 115 VAC 1 Phase 60 Hz.

OPTIONAL ITEMS AT EXTRA COST:

- Stainless steel rear panel
- Front flange feet
- 220 VAC, 1 Phase 60 Hz
- 240 VAC, 1 Phase, 60 Hz

ACCESSORIES:



- Extra shelf
- 12" x 20" x 2-1/2" perforated stainless steel pan
- 12" x 20" x 2-1/2" solid stainless steel pan
- 12" x 20" x 4" perforated stainless steel pan
- 12" x 20" x 4" solid stainless steel pan
- Ball float trap
- Spray and rinse assembly

Job _____
Item# _____



Models: DC-2S DC-3S

SERVICE CONNECTIONS

-  - ELECTRICAL CONNECTION: 1/2" conduit connection to controls. 2 AMPS per compartment. 120-60-1 or 220-50-1
-  - DRAIN: 2" IPS piped to open floor drain. No solid connection
-  - STEAM SUPPLY: 3/4" IPS for incoming steam at 40-50 PSI (276-345 kPa)¹

¹Pressure reducing valve is required if incoming pressure exceeds 50 PSI (345 kPa)

DC-2, DC-3

REAR FLANGED FOOT DETAIL:
2 EQUALLY SPACED
Ø 7/16" (11mm) HOLES
ON 2.5" (63mm) B.C.

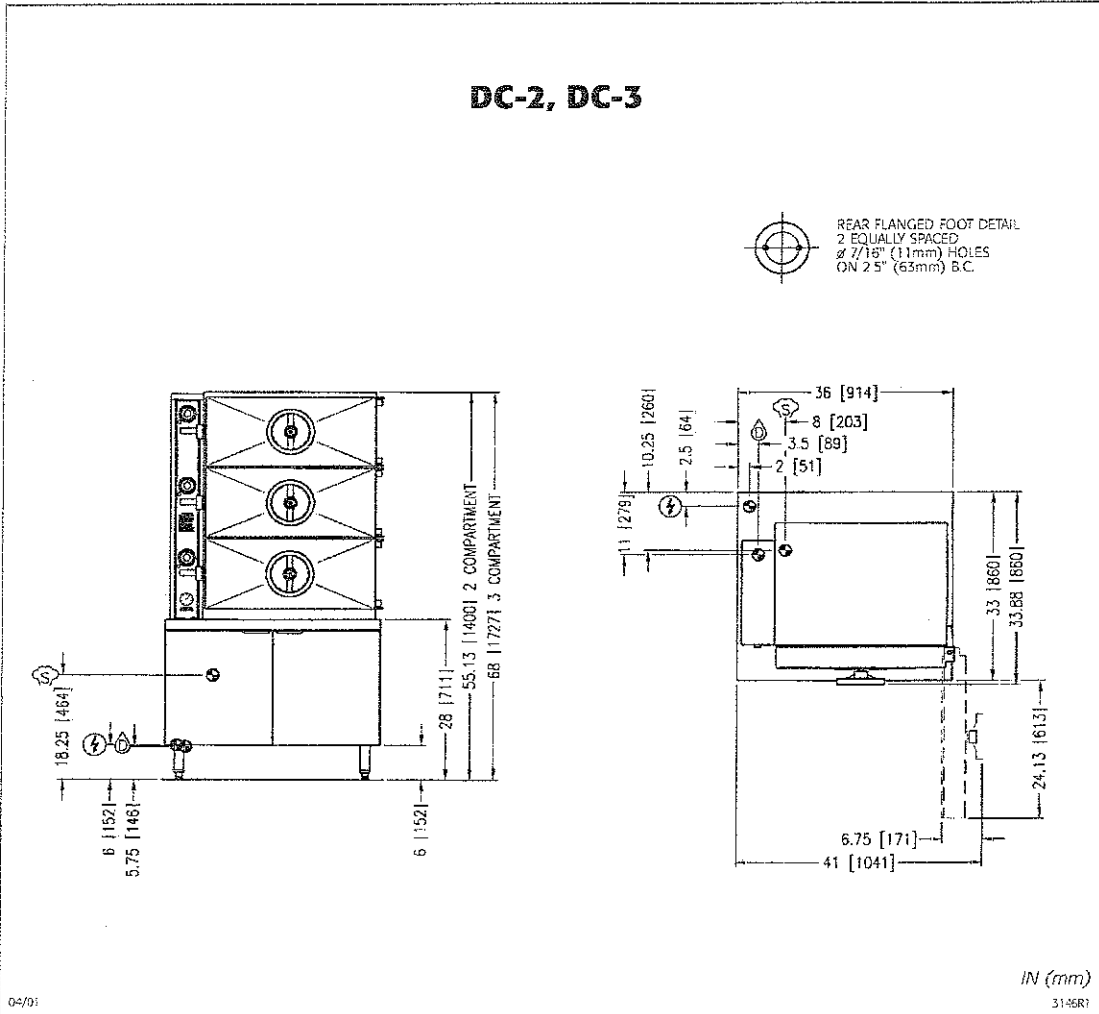

**INTENDED FOR COMMERCIAL USE ONLY.
NOT FOR HOUSEHOLD USE**



1100 Old Honeycutt Rd. Fuquay-Varina, NC 27526
www.southbendnc.com

Form DC



KLT-DS
Direct Steam Tilting Kettle on Legs

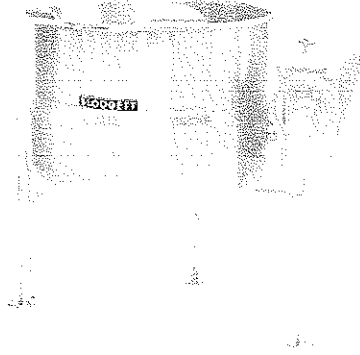

Project _____
Item No _____
Quantity _____

- Model KLT-20DS - 20 gallon (76 litres) direct steam tri-leg tilting kettle
- Model KLT-30DS - 30 gallon (114 litres) direct steam tri-leg tilting kettle
- Model KLT-40DS - 40 gallon (151 litres) direct steam tri-leg tilting kettle
- Model KLT-60DS - 60 gallon (227 litres) direct steam tri-leg tilting kettle
- Model KLT-80DS - 80 gallon (303 litres) direct steam quad-leg tilting kettle
- Model KLT-100DS - 100 gallon (379 litres) direct steam quad-leg tilting kettle

CONSTRUCTION

- Water resistant construction
- 304 stainless steel construction
- 2/3 jacketed
- 316 stainless steel interior cooking surface for added corrosion resistance for 20, 30 and 40 gallon
- Hemispherical design on bottom of kettle for superior heat circulation
- Tilt mechanism permits kettle to tilt forward 90° to empty

STANDARD FEATURES

- Steam control valve mounted in console
- Stainless steel faucet bracket
- One year parts and labor warranty*

* For all international markets, contact your local distributor.



OPTIONS AND ACCESSORIES
(AT ADDITIONAL CHARGE)

- Etched markings
 - Gallons
 - Litres
- Draw Off valves and accessories
 - 2" (50mm) draw off valve
 - 3" (76mm) draw off valve
 - 2" (50mm) dairy valve
 - 3" (76mm) dairy valve
 - Perforated strainer for draw off
 - Solid stainless steel disc for draw off valve
- Faucets
 - Single pantry faucet with swing spout
 - Double pantry faucet with swing spout
- Covers
 - One piece lift off stainless steel cover
 - Spring assist hinged stainless steel cover
- 316 stainless steel liner for 60, 80 and 100 gallon
- 50 PSI (345 kPa) high pressure operation for higher cooking temperature
- Tri-basket assembly
- Pan carrier for 40 and 100 gallon
- Strainer hook
- Graduated measuring strip
- Steam trap assembly consisting of steam trap check valve, and Y strainer
- Pour strainer
- Correctional package

KLT-DS TILTING KETTLE ON LEGS

BLODGETT

44 Lakeside Avenue, Burlington, VT 05401
Toll Free: (800) 331-5842 • Phone: (802) 860-3700 • Fax: (802) 864-0183



KLT-DS TILTING KETTLE ON LEGS



APPROVAL/STAMP

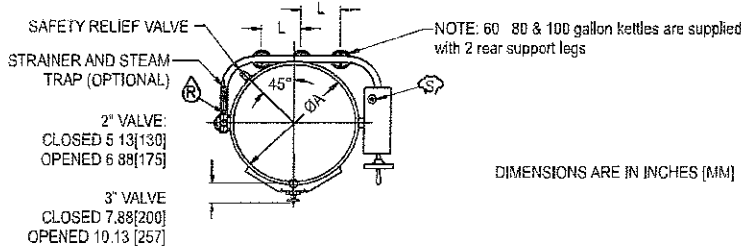

DIMENSIONS ARE IN INCHES [MM]



FLANGED FOOT DETAIL
4 EQUALLY SPACED
Ø7/16" [11mm] HOLES
ON 3 [76] B.C.

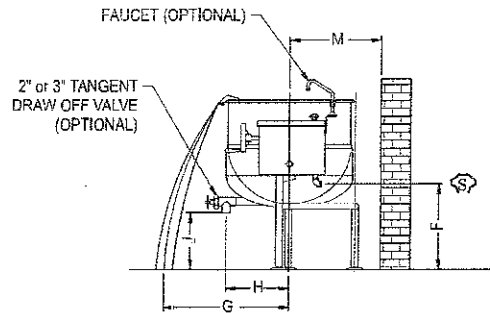
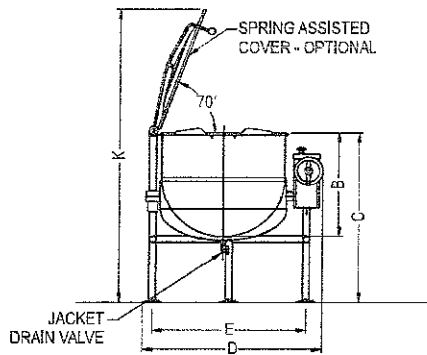

MODEL	A	B	C	D	E	F	G	H (2")	H (3")	J (2")	J (3")	K	L	M
KLT-20DS	21[535]	18[460]	37[940]	34.75[885]	28.5[724]	22[559]	25.63[651]	12[305]	13.25[337]	17[432]	16.5[419]	59.5[1512]	-	15.38[391]
KLT-30DS	24[610]	20[510]	37[940]	37.75[960]	31.5[800]	20.75[527]	27.13[689]	12.5[317]	14.25[362]	15[381]	14.5[368]	62.5[1588]	-	15.38[391]
KLT-40DS	26[660]	22.5[570]	37[940]	39.75[1010]	33.5[850]	20.25[514]	28.63[727]	13[330]	15.25[387]	12.5[318]	12[305]	64[1626]	-	16.38[416]
KLT-60DS	29.5[750]	26[660]	40.5[1029]	43.25[1100]	37[940]	21.5[546]	30.13[765]	15.5[394]	15.5[394]	14.5[368]	14[356]	74[1879]	9.5[241]	18.38[467]
KLT-80DS	33[840]	28[710]	42.5[1080]	46.75[1185]	40.5[1030]	20[508]	32.63[828]	14.5[368]	16.25[413]	12.5[318]	12[305]	76[1930]	11[279]	19.88[505]
KLT-100DS	35.5[902]	30[762]	42.5[1080]	49.25[1251]	43[1092]	27[686]	39.25[997]	18[457]	20.25[514]	10.5[267]	10[254]	79[2007]	12.5[318]	21.5[546]

SHORT FORM SPECIFICATIONS

Provide Blodgett model KLT-20DS (20 gallon), KLT-30DS (30 gallon), KLT-40DS (40 gallon), KLT-60DS (60 gallon), KLT-80DS (80 gallon) or KLT-100DS (100 gallon) direct steam tilting kettle on legs. The unit shall have a double wall interior to form a steam jacket around the lower 2/3 of the kettle. The bottom of the kettle shall be of hemispherical design for superior heat circulation. Unit shall have stainless steel mounting frame to support the kettle and tilt console shall conceal the steam piping, house the steam control valve and tilt mechanism. Each leg shall be fitted with a four hole adjustable flanged foot for securing to the floor. The tilt mechanism shall permit the kettle to tilt forward a full 90° for complete emptying. The tilting mechanism shall be self locking for positive stop action. Construction shall be all welded satin finish 304 stainless steel. 20, 30 and 40 gallon models shall have a 316 stainless steel liner. Unit shall be ASME code stamped and National Board registered. Provide options and accessories as indicated.

PIPING REQUIREMENTS:

Steam Supply 3/4" IPS (19 mm)
Condensate Return 1/2" IPS (13 mm)

STEAM PRESSURE:

Minimum 5 PSI (34 kPa)
Maximum 30 PSI (207 kPa)

Pressure reducing valve required if incoming steam pressure exceeds the kettle rating.

SHIPPING INFORMATION:

Approx. Weight:

KLT-20DS 145 lbs (66 kg)
KLT-30DS 160 lbs (72 kg)
KLT-40DS 225 lbs (102 kg)
KLT-60DS 315 lbs (143 kg)
KLT-80DS 325 lbs (147 kg)
KLT-100DS 350 lbs (159 kg)

NOTE: The company reserves the right to make substitutions of components without prior notice.

BLODGETT

44 Lakeside Avenue, Burlington, VT 05401
Toll Free: (800) 331-5842 • Phone: (802) 860-3700 • Fax: (802) 864-0183



**Solstice Electric Series Fryers
Model SE14, SE14T & SE18**

All Models Available in 17kW or 22kW

Project _____
Item No _____
Quantity _____

Model SE14, SE14T & SE18 Solstice Electric Series Fryers

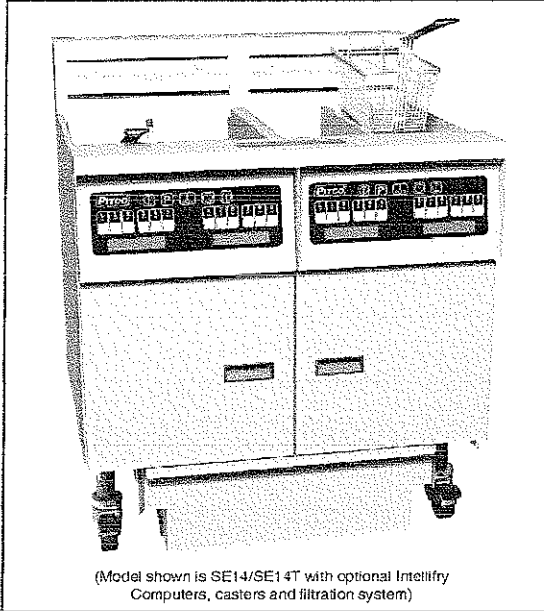

(Model shown is SE14/SE14T with optional Intellifry Computers, casters and filtration system)

STANDARD SPECIFICATIONS

CONSTRUCTION

- Build a Solstice Electric fryer system in any combination of full tank and twin tank fryers with "filter drawer" filtration system. Combinations without filtration or single fryers also available
- Welded tank with an extra smooth peened finish ensures easy cleaning
- Immersion type; sealed construction heating elements with high temperature alloy stainless steel sheath
- Solstice Electric fryers are designed with a fixed heating element to eliminate oil migration through pivot components. This design creates a safer working environment by keeping the hot elements in the tank where they belong.
- When used with a filtration system, fryers are available in combinations of two or more units
- Stainless steel front, door, side panels and splashback
- Heavy duty 3/16" (48 cm) door hinge

CONTROLS

- Solid State controller maintains the fryer temperature between 250°F (122°C) and 380°F (193°C). Solid State controller has built-in melt cycle and boil-out capability
- Temperature limit switch safely shuts off the fryer if the oil temperature exceeds the upper limit
- Drain valve interlock switch shuts disables the fryer if the drain is opened preventing accidental fires. The hermetically sealed proximity switch has no moving parts to get contaminated with grease.

STANDARD ACCESSORIES

- Solid State Control
- Baskets (Twin Size)
- Lift off basket hangers
- 9" adjustable legs
- Stainless steel tank, front, door and sides
- Drain Valve Interlock
- Tank racks
- Clean out rod
- Fryer cleaning brush

AVAILABLE OPTIONS & ACCESSORIES

- Digital controller
- Intellifry computer
- Solid state back-up control*
- Filter drawer system (for 2 or more fryers)
- Filter system heat tape (for use with solid shortening)
- 9" adjustable casters
- Basket lifts**
- Stainless steel back
- Stainless steel tank covers
- Bread and Batter cabinet
- Flush hose
- Filter powder
- Filter paper

OPTIONAL FILTER SYSTEM

(Available on 2 or more units)

- Filter drawer glides on self aligning roller-less guides
- 1-1/4" NPT drain valve for quick draining on both full and twin tanks
- Easy to remove filter unit for fast cleaning and paper replacement
- Filter piping integrated into the fryer for no-hassle filtering
- Extra large 3" drain manifold to prevent clogging

APPROVALS

- UL Certified
- CUL Certified
- NSF Listed
- CE Certified



* Solid state control equipped with melt cycle and boil-out, and can be used as back-up in combination with the Intellifry or Digital controls

** Basket lifts to be used in combination with Intellifry or Digital control

Patent Pending

Pitco Frialator, Inc. P.O. Box 501, Concord NH 03302-0501 • 509 Route 3A Bow NH 03304 USA
(603) 225-6684 • Fax (603) 225-8472 • www.pitco.com



L10-146 Rev 2 (05/03)



Model SE14, SE14T & SE18 Solstice Electric Series Fryers

Model SE14, SE14T & SE18 Solstice Electric Series Fryers

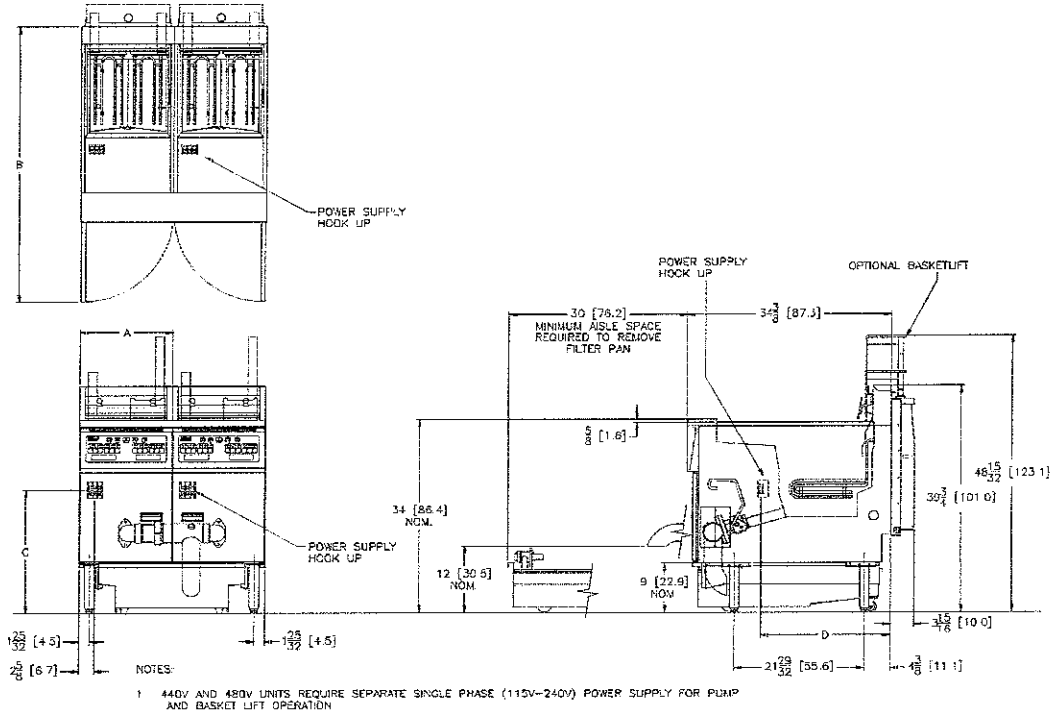

ELECTRICAL REQUIREMENTS																		
FILTER PUMP	VOLTS/FREQ	AMPS	HEAT TAPE	CONTROL TYPE	AMPS													
					115V 50/60HZ	200,208V 60/60HZ	220,230,240V 50/60HZ	440-480V 50/60HZ										
8.0GPM (30.3LPM) 1/3HP	115/60	6.8	0.9	SOLID STATE DIGITAL I-12 COMPUTER	0.2	0.1	0.1	0.1	STANDARD									
8.0GPM (30.3LPM) 1/3HP	200-208/60	3.1	0.5		0.2	0.1	0.1	0.1	OPTIONAL									
6.7GPM (25.4LPM) 1/3HP	200-208/50	3.8	0.5	I-12 COMPUTER	0.2	0.1	0.1	0.1	OPTIONAL									
8.0GPM (30.3LPM) 1/3HP	220-230/60	2.8	0.5		0.2	0.1	0.1	0.1	OPTIONAL									
6.7GPM (25.4LPM) 1/3HP	220-230/50	3.4	0.5	BASKET LIFT	0.7	0.4	0.4	N/A	OPTIONAL									
8.0GPM (30.3LPM) 1/3HP	240/60	3.5	0.5															
6.7GPM (25.4LPM) 1/3HP	240/50	3.5	0.5															
	VOLTS/PHASE	200/1	208/1	220/1	230/1	240/1	440/1	480/1	200/3	208/3	220/3	240/3	440/3	480/3	346V/200/3	380V/220/3	400V/230/3	415V/240/3
17kW SE14/SE14T/SE18	AMPS PER PHASE	78.6 (15.7kW)	61.7	77.3	73.9	70.8	32.5 (11.3kW)	35.4	45.4 (13.7kW)	47.2	44.6	40.9	18.7 (14.3kW)	20.4	26.2 (12.9kW)	25.8	24.5	23.7
22kW SE14R/SE14TR/SE18R	AMPS PER PHASE	101.7 (20.3kW)	105.8	100.0	95.7	91.7	42.0 (15.1kW)	45.8	58.7 (20.9kW)	61.1	57.7	52.9	24.3 (18.8kW)	26.5	33.9 (20.2kW)	33.4	31.8	30.6

DIMENSIONS AND CAPACITIES						
MODEL	DIM A	DIM B	DIM C	DIM D	OIL CAPACITY	COOK AREA
SE14/SE14R	15 1/2 [39.7]	48 3/4 [122.7]	21 1/2 [54.9]	21 1/2 [55.4]	40-50 LBS [18-23 KG]	14 x 14 1/2 x 4 [35.6 x 36.3 x 10.2]
SE14T/SE14TR	15 1/2 [39.7]	48 3/4 [122.7]	21 1/2 [54.9]	21 1/2 [55.4]	20-25 LBS [9-11.5 KG]	7 x 14 1/2 x 4 [17.8 x 36.3 x 10.2]
SE18/SE18R	19 1/2 [49.9]	52 1/2 [132.9]	20 5/8 [52.4]	24 1/2 [63.1]	70-90 LBS [32-41 KG]	18 x 18 1/2 x 4 1/4 [45.7 x 46.5 x 12.1]

SHORT FORM SPECIFICATIONS
Provide Pitco Model SE electric fryer. Fryer shall have immersion type heating elements with high temperature alloy stainless steel sheath. Fryer shall have high input elements. Fryer temperature control shall consist of a solid state thermostat with melt cycle. Fryer shall have a deep cool zone; minimum 20% of total oil capacity to trap burnt particles, crumbs and black specks. Provide accessories as follows:

TYPICAL APPLICATION
Frying a wide variety of foods in a limited amount of space. Frying that requires a high volume production rate.



Pitco Frialator, Inc. P.O. Box 501 Concord, NH 03302-0501 • 509 Route 3A, Bow NH 03304 USA
(603) 225-6684 • Fax (603) 225-8472 • www.pitco.com

L10-146 Rev 2 (05/03) Specifications subject to change without notice

Printed in the USA



Model P14, P18, P24, P34
Portable Filter System

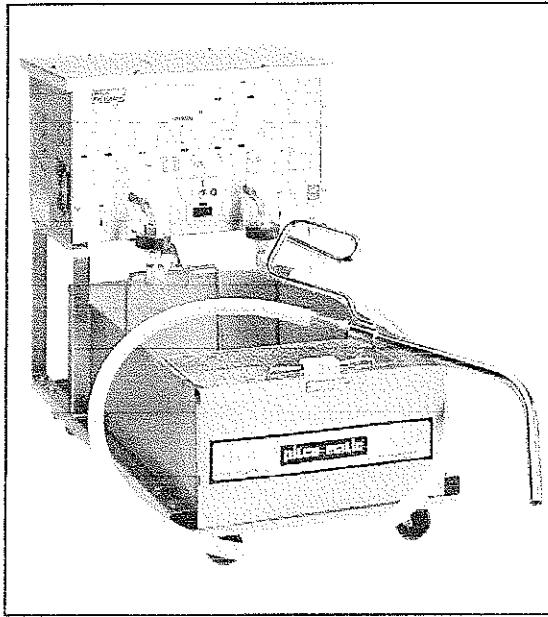

Project _____

Item No _____

Quantity _____

Model P14, P18, P24, P34 Portable Filter System

STANDARD SPECIFICATIONS

CONSTRUCTION

- Filter pan and pump assembly enclosure are constructed of polished stainless steel.
- All other surfaces are nickel plated finish
- Welded steel frame mounted on four ball-bearing swivel casters for easy movement
- 1/3 HP heavy duty motor and pump assembly
- 5 foot (1.5 meter) flexible, sanitary high temperature return hose equipped with nozzle.
- Return hose nozzle is nickel plated steel with a non-heat conducting handle
- Extra large filter area for large fryer filtering
- Heater to soften solid shortening for quicker filter start-up (optional)

CONTROLS

- ON/OFF/HEATER ON switch for operating pump

OPERATIONS

- Four swivel caster design allows for easy movement and storage of the filter
- Quick disconnect hose connections make it easy to assemble and disassemble
- Low profile allows for easy placement under the fryer drain
- Easy to remove filter media assembly for quick and easy filter paper replacement
- Lift out filter pan for easy cleaning

STANDARD ACCESSORIES

- 10 Foot (3.05 meters) oil proof supply cord
- Filter Pan
- Filter catch basket
- 25 sheets of heavy duty filter paper (flat)
- Sample filter powder packets
- 1 sediment clean out scoop
- 1 - 7 inch (17.8 cm.) drain nipple

AVAILABLE OPTIONS & ACCESSORIES

- Filter heater (for solid shortening use)
- Filter powder packets
- Filter paper (flat)
- Cover

APPROVALS

- CSA Certified (AGA, CGA)
- NSF Listed
- MEA Approved
- CE Certified
- UL Listed



Patent Pending

Pitco Frialator, Inc. P.O. Box 501, Concord NH 03302-0501 • 509 Route 3A Bow NH 03304 USA
(603) 225-6684 • Fax (603) 225-8472 • www.pitco.com



L10-037 Rev 7 (03/03)



Model P-14, P-18, P-24, P-34 Portable Filter System

Model P14, P18, P24, P34 Portable Filter System

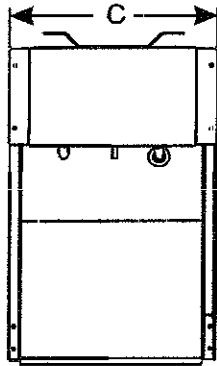

If you have: (Fryer Model #)	You need: (Filter Model #)
14, 14R, 14T, 35C+, 45C+	P14
18, SE18R	P18
20F, 20P	P24
24P, 24F, 24FF	P24
34P, 34F, 34FF	P34

* Models 20F, 26F(FF) & 34F(FF) must have 8" legs or casters.

NOTE: Model numbers above represent both gas and electric units unless otherwise indicated (i.e. Both Model SG14 and Model SE14 use the P14 filter)

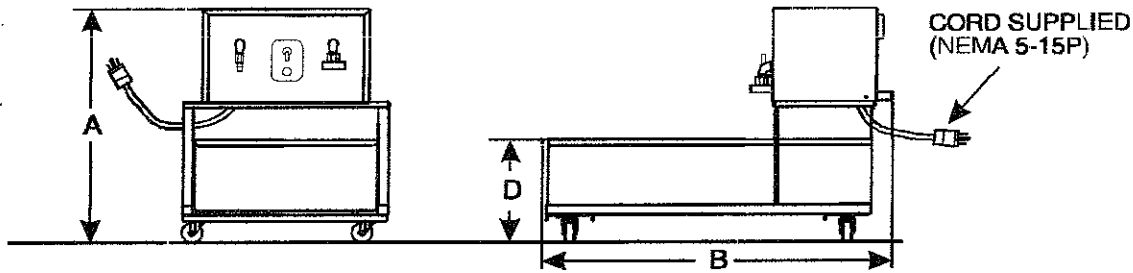

DIMENSIONS					PAN CAPACITY & SHIPPING INFORMATION		
MODEL	LETTERED DIMENSIONS				MODEL	Pan Capacity	Shipping Information
	A	B	C	D			
P-14	24 in (61 cm)	30 in (76.2 cm)	17 in (43.2 cm)	10-1/2 in (28 cm)	P-14	55 lbs (24.9 Kg)	131 lbs (59.4 Kg.) 10 cu. ft (0.28 cu. meters)
P-18	24 in (61 cm)	34 in (86.4 cm)	20-1/4 in (51.4 cm)	10-1/2 in (28 cm)	P-18	75 lbs (34.0 Kg.)	150 lbs (68.0 Kg.) 14 cu. ft (0.40 cu. meters)
P-24	26 in (66 cm)	42 in (106.7 cm)	20-1/4 in (51.4 cm)	12-1/2 in (33 cm)	P-24	160 lbs (72.6 Kg.)	181 lbs (82.1 Kg.) 18 cu. ft (0.51 cu. meters)
P-34	29 in (73.7 cm)	42 in (106.7 cm)	20-1/4 in (51.4 cm)	15-1/2 in (40.6 cm)	P-34	210 lbs (95.3 Kg.)	206 lbs (93.4 Kg.) 20 cu. ft (0.57 cu. meters)

PERFORMANCE CHARACTERISTICS	ELECTRICAL
Pumps up to 5.6 gallons (21.2 liters) per minute	120 VAC / 60 Hz / 10 AMP 220/240 VAC / 50 Hz / 4 AMP

SHORT FORM SPECIFICATION

Provide Pitco Model P ____ (14, 18, 24, 34) Portable Filter System. Unit shall have the ability to receive oil gravity drained from fryers. Model P-14 shall have 300 square inches (1,936 square cm) of filter area. Models P-18, 24 & 34 shall have 450 square inches (2,903 square cm) of filter area. Unit shall have a polished stainless steel filter pan and pump enclosure; all other surfaces to be nickel plated. Provide accessories as follows:

TYPICAL APPLICATION

Mobile filtering of all of your frying appliances. Filter can be used with gravity drain fryers.



Pitco Frialator, Inc., P.O. Box 501 Concord, NH 03302-0501 • 509 Route 3A, Bow NH 03304 USA
(603) 225-6634 • Fax (603) 225-8472 • www.pitco.com

L10-037 Rev 7 (08/03) Specifications subject to change without notice

Printed in the USA