



State of West Virginia
 Department of Administration
 Purchasing Division
 2019 Washington Street East
 Post Office Box 50130
 Charleston, WV 25305-0130

Request for Quotation

RFQ NUMBER
COR61335

PAGE
1

ADDRESS CORRESPONDENCE TO ATTENTION OF
JOHN ABBOTT
304-558-2544

RFQ COPY

TYPE NAME/ADDRESS HERE
 *116142806 304-340-0220
 C&T Design and Equip. Co., Inc.
 1415 Stonehenge Road
 Charleston, WV 25314
 WV 032078

SHIP TO

DIVISION OF CORRECTIONS
 617 LEON SULLIVAN WAY
 CHARLESTON, WV
 25301 304-558-8045

DATE PRINTED 02/14/2007	TERMS OF SALE	SHIP VIA	F.O.B. destination	FREIGHT TERMS included
BID OPENING DATE: 03/07/2007		BID OPENING TIME 01:30PM		

LINE	QUANTITY	UOP	CAT NO	ITEM NUMBER	UNIT PRICE	AMOUNT
				ADDENDUM #01		
				THIS ADDENDUM IS ISSUED TO CANCEL THE PRE-BID MEETING TO BE HELD ON 2/23/2007. THE REASON FOR THE CANCELLATION IS THAT THE KITCHEN AREA IS CURRENTLY UNDER RENOVATION AND NOT AVAILABLE FOR INSPECTION.		
				SUCCESSFUL BIDDER WILL DELIVER, UN-CRATE, ASSEMBLE, SET IN PLACE AND ANCHOR TO THE FLOOR - ALL CONNECTIONS WILL BE COMPLETED AT A LATER TIME BY CORRECTION'S STAFF		
				DUE TO CURRENT RENOVATIONS AND EXACT UNKNOWN DATE OF COMPLETION, VENDOR WILL DELIVER UPON NOTIFICATION OF GROVER ROSENCRANCE, ASSOCIATE WARDEN. PLEASE LIST POINT OF CONTACT WITH PHONE NUMBER(S). ANTICIPATED RENOVATION COMPLETION DATE IS 5/15/2007.		
				ALL EQUIPMENT-AS SPECIFIED		\$81,277.00

RECEIVED
 2007 MAR -7 P 12:41
 PURCHASING DIVISION
 STATE OF WV

SEE REVERSE SIDE FOR TERMS AND CONDITIONS

SIGNATURE *Mark D Helms* TELEPHONE 304-340-0220 DATE 3-07-07

TITLE Sales Consultant FEIN 35-1315249 ADDRESS CHANGES TO BE NOTED ABOVE

WHEN RESPONDING TO RFQ, INSERT NAME AND ADDRESS IN SPACE ABOVE LABELED 'VENDOR'



State of West Virginia
 Department of Administration
 Purchasing Division
 2019 Washington Street East
 Post Office Box 50130
 Charleston, WV 25305-0130

Request for Quotation

RFQ NUMBER
COR61335

PAGE
1

ADDRESS CORRESPONDENCE TO ATTENTION OF
JOHN ABBOTT
304-558-2544

RFQ COPY

TYPE NAME/ADDRESS HERE

*116142806 304-340-0220
 C&T Design and Equip.Co., Inc
 1415 Stonehenge Road
 Charleston, WV 25314

WV032078

DIVISION OF CORRECTIONS

617 LEON SULLIVAN WAY

CHARLESTON, WV

25301

304-558-8045

VENDOR

SHIP TO

DATE PRINTED	TERMS OF SALE	SHIP VIA	F.O.B.	FREIGHT TERMS
02/07/2007			destination	included
BID OPENING DATE: 03/07/2007		BID OPENING TIME 01:30PM		

LINE	QUANTITY	UOP	CAT NO.	ITEM NUMBER	UNIT PRICE	AMOUNT
REQUEST FOR QUOTATION						
THE PURCHASING DIVISION IS SOLICITING BIDS FOR THE HUTTONSVILLE CORRECTIONAL CENTER TO PROVIDE THE INSTALLATION OF CAFETERIA / KITCHEN EQUIPMENT.						
MANDATORY ON-SITE PRE-BID: 2/23/2007; 2:00 PM						
ATTACHMENTS: 1. SPECIFICATIONS 2. AFFIDAVIT						
IF AN EQUAL BRAND & MODEL IS BID, SPECIFICATION DOCUMENTATION AND A COLORED BROCHURE SHALL BE SUBMITTED WITH THE BID.						
PLEASE CONTACT GROVER ROSENCRANCE TWO DAYS PRIOR TO THE PRE-BID DATE TO PRE-REGISTER FOR THE PRE-BID; AT 304-335-2291.						
0001	1	LS		931-30		\$81,277.00
CAFETERIA / KITCHEN EQUIPMENT						
EXHIBIT 5						
NOTICE TO PROCEED: THIS CONTRACT IS TO BE PERFORMED WITHIN 60 CALENDAR DAYS AFTER THE NOTICE TO PROCEED IS RECEIVED. UNLESS OTHERWISE SPECIFIED, THE FULLY EXECUTED PURCHASE ORDER WILL BE CONSIDERED NOTICE TO						

SEE REVERSE SIDE FOR TERMS AND CONDITIONS

SIGNATURE	TELEPHONE	DATE
<i>Mark Holmes</i>	304-340-0220	3-07-07
TITLE	FEIN	ADDRESS CHANGES TO BE NOTED ABOVE
Sales Consultant	35-1315249	

WHEN RESPONDING TO RFQ, INSERT NAME AND ADDRESS IN SPACE ABOVE LABELED 'VENDOR'



State of West Virginia
 Department of Administration
 Purchasing Division
 2019 Washington Street East
 Post Office Box 50130
 Charleston, WV 25305-0130

Request for Quotation

RFQ NUMBER
CR61335

PAGE
2

ADDRESS CORRESPONDENCE TO ATTENTION OF
JOHN ABBOTT
304-558-2544

RFQ COPY
 TYPE NAME/ADDRESS HERE

VENDOR

SHIP TO

DIVISION OF CORRECTIONS
617 LEON SULLIVAN WAY
CHARLESTON, WV
25301 304-558-8045

DATE PRINTED 02/07/2007	TERMS OF SALE	SHIP VIA	F.O.B.	FREIGHT TERMS
-----------------------------------	---------------	----------	--------	---------------

BID OPENING DATE: **03/07/2007** BID OPENING TIME **01:30PM**

LINE	QUANTITY	UOP	CAT NO.	ITEM NUMBER	UNIT PRICE	AMOUNT
<p>PROCEED.</p> <p>CANCELLATION: THE DIRECTOR OF PURCHASING RESERVES THE RIGHT TO CANCEL THIS CONTRACT IMMEDIATELY UPON WRITTEN NOTICE TO THE VENDOR IF THE MATERIALS OR WORKMANSHIP SUPPLIED ARE OF AN INFERIOR QUALITY OR DO NOT CONFORM WITH THE SPECIFICATIONS OF THE BID AND CONTRACT HERE IN.</p> <p>WAGE RATES: THE CONTRACTOR OR SUBCONTRACTOR SHALL PAY THE HIGHER OF THE U.S. DEPARTMENT OF LABOR MINIMUM WAGE RATES AS ESTABLISHED FOR RANDOLPH COUNTY, PURSUANT TO WEST VIRGINIA CODE 21-5A, ET, SEQ. (PREVAILING WAGE RATES APPLY TO THIS PROJECT)</p> <p>ARBITRATION: ANY REFERENCES MADE TO ARBITRATION OR INTEREST FOR PAYMENTS DUE (EXCEPT FOR ANY INTEREST REQUIRED BY STATE LAW) CONTAINED IN THIS CONTRACT OR IN ANY AMERICAN INSTITUTE OF ARCHITECTS DOCUMENTS PERTAINING TO THIS CONTRACT ARE HEREBY DELETED.</p> <p>WORKERS' COMPENSATION: VENDOR IS REQUIRED TO PROVIDE A CERTIFICATE FROM WORKERS' COMPENSATION IF SUCCESSFUL.</p> <p>ALL OF THE ITEMS CHECKED BELOW WILL BE A REQUIREMENT OF THIS CONTRACT:</p> <p>(XX) INSURANCE: SUCCESSFUL VENDOR SHALL FURNISH PROOF OF COMMERCIAL GENERAL LIABILITY INSURANCE PRIOR TO ISSUANCE OF CONTRACT. UNLESS OTHERWISE SPECIFIED IN THE BID DOCUMENTS, THE MINIMUM AMOUNT OF INSURANCE COVERAGE REQUIRED IS \$250,000.</p> <p>() BUILDERS RISK INSURANCE: SUCCESSFUL VENDOR SHALL FURNISH PROOF OF BUILDERS RISK - ALL RISK INSURANCE IN AN AMOUNT EQUAL TO 100% OF THE AMOUNT OF THE CONTRACT.</p>						

SEE REVERSE SIDE FOR TERMS AND CONDITIONS

SIGNATURE	TELEPHONE	DATE
TITLE	FEIN	ADDRESS CHANGES TO BE NOTED ABOVE

WHEN RESPONDING TO RFQ, INSERT NAME AND ADDRESS IN SPACE ABOVE LABELED 'VENDOR'



State of West Virginia
 Department of Administration
 Purchasing Division
 2019 Washington Street East
 Post Office Box 50130
 Charleston, WV 25305-0130

Request for Quotation

RFQ NUMBER
CDR61335

PAGE
3

ADDRESS CORRESPONDENCE TO ATTENTION OF
JOHN ABBOTT
304-558-2544

VENDOR

RFQ COPY
 TYPE NAME/ADDRESS HERE

SHIP TO

DIVISION OF CORRECTIONS
 617 LEON SULLIVAN WAY
 CHARLESTON, WV
 25301 304-558-8045

DATE PRINTED 02/07/2007	TERMS OF SALE	SHIP VIA	F.O.B.	FREIGHT TERMS
-----------------------------------	---------------	----------	--------	---------------

BID OPENING DATE: **03/07/2007** BID OPENING TIME **01:30PM**

LINE	QUANTITY	UOP	CAT NO.	ITEM NUMBER	UNIT PRICE	AMOUNT
<p>(XX) BONDS: FIVE PERCENT (5%) OF THE TOTAL AMOUNT OF THE BID PAYABLE TO THE STATE OF WEST VIRGINIA, SHALL BE SUBMITTED WITH EACH BID AS A BID BOND. THE SUCCESSFUL BIDDER SHALL ALSO FURNISH A PERFORMANCE BOND AND LABOR/MATERIAL BOND FOR 100% OF THE AMOUNT OF THE CONTRACT. BONDS MAY BE PROVIDED IN THE FORM OF A CERTIFIED CHECK, IRREVOCABLE LETTER OF CREDIT, OR BOND FURNISHED BY A SOLVENT SURETY COMPANY AUTHORIZED TO DO BUSINESS IN THE STATE OF WEST VIRGINIA. A LETTER OF CREDIT SUBMITTED IN LIEU OF A PERFORMANCE AND LABOR & MATERIAL BOND WILL ONLY BE ALLOWED FOR PROJECTS UNDER \$100,000. PERSONAL OR BUSINESS CHECKS ARE NOT ACCEPCTABLE IN LIEU OF THE 5% BID BOND, PERFORMANCE BOND, OR LABOR AND MATERIAL BOND.</p> <p>() MAINTENANCE BOND: A TWO (2) YEAR MAINTENANCE BOND COVERING THE ROOFING SYSTEM WILL BE A REQUIREMENT OF THE SUCCESSFUL VENDOR.</p> <p>REV. 11/00</p> <p>EXHIBIT 7</p> <p>DOMESTIC ALUMINUM, GLASS & STEEL IN PUBLIC WORKS PROJECTS</p> <p>IN ACCORDANCE WITH WEST VIRGINIA CODE 5-19-1 ET., SEQ., EVERY CONTRACT FOR CONSTRUCTION, RECONSTRUCTION, ALTERATION, REPAIR, IMPROVEMENT OR MAINTENANCE OF PUBLIC WORKS, WHERE THE COST IS MORE THAN \$50,000 AND, IN THE CASE OF STEEL ONLY, WHERE THE COST OF STEEL IS MORE THAN \$50,000 OR WHERE MORE THAN 10,000 POUNDS OF STEEL ARE REQUIRED, THE STATE WILL ACCEPT ONLY ALUMINUM GLASS, OR STEEL PRODUCTS PRODUCED IN THE UNITED STATES</p>						

SEE REVERSE SIDE FOR TERMS AND CONDITIONS

SIGNATURE	TELEPHONE	DATE
-----------	-----------	------

TITLE	FEIN	ADDRESS CHANGES TO BE NOTED ABOVE
-------	------	-----------------------------------

WHEN RESPONDING TO RFQ, INSERT NAME AND ADDRESS IN SPACE ABOVE LABELED 'VENDOR'



State of West Virginia
 Department of Administration
 Purchasing Division
 2019 Washington Street East
 Post Office Box 50130
 Charleston, WV 25305-0130

Request for Quotation

RFQ NUMBER
COR61335

PAGE
4

ADDRESS CORRESPONDENCE TO ATTENTION OF:
JOHN ABBOTT
304-558-2544

VENDOR

RFQ COPY
 TYPE NAME/ADDRESS HERE

SHIP TO

DIVISION OF CORRECTIONS
 617 LEON SULLIVAN WAY
 CHARLESTON, WV
 25301 304-558-8045

DATE PRINTED	TERMS OF SALE	SHIP VIA	F.O.B.	FREIGHT TERMS
02/07/2007				

BID OPENING DATE: **03/07/2007** BID OPENING TIME: **01:30PM**

LINE	QUANTITY	UOP	CAT NO	ITEM NUMBER	UNIT PRICE	AMOUNT
<p>IN ADDITION, ITEMS OF MACHINERY OR EQUIPMENT PURCHASED FOR USE AT THE SITE OF PUBLIC WORKS SHALL BE MADE OF DOMESTIC ALUMINUM, GLASS OR STEEL, UNLESS THE COST OF THE PRODUCT IS LESS THAN \$50,000 OR LESS THAN 10,000 POUNDS OF STEEL ARE USED IN PUBLIC WORKS PROJECTS.</p> <p>FOREIGN MADE ALUMINUM, GLASS OR STEEL PRODUCTS MAY BE ACCEPTED ONLY IF THE COST OF DOMESTIC PRODUCTS IS FOUND TO BE UNREASONABLE. SUCH COST IS UNREASONABLE IF IT IS 20% OR MORE HIGHER THAN THE BID PRICE FOR FOREIGN MADE PRODUCTS. IF THE DOMESTIC ALUMINUM, GLASS OR STEEL PRODUCTS TO BE SUPPLIED OR PRODUCED IN A "SUBSTANTIAL LABOR SURPLUS AREA", AS DEFINED BY THE UNITED STATES DEPARTMENT OF LABOR, FOREIGN PRODUCTS MAY BE SUPPLIED ONLY IF DOMESTIC PRODUCTS ARE 30% OR MORE HIGHER IN PRICE THAN THE FOREIGN MADE PRODUCTS.</p> <p>IF, PRIOR TO THE AWARD OF A CONTRACT UNDER THE ABOVE PROVISIONS, THE SPENDING OFFICER OF THE SPENDING UNIT DETERMINES THAT THERE EXISTS A BID FOR LIKE FOREIGN ALUMINUM, GLASS OR STEEL THAT IS REASONABLE AND LOWER THAN THE LOWEST BID DOMESTIC PRODUCTS, THE SPENDING OFFICE MAY REQUEST, IN WRITING, A REEVALUATION AND REDUCTION IN THE LOWEST BID FOR SUCH DOMESTIC PRODUCTS ALL VENDORS MUST INDICATE IN THEIR BID IF THEY ARE SUPPLYING FOREIGN ALUMINUM, GLASS OR STEEL.</p> <p>REV. 3/88</p> <p>EXHIBIT 9</p> <p>NOTICE FOR ISSUANCE & ACKNOWLEDGEMENT OF CONSTRUCTION PROJECT ADDENDA</p> <p>THE ARCHITECT/ENGINEER AND/OR AGENCY SHALL BE REQUIRED</p>						

SEE REVERSE SIDE FOR TERMS AND CONDITIONS.

SIGNATURE	TELEPHONE	DATE
TITLE	FEIN	ADDRESS CHANGES TO BE NOTED ABOVE

WHEN RESPONDING TO RFQ, INSERT NAME AND ADDRESS IN SPACE ABOVE LABELED 'VENDOR'



State of West Virginia
 Department of Administration
 Purchasing Division
 2019 Washington Street East
 Post Office Box 50130
 Charleston, WV 25305-0130

Request for Quotation

RFQ NUMBER
CR61335

PAGE
5

ADDRESS CORRESPONDENCE TO ATTENTION OF:
JOHN ABBOTT
304-558-2544

RFQ COPY
 TYPE NAME/ADDRESS HERE

VENDOR

SHIP TO

DIVISION OF CORRECTIONS
617 LEON SULLIVAN WAY
CHARLESTON, WV
25301 304-558-8045

DATE PRINTED 02/07/2007	TERMS OF SALE	SHIP VIA	F.O.B.	FREIGHT TERMS
-----------------------------------	---------------	----------	--------	---------------

BID OPENING DATE: **03/07/2007** BID OPENING TIME **01:30PM**

LINE	QUANTITY	UOP	CAT NO.	ITEM NUMBER	UNIT PRICE	AMOUNT
<p>TO ABIDE BY THE FOLLOWING SCHEDULE IN ISSUING CONSTRUCTION PROJECT ADDENDA FOR STATE AGENCIES:</p> <p>(1) THE ARCHITECT/ENGINEER SHALL PREPARE THE ADDENDUM AND A LIST OF ALL PARTIES THAT HAVE PROCURED DRAWINGS AND SPECIFICATIONS FOR THE PROJECT. THE ADDENDUM AND LIST SHALL BE FORWARDED TO THE BUYER IN THE STATE PURCHASING DIVISION. THE ARCHITECT/ENGINEER SHALL ALSO SEND A COPY OF THE ADDENDUM TO THE STATE AGENCY FOR WHICH THE CONTRACT IS ISSUED.</p> <p>(2) THE BUYER SHALL SEND THE ADDENDUM TO ALL INTERESTED PARTIES AND, IF NECESSARY, EXTEND THE BID OPENING DATE. ANY ADDENDUM SHOULD BE RECEIVED BY THE BUYER WITHIN FOURTEEN (14) DAYS PRIOR TO THE BID OPENING DATE.</p> <p>(3) ALL ADDENDA SHOULD BE FORMALLY ACKNOWLEDGED BY ALL BIDDERS AND SUBMITTED TO THE STATE PURCHASING DIVISION. THE SAME RULES AND REGULATIONS THAT APPLY TO THE ORIGINAL BIDDING DOCUMENT SHALL ALSO APPLY TO AN ADDENDUM DOCUMENT. THE ONLY EXCEPTION MAY BE FOR AN ADDENDUM THAT IS ISSUED FOR THE SOLE PURPOSE OF CHANGING A BID OPENING TIME AND/OR DATE.</p> <p>REV. 11/96</p> <p>EXHIBIT 10</p> <p>ADDENDUM ACKNOWLEDGEMENT</p> <p>I HEREBY ACKNOWLEDGE RECEIPT OF THE FOLLOWING CHECKED ADDENDUM(S) AND HAVE MADE THE NECESSARY REVISIONS TO MY PROPOSAL, PLANS AND/OR SPECIFICATION, ETC.</p>						

SEE REVERSE SIDE FOR TERMS AND CONDITIONS

SIGNATURE	TELEPHONE	DATE
TITLE	FEIN	ADDRESS CHANGES TO BE NOTED ABOVE

WHEN RESPONDING TO RFQ, INSERT NAME AND ADDRESS IN SPACE ABOVE LABELED 'VENDOR'



State of West Virginia
 Department of Administration
 Purchasing Division
 2019 Washington Street East
 Post Office Box 50130
 Charleston, WV 25305-0130

Request for Quotation

RFQ NUMBER
COR61335

PAGE
6

ADDRESS CORRESPONDENCE TO ATTENTION OF
JOHN ABBOTT
304-558-2544

VENDOR

RFQ COPY
 TYPE NAME/ADDRESS HERE
 *116142806 304-340-0220
 C&T Design and Equip. Co., Inc.
 1415 Stonehenge Road
 Charleston, WV 25314
 WV 032078

SHIP TO

DIVISION OF CORRECTIONS
 617 LEON SULLIVAN WAY
 CHARLESTON, WV
 25301 304-558-8045

DATE PRINTED 02/07/2007	TERMS OF SALE	SHIP VIA	F.O.B. destination	FREIGHT TERMS included
-----------------------------------	---------------	----------	-----------------------	---------------------------

BID OPENING DATE: **03/07/2007** BID OPENING TIME **01:30PM**

LINE	QUANTITY	UQP	CAT NO	ITEM NUMBER	UNIT PRICE	AMOUNT
ADDENDUM NOS.:						
NO. 1			2-14-07			
NO. 3						
NO. 4						
NO. 5						
I UNDERSTAND THAT FAILURE TO CONFIRM THE RECEIPT OF THE ADDENDUM(S) MAY BE CAUSE FOR REJECTION OF THE BIDS.						
..... <i>Mark D. Holmes</i>SIGNATURE						
.....C&T Design and Equip. Co., Inc. COMPANY						
.....3-07-07.....DATE						
REV. 11/96						
CONTRACTORS LICENSE						
WEST VIRGINIA STATE CODE 21-11-2 REQUIRES THAT ALL PERSONS DESIRING TO PERFORM CONTRACTING WORK IN THIS STATE MUST BE LICENSED. THE WEST VIRGINIA CONTRACTORS LICENSING BOARD IS EMPOWERED TO ISSUE THE CONTRACTORS LICENSE. APPLICATIONS FOR A CONTRACTORS LICENSE MAY BE MADE BY CONTACTING THE WEST VIRGINIA DIVISION OF LABOR CAPITOL COMPLEX, BUILDING 3, ROOM 319, CHARLESTON, WV 25305. TELEPHONE: (304) 558-7890.						

SEE REVERSE SIDE FOR TERMS AND CONDITIONS

SIGNATURE <i>Mark D. Holmes</i>	TELEPHONE 304-340-0220	DATE 3-07-07
TITLE Sales Consultant	FEIN 35-1315249	ADDRESS CHANGES TO BE NOTED ABOVE

WHEN RESPONDING TO RFQ, INSERT NAME AND ADDRESS IN SPACE ABOVE LABELED 'VENDOR'



State of West Virginia
 Department of Administration
 Purchasing Division
 2019 Washington Street East
 Post Office Box 50130
 Charleston, WV 25305-0130

Request for Quotation

RFQ NUMBER
COR61335

PAGE
7

ADDRESS CORRESPONDENCE TO ATTENTION OF
JOHN ABBOTT
304-558-2544

RFQ COPY

VENDOR

TYPE NAME/ADDRESS HERE
 *116142806 304-340-0220
 C&T Design and Equip. Co., Inc.
 1415 Stonehenge Road
 Charleston, WV 25314
 WVO32078

SHIP TO

DIVISION OF CORRECTIONS
 617 LEON SULLIVAN WAY
 CHARLESTON, WV
 25301 304-558-8045

DATE PRINTED 02/07/2007	TERMS OF SALE	SHIP VIA	F.O.B.	FREIGHT TERMS
			destination	included
BID OPENING DATE: 03/07/2007		BID OPENING TIME 01:30PM		

LINE	QUANTITY	UOP	CAT NO	ITEM NUMBER	UNIT PRICE	AMOUNT	
<p>WEST VIRGINIA STATE CODE 21-11-11 REQUIRES ANY PROSPECTIVE BIDDER TO INCLUDE THE CONTRACTORS LICENSE NUMBER ON THEIR BID.</p> <p>BIDDER TO COMPLETE:</p> <p>CONTRACTORS NAME: ... C&T Design and Equip. Co., Inc. ...</p> <p>CONTRACTORS LICENSE NO.: WVO32078</p> <p>THE SUCCESSFUL BIDDER WILL BE REQUIRED TO FURNISH A COPY OF THEIR CONTRACTORS LICENSE PRIOR TO ISSUANCE OF A PURCHASE ORDER/CONTRACT</p> <p>APPLICABLE LAW</p> <p>THE WEST VIRGINIA STATE CODE, PURCHASING DIVISION RULES AND REGULATIONS, AND THE INFORMATION PROVIDED IN THE "REQUEST FOR QUOTATION" ISSUED BY THE PURCHASING DIVISION IS THE SOLE AUTHORITY GOVERNING THIS PROCUREMENT.</p> <p>ANY INFORMATION PROVIDED IN SPECIFICATION MANUALS, OR ANY OTHER SOURCE, VERBAL OR WRITTEN, WHICH CONTRADICTS OR ALTERS THE INFORMATION PROVIDED FROM THE SOURCES AS DESCRIBED IN THE ABOVE PARAGRAPH IS VOID AND OF NO EFFECT.</p> <p>BANKRUPTCY: IN THE EVENT THE VENDOR/CONTRACTOR FILES FOR BANKRUPTCY PROTECTION, THIS CONTRACT IS AUTOMATICALLY NULL AND VOID, AND IS TERMINATED WITHOUT FURTHER ORDER.</p> <p>REV. 1/2005</p>							\$\$\$\$\$

SEE REVERSE SIDE FOR TERMS AND CONDITIONS

SIGNATURE <i>Mark D Holmes</i>	TELEPHONE 304-340-0220	DATE 3-07-07
TITLE Sales Consultant	FEIN 35-1315249	ADDRESS CHANGES TO BE NOTED ABOVE

WHEN RESPONDING TO RFQ, INSERT NAME AND ADDRESS IN SPACE ABOVE LABELED 'VENDOR'



State of West Virginia
 Department of Administration
 Purchasing Division
 2019 Washington Street East
 Post Office Box 50130
 Charleston, WV 25305-0130

Request for Quotation

RFQ NUMBER
COR61335

PAGE
8

ADDRESS CORRESPONDENCE TO ATTENTION OF:
JOHN ABBOTT
304-558-2544

VENDOR ROOM

RFQ COPY
 TYPE NAME/ADDRESS HERE
 *116142806 304-340-0220
 C&T Design and Equip. Co, Inc.
 1415 Stonehenge Road
 Charleston, WV 25314
 WV032078

SHIP TO

DIVISION OF CORRECTIONS
 617 LEON SULLIVAN WAY
 CHARLESTON, WV
 25301 304-558-8045

DATE PRINTED	TERMS OF SALE	SHIP VIA	F.O.B.	FREIGHT TERMS
02/07/2007			destination	included

BID OPENING DATE: **03/07/2007** BID OPENING TIME **01:30PM**

LINE	QUANTITY	UOP	CAT NO	ITEM NUMBER	UNIT PRICE	AMOUNT
NOTICE						
A SIGNED BID MUST BE SUBMITTED TO:						
DEPARTMENT OF ADMINISTRATION PURCHASING DIVISION BUILDING 15 2019 WASHINGTON STREET, EAST CHARLESTON, WV 25305-0130						
THE BID SHOULD CONTAIN THIS INFORMATION ON THE FACE OF THE ENVELOPE OR THE BID MAY NOT BE CONSIDERED:						
SEALED BID						
BUYER: JOHN ABBOTT-----						
REQ. NO.: COR61335-----						
BID OPENING DATE: 3/7/2007-----						
BID OPENING TIME: 1:30 PM-----						
PLEASE PROVIDE A FAX NUMBER IN CASE IT IS NECESSARY TO CONTACT YOU REGARDING YOUR BID:						
-----304-340-0221-----						
PLEASE PRINT OR TYPE NAME OF PERSON TO CONTACT CONCERNING THIS QUOTE:						
-----MARK D. HOLMES-----						

SEE REVERSE SIDE FOR TERMS AND CONDITIONS

SIGNATURE <i>Mark D Holmes</i>	TELEPHONE 304-340-0220	DATE 3-07-07
TITLE Sales Consultant	FEIN 35-1315249	ADDRESS CHANGES TO BE NOTED ABOVE

WHEN RESPONDING TO RFQ, INSERT NAME AND ADDRESS IN SPACE ABOVE LABELED 'VENDOR'



State of West Virginia
 Department of Administration
 Purchasing Division
 2019 Washington Street East
 Post Office Box 50130
 Charleston, WV 25305-0130

Request for Quotation

RFQ NUMBER
COR61335

PAGE
9

ADDRESS CORRESPONDENCE TO ATTENTION OF:
JOHN ABBOTT
304-558-2544

RFQ COPY

TYPE NAME/ADDRESS HERE

*116142806 304-340-0220
 C&T Design and Equip. Co., Inc.
 1415 Stonehenge Road
 Charleston, WV 25314
 WV032078

VENDOR

SHIP TO

DIVISION OF CORRECTIONS

617 LEON SULLIVAN WAY

CHARLESTON, WV
 25301

304-558-8045

DATE PRINTED	TERMS OF SALE	SHIP VIA	F.O.B.	FREIGHT TERMS
02/07/2007			destination	included

BID OPENING DATE: **03/07/2007** BID OPENING TIME **01:30PM**

LINE	QUANTITY	UOP	CAT NO	ITEM NUMBER	UNIT PRICE	AMOUNT
------	----------	-----	--------	-------------	------------	--------

***** THIS IS THE END OF RFQ COR61335 ***** TOTAL: \$81,277.00

SEE REVERSE SIDE FOR TERMS AND CONDITIONS

SIGNATURE <i>Mark D Holmes</i>	TELEPHONE 304-340-0220	DATE 3-07-07
TITLE Sales Consultant	FEIN 35-1315249	ADDRESS CHANGES TO BE NOTED ABOVE

WHEN RESPONDING TO RFQ, INSERT NAME AND ADDRESS IN SPACE ABOVE LABELED 'VENDOR'

STATE OF WEST VIRGINIA
PURCHASE CONTINUATION SHEET

Vendor: _____

Buyer:	Page:	Requisition or P.O. No.:
32	10	COR61335
Spending Unit:		

Item	Quantity	Description	Cost
1	2 each	<p>HEATED CABINET, MOBILE Food Warming Equipment Model No. PST-20 or equal Heated cabinet, mobile, double comp't, insulated, top mounted circulating heat system w/recessed controls, s/s fixed pan slides 2.5" OC, (20) 12x20x2.5 in /Gastro-Norm pans, s/s const'n, H.D. push bars, full bumper, 5" poly casters.</p>	
	2	Two year limited parts & one-year labor warranty, standard.	
	2	20v/50-60/1ph, std.	
	2	LEVEL 2 - Security: thermostat capillary guard, plexiguard thermometer covr, thermostat retention strap, paddle latch, s/s HD hinges, tamper proof screws, top "MaxiGuard" or dr "Maxi-Slide", S/s tubular hdls, 18 ga. ext'r/20ga int'r	
2	1 each	<p>PEELER, VEGETABLE, ELECTRIC Hobart Model No. 6460c+BUILDUP or Equal Vegetable Peeler, Correctional, 50-60 lb. Potatoes in 1-3 minute cap., V-belt drive, removable, abrasive silicon carbide disc and lexan liner, welded s/s construction, lockable controls, tamper resistant fasteners, 1 hp.</p>	
	1	1-Year parts, labor & travel time during normal working hours w/in theUSA.	
	1	6460C-ELE00E 200-230/60/1	
	1	6460C-SWIT04 4 minute timer switch 1 ph only	
	1	6460C-SWP0RH Switch on RH side	
	1	6460C-LOCYES W/lockable controls	
	1	6460C-CBTSSST Cabinet, base and trap - s/s strainer	
3	1 each	<p>GRIDDLE, COUNTER UNIT, ELECTRIC Hobart Model No. CG59-1 or Equal Griddle, Counter Unit, Elec., 72" w x 24" d x 1/2" thick smooth polished steel griddle plate, thermostats @ 12" zones, s/s heating elements, front grease trough, 3" h back splash, s/s exterior, 208/60/1 or 3 ph, 16.2 kw per connection (2)</p>	
	1	1 - Year parts, labor & travel time during normal working hours.	
	1	STAND/L-CG59 Griddle stands w/legs 72" wide	

STATE OF WEST VIRGINIA
PURCHASE CONTINUATION SHEET

Buyer: 32	Page: 11	Requisition or P O. No. COR61335
Spending Unit:		

Vendor: _____

4	2 each	<p>CONVECTION OVEN, ELECTRIC Hobart Model No. HEC502-208V or Equal Convection Oven, Elec., double-deck, std. Depth, 500 F solid state temp. cont'l, 60 minute timers, 2-speed fans, s/s front, top & sides, porcelain interior, s/s simultaneous doors w/glass, 8" s/s legs, 208v/60/1 or 3 ph, 12 kw each. PRICE TO INCLUDE CORRECTIONAL PACKAGE FOR EACH DOUBLE STACK-</p>
	2	1-Year parts, labor & travel time during normal working hours
5	1 each	<p>STEAMER, PRESSURE, DIRECT STEAM Southbend Model No. DC-3S or Equal Steamer, Pressure-Type, Direct, 3 compartments, 36" cabinet base, manual timer controls, s/s interior & exterior</p>
	1	115/60/1-ph, std.
	1	35 PSI std,
	1	Standard one year limited warranty
	1	Cabinet base doors w/locking provisions
	1	Correctional screws & tack welds
6	1 each	<p>TILTING KETTLE, DIRECT STEAM Southbend Model NO. KDL-100 or Equal Tilting Kettle, Direct, 100-gal cap., two-thirds jacket, s/s interior & exterior, s/s console w/crank tilt w/self-locking positive stop, s/s tri-leg base, 35 PSI</p>
	1	Standard one year limited warranty
	1	TVT-3 3" tangent draw off valve added to tilting kettle
	1	Correctional screws & tack welds where applicable
	1	s/s cover over control panel w/locking provisions
7	2 each	<p>FRYER, ELECTRIC Hobart Model No. 1HF85C-3 or Equal Fryer, Electric, 85 lbs., computer controls, melt cycle, single autobasket lift, s/s tank with 1 1/4" full port drain valve, s/s front & sides, 208/60/3, 24KW heating element, filter ready, on 4" legs</p>
	2	HBASKET-TWIN85 Twin Baskets HF85
	1	GRSTRIP-SPERH Banking strips
8	1 each	<p>MOBILE FILTER Hobart Model No. 85HMF-5 or Equal Mobile Filter, 100 lbs. Capacity, 208/60/1 NOTE: Please confirm voltage and basket quantity.</p>

RFQ No COR61335

AFFIDAVIT

West Virginia Code §5A-3-10a states:

No contract or renewal of any contract may be awarded by the state or any of its political subdivisions to any vendor or prospective vendor when the vendor or prospective vendor or a related party to the vendor or prospective vendor is a debtor and the debt owned is an amount greater than one thousand dollars in the aggregate

DEFINITIONS:

"Debt" means any assessment, premium, penalty, fine, tax or other amount of money owed to the state or any of its political subdivisions because of a judgment, fine, permit violation, license assessment, defaulted workers' compensation premium, penalty or other assessment presently delinquent or due and required to be paid to the state or any of its political subdivisions, including any interest or additional penalties accrued thereon.

"Debtor" means any individual, corporation, partnership, association, limited liability company or any other form or business association owing a debt to the state or any of its political subdivisions. "Political subdivision" means any county commission; municipality; county board of education; any instrumentality established by a county or municipality; any separate corporation or instrumentality established by one or more counties or municipalities, as permitted by law; or any public body charged by law with the performance of a government function or whose jurisdiction is coextensive with one or more counties or municipalities. "Related party" means a party, whether an individual, corporation, partnership, association, limited liability company or any other form or business association or other entity whatsoever, related to any vendor by blood, marriage, ownership or contract through which the party has a relationship of ownership or other interest with the vendor so that the party will actually or by effect receive or control a portion of the benefit, profit or other consideration from performance of a vendor contract with the party receiving an amount that meets or exceeds five percent of the total contract amount.

EXCEPTION:

The prohibition of this section does not apply where a vendor has contested any tax administered pursuant to chapter eleven of this code, workers' compensation premium, permit fee or environmental fee or assessment and the matter has not become final or where the vendor has entered into a payment plan or agreement and the vendor is not in default of any of the provisions of such plan or agreement

LICENSING:

Vendors must be licensed and in good standing in accordance with any and all state and local laws and requirements by any state or local agency of West Virginia, including, but not limited to, the West Virginia Secretary of State's Office, the West Virginia Tax Department, West Virginia Insurance Commission, or any other state agencies or political subdivision. Furthermore, the vendor must provide all necessary releases to obtain information to enable the Director or spending unit to verify that the vendor is licensed and in good standing with the above entities.

CONFIDENTIALITY:

The vendor agrees that he or she will not disclose to anyone, directly or indirectly, any such personally identifiable information or other confidential information gained from the agency, unless the individual who is the subject of the information consents to the disclosure in writing or the disclosure is made pursuant to the agency's policies, procedures and rules. Vendors should visit www.state.wv.us/admin/purchase/privacy for the Notice of Agency Confidentiality Policies.

Under penalty of law for false swearing (West Virginia Code, §61-5-3), it is hereby certified that the vendor acknowledges the information in this said affidavit and are in compliance with the requirements as stated

Vendor's Name: C&T Design and Equipment Co., Inc./Mark D. Holmes

Authorized Signature: *Mark D. Holmes* Date: 3-07-07

CONTRACTOR LICENSE

Authorized by the
West Virginia Contractor Licensing Board

Number: WV032078

Classification:
SPECIALTY

C & T DESIGN AND EQUIPMENT CO INC
2855 TOBEY DR
INDIANAPOLIS, IN 46219

Date Issued

JANUARY 27, 2007

Expiration Date

JANUARY 27, 2008



Authorized Company Signature

MICHAEL E. KENNEDY
SECRETARY/TREASURER



Chair, West Virginia Contractor
Licensing Board



**WEST VIRGINIA
CONTRACTOR
LICENSING
BOARD**

This license, or a copy thereof, must be posted in a conspicuous place at every construction site where work is being performed. This license number must appear in all advertisements, on all bid submissions and on all fully executed and binding contracts. This license cannot be assigned or transferred by licensee. Issued under provisions of West Virginia Code, Chapter 21, Article 11.



State of West Virginia
 Department of Administration
 Purchasing Division
 2019 Washington Street East
 Post Office Box 50130
 Charleston, WV 25305-0130

Request for Quotation

RFQ NUMBER
COR61335

PAGE
1

ADDRESS CORRESPONDENCE TO ATTENTION OF
JOHN ABBOTT
304-558-2544

RFQ COPY

TYPE NAME/ADDRESS HERE

*116142806 304-340-0220
 C&T Design and Equip. Co., Inc.
 1415 Stonehenge Road
 Charleston, WV 25314
 WV 032078

DIVISION OF CORRECTIONS
 617 LEON SULLIVAN WAY
 CHARLESTON, WV
 25301 304-558-8045

DATE PRINTED	TERMS OF SALE	SHIP VIA	F.O.B.	FREIGHT TERMS
02/14/2007			destination	included
BID OPENING DATE: 03/07/2007		BID OPENING TIME 01:30PM		

LINE	QUANTITY	UOP	CAT NO	ITEM NUMBER	UNIT PRICE	AMOUNT
				ADDENDUM #01		
				THIS ADDENDUM IS ISSUED TO CANCEL THE PRE-BID MEETING TO BE HELD ON 2/23/2007. THE REASON FOR THE CANCELLATION IS THAT THE KITCHEN AREA IS CURRENTLY UNDER RENOVATION AND NOT AVAILABLE FOR INSPECTION.		
				SUCCESSFUL BIDDER WILL DELIVER, UN-CRATE, ASSEMBLE, SET IN PLACE AND ANCHOR TO THE FLOOR - ALL CONNECTIONS WILL BE COMPLETED AT A LATER TIME BY CORRECTION'S STAFF		
				DUE TO CURRENT RENOVATIONS AND EXACT UNKNOWN DATE OF COMPLETION, VENDOR WILL DELIVER UPON NOTIFICATION OF GROVER ROSENCRANCE, ASSOCIATE WARDEN. PLEASE LIST POINT OF CONTACT WITH PHONE NUMBER(S). ANTICIPATED RENOVATION COMPLETION DATE IS 5/15/2007.		
				ALTERNATE BID PROPOSAL-See Attached Cut Sheets for proposed alternate equipment-all other equipment-included AS SPECIFIED.		\$ 74,989.00

SEE REVERSE SIDE FOR TERMS AND CONDITIONS

SIGNATURE <i>Mark Holmes</i>	TELEPHONE 304-340-0220	DATE 3-07-07
TITLE Sales Consultant	FEIN 35-1315249	ADDRESS CHANGES TO BE NOTED ABOVE

WHEN RESPONDING TO RFQ, INSERT NAME AND ADDRESS IN SPACE ABOVE LABELED 'VENDOR'



State of West Virginia
 Department of Administration
 Purchasing Division
 2019 Washington Street East
 Post Office Box 50130
 Charleston, WV 25305-0130

Request for Quotation

RFQ NUMBER
CDR61335

PAGE
1

ADDRESS CORRESPONDENCE TO ATTENTION OF:
JOHN ABBOTT
304-558-2544

VENDOR

RFQ COPY
 TYPE NAME/ADDRESS HERE
 *116142806 304-340-0220
 C&T Design and Equip.Co., Inc
 1415 Stonehenge Road
 Charleston, WV 25314
 WV032078

SHIP TO

DIVISION OF CORRECTIONS
 617 LEON SULLIVAN WAY
 CHARLESTON, WV
 25301 304-558-8045

DATE PRINTED 02/07/2007	TERMS OF SALE	SHIP VIA	F.O.B. destination	FREIGHT TERMS included
-----------------------------------	---------------	----------	-----------------------	---------------------------

BID OPENING DATE: **03/07/2007** BID OPENING TIME **01:30PM**

LINE	QUANTITY	UOP	CAT NO	ITEM NUMBER	UNIT PRICE	AMOUNT
REQUEST FOR QUOTATION						
THE PURCHASING DIVISION IS SOLICITING BIDS FOR THE HUTTONSVILLE CORRECTIONAL CENTER TO PROVIDE THE INSTALLATION OF CAFETERIA / KITCHEN EQUIPMENT.						
MANDATORY ON-SITE PRE-BID: 2/23/2007; 2:00 PM						
ATTACHMENTS: 1. SPECIFICATIONS 2. AFFIDAVIT						
IF AN EQUAL BRAND & MODEL IS BID, SPECIFICATION DOCUMENTATION AND A COLORED BROCHURE SHALL BE SUBMITTED WITH THE BID.						
PLEASE CONTACT GROVER ROSENCRANCE TWO DAYS PRIOR TO THE PRE-BID DATE TO PRE-REGISTER FOR THE PRE-BID; AT 304-335-2291.						
ALTERNATE BID PROPOSAL-See Attached Cut Sheets for proposed alternate equipment-all other equipment included AS SPECIFIED.						
0001	1	LS		931-30		\$74,989.00
CAFETERIA / KITCHEN EQUIPMENT						
EXHIBIT 5						
NOTICE TO PROCEED: THIS CONTRACT IS TO BE PERFORMED WITHIN 60 CALENDAR DAYS AFTER THE NOTICE TO PROCEED IS RECEIVED. UNLESS OTHERWISE SPECIFIED, THE FULLY EXECUTED PURCHASE ORDER WILL BE CONSIDERED NOTICE TO						

SEE REVERSE SIDE FOR TERMS AND CONDITIONS

SIGNATURE <i>Mark D Holmes</i>	TELEPHONE 304-340-0220	DATE 3-07-07
TITLE Sales Consultant	FEIN 35-1315249	ADDRESS CHANGES TO BE NOTED ABOVE

WHEN RESPONDING TO RFQ, INSERT NAME AND ADDRESS IN SPACE ABOVE LABELED 'VENDOR'



State of West Virginia
 Department of Administration
 Purchasing Division
 2019 Washington Street East
 Post Office Box 50130
 Charleston, WV 25305-0130

Request for Quotation

RFQ NUMBER
COR61335

PAGE
2

ADDRESS CORRESPONDENCE TO ATTENTION OF:
JOHN ABBOTT
304-558-2544

VENDOR

RFQ COPY
 TYPE NAME/ADDRESS HERE

SHIP TO

DIVISION OF CORRECTIONS
617 LEON SULLIVAN WAY
CHARLESTON, WV
25301 304-558-8045

DATE PRINTED 02/07/2007	TERMS OF SALE	SHIP VIA	F.O.B.	FREIGHT TERMS
BID OPENING DATE: 03/07/2007		BID OPENING TIME 01:30PM		

LINE	QUANTITY	UOP	CAT NO	ITEM NUMBER	UNIT PRICE	AMOUNT
<p>PROCEED.</p> <p>CANCELLATION: THE DIRECTOR OF PURCHASING RESERVES THE RIGHT TO CANCEL THIS CONTRACT IMMEDIATELY UPON WRITTEN NOTICE TO THE VENDOR IF THE MATERIALS OR WORKMANSHIP SUPPLIED ARE OF AN INFERIOR QUALITY OR DO NOT CONFORM WITH THE SPECIFICATIONS OF THE BID AND CONTRACT HERE IN.</p> <p>WAGE RATES: THE CONTRACTOR OR SUBCONTRACTOR SHALL PAY THE HIGHER OF THE U.S. DEPARTMENT OF LABOR MINIMUM WAGE RATES AS ESTABLISHED FOR RANDOLPH COUNTY, PURSUANT TO WEST VIRGINIA CODE 21-5A, ET, SEQ. (PREVAILING WAGE RATES APPLY TO THIS PROJECT)</p> <p>ARBITRATION: ANY REFERENCES MADE TO ARBITRATION OR INTEREST FOR PAYMENTS DUE (EXCEPT FOR ANY INTEREST REQUIRED BY STATE LAW) CONTAINED IN THIS CONTRACT OR IN ANY AMERICAN INSTITUTE OF ARCHITECTS DOCUMENTS PERTAINING TO THIS CONTRACT ARE HEREBY DELETED.</p> <p>WORKERS' COMPENSATION: VENDOR IS REQUIRED TO PROVIDE A CERTIFICATE FROM WORKERS' COMPENSATION IF SUCCESSFUL.</p> <p>ALL OF THE ITEMS CHECKED BELOW WILL BE A REQUIREMENT OF THIS CONTRACT:</p> <p>(XX) INSURANCE: SUCCESSFUL VENDOR SHALL FURNISH PROOF OF COMMERCIAL GENERAL LIABILITY INSURANCE PRIOR TO ISSUANCE OF CONTRACT. UNLESS OTHERWISE SPECIFIED IN THE BID DOCUMENTS, THE MINIMUM AMOUNT OF INSURANCE COVERAGE REQUIRED IS \$250,000.</p> <p>() BUILDERS RISK INSURANCE: SUCCESSFUL VENDOR SHALL FURNISH PROOF OF BUILDERS RISK - ALL RISK INSURANCE IN AN AMOUNT EQUAL TO 100% OF THE AMOUNT OF THE CONTRACT.</p>						

SEE REVERSE SIDE FOR TERMS AND CONDITIONS

SIGNATURE	TELEPHONE	DATE
-----------	-----------	------

TITLE	FEIN	ADDRESS CHANGES TO BE NOTED ABOVE
-------	------	-----------------------------------

WHEN RESPONDING TO RFQ, INSERT NAME AND ADDRESS IN SPACE ABOVE LABELED 'VENDOR'



State of West Virginia
 Department of Administration
 Purchasing Division
 2019 Washington Street East
 Post Office Box 50130
 Charleston, WV 25305-0130

Request for Quotation

RFQ NUMBER
COR61335

PAGE
3

ADDRESS CORRESPONDENCE TO ATTENTION OF
JOHN ABBOTT
304-558-2544

VENDOR

RFQ COPY
 TYPE NAME/ADDRESS HERE

SHIP TO

DIVISION OF CORRECTIONS
 617 LEON SULLIVAN WAY
 CHARLESTON, WV
 25301 304-558-8045

DATE PRINTED	TERMS OF SALE	SHIP VIA	F.O.B.	FREIGHT TERMS
02/07/2007				

BID OPENING DATE: **03/07/2007** BID OPENING TIME **01:30PM**

LINE	QUANTITY	UOP	CAT NO.	ITEM NUMBER	UNIT PRICE	AMOUNT
<p>(XX) BONDS: FIVE PERCENT (5%) OF THE TOTAL AMOUNT OF THE BID PAYABLE TO THE STATE OF WEST VIRGINIA, SHALL BE SUBMITTED WITH EACH BID AS A BID BOND. THE SUCCESSFUL BIDDER SHALL ALSO FURNISH A PERFORMANCE BOND AND LABOR/MATERIAL BOND FOR 100% OF THE AMOUNT OF THE CONTRACT. BONDS MAY BE PROVIDED IN THE FORM OF A CERTIFIED CHECK, IRREVOCABLE LETTER OF CREDIT, OR BOND FURNISHED BY A SOLVENT SURETY COMPANY AUTHORIZED TO DO BUSINESS IN THE STATE OF WEST VIRGINIA. A LETTER OF CREDIT SUBMITTED IN LIEU OF A PERFORMANCE AND LABOR & MATERIAL BOND WILL ONLY BE ALLOWED FOR PROJECTS UNDER \$100,000. PERSONAL OR BUSINESS CHECKS ARE NOT ACCEPTABLE IN LIEU OF THE 5% BID BOND, PERFORMANCE BOND, OR LABOR AND MATERIAL BOND.</p> <p>() MAINTENANCE BOND: A TWO (2) YEAR MAINTENANCE BOND COVERING THE ROOFING SYSTEM WILL BE A REQUIREMENT OF THE SUCCESSFUL VENDOR.</p> <p>REV. 11/00</p> <p>EXHIBIT 7</p> <p>DOMESTIC ALUMINUM, GLASS & STEEL IN PUBLIC WORKS PROJECTS</p> <p>IN ACCORDANCE WITH WEST VIRGINIA CODE 5-19-1 ET., SEQ., EVERY CONTRACT FOR CONSTRUCTION, RECONSTRUCTION, ALTERATION, REPAIR, IMPROVEMENT OR MAINTENANCE OF PUBLIC WORKS, WHERE THE COST IS MORE THAN \$50,000 AND, IN THE CASE OF STEEL ONLY, WHERE THE COST OF STEEL IS MORE THAN \$50,000 OR WHERE MORE THAN 10,000 POUNDS OF STEEL ARE REQUIRED, THE STATE WILL ACCEPT ONLY ALUMINUM GLASS, OR STEEL PRODUCTS PRODUCED IN THE UNITED STATES</p>						

SEE REVERSE SIDE FOR TERMS AND CONDITIONS

SIGNATURE	TELEPHONE	DATE
TITLE	FEIN	ADDRESS CHANGES TO BE NOTED ABOVE

WHEN RESPONDING TO RFQ, INSERT NAME AND ADDRESS IN SPACE ABOVE LABELED 'VENDOR'



State of West Virginia
 Department of Administration
 Purchasing Division
 2019 Washington Street East
 Post Office Box 50130
 Charleston, WV 25305-0130

Request for Quotation

RFQ NUMBER
COR61335

PAGE
4

ADDRESS CORRESPONDENCE TO ATTENTION OF
JOHN ABBOTT
304-558-2544

VENDOR

RFQ COPY
 TYPE NAME/ADDRESS HERE

SHIP TO

DIVISION OF CORRECTIONS
 617 LEON SULLIVAN WAY
 CHARLESTON, WV
 25301 304-558-8045

DATE PRINTED 02/07/2007	TERMS OF SALE	SHIP VIA	F.O.B.	FREIGHT TERMS
BID OPENING DATE: 03/07/2007		BID OPENING TIME 01:30PM		

LINE	QUANTITY	UOP	CAT NO	ITEM NUMBER	UNIT PRICE	AMOUNT
<p>IN ADDITION, ITEMS OF MACHINERY OR EQUIPMENT PURCHASED FOR USE AT THE SITE OF PUBLIC WORKS SHALL BE MADE OF DOMESTIC ALUMINUM, GLASS OR STEEL, UNLESS THE COST OF THE PRODUCT IS LESS THAN \$50,000 OR LESS THAN 10,000 POUNDS OF STEEL ARE USED IN PUBLIC WORKS PROJECTS.</p> <p>FOREIGN MADE ALUMINUM, GLASS OR STEEL PRODUCTS MAY BE ACCEPTED ONLY IF THE COST OF DOMESTIC PRODUCTS IS FOUND TO BE UNREASONABLE. SUCH COST IS UNREASONABLE IF IT IS 20% OR MORE HIGHER THAN THE BID PRICE FOR FOREIGN MADE PRODUCTS. IF THE DOMESTIC ALUMINUM, GLASS OR STEEL PRODUCTS TO BE SUPPLIED OR PRODUCED IN A "SUBSTANTIAL LABOR SURPLUS AREA", AS DEFINED BY THE UNITED STATES DEPARTMENT OF LABOR, FOREIGN PRODUCTS MAY BE SUPPLIED ONLY IF DOMESTIC PRODUCTS ARE 30% OR MORE HIGHER IN PRICE THAN THE FOREIGN MADE PRODUCTS.</p> <p>IF, PRIOR TO THE AWARD OF A CONTRACT UNDER THE ABOVE PROVISIONS, THE SPENDING OFFICER OF THE SPENDING UNIT DETERMINES THAT THERE EXISTS A BID FOR LIKE FOREIGN ALUMINUM, GLASS OR STEEL THAT IS REASONABLE AND LOWER THAN THE LOWEST BID DOMESTIC PRODUCTS, THE SPENDING OFFICE MAY REQUEST, IN WRITING, A REEVALUATION AND REDUCTION IN THE LOWEST BID FOR SUCH DOMESTIC PRODUCTS ALL VENDORS MUST INDICATE IN THEIR BID IF THEY ARE SUPPLYING FOREIGN ALUMINUM, GLASS OR STEEL.</p> <p>REV. 3/88</p> <p>EXHIBIT 9</p> <p>NOTICE FOR ISSUANCE & ACKNOWLEDGEMENT OF CONSTRUCTION PROJECT ADDENDA</p> <p>THE ARCHITECT/ENGINEER AND/OR AGENCY SHALL BE REQUIRED</p>						

SEE REVERSE SIDE FOR TERMS AND CONDITIONS

SIGNATURE	TELEPHONE	DATE
TITLE	FEIN	ADDRESS CHANGES TO BE NOTED ABOVE

WHEN RESPONDING TO RFQ, INSERT NAME AND ADDRESS IN SPACE ABOVE LABELED 'VENDOR'



State of West Virginia
 Department of Administration
 Purchasing Division
 2019 Washington Street East
 Post Office Box 50130
 Charleston, WV 25305-0130

Request for Quotation

RFQ NUMBER
COR61335

PAGE
5

ADDRESS CORRESPONDENCE TO ATTENTION OF:
JOHN ABBOTT
304-558-2544

VENDOR

RFQ COPY
 TYPE NAME/ADDRESS HERE

SHIP TO

DIVISION OF CORRECTIONS
617 LEON SULLIVAN WAY
CHARLESTON, WV
25301 **304-558-8045**

DATE PRINTED 02/07/2007	TERMS OF SALE	SHIP VIA	F.O.B.	FREIGHT TERMS
BID OPENING DATE: 03/07/2007		BID OPENING TIME 01:30PM		

LINE	QUANTITY	UQP	CAT NO	ITEM NUMBER	UNIT PRICE	AMOUNT
<p>TO ABIDE BY THE FOLLOWING SCHEDULE IN ISSUING CONSTRUCTION PROJECT ADDENDA FOR STATE AGENCIES:</p> <p>(1) THE ARCHITECT/ENGINEER SHALL PREPARE THE ADDENDUM AND A LIST OF ALL PARTIES THAT HAVE PROCURED DRAWINGS AND SPECIFICATIONS FOR THE PROJECT. THE ADDENDUM AND LIST SHALL BE FORWARDED TO THE BUYER IN THE STATE PURCHASING DIVISION. THE ARCHITECT/ENGINEER SHALL ALSO SEND A COPY OF THE ADDENDUM TO THE STATE AGENCY FOR WHICH THE CONTRACT IS ISSUED.</p> <p>(2) THE BUYER SHALL SEND THE ADDENDUM TO ALL INTERESTED PARTIES AND, IF NECESSARY, EXTEND THE BID OPENING DATE. ANY ADDENDUM SHOULD BE RECEIVED BY THE BUYER WITHIN FOURTEEN (14) DAYS PRIOR TO THE BID OPENING DATE.</p> <p>(3) ALL ADDENDA SHOULD BE FORMALLY ACKNOWLEDGED BY ALL BIDDERS AND SUBMITTED TO THE STATE PURCHASING DIVISION. THE SAME RULES AND REGULATIONS THAT APPLY TO THE ORIGINAL BIDDING DOCUMENT SHALL ALSO APPLY TO AN ADDENDUM DOCUMENT. THE ONLY EXCEPTION MAY BE FOR AN ADDENDUM THAT IS ISSUED FOR THE SOLE PURPOSE OF CHANGING A BID OPENING TIME AND/OR DATE.</p> <p>REV. 11/96</p> <p>EXHIBIT 10</p> <p>ADDENDUM ACKNOWLEDGEMENT</p> <p>I HEREBY ACKNOWLEDGE RECEIPT OF THE FOLLOWING CHECKED ADDENDUM(S) AND HAVE MADE THE NECESSARY REVISIONS TO MY PROPOSAL, PLANS AND/OR SPECIFICATION, ETC.</p>						

SEE REVERSE SIDE FOR TERMS AND CONDITIONS

SIGNATURE	TELEPHONE	DATE
TITLE	FEIN	ADDRESS CHANGES TO BE NOTED ABOVE

WHEN RESPONDING TO RFQ, INSERT NAME AND ADDRESS IN SPACE ABOVE LABELED 'VENDOR'



State of West Virginia
 Department of Administration
 Purchasing Division
 2019 Washington Street East
 Post Office Box 50130
 Charleston, WV 25305-0130

Request for Quotation

RFQ NUMBER
COR61335

PAGE
6

ADDRESS CORRESPONDENCE TO ATTENTION OF:
JOHN ABBOTT
304-558-2544

VENDOR

RFQ COPY
 TYPE NAME/ADDRESS HERE
 *116142806 304-340-0220
 C&T Design and Equip. Co., Inc.
 1415 Stonehenge Road
 Charleston, WV 25314
 WV 032078

SHIP TO

DIVISION OF CORRECTIONS
 617 LEON SULLIVAN WAY
 CHARLESTON, WV
 25301 304-558-8045

DATE PRINTED	TERMS OF SALE	SHIP VIA	F.O.B.	FREIGHT TERMS
02/07/2007			destination	included

BID OPENING DATE: **03/07/2007** BID OPENING TIME **01:30PM**

LINE	QUANTITY	UOP	CAT NO	ITEM NUMBER	UNIT PRICE	AMOUNT
ADDENDUM NOS.:						
NO. 1		2-14-07				
NO. 3						
NO. 4						
NO. 5						
<p>I UNDERSTAND THAT FAILURE TO CONFIRM THE RECEIPT OF THE ADDENDUM(S) MAY BE CAUSE FOR REJECTION OF THE BIDS.</p> <p>..... <i>Mark D Holmes</i> SIGNATURE</p> <p>..... C&T Design and Equip.. Co... Inc. COMPANY</p> <p>..... 3-07-07 DATE</p> <p>REV. 11/96</p> <p>CONTRACTORS LICENSE</p> <p>WEST VIRGINIA STATE CODE 21-11-2 REQUIRES THAT ALL PERSONS DESIRING TO PERFORM CONTRACTING WORK IN THIS STATE MUST BE LICENSED. THE WEST VIRGINIA CONTRACTORS LICENSING BOARD IS EMPOWERED TO ISSUE THE CONTRACTORS LICENSE. APPLICATIONS FOR A CONTRACTORS LICENSE MAY BE MADE BY CONTACTING THE WEST VIRGINIA DIVISION OF LABOR CAPITOL COMPLEX, BUILDING 3, ROOM 319, CHARLESTON, WV 25305. TELEPHONE: (304) 558-7890.</p>						

SEE REVERSE SIDE FOR TERMS AND CONDITIONS

SIGNATURE	TELEPHONE	DATE
<i>Mark D Holmes</i>	304-340-0220	3-07-07
TITLE	FEIN	ADDRESS CHANGES TO BE NOTED ABOVE
Sales Consultant	35-1315249	

WHEN RESPONDING TO RFQ, INSERT NAME AND ADDRESS IN SPACE ABOVE LABELED 'VENDOR'



State of West Virginia
 Department of Administration
 Purchasing Division
 2019 Washington Street East
 Post Office Box 50130
 Charleston, WV 25305-0130

Request for Quotation

RFQ NUMBER
COR61335

PAGE
7

ADDRESS CORRESPONDENCE TO ATTENTION OF:
JOHN ABBOTT
304-558-2544

VENDOR

RFQ COPY
 TYPE NAME/ADDRESS HERE
 *116142806 304-340-0220
 C&T Design and Equip. Co., Inc.
 1415 Stonehenge Road
 Charleston, WV 25314
 WV032078

SHIP TO

DIVISION OF CORRECTIONS
 617 LEON SULLIVAN WAY
 CHARLESTON, WV
 25301 304-558-8045

DATE PRINTED	TERMS OF SALE	SHIP VIA	F.O.B.	FREIGHT TERMS
02/07/2007			destination	included

BID OPENING DATE: **03/07/2007** BID OPENING TIME **01:30PM**

LINE	QUANTITY	UOP	CAT NO	ITEM NUMBER	UNIT PRICE	AMOUNT	
<p>WEST VIRGINIA STATE CODE 21-11-11 REQUIRES ANY PROSPECTIVE BIDDER TO INCLUDE THE CONTRACTORS LICENSE NUMBER ON THEIR BID.</p> <p>BIDDER TO COMPLETE:</p> <p>CONTRACTORS NAME: ...C&T Design and Equip. Co., Inc....</p> <p>CONTRACTORS LICENSE NO.: WV032078.....</p> <p>THE SUCCESSFUL BIDDER WILL BE REQUIRED TO FURNISH A COPY OF THEIR CONTRACTORS LICENSE PRIOR TO ISSUANCE OF A PURCHASE ORDER/CONTRACT</p> <p style="text-align: center;">APPLICABLE LAW</p> <p>THE WEST VIRGINIA STATE CODE, PURCHASING DIVISION RULES AND REGULATIONS, AND THE INFORMATION PROVIDED IN THE "REQUEST FOR QUOTATION" ISSUED BY THE PURCHASING DIVISION IS THE SOLE AUTHORITY GOVERNING THIS PROCUREMENT.</p> <p>ANY INFORMATION PROVIDED IN SPECIFICATION MANUALS, OR ANY OTHER SOURCE, VERBAL OR WRITTEN, WHICH CONTRADICTS OR ALTERS THE INFORMATION PROVIDED FROM THE SOURCES AS DESCRIBED IN THE ABOVE PARAGRAPH IS VOID AND OF NO EFFECT.</p> <p>BANKRUPTCY: IN THE EVENT THE VENDOR/CONTRACTOR FILES FOR BANKRUPTCY PROTECTION, THIS CONTRACT IS AUTOMATICALLY NULL AND VOID, AND IS TERMINATED WITHOUT FURTHER ORDER.</p> <p>REV. 1/2005</p>							\$0000

SEE REVERSE SIDE FOR TERMS AND CONDITIONS

SIGNATURE	TELEPHONE	DATE
<i>Mark D Holmes</i>	304-340-0220	3-07-07
TITLE	FEIN	ADDRESS CHANGES TO BE NOTED ABOVE
Sales Consultant	35-1315249	

WHEN RESPONDING TO RFQ, INSERT NAME AND ADDRESS IN SPACE ABOVE LABELED 'VENDOR'



State of West Virginia
 Department of Administration
 Purchasing Division
 2019 Washington Street East
 Post Office Box 50130
 Charleston, WV 25305-0130

Request for Quotation

RFQ NUMBER
COR61335

PAGE
8

ADDRESS CORRESPONDENCE TO ATTENTION OF:
JOHN ABBOTT 304-558-2544

VENDOR

RFQ COPY
 TYPE NAME/ADDRESS HERE
 *116142806 304-340-0220
 C&T Design and Equip. Co, Inc.
 1415 Stonehenge Road
 Charleston, WV 25314
 WV032078

SHIP TO

DIVISION OF CORRECTIONS
 617 LEON SULLIVAN WAY
 CHARLESTON, WV
 25301 304-558-8045

DATE PRINTED	TERMS OF SALE	SHIP VIA	F.O.B.	FREIGHT TERMS
02/07/2007			destination	included

BID OPENING DATE: 03/07/2007 BID OPENING TIME 01:30PM

LINE	QUANTITY	UOP	CAT NO	ITEM NUMBER	UNIT PRICE	AMOUNT
NOTICE						
A SIGNED BID MUST BE SUBMITTED TO:						
DEPARTMENT OF ADMINISTRATION PURCHASING DIVISION BUILDING 15 2019 WASHINGTON STREET, EAST CHARLESTON, WV 25305-0130						
THE BID SHOULD CONTAIN THIS INFORMATION ON THE FACE OF THE ENVELOPE OR THE BID MAY NOT BE CONSIDERED:						
SEALED BID						
BUYER: JOHN ABBOTT-----						
REQ. NO.: COR61335-----						
BID OPENING DATE: 3/7/2007-----						
BID OPENING TIME: 1:30 PM-----						
PLEASE PROVIDE A FAX NUMBER IN CASE IT IS NECESSARY TO CONTACT YOU REGARDING YOUR BID:						
304-340-0221-----						
PLEASE PRINT OR TYPE NAME OF PERSON TO CONTACT CONCERNING THIS QUOTE:						
MARK D. HOLMES-----						

SEE REVERSE SIDE FOR TERMS AND CONDITIONS

SIGNATURE	TELEPHONE	DATE
<i>Mark D Holmes</i>	304-340-0220	3-07-07
TITLE	FAX	ADDRESS CHANGES TO BE NOTED ABOVE
Sales Consultant	35-1315249	

WHEN RESPONDING TO RFQ, INSERT NAME AND ADDRESS IN SPACE ABOVE LABELED 'VENDOR'



State of West Virginia
 Department of Administration
 Purchasing Division
 2019 Washington Street East
 Post Office Box 50130
 Charleston, WV 25305-0130

Request for Quotation

RFQ NUMBER
COR61335

PAGE
9

ADDRESS CORRESPONDENCE TO ATTENTION OF:
JOHN ABBOTT 304-558-2544

VENDOR

RFQ COPY
 TYPE NAME/ADDRESS HERE
 *116142806 304-340-0220
 C&T Design and Equip. Co., Inc.
 1415 Stonehenge Road
 Charleston, WV 25314
 WV032078

SHIP TO

DIVISION OF CORRECTIONS
 617 LEON SULLIVAN WAY
 CHARLESTON, WV
 25301 304-558-8045

DATE PRINTED	TERMS OF SALE	SHIP VIA	F.O.B.	FREIGHT TERMS
02/07/2007			destination	included

BID OPENING DATE: 03/07/2007 BID OPENING TIME 01:30PM

LINE	QUANTITY	UOP	CAT NO	ITEM NUMBER	UNIT PRICE	AMOUNT
***** THIS IS THE END OF RFQ COR61335 ***** TOTAL:						\$74,989.00

SEE REVERSE SIDE FOR TERMS AND CONDITIONS

SIGNATURE	TELEPHONE	DATE
<i>Mark D Holmes</i>	304-340-0220	3-07-07
TITLE	FEIN	ADDRESS CHANGES TO BE NOTED ABOVE
Sales Consultant	35-1315249	

WHEN RESPONDING TO RFQ, INSERT NAME AND ADDRESS IN SPACE ABOVE LABELED 'VENDOR'

STATE OF WEST VIRGINIA
PURCHASE CONTINUATION SHEET

Buyer: 32	Page: 10	Requisition or P O No : COR61335
Spending Unit:		

Vendor: _____

Item	Quantity	Description	Cost
1	2 each	<p>HEATED CABINET, MOBILE Food Warming Equipment Model No. PST-20 or equal Heated cabinet, mobile, double comp't, insulated, top mounted circulating heat system w/recessed controls, s/s fixed pan slides 2.5" OC, (20) 12x20x2.5 in./Gastro-Norm pans, s/s const'n, H.D. push bars, full bumper, 5" poly casters.</p>	
	2	Two year limited parts & one-year labor warranty, standard.	
	2	20v/50-60/1ph, std.	
	2	LEVEL 2 - Security: thermostat capillary guard, plexiguard thermometer cvr, thermostat retention strap, paddle latch, s/s HD hinges, tamper proof screws, top "MaxiGuard" or dr "Maxi-Slide", S/s tubular hdls, 18 ga. ext'r/20ga int'r	
2	1 each	<p>PEELER, VEGETABLE, ELECTRIC Hobart Model No. 6460c+BUILDUP or Equal Vegetable Peeler, Correctional, 50-60 lb. Potatoes in 1-3 minute cap., V-belt drive, removable, abrasive silicon carbide disc and lexan liner, welded s/s construction, lockable controls, tamper resistant fasteners, 1 hp.</p>	
	1	1-Year parts, labor & travel time during normal working hours w/in theUSA.	
	1	6460C-ELE00E 200-230/60/1	
	1	6460C-SWIT04 4 minute timer switch 1 ph only	
	1	6460C-SWP0RH Switch on RH side	
	1	6460C-LOCYES W/lockable controls	
	1	6460C-CBTSST Cabinet, base and trap - s/s strainer	
3	1 each	<p>GRIDDLE, COUNTER UNIT, ELECTRIC Hobart Model No. CG59-1 or Equal Griddle, Counter Unit, Elec., 72"w x 24"d x 1/2" thick smooth polished steel griddle plate, thermostats @ 12" zones, s/s heating elements, front grease trough, 3" h back splash, s/s exterior, 208/60/1 or 3 ph, 16.2 kw per connection (2)</p>	
	1	1 - Year parts, labor & travel time during normal working hours.	
	1	STAND/L-CG59 Griddle stands w/legs 72" wide	

**STATE OF WEST VIRGINIA
PURCHASE CONTINUATION SHEET**

Buyer: 32	Page: 11	Requisition or P. O. No.: COR61335
Spending Unit:		

Vendor: _____

4	2 each	<p>CONVECTION OVEN, ELECTRIC Hobart Model No. HEC502-208V or Equal Convection Oven, Elec., double-deck, std. Depth, 500 F solid state temp. cont'l, 60 minute timers, 2-speed fans, s/s front, top & sides, porcelain interior, s/s simultaneous doors w/glass, 8" s/s legs, 208v/60/1 or 3 ph, 12 kw each. PRICE TO INCLUDE CORRECTIONAL PACKAGE FOR EACH DOUBLE STACK-</p>
	2	1-Year parts, labor & travel time during normal working hours
5	1 each	<p>STEAMER, PRESSURE, DIRECT STEAM Southbend Model No. DC-3S or Equal Steamer, Pressure-Type, Direct, 3 compartments, 36" cabinet base, manual timer controls, s/s interior & exterior</p>
	1	115/60/1-ph, std.
	1	35 PSI std,
	1	Standard one year limited warranty
	1	Cabinet base doors w/locking provisions
	1	Correctional screws & tack welds
6	1 each	<p>TILTING KETTLE, DIRECT STEAM Southbend Model NO. KDL-100 or Equal Tilting Kettle, Direct, 100-gal cap., two-thirds jacket, s/s interior & exterior, s/s console w/crank tilt w/self-locking positive stop, s/s tri-leg base, 35 PSI</p>
	1	Standard one year limited warranty
	1	IVT-3 3" tangent draw off valve added to tilting kettle
	1	Correctional screws & tack welds where applicable
	1	s/s cover over control panel w/locking provisions
7	2 each	<p>FRYER, ELECTRIC Hobart Model No. 1HF85C-3 or Equal Fryer, Electric, 85 lbs., computer controls, melt cycle, single autobasket lift, s/s tank with 1 1/4" full port drain valve, s/s front & sides, 208/60/3, 24KW heating element, filter ready, on 4" legs</p>
	2	HBASKET-TWIN85 Twin Baskets HF85
	1	GRSTRIP-SPERH Banking strips
8	1 each	<p>MOBILE FILTER Hobart Model No. 85HMF-5 or Equal Mobile Filter, 100 lbs. Capacity, 208/60/1 NOTE: Please confirm voltage and basket quantity.</p>

RFQ No COR61335

A F F I D A V I T

West Virginia Code §5A-3-10a states:

No contract or renewal of any contract may be awarded by the state or any of its political subdivisions to any vendor or prospective vendor when the vendor or prospective vendor or a related party to the vendor or prospective vendor is a debtor and the debt owned is an amount greater than one thousand dollars in the aggregate

DEFINITIONS:

"Debt" means any assessment, premium, penalty, fine, tax or other amount of money owed to the state or any of its political subdivisions because of a judgment, fine, permit violation, license assessment, defaulted workers' compensation premium, penalty or other assessment presently delinquent or due and required to be paid to the state or any of its political subdivisions, including any interest or additional penalties accrued thereon.

"Debtor" means any individual, corporation, partnership, association, limited liability company or any other form or business association owing a debt to the state or any of its political subdivisions "Political subdivision" means any county commission; municipality; county board of education; any instrumentality established by a county or municipality; any separate corporation or instrumentality established by one or more counties or municipalities, as permitted by law; or any public body charged by law with the performance of a government function or whose jurisdiction is coextensive with one or more counties or municipalities. "Related party" means a party, whether an individual, corporation, partnership, association, limited liability company or any other form or business association or other entity whatsoever, related to any vendor by blood, marriage, ownership or contract through which the party has a relationship of ownership or other interest with the vendor so that the party will actually or by effect receive or control a portion of the benefit, profit or other consideration from performance of a vendor contract with the party receiving an amount that meets or exceeds five percent of the total contract amount.

EXCEPTION:

The prohibition of this section does not apply where a vendor has contested any tax administered pursuant to chapter eleven of this code, workers' compensation premium, permit fee or environmental fee or assessment and the matter has not become final or where the vendor has entered into a payment plan or agreement and the vendor is not in default of any of the provisions of such plan or agreement.

LICENSING:

Vendors must be licensed and in good standing in accordance with any and all state and local laws and requirements by any state or local agency of West Virginia, including, but not limited to, the West Virginia Secretary of State's Office, the West Virginia Tax Department, West Virginia Insurance Commission, or any other state agencies or political subdivision. Furthermore, the vendor must provide all necessary releases to obtain information to enable the Director or spending unit to verify that the vendor is licensed and in good standing with the above entities.

CONFIDENTIALITY:

The vendor agrees that he or she will not disclose to anyone, directly or indirectly, any such personally identifiable information or other confidential information gained from the agency, unless the individual who is the subject of the information consents to the disclosure in writing or the disclosure is made pursuant to the agency's policies, procedures and rules. Vendors should visit www.state.wv.us/admin/purchase/privacy for the Notice of Agency Confidentiality Policies.

Under penalty of law for false swearing (West Virginia Code, §61-5-3), it is hereby certified that the vendor acknowledges the information in this said affidavit and are in compliance with the requirements as stated.

Vendor's Name: C&T Design and Equipment Co., Inc./Mark D. Holmes

Authorized Signature: Mark D Holmes Date: 3-07-07

WV 032078

CONTRACTOR LICENSE

Authorized by the

West Virginia Contractor Licensing Board

Number: WV032078

Classification:

SPECIALTY

C & T DESIGN AND EQUIPMENT CO INC
2855 TOBEY DR
INDIANAPOLIS, IN 46219

Date Issued

JANUARY 27, 2007

Expiration Date

JANUARY 27, 2008

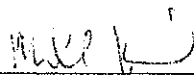

Authorized Company Signature

MICHAEL E. KENNEDY
SECRETARY/TREASURER



Chair, West Virginia Contractor
Licensing Board



**WEST VIRGINIA
CONTRACTOR
LICENSING
BOARD**

This license, or a copy thereof, must be posted in a conspicuous place at every construction site where work is being performed. This license number must appear in all advertisements, on all bid submissions and on all fully executed and binding contracts. This license cannot be assigned or transferred by licensee. Issued under provisions of West Virginia Code, Chapter 21, Article 11.



Item #: **4**
 Model: **MCO-ES-10/20-S** MCO-ED-10/20-S
 Product Name: Master Electric Convection Oven

MCO-ES-20-S



QUANTITY
(2)

Model MCO-ES-10-S

Specification:

Garland Master full-size Standard Depth Single or Double (MCO-ES-10/20-S) or Deep Depth Single or Double (MCO-ED-10/20-S) electric convection oven. 10.4 kW/ cavity, 3/4 HP fan motor with two speed fan control. Master 200 Solid State control Porcelain enameled oven interior with coved corners, Six (6) oven racks and 13-position rack guides. Interior measures 29"(736mm) W x 24" (610mm) H x 24" (610mm) D for standard depth and 29" (736mm) W x 24" (610mm) H x 28" (610mm) D for deep depth. Stainless steel front, sides, top and legs. 60/40 dependent door design with double pane thermal window in both doors and interior lighting. Specify voltage and phase. UL, CUI and NSF Listed. Ovens with optional 400 series controllers are CE approved

Standard Features:

- Master 200 Solid State Control with 150° F (66°C) to 500°F (250°C) temperature range and electromechanical timer
- 2-speed fan control (high & low) w/3/4HP fan motor
- Total of 10 4 kW loading per oven cavity
- Stainless steel front, sides, top, and legs
- 60/40 dependent door design with double pane thermal window in both doors and interior lighting
- Full Length, stainless steel positive door closure
- Patented "Safety Door System"
- Porcelain enameled oven interior with coved corners
- 24" cooking cavity height w/6 chrome plated oven racks on 13-position rack guides
- Double deck models available.
- 1 year limited parts & labor warranty (USA & Canada only)
- 5 year limited door warranty, excluding window (USA & Canada only)

Optional Features:

- Manufactured as U.S. Range Brand – No Charge, specify
- Solid State, Digital Controls W/ Cook'N Hold, Pulse Fan, Auto Setback, and Auto Cool Down; CE Approved
 - Master 450 as above
 - Master 455 (as above plus) Core Probe
 - Master 475 (as above plus) Programmable Product Keys
- Window in left hand door w/interior lighting
- Stainless steel solid doors
- Stainless steel oven interior
- Extra oven racks
- 4 swivel casters w/front brakes
- Low profile casters w/front brakes (double ovens only)
- Open base with rack guides & shelf (stainless steel)
- Back enclosure (stainless steel)
- 460 volt, 3 phase
- 50 cycle components

NOTE: Ovens supplied with casters must be installed with an approved restraining device.

w/ ARISON PKG



Garland Commercial Industries, Inc
 185 East South Street
 Freeland, Pennsylvania 18224
 Phone: (570) 636-1000
 Fax: (570) 636-3903

Garland Commercial Ranges Ltd
 1177 Karnato Road, Mississauga, Ontario
 L4W 1X4 CANADA
 Phone: 905-624-0260
 Fax: 905-624-5669

Enodis UK LTD
 Swallowfield Way, Hayes, Middlesex
 UB3 1DQ ENGLAND
 Telephone: 081-561-0433
 Fax: 081-848-0041

GARLAND® ELECTRIC Master Electric Convection Oven MCO-ES-10/20-S, MCO-ED-10/20-S



GARLAND®

Item #: _____
 Model: MCO-ES-10/20-S, MCO-ED-10/20-S
 Product Name: Master Electric Convection Oven

MCO-ES-10/20-S, MCO-ED-10/20-S

Master Electric Convection Oven

GARLAND® ELECTRIC

Model	Interior Dimension (per oven)			Exterior Dimension			Ship Wt./Size	
	W:In(mm)	H:In(mm)	D:In(mm)	W:In(mm)	H:In(mm) **	D:In(mm)	ILbs./Kg	Cu Ft
MCO-ES-10-S	29(436)	24(610)	24(610)	38(965)	57-1/2(1416)	41-1/4(1048)	460/210	42
MCO-ES-20-S	29(436)	24(610)	24(610)	38(965)	70-1/2(1791)	41-1/4(1048)	920/415	84
MCO-ED-10-S	29(436)	24(610)	28(711)	38(965)	57-1/2(1416)	44-1/2(1130)	530/240	42
MCO-ED-20-S	29(436)	24(610)	28(711)	38(965)	70-1/2(1791)	44-1/2(1130)	1060/480	84

** Height with or without standard casters. Height with low profile casters (double deck) is 68-1/2" (1740mm)

Model*	Total kW	Nominal Amperes Per Line (includes 3/4 HP fan motor)										
		208v/1Ph	240V/1Ph	208V/3Ph			240V/3Ph			460V/3Ph		
				X	Y	Z	X	Y	Z	X	Y	Z
MCO-ES-10-S	10.4	50	43	30	30	28	26	26	24	14	14	13
MCO-ED-10-S	10.4	50	43	30	30	38	26	26	24	14	14	13

*NOTE: Double deck models with suffix - "20-S" are provided with individual power supply connections

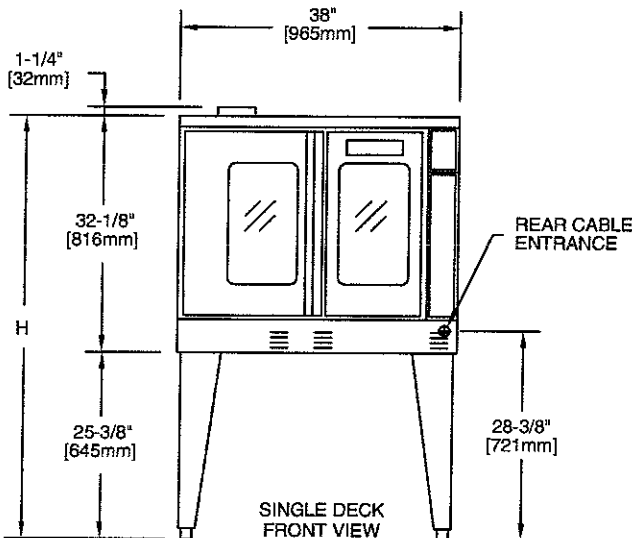
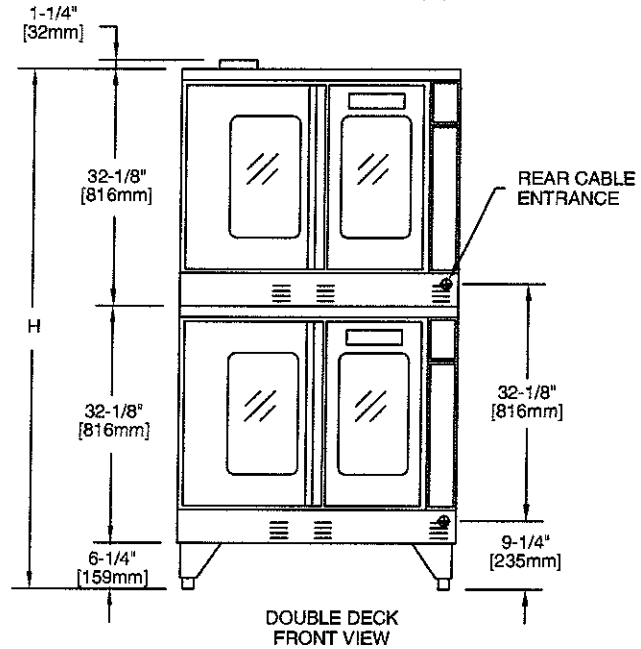
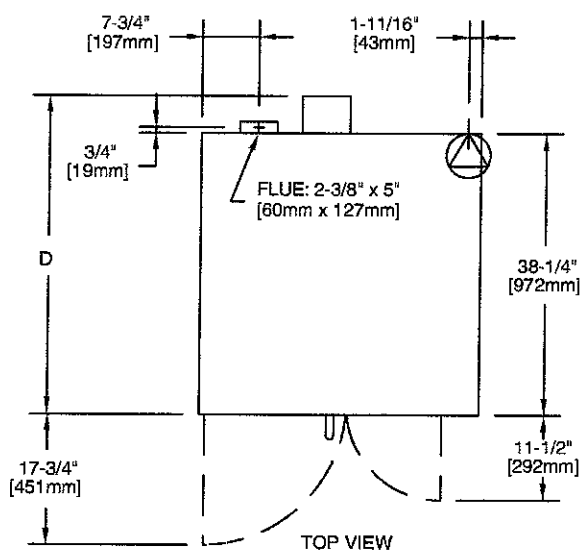

Installation Notes:			
Non-Combustible and Combustible Wall Clearances			
Sides	1" (25mm)	Back	6" (152mm)
Entry Clearance			
Crated		Uncrated	
44-1/2" (1130mm)		32-1/2" (862mm)	

Electrical specifications include motor requirements. 3/4 HP, 2 speed motor: 1725/1140 rpm, (60Hz); or 1440/950 rpm (50Hz). Please specify electrical characteristics when ordering

Continuous product improvement is a Garland policy. Specifications and design are subject to change without notice

Printed in USA

Form #MCO-ES/ED-10/20-S (12/06)

ITEM #S



CROWN FOOD SERVICE EQUIPMENT LTD
70 OAKDALE ROAD, TORONTO, CANADA M3N 1V9
TELEPHONE (416) 746-2358 FAX: (416) 746-8324



DIRECT STEAM CABINET BASE COMPARTMENT COOKER

D

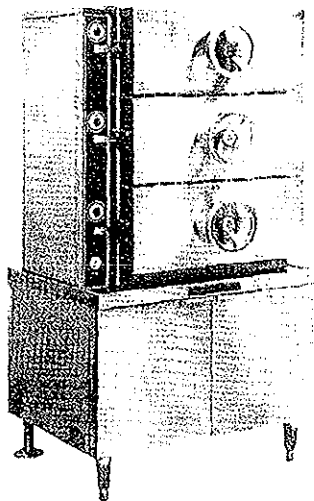

Model	Compartments	Capacity
DC-2	2	8-16 Pans
→ DC-3	3	12-24 Pans

OPERATION SHALL BE BY:

Direct non-toxic steam incoming at a minimum of 15 psi (103 kPa) with a flow of 150 psi (68kg) per hour. A pressure reducing valve shall provide compartment pressure of 6 psi (41 kPa) and a control system is provided to cool the condensate drain.

The control shall be equipped for operate on 115 VAC 1 Phase 60 Hz

OPTIONAL ITEMS AT EXTRA COST:

- Stainless steel rear panel
- Front flange feet
- 220 VAC 1 Phase, 60 Hz
- 240 VAC, 1 Phase 60 Hz

ACCESSORIES:

- Extra shelf
- 12" x 20" x 2-1/2" perforated stainless steel pan
- 12" x 20" x 2-1/2" solid stainless steel pan
- 12" x 20" x 4" perforated stainless steel pan
- 12" x 20" x 4" solid stainless steel pan
- Ball float trap
- Spray and rinse assembly

w/ PRISON AKG

SPECIFICATIONS:

Shall be a CROWN Model _____ pressure compartment cooker operating on direct steam. The cooker shall be constructed of all-welded satin finish stainless steel, type 304. The doors shall have a removable inner liner of aluminum plate with full perimeter gasket seal, and a wheel-and-screw closing mechanism. The doors, with a clear opening of 10-1/4" x 26-3/8" (260 x 670mm), shall latch upon closing, and shall open 15° upon latch release. Compartment operation shall be at a maximum pressure of 6 psi (41kPa)

The control housing shall be constructed of stainless steel with a full-access removable panel. The timing of each compartment shall be independently controlled by:

- Automatic timer controls with visible and audible signals. At the end of the cooking cycle, the controls automatically shut off and exhaust the incoming steam, drain the condensate from the compartment and sound a continuous signal until turned off manually.

Each cooking compartment shall have either removable shelf supports with one slide-out shelf (second shelf optional) or removable universal pan supports. The capacities shall range as follows:



- Shelf supports: Four full size (1/1 gastronorm) pans 2-1/2' or 4' (64mm or 100mm) deep

The compartment cooker shall be mounted on a cabinet base with full perimeter angle frame, reinforced counter, all stainless steel #4 finish type 304 exterior, hinged doors and 6" (152mm) stainless steel legs with adjustable bullet feet on the front and flanged on the rear.



CROWN DETAILS AND DIMENSIONS

SERVICE CONNECTIONS

-  - ELECTRICAL CONNECTION: 1/2" conduit connection to controls 2 AMPS per compartment 120-60-1 or 220-50-1
-  - DRAIN: 2 IPS piped to open floor drain No solid connection
-  - STEAM SUPPLY: 3/4" IPS for incoming steam at 40-50 PSI (276-345 kPa)*

*Pressure reducing valve is required if incoming pressure exceeds 50 PSI (345 kPa)

DC-2, DC-3

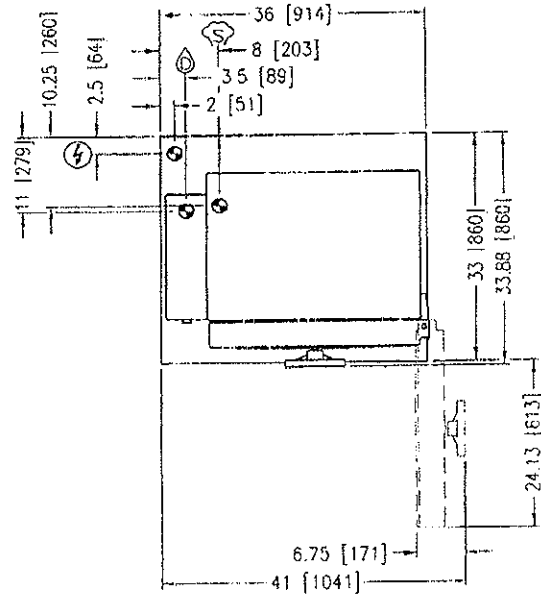
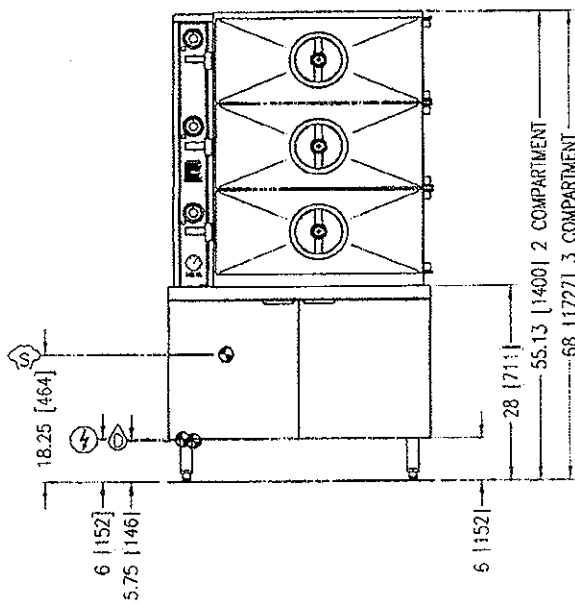
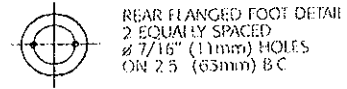

IN (mm)
314GR1

04/01



ATTN: ~~MARK~~ MARK
Project ID:

4 PAGES.

MUTTONSUILLE CORREC.



DIRECT STEAM TRI-LEG
TILTING KETTLE

ITEM # 6
QUANTITY (1)

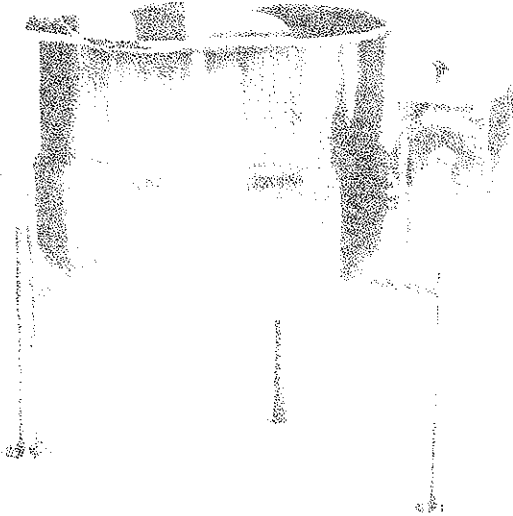

Model	Capacity	
DLT-20	20 Gallon	76 Litre
DLT-30	30 Gallon	114 Litre
DLT-40	40 Gallon	151 Litre
DLT-60	60 Gallon	227 Litre
DLT-80	80 Gallon	303 Litre
→ DLT-100	100 Gallon	379 Litre

OPERATION SHALL BE BY:

Direct steam at a minimum of 5 PSI (34kPa) and a maximum of 30 PSI (207kPa)

OPTIONAL ITEMS AT EXTRA COST:

- Type 316 stainless steel liner for high acid content cooking on models 60 through 100 gallons
- 50 PSI (345kPa) high pressure operation for higher cooking temperature on models 20 to 100 gallons
- 3" (76 mm) draw off valve (TVS-3)
- 2 (50 mm) dairy valve (DDO-2)
- 3 (76 mm) dairy valve (DDO-3)
- Spring assist hinged stainless steel cover (SA-1)
- Two piece hinged cover (TPHC)
- Etched gallon markings (GM-)
- Etched litre markings (LM-)
- Correctional package

ACCESSORIES:

- Triple basket assembly (TBA-)
- Steam trap assembly (consisting of steam trap check valve, Y strainer (STA-2))
- Perforated strainer for draw off valve (TPS-)
- Draw off valve hose kit with 8 hose (DVHK-2)
- Single pantry faucet with swing spout (SF-18)
- Double pantry faucet with swing spout (DF-18)
- Graduated measuring strip (CMS-)
- Solid disc for draw off valve (TSS-)
- Graduated measuring strip (CMS-)
- Solid disc for draw off valve (TSS-)
- Pour lip strainer (TKS-20)
- One piece lift-off stainless steel cover (C-20)
- Strainer hook (SH-20)

SPECIFICATIONS:

Shall be a ConoTech Model **K-DLT-100**, direct steam connected tri-leg tilting kettle. A double wall kettle interior shall form a steam jacket around the lower 2/3 of the kettle. The bottom of the kettle shall be of hemispherical design for superior heat circulation.

The tri-leg mounting frame of stainless steel pipe shall support the kettle and tilt console and conceal the steam piping, house the steam control valve and tilt mechanism. Each leg shall be fitted with a 4 hole adjustable flanged foot for securing to the floor. The tilt mechanism shall permit the kettle to tilt forward a full 90° for complete emptying. The tilting mechanism shall be self locking for positive stop action.

Construction shall be all welded #4 finish stainless steel type 304. The liner on models 20 through 40 gallon shall be standard 316 for high acid content cooking.

HEAVY DUTY STEAM





SERVICE CONNECTIONS

- ☞ - STEAM SUPPLY: 3/4" IPS 5 30 psi (34 205 kPa) Optional 5 45 psi (34 310 kPa) *
- ☞ - CONDENSATE RETURN: 1/2" IPS
- ☞ - COLD WATER: 3/8" O.D tubing to faucet (OPTIONAL)
- ☞ - HOT WATER: 3/8" O.D tubing to faucet (OPTIONAL)

DIMENSIONS

MODEL	CAPACITY	UNITS	A	B	C	D	E	F	G	H(2")	H(3")	J(2")	J(3")	K	L	M
DLT-20	20 gallons	inches	21	18	37	34.75	28.5	22	25.63	12	13.25	17	16.5	59.5		15.38
	76 litres	mm	535	460	940	885	724	559	651	305	337	432	419	1512		391
DLT-30	30 gallons	inches	24	20	37	37.75	31.5	20.75	27.13	12.5	14.25	15	14.5	62.5		15.38
	114 litres	mm	610	510	940	960	800	527	689	317	362	381	368	1588		391
DLT-40	40 gallons	inches	26	22.5	37	39.75	33.5	20.25	28.63	13	15.25	12.5	12	64		16.38
	152 litres	mm	660	570	940	1010	850	514	727	330	387	318	305	1626		416
DLT-60	60 gallons	inches	29.5	26	40.5	43.25	37	21.5	30.13	15.5	15.5	14.5	14	74	9.5	18.38
	227 litres	mm	750	660	1029	1100	940	546	765	394	394	368	356	1879	241	467
DLT-80	80 gallons	inches	33	28	42.5	46.75	40.5	20	32.63	14.5	16.25	12.5	12	76	11	19.88
	303 litres	mm	840	710	1080	1185	1030	508	828	368	413	318	305	1930	279	505
DLT-100	100 gallons	inches	35.5	30	42.5	49.25	43	21	39.25	18	20.25	10.5	10	79	12.5	21.5
	379 litres	mm	902	762	1080	1251	1092	533	997	457	514	267	254	2007	318	546

* Pressure reducing valve is required if incoming pressure exceeds 50 PSI(345 kPa)

SAFETY RELIEF VALVE

STRAINER AND STEAM TRAP (OPTIONAL)

NOTE: 60, 80 & 100 GALLON KETTLES ARE SUPPLIED WITH 2 REAR SUPPORT LEGS

FLANGED FOOT DETAIL
4 EQUALLY SPACED Ø7/16" (11mm) HOLES ON 3" (76mm) B.C

2 VALVE:
CLOSED 5.13" (130mm)
OPENED 6.88" (175mm)

3 VALVE:
CLOSED 7.88" (200mm)
OPENED 10.13" (257mm)

MODEL	SHIPPING WT.	MIN. CLEARANCE	
DLT-20	240 lbs. (109 kg)	SIDES	0
DLT-30	285 lbs. (129 kg)		0
DLT-40	332 lbs. (151 kg)	BACK	0
DLT-60	356 lbs. (166 kg)		0
DLT-80	424 lbs. (192 kg)		
DLT-100	480 lbs. (218 kg)		

SPRING ASSISTED COVER - OPTIONAL

JACKET DRAIN VALVE

OPTIONAL FAUCET

2" or 3" TANGENT DRAW OFF VALVE (OPTIONAL)

IN (mm)

As continued product improvement is a policy of ConoTech specifications are subject to change without notice

BID BOND

KNOW ALL MEN BY THESE PRESENTS that we C & T Design and Equipment Co., Inc.
2855 Tobey Drive, Indianapolis, IN 46219

as Principal hereinafter called the Principal, and Western Surety Company
101 S. Phillips Avenue, Sioux Falls, SD 57104

a corporation duly organized under the laws of the State of South Dakota as Surety hereinafter
called the Surety are held and firmly bound unto State of West Virginia / Department of Administration
Purchasing Division; 2019 E. Washington St. Charleston, WV 25305 as Obligees hereinafter called the Obligees in the sum of
5% of the accompanying bid Dollars (\$)
for the payment of which sum well and truly to be made, the said Principal and the said Surety bind ourselves our heirs executors
administrators, successors and assigns jointly and severally firmly by these presents

WHEREAS, the Principal has submitted a bid for Huttonsville Correctional Center

NOW THEREFORE if the Obligees shall accept the bid of the Principal and the Principal shall enter into a Contract with the Obligees in
accordance with the terms of such bid, and give such bond or bonds as may be specified in the bidding or Contract Documents with
good and sufficient surety for the faithful performance of such Contract and for the prompt payment of labor and material furnished in
the prosecution thereof or in the event of the failure of the Principal to enter such Contract and give such bond or bonds if the
Principal shall pay to the Obligees the difference not to exceed the penalty hereof between the amount specified in said bid and such
larger amount for which the Obligees may in good faith contract with another party to perform the Work covered by said bid then this
obligation shall be null and void otherwise to remain in full force and effect

Signed and sealed this 7th day of March, 2007

Penny D. Zickafoose
(Witness)
PENNY D. ZICKAFOOSE

Sandy Rupert
(Witness)
Sandy Rupert

C & T DESIGN AND EQUIPMENT CO., INC.
(Principal) (Seal)

Michael E. Kennedy
(Title)

MICHAEL E. KENNEDY, SECRETARY/TREASURER

Shawnda A. Marshall
Western Surety (Surety) (Seal)

Shawnda A. Marshall, Attorney-in-fact
(Title)

Printed in cooperation with the American Institute of Architects (AIA) by the CNA Insurance Companies

The language in this document conforms exactly to the language used in AIA Document A310 - Bid Bond - February 1970 Edition

Western Surety Company

POWER OF ATTORNEY APPOINTING INDIVIDUAL ATTORNEY-IN-FACT

Know All Men By These Presents, That WESTERN SURETY COMPANY, a South Dakota corporation. is a duly organized and existing corporation having its principal office in the City of Sioux Falls, and State of South Dakota, and that it does by virtue of the signature and seal herein affixed hereby make, constitute and appoint

Sheila K Frederick, Hugh B Mc Gowan, Carl Boyer, Shawnda A Marshall, Katie L Mullins, Hugh M Mc Gowan, Michael J Highum, Individually

of Indianapolis, IN, its true and lawful Attorney(s)-in-Fact with full power and authority hereby conferred to sign, seal and execute for and on its behalf bonds, undertakings and other obligatory instruments of similar nature

- In Unlimited Amounts -

and to bind it thereby as fully and to the same extent as if such instruments were signed by a duly authorized officer of the corporation and all the acts of said Attorney, pursuant to the authority hereby given. are hereby ratified and confirmed

This Power of Attorney is made and executed pursuant to and by authority of the By-Law printed on the reverse hereof, duly adopted, as indicated, by the shareholders of the corporation

In Witness Whereof, WESTERN SURETY COMPANY has caused these presents to be signed by its Senior Vice President and its corporate seal to be hereto affixed on this 19th day of January, 2007



WESTERN SURETY COMPANY

Paul T. Bruflat
Paul T. Bruflat, Senior Vice President

State of South Dakota }
County of Minnehaha } ss

On this 19th day of January, 2007, before me personally came Paul T Bruflat, to me known who, being by me duly sworn, did depose and say: that he resides in the City of Sioux Falls. State of South Dakota; that he is the Senior Vice President of WESTERN SURETY COMPANY described in and which executed the above instrument; that he knows the seal of said corporation; that the seal affixed to the said instrument is such corporate seal; that it was so affixed pursuant to authority given by the Board of Directors of said corporation and that he signed his name thereto pursuant to like authority, and acknowledges same to be the act and deed of said corporation

My commission expires

November 30, 2012

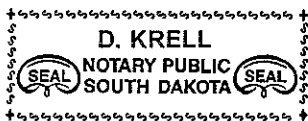

D. Krell
D. Krell, Notary Public

CERTIFICATE

I, L. Nelson, Assistant Secretary of WESTERN SURETY COMPANY do hereby certify that the Power of Attorney hereinabove set forth is still in force and further certify that the By-Law of the corporation printed on the reverse hereof is still in force In testimony whereof I have hereunto subscribed my name and affixed the seal of the said corporation this 7th day of MARCH 2007



WESTERN SURETY COMPANY

L. Nelson
L. Nelson, Assistant Secretary

Authorizing By-Law

ADOPTED BY THE SHAREHOLDERS OF WESTERN SURETY COMPANY

This Power of Attorney is made and executed pursuant to and by authority of the following By-Law duly adopted by the shareholders of the Company

Section 7 All bonds, policies, undertakings, Powers of Attorney, or other obligations of the corporation shall be executed in the corporate name of the Company by the President, Secretary, and Assistant Secretary, Treasurer, or any Vice President, or by such other officers as the Board of Directors may authorize. The President, any Vice President, Secretary, any Assistant Secretary, or the Treasurer may appoint Attorneys in Fact or agents who shall have authority to issue bonds, policies, or undertakings in the name of the Company. The corporate seal is not necessary for the validity of any bonds, policies, undertakings, Powers of Attorney or other obligations of the corporation. The signature of any such officer and the corporate seal may be printed by facsimile.



Letter of Transmittal

1415 Stonehenge Road, Charleston, WV 25314

PH: 304-340-0220

FAX: 304-340-0221

TO: State of WV/Dept. of Administration
Purchasing Division/2019 Wash St E
Charleston, WV 25305-0130

DATE: 3-07-06

SUBJECT: Huttonsville Correctional
Center

ATTN: Bid Committee

We are sending you the following: Bid Proposal/RFQ# COR61335

- | | |
|---|--|
| <input checked="" type="checkbox"/> Enclosed | <input type="checkbox"/> Rough-in drawings |
| <input type="checkbox"/> Under separate cover | <input type="checkbox"/> Shop drawings |
| <input type="checkbox"/> By messenger | <input type="checkbox"/> Equipment brochures |

Copies	Type	Description
1	ORIGINAL	Bid Proposal/RFQ# COR61335/Huttonsville Correctional Center/AS SPECIFIED
1	ORIGINAL	Bid Proposal/RFQ#COR61335/Huttonsville Correctional Center/W/ALTERNATES/See Attached Cut Sheets
1ea	ORIGINAL	Affidavit
1ea	COPY	WV Contractor's License
1	ORIGINAL	Bid Bond

These are transmitted:

- | | |
|---|--|
| <input checked="" type="checkbox"/> As requested | <input type="checkbox"/> For approval |
| <input type="checkbox"/> For review and comment | <input type="checkbox"/> Approved as noted |
| <input type="checkbox"/> For your use | <input type="checkbox"/> Approved |
| <input type="checkbox"/> For correction & resubmittal | <input type="checkbox"/> See remarks |

REMARKS:

cc: File
MARK HOLMES

Mark D Holmes
C & T DESIGN AND EQUIPMENT CO., INC.