



State of West Virginia  
 Department of Administration  
 Purchasing Division  
 2019 Washington Street East  
 Post Office Box 50130  
 Charleston, WV 25305-0130

# Request for Quotation

RFQ NUMBER  
**857C2054**

PAGE  
**1**

ADDRESS CORRESPONDENCE TO ATTENTION OF  
**JOHN JOHNSTON  
 304-558-2402**

RFQ COPY  
 TYPE NAME/ADDRESS HERE

VENDOR

SHIP TO

**TraFix Devices Inc.  
 220 Calle Pintesco  
 San Clemente, CA 92672**

**DIVISION OF HIGHWAYS  
 VARIOUS LOCALES AS INDICATED  
 BY ORDER**

DATE PRINTED	TERMS OF SALE	SHIP VIA	F.O.B.	FREIGHT TERMS
04/11/2007				

BID OPENING DATE: **05/02/2007** BID OPENING TIME: **01:30PM**

LINE	QUANTITY	UOP	CAT NO	ITEM NUMBER	UNIT PRICE	AMOUNT
0001	1	LS		968-80		
<p><b>PORTABLE SIGN STANDS AND ROLL-UP SIGNS</b></p> <p><b>OPEN END CONTRACT</b></p> <p>TO FURNISH COMPACT PORTABLE SIGN STANDS AND HIGHLY REFLECTIVE ROLL-UP SIGNS AS REQUIRED TO THE WEST VIRGINIA DIVISION OF HIGHWAYS (WVDDH).</p> <p>SEE ATTACHED</p> <p>EXHIBIT 3</p> <p>LIFE OF CONTRACT: THIS CONTRACT BECOMES EFFECTIVE ON ..... AND EXTENDS FOR A PERIOD OF ONE (1) YEAR OR UNTIL SUCH "REASONABLE TIME" THEREAFTER AS IS NECESSARY TO OBTAIN A NEW CONTRACT OR RENEW THE ORIGINAL CONTRACT. THE "REASONABLE TIME" PERIOD SHALL NOT EXCEED TWELVE (12) MONTHS. DURING THIS "REASONABLE TIME" THE VENDOR MAY TERMINATE THIS CONTRACT FOR ANY REASON UPON GIVING THE DIRECTOR OF PURCHASING 30 DAYS WRITTEN NOTICE.</p> <p>UNLESS SPECIFIC PROVISIONS ARE STIPULATED ELSEWHERE IN THIS CONTRACT DOCUMENT, THE TERMS, CONDITIONS AND PRICING SET HEREIN ARE FIRM FOR THE LIFE OF THE CONTRACT.</p> <p>RENEWAL: THIS CONTRACT MAY BE RENEWED UPON THE MUTUAL WRITTEN CONSENT OF THE SPENDING UNIT AND VENDOR, SUBMITTED TO THE DIRECTOR OF PURCHASING THIRTY (30) DAYS PRIOR TO THE EXPIRATION DATE. SUCH RENEWAL SHALL BE IN ACCORDANCE WITH THE TERMS AND CONDITIONS OF THE</p>						
<i>SEE PRICE PAGES</i>						

RECEIVED

2007 MAY -2 A 10: 26

PURCHASING DIVISION  
 STATE OF WV

SEE REVERSE SIDE FOR TERMS AND CONDITIONS

SIGNATURE: *[Signature]* TELEPHONE: **909 361 5063** DATE: **4/25/07**

TITLE: **CONTRACT SPECIALIST** 338217824 ADDRESS CHANGES TO BE NOTED ABOVE

WHEN RESPONDING TO RFQ, INSERT NAME AND ADDRESS IN SPACE ABOVE LABELED 'VENDOR'



State of West Virginia  
 Department of Administration  
 Purchasing Division  
 2019 Washington Street East  
 Post Office Box 50130  
 Charleston, WV 25305-0130

# Request for Quotation

RFQ NUMBER  
**857C2054**

PAGE  
**2**

ADDRESS CORRESPONDENCE TO ATTENTION OF:  
**JOHN JOHNSTON**  
**304-558-2402**

VENDOR

RFQ COPY  
 TYPE NAME/ADDRESS HERE

**Traffix Devices Inc.**  
**220 Calle Pintoresco**  
**San Clemente, CA 92672**

SHIP TO

**DIVISION OF HIGHWAYS**  
**VARIOUS LOCALES AS INDICATED**  
**BY ORDER**

DATE PRINTED	TERMS OF SALE	SHIP VIA	F.O.B.	FREIGHT TERMS
04/11/2007				

BID OPENING DATE: **05/02/2007** BID OPENING TIME: **01:30PM**

LINE	QUANTITY	UQP	CAT NO	ITEM NUMBER	UNIT PRICE	AMOUNT
<p>ORIGINAL CONTRACT AND SHALL BE LIMITED TO TWO (2) ONE (1) YEAR PERIODS.</p> <p>CANCELLATION: THE DIRECTOR OF PURCHASING RESERVES THE RIGHT TO CANCEL THIS CONTRACT IMMEDIATELY UPON WRITTEN NOTICE TO THE VENDOR IF THE COMMODITIES AND/OR SERVICE SUPPLIED ARE OF AN INFERIOR QUALITY OR DO NOT CONFORM TO THE SPECIFICATIONS OF THE BID AND CONTRACT HEREIN.</p> <p>OPEN MARKET CLAUSE: THE DIRECTOR OF PURCHASING MAY AUTHORIZE A SPENDING UNIT TO PURCHASE ON THE OPEN MARKET, WITHOUT THE FILING OF A REQUISITION OR COST ESTIMATE, ITEMS SPECIFIED ON THIS CONTRACT FOR IMMEDIATE DELIVERY IN EMERGENCIES DUE TO UNFORESEEN CAUSES (INCLUDING BUT NOT LIMITED TO DELAYS IN TRANSPORTATION OR AN UNANTICIPATED INCREASE IN THE VOLUME OF WORK.)</p> <p>QUANTITIES: QUANTITIES LISTED IN THE REQUISITION ARE APPROXIMATIONS ONLY, BASED ON ESTIMATES SUPPLIED BY THE STATE SPENDING UNIT. IT IS UNDERSTOOD AND AGREED THAT THE CONTRACT SHALL COVER THE QUANTITIES ACTUALLY ORDERED FOR DELIVERY DURING THE TERM OF THE CONTRACT, WHETHER MORE OR LESS THAN THE QUANTITIES SHOWN.</p> <p>ORDERING PROCEDURE: SPENDING UNIT(S) SHALL ISSUE A WRITTEN STATE CONTRACT ORDER (FORM NUMBER WV-39) TO THE VENDOR FOR COMMODITIES COVERED BY THIS CONTRACT. THE ORIGINAL COPY OF THE WV-39 SHALL BE MAILED TO THE VENDOR AS AUTHORIZATION FOR SHIPMENT, A SECOND COPY MAILED TO THE PURCHASING DIVISION, AND A THIRD COPY RETAINED BY THE SPENDING UNIT.</p> <p>BANKRUPTCY: IN THE EVENT THE VENDOR/CONTRACTOR FILES FOR BANKRUPTCY PROTECTION, THIS CONTRACT IS AUTOMATICALLY NULL AND VOID, AND IS TERMINATED WITHOUT FURTHER</p>						

SEE REVERSE SIDE FOR TERMS AND CONDITIONS

SIGNATURE	TELEPHONE	DATE
TITLE	FEIN	ADDRESS CHANGES TO BE NOTED ABOVE

WHEN RESPONDING TO RFQ, INSERT NAME AND ADDRESS IN SPACE ABOVE LABELED 'VENDOR'



State of West Virginia  
 Department of Administration  
 Purchasing Division  
 2019 Washington Street East  
 Post Office Box 50130  
 Charleston, WV 25305-0130

# Request for Quotation

RFQ NUMBER
857C2054

PAGE
3

ADDRESS CORRESPONDENCE TO ATTENTION OF
JOHN JOHNSTON 304-558-2402

RFQ COPY  
 TYPE NAME/ADDRESS HERE

RFQ COPY

SHIP TO

**TraFix Devices Inc.**  
 220 Calle Pintesresco  
 San Clemente, CA 92672

DIVISION OF HIGHWAYS  
 VARIOUS LOCALES AS INDICATED  
 BY ORDER

DATE PRINTED	TERMS OF SALE	SHIP VIA	F.O.B.	FREIGHT TERMS
04/11/2007				

BID OPENING DATE: **05/02/2007** BID OPENING TIME **01:30PM**

LINE	QUANTITY	UOP	CAT NO	ITEM NUMBER	UNIT PRICE	AMOUNT
<p>ORDER.</p> <p>THE TERMS AND CONDITIONS CONTAINED IN THIS CONTRACT SHALL SUPERSEDE ANY AND ALL SUBSEQUENT TERMS AND CONDITIONS WHICH MAY APPEAR ON ANY ATTACHED PRINTED DOCUMENTS SUCH AS PRICE LISTS, ORDER FORMS, SALES AGREEMENTS OR MAINTENANCE AGREEMENTS, INCLUDING ANY ELECTRONIC MEDIUM SUCH AS CD-ROM.</p> <p>REV. 04/11/2001</p> <p>PURCHASING CARD ACCEPTANCE: THE STATE OF WEST VIRGINIA CURRENTLY UTILIZES A VISA PURCHASING CARD PROGRAM WHICH IS ISSUED THROUGH A BANK. THE SUCCESSFUL VENDOR MUST ACCEPT THE STATE OF WEST VIRGINIA VISA PURCHASING CARD FOR PAYMENT OF ALL ORDERS PLACED BY ANY STATE AGENCY FOR ORDERS THAT ARE LESS THAN \$2,500 AS A CONDITION OF AWARD.</p> <p style="text-align: center;">VENDOR PREFERENCE CERTIFICATE</p> <p>CERTIFICATION AND APPLICATION* IS HEREBY MADE FOR PREFERENCE IN ACCORDANCE WITH WEST VIRGINIA CODE, 5A-3-37 (DOES NOT APPLY TO CONSTRUCTION CONTRACTS).</p> <p>A. APPLICATION IS MADE FOR 2.5% PREFERENCE FOR THE REASON CHECKED:</p> <p>( ) BIDDER IS AN INDIVIDUAL RESIDENT VENDOR AND HAS RESIDED CONTINUOUSLY IN WEST VIRGINIA FOR FOUR (4) YEARS IMMEDIATELY PRECEDING THE DATE OF THIS CERTIFICATION; OR</p> <p>( ) BIDDER IS A PARTNERSHIP, ASSOCIATION OR CORPORATION RESIDENT VENDOR AND HAS MAINTAINED ITS HEAD-</p>						

SEE REVERSE SIDE FOR TERMS AND CONDITIONS

SIGNATURE	TELEPHONE	DATE
TITLE	FEIN	ADDRESS CHANGES TO BE NOTED ABOVE

WHEN RESPONDING TO RFQ, INSERT NAME AND ADDRESS IN SPACE ABOVE LABELED 'VENDOR'



State of West Virginia  
 Department of Administration  
 Purchasing Division  
 2019 Washington Street East  
 Post Office Box 50130  
 Charleston, WV 25305-0130

# Request for Quotation

RFQ NUMBER
857C2054

PAGE
4

ADDRESS CORRESPONDENCE TO ATTENTION OF
JOHN JOHNSTON 304-558-2402

RFQ COPY  
 TYPE NAME/ADDRESS HERE

VENDOR

**Trafix Devices Inc.**  
**220 Calle Pintesco**  
**San Clemente, CA 92672**

SHIP TO

DIVISION OF HIGHWAYS  
 VARIOUS LOCALES AS INDICATED  
 BY ORDER

DATE PRINTED	TERMS OF SALE	SHIP VIA	F.O.B.	FREIGHT TERMS
04/11/2007				

BID OPENING DATE: **05/02/2007** BID OPENING TIME **01:30PM**

LINE	QUANTITY	UOP	CAT NO	ITEM NUMBER	UNIT PRICE	AMOUNT
<p>QUARTERS OR PRINCIPAL PLACE OF BUSINESS CONTINUOUSLY IN WEST VIRGINIA FOR FOUR (4) YEARS IMMEDIATELY PRECEDING THE DATE OF THIS CERTIFICATION; OR 80% OF THE OWNERSHIP INTEREST OF BIDDER IS HELD BY ANOTHER INDIVIDUAL, PARTNERSHIP, ASSOCIATION OR CORPORATION RESIDENT VENDOR WHO HAS MAINTAINED ITS HEADQUARTERS OR PRINCIPAL PLACE OF BUSINESS CONTINUOUSLY IN WEST VIRGINIA FOR FOUR (4) YEARS IMMEDIATELY PRECEDING THE DATE OF THIS CERTIFICATION; OR</p> <p>( ) BIDDER IS A CORPORATION NONRESIDENT VENDOR WHICH HAS AN AFFILIATE OR SUBSIDIARY WHICH EMPLOYS A MINIMUM OF ONE HUNDRED STATE RESIDENTS AND WHICH HAS MAINTAINED ITS HEADQUARTERS OR PRINCIPAL PLACE OF BUSINESS WITHIN WEST VIRGINIA CONTINUOUSLY FOR THE FOUR (4) YEARS IMMEDIATELY PRECEDING THE DATE OF THIS CERTIFICATION.</p> <p>B. APPLICATION IS MADE FOR 2.5% PREFERENCE FOR THE REASON CHECKED:</p> <p>( ) BIDDER IS A RESIDENT VENDOR WHO CERTIFIES THAT, DURING THE LIFE OF THE CONTRACT, ON AVERAGE AT LEAST 75% OF THE EMPLOYEES WORKING ON THE PROJECT BEING BID ARE RESIDENTS OF WEST VIRGINIA WHO HAVE RESIDED IN THE STATE CONTINUOUSLY FOR THE TWO YEARS IMMEDIATELY PRECEDING SUBMISSION OF THIS BID; OR.</p> <p>( ) BIDDER IS A NONRESIDENT VENDOR EMPLOYING A MINIMUM OF ONE HUNDRED STATE RESIDENTS OR IS A NONRESIDENT VENDOR WITH AN AFFILIATE OR SUBSIDIARY WHICH MAINTAINS ITS HEADQUARTERS OR PRINCIPAL PLACE OF BUSINESS WITHIN WEST VIRGINIA EMPLOYING A MINIMUM OF ONE HUNDRED STATE RESIDENTS WHO CERTIFIES THAT, DURING THE LIFE OF THE CONTRACT, ON AVERAGE AT LEAST 75% OF THE EMPLOYEES OR BIDDERS' AFFILIATE'S OR</p>						

SEE REVERSE SIDE FOR TERMS AND CONDITIONS

SIGNATURE	TELEPHONE	DATE
TITLE	FEIN	ADDRESS CHANGES TO BE NOTED ABOVE

WHEN RESPONDING TO RFQ, INSERT NAME AND ADDRESS IN SPACE ABOVE LABELED 'VENDOR'



State of West Virginia  
 Department of Administration  
 Purchasing Division  
 2019 Washington Street East  
 Post Office Box 50130  
 Charleston, WV 25305-0130

### Request for Quotation

RFQ NUMBER  
**857C2054**

PAGE  
**5**

ADDRESS CORRESPONDENCE TO ATTENTION OF  
**JOHN JOHNSTON  
 304-558-2402**

VENDOR

RFQ COPY  
 TYPE NAME/ADDRESS HERE

**TraFix Devices Inc.  
 220 Calle Pintesco  
 San Clemente, CA 92672**

SHIP TO

**DIVISION OF HIGHWAYS  
 VARIOUS LOCALES AS INDICATED  
 BY ORDER**

DATE PRINTED	TERMS OF SALE	SHIP VIA	FOB	FREIGHT TERMS
04/11/2007				

BID OPENING DATE: **05/02/2007** BID OPENING TIME **01:30PM**

LINE	QUANTITY	UOP	CAT NO	ITEM NUMBER	UNIT PRICE	AMOUNT
<p>SUBSIDIARY'S EMPLOYEES ARE RESIDENTS OF WEST VIRGINIA WHO HAVE RESIDED IN THE STATE CONTINUOUSLY FOR THE TWO YEARS IMMEDIATELY PRECEDING SUBMISSION OF THIS BID.</p> <p>BIDDER UNDERSTANDS IF THE SECRETARY OF TAX &amp; REVENUE DETERMINES THAT A BIDDER RECEIVING PREFERENCE HAS FAILED TO CONTINUE TO MEET THE REQUIREMENTS FOR SUCH PREFERENCE, THE SECRETARY MAY ORDER THE DIRECTOR OF PURCHASING TO: (A) RESCIND THE CONTRACT OR PURCHASE ORDER ISSUED; OR (B) ASSESS A PENALTY AGAINST SUCH BIDDER IN AN AMOUNT NOT TO EXCEED 5% OF THE BID AMOUNT AND THAT SUCH PENALTY WILL BE PAID TO THE CONTRACTING AGENCY OR DEDUCTED FROM ANY UNPAID BALANCE ON THE CONTRACT OR PURCHASE ORDER.</p> <p>BY SUBMISSION OF THIS CERTIFICATE, BIDDER AGREES TO DISCLOSE ANY REASONABLY REQUESTED INFORMATION TO THE PURCHASING DIVISION AND AUTHORIZES THE DEPARTMENT OF TAX AND REVENUE TO DISCLOSE TO THE DIRECTOR OF PURCHASING APPROPRIATE INFORMATION VERIFYING THAT BIDDER HAS PAID THE REQUIRED BUSINESS TAXES, PROVIDED THAT SUCH INFORMATION DOES NOT CONTAIN THE AMOUNTS OF TAXES PAID NOR ANY OTHER INFORMATION DEEMED BY THE TAX COMMISSIONER TO BE CONFIDENTIAL.</p> <p>UNDER PENALTY OF LAW FOR FALSE SWEARING (WEST VIRGINIA CODE 61-5-3), BIDDER HEREBY CERTIFIES THAT THIS CERTIFICATE IS TRUE AND ACCURATE IN ALL RESPECTS; AND THAT IF A CONTRACT IS ISSUED TO BIDDER AND IF ANYTHING CONTAINED WITHIN THIS CERTIFICATE CHANGES DURING THE TERM OF THE CONTRACT, BIDDER WILL NOTIFY THE PURCHASING DIVISION IN WRITING IMMEDIATELY.</p> <p style="text-align: right;">BIDDER: -----</p>						

SEE REVERSE SIDE FOR TERMS AND CONDITIONS

SIGNATURE	TELEPHONE	DATE
TITLE	FEIN	ADDRESS CHANGES TO BE NOTED ABOVE

WHEN RESPONDING TO RFQ, INSERT NAME AND ADDRESS IN SPACE ABOVE LABELED 'VENDOR'



State of West Virginia  
 Department of Administration  
 Purchasing Division  
 2019 Washington Street East  
 Post Office Box 50130  
 Charleston, WV 25305-0130

# Request for Quotation

RFQ NUMBER  
**857C2054**

PAGE  
**6**

ADDRESS CORRESPONDENCE TO ATTENTION OF:  
**JOHN JOHNSTON**  
**304-558-2402**

VENDOR

RFQ COPY  
 TYPE NAME/ADDRESS HERE

**TraFFix Devices Inc.**  
**220 Calle Pintesresco**  
**San Clemente, CA 92672**

SHIP TO

**DIVISION OF HIGHWAYS**  
**VARIOUS LOCALES AS INDICATED**  
**BY ORDER**

DATE PRINTED	TERMS OF SALE	SHIP VIA	F.O.B.	FREIGHT TERMS
04/11/2007				

BID OPENING DATE: **05/02/2007** BID OPENING TIME **01:30PM**

LINE	QUANTITY	UQP	CAT NO	ITEM NUMBER	UNIT PRICE	AMOUNT
<p>DATE: -----</p> <p>SIGNED: -----</p> <p>TITLE: -----</p> <p>* CHECK ANY COMBINATION OF PREFERENCE CONSIDERATION(S) IN EITHER "A" OR "B", OR BOTH "A" AND "B" WHICH YOU ARE ENTITLED TO RECEIVE. YOU MAY REQUEST UP TO THE MAXIMUM 5% PREFERENCE FOR BOTH "A" AND "B". (REV. 12/00)</p> <p>NOTICE</p> <p>A SIGNED BID MUST BE SUBMITTED TO:</p> <p>DEPARTMENT OF ADMINISTRATION            PURCHASING DIVISION            BUILDING 15            2019 WASHINGTON STREET, EAST            CHARLESTON, WV 25305-0130</p> <p>THE BID SHOULD CONTAIN THIS INFORMATION ON THE FACE OF THE ENVELOPE OR THE BID MAY NOT BE CONSIDERED:</p> <p>SEALED BID</p> <p>BUYER: _____ CAT NO: <b>33</b></p>						

SEE REVERSE SIDE FOR TERMS AND CONDITIONS

SIGNATURE	TELEPHONE	DATE
TITLE	FEIN	ADDRESS CHANGES TO BE NOTED ABOVE

WHEN RESPONDING TO RFQ, INSERT NAME AND ADDRESS IN SPACE ABOVE LABELED 'VENDOR'



State of West Virginia  
 Department of Administration  
 Purchasing Division  
 2019 Washington Street East  
 Post Office Box 50130  
 Charleston, WV 25305-0130

**Request for  
 Quotation**

RFQ NUMBER
857C2054

PAGE
7

ADDRESS CORRESPONDENCE TO ATTENTION OF:
JOHN JOHNSTON 304-558-2402

VENDOR

RFQ COPY  
 TYPE NAME/ADDRESS HERE

SHIP TO

DIVISION OF HIGHWAYS  
 VARIOUS LOCALES AS INDICATED  
 BY ORDER

**TraFix Devices Inc.**  
 220 Calle Pintoresco  
 San Clemente, CA 92672

DATE PRINTED	TERMS OF SALE	SHIP VIA	F.O.B.	FREIGHT TERMS
04/11/2007				

BID OPENING DATE: **05/02/2007** BID OPENING TIME **01:30PM**

LINE	QUANTITY	UOP	CAT NO.	ITEM NUMBER	UNIT PRICE	AMOUNT
RFQ. NO.:			857C2054			
BID OPENING DATE AND TIME						
PLEASE PROVIDE A FAX NUMBER IN CASE IT IS NECESSARY TO CONTACT YOU REGARDING YOUR BID:						
----- 949.361.9205 -----						
CONTACT PERSON (PLEASE PRINT CLEARLY):						
----- JULIE EDWARDS -----						
***** THIS IS THE END OF RFQ 857C2054 ***** TOTAL:						232,256.60

SEE REVERSE SIDE FOR TERMS AND CONDITIONS

SIGNATURE	TELEPHONE	DATE
<i>[Signature]</i>	949.361.5063	949.361.9205
TITLE	ADDRESS CHANGES TO BE NOTED ABOVE	
CONTRACTS SPECIALIST 3302178 24		

WHEN RESPONDING TO RFQ, INSERT NAME AND ADDRESS IN SPACE ABOVE LABELED 'VENDOR'

## **SCOPE OF CONTRACT**

The purpose of this Contract shall be to supply compact, portable sign stands and highly reflective roll-up signs, as required, to various West Virginia Division of Highways (WVDOH) personnel.

## **COMPACT PORTABLE SIGN STANDS - SPECIFICATIONS**

All stands bid shall be approved in accordance with the requirements of the National Cooperative Highway Research Program (NCHRP) Report 350 when utilized as described herein.

Compact, portable sign stands shall be capable of holding 36" and 48" roll-up signs a minimum of 12" off the ground. It shall have 4 (four) legs capable of telescoping in or out to utilize both 36" and 48" diamond shaped signs. Each leg, when telescoped out, shall positively lock into the extended position by way of a stainless steel "push" button type mechanism. Each leg shall have three (3) positive locking positions; vertical for storage, and two additional horizontal positions for adjustment on uneven terrain. Legs shall be manufactured for long life utilizing aluminum.

The frame, spring(s), and mast of the stand shall be fabricated of steel, or other approved material, and have the ability to flex if necessary, allowing the complete assembly to have additional wind spilling capability beyond that which is provided by the sign ribs. These components shall be stainless, electro-deposit zinc coated, hot-dip galvanized, powder coated steel, or other approved long life material.

The stand mast shall hold the sign in position by clamping onto the vertical rib of the sign. The clamping device shall accommodate all of the vertical rib sizes detailed as part of this Contract. The clamping device shall be designed such that the sign may be inserted into position using two hands with the clamping device open, and be quickly tightened into place thereafter. Both cam type and screw-in type will be considered, in addition to other similar acceptable designs. Screw-in type mechanisms shall include a tightening knob that may be easily operated in a fast manner, without requiring an excessive number of rotations to tighten.

The stand shall not be excessively heavy, bulky, or cumbersome, as determined by the office and field staff involved in the evaluation of stands submitted for consideration.

The overall "footprint" of the stand with the legs in the retracted and extended positions shall not be excessive, as determined by the office and field staff involved in the evaluation of stands submitted for consideration. The side-to-side dimension of the footprint is critical due to shoulder width considerations, and generally should be limited to 36" in the retracted position, and 60" in the extended position.

The end of each stand leg shall be equipped with a permanently affixed tip manufactured of rubber, or other similar approved material, to deter the stand from "walking".



When using a 36" diamond roll-up sign in the retracted leg position, or when using a 48" diamond roll-up sign in the extended leg position, the stand shall remain upright and shall not require any additional ballasting in wind gusts created by 55 MPH and 70 MPH speed limit traffic, respectively. The stand shall be significantly stiff to prevent excessive swaying and twisting of the sign.

All stands shall include a resting or stop point on the mast for the bottom of the vertical mast at which point the bottom of the sign will be at a 12" (min) mounting height above the surface that the stand is resting on.

The successful vendor shall provide a four (4) year warranty against defects in workmanship, parts, and materials on all stands supplied as part of this Contract.

All potential stands to be bid as part of this Contract shall be submitted prior to advertisement for reviews to be performed by Traffic Engineering central office staff and select maintenance personnel. Stands that are reviewed and determined to meet the requirements specified above shall be listed within this Contract below, and will be the only stands considered for award as part of bids submitted for this Contract.

#### **COMPACT PORTABLE SIGN STANDS – APPROVED PRODUCTS**

Based on the results of reviews conducted by Traffic Engineering central office staff, and select maintenance personnel, the following manufacturer / model stands have been approved for bidding on this Contract. Bids on the stand portion of this Contract must specify one of the following models as the stand to be supplied to be considered for award:

- Dicke Tool Uniflex 2000 Sign Stand – **Model UF2000** with aluminum legs, single steel spring, and screw-in universal sign attachment bracket.
- MDI Economy WindMaster Sign Stand – **Model 4814SSCKHDK** with aluminum legs, single steel spring, and CamLock cam-type universal sign attachment bracket.
- Eastern Metal-USA Sign - **Model C-902-DDQA** with aluminum legs
- Korman Signs – **Model SS548UCA** with alum legs, universal latching mechanism with large grip handle, and foot release kick plates.

**ALUMINUM SUBSTRATE SIGN AND LARGE ROLL-UP SIGN PORTABLE  
SIGN STANDS – SPECIFICATIONS**

All stands bid shall be approved in accordance with the requirements of the National Cooperative Highway Research Program (NCHRP) Report 350 when utilized as described herein.

Aluminum substrate sign and large roll-up sign portable sign stands shall be capable of holding 0.080 aluminum 48" diamond signs, 48" octagon signs, 48" triangle signs, 36x60 vertical rectangle signs, 60x30 horizontal rectangle signs, and smaller signs, as well as roll-up signs as large as 60x60 square. The stand shall be designed such that the sign mounting height will be 12-24 in off of the ground. Stands designed for higher mounting heights (i.e. 5' or 7') shall not be allowed. The stand shall have 4 (four) legs. Each leg shall have three (3) positive locking positions; vertical for storage, and two additional horizontal positions for adjustment on uneven terrain. Legs shall be manufactured for long life utilizing either aluminum or galvanized steel.

The frame, spring(s), and mast of the stand shall be fabricated of steel, or other approved material, and have the ability to flex if necessary, allowing the stand to provide all wind spilling capability for aluminum signs, and additional wind spilling capability beyond that which is provided by the sign ribs for roll-up signs. These components shall be stainless, electro-deposit zinc coated, hot-dip galvanized, powder coated steel, or other approved long life material.

The stand provided shall include all components necessary for installing all of the signs referenced above, including an adjustable mast, all adjustable aluminum sign brackets, and an adjustable roll-up sign bracket. The roll-up sign bracket shall accommodate all of the horizontal rib sizes detailed as part of this Contract.

The stand shall not be excessively heavy, bulky, or cumbersome.

The overall "footprint" of the stand shall not be excessive. The side-to-side dimension of the footprint is critical due to shoulder width considerations, and generally should be limited to 48". The end-to-end dimension of the footprint should generally be limited to 96".

The successful vendor shall provide a four (4) year warranty against defects in workmanship, parts, and materials on all stands supplied as part of this Contract.

Stands that are reviewed and determined to meet the requirements specified above shall be listed within this Contract below, and will be the only stands considered for award as part of bids submitted for this Contract.

### **ALUMINUM SUBSTRATE SIGN AND LARGE ROLL-UP SIGN PORTABLE SIGN STANDS – APPROVED PRODUCTS**

Due to the restricted time frame available for evaluation of stands of this type, only literature provided by potential manufacturers of this type stand was reviewed.

Additionally, consideration was limited to manufacturers whose Compact Portable Sign Stands were approved for bidding, as noted above. Bids on the stand portion of this Contract must specify one of the following models as the stand to be supplied to be considered for award:

- Eastern Metal-USA Sign - **Model X553DD**
- Korman Signs – **Model SS548E**

### **SIGN FABRICATION STANDARDS**

Note, in regards to all references below to the “WVDOH Sign Fabrication Details”, these references shall be interpreted as referring to the manual “West Virginia Division of Highways, Sign Fabrication Details, Traffic Engineering Division, September 2005”, and all subsequent supplements.

### **ROLL-UP SIGN SHEETING**

All signs and plaques supplied as part of this Contract shall be manufactured using 3M RS20 (white) and RS24 (fl-orange) sheeting, as applicable, with manufacturer approved inks. The sheeting shall be warranted by the 3M Company for its’ intended use and shall meet the minimum warranted retroreflective values stated by 3M, subject to the provisions stated on the 3M Product Bulletin.

### **ROLL-UP SHEETING SPLICES**

In cases where the splicing of roll-up sign material fabric is required as noted below, the splice shall be accomplished by the following method:

- The seam shall be continuously “bridged” on the back side of the sign by a 4” (min) wide strip of 18oz Cooley fabric coated with 200mp adhesive.
- The seam shall be stitched on both the front and back faces of the sign.
- The seam shall be bar tacked on both the front and back faces of the sign on each end of the seam.

### **GENERAL SIGN FABRICATION SPECIFICATIONS**

All signs supplied shall have one or more permanently affixed vertical fiberglass ribs, with at least one along the vertical centerline of the sign. The vertical ribs of all signs shall be attached to the sign face with a minimum of two metal fasteners, one each at the top and bottom. These fasteners shall include a plastic or nylon washer between the fastener and both faces of the sign. The vertical rib fastener bolts shall not be excessively long, and may protrude only slightly past the end of the bolt nut.

All horizontal or diagonal ribs shall be designed to pivot about a metallic pivot point located along the vertical rib. The ends of the metallic pivot shall be smooth without any exposed sharp edges. The ends of the horizontal/diagonal ribs on all signs shall slide into a solid, non-sliding, polycarbonate (or other similar approved material) corner pocket mounted at the edge of the sign. The corner pockets shall fasten to the sign face using two or more fasteners each. The corner pockets shall be designed for the size ribs supplied, without requiring modification to the ribs, and shall be in general conformance with the attached sample detail drawings.

When specified (see bid item listing), two 18" x 18" non-reflective fluorescent orange vinyl flags shall be permanently attached to the top of the vertical rib that is along the vertical centerline of the sign. The system for deploying the flags shall be a good quality, long lasting, reliable system. All metal parts of the system shall be stainless, electro-deposit zinc coated, hot-dip galvanized, or powder coated steel. Flag staffs should be fiberglass, similar to the sign ribs, and have a minimum section modulus equal to that of a 1/8" thick x 1" wide rib ( $0.002604 \text{ in}^3$ ). The staffs shall be sufficiently long enough to hold the flags completely above the sign face. No hand tightening of any components shall be required to hold the flags in the deployed position. When deployed, the two flags shall extend symmetrically (about the vertical centerline) up and out from their mounting point along the vertical rib, with the flags held in position completely above the sign face, and with each staff at an angle of 30 to 60 degrees from the vertical centerline of the sign. Staff mounting and deployment systems shall be subject to review and approval.

For particular signs (see bid item listing) and all overlay plaques requiring velcro strips to be attached for temporary overlay attachment, the hook ("coarse") side of the velcro shall be attached to the sign faces. The loop ("fuzzy") side of the velcro shall be attached to the back face of the overlays.

All signs must present a finished, professional look to the motorist with no sagging of the sign material. Signs shall include anti-kite velcro loops attached to the back faces of the signs and to be connected around the ribs of the signs (quantity and general position of loops shall be noted herein). An additional length of velcro shall be fastened near the vertical center of one of the horizontal end points on each sign, and shall be oriented such that when the sign is rolled up on the vertical rib the velcro will encircle the sign and hold it in the rolled up storing position.

All roll-up signs shall have a permanent sticker affixed to the non-reflective face with the wording "PROPERTY OF WVDOH" in 1/2" minimum legend size.

The successful vendor shall provide a one (1) year warranty against defects in workmanship, parts, and materials (with the exception of that which is covered under the 3M warranty) on all signs supplied as part of this Contract.

**ADDITIONAL SPECIFICATIONS FOR BID ITEM 3**

Signs supplied as part of Bid Item 3 shall be per the WVDOH Sign Fabrication Details, fabrication number R1-1, 36", and shall be octagonal in shape. Rib sizes, rib locations, rib lengths, corner pocket locations, rotation point location, and anti-kite velcro strip locations shall be in substantial conformance as shown in the attached drawing "36" OCTAGON – CORNER POCKET AND RIB CONFIGURATION".

**ADDITIONAL SPECIFICATIONS FOR BID ITEM 4**

Signs supplied as part of Bid Item 4 shall be per the WVDOH Sign Fabrication Details, fabrication number R1-1, 48", and shall be octagonal in shape. Rib sizes, rib locations, rib lengths, corner pocket locations, rotation point location, and anti-kite velcro strip locations shall be in substantial conformance as shown in the attached drawing "48" OCTAGON – CORNER POCKET AND RIB CONFIGURATION".

**ADDITIONAL SPECIFICATIONS FOR BID ITEM 5**

Signs supplied as part of Bid Item 5 shall be per the WVDOH Sign Fabrication Details, fabrication number W3-1M, 36". An orange background shall be used. The symbol may be glued or sewn onto the sign face separately. Rib sizes, rib locations, rib lengths, corner pocket locations, rotation point location, and anti-kite velcro strip locations shall be in substantial conformance as shown in the attached drawing "36" DIAMOND – CORNER POCKET AND RIB CONFIGURATION".

**ADDITIONAL SPECIFICATIONS FOR BID ITEM 6**

Signs supplied as part of Bid Item 6 shall be per the WVDOH Sign Fabrication Details, fabrication number W3-1M, 48". An orange background shall be used. The symbol may be glued or sewn onto the sign face separately. Rib sizes, rib locations, rib lengths, corner pocket locations, rotation point location, and anti-kite velcro strip locations shall be in substantial conformance as shown in the attached drawing "48" DIAMOND – CORNER POCKET AND RIB CONFIGURATION".

**ADDITIONAL SPECIFICATIONS FOR BID ITEM 7**

Signs supplied as part of Bid Item 7 shall be per the WVDOH Sign Fabrication Details, fabrication number R1-2, 36", and shall be triangular in shape. Rib sizes, rib locations, rib lengths, corner pocket locations, rotation point location, and anti-kite velcro strip locations shall be in substantial conformance as shown in the attached drawing "36" TRIANGLE – CORNER POCKET AND RIB CONFIGURATION".

**ADDITIONAL SPECIFICATIONS FOR BID ITEM 8**

Signs supplied as part of Bid Item 8 shall be per the WVDOH Sign Fabrication Details, fabrication number R1-2, 48", and shall be triangular in shape. Rib sizes, rib locations, rib lengths, corner pocket locations, rotation point location, and anti-kite velcro strip locations shall be in substantial conformance as shown in the attached drawing "48" **TRIANGLE – CORNER POCKET AND RIB CONFIGURATION**".

**ADDITIONAL SPECIFICATIONS FOR BID ITEM 9**

Signs supplied as part of Bid Item 9 shall be per the WVDOH Sign Fabrication Details, fabrication number W3-2M, 36". An orange background shall be used. The symbol may be glued or sewn onto the sign face separately. Rib sizes, rib locations, rib lengths, corner pocket locations, rotation point location, and anti-kite velcro strip locations shall be in substantial conformance as shown in the attached drawing "36" **DIAMOND – CORNER POCKET AND RIB CONFIGURATION**".

**ADDITIONAL SPECIFICATIONS FOR BID ITEM 10**

Signs supplied as part of Bid Item 10 shall be per the WVDOH Sign Fabrication Details, fabrication number W3-2M, 48". An orange background shall be used. The symbol may be glued or sewn onto the sign face separately. Rib sizes, rib locations, rib lengths, corner pocket locations, rotation point location, and anti-kite velcro strip locations shall be in substantial conformance as shown in the attached drawing "48" **DIAMOND – CORNER POCKET AND RIB CONFIGURATION**".

**ADDITIONAL SPECIFICATIONS FOR BID ITEM 11**

Signs supplied as part of Bid Item 11 shall be per the attached drawing "BID ITEM 11 **MODIFIED STANDARD DETAIL**". Overall size shall be 36"x60". All text shall be black. The background above the horizontal border shall be orange. The background below the horizontal border shall be white. The seam between the upper (orange background) and bottom (white background) portions of the sign shall be sewn along the black border in the manner specified above in the **ROLL-UP SHEETING SPLICES** section. No numerals shall be screened onto the sign face. 2 ea. 28" long x 1" (min) wide pieces of velcro shall be glued or sewn onto the sign face, as shown on the attached modified standard detail, to facilitate the attachment of the interchangeable numerals to be supplied as part of Bid Item 12. Rib sizes, rib locations, rib lengths, corner pocket locations, rotation point location, and anti-kite velcro strip locations shall be in substantial conformance as shown in the attached drawing "36X60 **VERTICAL RECTANGLE – CORNER POCKET AND RIB CONFIGURATION**".

**ADDITIONAL SPECIFICATIONS FOR BID ITEM 12**

Items supplied as part of Bid Item 12 shall be individual numeral plaques intended to be attached to the face of signs supplied under Bid Item 11. The numeral portions of the plaques shall be black, and the background portions shall be white. The overall size of each individual plaque shall be 17" tall x 14" wide. Numerals shall be 15" Series E, and shall be centered vertically and horizontally in each plaque. 2 ea. 14" long x 1" (min) wide pieces of velcro shall be glued or sewn onto the back face of each plaque, with 1 ea. of the pieces along the top and bottom edges of the plaque, and with the outside edge of each piece along the outside edge of the plaque. Orders will specify the quantity of each individual numeral to be supplied.

**ADDITIONAL SPECIFICATIONS FOR BID ITEM 13**

Signs supplied as part of Bid Item 13 shall be per the attached drawing "BID ITEM 13 MODIFIED STANDARD DETAIL". The text, arrow shaft, and border portions of the sign shall be black, and the background portion shall be white. 4 ea. 8" long x 1" (min) wide pieces of white velcro shall be glued or sewn onto the sign face, as shown on the attached detail, to facilitate the attachment of the included detachable arrow head as described below. Rib sizes, rib locations, rib lengths, corner pocket locations, rotation point location, and anti-kite velcro strip locations shall be in substantial conformance as shown in the attached drawing "48X24 HORIZONTAL RECTANGLE - CORNER POCKET AND RIB CONFIGURATION".

With each of the signs supplied as part of this bid item, 1 ea. separate arrow head plaque, as detailed on the above referenced modified standard detail, intended to be attached to the face of the sign shall be supplied. 2 ea. 8" long x 1" (min) wide pieces of velcro shall be glued or sewn onto the back face of each plaque, with 1 ea. of the pieces along the top and bottom edges of the plaque, and with the outside edge of each piece along the outside edge of the plaque. The arrow head and shaft portions of the plaque shall be black, and the background portion shall be white.

**ADDITIONAL SPECIFICATIONS FOR BID ITEM 14**

Signs supplied as part of Bid Item 14 shall be per the WVD OH Sign Fabrication Details, fabrication number R4-7B, 24"X30". Rib sizes, rib locations, rib lengths, corner pocket locations, rotation point location, and anti-kite velcro strip locations shall be in substantial conformance as shown in the attached drawing "24X30 VERTICAL RECTANGLE - CORNER POCKET AND RIB CONFIGURATION".

**ADDITIONAL SPECIFICATIONS FOR BID ITEM 15**

Signs supplied as part of Bid Item 15 shall be per the WVD OH Sign Fabrication Details, fabrication number R4-7B, 36"X48". Rib sizes, rib locations, rib lengths, corner pocket locations, rotation point location, and anti-kite velcro strip locations shall be in substantial conformance as shown in the attached drawing "36X48 VERTICAL RECTANGLE - CORNER POCKET AND RIB CONFIGURATION".

**ADDITIONAL SPECIFICATIONS FOR BID ITEM 16**

Signs supplied as part of Bid Item 16 shall be per the WVDOH Sign Fabrication Details, fabrication number R9-9. Rib sizes, rib locations, rib lengths, corner pocket locations, rotation point location, and anti-kite velcro strip locations shall be in substantial conformance as shown in the attached drawing "30X18 HORIZONTAL RECTANGLE – CORNER POCKET AND RIB CONFIGURATION".

**ADDITIONAL SPECIFICATIONS FOR BID ITEM 17**

Signs supplied as part of Bid Item 17 shall be per the attached drawing "BID ITEM 17 MODIFIED STANDARD DETAIL". The text and border portions of the sign shall be black, and the background portion shall be white. 2 ea. 39" long x 1" wide pieces of white velcro shall be glued or sewn onto the sign face, as shown on the attached modified standard detail, to facilitate the attachment of the interchangeable "BRIDGE" and "RAMP" plaques to be supplied as part of Bid Item 18. Rib sizes, rib locations, rib lengths, corner pocket locations, rotation point location, and anti-kite velcro strip locations shall be in substantial conformance as shown in the attached drawing "48x30 HORIZONTAL RECTANGLE – CORNER POCKET AND RIB CONFIGURATION".

**ADDITIONAL SPECIFICATIONS FOR BID ITEM 18**

Items supplied as part of Bid Item 18 shall be individual message "BRIDGE" and "RAMP" plaques intended to be attached to the face of signs supplied under Bid Item 17. The text portions of the plaques shall be black, and the background portions shall be white. The overall size of each individual plaque shall be 10" tall x 39" wide. Text shall be 8" Series D, and shall be centered vertically and horizontally in each plaque. 2 ea. 39" long x 1" wide pieces of velcro shall be glued or sewn onto the back face of each plaque, with 1 ea. of the pieces along the top and bottom edges of the plaque, and with the outside edge of each piece along the outside edge of the plaque. Orders will specify the quantity of each individual message ("BRIDGE" and "RAMP") to be supplied.

**ADDITIONAL SPECIFICATIONS FOR BID ITEM 19**

Signs supplied as part of Bid Item 19 shall be per the attached drawing "BID ITEM 19 MODIFIED STANDARD DETAIL". The text and border portions of the sign shall be black, and the background portion shall be white. No numerals shall be screened onto the sign face. 2 ea. 10" long x 1" (min) wide pieces of white velcro shall be glued or sewn onto the sign face, as shown on the attached modified standard detail, to facilitate the attachment of the interchangeable numeral plaques to be supplied as part of Bid Item 20. Rib sizes, rib locations, rib lengths, corner pocket locations, rotation point location, and anti-kite velcro strip locations shall be in substantial conformance as shown in the attached drawing "60x30 HORIZONTAL RECTANGLE – CORNER POCKET AND RIB CONFIGURATION".



**ADDITIONAL SPECIFICATIONS FOR BID ITEM 20**

Items supplied as part of Bid Item 20 shall be individual numeral plaques intended to be attached to the face of signs supplied under Bid Item 19. The numeral portions of the plaques shall be black, and the background portions shall be white. The overall size of each individual plaque shall be 7" tall x 5" wide. Numerals shall be 5" Series C, and shall be centered vertically and horizontally in each plaque. 2 ea. 5" long x 1" (min) wide pieces of velcro shall be glued or sewn onto the back face of each plaque, with 1 ea. of the pieces along the top and bottom edges of the plaque, and with the outside edge of each piece along the outside edge of the plaque. Orders will specify the quantity of each individual numeral to be supplied.

**ADDITIONAL SPECIFICATIONS FOR BID ITEM 21**

Signs supplied as part of Bid Item 21 shall be per the WVDOH Sign Fabrication Details, fabrication number R11-4. Rib sizes, rib locations, rib lengths, corner pocket locations, rotation point location, and anti-kite velcro strip locations shall be in substantial conformance as shown in the attached drawing "60x30 HORIZONTAL RECTANGLE - CORNER POCKET AND RIB CONFIGURATION".

**ADDITIONAL SPECIFICATIONS FOR BID ITEM 22**

Signs supplied as part of Bid Item 22 shall be per the attached drawing "BID ITEM 22 MODIFIED STANDARD DETAIL". The text and border portions of the sign shall be black, and the background portion shall be orange. 2 ea. 26-1/2" long x 1" (min) wide pieces of velcro shall be glued or sewn onto the sign face, as shown on the attached modified standard detail, to facilitate the attachment of the interchangeable message plaques to be supplied as part of Bid Item 23. Rib sizes, rib locations, rib lengths, corner pocket locations, rotation point location, and anti-kite velcro strip locations shall be in substantial conformance as shown in the attached drawing "48x36 HORIZONTAL RECTANGLE - CORNER POCKET AND RIB CONFIGURATION".

**ADDITIONAL SPECIFICATIONS FOR BID ITEM 23**

Items supplied as part of Bid Item 23 shall be individual message plaques intended to be attached to the face of signs supplied under Bid Item 22. The text portions of the plaques shall be black, and the background portions shall be orange. The overall size of each individual plaque shall be 10" tall x 26-1/2" wide. Text shall be 8" Series D, and shall be centered vertically and horizontally in each plaque. 2 ea. 26-1/2" long x 1" (min) wide pieces of velcro shall be glued or sewn onto the back face of each plaque, with 1 ea. of the pieces along the top and bottom edges of the plaque, and with the outside edge of each piece along the outside edge of the plaque. Orders will specify the quantity of each individual message ("OPEN" and "CLOSED") to be supplied.

**ADDITIONAL SPECIFICATIONS FOR BID ITEM 24**

Signs supplied as part of Bid Item 24 shall be per the WVDOH Sign Fabrication Details, fabrication number W22-11. The text and border portions of the sign shall be black, and the background portion of the sign shall be orange. One vertical seam located 12" from the left (front face) edge of the sign will be allowed. The seam shall be manufactured in the manner specified above in the **ROLL-UP SHEETING SPLICES** section. Rib sizes, rib locations, rib lengths, corner pocket locations, rotation point location, and anti-kite velcro strip locations shall be in substantial conformance as shown in the attached drawing "**60X60 SQUARE – CORNER POCKET AND RIB CONFIGURATION**". In addition to the above specified "PROPERTY OF WVDOH" sticker, signs supplied under this bid item shall also have an additional prominently displayed sticker permanently affixed to the back face near the center with the following text in 1" letter size:

**"NOTICE: THIS SIGN IS NOT TO BE INSTALLED USING A COMPACT SIGN STAND. CONTACT DT AT 558-3063 FOR FURTHER CLARIFICATION"**

**ADDITIONAL SPECIFICATIONS FOR BID ITEM 25**

Signs supplied as part of Bid Item 25 shall be per the attached drawing "**BID ITEM 25 MODIFIED STANDARD DETAIL**". The text and border portions of the sign shall be black, and the background portion shall be orange. 8 ea. 5" long x ½" wide pieces of velcro shall be glued or sewn onto the sign face, as shown on the attached modified standard detail, to facilitate the attachment of the arrow overlay plaque as described below. Rib sizes, rib locations, rib lengths, corner pocket locations, rotation point location, and anti-kite velcro strip locations shall be in substantial conformance as shown in the attached drawing "**30X24 HORIZONTAL RECTANGLE – CORNER POCKET AND RIB CONFIGURATION**".

With each of the signs supplied as part of this bid item, 1 ea. separate arrow head plaque, as detailed on the above referenced modified standard detail, intended to be attached to the face of the sign shall be supplied. 4 ea. 5" long x ½" wide pieces of velcro shall be glued or sewn onto the back face of each plaque as shown on the modified standard detail. The arrow head and shaft portions of the plaque shall be black, and the background portion shall be orange.

### **ADDITIONAL SPECIFICATIONS FOR BID ITEM 26**

Signs supplied as part of Bid Item 26 shall be per the attached drawing "**BID ITEM 26 MODIFIED STANDARD DETAIL**". The text and border portions of the sign shall be black, and the background portion shall be orange. "DETOUR" text size shall be 7" Series D. Border shall be 1.25". Margin shall be 0.75". Corner Radius shall be 3". 2 ea. 41-1/2" long x 1" (min) wide pieces of orange velcro shall be glued or sewn onto the sign face, as shown on the attached modified standard detail, to facilitate the attachment of the interchangeable overlay plaques to be supplied as part of Bid Items 27 and 28. 8 ea. 6" long x 1/2" wide pieces of velcro shall be glued or sewn onto the sign face, as shown on the attached modified standard detail, to facilitate the attachment of the arrow overlay plaque as described below. Rib sizes, rib locations, rib lengths, corner pocket locations, rotation point location, and anti-kite velcro strip locations shall be in substantial conformance as shown in the attached drawing "**48x48 SQUARE - CORNER POCKET AND RIB CONFIGURATION**".

With each of the signs supplied as part of this bid item, 1 ea. separate arrow head plaque, as detailed on the above referenced modified standard detail, intended to be attached to the face of the sign shall be supplied. 4 ea. 6" long x 1/2" wide pieces of velcro shall be glued or sewn onto the back face of each plaque as shown on the modified standard detail. The arrow head and shaft portions of the plaque shall be black, and the background portion shall be orange.

### **ADDITIONAL SPECIFICATIONS FOR BID ITEM 27**

Items supplied as part of Bid Item 27 shall be individual route plaques intended to be attached to the face of signs supplied under Bid Item 26. The text portions of the plaques shall be black, and the background portions shall be orange. The overall size of each individual plaque shall be 9" tall x 28" wide. Text shall be 8" Series D, or, if necessary, 8" Series C as required for 3 digit routes. Text shall be centered vertically and horizontally in each plaque. Format of text shall be "Route Classification"- "Hyphen"- "Route Number" (i.e. "US-119", "WV-2", "I-79", etc.). 2 ea. 28" long x 1" (min) wide pieces of velcro shall be glued or sewn onto the back face of each plaque, with 1 ea. of the pieces along the top and bottom edges of the plaque, and with the outside edge of each piece along the outside edge of the plaque. Orders will specify the quantity of each individual route plaque to be supplied.

### **ADDITIONAL SPECIFICATIONS FOR BID ITEM 28**

Items supplied as part of Bid Item 28 shall be individual cardinal direction plaques intended to be attached to the face of signs supplied under Bid Item 26. The text portions of the plaques shall be black, and the background portions shall be orange. The overall size of each individual plaque shall be 9" tall x 7" wide. Text shall be 8" Series D. Text shall be centered vertically and horizontally in each plaque. 2 ea. 7" long x 1" (min) wide pieces of velcro shall be glued or sewn onto the back face of each plaque, with 1 ea. of the pieces along the top and bottom edges of the plaque, and with the outside edge of each piece along the outside edge of the plaque. Orders will specify the quantity of each individual plaque ("N", "S", "E", and "W") to be supplied.

**ADDITIONAL SPECIFICATIONS FOR BID ITEM 29**

Items supplied as part of Bid Item 29 shall be standard message (as shown in the WVDOH Sign Fabrication Details) orange and black 48"x48" diamond shaped construction zone warning signs. The text portions of the signs shall be black, and the background portions shall be orange. Rib sizes, rib locations, rib lengths, corner pocket locations, rotation point location, and anti-kite velcro strip locations shall be in substantial conformance as shown in the attached drawing "**48" DIAMOND – CORNER POCKET AND RIB CONFIGURATION**". Orders will specify the quantity of each fabrication number to be supplied.

**ADDITIONAL SPECIFICATIONS FOR BID ITEM 30**

Items supplied as part of Bid Item 30 shall be standard message (as shown in the WVDOH Sign Fabrication Details) orange and black 48"x48" diamond shaped construction zone warning signs, with the addition of 2 ea. 18" x 18" non-reflective fluorescent orange vinyl flags, as specified above. The text portions of the signs shall be black, and the background portions shall be orange. Rib sizes, rib locations, rib lengths, corner pocket locations, rotation point location, and anti-kite velcro strip locations shall be in substantial conformance as shown in the attached drawing "**48" DIAMOND – CORNER POCKET AND RIB CONFIGURATION**". Orders will specify the quantity of each fabrication number to be supplied.

**ADDITIONAL SPECIFICATIONS FOR BID ITEM 31**

Items supplied as part of Bid Item 31 shall be standard message (as shown in the WVDOH Sign Fabrication Details) orange and black 36"x36" diamond shaped construction zone warning signs. The text portions of the signs shall be black, and the background portions shall be orange. Rib sizes, rib locations, rib lengths, corner pocket locations, rotation point location, and anti-kite velcro strip locations shall be in substantial conformance as shown in the attached drawing "**36" DIAMOND – CORNER POCKET AND RIB CONFIGURATION**". Orders will specify the quantity of each fabrication number to be supplied.

**ADDITIONAL SPECIFICATIONS FOR BID ITEM 32**

Items supplied as part of Bid Item 32 shall be standard message (as shown in the WVDOH Sign Fabrication Details) orange and black 36"x36" diamond shaped construction zone warning signs, with the addition of 2 ea. 18" x 18" non-reflective fluorescent orange vinyl flags, as specified above. The text portions of the signs shall be black, and the background portions shall be orange. Rib sizes, rib locations, rib lengths, corner pocket locations, rotation point location, and anti-kite velcro strip locations shall be in substantial conformance as shown in the attached drawing "**36" DIAMOND – CORNER POCKET AND RIB CONFIGURATION**". Orders will specify the quantity of each fabrication number to be supplied.

### **ADDITIONAL SPECIFICATIONS FOR BID ITEM 33**

Items supplied as part of Bid Item 33 shall be standard message (as shown in the WVDOH Sign Fabrication Details) orange and black 48"x48" diamond shaped construction zone warning signs, with the addition of 2 to 4 ea. 28" long x 1/2" wide orange velcro strips to be glued or sewn onto the sign face. The velcro strips shall be installed horizontally and parallel to one another, with the measured distance between the outside edges of the strips to be 8". The mid-point along (14") and between (4") the strips shall be centered vertically and horizontally about the portion of text in the sign specified. The text portions of the signs shall be black, and the background portions shall be orange. Rib sizes, rib locations, rib lengths, corner pocket locations, rotation point location, and anti-kite velcro strip locations shall be in substantial conformance as shown in the attached drawing "48" DIAMOND – CORNER POCKET AND RIB CONFIGURATION". Orders will specify the quantity of each fabrication number to be supplied.

### **ADDITIONAL SPECIFICATIONS FOR BID ITEM 34**

Items supplied as part of Bid Item 34 shall be standard message (as shown in the WVDOH Sign Fabrication Details) orange and black 48"x48" diamond shaped construction zone warning signs, with the addition of 2 to 4 ea. 28" long x 1/2" wide orange velcro strips to be glued or sewn onto the sign face, and 2 ea. 18" x 18" non-reflective fluorescent orange vinyl flags, as specified above. The velcro strips shall be installed horizontally and parallel to one another, with the measured distance between the outside edges of the strips to be 8". The mid-point along (14") and between (4") the strips shall be centered vertically and horizontally about the portion of text in the sign specified. The text portions of the signs shall be black, and the background portions shall be orange. Rib sizes, rib locations, rib lengths, corner pocket locations, rotation point location, and anti-kite velcro strip locations shall be in substantial conformance as shown in the attached drawing "48" DIAMOND – CORNER POCKET AND RIB CONFIGURATION". Orders will specify the quantity of each fabrication number to be supplied.

### **ADDITIONAL SPECIFICATIONS FOR BID ITEM 35**

Items supplied as part of Bid Item 35 shall be standard message (as shown in the WVDOH Sign Fabrication Details) orange and black 36"x36" diamond shaped construction zone warning signs, with the addition of 2 to 4 ea. 21" long x 1/2" wide orange velcro strips to be glued or sewn onto the sign face. The velcro strips shall be installed horizontally and parallel to one another, with the measured distance between the outside edges of the strips to be 6". The mid-point along (10-1/2") and between (3") the strips shall be centered vertically and horizontally about the portion of text in the sign specified. The text portions of the signs shall be black, and the background portions shall be orange. Rib sizes, rib locations, rib lengths, corner pocket locations, rotation point location, and anti-kite velcro strip locations shall be in substantial conformance as shown in the attached drawing "36" DIAMOND – CORNER POCKET AND RIB CONFIGURATION". Orders will specify the quantity of each fabrication number to be supplied.

**ADDITIONAL SPECIFICATIONS FOR BID ITEM 36**

Items supplied as part of Bid Item 36 shall be standard message (as shown in the WVDOH Sign Fabrication Details) orange and black 36"x36" diamond shaped construction zone warning signs, with the addition of 2 to 4 ea. 21" long x 1/2" wide orange velcro strips to be glued or sewn onto the sign face, and 2 ea. 18" x 18" non-reflective fluorescent orange vinyl flags, as specified above. The velcro strips shall be installed horizontally and parallel to one another, with the measured distance between the outside edges of the strips to be 6". The mid-point along (10-1/2") and between (3") the strips shall be centered vertically and horizontally about the portion of text in the sign specified. The text portions of the signs shall be black, and the background portions shall be orange. Rib sizes, rib locations, rib lengths, corner pocket locations, rotation point location, and anti-kite velcro strip locations shall be in substantial conformance as shown in the attached drawing "36" DIAMOND - CORNER POCKET AND RIB CONFIGURATION". Orders will specify the quantity of each fabrication number to be supplied.

**ADDITIONAL SPECIFICATIONS FOR BID ITEM 37**

Items supplied as part of Bid Item 37 shall be individual message plaques intended to be attached to the face of signs supplied under Bid Items 33 and 34. The text portions of the plaques shall be black, and the background portions shall be orange. The overall size of each individual plaque shall be 8" tall x 28" wide. Text shall be 7" Series C. Text shall be centered vertically and horizontally in each plaque. 2 ea. 28" long x 1/2" wide pieces of velcro shall be glued or sewn onto the back face of each plaque, with 1 ea. of the pieces along the top and bottom edges of the plaque, and with the outside edge of each piece along the outside edge of the plaque. Orders will specify the quantity of each individual plaque to be supplied.

**ADDITIONAL SPECIFICATIONS FOR BID ITEM 38**

Items supplied as part of Bid Item 38 shall be individual message plaques intended to be attached to the face of signs supplied under Bid Items 35 and 36. The text portions of the plaques shall be black, and the background portions shall be orange. The overall size of each individual plaque shall be 6" tall x 21" wide. Text shall be 5" Series C. Text shall be centered vertically and horizontally in each plaque. 2 ea. 21" long x 1/2" wide pieces of velcro shall be glued or sewn onto the back face of each plaque, with 1 ea. of the pieces along the top and bottom edges of the plaque, and with the outside edge of each piece along the outside edge of the plaque. Orders will specify the quantity of each individual plaque to be supplied.

**LOW BIDDER SAMPLE SIGN SUBMITTAL**

As part of the review of bids for this Contract, the Division may, at its' discretion, require bidders being considered for award as part of the sign portion of the Contract to submit sample signs for review. If required, the bidder will be required to submit one or more of the following signs:

- 1 ea. Item # 3
- 1 ea. Item # 11
- 2 ea. Item #12 (1 ea. "4", 1 ea. "5")
- 1 ea. Item # 34, Fab # W20-5A, velcro positioned to allow "RIGHT" and "1500 FT" to be covered.
- 2 ea. Item # 37 (1 ea. "LEFT", 1 ea. "500 FT")

The bidder will be required to submit the signs requested within 1-week of notification. Failure to supply the requested signs within this time frame may result in the disqualification of the vendor's bid. Samples are to be delivered to the following address:

WVDOH-Traffic Engineering Division  
Traffic Services Complex  
180 Dry Branch Rd.  
Charleston, WV 25306  
ATTN: Ted Whitmore

**DELIVERY**

All materials shall be delivered within forty-five (45) days ARO. Late delivery charges against the vendor may be assessed at a rate of \$120.00 per calendar day after forty-five (45) days ARO.

### **PURCHASE HISTORY REPORTS**

As part of this Contract, the vendor shall be required to submit semi-annual purchase history reports to the WVDOH. The vendor should submit this report in a summarized spreadsheet format. The spreadsheet columns should be labeled in general conformance to the following:

**PO NUMBER** (*Use VISA doc. number if purchased on P-card*)

**PURCHASE METHOD** (*Indicate "Blanket Release Order" or "P-card"*)

**QTY. LINE ITEM 1 ORDERED**

**QTY. LINE ITEM 2 ORDERED**

.

.

**QTY LINE ITEM "N" ORDERED** (*N = number of line items on Contract*)

**SHIPPING DESTINATION** (*Indicate the city or town the order was shipped to*)

**TOTAL VALUE OF ORDER**

Each report shall include summary totals of the quantity of each line item ordered and the total value of all orders placed for both the period that the report covers and from the original effective date of the Contract. After award of the Contract, the first report the Vendor will be required to submit shall be for the first 180 days of the Contract, beginning at the original effective date of the Contract. The next report shall be for the period between the end of the period covered by the first report and the expiration date of the Contract, or the effective renewal date of the Contract. Reports shall continue to be submitted as described above for the life of the Contract. The due date for submission of reports shall be 15 days after the last day of the period covered by the report. Preferably, the Vendor should submit all reports in Microsoft Excel format to Ted Whitmore's attention at e-mail address [twhitmore@dot.state.wv.us](mailto:twhitmore@dot.state.wv.us). The Vendor may also submit reports to Ted Whitmore's attention at the following address:

**WVDOH-Traffic Engineering Division**

**Bldg. 5 – Rm. A550**

**1900 Kanawha Blvd. East**

**Charleston, WV 25305**

The Vendors reports shall include all purchases made, regardless of method of order placement (phone, fax, mail, internet). Failure to submit the above described reports may be grounds for cancellation of this Contract, and/or may result in a Vendor Complaint being registered with the State Purchasing Division.

### **MINIMUM ORDERS**

There shall be no minimum order requirement for this contract.



**NOTE:** Vendor should type price on Bid Schedule

**BID SCHEDULE**

The following estimated quantities are for bid purposes only. Actual quantities will be determined by needs of the West Virginia Division of Highways and may be increased or decreased.

ITEM NUMBER	ESTIMATED QUANTITY	DESCRIPTION	INVENTORY SUBCODE (DOH USE)	UNIT PRICE	TOTAL AMOUNT
<b>STAND PORTION</b>					
1	800	Ea., Compact, Portable Sign Stand		NO BID	
MANUFACTURER AND MODEL BID: _____					
2	80	Ea., Large, Aluminum Substrate Sign and Oversized Roll-Up Sign Portable Sign Stand		NO BID	
MANUFACTURER AND MODEL BID: _____					
<b>SIGN PORTION</b>					
MANUFACTURER'S SIGN BID: <u>TRAFFIC DEVICES</u>					
3	10	EA, 36" R1-1F "STOP" sign	010107	\$88.08	\$880.80
4	10	EA, 48" R1-1F "STOP" sign	010108	\$133.57	\$1,335.70
5	10	EA, 36" W3-1MF SYMBOLIC "STOP AHEAD" sign		\$94.94	\$949.40
6	10	EA, 48" W3-1MF SYMBOLIC "STOP AHEAD" sign		\$149.09	\$1,490.90
7	10	EA, 36" R1-2F "YIELD" sign		\$94.94	\$949.40
8	10	EA, 48" R1-2F "YIELD" sign		\$123.07	\$1,230.70
9	10	EA, 36" W3-2MF SYMBOLIC "YIELD AHEAD" sign		\$91.90	\$919.00
10	10	EA, 48" W3-2MF SYMBOLIC "YIELD AHEAD" sign		\$146.48	\$1,464.80

ITEM NUMBER	ESTIMATED QUANTITY	DESCRIPTION	INVENTORY SUBCODE (DOH USE)	UNIT PRICE	TOTAL AMOUNT
11	10	EA., 36" x 60" R2-1MF "WORK ZONE SPEED LIMIT _____" W/ VELCRO FOR NUMERAL OVERLAY PLAQUES (ORDER NUMERALS BELOW)	010289	\$155.09	\$1550.90
12	10	EA., 14" X 17" NUMERAL OVERLAY PLAQUES FOR ITEM NUMBER 11 (SPECIFY QTY OF EACH INDIVIDUAL NUMERAL TO BE SUPPLIED)		\$16.75	167.50
13	10	EA., 48" X 24" R4-14(L/R)F "ALL TRAFFIC (W/ INTERCHANGEABLE ARROW HEAD)"		\$90.63	906.30
14	10	EA, 24"x30" R4-7BF "KEEP RIGHT" SIGN (WITH ARROW)		\$57.43	574.30
15	10	EA, 36"x48" R4-7BF "KEEP RIGHT" SIGN (WITH ARROW)		\$105.62	1,056.20
16	10	EA., 30"x18" R9-9F "SIDEWALK CLOSED"		\$48.39	483.90
17	10	EA., 48"x30" R11-2F "ROAD CLOSED" W/ VELCRO FOR OVERLAY PLAQUES (ORDER "BRIDGE" AND "RAMP" OVERLAYS BELOW)	011110	\$93.95	939.50
18	10	EA., 10" X 39" "BRIDGE" AND "RAMP" OVERLAY PLAQUES FOR ITEM 17 (SPECIFY QTY OF EACH INDIVIDUAL PLAQUE TO BE SUPPLIED)		\$24.44	244.40
19	10	EA., 60" X 30" R11-3AF "ROAD CLOSED _____ MI AHEAD LOCAL TRAFFIC ONLY" W/ VELCRO FOR NUMERAL OVERLAY PLAQUES (ORDER NUMERALS BELOW)	011128	\$111.15	1,111.50
20	10	EA., 5" X 7" NUMERAL OVERLAY PLAQUES FOR ITEM NUMBER 19 (SPECIFY QTY OF EACH INDIVIDUAL NUMERAL TO BE SUPPLIED)		\$18.30	183.00
21	10	EA., 60"x30" R11-4F "ROAD CLOSED TO THRU TRAFFIC"	011135	\$111.72	1,117.20
22	10	EA., 48"x36" W22-10F "EXIT _____" W/ VELCRO FOR OVERLAYS (ORDER "OPEN" AND "CLOSED" PLAQUES BELOW)	022260	\$105.94	1,059.40
23	10	EA., 10" X 26-1/2" "OPEN" AND "CLOSED" OVERLAY PLAQUES FOR ITEM 22 (SPECIFY QTY OF EACH INDIVIDUAL PLAQUE TO BE SUPPLIED)		\$19.25	192.50
24	10	EA., 60"x60" W22-11F EXIT GORE SIGN (NOTE: THIS SIGN TO BE INSTALLED ONLY WITH THE STAND PROVIDED UNDER BID ITEM #2)	022269	\$195.75	1,957.50
25	10	EA., 30"x24" M4-9F STANDARD DETOUR SIGN W/ VELCRO AND ARROW OVERLAY PLAQUE		\$71.05	710.50

ITEM NUMBER	ESTIMATED QUANTITY	DESCRIPTION	INVENTORY SUBCODE (DOH USE)	UNIT PRICE	TOTAL AMOUNT
26	10	EA., 48"X48" EMERGENCY RESPONSE TRAILER DETOUR SIGN W/ VELCRO FOR OVERLAY PLAQUES AND ARROW OVERLAY PLAQUE (ORDER ROUTE AND CARDINAL DIRECTION PLAQUES BELOW)	114848	\$149.60	1,496.00
27	10	EA., 9" X 28" EMERGENCY RESPONSE TRAILER ROUTE OVERLAY PLAQUE FOR ITEM 26 (SPECIFY EACH INDIVIDUAL ROUTE PLAQUE TO BE SUPPLIED AND QTY OF EACH)	110928	\$18.50	185.00
28	10	EA., 9" X 7" EMERGENCY RESPONSE TRAILER CARDINAL DIRECTION OVERLAY PLAQUE FOR ITEM 26 (SPECIFY QTY OF EACH "N", "S", "E", AND "W" PLAQUES TO BE SUPPLIED)	110709	\$10.82	108.20
29	330	Ea., 48" x 48" diamond, fluorescent orange, standard message roll-up sign (SPECIFY QUANTITY OF EACH FABRICATION NUMBER TO BE SUPPLIED)		\$117.84	38,887.20
30	400	Ea., 48" x 48" diamond, fluorescent orange, standard message roll-up sign, with permanent addition of two (2) 18" x 18" vinyl folding flags. (SPECIFY QUANTITY OF EACH FABRICATION NUMBER TO BE SUPPLIED)		\$126.90	50,760.00
31	240	Ea., 36" x 36" diamond, fluorescent orange, standard message roll-up sign (SPECIFY QUANTITY OF EACH FABRICATION NUMBER TO BE SUPPLIED)		\$75.90	18,216.00
32	720	Ea., 36" x 36" diamond, fluorescent orange, standard message roll-up sign, with permanent addition of two (2) 18" x 18" vinyl folding flags. (SPECIFY QUANTITY OF EACH FABRICATION NUMBER TO BE SUPPLIED)		\$83.96	60,451.20
33	70	Ea., 48" x 48" diamond, fluorescent orange, standard message roll-up sign, with attached velcro strips to allow for the use of overlays (SPECIFY QTY OF EACH FABRICATION NUMBER TO BE SUPPLIED AND PORTION OF TEXT INTENDED TO BE COVERED WITH OVERLAY PLAQUES - ORDER OVERLAY PLAQUES UNDER BID ITEM 37)		\$126.32	8,842.40
34	70	Ea., 48" x 48" diamond, fluorescent orange, standard message roll-up sign, with permanent addition of two (2) 18" x 18" vinyl folding flags and attached velcro strips to allow for the use of overlays (SPECIFY QTY OF EACH FABRICATION NUMBER TO BE SUPPLIED AND PORTION OF TEXT INTENDED TO BE COVERED WITH OVERLAY PLAQUES - ORDER OVERLAY PLAQUES UNDER BID ITEM 37)		\$135.94	9,515.80
35	100	Ea., 36" x 36" diamond, fluorescent orange, standard message roll-up sign, with attached velcro strips to allow for the use of overlays (SPECIFY QTY OF EACH FABRICATION NUMBER TO BE SUPPLIED AND PORTION OF TEXT INTENDED TO BE COVERED WITH OVERLAY PLAQUES - ORDER OVERLAY PLAQUES UNDER BID ITEM 38)		\$80.67	8,067.00
36	100	Ea., 36" x 36" diamond, fluorescent orange, standard message roll-up sign, with permanent addition of two (2) 18" x 18" vinyl folding flags and attached velcro strips to allow for the use of overlays (SPECIFY QTY OF EACH FABRICATION NUMBER TO BE SUPPLIED AND PORTION OF TEXT INTENDED TO BE COVERED WITH OVERLAY PLAQUES - ORDER OVERLAY PLAQUES UNDER BID ITEM 38)		\$90.29	9,029.00

ITEM NUMBER	ESTIMATED QUANTITY	DESCRIPTION	INVENTORY SUBCODE (DOH USE)	UNIT PRICE	TOTAL AMOUNT
37	150	Ea., 8" x 28" fluorescent orange overlays with attached velcro strips for use with Item Numbers 33 and 34. Examples: LEFT, 500 FT., 1000 FT., 1500 FT., 1/2 MILE, 1 MILE, and AHEAD (SPECIFY QUANTITY OF EACH PLAQUE TO BE SUPPLIED)		\$17.33	2,599.50
38	200	Ea., 6" x 21" fluorescent orange overlays with attached velcro strips for use with Item Numbers 35 and 36. Examples: LEFT, 500 FT., 1000 FT., 1500 FT., 1/2 MILE, 1 MILE, and AHEAD (SPECIFY QUANTITY OF EACH PLAQUE TO BE SUPPLIED)		\$13.12	2,624.00

**NOTES:**

ANY SIGN SPECIFIED WITH TEXT TO BEGIN WITH "ROAD WORK" IS TO BE ORDERED UNDER ITEM NUMBERS 30, 32, 34, AND 36 ONLY. W20-7A AND W21-SIGNS ARE TO BE ORDERED UNDER ITEM NUMBERS 30 OR 32 ONLY

ITEM #24 IS TO BE INSTALLED ONLY ON THE STAND PROVIDED UNDER ITEM #2.

SEE ATTACHED COMMISSIONERS ORDER REGARDING THE PROPER USE OF ITEM # 11

THE STAND SUPPLIED AS PART OF BID ITEM #2 IS NOT TO BE USED WITH ALUM SUBSTRATE SIGNS LARGER THAN 48X48 (DIAMOND), 60X30 (HORIZONTAL RECTANGLE), 36X60 (VERTICAL RECTANGLE), 48" (OCTAGON), 48" (SQUARE), OR 48" (TRIANGLE). CONTACT DT FOR SPECIAL NEED

SAMPLE CORNER POCKET DETAIL DRAWINGS (POCKETS FOR 3/8" X 1-1/4"  
RIB SHOWN)

TWO FASTENER POCKET:

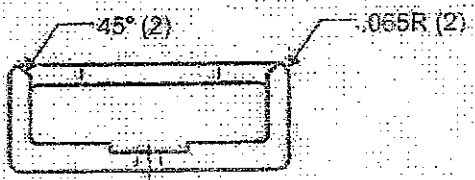
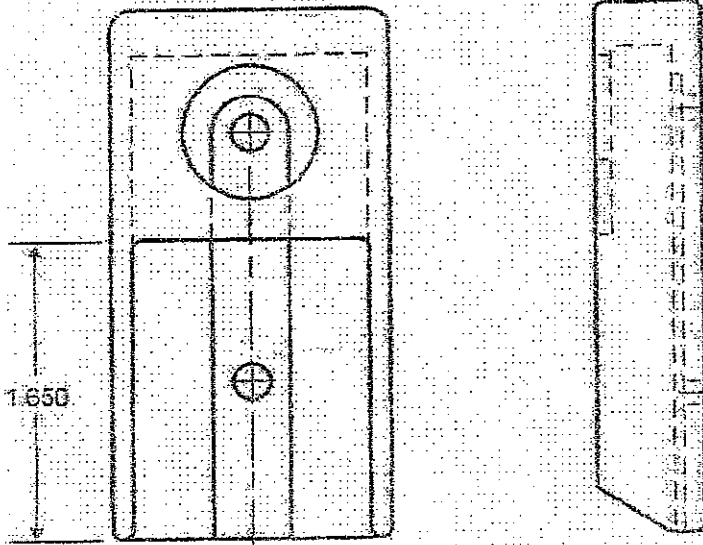

SAMPLE CORNER POCKET DETAIL DRAWINGS - CONTINUED (POCKETS FOR  
3/8" X 1-1/4" RIB SHOWN)

TWO FASTENER POCKET BACK PLATE:

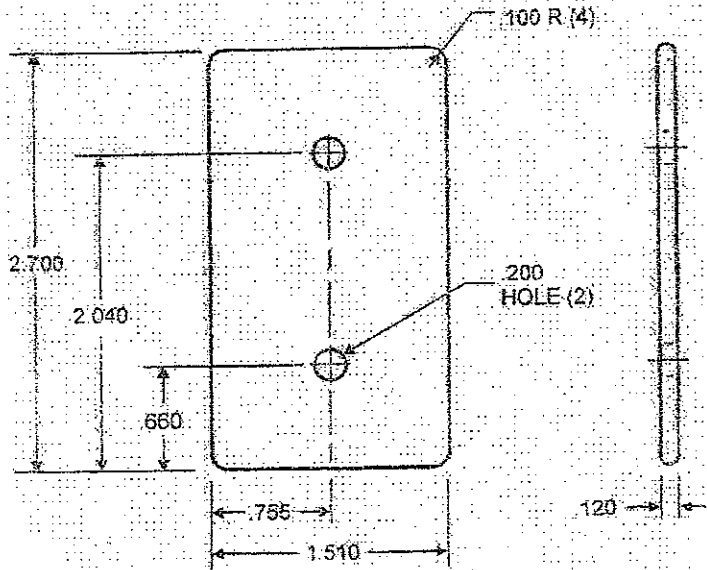

SAMPLE CORNER POCKET DETAIL DRAWINGS - CONTINUED (POCKETS FOR 3/8" X 1-1/4" RIB SHOWN)

THREE FASTENER POCKET:

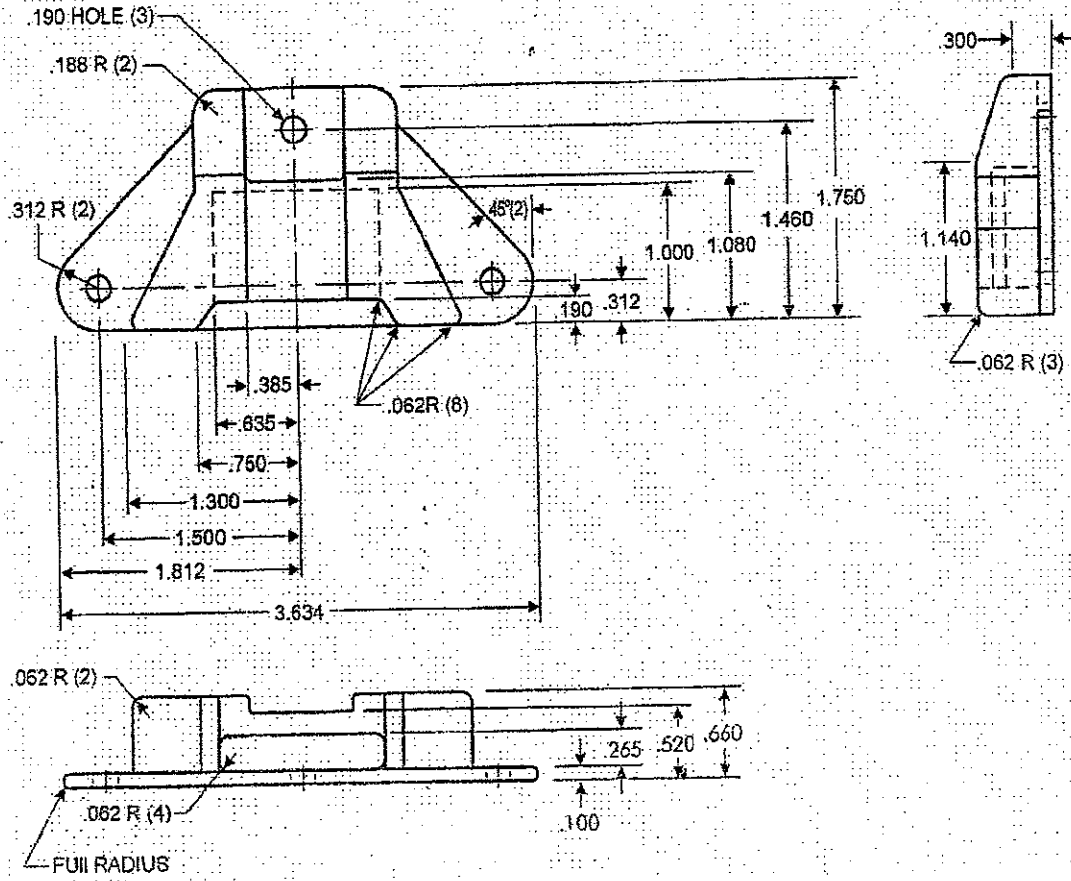

SAMPLE CORNER POCKET DETAIL DRAWINGS - CONTINUED (POCKETS FOR  
3/8" X 1-1/4" RIB SHOWN)

THREE FASTENER POCKET BACK PLATE:

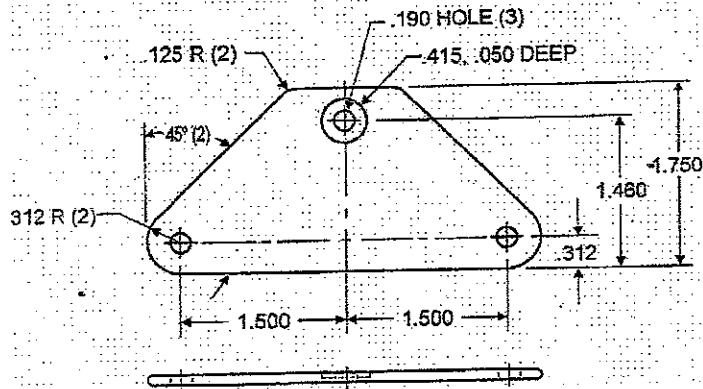



# BID ITEM 11 - MODIFIED STANDARD DETAIL

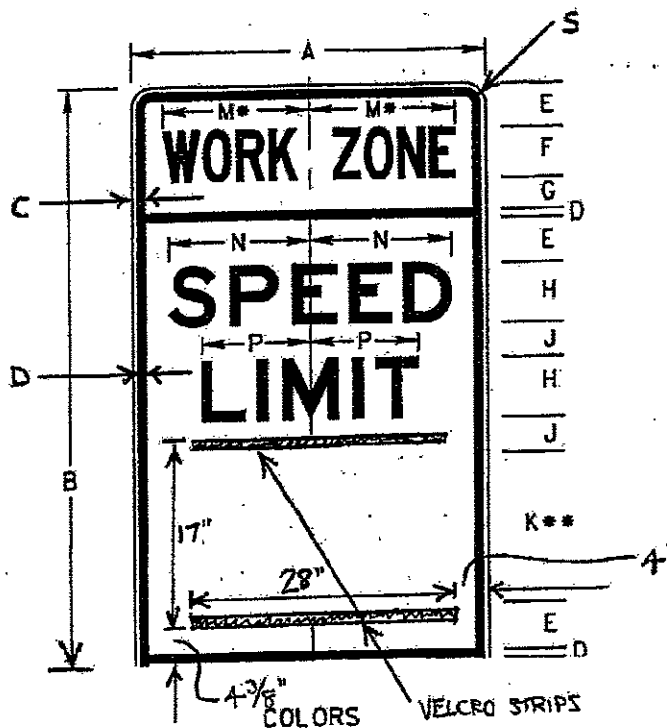

LEGEND - BLACK (NON-REF)  
 TOP BACKGROUND - ORANGE (REF)  
 MIDDLE BACKGROUND - WHITE (REF)

DIMENSIONS (INCHES)

A	B	C	D	E	F	G	H	J	K	M	N	P	S
36	60	5/8	7/8	4 1/2	5C	3 1/8	6E	3 1/2	15E	14 7/8	4 5/16	10 5/16	1 5/8

\* - REDUCE SPACING 50%

# BID ITEM 13 - MODIFIED STANDARD DETAIL

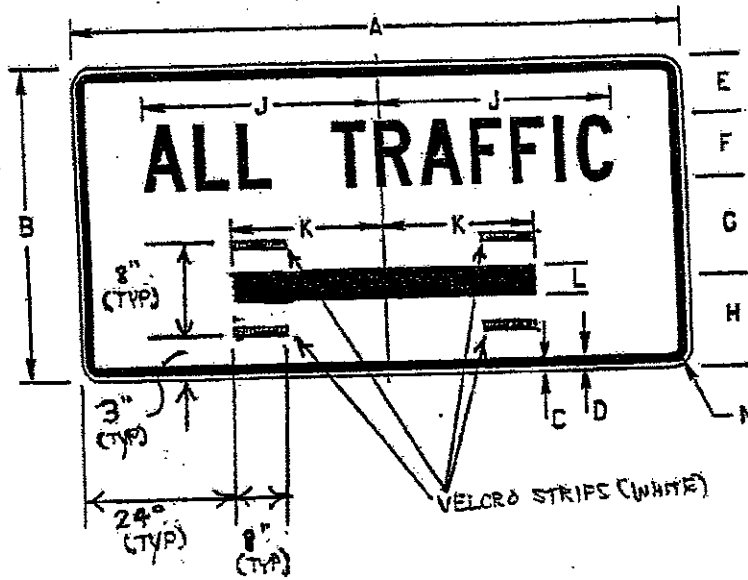

COLOR  
 LEGEND - BLACK (NON-REF)  
 BACKGROUND - WHITE (REF)

DIMENSIONS (INCHES)

A	B	C	D	E	F	G	H	J	K	L	M	N
48	24	3/8	5/8	4 1/2	5C	7 1/2	7	18 1/16	12	2 1/4		1 1/8

## ARROW DETAIL

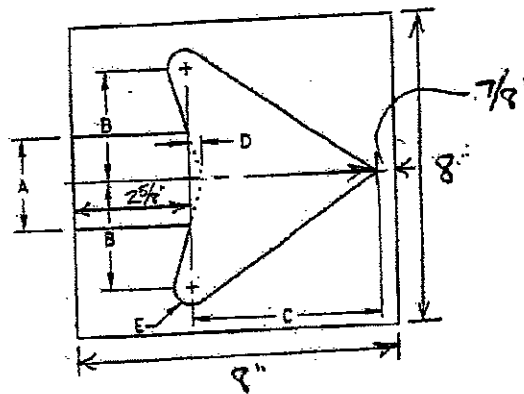

A	B	C	D	E
2 1/4	2 3/8	4 1/2	3/8	1/8

**BID ITEM 17 - MODIFIED STANDARD DETAIL**



**COLORS**  
 LEGEND - BLACK (NON-REF)  
 BACKGROUND - WHITE (REF)

**DIMENSIONS (INCHES)**

A	B	C	D	E	F	G	H	J	K	L
48	30	1/2	3/4	5	8D	4	13 1/4	13 1/2	19	1 3/8

**BID ITEM 19 - MODIFIED STANDARD DETAIL**

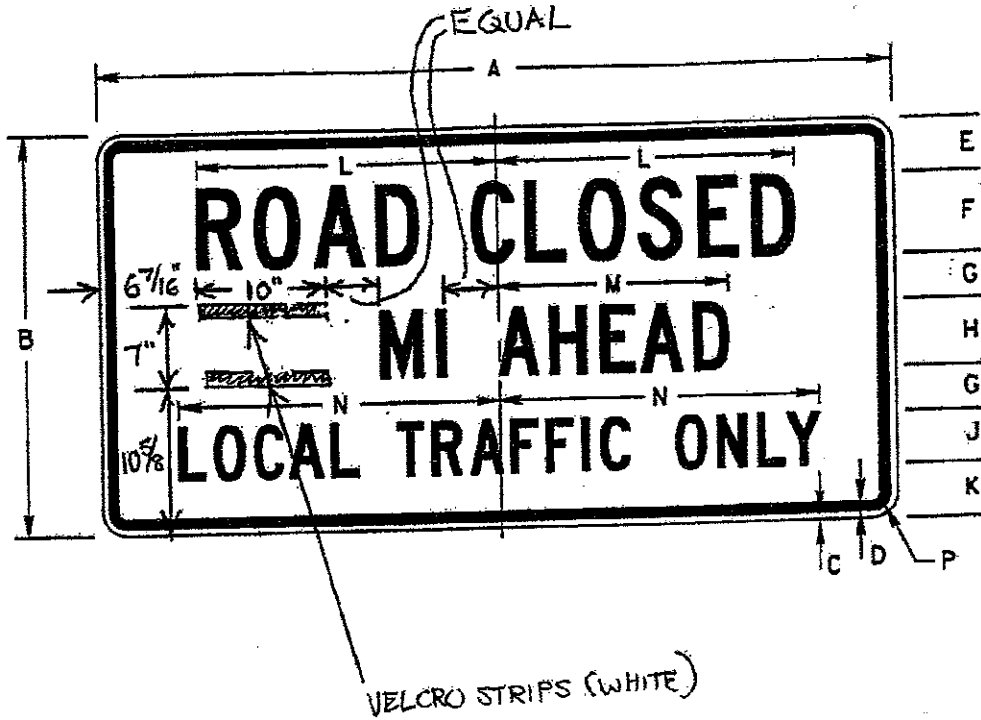

**COLORS**  
 LEGEND - BLACK (NON-REF)  
 BACKGROUND - WHITE (REF)

**DIMENSIONS (INCHES)**

A	B	C	D	E	F	G	H	J	K	L	M	N	P
60	30	1/2	3/4	4	6C	3 3/8	5C	4C	4 1/4	22 3/16	17 3/16	24 5/16	1 3/8

**BID ITEM 22 - MODIFIED STANDARD DETAIL**

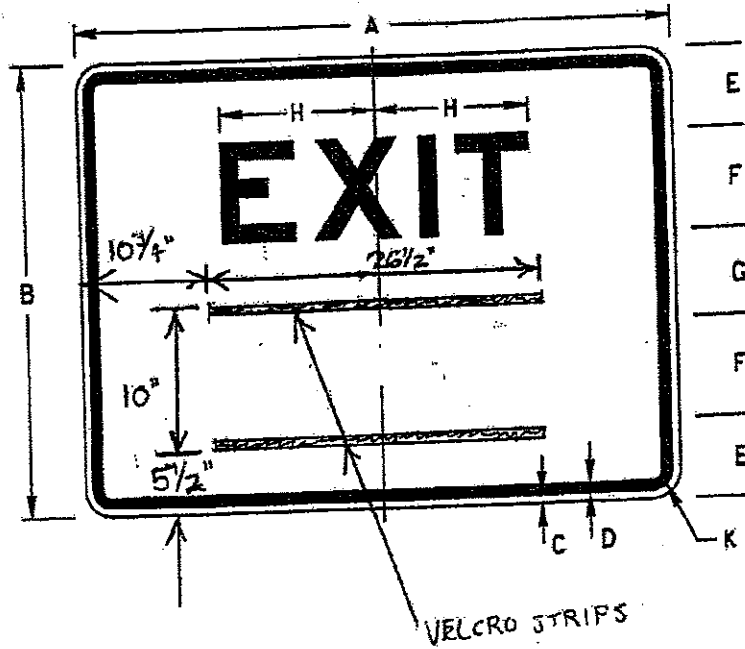

**COLORS**  
**LEGEND - BLACK (NON-REF)**  
**BACKGROUND - ORANGE (REF)**

**DIMENSIONS (INCHES)**

A	B	C	D	E	F	G	H	"	K
4B	36	5/8	3/8	6 1/2	8E	7	12 3/16	:	1 5/8

**BID ITEM 25 - MODIFIED STANDARD DETAIL**

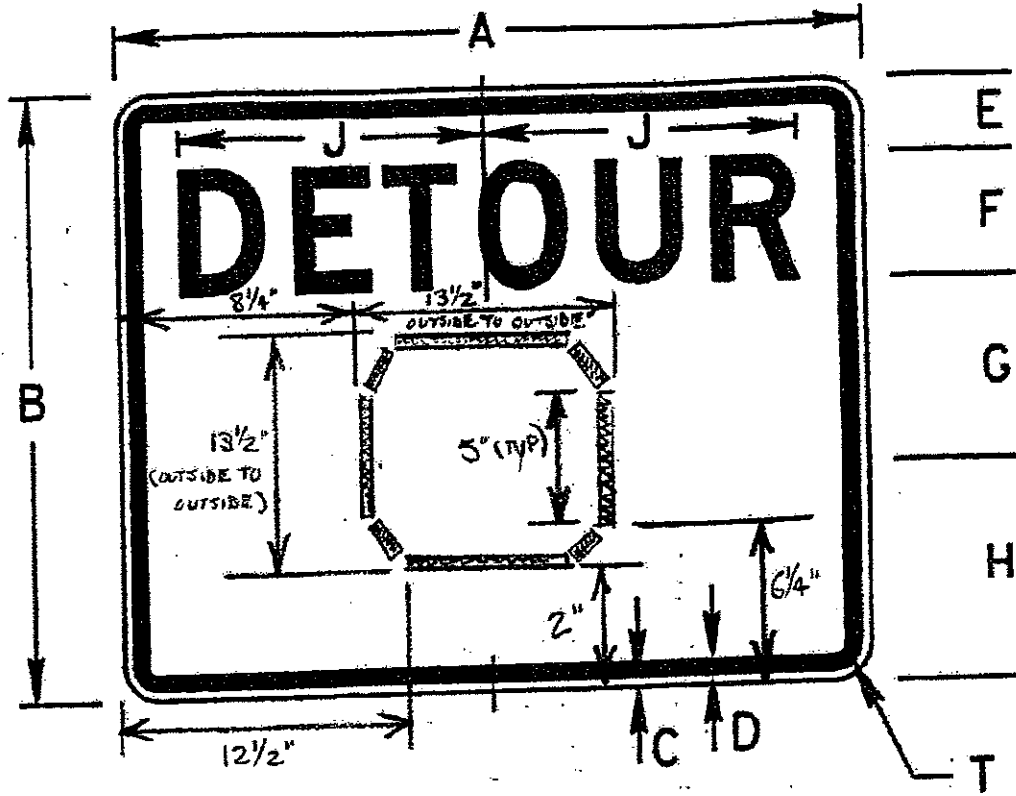

COLORS  
 LEGEND - BLACK (NON-REF)  
 BACKGROUND - ORANGE (REF)  
 DIMENSIONS (INCHES)

A	B	C	D	E	F	G	H	J	M	N	P	O	R	S	T
30	24	3/8	5/8	3	5D	7 1/4	8 3/4	12 1/16	5	1	12 1/2	2 1/2	3	10	1 1/8

**BID ITEM 25 - MODIFIED STANDARD DETAIL (CONTINUED)**

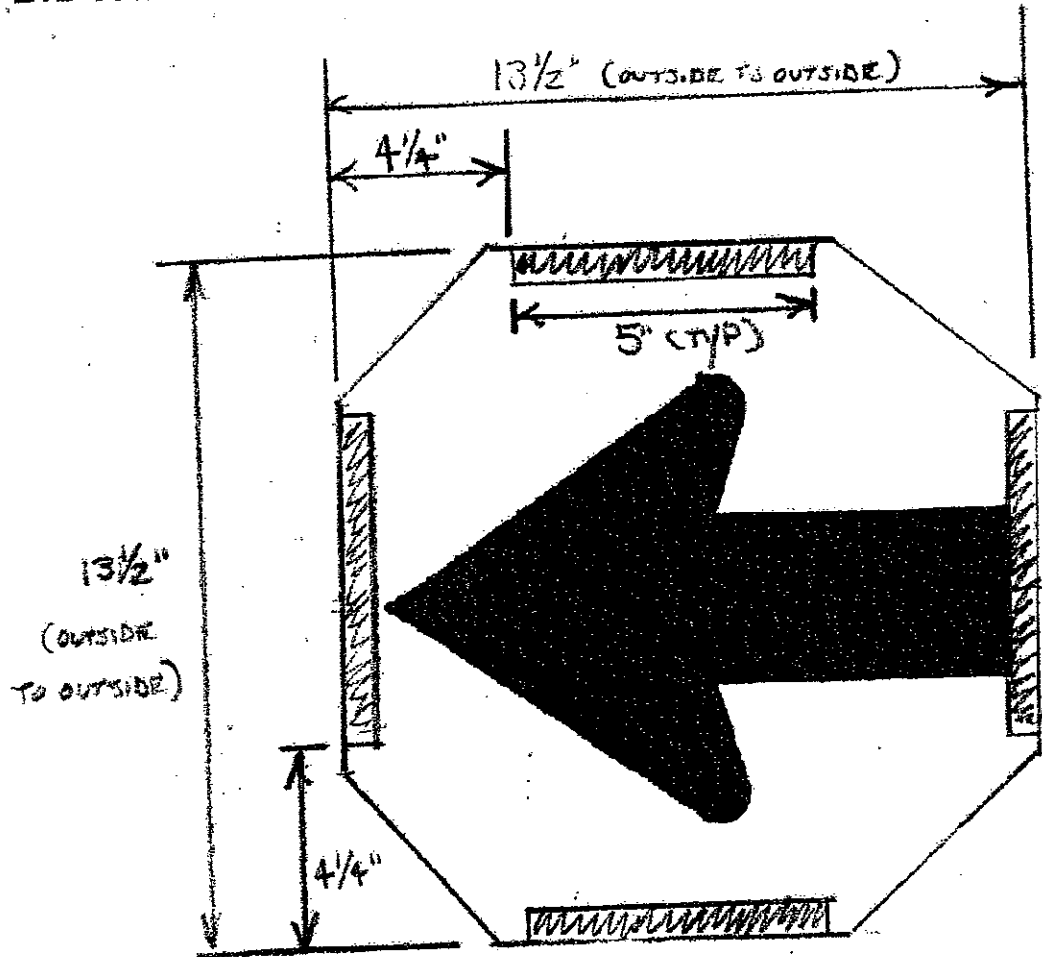

**ARROW DETAIL**

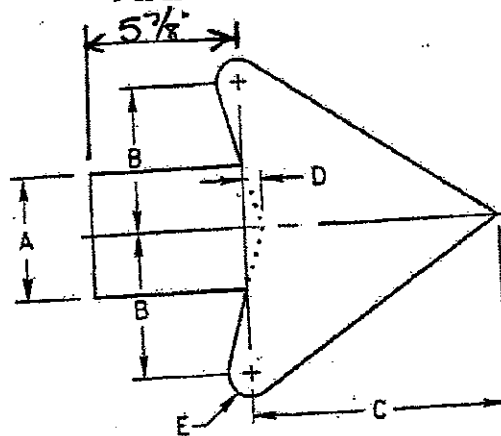

A	B	C	D	E
3/4	3/4	6 5/8	1/2	5/8

# BID ITEM 26 - MODIFIED STANDARD DETAIL

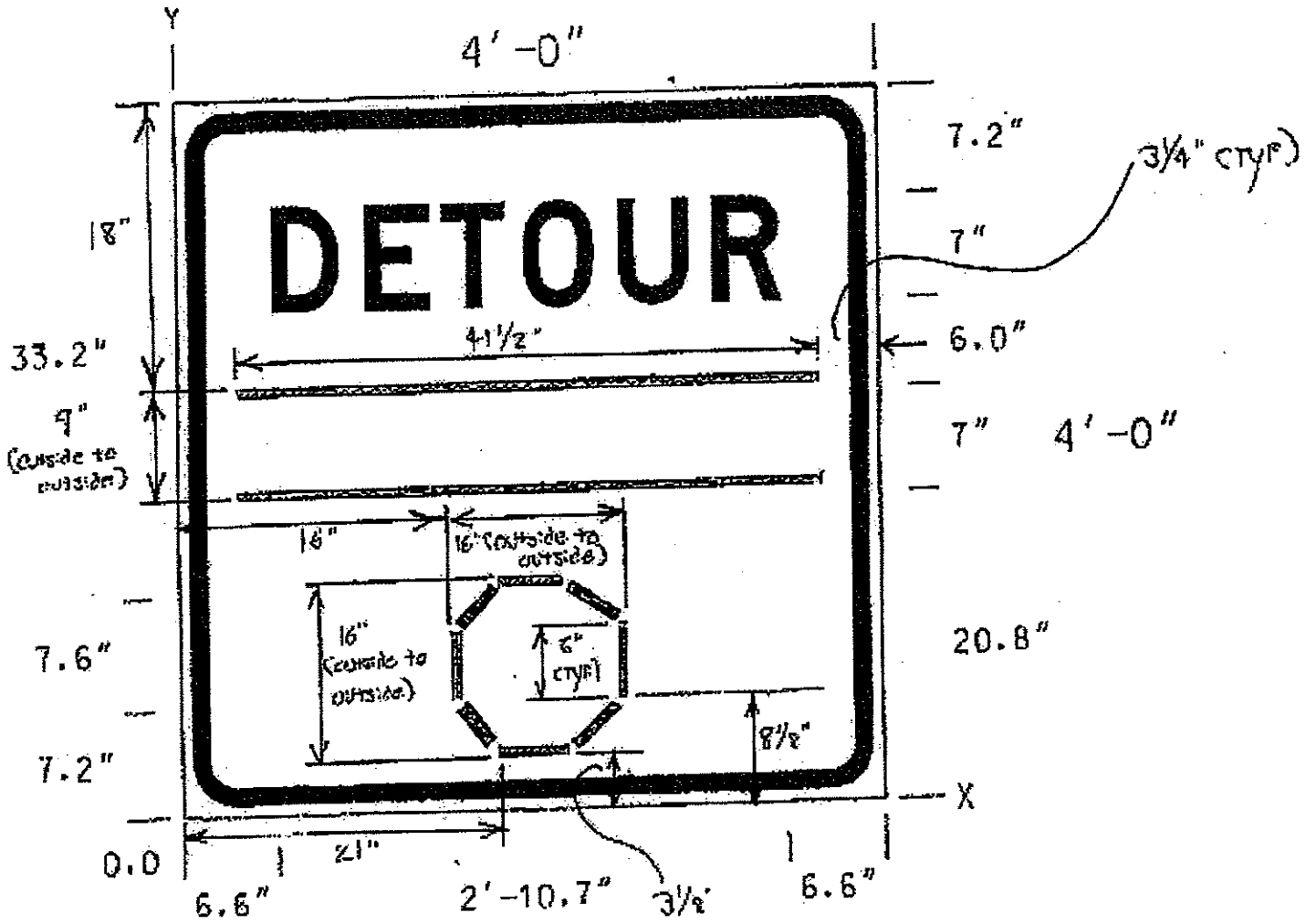



**BID ITEM 26 - MODIFIED STANDARD DETAIL (CONTINUED)**

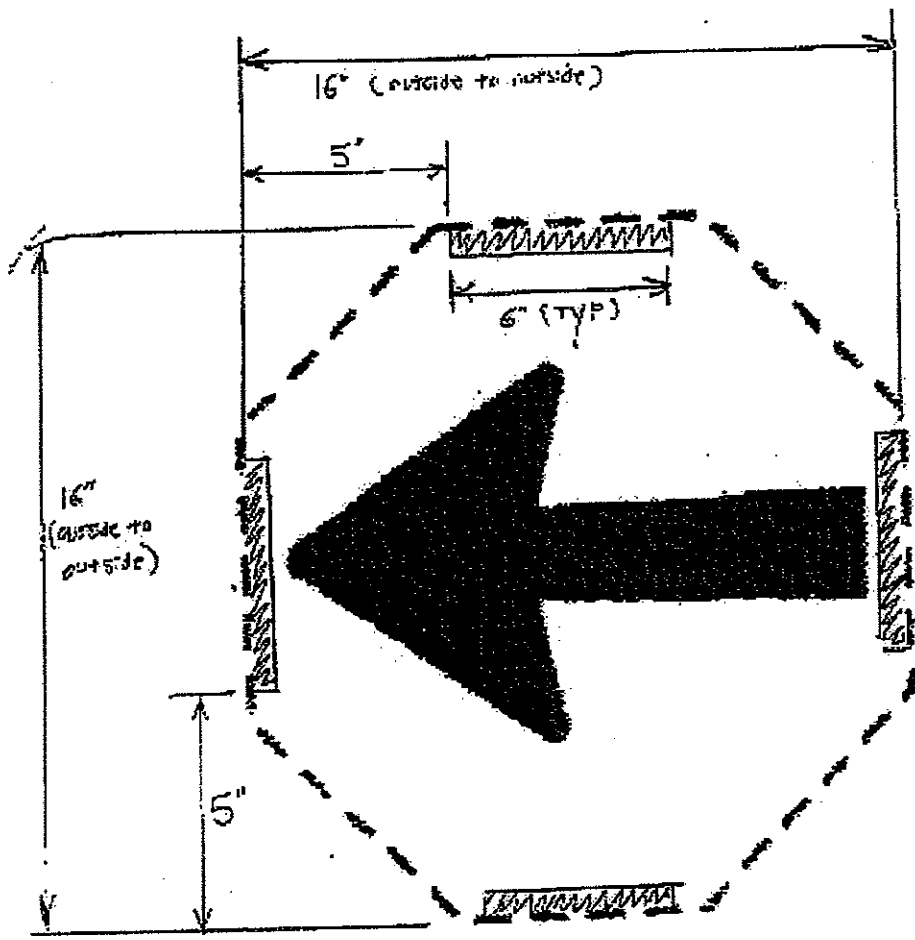

**ARROW DETAIL**

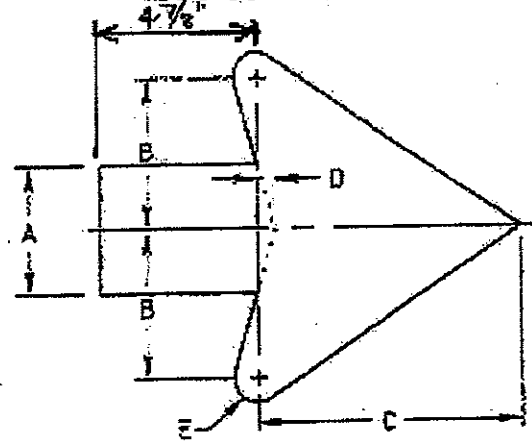

A	B	C	D	E
3 1/2	4	7 1/8	3/16	3/8

# 36" OCTAGON - CORNER POCKET AND RIB CONFIGURATION

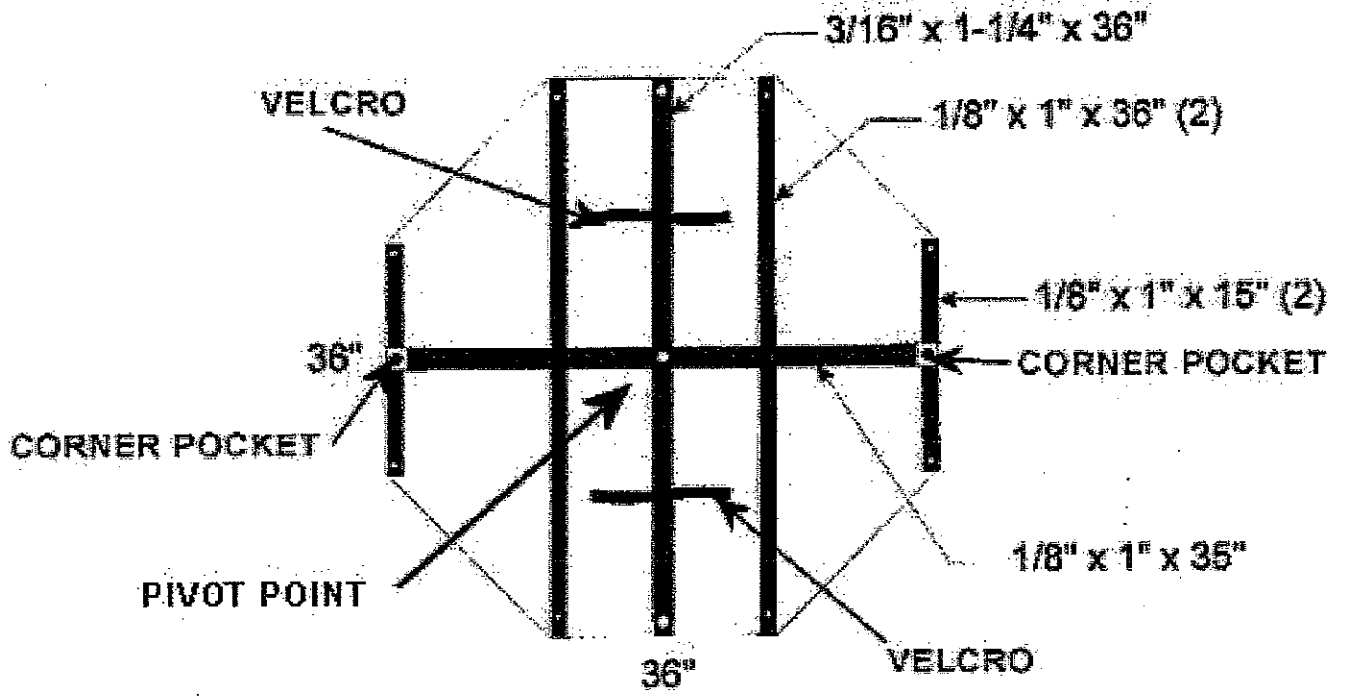

### 48" OCTAGON - CORNER POCKET AND RIB CONFIGURATION

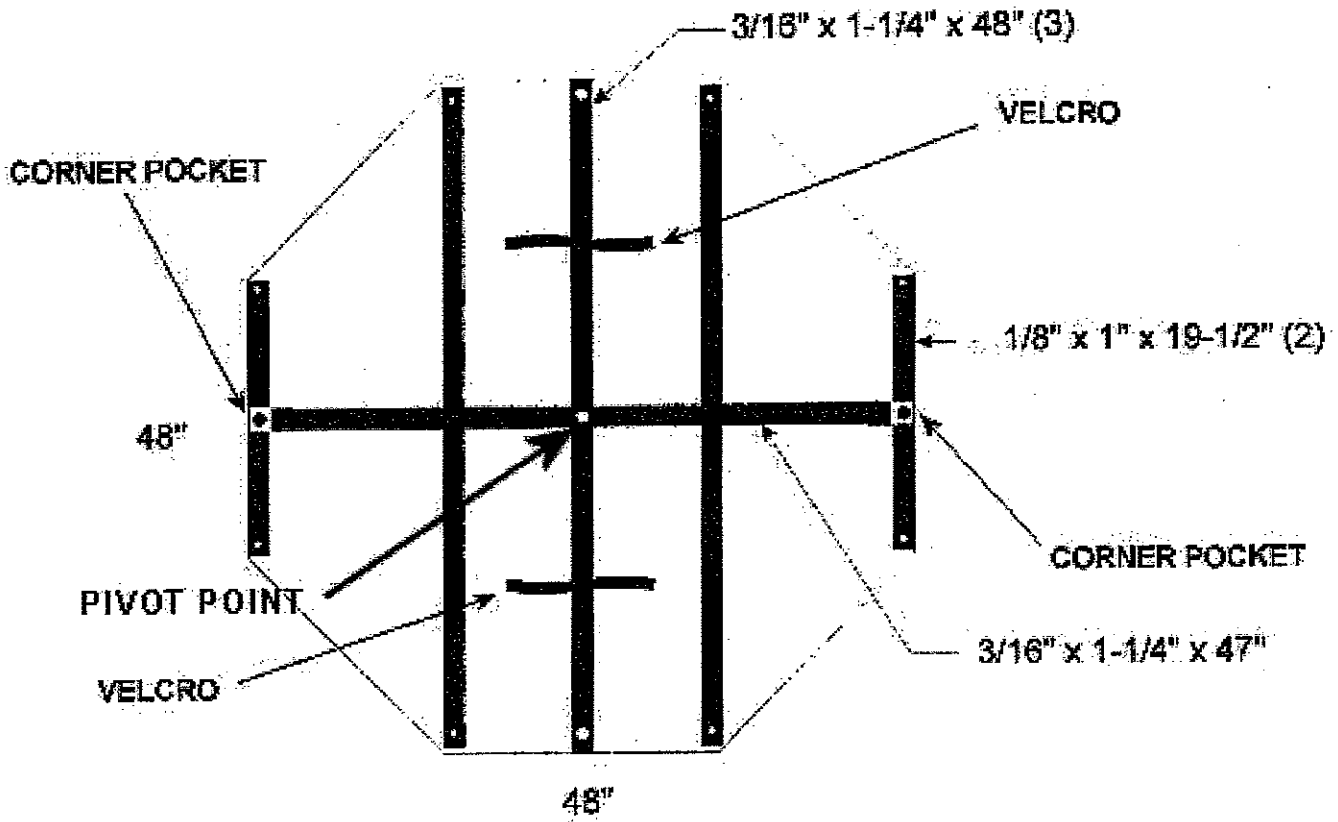

### 36" DIAMOND - CORNER POCKET AND RIB CONFIGURATION

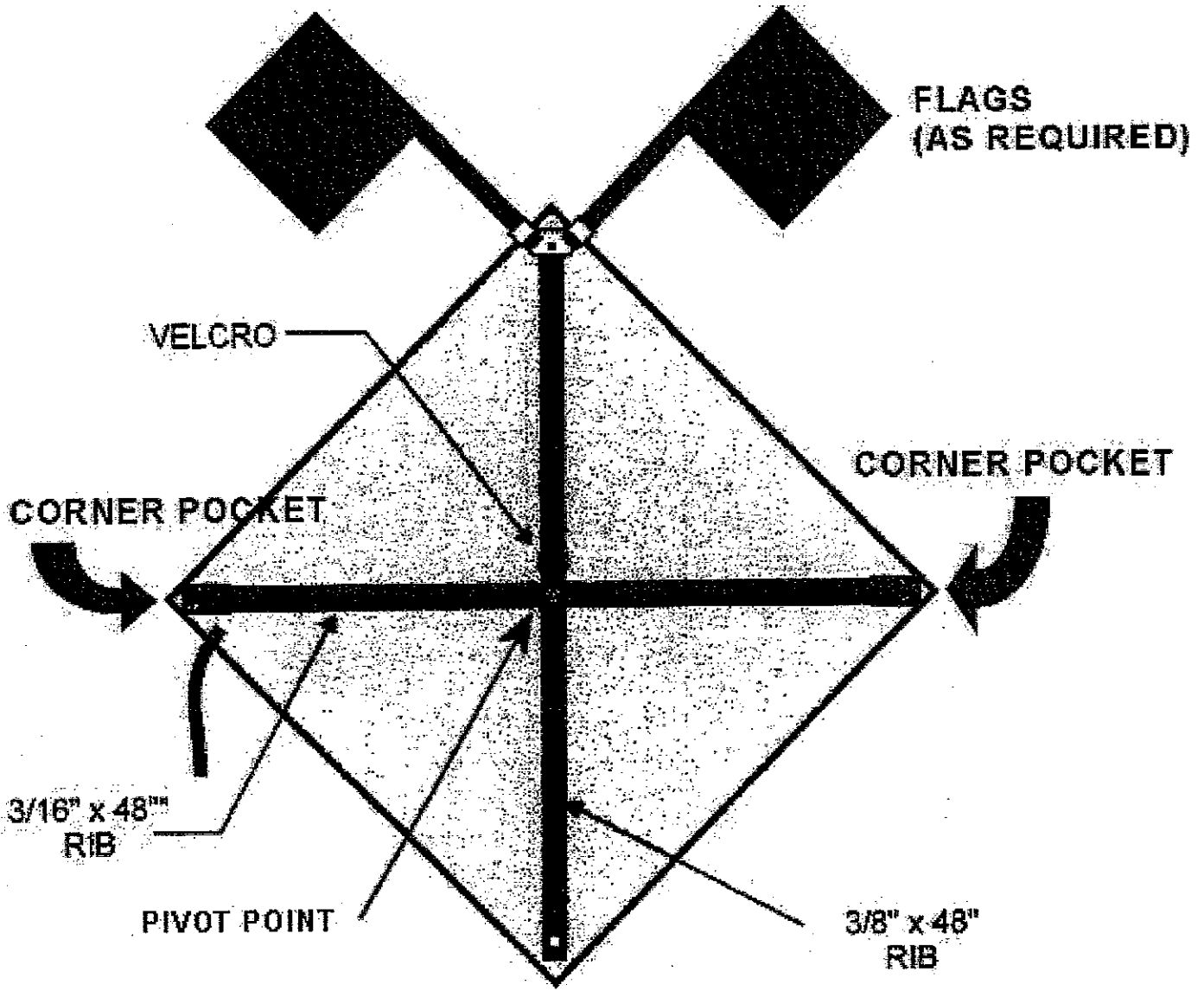

### 48x48 DIAMOND - CORNER POCKET AND RIB CONFIGURATION

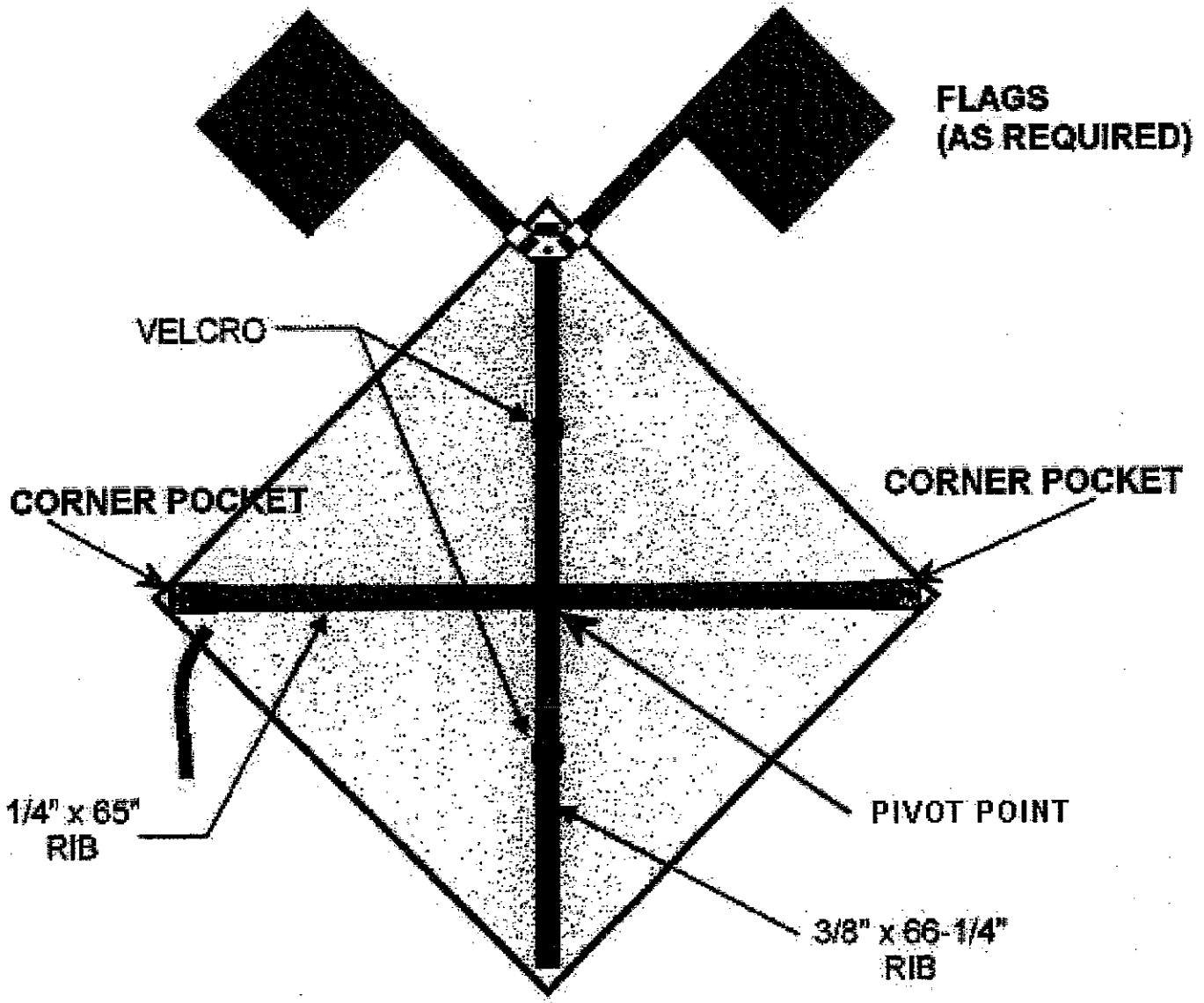

### 36" TRIANGLE - CORNER POCKET AND RIB CONFIGURATION

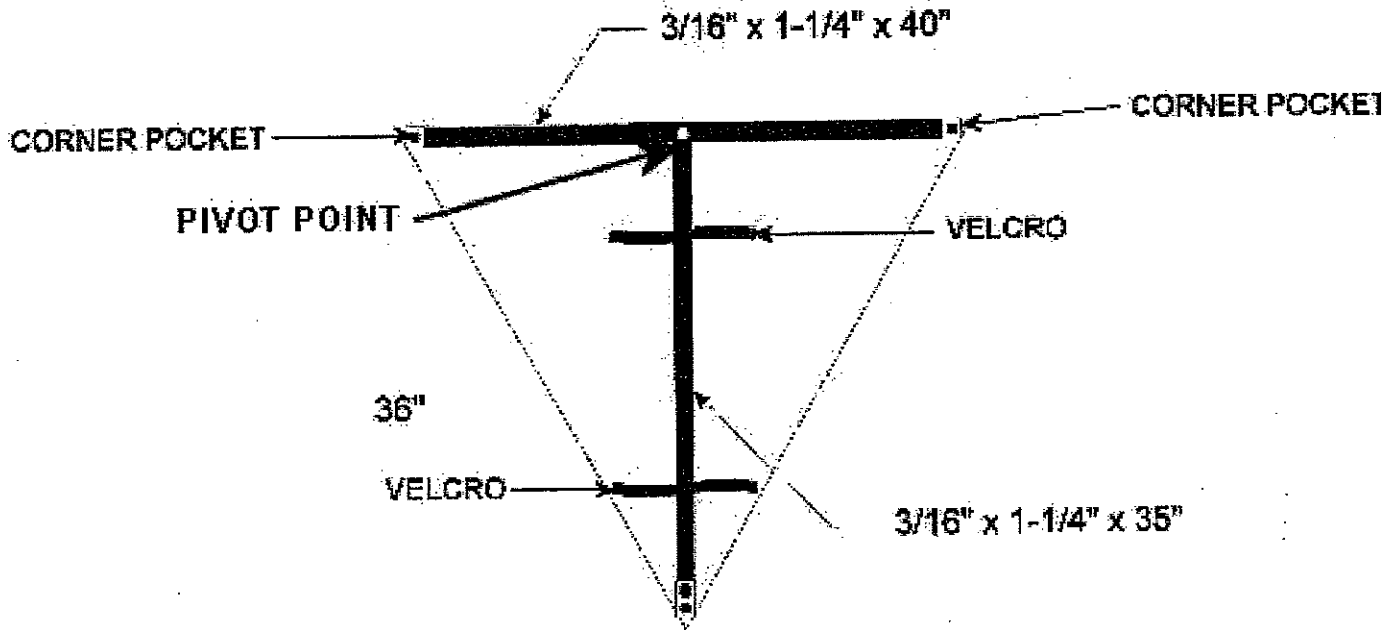

48" TRIANGLE - CORNER POCKET AND RIB CONFIGURATION

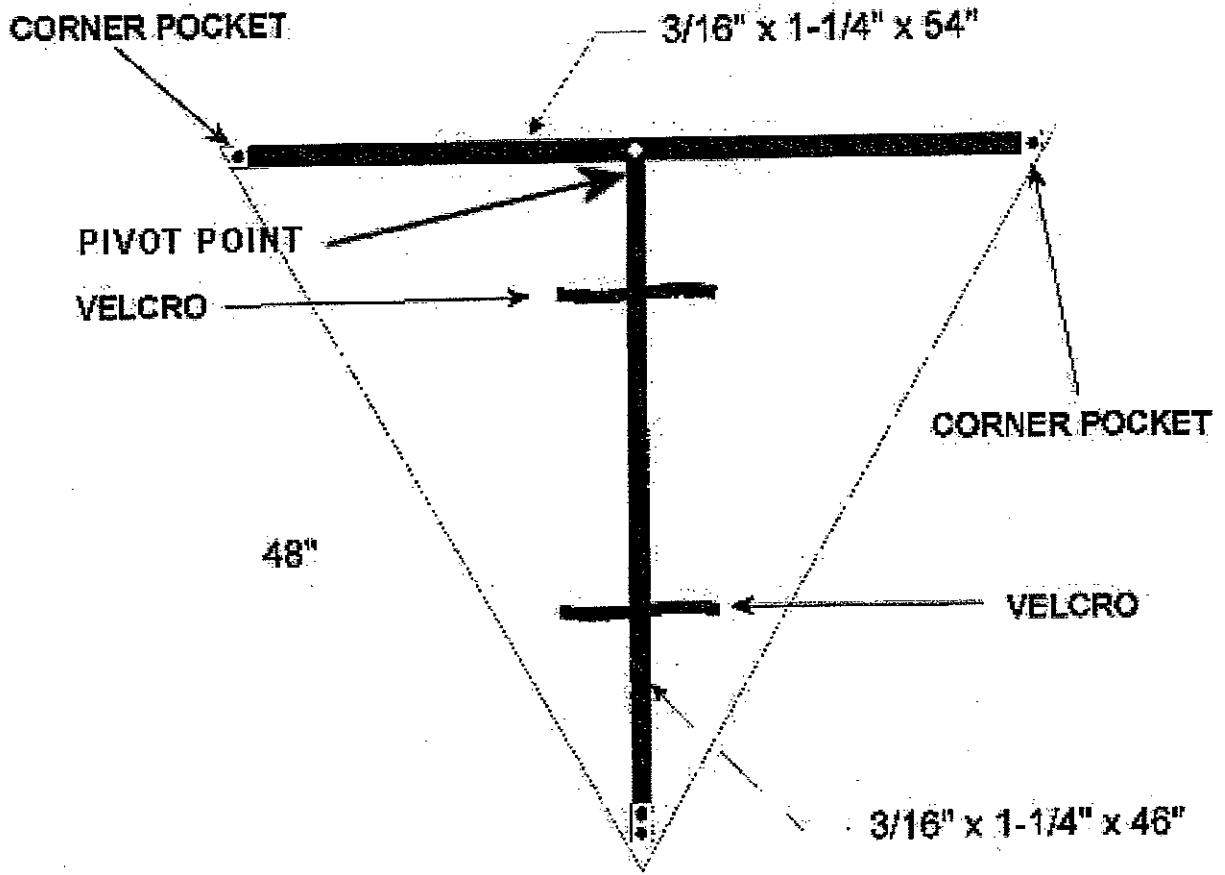

**36x80 VERTICAL RECTANGLE -  
CORNER POCKET AND RIB CONFIGURATION**

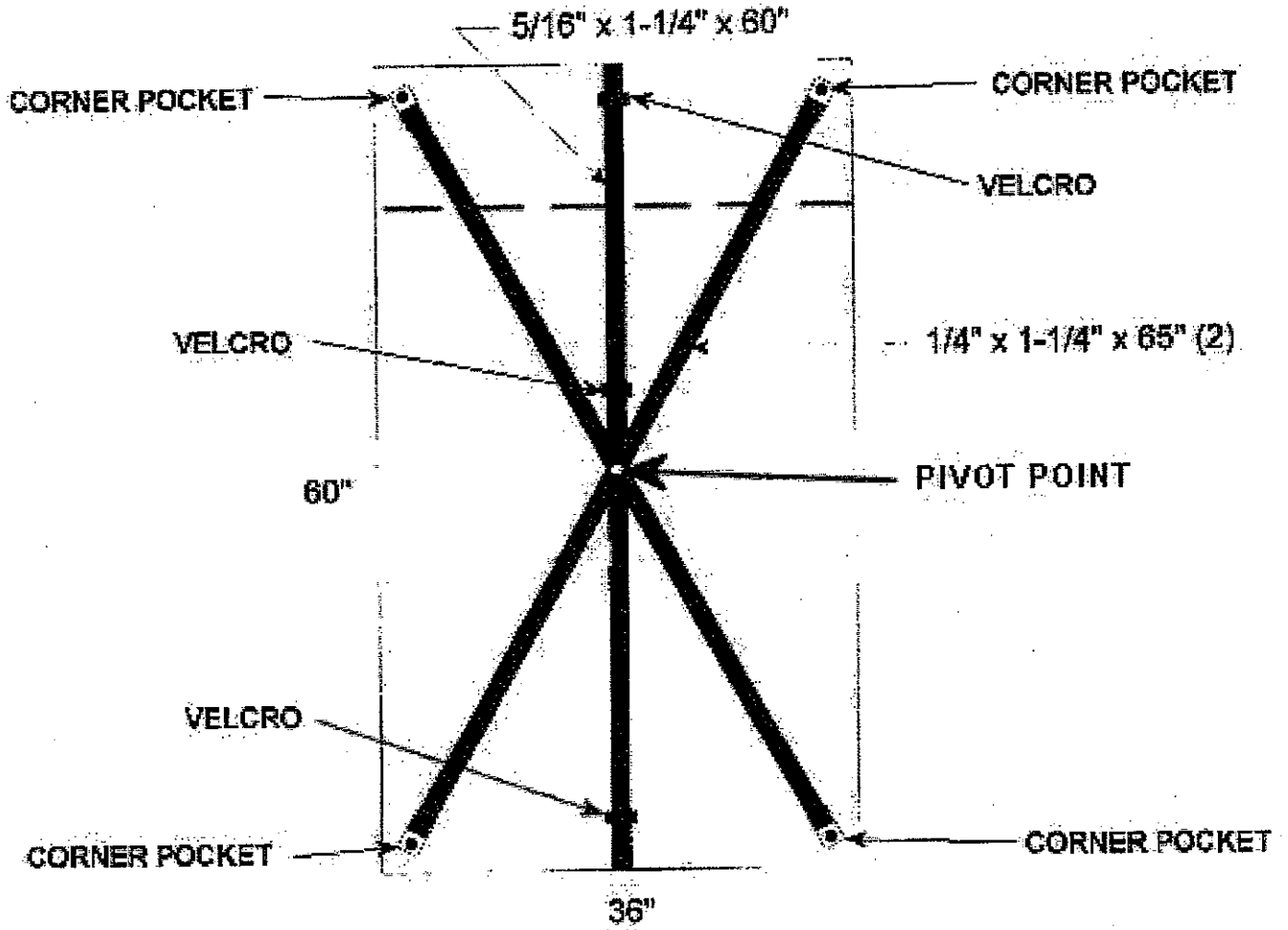



### 48X24 HORIZONTAL RECTANGLE - CORNER POCKET AND RIB CONFIGURATION

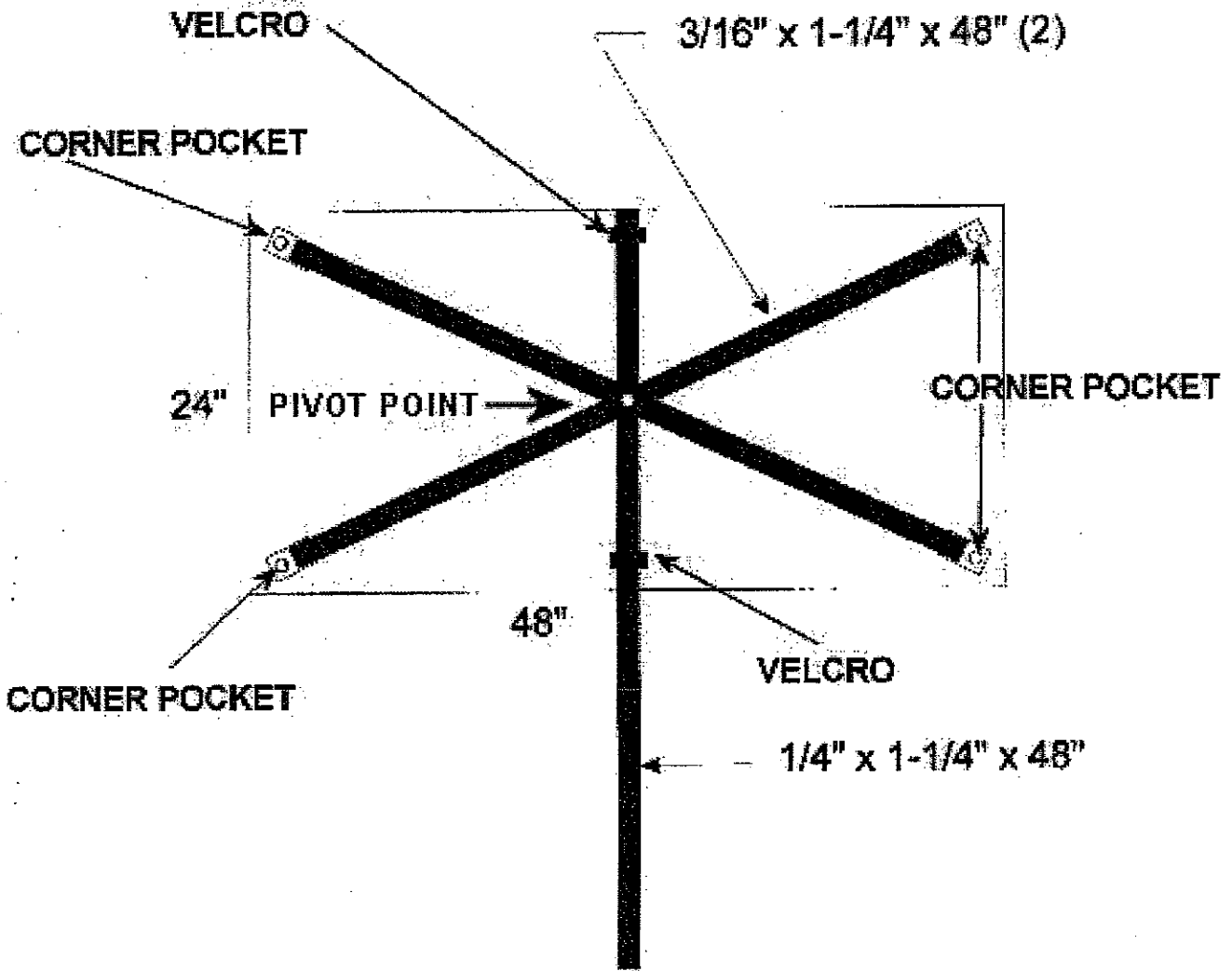

**24 X 30 VERTICAL RECTANGLE -  
CORNER POCKET AND RIB CONFIGURATION**

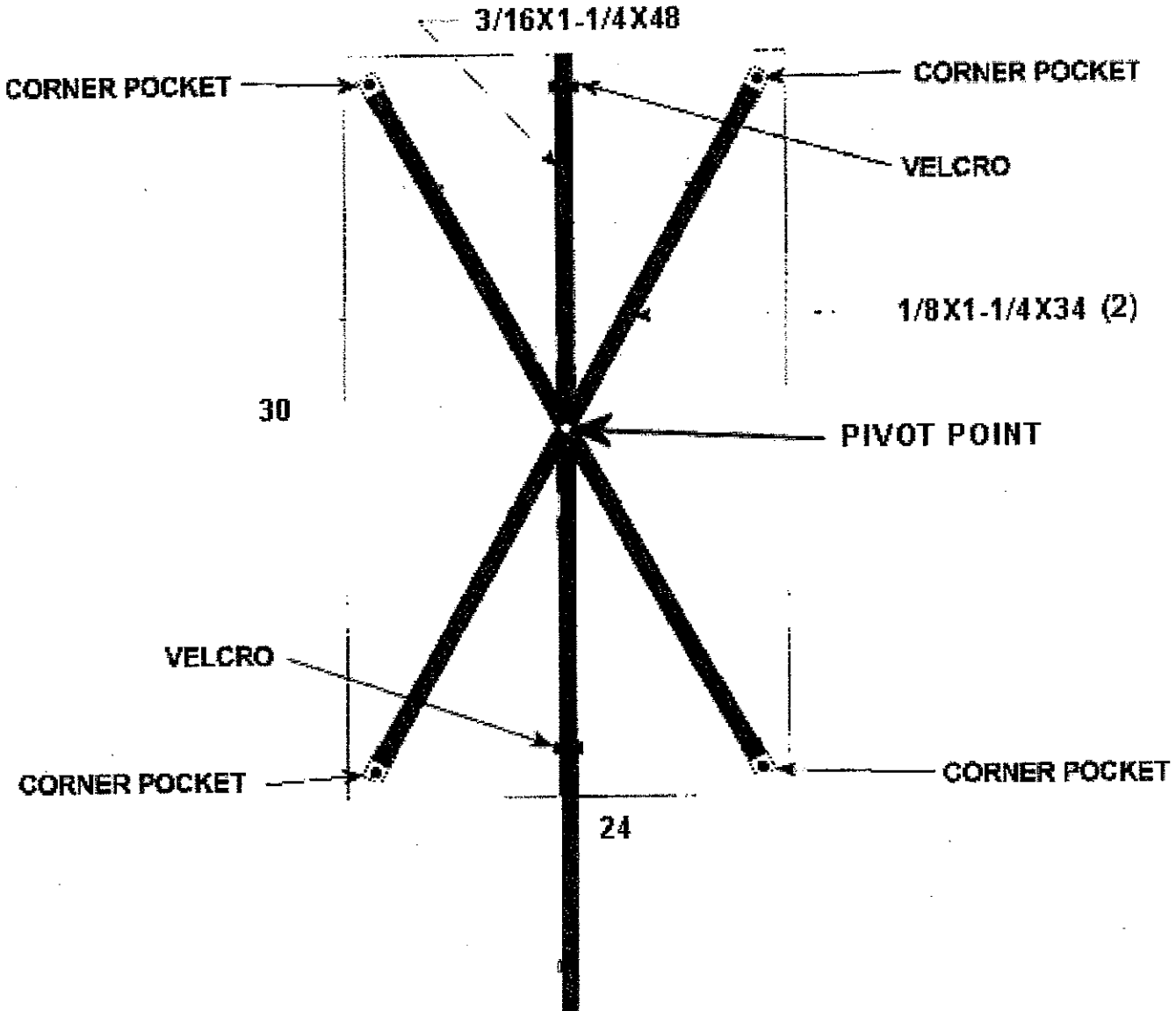

**36X48 VERTICAL RECTANGLE -  
CORNER POCKET AND RIB CONFIGURATION**

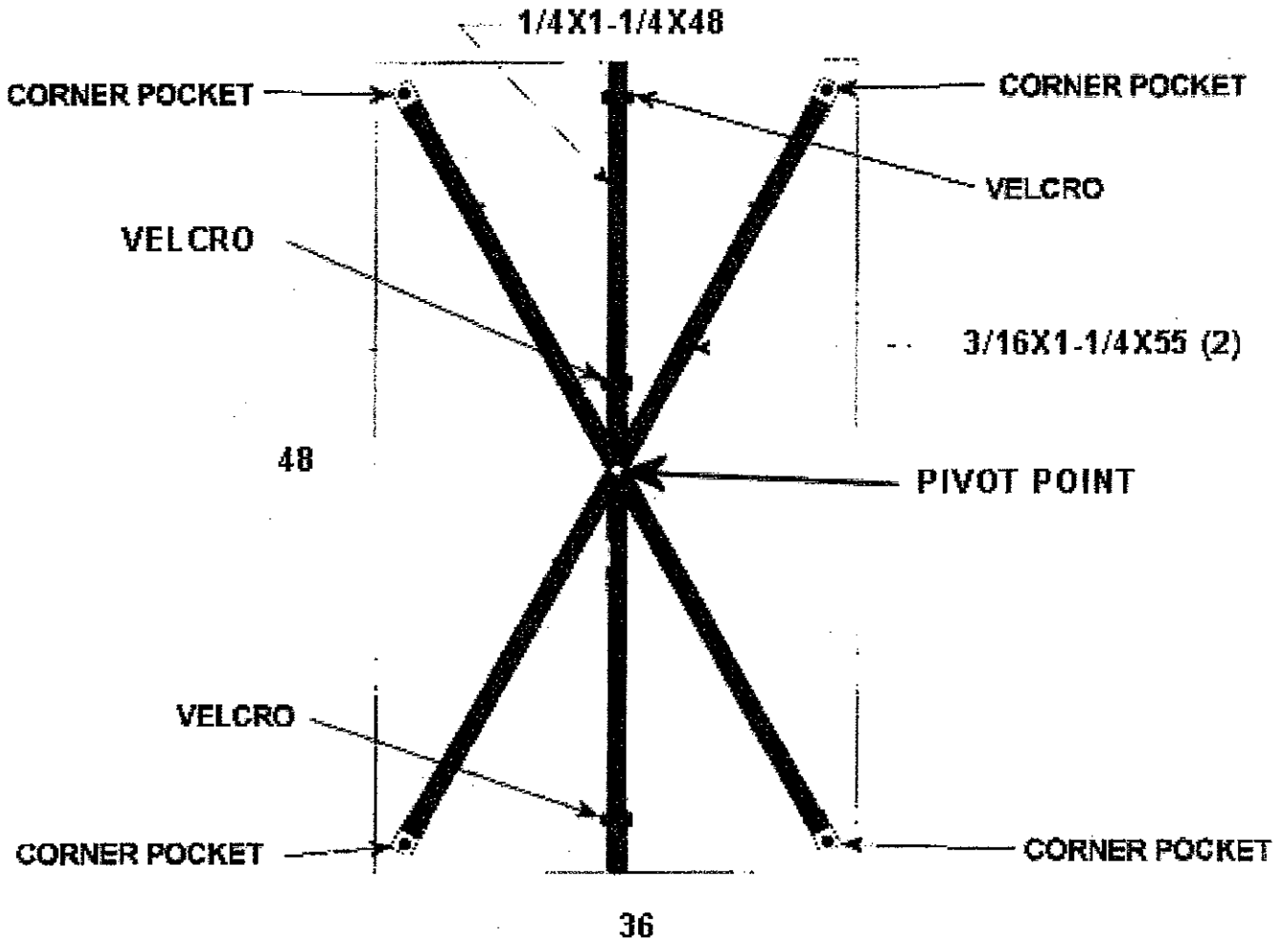

# 30X18 HORIZONTAL RECTANGLE - CORNER POCKET AND RIB CONFIGURATION

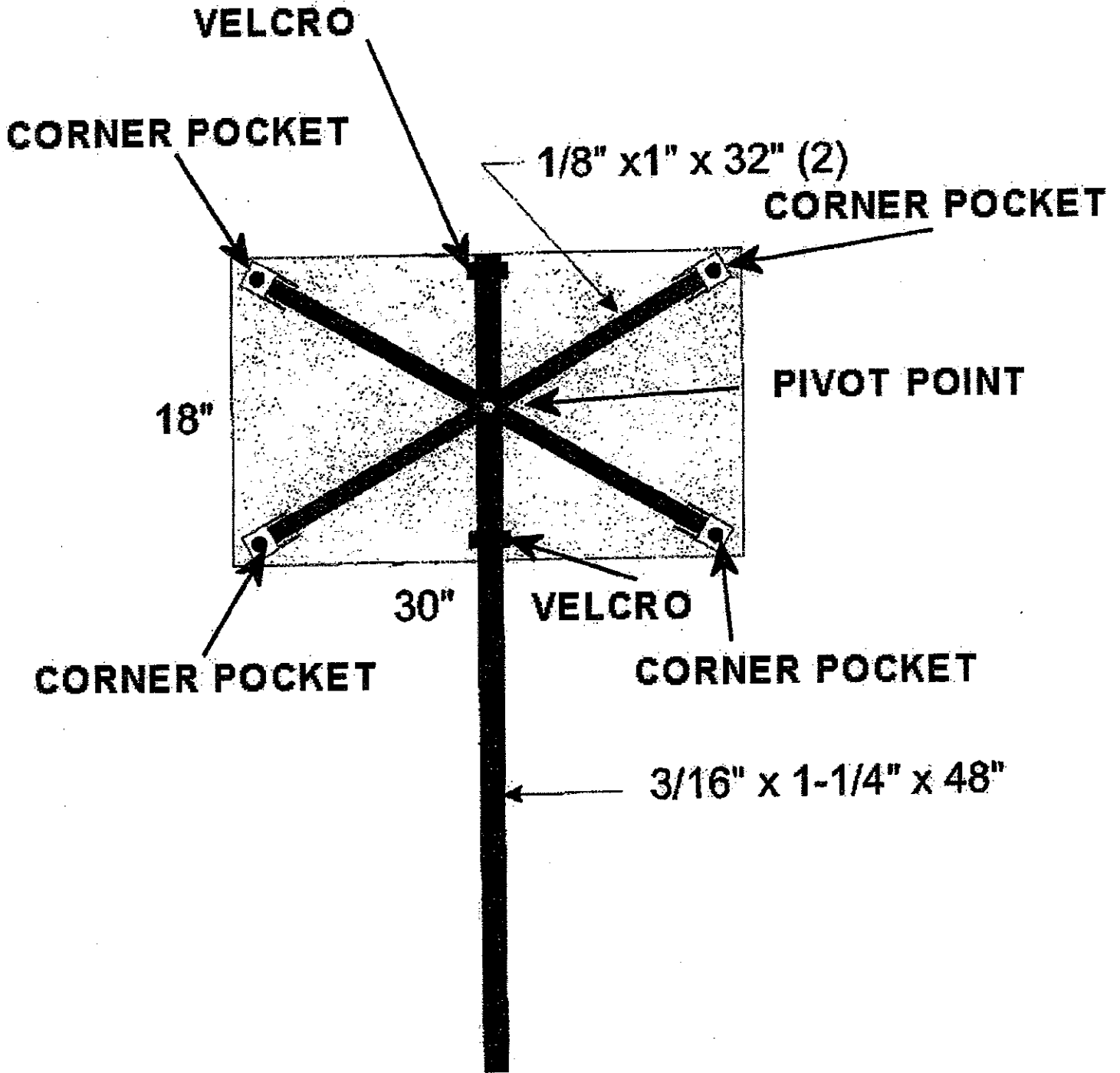

**48x30 HORIZONTAL RECTANGLE -  
CORNER POCKET AND RIB CONFIGURATION**

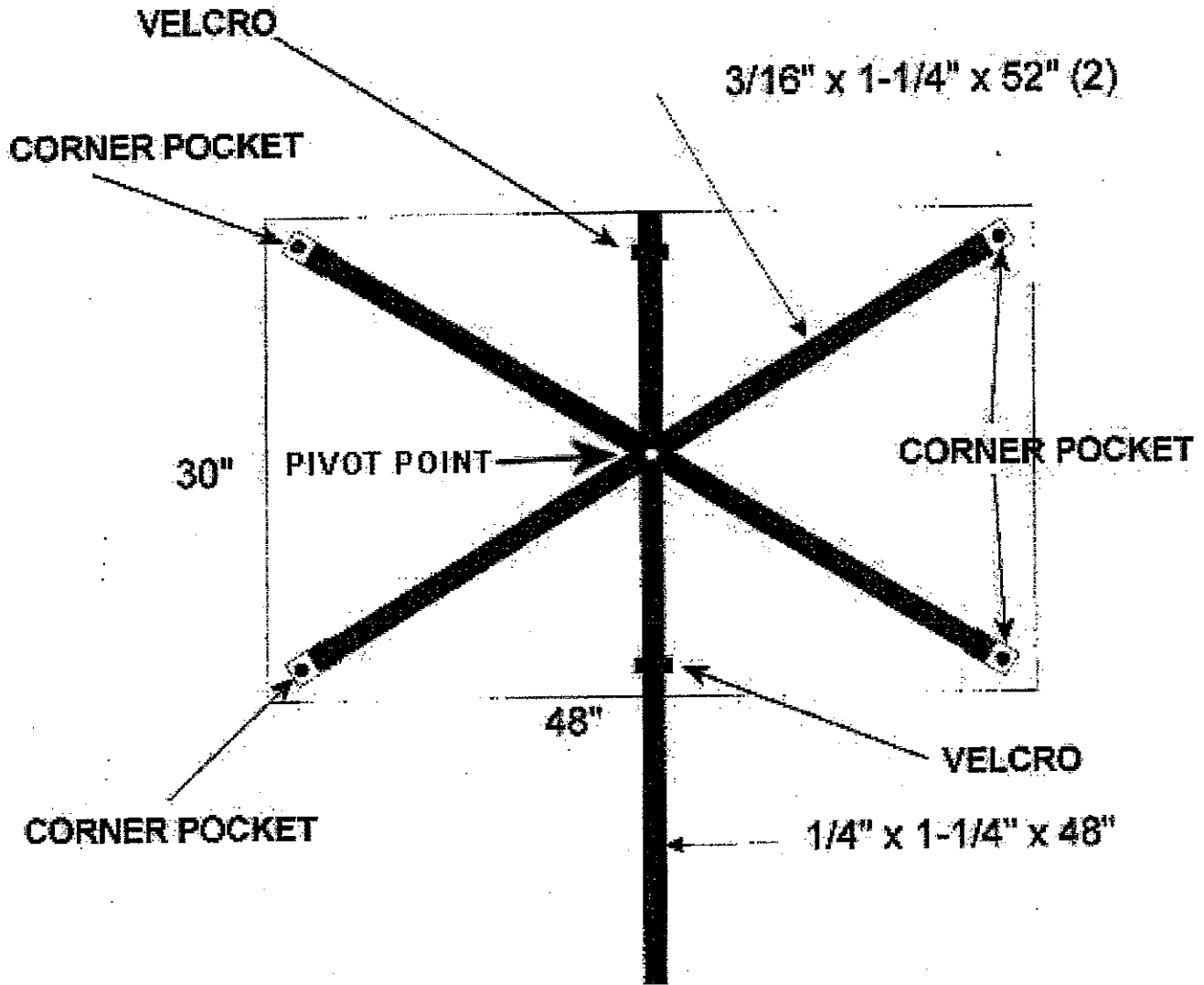

### 60X30 HORIZONTAL RECTANGLE - CORNER POCKET AND RIB CONFIGURATION

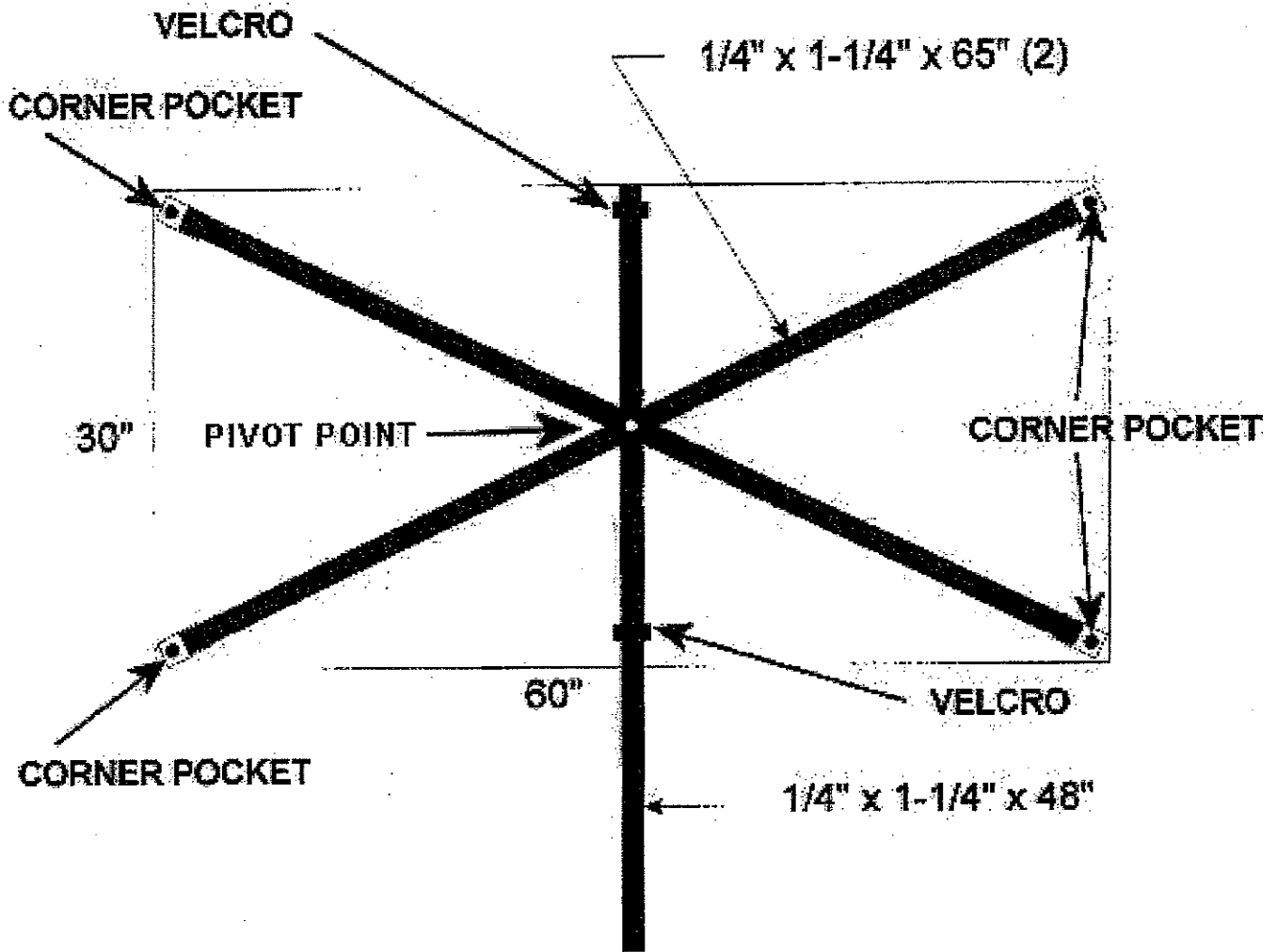

### 48x36 HORIZONTAL RECTANGLE - CORNER POCKET AND RIB CONFIGURATION

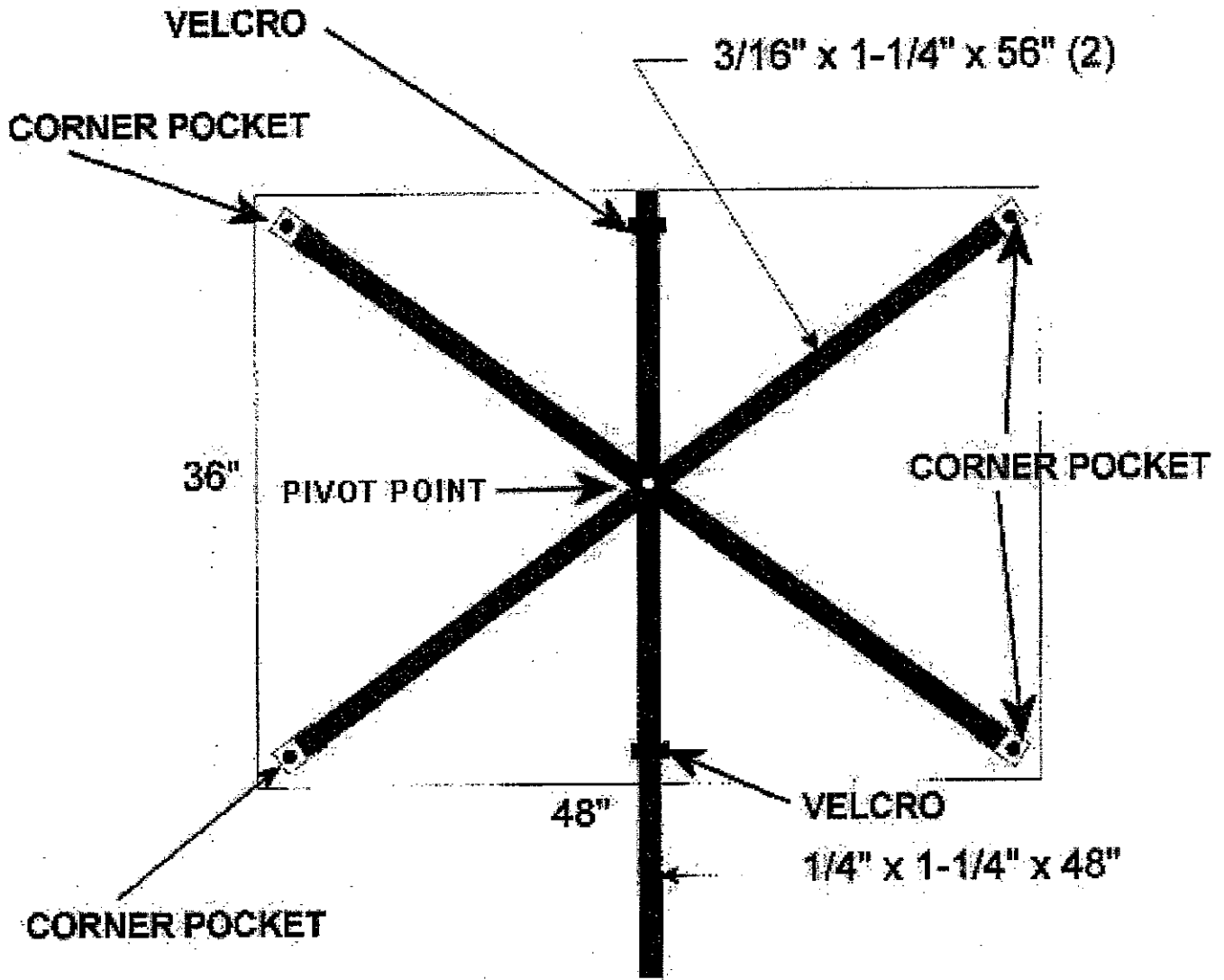

### 60X60 SQUARE - CORNER POCKET AND RIB CONFIGURATION

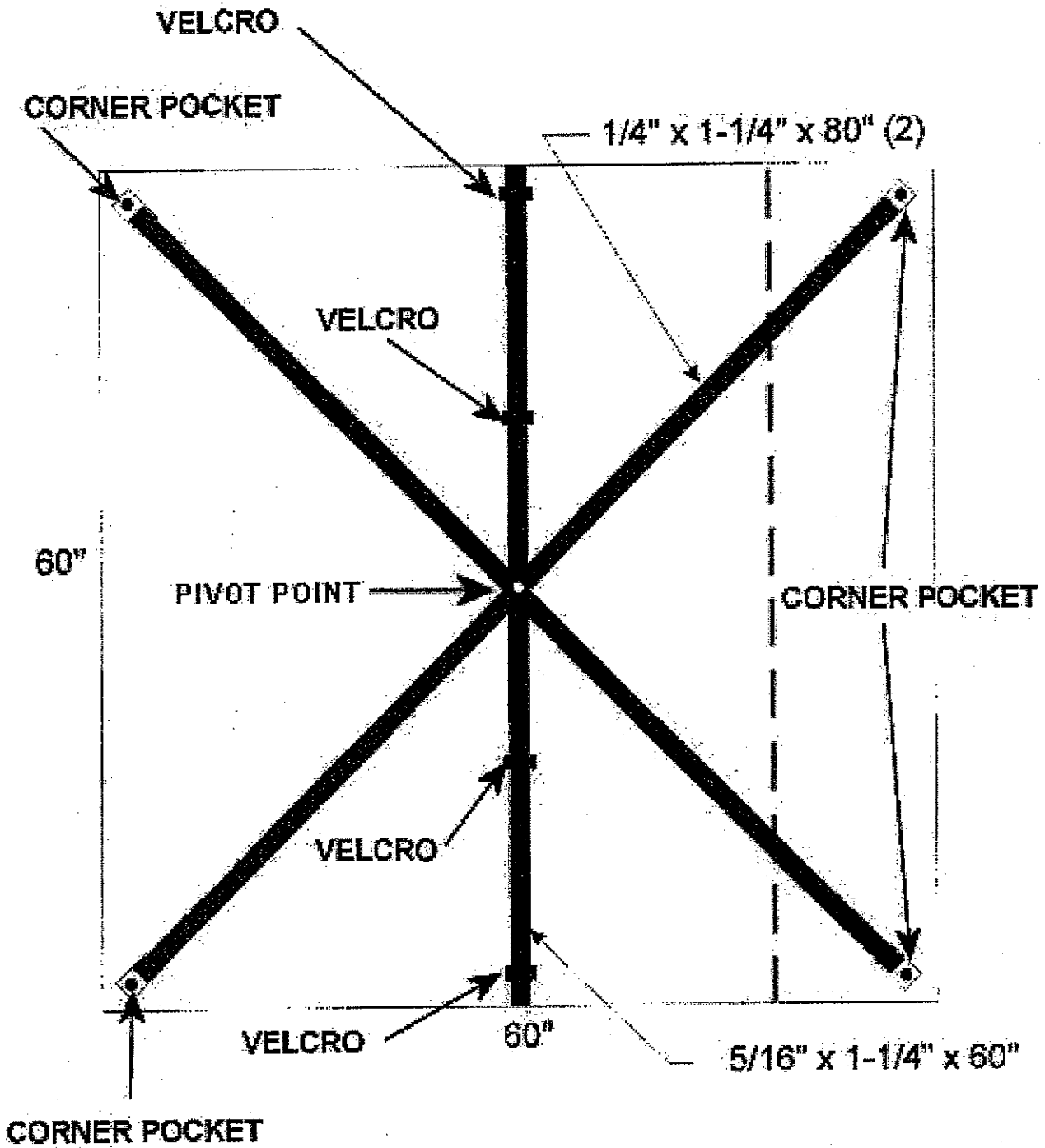



# 30X24 HORIZONTAL RECTANGLE - CORNER POCKET AND RIB CONFIGURATION

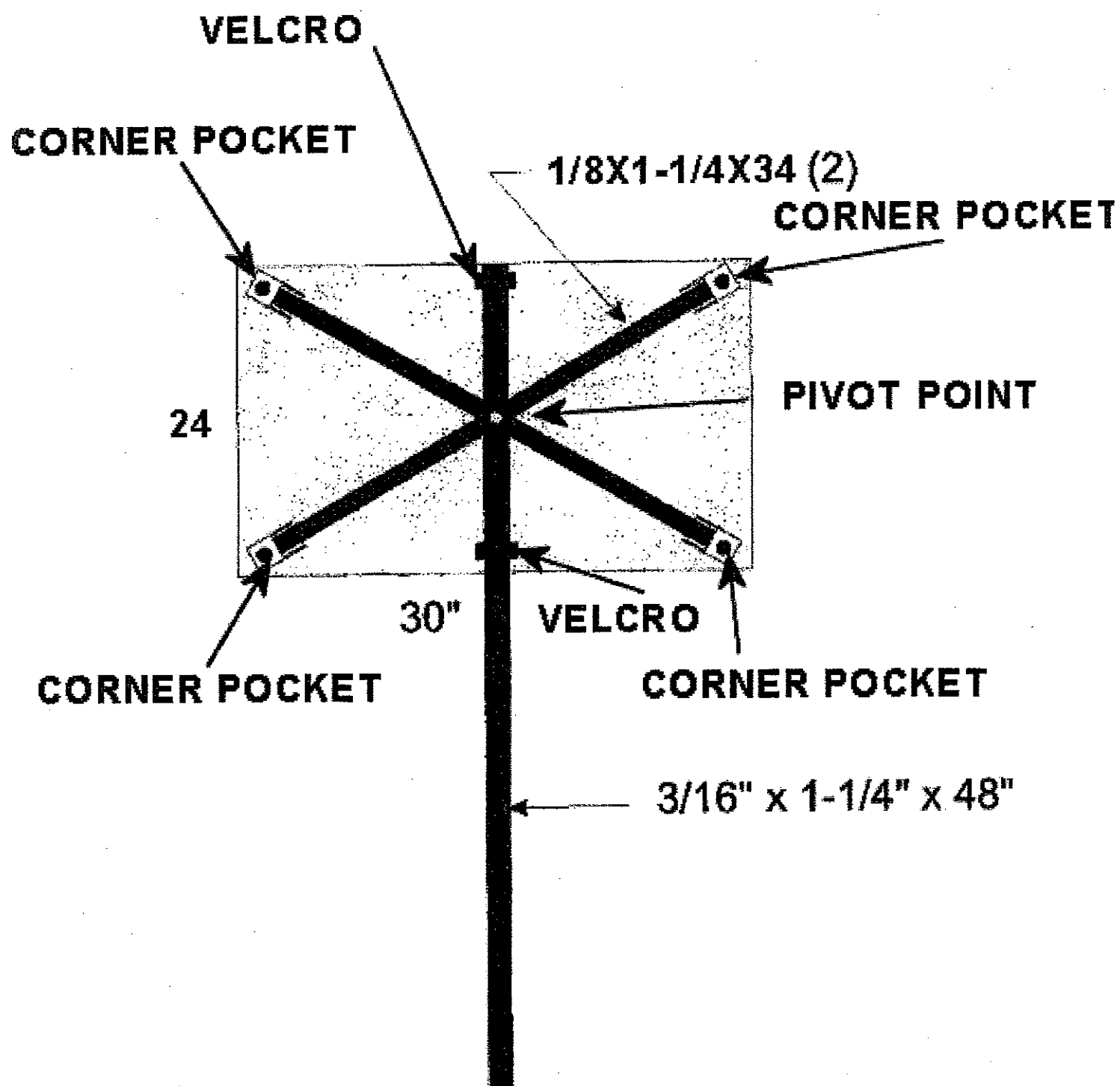

### 48x48 SQUARE - CORNER POCKET AND RIB CONFIGURATION

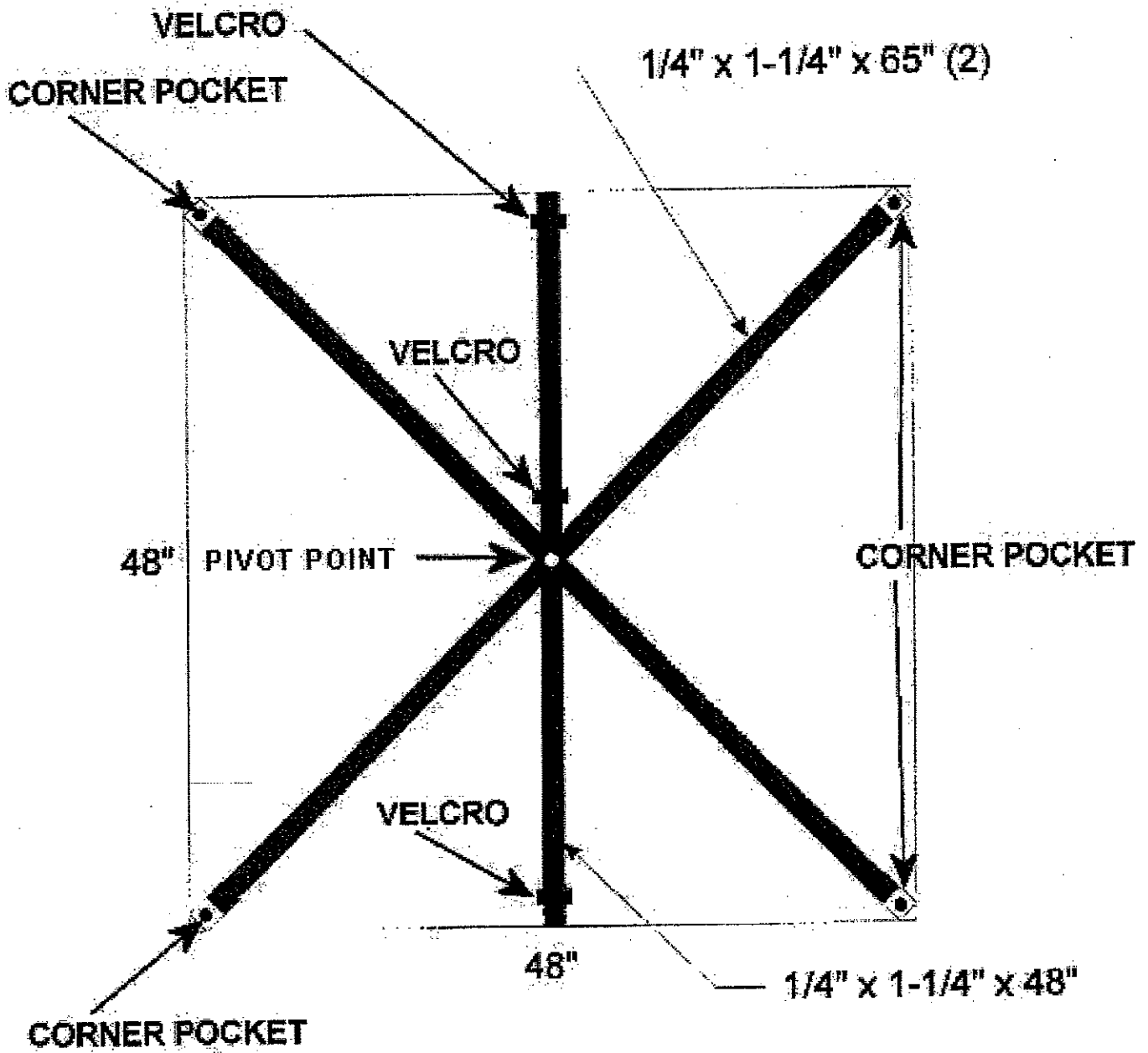

THE WEST VIRGINIA DEPARTMENT OF TRANSPORTATION  
DIVISION OF HIGHWAYS  
CHARLESTON, WEST VIRGINIA

ABSTRACT FROM THE RECORDS OF THE  
COMMISSIONER'S ORDERS  
DATED

September 23, 2004

MAILED  
09.28.04

Distribution:

- AC
- HD
- DT
- ERWA
- Division of Public Safety
- County Sheriff Departments
- Districts:
- All

Pursuant to authority vested in the Commissioner by Chapter 17, Article 6, Section 2, of the Official Code of West Virginia, 1931, as amended, the Commissioner, upon an engineering and traffic investigation, hereby ORDERS a speed limit in work zones on controlled access highways with four or more lanes as follows:

- 1) 55 MILES PER HOUR (mph) on all roadways with existing speed limits of 70 mph.
- 2) 50 MILES PER HOUR (mph) on all roadways with existing speed limits of 60 mph or 65 mph.
- 3) 45 MILES PER HOUR (mph) on all roadways with existing speed limits of 55 mph.
- 4) 40 MILES PER HOUR (mph) on all roadways with existing speed limits of 50 mph.

A work zone speed limit may be established in active work areas within the traveled way when at least one of the following conditions is satisfied:

- Road work activities cause the closure of a travel lane, OR
- Road work activities cause a reduction of the existing travel lane widths; OR
- Road work activities cause a temporary detour of the existing travel lanes.

This Order shall be effective when appropriate signs giving notice to the public have been installed in accordance with one of the two conditions noted below:

- For work areas that will be in existence for a period of time that exceeds one daylight operation - "WORK ZONE SPEED LIMIT WHEN FLASHING" signs shall be in place, flashers shall be appropriately attached to these signs and said flashers shall be in operation, OR
- For work areas that will be in existence for periods of time, not to exceed one daylight operation - "WORK ZONE SPEED LIMIT" signs shall be in place and all such signs shall be immediately removed or covered during: (a) non-working daylight hours, and (b) at the end of each daylight operation.

The authority to install the work zone speed limit shall be based on specific requirements contained in project plans, or by placing traffic control devices in accordance with the latest version of "Traffic Control for Street and Highway Construction and Maintenance Operations" Manual.

Entered this 23<sup>rd</sup> day of September, 2004

  
Fred Van Kirk, P.E.  
Secretary/Highways Commissioner

STATE OF WEST VIRGINIA  
WEST VIRGINIA DEPARTMENT OF TRANSPORTATION  
DIVISION OF HIGHWAYS

Given under my hand and seal of the Division of Highways, I do hereby certify that the foregoing is a true abstract from the Orders of the West Virginia Commissioner of Highways, entered of record on September 23, 2004.

  
Nancy L. Sample  
Division of Highways

**CONTACT PERSON AND DELIVERY ADDRESS FOR EACH  
DIVISION OF HIGHWAYS DESTINATION**

<b>Delivery Address</b>	<b>Contact</b>	<b>Phone Number</b>
WVDOH - D1 Sign Shop Pickens Rd. Nitro, WV 25143	Jim Russell	304-759-0708 304-558-3001*
WVDOH - D2 Sign Shop 801 Madison Ave. Huntington, WV 25704	Ed Layman	304-528-5679 304-528-5600*
WVDOH - D3 Sign Shop 720 Depot St. Parkersburg, WV 26101	Tom Potts	304-420-4815 304-420-4645*
WVDOH - D4 Sign Shop US-19 - 1 mile N. of Clarksburg (gore yard) Clarksburg, WV 26301	Rick Reed	304-627-2401 304-842-1500*
WVDOH - D5 Sign Shop US-50 - 14 miles E. of Keyser Burlington, WV 26710	Doug Placka	304-289-3521 304-289-3521*
WVDOH - D6 Sign Shop US-40 - E. of Wheeling (Middle Creek Rd. 39) Triadelphia, WV 26059	Jim Wurtzbacher	304-238-1205 304-238-4008*
WVDOH - D7 Sign Shop US-33 - 1/2 mile E. of Weston Weston, WV 26452	Tyrone Campbell	304-269-0460 304-269-0414*
WVDOH - D8 Sign Shop Rt. 219 - 1 mile N. of Elkins Elkins, WV 26241	Mike Westfall	304-637-0215 304-637-0220*
WVDOH - D9 Sign Shop US-219 - 1-1/2 miles N. of Lewisburg Country Club Rd. - Brush Rd. Lewisburg, WV 24901	Harry Honaker	304-647-7551 304-647-7450*
WVDOH - D10 Sign Shop 270 Hardwood Lane Princeton, WV 24740	Curtis Whitlow	304-487-5283 304-487-5228*
WVDOH - Traffic Services Complex 180 Dry Branch Rd. Charleston, WV 25306	Richard Rawling Ted Whitmore	304-558-6356 304-558-9468

\* District/Division headquarters phone number

# AFFIDAVIT

**West Virginia Code §5A-3-10a states:**

No contract or renewal of any contract may be awarded by the state or any of its political subdivisions to any vendor or prospective vendor when the vendor or prospective vendor or a related party to the vendor or prospective vendor is a debtor and the debt owned is an amount greater than one thousand dollars in the aggregate

**DEFINITIONS:**

"Debt" means any assessment, premium, penalty, fine, tax or other amount of money owed to the state or any of its political subdivisions because of a judgment, fine, permit violation, license assessment, defaulted workers' compensation premium, penalty or other assessment presently delinquent or due and required to be paid to the state or any of its political subdivisions, including any interest or additional penalties accrued thereon.

"Debtor" means any individual, corporation, partnership, association, limited liability company or any other form or business association owing a debt to the state or any of its political subdivisions. "Political subdivision" means any county commission; municipality; county board of education; any instrumentality established by a county or municipality; any separate corporation or instrumentality established by one or more counties or municipalities, as permitted by law; or any public body charged by law with the performance of a government function or whose jurisdiction is coextensive with one or more counties or municipalities. "Related party" means a party, whether an individual, corporation, partnership, association, limited liability company or any other form or business association or other entity whatsoever, related to any vendor by blood, marriage, ownership or contract through which the party has a relationship of ownership or other interest with the vendor so that the party will actually or by effect receive or control a portion of the benefit, profit or other consideration from performance of a vendor contract with the party receiving an amount that meets or exceed five percent of the total contract amount.

**EXCEPTION:**

The prohibition of this section does not apply where a vendor has contested any tax administered pursuant to chapter eleven of this code, workers' compensation premium, permit fee or environmental fee or assessment and the matter has not become final or where the vendor has entered into a payment plan or agreement and the vendor is not in default of any of the provisions of such plan or agreement.

**LICENSING:**

Vendors must be licensed and in good standing in accordance with any and all state and local laws and requirements by any state or local agency of West Virginia, including, but not limited to, the West Virginia Secretary of State's Office, the West Virginia Tax Department, West Virginia Insurance Commission, or any other state agencies or political subdivision. Furthermore, the vendor must provide all necessary releases to obtain information to enable the Director or spending unit to verify that the vendor is licensed and in good standing with the above entities.

**CONFIDENTIALITY:**

The vendor agrees that he or she will not disclose to anyone, directly or indirectly, any such personally identifiable information or other confidential information gained from the agency, unless the individual who is the subject of the information consents to the disclosure in writing or the disclosure is made pursuant to the agency's policies, procedures and rules. Vendors should visit [www.state.wv.us/admin/purchase/privacy](http://www.state.wv.us/admin/purchase/privacy) for the Notice of Agency Confidentiality Policies.

Under penalty of law for false swearing (West Virginia Code, §61-5-3), it is hereby certified that the vendor acknowledges the information in this said affidavit and are in compliance with the requirements as stated.

Vendor's Name: MARKY DAVIES, INC.

Authorized Signature: [Signature] Date: 4/25/07

WUE EDWARDS