



State of West Virginia
 Department of Administration
 Purchasing Division
 2019 Washington Street East
 Post Office Box 50130
 Charleston, WV 25305-0130

Request for Quotation

RFQ NUMBER
707EC020

PAGE
1

ADDRESS CORRESPONDENCE TO ATTENTION OF
JOHN JOHNSTON
304-558-2402

VENDOR

*709014709 01 304-366-3075
 ANDERSON EQUIPMENT COMPANY
 7 RUSKIN DRIVE
 FAIRMONT WV 26554

SHIP TO

DIVISION OF HIGHWAYS
 EQUIPMENT DIVISION
 ROUTE 33
 BRUSHY FORK ROAD
 BUCKHANNON, WV
 26201 304-472-1750

DATE PRINTED	TERMS OF SALE	SHIP VIA	F.O.B.	FREIGHT TERMS
03/07/2007	Net 30 days	Anderson Equip.	Buckhannon, WV	Delivered

BID OPENING DATE: **04/11/2007** BID OPENING TIME **01:30PM**

LINE	QUANTITY	UOP	CAT NO	ITEM NUMBER	UNIT PRICE	AMOUNT
0001	1	EA		760-51		\$312,338.98/each
<p>SKID STEER LOADER WITH ATTACHMENTS</p> <p>OPEN END CONTRACT</p> <p>TO PROVIDE SKID STEER LOADER WITH ATTACHMENTS AS DESCRIBED IN ATTACHED PROCUREMENT SPECIFICATION 351-2-F</p> <p>THERE WILL BE A MANDATORY PRE-BID CONFERENCE AT THE STATE CAPITOL COMPLEX, BUILDING 15, CONFERENCE ROOM, AT 10:00 AM ON 3/29/07. FAILURE TO ATTEND THE PRE-BID CONFERENCE WILL RESULT IN BID DISQUALIFICATION.</p> <p>QUESTIONS: WRITTEN QUESTIONS WILL BE ACCEPTED THROUGH CLOSE OF BUSINESS (5:00PM EST) ON TUESDAY, 3/20/07.</p> <p>SEND YOUR QUESTIONS TO: PURCHASING DIVISION ATTENTION JOHN JOHNSTON 2019 WASHINGTON ST. E. CHARLESTON, WV. 25305</p> <p>QUESTIONS MAY BE SENT VIA FAX, E-MAIL, OR REGULAR MAIL E-MAIL: JJOHNSTON@WVADMIN.GOV FAX: 304-558-4115</p> <p>IT IS THE VENDORS RESPONSIBILITY TO VERIFY THAT THEIR QUESTIONS HAVE BEEN RECEIVED BY CALLING 304-558-2402.</p> <p>EXHIBIT 2</p> <p>LIFE OF CONTRACT: THIS CONTRACT BECOMES EFFECTIVE ON AND EXTENDS FOR A PERIOD OF ONE (1) YEAR OR UNTIL SUCH "REASONABLE TIME" THEREAFTER AS IS NECESSARY TO OBTAIN A NEW CONTRACT OR RENEW THE</p>						

RECEIVED

2007 MAY -9 P 1:07

PURCHASING DIVISION
 STATE OF WV

SEE REVERSE SIDE FOR TERMS AND CONDITIONS

SIGNATURE	TELEPHONE	DATE
<i>Michael R. Burke</i>	304-756-2800	5/8/07
TITLE	FEIN	ADDRESS CHANGES TO BE NOTED ABOVE
General Manager-WV	25-032-3970	

WHEN RESPONDING TO RFQ, INSERT NAME AND ADDRESS IN SPACE ABOVE LABELED 'VENDOR'



State of West Virginia
 Department of Administration
 Purchasing Division
 2019 Washington Street East
 Post Office Box 50130
 Charleston, WV 25305-0130

Request for Quotation

RFQ NUMBER
707EC020

PAGE
2

ADDRESS CORRESPONDENCE TO ATTENTION OF:
JOHN JOHNSTON
304-558-2402

VENDOR

*709014709 01 304-366-3075
ANDERSON EQUIPMENT COMPANY
7 RUSKIN DRIVE

FAIRMONT WV 26554

SHIP TO

DIVISION OF HIGHWAYS
EQUIPMENT DIVISION
ROUTE 33
BRUSHY FORK ROAD
BUCKHANNON, WV
26201 **304-472-1750**

DATE PRINTED 03/07/2007	TERMS OF SALE	SHIP VIA	F.O.B.	FREIGHT TERMS
-----------------------------------	---------------	----------	--------	---------------

BID OPENING DATE: **04/11/2007** BID OPENING TIME **01:30PM**

LINE	QUANTITY	UOP	CAT NO.	ITEM NUMBER	UNIT PRICE	AMOUNT
<p>ORIGINAL CONTRACT. THE "REASONABLE TIME" PERIOD SHALL NOT EXCEED TWELVE (12) MONTHS. DURING THIS "REASONABLE TIME" THE VENDOR MAY TERMINATE THIS CONTRACT FOR ANY REASON UPON GIVING THE DIRECTOR OF PURCHASING THIRTY (30) DAYS WRITTEN NOTICE.</p> <p>UNLESS SPECIFIC PROVISIONS ARE STIPULATED IN THIS CONTRACT DOCUMENT, THE TERMS, CONDITIONS, AND PRICING SET HEREIN ARE FIRM FOR THE LIFE OF THE CONTRACT.</p> <p>RENEWAL: THIS CONTRACT MAY BE RENEWED UPON THE MUTUAL WRITTEN CONSENT OF THE SPENDING UNIT AND VENDOR, SUBMITTED TO THE DIRECTOR OF PURCHASING THIRTY (30) DAYS PRIOR TO THE EXPIRATION DATE. SUCH RENEWAL SHALL BE IN ACCORDANCE WITH THE TERMS AND CONDITIONS OF THE ORIGINAL CONTRACT AND SHALL BE LIMITED TO TWO (2) ONE (1) YEAR PERIODS.</p> <p>CANCELLATION: THE DIRECTOR OF PURCHASING RESERVES THE RIGHT TO CANCEL THIS CONTRACT IMMEDIATELY UPON WRITTEN NOTICE TO THE VENDOR IF THE COMMODITIES AND/OR SERVICES SUPPLIED ARE OF AN INFERIOR QUALITY OR DO NOT CONFORM WITH THE SPECIFICATIONS OF THE BID AND CONTRACT HEREIN.</p> <p>OPEN MARKET CLAUSE: THE DIRECTOR OF PURCHASING MAY AUTHORIZE A SPENDING UNIT TO PURCHASE ON THE OPEN MARKET, WITHOUT THE FILING OF A REQUISITION OR COST ESTIMATE, ITEMS SPECIFIED ON THIS CONTRACT FOR IMMEDIATE DELIVERY IN EMERGENCIES DUE TO UNFORESEEN CAUSES (INCLUDING BUT NOT LIMITED TO DELAYS IN TRANSPORTATION OR AN UNANTICIPATED INCREASE IN THE VOLUME OF WORK).</p> <p>QUANTITIES: QUANTITIES LISTED IN THE REQUISITION ARE APPROXIMATIONS ONLY, BASED ON ESTIMATES SUPPLIES BY THE STATE SPENDING UNIT. IT IS UNDERSTOOD AND AGREED THAT THE CONTRACT SHALL COVER THE QUANTITIES ACTUALLY</p>						

SEE REVERSE SIDE FOR TERMS AND CONDITIONS

SIGNATURE	TELEPHONE	DATE
TITLE	FEIN	ADDRESS CHANGES TO BE NOTED ABOVE

WHEN RESPONDING TO RFQ, INSERT NAME AND ADDRESS IN SPACE ABOVE LABELED 'VENDOR'



State of West Virginia
 Department of Administration
 Purchasing Division
 2019 Washington Street East
 Post Office Box 50130
 Charleston, WV 25305-0130

Request for Quotation

RFQ NUMBER
707EC020

PAGE
3

ADDRESS CORRESPONDENCE TO ATTENTION OF
JOHN JOHNSTON 304-558-2402

VENDOR

*709014709 01 304-366-3075
 ANDERSON EQUIPMENT COMPANY
 7 RUSKIN DRIVE

 FAIRMONT WV 26554

SHIP TO

DIVISION OF HIGHWAYS
 EQUIPMENT DIVISION
 ROUTE 33
 BRUSHY FORK ROAD
 BUCKHANNON, WV
 26201 304-472-1750

DATE PRINTED	TERMS OF SALE	SHIP VIA	F.O.B.	FREIGHT TERMS
03/07/2007				

BID OPENING DATE: 04/11/2007 BID OPENING TIME 01:30PM

LINE	QUANTITY	UOP	CAT NO.	ITEM NUMBER	UNIT PRICE	AMOUNT
<p>ORDERED FOR DELIVERY DURING THE TERM OF CONTRACT, WHETHER MORE OR LESS THAN THE QUANTITIES SHOWN.</p> <p>ORDERING PROCEDURE: SPENDING UNIT(S) SHALL ISSUE A WRITTEN EQUIPMENT CONTRACT ORDER (FORM NUMBER WV-35) FOR COMMODITIES COVERED BY THIS CONTRACT. THE ORIGINAL WV-35 MUST BE SENT TO THE PURCHASING DIVISION OF THE DEPARTMENT OF ADMINISTRATION. AFTER APPROVAL AND ENCUMBRANCE, ONE COPY OF THE PURCHASE ORDER WILL BE RETURNED TO THE SPENDING UNIT AND ONE COPY FORWARDED TO THE VENDOR AS AUTHORIZATION FOR SHIPMENT. NO ORDER IS VALID UNLESS APPROVED AND ENCUMBERED BY THE PURCHASING DIVISION.</p> <p>BANKRUPTCY: IN THE EVENT THE VENDOR/CONTRACTOR FILES FOR BANKRUPTCY PROTECTION, THIS CONTRACT IS AUTOMATICALLY NULL AND VOID, AND IS TERMINATED WITHOUT FURTHER ORDER.</p> <p>REV. 9/98</p> <p>EXHIBIT 6</p> <p>PRICE ADJUSTMENT PROVISION: THE STATE OF WEST VIRGINIA WILL CONSIDER BIDS THAT CONTAIN PROVISIONS FOR PRICE ADJUSTMENTS PRIOR TO THE ORIGINAL EXPIRATION OF THE CONTRACT, PROVIDED THAT SUCH PRICE ADJUSTMENT COVERS BOTH UPWARD AND DOWNWARD MOVEMENT OF THE COMMODITY PRICE, AND THAT ADJUSTMENT IS BASED ON THE "PASS THROUGH" INCREASE OR DECREASE OF RAW MATERIALS AND/OR LABOR, WHICH MAKE UP ALL OR A SUBSTANTIAL PART OF A PRODUCT. ADJUSTMENTS ARE TO BE BASED UPON AN ACTUAL DOLLAR FIGURE, NOT A PERCENTAGE. ALL PRICE ADJUSTMENT REQUESTS MUST BE SUBSTANTIATED IN A MANNER ACCEPTABLE TO THE DIRECTOR PURCHASING, E.G.</p>						

SEE REVERSE SIDE FOR TERMS AND CONDITIONS

SIGNATURE	TELEPHONE	DATE
TITLE	FEIN	ADDRESS CHANGES TO BE NOTED ABOVE

WHEN RESPONDING TO RFQ, INSERT NAME AND ADDRESS IN SPACE ABOVE LABELED 'VENDOR'



State of West Virginia
 Department of Administration
 Purchasing Division
 2019 Washington Street East
 Post Office Box 50130
 Charleston, WV 25305-0130

Request for Quotation

RFQ NUMBER
707EC020

PAGE
4

ADDRESS CORRESPONDENCE TO ATTENTION OF:
JOHN JOHNSTON 304-558-2402

VENDOR

*709014709 01 304-366-3075
 ANDERSON EQUIPMENT COMPANY
 7 RUSKIN DRIVE
 FAIRMONT WV 26554

SHIP TO

DIVISION OF HIGHWAYS
 EQUIPMENT DIVISION
 ROUTE 33
 BRUSHY FORK ROAD
 BUCKHANNON, WV
 26201 304-472-1750

DATE PRINTED	TERMS OF SALE	SHIP VIA	F.O.B.	FREIGHT TERMS
03/07/2007				

BID OPENING DATE: 04/11/2007 BID OPENING TIME 01:30PM

LINE	QUANTITY	UOP	CAT NO	ITEM NUMBER	UNIT PRICE	AMOUNT
<p>GOVERNMENTAL BENCH MARKS, GENERAL MARKET INCREASE, PUBLISHED PRICE LISTS. SUCH REQUESTS FOR AND INCREASE SHOULD BE RECEIVED IN WRITING BY THE DIRECTOR OF PURCHASING AT LEAST 30 DAYS IN ADVANCE OF THE EFFECTIVE DATE OF THE INCREASE. ANY TIME THE VENDOR REQUESTS A PRICE ADJUSTMENT, THE PURCHASING DIVISION MAY EITHER ACCEPT THE PRICE ADJUSTMENT AND AMEND THE CONTRACT ACCORDINGLY OR REJECT THE ADJUSTMENT IN ITS ENTIRETY AND CANCEL THE CONTRACT.</p> <p>EXHIBIT 4</p> <p>LOCAL GOVERNMENT BODIES: UNLESS THE VENDOR INDICATES IN THE BID HIS REFUSAL TO EXTEND THE PRICES, TERMS, AND CONDITIONS OF THE BID TO COUNTY, SCHOOL, MUNICIPAL AND OTHER LOCAL GOVERNMENT BODIES, THE BID SHALL EXTEND TO POLITICAL SUBDIVISIONS OF THE STATE OF WEST VIRGINIA. IF THE VENDOR DOES NOT WISH TO EXTEND THE PRICES, TERMS, AND CONDITIONS OF THE BID TO ALL POLITICAL SUBDIVISIONS OF THE STATE, THE VENDOR MUST CLEARLY INDICATE SUCH REFUSAL IN HIS BID. SUCH REFUSAL SHALL NOT PREJUDICE THE AWARD OF THIS CONTRACT IN ANY MANNER.</p> <p>REV. 3/88</p> <p>VENDOR PREFERENCE CERTIFICATE</p> <p>CERTIFICATION AND APPLICATION* IS HEREBY MADE FOR PREFERENCE IN ACCORDANCE WITH WEST VIRGINIA CODE, 5A-3-37 (DOES NOT APPLY TO CONSTRUCTION CONTRACTS).</p> <p>A. APPLICATION IS MADE FOR 2.5% PREFERENCE FOR THE REASON CHECKED:</p> <p>() BIDDER IS AN INDIVIDUAL RESIDENT VENDOR AND</p>						

SEE REVERSE SIDE FOR TERMS AND CONDITIONS

SIGNATURE	TELEPHONE	DATE
-----------	-----------	------

TITLE	FEIN	ADDRESS CHANGES TO BE NOTED ABOVE
-------	------	-----------------------------------

WHEN RESPONDING TO RFQ, INSERT NAME AND ADDRESS IN SPACE ABOVE LABELED 'VENDOR'



State of West Virginia
 Department of Administration
 Purchasing Division
 2019 Washington Street East
 Post Office Box 50130
 Charleston, WV 25305-0130

Request for Quotation

RFQ NUMBER
 707EC020

PAGE
 5

ADDRESS CORRESPONDENCE TO ATTENTION OF:
 JOHN JOHNSTON
 304-558-2402

VENDOR

*709014709 01 304-366-3075
 ANDERSON EQUIPMENT COMPANY
 7 RUSKIN DRIVE
 FAIRMONT WV 26554

SHIP TO

DIVISION OF HIGHWAYS
 EQUIPMENT DIVISION
 ROUTE 33
 BRUSHY FORK ROAD
 BUCKHANNON, WV
 26201 304-472-1750

DATE PRINTED 03/07/2007	TERMS OF SALE	SHIP VIA	F.O.B.	FREIGHT TERMS
BID OPENING DATE: 04/11/2007 BID OPENING TIME 01:30PM				

LINE	QUANTITY	UOP	CAT. NO.	ITEM NUMBER	UNIT PRICE	AMOUNT
				<p>HAS RESIDED CONTINUOUSLY IN WEST VIRGINIA FOR FOUR (4) YEARS IMMEDIATELY PRECEDING THE DATE OF THIS CERTIFICATION; OR</p> <p>(X) BIDDER IS A PARTNERSHIP, ASSOCIATION OR CORPORATION RESIDENT VENDOR AND HAS MAINTAINED ITS HEAD-QUARTERS OR PRINCIPAL PLACE OF BUSINESS CONTINUOUSLY IN WEST VIRGINIA FOR FOUR (4) YEARS IMMEDIATELY PRECEDING THE DATE OF THIS CERTIFICATION; OR 80% OF THE OWNERSHIP INTEREST OF BIDDER IS HELD BY ANOTHER INDIVIDUAL, PARTNERSHIP, ASSOCIATION OR CORPORATION RESIDENT VENDOR WHO HAS MAINTAINED ITS HEADQUARTERS OR PRINCIPAL PLACE OF BUSINESS CONTINUOUSLY IN WEST VIRGINIA FOR FOUR (4) YEARS IMMEDIATELY PRECEDING THE DATE OF THIS CERTIFICATION; OR</p> <p>() BIDDER IS A CORPORATION NONRESIDENT VENDOR WHICH HAS AN AFFILIATE OR SUBSIDIARY WHICH EMPLOYS A MINIMUM OF ONE HUNDRED STATE RESIDENTS AND WHICH HAS MAINTAINED ITS HEADQUARTERS OR PRINCIPAL PLACE OF BUSINESS WITHIN WEST VIRGINIA CONTINUOUSLY FOR THE FOUR (4) YEARS IMMEDIATELY PRECEDING THE DATE OF THIS CERTIFICATION.</p> <p>B. APPLICATION IS MADE FOR 2.5% PREFERENCE FOR THE REASON CHECKED:</p> <p>() BIDDER IS A RESIDENT VENDOR WHO CERTIFIES THAT, DURING THE LIFE OF THE CONTRACT, ON AVERAGE AT LEAST 75% OF THE EMPLOYEES WORKING ON THE PROJECT BEING BID ARE RESIDENTS OF WEST VIRGINIA WHO HAVE RESIDED IN THE STATE CONTINUOUSLY FOR THE TWO YEARS IMMEDIATELY PRECEDING SUBMISSION OF THIS BID;</p> <p>OR</p> <p>() BIDDER IS A NONRESIDENT VENDOR EMPLOYING A MINIMUM OF ONE HUNDRED STATE RESIDENTS OR IS A</p>		

SEE REVERSE SIDE FOR TERMS AND CONDITIONS			
SIGNATURE	TELEPHONE	DATE	
TITLE	FEIN	ADDRESS CHANGES TO BE NOTED ABOVE	

WHEN RESPONDING TO RFQ, INSERT NAME AND ADDRESS IN SPACE ABOVE LABELED 'VENDOR'



State of West Virginia
 Department of Administration
 Purchasing Division
 2019 Washington Street East
 Post Office Box 50130
 Charleston, WV 25305-0130

Request for Quotation

RFQ NUMBER
707EC020

PAGE
6

ADDRESS CORRESPONDENCE TO ATTENTION OF
**JOHN JOHNSTON
 304-558-2402**

VENDOR

*709014709 01 304-366-3075
**ANDERSON EQUIPMENT COMPANY
 7 RUSKIN DRIVE
 FAIRMONT WV 26554**

SHIP TO

**DIVISION OF HIGHWAYS
 EQUIPMENT DIVISION
 ROUTE 33
 BRUSHY FORK ROAD
 BUCKHANNON, WV
 26201 304-472-1750**

DATE PRINTED 03/07/2007	TERMS OF SALE	SHIP VIA	F.O.B.	FREIGHT TERMS
BID OPENING DATE: 04/11/2007		BID OPENING TIME 01:30PM		

LINE	QUANTITY	UOP	CAT NO.	ITEM NUMBER	UNIT PRICE	AMOUNT
<p>NONRESIDENT VENDOR WITH AN AFFILIATE OR SUBSIDIARY WHICH MAINTAINS ITS HEADQUARTERS OR PRINCIPAL PLACE OF BUSINESS WITHIN WEST VIRGINIA EMPLOYING A MINIMUM OF ONE HUNDRED STATE RESIDENTS WHO CERTIFIES THAT, DURING THE LIFE OF THE CONTRACT, ON AVERAGE AT LEAST 75% OF THE EMPLOYEES OR BIDDERS' AFFILIATE'S OR SUBSIDIARY'S EMPLOYEES ARE RESIDENTS OF WEST VIRGINIA WHO HAVE RESIDED IN THE STATE CONTINUOUSLY FOR THE TWO YEARS IMMEDIATELY PRECEDING SUBMISSION OF THIS BID.</p> <p>BIDDER UNDERSTANDS IF THE SECRETARY OF TAX & REVENUE DETERMINES THAT A BIDDER RECEIVING PREFERENCE HAS FAILED TO CONTINUE TO MEET THE REQUIREMENTS FOR SUCH PREFERENCE, THE SECRETARY MAY ORDER THE DIRECTOR OF PURCHASING TO: (A) RESCIND THE CONTRACT OR PURCHASE ORDER ISSUED; OR (B) ASSESS A PENALTY AGAINST SUCH BIDDER IN AN AMOUNT NOT TO EXCEED 5% OF THE BID AMOUNT AND THAT SUCH PENALTY WILL BE PAID TO THE CONTRACTING AGENCY OR DEDUCTED FROM ANY UNPAID BALANCE ON THE CONTRACT OR PURCHASE ORDER.</p> <p>BY SUBMISSION OF THIS CERTIFICATE, BIDDER AGREES TO DISCLOSE ANY REASONABLY REQUESTED INFORMATION TO THE PURCHASING DIVISION AND AUTHORIZES THE DEPARTMENT OF TAX AND REVENUE TO DISCLOSE TO THE DIRECTOR OF PURCHASING APPROPRIATE INFORMATION VERIFYING THAT BIDDER HAS PAID THE REQUIRED BUSINESS TAXES, PROVIDED THAT SUCH INFORMATION DOES NOT CONTAIN THE AMOUNTS OF TAXES PAID NOR ANY OTHER INFORMATION DEEMED BY THE TAX COMMISSIONER TO BE CONFIDENTIAL.</p> <p>UNDER PENALTY OF LAW FOR FALSE SWEARING (WEST VIRGINIA CODE 61-5-3), BIDDER HEREBY CERTIFIES THAT THIS CERTIFICATE IS TRUE AND ACCURATE IN ALL RESPECTS; AND THAT IF A CONTRACT IS ISSUED TO BIDDER AND IF ANYTHING CONTAINED WITHIN THIS CERTIFICATE CHANGES DURING THE</p>						

SEE REVERSE SIDE FOR TERMS AND CONDITIONS

SIGNATURE	TELEPHONE	DATE
TITLE	FEIN	ADDRESS CHANGES TO BE NOTED ABOVE

WHEN RESPONDING TO RFQ, INSERT NAME AND ADDRESS IN SPACE ABOVE LABELED 'VENDOR'



State of West Virginia
 Department of Administration
 Purchasing Division
 2019 Washington Street East
 Post Office Box 50130
 Charleston, WV 25305-0130

Request for Quotation

RFQ NUMBER
707EC020

PAGE
7

ADDRESS CORRESPONDENCE TO ATTENTION OF
JOHN JOHNSTON
304-558-2402

VENDOR

*709014709 01 304-366-3075
ANDERSON EQUIPMENT COMPANY
7 RUSKIN DRIVE

FAIRMONT WV 26554

SHIP TO

DIVISION OF HIGHWAYS
EQUIPMENT DIVISION
ROUTE 33
BRUSHY FORK ROAD
BUCKHANNON, WV
26201 304-472-1750

DATE PRINTED 03/07/2007	TERMS OF SALE	SHIP VIA	F.O.B.	FREIGHT TERMS
BID OPENING DATE: 04/11/2007		BID OPENING TIME 01:30PM		

LINE	QUANTITY	UOP	CAT. NO.	ITEM NUMBER	UNIT PRICE	AMOUNT
<p>TERM OF THE CONTRACT, BIDDER WILL NOTIFY THE PURCHASING DIVISION IN WRITING IMMEDIATELY.</p> <p>BIDDER: <u>Anderson Equipment Company</u></p> <p>DATE: <u>May 8, 2007</u></p> <p>SIGNED: <u><i>Michael K. Burke</i></u> Michael K. Burke</p> <p>TITLE: <u>General Manager - WV</u></p> <p>* CHECK ANY COMBINATION OF PREFERENCE CONSIDERATION(S) IN EITHER "A" OR "B", OR BOTH "A" AND "B" WHICH YOU ARE ENTITLED TO RECEIVE. YOU MAY REQUEST UP TO THE MAXIMUM 5% PREFERENCE FOR BOTH "A" AND "B". (REV. 12/00)</p> <p>NOTICE</p> <p>A SIGNED BID MUST BE SUBMITTED TO:</p> <p>DEPARTMENT OF ADMINISTRATION PURCHASING DIVISION BUILDING 15 2019 WASHINGTON STREET, EAST CHARLESTON, WV 25305-0130</p> <p>THE BID SHOULD CONTAIN THIS INFORMATION ON THE FACE OF THE ENVELOPE OR THE BID MAY NOT BE CONSIDERED:</p>						

SEE REVERSE SIDE FOR TERMS AND CONDITIONS						
SIGNATURE				TELEPHONE		DATE
TITLE		FEIN		ADDRESS CHANGES TO BE NOTED ABOVE		

WHEN RESPONDING TO RFQ, INSERT NAME AND ADDRESS IN SPACE ABOVE LABELED 'VENDOR'



State of West Virginia
 Department of Administration
 Purchasing Division
 2019 Washington Street East
 Post Office Box 50130
 Charleston, WV 25305-0130

Request for Quotation

RFQ NUMBER
707EC020

PAGE
8

ADDRESS CORRESPONDENCE TO ATTENTION OF:
JOHN JOHNSTON 304-558-2402

VENDOR

*709014709 01 304-366-3075
 ANDERSON EQUIPMENT COMPANY
 7 RUSKIN DRIVE
 FAIRMONT WV 26554

SHIP TO

DIVISION OF HIGHWAYS
 EQUIPMENT DIVISION
 ROUTE 33
 BRUSHY FORK ROAD
 BUCKHANNON, WV
 26201 304-472-1750

DATE PRINTED	TERMS OF SALE	SHIP VIA	F.O.B.	FREIGHT TERMS
03/07/2007				

BID OPENING DATE: 04/11/2007 BID OPENING TIME 01:30PM

LINE	QUANTITY	UOP	CAT NO.	ITEM NUMBER	UNIT PRICE	AMOUNT
SEALED BID						
BUYER:				33		
RFQ. NO.:				707EC020		
BID OPENING DATE AND TIME						
PLEASE PROVIDE A FAX NUMBER IN CASE IT IS NECESSARY TO CONTACT YOU REGARDING YOUR BID:						
				304-756-2799		

CONTACT PERSON (PLEASE PRINT CLEARLY):				Brian Cantrell		

***** THIS IS THE END OF RFQ 707EC020 ***** TOTAL: _____						

SEE REVERSE SIDE FOR TERMS AND CONDITIONS

SIGNATURE	TELEPHONE	DATE
-----------	-----------	------

TITLE	FEIN	ADDRESS CHANGES TO BE NOTED ABOVE
-------	------	-----------------------------------

WHEN RESPONDING TO RFQ, INSERT NAME AND ADDRESS IN SPACE ABOVE LABELED 'VENDOR'

WEST VIRGINIA DEPARTMENT OF TRANSPORTATION
DIVISION OF HIGHWAYS
EQUIPMENT DIVISION

BIDDER'S EVALUATION REPORT

PROCUREMENT SPECIFICATIONS FOR OPEN END CONTRACT
NO. 351-2-F

SKID STEER LOADER WITH ATTACHMENTS

NOTE TO BIDDER: Procurement Specification No. 351-2-F, Paragraph 2.0 recommends the completion and submittal of this Report with your bid. Purpose of this Report is to enable the West Virginia Division of Highways Evaluation Committee to make full and fair evaluation of the bid. Addendums in order, along with exception sheets, should be with Bidder's Evaluation Report.

FAILURE TO SUBMIT THIS REPORT, COMPLETE IN ITS ENTIRETY, MAY SUBJECT THE BIDDER TO DISQUALIFICATION.

Reference Requisition No.: 707EC020

Bidder's Name: Anderson Equipment Company

Address: P. O. Box 3109 Charleston, WV 35331

Telephone Number: 304-756-2800

Years Bidder has been registered to do business with the State of West Virginia: 22 YRS.

Years Company has been an authorized dealer for proposed unit: 13 YRS.

X4.2 DELIVERY:

X4.2.1 Delivery date of completed representative unit: 45 Calendar Days After Date of
Five (5) within 45 days Purchase Agreement

X4.2.2 Delivery date of balance of completed units: 90-120 Calendar Days After Date of
Purchase Agreement

X5.0 AWARD CRITERIA;

X5.1 Price for loader only in quantities of

1-5	<u>26,037.00</u>	per unit
6-10	<u>26,037.00</u>	per unit
11 and over	<u>26,037.00</u>	per unit

Prices for loader and all attachments in quantities of

1-5	<u>312,338.98</u>	per unit
6-10	<u>312,338.98</u>	per unit
11 and over	<u>312,338.98</u>	per unit

X6.0 SPECIFICATIONS - GENERAL

X6.1 Manufacturer, model, series, and date of manufacture of proposed unit:

Gehl Model 5640E - 2007
Is descriptive literature, fully describing proposed unit attached to your bid? YES NO

If not, why? _____

X6.2 Will the required number of service manuals, and complete parts list be delivered to the Equipment Division at Buckhannon upon completion of delivery of total units? YES NO

Will the required Equipment Preventive Maintenance Form (Section X6.2 of Bidders Evaluation Report) be provided upon inspection of the pilot unit? YES NO

X6.2
2-10-00

EQUIPMENT PREVENTATIVE MAINTENANCE QUESTIONNAIRE

THIS FORM MUST BE COMPLETED IN ITS ENTIRETY BY SUCCESSFUL BIDDER OR MANUFACTURER'S TECHNICAL REPRESENTATIVE PRIOR TO DELIVERY OF PILOT MODEL TO THE WVDOH.

DESCRIPTION: _____ MAKE: _____

MODEL: _____ YEAR: _____ PURCHASE AMOUNT: _____

ENGINE: MAKE: _____ MODEL: _____ FUEL TYPE: _____

HORSEPOWER: _____ CYLINDER: _____ ENGINE SERIAL: _____

COOLING SYSTEM CAPACITY: _____

BELTS: DESCRIPTION: _____ PART NUMBERS: _____

GVW: _____ AXLE CAPACITY: FRONT: _____ REAR: _____

TIRES: FRONT MAKE & SIZE: _____

REAR MAKE & SIZE: _____

DIMENSIONS OF UNIT: LENGTH: _____ WIDTH: _____ LENGTH: _____

VENDOR CONTACT PERSON: _____ PHONE: _____

PARTS:

BATTERY MAKE: _____ MODEL: _____ CCA: _____

TOP OR SIDE POST: _____ DIMENSIONS: LENGTH _____ WIDTH _____ HEIGHT _____

SPARK PLUGS OR FUEL INJECTORS MAKE: _____ PART # _____

FUEL PUMP OR INJECTION PUMP MAKE: _____ MODEL: _____

ALTERNATOR MAKE: _____ PART #: _____

STARTER MAKE: _____ PART #: _____

TURBO CHARGER MAKE: _____ PART #: _____

TRANS. MAKE: _____ MODEL: _____ AUTO/MANUAL: _____

HYDRAULIC PUMP MAKE: _____ MODEL: _____

FILTERS MAKE PART NO. LUBRICANT MANUFACTURER TYPE

OIL _____

AIR INNER _____

AIR OUTER _____

FUEL PRIMARY _____

FUEL SECONDARY _____

COOLANT _____

HYDRAULIC _____

OTHER _____

ENGINE _____

TRANSMISSION _____

POWER STEERING _____

HYDRAULIC _____

DIFFERENTIALS _____

BRAKE FLUID _____

COOLANT _____

OTHER _____

X6.3 TRAINING:

Will training seminar be conducted on Preventive Maintenance, Operator and Mechanic Training
 YES NO

Will you conduct training with each purchase order against this open end contract?
 YES NO

Will training be conducted within 2 working days from the delivery of the pilot unit on the individual purchase order?
 YES NO

If NO, explain time frame _____

Will an Operator's Manual be furnished directly to Letha Lamb, Training Academy prior to the delivery of the pilot?
 YES NO

X6.4 If you are the successful vendor, will you furnish all training aids, i.e., videos, projectors, required in conducting the training?
 YES NO

X6.4.1 Will all manuals, booklets, etc. explaining preventive maintenance, operator procedures, and service schedule be delivered with each unit?
 YES NO
If NO, explain _____

X6.5 WARRANTY AND SERVICE POLICY

Will the warranty and service you provide comply with all areas as stated in Section 6.5 of specifications
 YES NO

Is warranty literature attached?
 YES NO

Is a minimum two (2) year bumper to bumper basic parts and labor warranty included for unit and attachments?
 YES NO

Describe:

____ See Warranty Statements - Attached _____

X6.5 WARRANTY AND SERVICE POLICY QUESTIONNAIRE

THIS FORM MUST BE COMPLETED IN ITS ENTIRETY BY THE SUCCESSFUL BIDDER OR MANUFACTURERS TECHNICAL REPRESENTATIVE PRIOR TO DELIVERY OF PILOT MODEL TO THE WVDOH (If additional lines are needed, make copies of form.)

1. Define the terms of the standard warranty. If not offered, so state. (Attach copy)
See warranty statements - attached

2. Define warranty service to be performed at DOH facilities and warranty service to be performed at manufacturer's representative facility. List name and location of manufacturer's representative.
All warranty work to be performed at vendors facility unless it is a machine down emergency.

Brian Cantrell - Fairmont

3. List locations for parts inventories that are within the State of West Virginia. Also, list availability levels, if known.

Charleston, WV

Fairmont, WV

12 additional branches at other locations.

4. During the term of warranty, list the guarantee discount to manufacturer's published list price for parts that bidder will sell the parts to owner.

- A. Terms: Net 30 Manufacturer's published list price less: n/a % discount
- B. Terms: Net 60 Manufacturer's published list price less: n/a % discount
- C. Terms: Net 90 Manufacturer's published list price less: n/a % discount

5. During the term of warranty, will all manufacturers or engineering improvements be submitted to Division of Highways? X YES NO

6. During the term of warranty, list the guaranteed rates charged for repair to the unit.

A. Shop Rate \$ n/a per mechanic hour

B. Travel Time Charge \$ n/a per mechanic hour
(Specify if one-way) n/a ; port to port n/a

C. Mileage Charge \$ n/a per vehicle mile
(Specify if one-way) n/a ; port to port n/a

D. Field Mechanic Rate \$ n/a per mechanic hour

E. Specify period of time that prices are in effect: n/a

F. Surcharge for miscellaneous items: n/a %

X6.6 EVALUATION COMMITTEE REQUIREMENTS

Is all component specifications, product literature, component models provided for Evaluation Committee bid determination? YES NO

X6.7 Will all parts, equipment, accessories, material, design and performance characteristics not specified herein, but which are necessary to provide a complete unit, be furnished with the unit and conform in strength, quality of material, and quality of workmanship to those which are advertised and provided to the market in general by the unit industry? YES NO

X6.7.1 Are all parts and accessories adequate and regularly supplied as standard to be included except those which may be duplications of specifications herein, and except these by specification are not to be furnished? YES NO

X6.7.2 Are all standard safety features that are required by Federal and State statutes of law included? YES NO

X7.0 SPECIFICATIONS OF THE QUOTED UNIT

The bidder should complete the following schedule in order for the Division to compare the actual bid unit to the specifications. Should the bidder except a requirement, then such exception may be only on the basis that such feature is not offered by the manufacturer. The Division will have the sole discretion as to whether the bidder's substitution meets the requirements of the specifications.

Manufacturer: Gehl Model: 5640E

Will the unit be completely assembled, adjusted with all equipment including standard and extra equipment installed and ready for continuous operation YES NO

Are all parts not specifically mentioned which are necessary for the unit to be complete and ready for operation or which are normally furnished as standard equipment be included? YES NO

X8.1 Operating weight of skid steer unit: 7380 lbs.

X8.2 Wheelbase: 42.5 inches

X8.3 Diesel Engine:

X8.3.1 Horsepower (Net): 82 HP

X8.3.2 Is engine pre-heat system provided YES NO

X8.3.3 Is manufacturer's recommended fuel filter with water separator provided? YES NO

Manufacturer: Gehl

- X8.3.4 Is unit equipped with automatic engine shutdown for low oil pressure and engine/hydraulic temperature YES NO
- X8.3.5 Dry type air filtration with primary and secondary elements YES NO
- X8.4 Hydraulic System:
- X8.4.1 Auxiliary hydraulics: 23 GPM
- X8.4.2 Does unit have high flow hydraulic system providing adequate flow and pressure for specified attachments YES NO
- X8.4.3 Filtration: 3 micron
- X8.4.4 Adequately sized hydraulic reservoir for the prime mover as well as any and all attachments YES NO
- Is gallons label and sight gauge included YES NO
- X8.4.5 Are hydraulic hoses cordova wrapped for operator protection YES NO
- X8.4.6 Are auxiliary front hydraulics with couplers provided with easy access with controls at operator station YES NO
- X8.5 Electrical System:
- X8.5.1 Manufacturers heavy duty 12 volt system YES NO Manufacturer: Gehl
- X8.5.2 Alternator: 95 amps
- X8.5.3 Battery manufacturers heavy duty maintenance free 12 volt YES NO CCA: 950
- X8.5.4 Work lights, dual front halogen; at least one rear halogen YES NO
- X8.6 Instrumentation: Audible and/or lighted warnings YES NO
- X8.6.1 Fuel level YES NO
- X8.6.2 Battery voltage YES NO
- X8.6.3 Engine coolant temperature YES NO
- X8.6.4 Transmission charge pressure YES NO
- X8.6.5 Hydraulic oil temperature YES NO
- X8.6.6 Engine oil pressure YES NO
- X8.6.7 Engine air cleaner restriction YES NO

- X8.6.8 Park brake reminder YES NO
- X8.6.9 Seat belt reminder YES NO
- X8.7 Tires:
- X8.7.1 Manufacturers standard pneumatic lug tires with 12 ply rating YES NO
 Manufacturer: Galaxy
- X8.8 Safety:
- X8.8.1 Backup alarm (OSHA approved) YES NO
- X8.8.2 Certified ROPS and FOPS YES NO
- X8.8.3 Parking brake manufacturers standard YES NO
- X8.8.4 All manufacturers safety related decals and safe operation recommendations affixed to each unit upon delivery YES NO
- X8.8.5 Rear view mirror YES NO
- X8.8.6 Equipped with rear window emergency escape YES NO
- X8.8.7 Low profile strobe light mounted for 360° visibility YES NO
 Manufacturer/Model: Gehl
- X8.8.8 Front and rear emergency flashers YES NO
- X8.8.9 Fire extinguisher bracket YES NO
- X8.9 Accessories:
- X8.9.1 Quick-Tatch 2 level attachment mounting design compatible with 90% of BobCat, New Holland, John Deere, and Case attachments YES NO
- X8.9.2 Rear counterweights provided to adequately balance unit with heaviest attachment mounted YES NO
- X8.9.3 Vinyl suspension seat with automotive type seat belt YES NO
- X8.9.4 Cab-all-weather enclosure with sliding side glasses YES NO
- X8.9.5 Front door with wiper, washer YES NO
- X8.9.6 Does unit have manufacturers heater/defroster/with air conditioner YES NO

X8.9.7 Is unit hydrostatic all wheel drive YES NO

X8.9.8 Integral belly plate YES NO

X8.10 Paint:

X8.10.1 Describe manufacturers recommended paint preparation and color: Unit is cleaned, degreased, primered, painted and then baked to finish.

X9.0 Attachments with attachment control kit:

X9.1 Are all attachments mounted on a quick-change mechanism YES NO

X9.2 Backhoe operation possible with the lift arms in the down position YES NO

X9.3 Is a remote attachment control device available for specified attachments (marked by an “**”) to start the loader and operate the attachment from the outside the operator control area YES NO

X9.4 Is a single control unit provided which will control all available attachments YES NO

X9.5 Attachments and pricing: SEE ATTACHED ATTACHMENT SECTION

X9.5.1 Angle Broom* _____

X9.5.2 Auger _____

X9.5.3 Backhoe _____

X9.5.4 Bale Fork _____

X9.5.5 Box Blade _____

X9.5.6 Box Blade with Laser Receiver* _____

X9.5.7 Breaker _____

X9.5.8 Brush Saw _____

X9.5.9 Brushcat Rotary Cutter _____

X9.5.10 Buckets:

X9.5.10.1 Construction 325 _____

X9.5.10.2 Construction 78 inch HD _____

X9.5.10.3 Construction 84 inch HD _____

X9.5.10.4 Foundry 72 inch _____

X9.5.10.5	Foundry 78 inch HD	_____
X9.5.10.6	Manure/Slurry 72 inch	_____
X9.5.10.7	Manure/Slurry 84 inch	_____
X9.5.10.8	Multi-Purpose 72 inch	_____
X9.5.10.9	Multi-Purpose 78 inch	_____
X9.5.10.10	Multi-Purpose 84 inch	_____
X9.5.10.11	Tooth 72 inch	_____
X9.5.10.12	Tooth 78 inch HD	_____
X9.5.10.13	Tooth 84 inch HD	_____
X9.5.10.14	Utility 72 inch	_____
X9.5.10.15	Utility 78 inch HD	_____
X9.5.10.16	Utility 84 inch HD	_____
X9.5.11	Chipper*	_____
X9.5.12	Combination Bucket	_____
X9.5.13	Concrete Mixer*	_____
X9.5.14	Concrete Pump	_____
X9.5.15	Digger	_____
X9.5.16	Dozer Blade	_____
X9.5.17	Drop Hammer	_____
X9.5.18	Dumping Hopper	_____
X9.5.19	Flail Cutter	_____
X9.5.20	Forks, Utility	_____
X9.5.21	Grader	_____
X9.5.22	Grapple, Industrial	_____
X9.5.23	Grapple, Root	_____

X9.5.24	Hydraulic Breaker	_____
X9.5.25	Landplane	_____
X9.5.26	Landscape Rake	_____
X9.5.27	Mower	_____
X9.5.28	Packer Wheel	_____
X9.5.29	Pallet Fork – Heavy Duty	_____
X9.5.30	Pallet Fork – Hydraulic	_____
X9.5.31	Planer:	
X9.5.31.1	Standard*	_____
X9.5.31.2	Curb*	_____
X9.5.31.3	High Flow*	_____
X9.5.32	Scarifier	_____
X9.5.33	Scraper	_____
X9.5.34	Seeder	_____
X9.5.35	Snowblade	_____
X9.5.36	Snow B-Blade*	_____
X9.5.37	Snowblower*	_____
X9.5.38	Sod Layer	_____
X9.5.39	Soil Conditioner:	
X9.5.39.1	Manual*	_____
X9.5.39.2	Hydraulic*	_____
X9.5.40	Spreader	_____
X9.5.41	Stabilizer	_____
X9.5.42	Stump Grinder*	_____
X9.5.43	Sweeper	_____
X9.5.44	Three-Point Hitch	_____
X9.5.45	Tiller	_____

- X9.5.46 Tracks, steel _____
- X9.5.47 Tree Spade* _____
- X9.5.48 Trench Compactor _____
- X9.5.49 Trencher _____
- X9.5.50 Utility Frame _____
- X9.5.51 Vibratory Roller _____
- X9.5.52 Water Kit _____
- X9.5.53 Wheel Saw _____
- X9.5.54 Whisker Broom _____

PRICING FOR ALL ATTACHMENTS _____

X10.0 Does the proposed unit meet or exceed the "OSHA of 1970" and/or subsequent changes?
 YES NO

X11.0 Does the unit conform to the advertising guidelines? (Describe)

Yes, no manufacturers or vendors decals will be visible unless they are in the manufacturing process. _____

X12.0 Preventive Maintenance and Operator's Training School:

X12.1 Will a preventative maintenance and operator's training seminar be provided?
 YES NO

If you are the successful vendor, will you furnish all training aids, i.e., videos, projectors, required in conducting the training?
 YES NO

Will all manuals, booklets, etc. preventive maintenance, operator procedures, and service schedule be delivered with each unit?
 YES NO
 If NO, explain _____



State of West Virginia
 Department of Administration
 Purchasing Division
 2019 Washington Street East
 Post Office Box 50130
 Charleston, WV 25305-0130

Request for Quotation

RFQ NUMBER
707EC020

PAGE
1

ADDRESS CORRESPONDENCE TO ATTENTION OF
JOHN JOHNSTON 304-558-2402

RFQ COPY
TYPE NAME/ADDRESS HERE

Anderson Equipment Company
 P. O. Box 3109
 Charleston, WV 25331

DIVISION OF HIGHWAYS
EQUIPMENT DIVISION
ROUTE 33
BRUSHY FORK ROAD
BUCKHANNON, WV
26201 **304-472-1750**

DATE PRINTED	TERMS OF SALE	SHIP VIA	F.O.B.	FREIGHT TERMS
04/02/2007				

BID OPENING DATE: **05/09/2007** **BID OPENING TIME 01:30PM**

LINE	QUANTITY	UOP	CAT NO	ITEM NUMBER	UNIT PRICE	AMOUNT
				ADDENDUM NO. 1		
				BID OPENING DATE AND TIME CHANGED		
				FROM: 04/11/07 AT 1:30 P.M.		
				TO: 05/09/07 AT 1:30 P.M.		
				ADDENDUM NO. 2 WILL BE ISSUED AT A LATER DATE WITH REVISED SPECIFICATIONS.		
				SIGN IN SHEET ATTACHED.		
				NO OTHER CHANGES.		
0001		EA		760-51		
	1			SKID STEER LOADER WITH ATTACHMENTS		
				***** THIS IS THE END OF RFQ 707EC020 ***** TOTAL:		

SEE REVERSE SIDE FOR TERMS AND CONDITIONS			
SIGNATURE	TELEPHONE	DATE	
TITLE	FEIN	ADDRESS CHANGES TO BE NOTED ABOVE	

WHEN RESPONDING TO RFQ, INSERT NAME AND ADDRESS IN SPACE ABOVE LABELED 'VENDOR'

**GENERAL TERMS & CONDITIONS
REQUEST FOR QUOTATION (RFQ) AND REQUEST FOR PROPOSAL (RFP)**

1. Awards will be made in the best interest of the State of West Virginia.
2. The State may accept or reject in part, or in whole, any bid.
3. All quotations are governed by the *West Virginia Code* and the *Legislative Rules* of the Purchasing Division.
4. Prior to any award, the apparent successful vendor must be properly registered with the Purchasing Division and have paid the required \$125.00 registration fee.
5. All services performed or goods delivered under State Purchase Orders/Contracts are to be continued for the term of the Purchase Order/Contract, contingent upon funds being appropriated by the Legislature or otherwise being made available. In the event funds are not appropriated or otherwise available for these services or goods, this Purchase Order/Contract becomes void and of no effect after June 30.
6. Payment may only be made after the delivery and acceptance of goods or services.
7. Interest may be paid for late payment in accordance with the *West Virginia Code*.
8. Vendor preference will be granted upon written request in accordance with the *West Virginia Code*.
9. The State of West Virginia is exempt from federal and state taxes and will not pay or reimburse such taxes.
10. The Director of Purchasing may cancel any Purchase Order/Contract upon 30 days written notice to the seller.
11. The laws of the State of West Virginia and the *Legislative Rules* of the Purchasing Division shall govern all rights and duties under the Contract, including without limitation the validity of this Purchase Order/Contract.
12. Any reference to automatic renewal is hereby deleted. The Contract may be renewed only upon mutual written agreement of the parties.
13. **BANKRUPTCY:** In the event the vendor/contractor files for bankruptcy protection, this contract is automatically null and void, and is terminated without further order.
14. **HIPAA Business Associate Addendum** - The West Virginia State Government HIPAA Business Associate Addendum (BAA), approved by the Attorney General, and available online at the Purchasing Division's web site (<http://www.state.wv.us/admin/purchase/vrc/hipaa.htm>) is hereby made part of the agreement. Provided that, the Agency meets the definition of a Covered Entity (45 CFR §160.103) and will be disclosing Protected Health Information (45 CFR §160.103) to the vendor.

INSTRUCTIONS TO BIDDERS

1. Use the quotation forms provided by the Purchasing Division.
2. **SPECIFICATIONS:** Items offered must be in compliance with the specifications. Any deviation from the specifications must be clearly indicated by the bidder. Alternates offered by the bidder as **EQUAL** to the specifications must be clearly defined. A bidder offering an alternate should attach complete specifications and literature to the bid. The Purchasing Division may waive minor deviations to specifications.
3. Complete all sections of the quotation form.
4. Unit prices shall prevail in cases of discrepancy.
5. All quotations are considered F.O.B. destination unless alternate shipping terms are clearly identified in the quotation.
6. **BID SUBMISSION:** All quotations must be delivered by the bidder to the office listed below prior to the date and time of the bid opening. Failure of the bidder to deliver the quotations on time will result in bid disqualifications.

SIGNED BID TO:

Department of Administration
Purchasing Division
2019 Washington Street East
Post Office Box 50130
Charleston, WV 25305-0130

SIGN IN SHEET

RFQ # 707EC0210
Date: 3-29-07

- | Firm & Representative Name: | Mailing Address: | Phone, Fax, & E-Mail: |
|---|---|---|
| 1. <u>Rish Equipment</u>
<u>Cathy Estep</u> | <u>Row 7 35 St. Albans</u>
<u>WV 25177</u> | P <u>304-755-3311</u> ⁶⁸²⁸
F <u>304-755-3603</u>
E-mail _____ |
| 2. <u>Walker Machinery</u>
<u>Eric Craney</u> | <u>3 Park Rd HUBS Ind. Park</u>
<u>Niara WV 25143</u> | P <u>304-389-4196</u>
F <u>304-759-6404</u>
E-mail <u>ecraney@walker-cat.</u> |
| 3. <u>WV TRACTOR</u>
<u>GARY GRADY</u> | <u>P.O. Box 473</u>
<u>CHARLESTON WV</u>
<u>25322</u> | P <u>346-5301</u>
F <u>346-5305</u>
E-mail <u>wvtractor@msn.com</u> |
| 4. <u>GENE Fisher</u>
<u>Fairplain Tractor Sale</u> | <u>PO-Box 287</u>
<u>Ripley W.Va.</u>
<u>25271</u> | P <u>304-372-9825</u>
F <u>304-372-2713</u>
E-mail _____ |
| 5. <u>Robert Skelton</u>
<u>Reckant Equipment Co</u> | <u>MTNeb0</u>
<u>W.V.</u>
<u>P.O. Box 488</u> | P <u>304-872-4055</u>
F <u>304-872-7288</u>
E-mail <u>Neb0@Reckant.Com</u> |

Please print or write legibly!

Your fax # is essential to contact you timely!

SIGN IN SHEET

RFQ # 707EC020

Date: 3-29-07

Firm & Representative Name:

Mailing Address:

Phone, Fax, & E-Mail:

1. ✓ Bobcat of Advantage Valley PO Box 7555 P 776-9100
Steve Lewis Cross Lanes Wv 25356 F 776-0285
 E-mail Steve.Lewis@jaffco.com

2. Rudd Equipment PO Box 610 P 755-7288
Vic Green Nitro, WVa. 25143 F 755-7990
 E-mail Vgreen@ruddequipment.com

3. Unscouters Ind, EQ. 100 College Ave. P 724-433-1578
Mike Clower Lewistown, PA F - - 2098
 E-mail _____

4. Brian Cantrell 7 Ruskin Dr. P 304-366-3075
Anderson Equip. Co. Fairmont, WV 26554 F 304-366-7214
 E-mail _____

5. Cecil Horne P.O. Box 7 P 304-755-3371
Leslie Equipment Co. Nitro, W.V. 25143 F 304-755-3256
 E-mail horne.cecil@LECI.com

Please print or write legibly!

Your fax # is essential to contact you timely!

SIGN IN SHEET

RFQ # _____

Date: _____

Firm & Representative Name:

Mailing Address:

Phone, Fax, & E-Mail:

1. Greg Shambler
Leslie EquipP.O. Box 7
N. Gro 25147P 304-542-433
F 755-3254E-mail Shamblergregory@
lecl.com2. M. Lee Burks
Anderson Equip CompanyBox 3109
Charleston, 25337P 304-756-2800
F 304-756-2777E-mail mburks@andersonequi
co.3. Anderson Equipment
Teri SurfaceP.O. Box 3109
Chas., WV 25331P 304-756-2800
F 304-756-2799E-mail tsurface@andersonequi
com4. Jim Bayers
Middletown Tractor2032 Farmant ave
Farmant, WV 26554P 304-366-4690
F 304-366-4698E-mail Jim@middletowntractor, ce5. Sarah Rexroad
Nettles Equip.HC71 Box 490
Duck WV 25063P 364-2445
F 364-8360E-mail Sarahrexroad@
harvestmail.net

Please print or write legibly!

Your fax # is essential to contact you timely!

SIGN IN SHEET

RFQ # _____

Date: _____

Firm & Representative Name:

Mailing Address:

Phone, Fax, & E-Mail:

1. State Equipment
Jason Lamar

560 Griffith Rd
Cross Lanes WV 25317

P 304-776-4405
F 304-776-4409

E-mail jason1@stateequipment.com

2. WALKER MACHINERY
WALTER CLARK

3 Park Rd
Charleston, WV

P 304-759-6400
F 304-552-6487

E-mail _____

3. _____

P _____
F _____

E-mail _____

4. _____

P _____
F _____

E-mail _____

5. _____

P _____
F _____

E-mail _____

Please print or write legibly!

Your fax # is essential to contact you timely!



State of West Virginia
 Department of Administration
 Purchasing Division
 2019 Washington Street East
 Post Office Box 50130
 Charleston, WV 25305-0130

Request for Quotation

RFQ NUMBER:
707EC020

PAGE:
1

ADDRESS CORRESPONDENCE TO ATTENTION OF:
**JOHN JOHNSTON
 304-558-2402**

**RFQ COPY
 TYPE NAME/ADDRESS HERE**

VENDOR

Anderson Equipment Company
 P. O. Box 3109
 Charleston, WV 25331

SHIP TO

DIVISION OF HIGHWAYS
 EQUIPMENT DIVISION
 ROUTE 33
 BRUSHY FORK ROAD
 BUCKHANNON, WV
 26201 304-472-1750

DATE PRINTED	TERMS OF SALE	SHIP VIA	F.O.B.	FREIGHT TERMS
04/04/2007				

BID OPENING DATE: **05/09/2007** BID OPENING TIME **01:30PM**

LINE	QUANTITY	UOP	CAT NO.	ITEM NUMBER	UNIT PRICE	AMOUNT
ADDENDUM NO. 2						
CHANGES TO THE SPECIFICATIONS PER THE ATTACHED.						
BID OPENING DATE AND TIME REMAINS THE SAME.						
NO OTHER CHANGES.						
0001	1	EA		760-51		
SKID STEER LOADER WITH ATTACHMENTS						
***** THIS IS THE END OF RFQ 707EC020 ***** TOTAL:						

SEE REVERSE SIDE FOR TERMS AND CONDITIONS

SIGNATURE	TELEPHONE	DATE
TITLE	FEIN	ADDRESS CHANGES TO BE NOTED ABOVE

WHEN RESPONDING TO RFQ, INSERT NAME AND ADDRESS IN SPACE ABOVE LABELED 'VENDOR'

**GENERAL TERMS & CONDITIONS
REQUEST FOR QUOTATION (RFQ) AND REQUEST FOR PROPOSAL (RFP)**

1. Awards will be made in the best interest of the State of West Virginia.
2. The State may accept or reject in part, or in whole, any bid.
3. All quotations are governed by the *West Virginia Code* and the *Legislative Rules* of the Purchasing Division.
4. Prior to any award, the apparent successful vendor must be properly registered with the Purchasing Division and have paid the required \$125.00 registration fee.
5. All services performed or goods delivered under State Purchase Orders/Contracts are to be continued for the term of the Purchase Order/Contract, contingent upon funds being appropriated by the Legislature or otherwise being made available. In the event funds are not appropriated or otherwise available for these services or goods, this Purchase Order/Contract becomes void and of no effect after June 30.
6. Payment may only be made after the delivery and acceptance of goods or services.
7. Interest may be paid for late payment in accordance with the *West Virginia Code*.
8. Vendor preference will be granted upon written request in accordance with the *West Virginia Code*.
9. The State of West Virginia is exempt from federal and state taxes and will not pay or reimburse such taxes.
10. The Director of Purchasing may cancel any Purchase Order/Contract upon 30 days written notice to the seller.
11. The laws of the State of West Virginia and the *Legislative Rules* of the Purchasing Division shall govern all rights and duties under the Contract, including without limitation the validity of this Purchase Order/Contract.
12. Any reference to automatic renewal is hereby deleted. The Contract may be renewed only upon mutual written agreement of the parties.
13. **BANKRUPTCY:** In the event the vendor/contractor files for bankruptcy protection, this contract is automatically null and void, and is terminated without further order.
14. **HIPAA Business Associate Addendum** - The West Virginia State Government HIPAA Business Associate Addendum (BAA), approved by the Attorney General, and available online at the Purchasing Division's web site (<http://www.state.wv.us/admin/purchase/vrc/hipaa.htm>) is hereby made part of the agreement. Provided that, the Agency meets the definition of a Covered Entity (45 CFR §160.103) and will be disclosing Protected Health Information (45 CFR §160.103) to the vendor.

INSTRUCTIONS TO BIDDERS

1. Use the quotation forms provided by the Purchasing Division.
2. **SPECIFICATIONS:** Items offered must be in compliance with the specifications. Any deviation from the specifications must be clearly indicated by the bidder. Alternates offered by the bidder as **EQUAL** to the specifications must be clearly defined. A bidder offering an alternate should attach complete specifications and literature to the bid. The Purchasing Division may waive minor deviations to specifications.
3. Complete all sections of the quotation form.
4. Unit prices shall prevail in cases of discrepancy.
5. All quotations are considered F.O.B. destination unless alternate shipping terms are clearly identified in the quotation.
6. **BID SUBMISSION:** All quotations must be delivered by the bidder to the office listed below prior to the date and time of the bid opening. Failure of the bidder to deliver the quotations on time will result in bid disqualifications.

SIGNED BID TO:

Department of Administration
Purchasing Division
2019 Washington Street East
Post Office Box 50130
Charleston, WV 25305-0130

ADDENDUM #2
707EC020

OPEN END CONTRACT

SKID STEER LOADER WITH ATTACHMENTS

CHANGES TO SPECIFICATIONS:

FROM:

5.1 SECOND PARAGRAPH

Prices for the units with attachments shall be in quantities of 1-5, 6-10, and 11 and over. However, for evaluation purposes, we will use quantities 1-5 for loader and all attachments. DOH reserves the right to place orders in any quantity. Orders placed may be with one (1) or all attachments. Attachments may be ordered as needed.

TO:

5.1 SECOND PARAGRAPH

Prices for the units with attachments shall be in quantities of 1-5, 6-10, and 11 and over. Also, price for loader only shall be submitted as well. However, for evaluation purposes, we will use quantities 1-5 for loader and all attachments. DOH reserves the right to place multiple orders in any quantity. Orders placed may be with one (1) or all attachments. Attachments may be ordered as needed.

FROM:

8.4.2 Unit shall have high flow hydraulic system providing adequate flow and pressure for specified attachments.

TO:

8.4.2 Unit shall have high flow hydraulic system (30 GPM minimum).

DELETE:

9.3 A remote attachment control device should be available for specified attachments (marked by an “**”) to start the loader and operate the attachment from the outside the operator control area.

RENUMBER:

9.4
to A single control unit should be provided which will control all available attachments.
9.3

DELETE AS WRITTEN:

9.5 The following attachments should be available:
and
sub
topics
9.5.1
to and
including
9.5.54

ADD:

9.4 The following attachments shall be available and must be priced to award contract.

and
sub
topics
9.4.1
through
9.4.32
as follows:

**AUGER – WOODS
EQUIPMENT
CORPORATION OR
EQUAL**

HA 25

HA30

Drive Type

Planetary

Planetary

Flow Range

10 – 30 gpm

10 – 40 gpm

Pressure Range

3500 psi

3500 psi

Maximum Bit Size

36"

36"

Approximate Weight

620 lb.

650 lb.

Performance Guide

Heavy Duty

Heavy Duty

**BIT SPECIFICATIONS
FOR BOTH MODELS**

**Bit Specification – Hex –
Single Flight Extension**

6" x 50" Head

12" x 50" Head

24" x 50" Head

Single Flight Extension

12" extension

24" extension

48" extension

BACKHOE WITH 12 INCH BUCKET- ATTACHMENT TECHNOLOGIES INC. OR EQUAL	509	511	609	611
Transport Height	7 ft. 9 in.	8 ft. 10 in	7 ft. 9 in	8 ft. 10 in
Transport Width	5 ft. 0 in	5 ft. 0 in	4 ft. 9 in.	4 ft. 9 in
Ground Clearance	11 ft	11 ft	11 ft	11 ft
Overall Length	7 ft. 7 in	7 ft 9 in	7 ft 7 in	7 ft 9 in
Boom Pivot Height	16 in.	16 in.	16 in.	16 in.
Operating Weight w/12 in. Bucket	1425 lb.	1594 lb.	1702 lb.	1847 lb.
Digging Depth Maximum	9 ft. 8 in.	11 ft. 1 in.	9 ft. 8 in	11 ft. 1 in.
Digging Depth (2 ft.) Flat Bottom	9 ft. 7 in.	11 ft. 0 in.	9 ft. 7 in.	11 ft. 0 in.
Digging Depth (8 ft.) Flat Bottom	8 ft. 3 in.	9 ft. 11 in	8 ft. 3 in.	9 ft. 11 in
Overall Operating Height – Fully Raised	12 ft 10 in	14 ft. 5 in	12 ft. 10 in	14 ft. 5 in
Loading Height	6 ft. 10 in	8 ft 0 in	6 ft. 10 in	8 ft. 0 in
Loading Reach	4 ft. 2 in.	5 ft 0 in	4 ft. 2 in	5 ft. 0 in
Reach from Swing Post	12 ft. 9 in	14 ft. 5 in	12 ft. 10 in	14 ft. 5 in
Bucket Rotation	180 degrees	180 degrees	180 degrees	180 degrees
Swing Arc	180 degrees	180 degrees	180 degrees	180 degrees
Straight Wall Digging Depth	7 ft. 3 in	8 ft. 2 in	7 ft. 3 in	8 ft. 2 in
Stabilizer Spread	7 ft. 11 in.	7 ft 11 in	9 ft. 11 in	9 ft. 11 in
Operating Position Stabilizer Down Below Grade	16 in	16 in	17 in	17 in
System Relief Valve Setting	2500 psi	2500 psi	2500 psi	2500 psi
Digging Force – Bucket Cylinder	5676 lb.	5676 lb.	5908 lb.	6167 lb.
Digging Force – Dipper Cylinder	2754 lb.	3056 lb.	3232 lb	4160 lb.

BACKHOE – MINI – FFC ATTACHMENTS OR EQUAL	MB 12	MB 18	MB 24
Digging Depth	5 ft. 6 in	5 ft. 6 in	5 ft. 6 in
Bucket Width	12 in	18 in	24 in
Weight	635 lb.	665 lb	695 lb.

BLADE – DOZER – ATTACHMENT TECHNOLOGIES INC. OR EQUAL	DB 96
Width from Centerline to Inside Edge @ 15 degree Angle	49.31 in
Width from Centerline to Inside Edge @ 30 degree Angle	47.38 in
Dozer Blade Width @15 degree Angle	92.73 in.
Dozer Blade Width @ 30 degree Angle	83.56 in
Width from Centerline to Outside Edge @ 15 degree Angle	43.41 in.
Width from Centerline to Outside Edge @ 30 degree Angle	36.16 in.
Overall Width	96.00 in
Angle Left and Right	30 degrees
Overall Length	36.68 in
Overall Height	29.89 in.
Approximate Weight	1460 lb.

BOOM – MATERIAL HANDLING – ATTACHMENT TECHNOLOGIES INC. OR EQUAL	MH 66
Rated Load Capacity	1500 lb.
Height	66 in.

BREAKER – HYDRAULIC – KOMATSU OR EQUAL	JPB 210
CIMA Tool Energy Rating	212 ft. lb.
Flow Range	22 gpm
Striking Rate	1375 bpm
Operating Pressure	2059 psi
Working Weight	527 lb.
Striking Rate (blows per minute)	1040 min
Adjusted Breaker Pressure	2000 psi
Max. Operating Pressure	2100 psi
Tool Diameter	2.5 in.

BROOM – ANGLE – POLY/WIRE BRISTLES – ATTACHMENT TECHNOLOGIES INC. OR EQUAL	AB 84
Overall Width	94 in.
Sweeping Width	88 in
Overall Height	35.5 in.
Length Coupler to Brush Front	59.60 in.
Transport Height On Stand	40.0 in.
Maximum Angle (Left and Right)	30 degrees
Sweeping Width @ 30 degree Angle	76 in.
Weight	1031 lb.
Brush Diameter	32 in.
Wafers (Quantity)	45
Optional Water Kit with 25 Gallon Tank Manual/Hydraulic Angle	

BROOM – GENERAL PURPOSE PICK- UP – WOODS EQUIPMENT CORP. OR EQUAL	PB68
Brush Width	60 in.
Overall Width	68.5 in
Height	25.25 in
Length	67.7 in
Approximate Weight	714 lb.
Hopper Capacity	13.5 cu. ft
Optional Gutter Broom	Cleaning next to curbs

BRUSH CUTTER – FFC ATTACHMENTS	LAF 3772
OR EQUAL	
Overall Width	75.5 in
Cutting Width	72 in
Height	27 in
GPM Range	15-30 gpm
Max PSI Range	3500 psi
Blade Speed Min/Max	12474/19127 ft/min
Weight Approximate	1653 lb.

BUCKET – BRUSH GRAPPLE –	BG 84
ATTACHMENT TECHNOLOGIES INC.	
OR EQUAL	
Overall Width	84 in
Overall Depth	35.9 in
Grapple Width	20.5 in
Tine Spacing	6 in.
Grapple Height – Closed	26.4 in.
Grapple Hook – Opening	42 in.
Overall Weight (lbs)	826 lb.
Clamping Force (lbs)	1250 lb.
Number of Grapple Teeth	4
Number of Cylinders	2
Tines & End Plates	1/2 in. T1 steel (100,000 lb. yield)
Bore	2.00 in
Stroke	8.25 in
Rod Diameter	1.25 in.

BUCKET – FORKED SCRAP GRAPPLE – FFC ATTACHMENTS OR EQUAL	FSG 63	FSG 72
Opening Height	41 in.	41 in.
Height Closed	20 in.	20 in.
Usable Tooth	24.13 in.	24.13 in.
Width	63.44 in.	73.06 in.
Number of Teeth	8	10
Approximate Weight	990 lb.	1100 lb.
Cylinder Bore	2 in.	2 in.
Cylinder Stroke	8 in.	8 in.

BUCKET – GENERAL PURPOSE – WOODS EQUIPMENT CORP. OR EQUAL	GP 68S	GP 73S	GP 68L	GP 73L
Type of Bottom	Short	Short	Long	Long
Width	68 in	73 in	68 in	73 in
Height	19 in	19 in	19 in	19 in
Length	29 in	29 in	35 in	35 in
Approximate Weight	440 lb.	469 lb.	475 lb.	508 lb.
Heaped Capacity	13.4 cu ft	14.4 cu ft	16.5 cu ft	17.8 cu ft
Optional Teeth	Weld on	Weld on	Weld on	Weld on
Optional Bolt on Cutting Edge	5/8 in x 8 in reversible	5/8 in x 8 in reversible	5/8 in x 8 in reversible	5/8 in x 8 in reversible
Optional Bolt on Toothbar	66 3/8 in – 66 3/4 in	71 3/8 in – 71 3/4 in	66 3/8 in – 66 3/4 in	71 3/8 in – 71 3/4 in
Inside Bucket Width				

BUCKETS – GENERAL PURPOSE UTILITY & LIGHT MATERIAL – WOODS EQUIPMENT CORPORATION OR EQUAL	UT 72	LM 72	LM 78	LM 84
Type	GPU	LM	LM	LM
Width	72 in	72 in	78 in	84 in
Height	25 in	26 in	26 in	26 in
Length	35 in	38 in	38 in	38 in
Approximate Weight	553 lb.	585 lb.	617 lb.	660 lb.
Heaped Capacity	22.8 cu. ft	25.8 cu ft	28.1 cu ft	30.3 cu ft
Optional Bolt on Cutting Edge	5/8 in x 8 in reversible	5/8 in x 8 in reversible	5/8 in x 8 in reversible	5/8 in x 8 in reversible
Optional Bolt on Toothbar Inside Bucket Width	70 3/8 in – 70 3/4 in	NA	NA	NA

BUCKET – HEAVY DUTY SCRAP GRAPPLE – WOODS EQUIPMENT CORP. OR EQUAL	SG 72	SG 78
Width	72 in	78 in
Height	28 in	28 in
Length	27 1/4 in	27 1/4 in
Capacity	14 cu ft	15.2 cu ft
Approximate Weight	856 lb.	886 lb.
Cylinder Bore Diameter	2 in.	2 in.
Cylinder Stroke	8 1/4 in	8 1/4 in
Optional Bolt on Cutting Edge	5/8 in x 8 in reversible	5/8 in x 8 in reversible

**BUCKET – MULTI-
PURPOSE – WOODS
EQUIPMENT CORP. OR
EQUAL**

MP 73

MP 78

Width	73 in	78 in
Height	31 in	31 in
Length	33 in	33 in
Heaped Capacity	14.2 cu ft	15.5 cu ft
Approximate Weight	644 lb.	688 lb.
Cylinder Rod Diameter	1 1/2 in	1 1/2 in
Cylinder Bore	2 1/2 in	2 1/2 in
Cylinder Stroke	8 in	8 in
Optional Bolt on Reversible Cutting Edge	5/8 in x 8 in reversible	5/8 in x 8 in reversible
Optional Bolt on Toothbar	71 3/8 in –	76 3/8 in –
Inside Bucket Width	71 3/4 in	76 3/4 in

**BUCKET – ROCK – ATTACHMENT
TECHNOLOGIES INC. OR EQUAL**

RB 75

Overall Width	74.35 in
Overall Depth	42.45 in
Depth with Skid Steer Mounting	49.80 in
Overall Height	21.77 in
Tine Spacing (Center to Center)	4.25 in
Tine Spacing (Between Tines)	3.125 in
Overall Weight (lbs.)	619 lb.
Number of Tines	18
Tine Rod Diameter	1.125 in

COLD PLANER – WOODS EQUIPMENT CORP. OR EQUAL	CP 12	CP 16	CP 18	CP 24	CP 30
Depth of Cut	0-6 in	0-6 in	0-6 in	0-6 in	0-6 in
Width of Cut	12 in	16 in	18 in	24 in	30 in
Number of Teeth	28	50	56	70	77
Sideshift	22 in	22 in	22 in	22 in	22 in
Tilt	19 degrees	19 degrees	19 degrees	15 degrees	11 degrees
Weight	1200 lb.	1750 lb	2000 lb.	2300 lb.	2450 lb
Hydraulic Depth Control	Std	Std	Std	Std	Std
Hydraulic Tilt Control	Std	Std	Std	Std	Std

CONCRETE CLAW – FFC ATTACHMENTS OR EQUAL	10024
Working Width	24 in
Working Depth	48 in
Height OD	21 in
Rear Opening Height	7.5 in
Weight Approximate	575 lb.

FORKS – PALLET – ATTACHMENT TECHNOLGIES INC OR EQUAL	PF 48
Weight (Including mounting)	370 lb.
Fork Length	48 in
Fork Capacity	4000 lb.
Fork Spread Range	4 3/8 – 40 3/8 in
High Visibility Back Guard	Yes
Tooth Double Lock Downs	Yes

GRAPPLE – LOG FORK – FFC ATTACHMENTS OR EQUAL	LG 28
Tine Length	28.4 in
Opening Height	43.1 in
Capacity	6400 lb.
Weight	610 lb.

HITCH – THREE POINT – WOODS EQUIPMENT CORP. OR EQUAL	TH3000
Overall Width	46 in
Height	26 in
Length	11 in
Approximate Weight	180 lb.

POWER RAKE – FFC ATTACHMENTS OR EQUAL	PRA 90
Working Width	90 in
Overall Width	101 in
Fully Angled Width	86 in
Height	30.3 in
Angle Option	Manual Hydraulic
Weight	1075 lb.

PREPARATOR – FFC ATTACHMENTS OR EQUAL	P 76
Bucket Capacity	12.5 cu ft
Overall width	85.25 in
Bucket Swath Width	76 in
Overall Bucket Height	25.53 in
Overall Bucket Length	53 in
RPM-r/min@16 gpm Nominal Flow	0-100
Overall Drum Diameter	21.5 in
Tooth Thickness	.19 in
Tooth Length	2.19 in
Number of Teeth	340
Rake Drive	#80H Roller Chain
Brush Drive	#50H Roller Chain
Overall Weight	1465 lb.

ROCK WHEEL WITH 50 GALLON WATER KIT – WOODS EQUIPMENT CORP. OR EQUAL	RW 12	RW 18	RW 24
Depth of Cut	0-12 in	0-18 in	0-24 in
Width of Cut	2.5/4.5 in	2.5/4.5 in	2.5/4.5 in
Number of Teeth	28/33	42/44	56/66
Side Shift	22 in	22 in	22 in
Weight	1600 lb.	1800 lb.	2100 l.b
Wheel Speed	60 rpm	60 rpm	60 rpm
Cutting Speed	Up to 15 fpm	Up to 15 fpm	Up to 15 fpm

**ROLLER – VIBRATORY – VR 66A
WOODS EQUIPMENT
CORP. OR EQUAL**

Drum Width	66 in
Overall Width	73 in
Drum Oscillation	+/-50 degrees
Overall Height	27 in
Overall length	33 in
Drum Diameter	24 in
Total Output	8740 lb.
Frequency VPM	2000 @ 15 gpm
Weight lbs. Smooth	1633 lb.
Weight lbs. Padded	1850 lb.

VR 73A

73 in
80.5 in
+/-15 degrees
27 in
33 in
24 in
10,240 lb.
2000 @ 15 gpm
1762 lb
2100 lb.

**SCARIFIER – WOODS EQUIPMENT SF 3000
CORP. OR EQUAL**

Working Width	40 in
Overall Width	63 in
Height	27 in
Length	20 in
Approximate Weight	350 lb.
Number of Shanks	5

**SNOW BLADE – FFC ATTACHMENTS SB 96
OR EQUAL**

Length	96 in
Height with Edge	23.25 in
Angled Width	82.9 in
Weight	525 lb.

SNOW BLOWER – FFC ATTACHMENTS OR EQUAL	84	84H
Cutting Width	84 in	84 in
Shroud Opening	25 in	36 in
Overall Depth	38 in	43 in
Overall Height	56.75 in	74 in
Weight	720 lb.	1230 lb.

STUMP GRINDER – WOODS EQUIPMENT CORP. OR EQUAL	SG 20	SG 40	SG 60
Overall Length	64.1 in	64.1 in	64.1 in
Telescopic Extension	7 in	7 in	7 in
Horsepower Delivered	To 20 HP	To 40 HP	To 60 HP
Cutting Height Above Ground	21 in	21 in	21 in
Cutting Depth Below Ground	16 in	16 in	16 in
Cutting Wheel Width	3.25 in	3.25 in	3.25 in
Cutting Width Swing Range	60 in 140 degrees	60 in 140 degrees	60 in 140 degrees
Type of Teeth	0.5 in slanted, carbide tip	0.5 in slanted, carbide tip	0.5 in slanted, carbide tip
Number of Teeth	32	32	32
Wheel Diameter	18 in	18 in	18 in
Wheel Speed (Approx	700 rpm	900 rpm	900 rpm
Weight	765 lb.	775 lb.	840 lb.

TILLER – WOODS EQUIPMENT CORP. OR EQUAL	TL 73	TL 84
Overall Width	86 in	97 in
Cutting Width	73 in	84 in
Working Depth	6 in	6 in
Overall Height	31 in	31 in
Number of Tines	36	40
Tine Rotation	Bi-directional	Bi-directional
Weight	1050 lb.	1228 lb.
Driveline	(2) in-line gerotor motors	(2) in-line gerotor motors
Maximum Tine Speed	121 rpm	121 rpm
Max Flow	25 gpm @ 2000 psi	46 gpm @ 3500 psi

TREE SPADE – FFC ATTACHMENTS OR EQUAL	TS36	TS40	TS42	TS44	TS48
Maximum Ball Size	36 in	40 in	42 in	44 in	48 in
Weight	258 lb.	312 lb.	360 lb.	378 lb.	425 lb./

TRENCHER – ATTACHMENT TECHNOLOGIES INC. OR EQUAL	615	625	650C
Boom Size	36 in	48 in	48 in
Trench Depth @ Recommended Angle	36 in	48 in	48 in
Chain Width Recommended Trenching Angle	6 in 65 degrees	6 in 65 degrees	6 in 65 degrees
Length	65 in	86 in	84 in
Width	42 in/50.5 in	53 in	43 in
Height	28 in	32 in	37 in
Spoil Discharge Reach	24 in	18 in	27 in
Weight	495 lb/775 lb	N/A	N/A

ADDENDUM #2
707EC020

OPEN END CONTRACT

SKID STEER LOADER WITH ATTACHMENTS

CHANGES TO BIDDER'S EVALUATION REPORT:

X5.1 NO CHANGE REQUIRED

Price for loader only in quantities of	1-5	26,037.00	per unit
	6-10	26,037.00	per unit
	11 and over	26,037.00	per unit

Prices for loader and all attachments In quantities of	1-5	312,338.98	per unit
	6-10	312,338.98	per unit
	11 and over	312,338.98	per unit

FROM:

X8.4.2 Does unit have high flow hydraulic system providing adequate flow and pressure for specified attachments YES NO

TO:

X8.4.2 Does unit have high flow hydraulic system YES NO

GPM: 36

DELETE:

X9.3 Is a remote attachment control device available for specified attachments (marked by an “*”) to start the loader and operate the attachment from the outside the operator control area _____ YES _____ NO

RENUMBER:

X9.4
To Is a single control unit provided which will control all available attachments
X9.3 _____X_____ YES _____ NO

DELETE AS WRITTEN:

X9.5
And Attachments and pricing:
Sub
Topics
9.5.1
To and
Including
9.5.54

ADD:

X9.4
And Are you supplying all attachments as listed in the specifications?
Sub _____X_____ YES _____ NO
Topics
9.4.1
Through
9.4.32
As follows:

X9.4 ATTACHMENTS:

X9.4.1 Does the **AUGER** you are providing meet or exceed the specification?
 YES NO

Manufacturer: Lowe

	MODEL: SK225H	MODEL: SK250H
Auger	\$1,690.25	\$2,719.92
BITS – HEX:		
6" X 50" Head	\$199.44	\$199.44
12" x 50" Head	\$360.43	\$360.43
24" x 50" Head	\$513.18	\$513.18
SINGLE FLIGHT EXTENSIONS:		
12" Extension	\$122.31	\$122.31
24" Extension	\$136.90	\$136.90
48" Extension	\$201.92	\$201.92

TOTAL PRICE: \$ 3,224.43 \$ 4,254.10

X9.4.2 Does the **BACKHOE WITH 12 INCH BUCKET** you are providing meet or exceed the specification?
 YES NO

Manufacturer: Bradco

	MODEL: 509	MODEL: 511	MODEL: 609	MODEL: 611
Bucket with 12 Inch Bucket	\$7,216.99	\$7,599.00	\$7,742.54	\$8,192.73

TOTAL PRICE: \$7,216.99 \$7,599.00 \$7,742.54 \$8,192.73

X9.4.3 Does the **BACKHOE-MINI** you are providing meet or exceed specifications?
 YES NO

Manufacturer: Paladin

	MODEL: MB12	MODEL: MB18	MODEL: MB24
Backhoe – Mini	\$1,631.22	\$1,700.40	\$1,766.20
TOTAL PRICE:	\$1,631.22	\$ 1,700.40	\$ 1,766.20

X9.4.4 Does the **BLADE – DOZER** you are providing meet or exceed specifications?
 YES NO

Manufacturer: Paladin

	MODEL: 96" Dozer Blade
Blade – Dozer	\$3,778.19
TOTAL PRICE:	\$ 3,778.19

X9.4.5 Does the **BOOM – MATERIAL HANDLING** you are providing meet or exceed the specifications?
 YES NO

Manufacturer: Paladin

	MODEL: 66" Material Handler
Boom – Material Handling	\$557.83
TOTAL PRICE:	\$ 557.83

X9.4.6 Does the **BREAKER – HYDRAULIC** you are providing meet or exceed the specifications? YES NO

Manufacturer: I-R Tramac

	MODEL: SC28
Breaker – Hydraulic	\$8,173.07

TOTAL PRICE: \$8,173.07

X9.4.7 Does the **BROOM – ANGLE – POLY/WIRE BRISTLES – WATER KIT WITH 25 GALLON TANK** you are providing meet or exceed the specifications? YES NO

Manufacturer: Sweepster

	MODEL: QC Angle Broom
Broom – Angle – Poly/Wire Bristles – Std. Manual Angle	\$3,927.76
Optional Water Kit with 25 Gallon Tank	\$848.00
Optional Hydraulic Angle	\$779.00

TOTAL PRICE: \$ 5,554.76

X9.4.8 Does the **BROOM – GENERAL PURPOSE PICK-UP** you are providing meet or exceed the specifications? YES NO

Manufacturer: Sweepster

	MODEL: SB Hopper Broom
Broom – General Purpose Pick-Up	\$3,432.47

TOTAL PRICE: \$ 3,432.47

**Specs call for optional Gutter Broom – Included in Price
No line to put as option.**

X9.4.9 Does the **BRUSH CUTTER** you are providing meet or exceed the specifications?
 YES NO

Manufacturer: Bradco

	MODEL: 104419
Brush Cutter	\$3,869.41

TOTAL PRICE: \$ 3,869.41

X9.4.10 Does the **BUCKET – BRUSH GRAPPLE** you are providing meet or exceed specifications?
 YES NO

Manufacturer: Paladin

Manufacturer: _____

	MODEL: 11384
Bucket – Brush Grapple	\$3,033.05

TOTAL PRICE: \$ 3,033.05

X9.4.11 Does the **BUCKET – FORKED SCRAP GRAPPLE** you are providing meet or exceed specifications?
 YES NO

Manufacturer: Paladin

	MODEL: FSG63	MODEL: FSG72
Bucket-Forked Scrap Grapple	\$3,234.51	\$3,347.14

TOTAL PRICE: \$ 3,234.51 \$3,347.14

X9.4.12 Does the **BUCKET – GENERAL PURPOSE** you are providing meet or exceed the specifications? YES NO

Manufacturer: Woods

	MODEL: 101444066	MODEL: 101444073	MODEL: 101491566	MODEL: 101491573
Bucket – General Purpose	\$757.08	\$779.14	\$792.01	\$823.18
Optional Teeth	\$217.00	\$217.00	\$217.00	\$217.00
Optional Bolt on Cutting Edge	\$128.00	\$128.00	\$128.00	\$128.00
Optional Bolt on Toothbar Inside Bucket Width	\$309.00	\$324.00	\$309.00	\$324.00

(NOTE: ADD ALL LINES FOR EVALUATION PURPOSES)

TOTAL PRICE \$ 1,411.08 _____ \$ 1,448.14 _____ \$ 1,446.01 _____ \$ 1,492.18 _____

X9.4.13 Do the **BUCKETS – GENERAL PURPOSE UTILITY & LIGHT MATERIAL** meet or exceed the specifications? YES NO

Manufacturer: Woods

	MODEL (GPU): 101734673	MODEL (LM): 101734773	MODEL (LM): 101734778	MODEL (LM): 101743784
Bucket (GPU)	\$984.51			
Bucket (LM)		\$1,146.24	\$1,221.96	\$1,304.75
Optional Bolt on Cutting Edge	\$128.00	\$128.00	\$128.00	\$128.00
Optional Bolt on Toothbar Inside Bucket Width	\$324.00	\$324.00	\$339.00	\$339.00

(NOTE: ADD ALL LINES FOR EVALUATION PURPOSES)

TOTAL PRICE \$1,436.51 _____ \$1,598.24 _____ \$ 1,688.96 _____ \$1,771.75 _____

X9.4.14 Does the **BUCKET – HEAVY DUTY SCRAP GRAPPLE** you are providing meet or exceed the specifications? YES NO

Manufacturer: Paladin

	MODEL: 11872	MODEL: 11876
Bucket – Heavy Duty Scrap Grapple	\$2,539.72	\$2,877.39
Optional Bolt on Cutting Edge	\$256.65	\$277.35

(NOTE: ADD ALL LINES FOR EVALUATION PURPOSES)

TOTAL PRICE: \$ 2,796.37 _____ \$ 3,154.74 _____

X9.4.15 Does the **BUCKET – MULTI PURPOSE** you are providing meet or exceed the specifications? YES NO

Manufacturer: Paladin

	MODEL 103565	MODEL: 103573
Bucket-Multi Purpose	\$2,310.12	\$3,962.24
Optional Bolt on Reversible Cutting Edge	\$325.00	\$350.00
Optional Bolt on Toothbar Inside Bucket Width	\$360.65	\$400.25

(NOTE: ADD ALL LINES FOR EVALUATION PURPOSES)

TOTAL PRICE: \$ 2,995.77 _____ \$ 4,712.49 _____

X9.4.16 Does the **BUCKET – ROCK** you are providing meet or exceed the specifications? YES NO

Manufacturer: FFC

	MODEL: 89646
Bucket – Rock	\$1,215.05

TOTAL PRICE: \$ 1,215.05 _____

X9.4.17 Does the **COLD PLANER** you are providing meet or exceed the specifications?
____X____ YES ____ NO

Manufacturer: Woods

	MODEL: CP12	MODEL: CP16	MODEL: CP18	MODEL: CP24	MODEL: CP30
Cold Planer	\$6,257.12	\$9,173.37	\$9,440.35	\$10,241.31	\$12,024.39

TOTAL PRICE: \$6,257.12 ____ \$9,173.37 ____ \$9,440.35 ____ \$10,241.31 ____ \$12,024.39 ____

X9.4.18 Does the **CONCRETE CLAW** you are providing meet or exceed the specifications?
____X____ YES ____ NO

Manufacturer: Paladin

	MODEL: 10024
Concrete Claw	\$1,375.81

TOTAL PRICE: \$ 1,375.81 ____

X9.4.19 Do the **FORKS – PALLET** you are providing meet or exceed the specifications?
____X____ YES ____ NO

Manufacturer: Paladin

	MODEL: 16870/57604
Forks – Pallet	\$774.30

TOTAL PRICE: \$ 774.30 ____

X9.4.20 Does the **GRAPPLE – LOG FORK** you are providing meet or exceed the specifications? YES NO

Manufacturer: Paladin

	MODEL: LAF1142
Grapple-Log Fork	\$2,815.56

TOTAL PRICE: \$ 2,815.56

X9.4.21 Does the **HITCH – THREE POINT** you are providing meet or exceed the specifications? YES NO

Manufacturer: Paladin

	MODEL: 88020
Hitch-Three Point	\$467.04

TOTAL PRICE: \$ 467.04

X9.4.22 Does the **POWER RAKE** you are providing meet or exceed the specifications? YES NO

Manufacturer: Paladin

	MODEL:
Power Rake	\$
Manual Angling Model #LAF5690	\$5,784.96
Hydraulic Angling Model LAF5690H	\$6,418.48

TOTAL MANUAL ANGLING PRICE: \$5,784.96

TOTAL HYDRAULIC ANGLING PRICE: \$6,418.48

X9.4.23 Does the **PREPARATOR** you are providing meet or exceed the specifications?
 YES NO

Manufacturer: Paladin

	MODEL: LAF3576
Preparator	\$6,089.95

TOTAL PRICE: \$ 6,089.95

X9.4.24 Does the **ROCK WHEEL WITH 50 GALLON WATER KIT** you are providing meet or exceed the specifications?
 YES NO

Manufacturer: Woods

	MODEL: RW12	MODEL: RW18	MODEL: RW24
Rock Wheel with 50 Gallon Water Kit	\$9,257.71	\$9,974.33	\$10,568.69

TOTAL PRICE: \$ 9,257.71 \$ 9,974.33 \$ 10,568.69

X9.4.25 Does the **ROLLER – VIBRATORY** you are providing meet or exceed the specifications?
 YES NO

Manufacturer: Paladin

	MODEL: 105066	MODEL: 105067
Roller – Vibratory	\$	\$
Smooth Drum	\$6,086.85	\$6,356.32
Padded Drum	\$6,186.85	\$6,456.32

TOTAL SMOOTH DRUM: \$ 6,086.85 \$ 6,186.85

TOTAL PADDED DRUM: \$ 6,356.32 \$ 6,456.32

X9.4.26 Does the **SCARIFIER** you are providing meet or exceed the specifications?
 YES NO

Manufacturer: Paladin

	MODEL: LAF2201
Scarifier	\$817.51

TOTAL PRICE: \$ 817.51

X9.4.27 Does the **SNOW BLADE** you are providing meet or exceed the specifications?
 YES NO

Manufacturer: Paladin

	MODEL: LAF1496
Snow Blade	\$1,992.58

TOTAL PRICE: \$ 1,992.58

X9.4.28 Does the **SNOW BLOWER** you are providing meet or exceed the specifications?
 YES NO

Manufacturer: Paladin

	MODEL: 11007D	MODEL: 6786H
Snow Blower	\$3,919.73	\$6,948.83

TOTAL PRICE: \$ 3,919.73 \$ 6,948.83

X9.4.29 Does the **STUMP GRINDER** you are providing meet or exceed the specifications?
 YES NO

Manufacturer: Woods

	MODEL: SG20	MODEL: SG40	MODEL: SG60
Stump Grinder	\$4,764.16	\$4,532.10	\$5,611.88

TOTAL PRICE: \$ 4,764.16 _____ \$ 4,532.10 _____ \$ 5,611.88 _____

X9.4.30 Does the **TILLER** you are providing meet or exceed the specifications?
 YES NO

Manufacturer: Woods

	MODEL: TL73	MODEL: TL84
Tiller	\$3,866.39	\$4,642.30

TOTAL PRICE: \$ 3,866.39 _____ \$ 4,642.30 _____

X9.4.31 Does the **TREE SPADE** you are providing meet or exceed the specifications?
 YES NO

Manufacturer: Paladin

	MODEL: TS36	MODEL: TS40	MODEL: TS42	MODEL: TS44	MODEL: TS48
Tree Spade	\$929.39	\$984.84	\$1,020.57	\$1,046.96	\$1,101.75

TOTAL PRICE: \$929.39 _____ \$ 984.84 _____ \$ 1,020.57 _____ \$ 1,046.96 _____ \$1,101.75 _____

X9.4.32 Does the **TRENCHER** you are providing meet or exceed the specifications? YES NO

Manufacturer: Lowe

	MODEL: XR14	MODEL: XR25	MODEL: XR35
Trencher	\$3,513.08	\$3,982.59	\$5,402.28
TOTAL PRICE:	\$ 3,513.08	\$3,982.59	\$ 5,402.28

GRAND TOTAL FOR ALL ATTACHMENTS: **\$ 286,301.98**



State of West Virginia
 Department of Administration
 Purchasing Division
 2019 Washington Street East
 Post Office Box 50130
 Charleston, WV 25305-0130

Request for Quotation

RFQ NUMBER:
 707EC020

PAGE:
 1

ADDRESS CORRESPONDENCE TO ATTENTION OF:
 JOHN JOHNSTON
 304-558-2402

RFQ COPY

TYPE NAME/ADDRESS HERE

V
E
N
D
O
R

Anderson Equipment Company
 P. O. Box 3109
 Charleston, WV 25331

S
H
I
P
T
O

DIVISION OF HIGHWAYS
 EQUIPMENT DIVISION
 ROUTE 33
 BRUSHY FORK ROAD
 BUCKHANNON, WV
 26201 304-472-1750

DATE PRINTED	TERMS OF SALE	SHIP VIA	F.O.B	FREIGHT TERMS
05/02/2007				

BID OPENING DATE: 05/09/2007 BID OPENING TIME 01:30PM

LINE	QUANTITY	UQP	CAT NO	ITEM NUMBER	UNIT PRICE	AMOUNT
				ADDENDUM NO. 3		
				CHANGES TO THE SPECIFICATIONS.		
				IF AN ATTACHMENT DOES NOT HAVE HYDRAULIC QUICK DISCONNECTS OR WIRING INSTALLED, INCLUDE THE HYDRAULIC DISCONNECTS AND WIRING HARNESS WITH THE ATTACHMENTS, HIGHWAYS WILL INSTALL. DO NOT INCLUDE LABOR IN YOUR PRICING FOR SUBJECT ATTACHMENTS.		
				BID OPENING DATE AND TIME REMAINS THE SAME.		
				NO OTHER CHANGES.		
0001	1	EA.		760-51		
				SKID STEER LOADER WITH ATTACHMENTS		
***** THIS IS THE END OF RFQ 707EC020 ***** TOTAL:						

SEE REVERSE SIDE FOR TERMS AND CONDITIONS

SIGNATURE	TELEPHONE	DATE
TITLE	FEIN	ADDRESS CHANGES TO BE NOTED ABOVE

WHEN RESPONDING TO RFQ, INSERT NAME AND ADDRESS IN SPACE ABOVE LABELED 'VENDOR'

**GENERAL TERMS & CONDITIONS
REQUEST FOR QUOTATION (RFQ) AND REQUEST FOR PROPOSAL (RFP)**

1. Awards will be made in the best interest of the State of West Virginia.
2. The State may accept or reject in part, or in whole, any bid.
3. All quotations are governed by the *West Virginia Code* and the *Legislative Rules* of the Purchasing Division.
4. Prior to any award, the apparent successful vendor must be properly registered with the Purchasing Division and have paid the required \$125.00 registration fee.
5. All services performed or goods delivered under State Purchase Orders/Contracts are to be continued for the term of the Purchase Order/Contract, contingent upon funds being appropriated by the Legislature or otherwise being made available. In the event funds are not appropriated or otherwise available for these services or goods, this Purchase Order/Contract becomes void and of no effect after June 30.
6. Payment may only be made after the delivery and acceptance of goods or services.
7. Interest may be paid for late payment in accordance with the *West Virginia Code*.
8. Vendor preference will be granted upon written request in accordance with the *West Virginia Code*.
9. The State of West Virginia is exempt from federal and state taxes and will not pay or reimburse such taxes.
10. The Director of Purchasing may cancel any Purchase Order/Contract upon 30 days written notice to the seller.
11. The laws of the State of West Virginia and the *Legislative Rules* of the Purchasing Division shall govern all rights and duties under the Contract, including without limitation the validity of this Purchase Order/Contract.
12. Any reference to automatic renewal is hereby deleted. The Contract may be renewed only upon mutual written agreement of the parties.
13. **BANKRUPTCY:** In the event the vendor/contractor files for bankruptcy protection, this contract is automatically null and void, and is terminated without further order.
14. **HIPAA Business Associate Addendum** - The West Virginia State Government HIPAA Business Associate Addendum (BAA), approved by the Attorney General, and available online at the Purchasing Division's web site (<http://www.state.wv.us/admin/purchase/vrc/hipaa.htm>) is hereby made part of the agreement. Provided that, the Agency meets the definition of a Covered Entity (45 CFR §160.103) and will be disclosing Protected Health Information (45 CFR §160.103) to the vendor.

INSTRUCTIONS TO BIDDERS

1. Use the quotation forms provided by the Purchasing Division.
2. **SPECIFICATIONS:** Items offered must be in compliance with the specifications. Any deviation from the specifications must be clearly indicated by the bidder. Alternates offered by the bidder as **EQUAL** to the specifications must be clearly defined. A bidder offering an alternate should attach complete specifications and literature to the bid. The Purchasing Division may waive minor deviations to specifications.
3. Complete all sections of the quotation form.
4. Unit prices shall prevail in cases of discrepancy.
5. All quotations are considered F.O.B. destination unless alternate shipping terms are clearly identified in the quotation.
6. **BID SUBMISSION:** All quotations must be delivered by the bidder to the office listed below prior to the date and time of the bid opening. Failure of the bidder to deliver the quotations on time will result in bid disqualifications.

SIGNED BID TO:

Department of Administration
Purchasing Division
2019 Washington Street East
Post Office Box 50130
Charleston, WV 25305-0130



State of West Virginia
 Department of Administration
 Purchasing Division
 2019 Washington Street East
 Post Office Box 50130
 Charleston, WV 25305-0130

Request for Quotation

RFQ NUMBER
707EC020

PAGE
1

ADDRESS CORRESPONDENCE TO ATTENTION OF
JOHN JOHNSTON 304-558-2402

RFQ COPY
 TYPE NAME/ADDRESS HERE
 Anderson Equipment Company
 P. O. Box 3109
 Charleston, WV 25331

DIVISION OF HIGHWAYS
 EQUIPMENT DIVISION
 ROUTE 33
 BRUSHY FORK ROAD
 BUCKHANNON, WV
 26201 304-472-1750

DATE PRINTED 05/04/2007	TERMS OF SALE	SHIP VIA	F.O.B.	FREIGHT TERMS
----------------------------	---------------	----------	--------	---------------

BID OPENING DATE: 05/09/2007 BID OPENING TIME 01:30PM

LINE	QUANTITY	UOF	CAT NO	ITEM NUMBER	UNIT PRICE	AMOUNT
ADDENDUM NO. 4						
CHANGES TO THE SPECIFICATIONS PER THE ATTACHED.						
BID OPENING DATE AND TIME REMAINS THE SAME.						
NO OTHER CHANGES.						
0001	1	EA		760-51		
SKID STEER LOADER WITH ATTACHMENTS						
***** THIS IS THE END OF RFQ 707EC020 ***** TOTAL:						

SEE REVERSE SIDE FOR TERMS AND CONDITIONS

SIGNATURE	TELEPHONE	DATE
TITLE	FEIN	ADDRESS CHANGES TO BE NOTED ABOVE

WHEN RESPONDING TO RFQ, INSERT NAME AND ADDRESS IN SPACE ABOVE LABELED 'VENDOR'

ADDENDUM NO. 4

Changes to the specifications on Addendum No. 2

Page 14

ROCK WHEEL
WITH 50 GALLON
WATER KIT

RW 12

RW 18

RW 24

READS:

Width of Cut

2.5/4.5 in

2.5/4.5 in

2.5/4.5 in

TO READ:

2.5

2.5

2.5

Page 24

Bottom of Page

READS:

MODEL:

TO READ:

MODEL: FSG63MODEL: FSG72

Page 25

Top of Page

READS:

TOTAL PRICE:

TO READ:

TOTAL PRICE \$ 3,234.51TOTAL PRICE \$ 3,347.14

Page 29

X9.4.24

NO CHANGES

**GENERAL TERMS & CONDITIONS
REQUEST FOR QUOTATION (RFQ) AND REQUEST FOR PROPOSAL (RFP)**

1. Awards will be made in the best interest of the State of West Virginia.
2. The State may accept or reject in part, or in whole, any bid.
3. All quotations are governed by the *West Virginia Code* and the *Legislative Rules* of the Purchasing Division.
4. Prior to any award, the apparent successful vendor must be properly registered with the Purchasing Division and have paid the required \$125.00 registration fee.
5. All services performed or goods delivered under State Purchase Orders/Contracts are to be continued for the term of the Purchase Order/Contract, contingent upon funds being appropriated by the Legislature or otherwise being made available. In the event funds are not appropriated or otherwise available for these services or goods, this Purchase Order/Contract becomes void and of no effect after June 30.
6. Payment may only be made after the delivery and acceptance of goods or services.
7. Interest may be paid for late payment in accordance with the *West Virginia Code*.
8. Vendor preference will be granted upon written request in accordance with the *West Virginia Code*.
9. The State of West Virginia is exempt from federal and state taxes and will not pay or reimburse such taxes.
10. The Director of Purchasing may cancel any Purchase Order/Contract upon 30 days written notice to the seller.
11. The laws of the State of West Virginia and the *Legislative Rules* of the Purchasing Division shall govern all rights and duties under the Contract, including without limitation the validity of this Purchase Order/Contract.
12. Any reference to automatic renewal is hereby deleted. The Contract may be renewed only upon mutual written agreement of the parties.
13. **BANKRUPTCY:** In the event the vendor/contractor files for bankruptcy protection, this contract is automatically null and void, and is terminated without further order.
14. **HIPAA Business Associate Addendum -** The West Virginia State Government HIPAA Business Associate Addendum (BAA), approved by the Attorney General, and available online at the Purchasing Division's web site (<http://www.state.wv.us/admin/purchase/vrc/hipaa.htm>) is hereby made part of the agreement. Provided that, the Agency meets the definition of a Covered Entity (45 CFR §160.103) and will be disclosing Protected Health Information (45 CFR §160.103) to the vendor.

INSTRUCTIONS TO BIDDERS

1. Use the quotation forms provided by the Purchasing Division.
2. **SPECIFICATIONS:** Items offered must be in compliance with the specifications. Any deviation from the specifications must be clearly indicated by the bidder. Alternates offered by the bidder as **EQUAL** to the specifications must be clearly defined. A bidder offering an alternate should attach complete specifications and literature to the bid. The Purchasing Division may waive minor deviations to specifications.
3. Complete all sections of the quotation form.
4. Unit prices shall prevail in cases of discrepancy.
5. All quotations are considered F.O.B. destination unless alternate shipping terms are clearly identified in the quotation.
6. **BID SUBMISSION:** All quotations must be delivered by the bidder to the office listed below prior to the date and time of the bid opening. Failure of the bidder to deliver the quotations on time will result in bid disqualifications.

SIGNED BID TO:

Department of Administration
Purchasing Division
2019 Washington Street East
Post Office Box 50130
Charleston, WV 25305-0130

PURCHASING CONTINUATION SHEET

Buyer: JJ-33	Page 33	Req. or P.O. No.: 707EC020
Spending Unit:		

Vendor:

Requisition No.: 707EC020

ADDENDUM ACKNOWLEDGEMENT

I hereby acknowledge receipt of the following checked addendum(s) and have made the necessary revisions to my proposal, plans and/or specifications, etc.

Addendum No.'s:

No. 1 X
 No. 2 X
 No. 3 X
 No. 4 X
 No. 5

I understand that failure to confirm the receipt of the addendum(s) may be cause for rejection of bids.

Michael K. Burke / t/s
 Signature

Anderson Equipment Company
 Company

May 8, 2007

Date

EXHIBIT 10

GEHL

SKID LOADER AND TRACK LOADER WARRANTY

GEHL COMPANY, hereinafter referred to as Gehl, warrants new Gehl Skid and Track Loaders to the Original Retail Purchaser to be free from defects in material and workmanship for a period of twelve (12) months from the Warranty Start Date.

GEHL WARRANTY SERVICE INCLUDES:

Genuine Gehl parts and labor costs required to repair or replace equipment at the selling dealer's business location.

GEHL MAKES NO REPRESENTATIONS OR WARRANTIES OF ANY KIND, EXPRESS OR IMPLIED (INCLUDING THE IMPLIED WARRANTIES OF MERCHANTABILITY AND FITNESS FOR PARTICULAR PURPOSE), EXCEPT AS EXPRESSLY STATED IN THE WARRANTY STATEMENT.

GEHL WARRANTY SERVICE DOES NOT INCLUDE:

1. Transportation to selling dealer's business location or, at the option of the Original Retail Purchaser, the cost of a service call.
2. Used equipment.
3. Components covered by their own non-Gehl warranties, such as tires, trade accessories, and engines.
4. Normal maintenance service and expendable, high-wear items.
5. Repairs or adjustments caused by: improper use, failure to follow recommended maintenance procedures, use of unauthorized attachments, accident or other casualty.
6. Liability for incidental or consequential damages of any type, including but not limited to lost profits or expenses of acquiring replacement equipment.

No agent, employee, or representative of Gehl has any authority to bind Gehl to any warranty except as specifically set forth herein. Any of these limitations excluded by local law shall be deemed deleted from this warranty; all other terms will continue to apply.



State of West Virginia

May 4th, 2007

Subject: Warranty Bradco, McMillan, Sweepster, FFC

All the products purchased by the State of West Virginia from the bid opening May 9th, 2007 will have two year warranty coverage. All terms, conditions and other provisions of the standard Paladin Light Construction warranty remain in effect.

Jerry Jelen
Vice President - Dealer Sales
Paladin Light Construction
612-616-5981
jjelen@paladinbrands.com

CC *Jeremy Turncamp*
Randy Thorson
Dave Aldrich
Kathy Grau
Wendell Moss

WARRANTY

Ingersoll Rand Attachments

Ingersoll Rand Company warrants to its authorized dealers and authorized dealers of Ingersoll Rand Equipment Ltd., who in turn warrant to the original owner, that each new Ingersoll Rand attachment will be free from proven defects in material and workmanship for twelve (12) months after delivery by the authorized Ingersoll Rand dealer to the original buyer.

During the warranty period, the authorized Ingersoll Rand dealer shall repair or replace, at Ingersoll Rand Company's option, without charge for parts and labor, any part of the Ingersoll Rand product which fails because of defects in material or workmanship. The owner shall provide the authorized Ingersoll Rand dealer with prompt written notice of the defect and allow reasonable time for replacement or repair. Ingersoll Rand Company may, at its option, require failed parts to be returned to the factory. Travel time of mechanics and transportation of the Ingersoll Rand product to the authorized Ingersoll Rand dealer for warranty work are the responsibility of the owner. The remedies provided in this warranty are exclusive.

This warranty does not cover replacement of scheduled service items and high wear items. The owner shall rely solely on the warranty, if any, of the respective manufacturers thereof. This warranty does not cover damages resulting from abuse, accidents, alterations, use of the Ingersoll Rand product as an attachment on any equipment not approved by Ingersoll Rand Company, air flow obstructions, or failure to maintain or use the Ingersoll Rand product according to the instructions applicable to it.

THIS WARRANTY IS EXCLUSIVE AND IN LIEU OF ALL OTHER WARRANTIES AND CONDITIONS, EXCEPT THE WARRANTY OF TITLE. INGERSOLL RAND COMPANY DISCLAIMS ALL OTHER WARRANTIES AND CONDITIONS, EXPRESS OR IMPLIED, INCLUDING ANY IMPLIED WARRANTIES OR CONDITIONS OF MERCHANTABILITY OR FITNESS FOR A PARTICULAR PURPOSE. IN NO EVENT SHALL INGERSOLL RAND COMPANY OR THE AUTHORIZED INGERSOLL RAND DEALER BE LIABLE FOR ANY SPECIAL, INCIDENTAL, INDIRECT OR CONSEQUENTIAL DAMAGES, WHATSOEVER, INCLUDING, BUT NOT LIMITED TO, LOSS OF INTERRUPTION OF BUSINESS, LOST PROFITS, OR LOSS OF MACHINE USE, WHETHER BASED ON CONTRACT, WARRANTY, TORT, NEGLIGENCE, STRICT LIABILITY, STATUTE OR OTHERWISE, EVEN IF INGERSOLL RAND COMPANY OR THE AUTHORIZED INGERSOLL RAND DEALER HAS BEEN ADVISED OF THE POSSIBILITY OF SUCH DAMAGES. THE TOTAL LIABILITY OF INGERSOLL RAND COMPANY AND THE AUTHORIZED INGERSOLL RAND DEALERS WITH RESPECT TO THE PRODUCT AND SERVICES FURNISHED HEREUNDER SHALL NOT EXCEED THE PURCHASE PRICE OF THE PRODUCT UPON WHICH SUCH LIABILITY IS BASED.



Toll Free: 1-800-356-9180
PHONE: 608-538-4000
FAX: 608-538-3995
E-mail: Lowe@Loweman.com
www.loweman.com



Manufacturing Co., Inc.

(Ship-to)
18903 High Point Road
Viola, WI 54664

(Mail-to)
Post Office Box 275
Readstown, WI 54652

LOWE Warranty Policy per Operator's Manual

Lowe Manufacturing Company, Incorporated, (LOWE) is proud of its reputation for producing products with high standards of quality and workmanship. When LOWE products are used and maintained in the prescribed manner, you can be assured they will provide reliable service.

Period of Warranty: Any new LOWE product purchased and registered with LOWE will be warranted against defects in materials and workmanship for a period of two years from the date of purchase, subject to the exclusions noted herein. Replacement parts used in warranty repairs will be warranted for the balance of the applicable warranty period.

Warranty Registration: To be eligible for warranty coverage, LOWE product(s) must first be registered with LOWE. A warranty registration form is provided in the Operator's Manual. This form must be completed, signed, and mailed to LOWE by either the authorized selling dealer or the purchaser.

Customer's Responsibility: Under the terms of this warranty, the customer will be responsible for ensuring the product is properly operated and maintained as specified in the Operator's Manual. The owner of the product shall give notice to an authorized dealer of any and all apparent defects within ten (10) days of discovery and make the product available for inspection and repairs at the dealer's place of business. Dealers must contact Lowe for authorization of any warranty work.

The customer's responsibilities include all costs of normal maintenance, replacement wear parts, non-warranty repairs, accidents, collision damage, and other repairs resulting from abnormal strain, neglect, or abuse. Specific examples include, but are not limited to, bending or prying with the product, failure to monitor wear, use of contaminated hydraulic fluid, excessive oil flow or pressure, and operation with a broken or damaged part which causes another part to fail. The customer is also responsible for incidental costs such as transportation due to failure. If you have any specific questions on operation or maintenance, please contact your dealer for advice.

General Exclusions From Warranty: This warranty is not transferable and applies only to the original owner of the equipment. It does not apply to products sold or used previously, products subject to misuse, service other than normal, damage in transit or handling, normal wear, or products in the opinion of Lowe have had unauthorized alterations or repair.

LOWE will replace any warrantable parts with original LOWE parts. LOWE will not pay for unauthorized parts, nor will it pay for freight, labor, travel time, or mileage connected with the replacement of warranty parts. LOWE will also not pay third party repair or replacement charges.

All defective parts against which warranty claims are made must be returned to LOWE, freight prepaid, in accordance with the LOWE Official Return Policy current at the time of the warranty claim. The hydraulic motor(s) used in LOWE products are warranted by the motor manufacturer and, in case of possible warranty failure, must be returned to LOWE or the nearest authorized hydraulic motor distributor for service. Any attempt by you, your dealer, or another company to repair the motor will result in denial of warranty credit.

This warranty is in lieu of all other warranties, expressed or implied. Any claims for incidental or consequential damages are hereby disclaimed by LOWE and excluded from this warranty. LOWE neither assumes nor authorizes any person or company to assume for it any other obligations or liabilities in connection with its products.

This warranty gives you specific legal rights, and you may also have other rights which vary from state to state.

Model Number _____ Serial Number _____ Date Purchased _____
Owner's Name & Address _____
Dealer's Name _____
Dealer's Address _____
City _____ State _____ - _____ Zip _____
Dealer's Phone Number _____

WARRANTY
Construction Equipment

Please Enter Information Below and Save for Future Reference.

Date of Purchase: _____ From (Dealer): _____

Model Number: _____ Serial Number: _____

Woods Equipment Company ("WOODS") warrants this product to be free from defects in material and workmanship. Except as otherwise set forth below, the duration of this Warranty shall be twelve (12) months commencing on the in-service date of the product or fifteen months after shipment from the factory or 1,500 hours of service, whichever occurs first. Proof of the in-service date must be provided for claims involving product that originally shipped more than twelve (12) months prior to the date of the claim.

Under no circumstances will this Warranty apply in the event that the product, in the good faith opinion of WOODS, has been subjected to improper operation, improper maintenance, misuse, inappropriate application or an accident. This Warranty does not apply in the event that the product has been materially modified or repaired by someone other than WOODS, a WOODS authorized dealer or distributor, and/or a WOODS authorized service center. This Warranty does not cover normal wear and tear, or normal maintenance items, as more specifically described below. This Warranty also does not cover repairs made with parts other than those obtainable through WOODS.

This Warranty is extended solely to the original purchaser of new and unused product, including, but not limited to, purchases made from authorized Woods dealers. Should such original purchaser sell or otherwise transfer this product to a third party, this Warranty does not transfer to the third party purchaser in any way. There are no third party beneficiaries of this Warranty.

WOODS' obligation under this Warranty is limited to, at WOODS' option, the repair or replacement, free of charge, of the product if WOODS, in its sole discretion, deems it to be defective or in noncompliance with this Warranty. **The product must be returned to WOODS with proof of purchase within thirty (30) days after such defect or noncompliance is discovered or should have been discovered, routed through the dealer and distributor from whom the purchase was made, transportation charges prepaid.** WOODS shall complete such repair or replacement within a reasonable time after WOODS receives the product. **THERE ARE NO OTHER REMEDIES UNDER THIS WARRANTY. THE REMEDY OF REPAIR OR REPLACEMENT IS THE SOLE AND EXCLUSIVE REMEDY UNDER THIS WARRANTY.** THERE ARE NO WARRANTIES, WHICH EXTEND BEYOND THE DESCRIPTION ON THE FACE OF THIS WARRANTY. WOODS MAKES NO OTHER WARRANTY, EXPRESS OR IMPLIED, AND WOODS SPECIFICALLY DISCLAIMS ANY IMPLIED WARRANTY OF MERCHANTABILITY AND/OR ANY IMPLIED WARRANTY OF FITNESS FOR A PARTICULAR PURPOSE.

WOODS shall not be liable for any incidental or consequential losses, damages or expenses, arising directly or indirectly from the product, whether such claim is based upon breach of contract, breach of warranty, negligence, strict liability in tort or any other legal theory. Without limiting the generality of the foregoing, WOODS specifically disclaims any damages relating to (i) lost profits, business, revenue or goodwill; (ii) any expense or loss incurred for labor, supplies, substitute machinery or rental; or (iii) any other type of damage to property or economic loss.

This Warranty is subject to any existing conditions of supply, which may directly affect WOODS' ability to obtain materials or manufacturer replacement parts.

No agent, representative, dealer, distributor, serviceperson, or employee of any company, including without limitation, WOODS, its authorized dealers, distributors, and service centers, is authorized to alter, modify or enlarge this Warranty.

Contact an authorized WOODS dealer or service center for warranty service. Common issues that would NOT be covered by this Warranty Policy include, but are not limited to, the examples listed below this Policy.

**Woods Equipment
Company**

2606 South Illinois Route 2
Post Office Box 1000
Oregon, Illinois 61061

800-848-3447 CE tel
815-732-2141 tel
815-732-7580 fax

www.WoodsEquipment.com



**ALITEC™
BMP®**

CENTRAL FABRICATORS®

GANNON®

GILL®

WAIN-ROY®

WOODS®

Examples of Common, Non-Covered Claims

1. The owner and operator are responsible for maintaining weld integrity on attachments subject to weld erosion from ongoing contact with soils, rocks, and other materials. Different materials have differing abrasive characteristics that will erode the structural welds of ground-engaging attachments at differing rates. Structural failures may occur as a result of excessive weld erosion. The owner and operator are responsible for maintaining necessary weld sizes and re-welding eroded welds with industry-approved procedures. Woods will not accept warranty claims for weld erosion or structural failures of the attachment as a result of weld erosion.
2. Attachments are used extensively in ground-engaging operations and, as a result, the teeth, tooth holders, cutting edges, bucket edges, ripper shanks, and other portions of the attachment are subject to abrasion and resulting wear. Woods will not accept warranty claims for wear of components or wear of areas of the attachment subject to ground-engaging wear.
3. The owner and operator are responsible for examining the attachment for any weld or structural cracking. Any such cracking caused by a defect in materials or workmanship by Woods will be covered under the Woods Warranty Policy. If the owner or operator continues to operate the attachment after weld cracking or structural cracking is visible or should have reasonably been visible, and as a result of continued operation, additional damage to the attachment results, Woods will not accept responsibility for the additional damage caused to other welds or to the attachment structure.
4. Materially modifying Woods attachments may result in premature failures of the attachment. Woods will not accept warranty claims on attachments that have been materially modified.
5. Misapplications of attachments may result in premature wear, breakage, or structural failures of the attachment. Woods will not accept warranty claims on attachments that have been misapplied. For instance, using a general purpose excavator bucket in an application requiring a heavy or severe duty bucket or using the excavator bucket as a "jack hammer" to break concrete are considered misapplications.

 **BRADCO**

 **FFC**

 **HARLEY**

 **MAJOR**

 **MCMILLEN**

 **SWEEPSTER**

PALADIN LIGHT CONSTRUCTION

**Bradco, McMillen, The Major
Light Construction Headquarters**
P.O. Box 266
Delhi, IA 52223
United States of America

**PH 563-922-2981
FX 563-922-2700**

FFC
100 E. Lee Road
Lee, IL 60530
United States of America

**PH 800-747-2132
FX 815-824-2520**

Sweepster
2800 N. Zeeb Road
Dexter, MI 48130
United States of America

**PH 800-456-7100
FX 734-996-9014**

Harley
1805 2nd Ave. S.W.
P.O. Box 230
Jamestown, ND 58402
United States of America

**PH 800-437-9779
FX 701-252-1978**

410 Hwy 71E
P.O. Box 558
Clarissa, MN 56440

**PH 218-756-2378
FX 218-756-2492**

www.paladinbrands.com

SWEEPSTER Limited Warranty Two (2) Years Warranty

For a period of Two (2) years from the date of delivery of product to the original user, Sweepster Attachments LLC Of Dexter, Michigan warrants each product to be free from defects, subject to the limitations contained in this policy.

This warranty does not apply to defects caused, in whole or in part, by unreasonable use while in the possession of the user, including, but not limited to: failure to properly set up product; failure to provide reasonable and necessary maintenance; normal wear; routine tune ups or adjustments; improper handling or accidents; operation at speed or load conditions contrary to published specifications; improper or insufficient lubrication; improper storage. This warranty is also not a guarantee that the performance of each product will meet the expectations of the purchaser.

Sweepster Attachments LLC shall not be liable for consequential damages of any kind, including, but not limited to: consequential labor costs or transportation charges in connection with the replacement or repair of defective parts; lost time or expense which may have accrued because of said defects. In no event shall Sweepster Attachments LLC total liability hereunder exceed the product purchase price.

Sweepster Attachments LLC makes no warranty with respect to trade accessories or any component or accessory of the product, which was not manufactured by Sweepster Attachments LLC including any purchased components of any kind. These are subject to the warranties of their respective manufacturers. The warranty will be considered void if the product or any part of the product is modified or repaired in any way not expressly authorized by Sweepster Attachments LLC, or if closed components are disassembled prior to return. Closed components include, but are not limited to: gearboxes, hydraulic pumps, motors, cylinders, and actuators.

Our obligation under this warranty is expressly limited, at our option, to the replacement or repair at Sweepster Attachments LLC of Dexter, Michigan, or at a service facility designated by us, or such part or parts as inspection shall disclosed to have been defective. We are not responsible for unauthorized repairs or replacements. **ANY IMPLIED OR STATUARY WARRANTIES, INCLUDING ANY WARRANTY OF MERCHANTABILITY OR FITNESS FOR A PARTICULAR PURPOSE, ARE EXPRESSLY LIMITED TO THE DURATION OF THIS WRITTEN WARRANTY. WE MAKE NO OTHER EXPRESS WARRANTY, NOR IS ANYONE AUTHORIZED TO MAKE ANY IN OUR BEHALF.** This warranty cannot be extended, broadened, or changed except in writing by an authorized officer of Sweepster Attachments LLC.



PALADIN LIGHT CONSTRUCTION

SWEEPSTER Limited Warranty Two (2) Years Warranty

For a period of Two (2) years from the date of delivery of product to the original user, Sweepster Attachments LLC Of Dexter, Michigan warrants each product to be free from defects, subject to the limitations contained in this policy.

This warranty does not apply to defects caused, in whole or in part, by unreasonable use while in the possession of the user, including, but not limited to: failure to properly set up product; failure to provide reasonable and necessary maintenance; normal wear; routine tune ups or adjustments; improper handling or accidents; operation at speed or load conditions contrary to published specifications; improper or insufficient lubrication; improper storage. This warranty is also not a guarantee that the performance of each product will meet the expectations of the purchaser.

Sweepster Attachments LLC shall not be liable for consequential damages of any kind, including, but not limited to: consequential labor costs or transportation charges in connection with the replacement or repair of defective parts; lost time or expense which may have accrued because of said defects. In no event shall Sweepster Attachments LLC total liability hereunder exceed the product purchase price.

Sweepster Attachments LLC makes no warranty with respect to trade accessories or any component or accessory of the product, which was not manufactured by Sweepster Attachments LLC including any purchased components of any kind. These are subject to the warranties of their respective manufacturers. The warranty will be considered void if the product or any part of the product is modified or repaired in any way not expressly authorized by Sweepster Attachments LLC, or if closed components are disassembled prior to return. Closed components include, but are not limited to: gearboxes, hydraulic pumps, motors, cylinders, and actuators.

Our obligation under this warranty is expressly limited, at our option, to the replacement or repair at Sweepster Attachments LLC of Dexter, Michigan, or at a service facility designated by us, or such part or parts as inspection shall disclosed to have been defective. We are not responsible for unauthorized repairs or replacements. **ANY IMPLIED OR STATUARY WARRANTIES, INCLUDING ANY WARRANTY OF MERCHANTABILITY OR FITNESS FOR A PARTICULAR PURPOSE, ARE EXPRESSLY LIMITED TO THE DURATION OF THIS WRITTEN WARRANTY. WE MAKE NO OTHER EXPRESS WARRANTY, NOR IS ANYONE AUTHORIZED TO MAKE ANY IN OUR BEHALF.** This warranty cannot be extended, broadened, or changed except in writing by an authorized officer of Sweepster Attachments LLC.

**Bradco, McMillen, The Major
Light Construction Headquarters**
P.O. Box 266
Delhi, IA 52223
United States of America

PH 563-922-2981
FX 563-922-2700

FFC
100 E. Lee Road
Lee, IL 60530
United States of America

PH 800-747-2132
FX 815-824-2620

Sweepster
2800 N. Zeeb Road
Dexter, MI 48130
United States of America

PH 800-456-7100
FX 734-996-9014

Harley
1805 2nd Ave. S.W.
P.O. Box 230
Jamestown, ND 58402
United States of America

PH 800-437-9779
FX 701-252-1978

410 Hwy 71E
P.O. Box 558
Clarissa, MN 56440

PH 218-756-2378
FX 218-756-2492

AGREEMENT ADDENDUM

WV-96
Rev. 5/94

In the event of conflict between this addendum and the agreement, this addendum shall control:

1. **ARBITRATION** - Any references to arbitration contained in the agreement are hereby deleted. Disputes arising out of the agreement shall be presented to the West Virginia Court of Claims.
2. **HOLD HARMLESS** - Any clause requiring the Agency to indemnify or hold harmless any party is hereby deleted in its entirety.
3. **GOVERNING LAW** - The agreement shall be governed by the laws of the State of West Virginia. This provision replaces any references to any other State's governing law.
4. **TAXES** - Provisions in the agreement requiring the Agency to pay taxes are deleted. As a State entity, the Agency is exempt from Federal, State, and local taxes and will not pay taxes for any Vendor including individuals, nor will the Agency file any tax returns or reports on behalf of Vendor or any other party.
5. **PAYMENT** - Any references to prepayment are deleted. Payment will be in arrears.
6. **INTEREST** - Should the agreement include a provision for interest on late payments, the Agency agrees to pay the maximum legal rate under West Virginia law. All other references to interest or late charges are deleted.
7. **RECOUPMENT** - Any language in the agreement waiving the Agency's right to set-off, counterclaim, recoupment, or other defense is hereby deleted.
8. **FISCAL YEAR FUNDING** - Service performed under the agreement may be continued in succeeding fiscal years for the term of the agreement, contingent upon funds being appropriated by the Legislature or otherwise being available for this service. In the event funds are not appropriated or otherwise available for this service, the agreement shall terminate without penalty on June 30. After that date, the agreement becomes of no effect and is null and void. However, the Agency agrees to use its best efforts to have the amounts contemplated under the agreement included in its budget. Non-appropriation or non-funding shall not be considered an event of default.
9. **STATUTE OF LIMITATION** - Any clauses limiting the time in which the Agency may bring suit against the Vendor, lessor, individual, or any other party are deleted.
10. **SIMILAR SERVICES** - Any provisions limiting the Agency's right to obtain similar services or equipment in the event of default or non-funding during the term of the agreement are hereby deleted.
11. **ATTORNEY FEES** - The Agency recognizes an obligation to pay attorney's fees or costs only when assessed by a court of competent jurisdiction. Any other provision is invalid and considered null and void.
12. **ASSIGNMENT** - Notwithstanding any clause to the contrary, the Agency reserves the right to assign the agreement to another State of West Virginia agency, board or commission upon thirty (30) days written notice to the Vendor and Vendor shall obtain the written consent of Agency prior to assigning the agreement.
13. **LIMITATION OF LIABILITY** - The Agency, as a State entity, cannot agree to assume the potential liability of a Vendor. Accordingly, any provision limiting the Vendor's liability for direct damages or limiting the Vendor's liability under a warranty to a certain dollar amount or to the amount of the agreement is hereby deleted. In addition, any limitation is null and void to the extent that it precludes any action for injury to persons or for damages to personal property.
14. **RIGHT TO TERMINATE** - Agency shall have the right to terminate the agreement upon thirty (30) days written notice to Vendor.
15. **TERMINATION CHARGES** - Any provision requiring the Agency to pay a fixed amount or liquidated damages upon termination of the agreement is hereby deleted. The Agency may only agree to reimburse a Vendor for actual costs incurred or losses sustained during the current fiscal year due to wrongful termination by the Agency prior to the end of any current agreement term.
16. **RENEWAL** - Any reference to automatic renewal is hereby deleted. The agreement may be renewed only upon mutual written agreement of the parties.
17. **INSURANCE** - Any provision requiring the Agency to insure equipment or property of any kind and name the Vendor as beneficiary or as an additional insured is hereby deleted.
18. **RIGHT TO NOTICE** - Any provision for repossession of equipment without notice is hereby deleted. However, the Agency does recognize a right of repossession with notice.
19. **ACCELERATION** - Any reference to acceleration of payments in the event of default or non-funding is hereby deleted.
20. **AMENDMENTS** - All amendments, modifications, alterations or changes to the agreement shall be in writing and signed by both parties. No amendment, modification, alteration or change may be made to this addendum without the express written approval of the Purchasing Division and the Attorney General.

ACCEPTED BY:
STATE OF WEST VIRGINIA

Spending Unit: _____

Signed: _____

Title: _____

Date: _____

VENDOR

Company Name: Anderson Equipment Company

Signed: Michael K. Burke Hls

Title: General Manager - WV

Date: May 8, 2007

AFFIDAVIT

West Virginia Code §5A-3-10a states:

No contract or renewal of any contract may be awarded by the state or any of its political subdivisions to any vendor or prospective vendor when the vendor or prospective vendor or a related party to the vendor or prospective vendor is a debtor and the debt owned is an amount greater than one thousand dollars in the aggregate

DEFINITIONS:

"Debt" means any assessment, premium, penalty, fine, tax or other amount of money owed to the state or any of its political subdivisions because of a judgment, fine, permit violation, license assessment, defaulted workers' compensation premium, penalty or other assessment presently delinquent or due and required to be paid to the state or any of its political subdivisions, including any interest or additional penalties accrued thereon.

"Debtor" means any individual, corporation, partnership, association, limited liability company or any other form or business association owing a debt to the state or any of its political subdivisions. "Political subdivision" means any county commission; municipality; county board of education; any instrumentality established by a county or municipality; any separate corporation or instrumentality established by one or more counties or municipalities, as permitted by law; or any public body charged by law with the performance of a government function or whose jurisdiction is coextensive with one or more counties or municipalities. "Related party" means a party, whether an individual, corporation, partnership, association, limited liability company or any other form or business association or other entity whatsoever, related to any vendor by blood, marriage, ownership or contract through which the party has a relationship of ownership or other interest with the vendor so that the party will actually or by effect receive or control a portion of the benefit, profit or other consideration from performance of a vendor contract with the party receiving an amount that meets or exceeds five percent of the total contract amount.

EXCEPTION:

The prohibition of this section does not apply where a vendor has contested any tax administered pursuant to chapter eleven of this code, workers' compensation premium, permit fee or environmental fee or assessment and the matter has not become final or where the vendor has entered into a payment plan or agreement and the vendor is not in default of any of the provisions of such plan or agreement.

LICENSING:

Vendors must be licensed and in good standing in accordance with any and all state and local laws and requirements by any state or local agency of West Virginia, including, but not limited to, the West Virginia Secretary of State's Office, the West Virginia Tax Department, West Virginia Insurance Commission, or any other state agencies or political subdivision. Furthermore, the vendor must provide all necessary releases to obtain information to enable the Director or spending unit to verify that the vendor is licensed and in good standing with the above entities.

CONFIDENTIALITY:

The vendor agrees that he or she will not disclose to anyone, directly or indirectly, any such personally identifiable information or other confidential information gained from the agency, unless the individual who is the subject of the information consents to the disclosure in writing or the disclosure is made pursuant to the agency's policies, procedures and rules. Vendors should visit www.state.wv.us/admin/purchase/privacy for the Notice of Agency Confidentiality Policies.

Under penalty of law for false swearing (West Virginia Code, §61-5-3), it is hereby certified that the vendor acknowledges the information in this said affidavit and are in compliance with the requirements as stated.

Vendor's Name: Anderson Equipment Company

Authorized Signature: Michael K. Burke / tlb Date: May 8, 2007

Michael K. Burke

GEHL

E - SERIES

Skid Loaders



GEHL



Boost Job Site Productivity

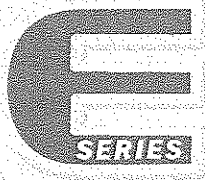

When it comes to different jobs in a variety of applications and conditions, there isn't much the E-Series can't handle. Power, speed reach, operator comfort and visibility.

It's everything you want in a rugged, simple, dependable machine.



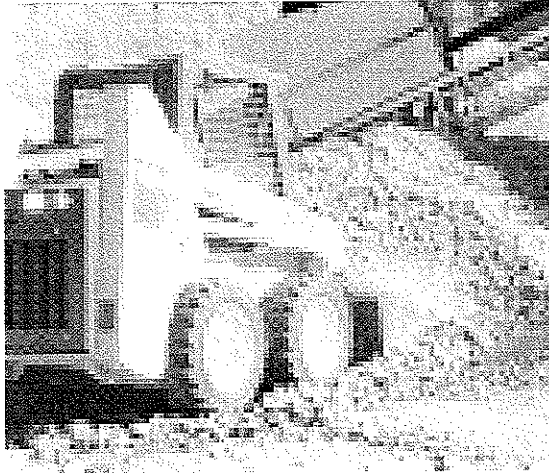

Less noise, more comfort... The E-Series really delivers versatility

Introducing the new Gehl E-Series Skid Loaders featuring performance and an expanded lineup of six models, ranging from the compact 3640E through the top-of-line 6640E, a real workhorse with exceptional hydraulic power. These machines are a "must-have" for every task, whether you're a contractor, landscaper, renter, farmer or just someone with a lot of work and not enough time.

All models offer spacious, ergonomically designed cabs with fatigue-fighting features for greater comfort and increased productivity. Plus, your choice of operator-friendly controls. Without a doubt, there's an E-Series Skid Loader to fit your needs with the performance you expect from Gehl.

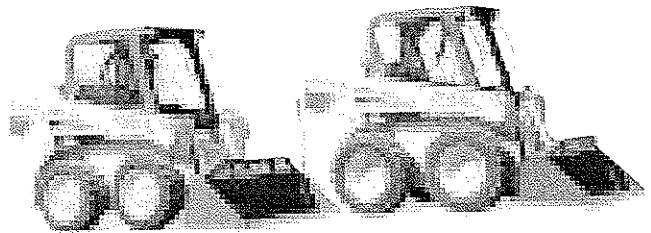

3640E / 4240E MODELS FEATURE:

Compact low-profile design for maneuverability in narrow, low-clearance areas

Powerful Yanmar diesel engines for power and performance where it counts

All-Tach™ attachment mounting system for compatibility with most attachments

4640E / 4840E / 5640E / 6640E MODELS FEATURE:

Innovative acoustical materials to reduce interior cab sound levels, and newly-designed engine-related components to lower sound levels, inside and out

New higher operating load ratings—up to 2900 lbs. with optional counterweights

Advanced high horsepower Deutz engines with in-cylinder glow plugs to improve cold weather starting and auto-shutdown systems

Exceptional hydraulic power for high breakout forces and outstanding attachment performance

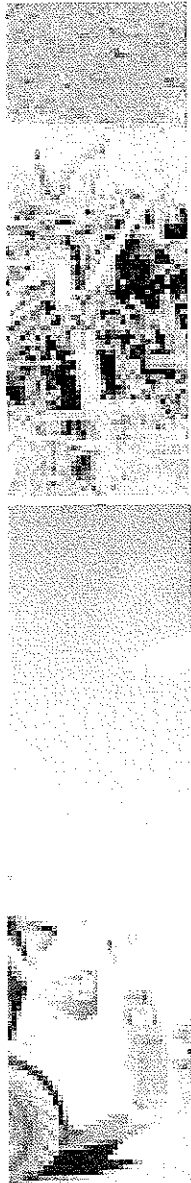

Right-sized machines will right-size every job

Gehl has become a big name in the skid loader business and it's not by chance. Gehl is constantly working to improve, enhance and increase performance, versatility, efficiency and operator comfort. The E-Series is the latest example of our commitment to give users the edge in productivity and profitability.

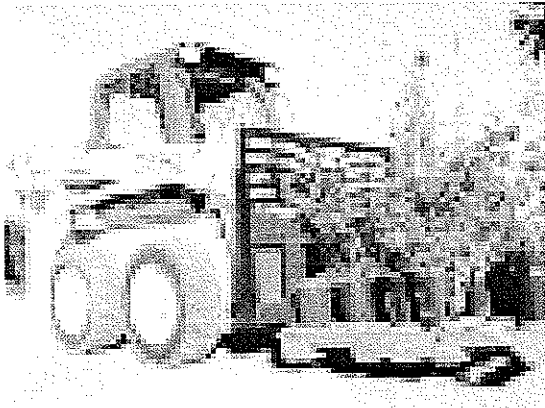

MODELS

3640E / 4240E

3640E / 4240E Features

Maneuverable in tight spaces. 48"/61" wide with ROPS/FOPS height of 70.3"/71.9" (3640E/4240E).

Improved drive controls require less effort and reduce operator fatigue.

More power—up to 46 hp, and higher operating load ratings—up to 1475 lbs. with optional counterweights (4240E).

Lighter weight for better performance, less tire wear and easier hauling (3640E).

Deluxe sound package option lowers sound levels in the operator's compartment.

Hydraulic self-leveling lift action optional.

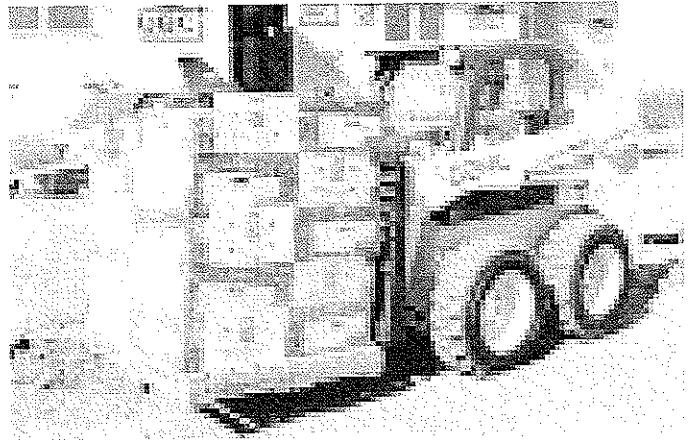

MODELS 4640E / 4840E / 5640E / 6640E

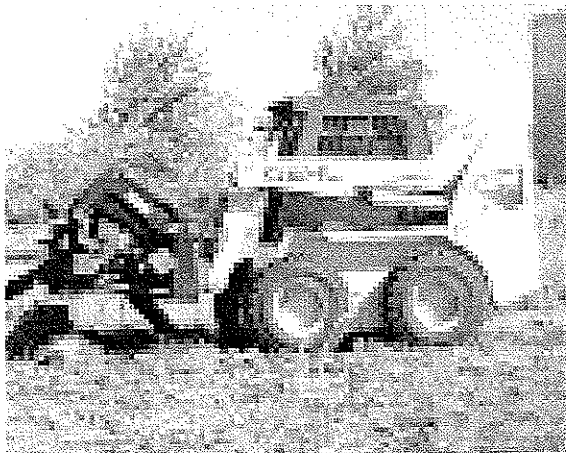
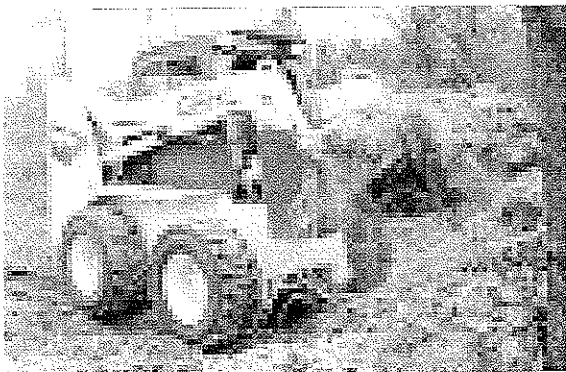

4640E / 4840E / 5640E / 6640E Features

Acoustical improvements reduce sound levels to among the lowest in the industry.

Compact muffler design lowers engine exhaust noise.

Increased operating load ratings up to 2600 lbs. (2900 lbs. with optional counterweights).

Standard and optional high-flow auxiliary hydraulic systems provide the high pressures and flows necessary to power virtually any attachment.

Maintenance-free, radial-piston drive motors have high start-up torque for rapid acceleration.

Standard ground speed up to 8.5 mph or up to 12.5 mph with optional two-speed drive.

Standard engine auto-shutdown feature turns off engine when low oil pressure or high temperatures are detected.

Standard heavy-duty high-flotation tires.

GEHL

Large cabs provide enhanced operator comfort

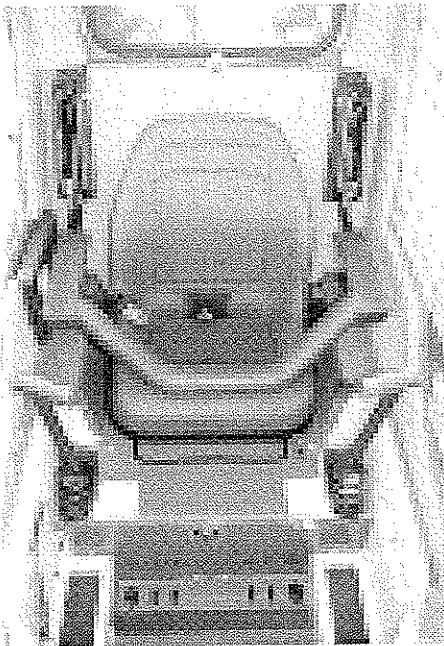

3640E / 4240E Interior with
T-Bar "Hands Only" Controls

A large operator compartment with clear side and rear sight lines provides operators full, expansive views for increased safety. High-back adjustable cushioned seat improves comfort. Suspension seat and factory-installed air-conditioning* and heater system are available options.

ROPS/FOPS (Level II) for extra operator protection.

Roof grid section and window provide excellent bucket visibility at full height.

Adjustable operator restraint bar offers secondary protection and serves as a padded armrest.

Interlock system locks out lift/tilt functions when optional front door is opened.

T-bar "hands-only," hand/foot or dual-hand* controls to match any operator's preference.

*Dual-hand control and air-conditioning not available on 3640E/4240E

Entire ROPS/FOPS structure pivots back, with gas-spring assist, for full, easy access to the internal hydraulic components.

Swing-open rear door and flip-up engine cover fully expose maintenance access points to engine, battery, filters and filler caps.

Maintenance-free axles are lubricated and sealed for long life.

Removable access plates for ease of clean out.

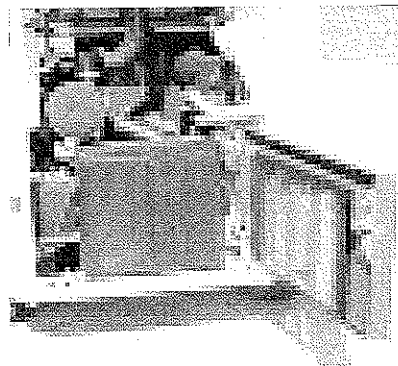

4640E
Interior

L O W M A I N T E N A N C E

DEHL

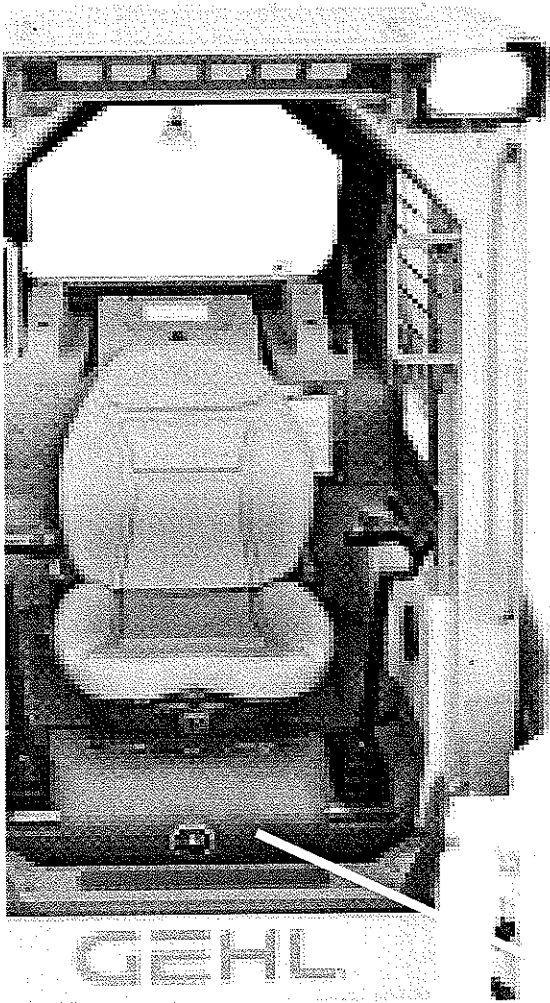

4640E / 4840E / 5640E / 6640E
with F-Bar "Hands-Only" Controls

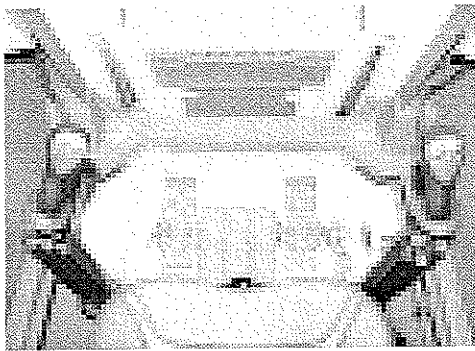

Hand/Foot Controls

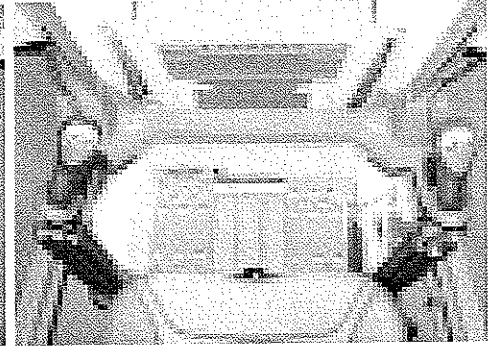

Dual-Hand Controls
(not available on 3640E/4240E)

One look and you'll see that the E-Series Skid Loaders are built for efficiency. The patented Powerview® lift arm offers excellent operator visibility. And Super Hi-power drive chains feature heavy, high-strength construction, designed to stand up to rugged conditions.

A layer of acoustical sound suppression material reduces operator noise levels in the cab.

S U P E R I O R P E R F O R M A N C E

Longer wheelbase and a low center of gravity offer a smooth, stable ride. Hydraglide™ ride control option is available on E-Series models 4640E/4840E/5640E/6640E.

Drivetrain on models 4640E/4840E/5640E/6640E features heavy-duty drive components. Adjustments can be made to the simple "bow tie" chain system from outside the unit.

Hydraloc™ automatic interlock system locks lift, tilt and drive systems when the operator leaves the seat, increasing operator safety. System also engages when the restraint bar is raised or the ignition switch is turned off.

Lift arm hydraulic tubes are concealed and protected from the work environment.

Forged one-piece axle shafts feature heavy-duty tapered roller bearings and "quad" lip seals with trash protection built-in around the seal area.

Rated operating load can be readily increased with the addition of counterweights.

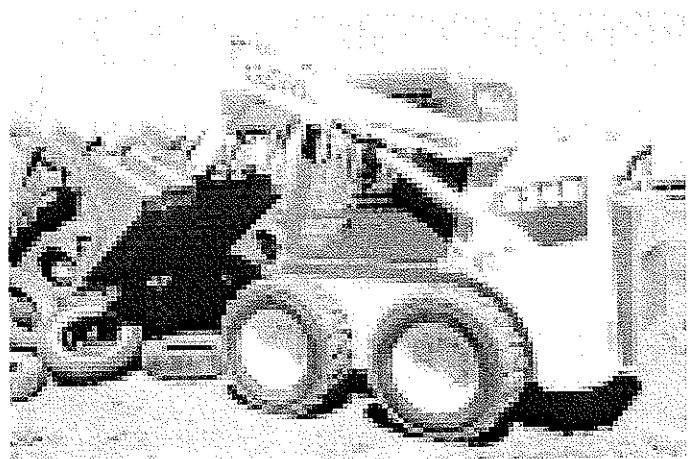

GEHL

The tools of the trades

FULL ATTACHMENT LINE
FOR ANY JOB

Your Gehl dealer is your best source for a full line of attachments and accessories designed specifically to fill your needs and to make your E-Series Skid Loader the most versatile machine on your job site.

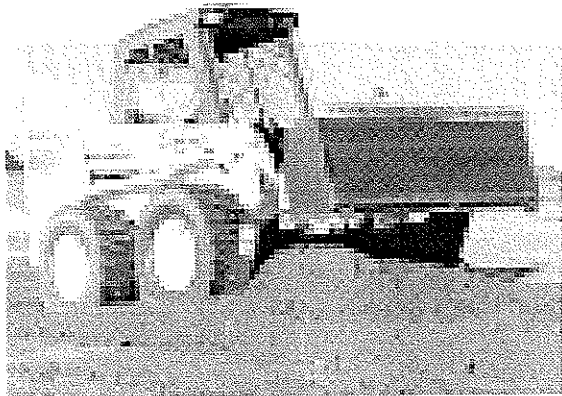
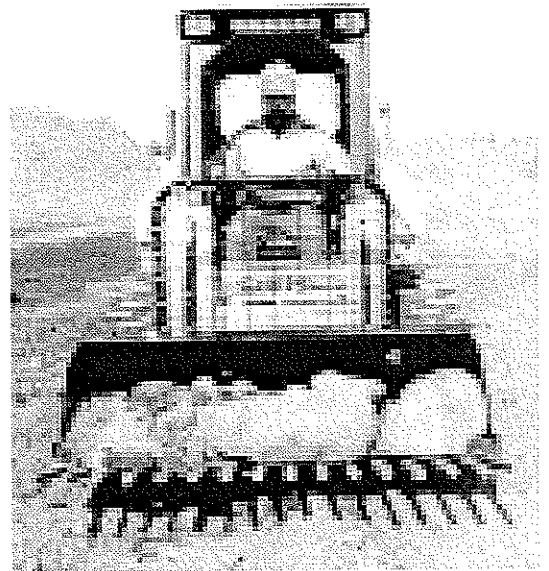
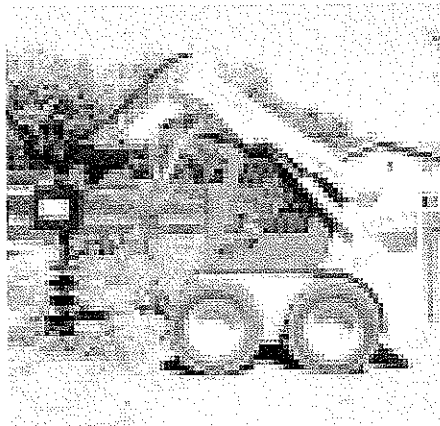

High horsepower and powerful hydraulic systems provide the pressure and flow to power virtually any attachment. Hydraulic self-leveling action keeps buckets, pallet forks and other attachments level during lifting actions (optional on 3640E/4240E).

GEHL



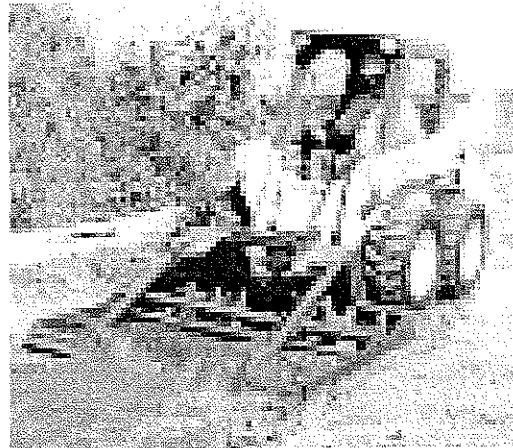
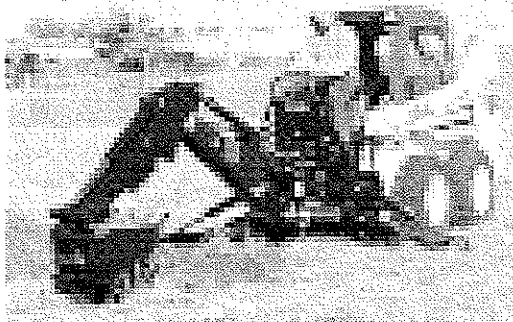
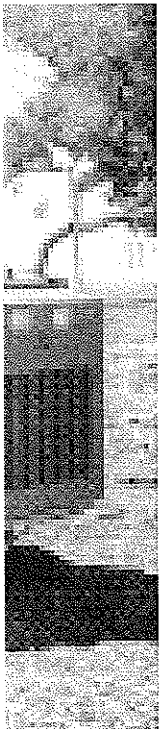
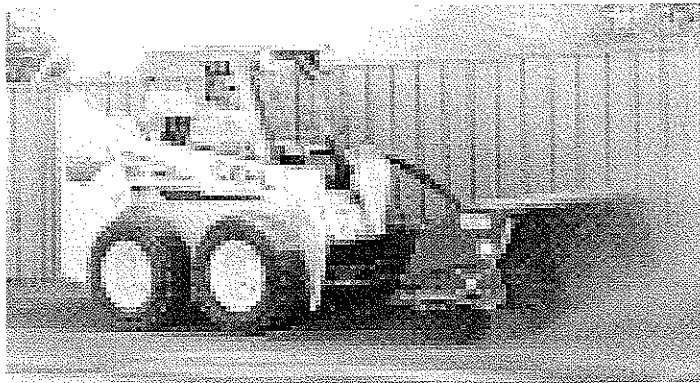
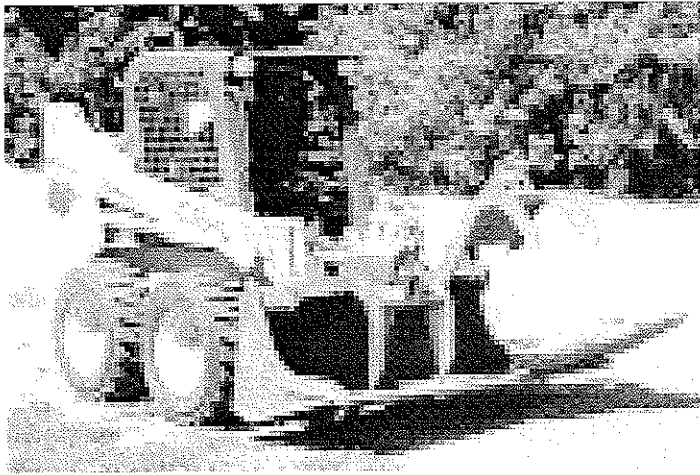

ATTACHMENT CHANGES ARE QUICK & EASY

All-Tach™

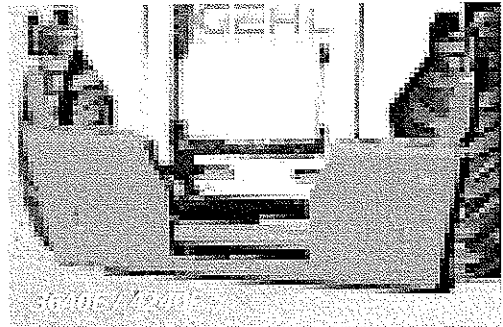

3640E / 4240E

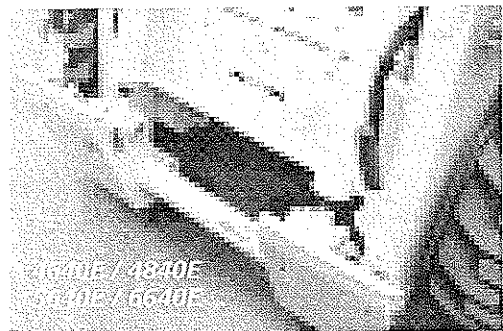

4640E / 4840E
5640E / 6640E

Power-A-Tach™

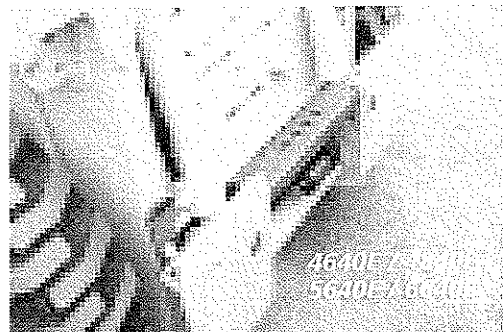

4640E / 5640E
5640E / 6640E

All models feature the easy-to-use All-Tach™ (universal-style) attachment mounting system compatible with most allied attachments.

Power-A-Tach™ system option* allows users to quickly add or remove attachments without leaving the seat.

*Power-A-Tach™ system option not available on 3640E/4240E

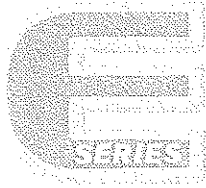

SPECIFICATIONS

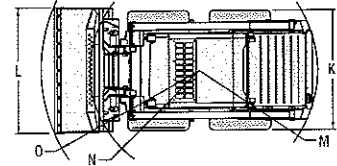
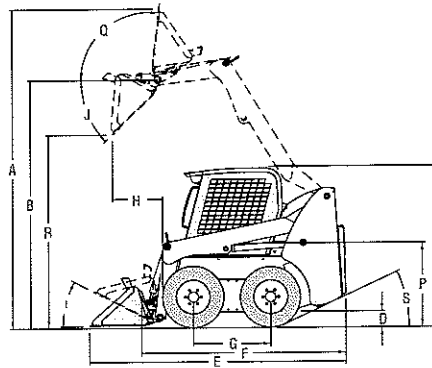

All dimensions are in inches (millimeters)
unless otherwise noted.

	3640E	4240E	4640E	4840E	5640E	6640E
A. Overall Operating Height (fully raised)	139.6 (3546)	141.1 (3584)	149 (3785)	149 (3785)	162 (4115)	168.3 (4274)
B. Height to Hinge Pin (fully raised)	108.1 (2746)	110 (2794)	115.5 (2934)	115.5 (2934)	123 (3124)	124.3 (3157)
C. Overall Height w/ ROPS/FOPS Cab	70.3 (1786)	71.9 (1826)	78.0 (1981)	78.0 (1981)	81.0 (2057)	82.0 (2082)
D. Ground Clearance	6 (152)	8.3 (211)	7.5 (191)	7.5 (191)	8.0 (203)	9.1 (231)
E. Overall Length	114 (2896) (w/55" bucket)	116.2 (2952) (w/61" bucket)	122.8 (3119) (w/66" bucket)	126.3 (3208) (w/66" bucket)	131.0 (3327) (w/70" bucket)	141.5 (3594) (w/74" bucket)
F. Overall Length (less bucket)	88.9 (2258)	91.1 (2314)	89.8 (2291)	93.3 (2370)	95.5 (2426)	101.0 (2565)
G. Wheelbase	34.5 (876)	36.7 (932)	37.5 (953)	41.5 (1054)	42.5 (1080)	48.4 (1219)
H. Dump Reach (at full height)	22.8 (579)	22.6 (574)	27.6 (701)	27.6 (701)	32.8 (833)	34.3 (863)
I. Rollback at Ground	29°	29°	27°	27°	30°	30°
J. Dump Angle	42°	42°	40°	40°	40°	40°
K. Overall Width	48.4 (1229)	52.5/58.4 (1334/1483)	63.5 (1613)	63.5 (1613)	67.0 (1702)	72.5 (1841)
L. Bucket Width	55.3 (1404)	60.6 (1539)	66 - 72 (1679 - 1829)	66 - 75 (1679 - 1905)	70 - 90 (1778 - 2286)	74 - 90 (1880 - 2286)
M. Clearance Circle (Rear)	54.1 (1374)	58.4 (1484)	59.5 (1513)	61.5 (1562)	66.0 (1679)	69.0 (1753)
N. Clearance Circle (Front, less bucket)	44.1 (1120)	43.4 (1102)	47 (1194)	48 (1219)	50.5 (1283)	54.0 (1372)
O. Clearance Circle (Front, w/bucket)	69.4 (1763)	69.2 (1758)	74.5 (1892)	76.0 (1930)	82.0 (2083)	90.5 (2299)
P. Seat to Ground Height	32.6 (828)	33.6 (853)	37.5 (953)	37.5 (953)	42.0 (1067)	43.3 (1100)
Q. Rollback at Full Height	99°	99°	86°	86°	84°	84°
R. Dump Height	84.5 (2146)	86.5 (2197)	89.5 (2273)	89.5 (2273)	93.5 (2375)	94.8 (2408)
S. Departure Angle	26°	29°	25°	25°	26°	29°
Standard Tire Size	27x8.5x15 HD	10.00x16.5 HD	10.00x16.5 HD	10.00x16.5 HD	12.00x16.5 HD	14.00x17.5 HD
ENGINE						
Make	Yanmar	Yanmar	Deutz ^(A)	Deutz	Deutz ^(B)	Deutz
Model	3TNV88	4TNV88	F3M2011 BF3M2011	F4M2011	F4M2011 BF4M2011	BF4M2011
Net Power (kW) @ RPM	35 hp (26) @ 2600	46 hp (34) @ 2600	46/60 hp (34/45) @ 2600	60 hp (45) @ 2500	60/82 hp (45/61) @ 2500	82 hp (61) @ 2500
Displacement (L)	100 cu. in. (1.64)	133 cu. in. (2.19)	142 cu. in. (2.3)	190 cu. in. (3.1)	190 cu. in. (3.1)	190 cu. in. (3.1)
HYDRAULIC SYSTEM						
T-bar Hand Controls, Hand/Foot Controls or Dual-Hand Controls ^(C)	Traction/ Lift/Tilt	Traction/ Lift/Tilt	Traction/ Lift/Tilt	Traction/ Lift/Tilt	Traction/ Lift/Tilt	Traction/ Lift/Tilt
Auxiliary Hyd. (L/min)	14.5 gpm (55)	16.5 gpm (62)	19 gpm (72)	19 gpm (72)	23 gpm (87.1)	23 gpm (87.1)
High-Flow Hyd.(L/min) – option	N/A	N/A	30 gpm (114)	30 gpm (114)	36 gpm (136.3)	36 gpm (136.3)
Filtration	4 micron	4 micron	3 micron	3 micron	3 micron	3 micron
Reservoir Capacity (L)	8 gal. (30.3)	8 gal. (30.3)	12 gal. (45)	12 gal. (45)	16 gal. (60)	16 gal. (60)

	3640E	4240E	4640E / 4640E Turbo	4840E	5640E / 5640E Turbo
ELECTRICAL SYSTEM					
Battery	12-volt (675 CCA)	12-volt (675 CCA)	12-volt (950 CCA)	12-volt (950 CCA)	12-volt (950 CCA)
Starter (kW)	12-volt (2.3)	12-volt (2.3)	12-volt (2.3)	12-volt (2.3)	12-volt (2.3)
Alternator	40-amp.	40-amp.	95-amp.	95-amp.	95-amp.
CAPACITIES / WEIGHTS					
Rated Operating Load (kg) ^(D)	1050 lbs. (476)	1350 lbs. (612)	1550 lbs. (680) / 1650 lbs. (748)	1900 lbs. (862)	2050 lbs. (930) / 2200 lbs. (998)
Rated Operating Load w/ Opt. Counterweight (kg) ^(D)	1175 lbs. (533)	1475 lbs. (669)	1700 lbs. (771) / 1800 lbs. (816)	2050 lbs. (930)	2350 lbs. (1066) / 2500 lbs. (1134)
Tipping Capacity (kg) ^(D)	2100 lbs. (952)	2700 lbs. (1225)	3100 lbs. (1361) / 3300 lbs. (1497)	3800 lbs. (1724)	4100 lbs. (1860) / 4400 lbs. (1996)
Fuel Tank (L)	10.3 gal. (38.9)	12.4 gal. (47)	15 gal. (56)	15 gal. (56)	19 gal. (72)
Travel Speed - max. (km/h)	6.8 mph (10.9)	6.4 mph (10.3)	8.1 mph (13) 11.4 mph (18.3) ^(E)	8.1 mph (13) 11.4 mph (18.3) ^(E)	8.4 mph (13.5) 12.5 mph (20) ^(E)
Operating Weight (kg) ^(F) - approx.	4000 lbs. (1814)	4600 lbs. (2087)	6200 lbs. (2812)	6480 lbs. (2939)	7380 lbs. (3347)
FEATURED EQUIPMENT					
Auxiliary Hydraulics	Yes	Yes	Yes	Yes	Yes
Brake Control (auto/manual)	Yes	Yes	Yes	Yes	Yes
Engine Heater	Opt.	Opt.	Opt.	Opt.	Opt.
Foot & Hand Throttles	Yes ^(G)	Yes ^(G)	Yes ^(G)	Yes ^(G)	Yes ^(G)
Anti-Vandalism Protection	Yes	Yes	Yes	Yes	Yes
Full Instrumentation	Yes	Yes	Yes	Yes	Yes
T-bar Hand Controls Available	Yes	Yes	Yes	Yes	Yes
Hand/Foot Controls Available	Yes	Yes	Yes	Yes	Yes
Dual-Hand Controls Available	No	No	Yes	Yes	Yes
Hourmeter	Yes	Yes	Yes	Yes	Yes
Hydraloc™ System	Yes	Yes	Yes	Yes	Yes
Hydrostatic Drive	Yes	Yes	Yes	Yes	Yes
Independent Hydraulic Reservoir	Yes	Yes	Yes	Yes	Yes
Integral Access Plate (removable)	Yes	Yes	Yes	Yes	Yes
Lift Arm Support Device	Yes	Yes	Yes	Yes	Yes
Operational Lights - frt & rear	Yes	Yes	Yes	Yes	Yes
Operator Restraint Bar with Padded Armrests/Seat Belt	Yes	Yes	Yes	Yes	Yes
Engine Auto-Shutdown System	Opt.	Opt.	Yes	Yes	Yes
All-Tach™ Attachment Mounting	Yes	Yes	Yes	Yes	Yes
ROPS/FOPS Level II Overhead Guard (w/integral side screens)	Yes	Yes	Yes	Yes	Yes
Self-Leveling Lift Action	Opt.	Opt.	Yes	Yes	Yes
Sound Reduction Package	Opt.	Opt.	Yes	Yes	Yes
Spark-Arrestor Muffler	Yes	Yes	Yes ^(H)	Yes	Yes ^(H)

(A) 4640E turbo versions use Deutz BF3M2011 Turbo engine – 60 hp.

(B) 5640E turbo versions use Deutz BF4M2011 Turbo engine – 82 hp.

(C) Dual-hand controls not available on 3640E/4240E.

(D) Per SAE J818, SAE J732, and ISO 14397.

(E) With 2-speed drive option.

(F) Weight of base unit with standard equipment, standard tires (heavy-duty flotation), standard (dirt/construction) bucket and 175 lb. (79 kg) operator.

(G) Foot throttle is standard with T-Bar and Dual-Hand controls, but not available with Hand/Foot controls.

(H) Naturally aspirated engines have spark-arrestor mufflers.

55405

12-volt
(950 CCA)
12-volt (2.3)
95-amp.

2600 lbs. (1179)

2900 lbs. (1315)

5200 lbs. (2359)

24 gal. (91)
8.4 mph (13.5)
12.5 mph (20)⁽¹⁾
7800 lbs. (3538)

Yes

Yes

Opt.

Yes⁽²⁾

Yes

Yes

Yes

Yes

Yes

Yes

Yes

Yes

Yes

Yes

Yes

Yes

Yes

Yes

Yes

Yes

Yes

Yes

No

SAFETY IS NO ACCIDENT.
Gehl Company reminds users to read and understand the operator's manual before operating any piece of equipment, and to be sure all safety devices and shields are securely in place and functioning properly.

Gehl Company reserves the right to make changes in specifications or add improvements at any time without notice or obligation.

GEHL

E-SERIES FEATURED OPTIONS



High-Flow Hydraulics



Enclosed Cab

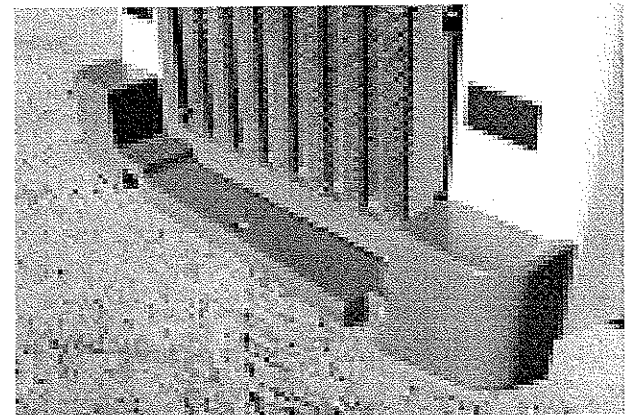

Counterweight Kit

GEHL

New E-Series Skid Loaders from Gehl!

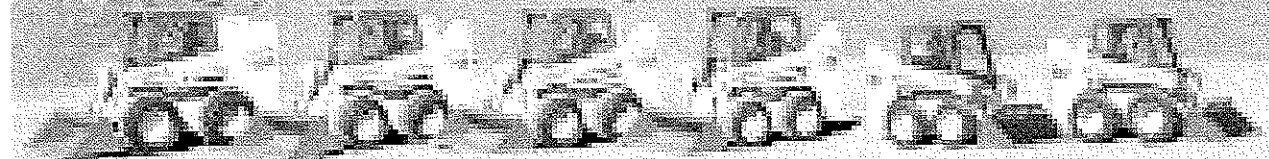

Select from six new models

Protect your investment with the Power Protection Plan[®] offered by Gehl

Eliminate unexpected repair costs and take better care of your Gehl equipment with the Power Protection Plan[®] offered by Gehl. It ensures repairs will be made quickly with genuine manufacturer-approved parts by trained mechanics. See your Gehl dealer for affordable coverage options.

Power Protection Plan[®]

GEHL

COMPACT EQUIPMENT FOR BIG RESULTS[™]

143 Water Street
West Bend, WI 53095
U.S.A.

Tel: 262-334-9461
Fax: 262-338-7517

SAVE BIG WITH GEHL FINANCE—Low rates...quick approval... terms you'll like... With Gehl Finance your equipment purchase couldn't be easier or more affordable. Choose from a number of flexible payment options. See your Gehl dealer for details.

PRE-DELIVERY-INSPECTION (PDI) ASSURES QUALITY IN ALL GEHL MACHINES—PDI certifies that the quality you expect will be the quality we deliver with every new skid loader that leaves our plant.

For more information on Gehl equipment, call our literature hotline at 800-628-0491 or visit our website: www.gehl.com